



Test Report

Product Name : CDMA Mobile Phone
Model No : Classic 501
FCC ID : UMPCA11001

Applicant : Inventec Appliances (Nanjing) Co., Ltd.

Address : No. 100 Xian He Street. Nanjing 210006. P.R.China

Date of Receipt : 2006/10/11

Issued Date : 2006/10/12

Report No. : 06AL075-HP-US-P10V01

The test results relate only to the samples tested.

The test report shall not be reproduced except in full without the written approval of Quietek Corporation.

This report must not be used to claim product endorsement by NVLAP any agency of the U.S. Government

Test Report Certification

Issued Date: 2006/10/12

Report No.:06AL075-HP-US-P10V01



Accredited by NIST (NVLAP)

NVLAP Lab Code: 200533-0

Product Name : CDMA Mobile Phone
Applicant : Inventec Appliances (Nanjing) Co., Ltd.
Address : No. 100 Xian He Street. Nanjing 210006. P.R.China
Manufacturer : Inventec Appliances (Nanjing) Co., Ltd.
Model No. : Classic 501
Rated Voltage : AC 120V/60Hz
Trade Name : Classic
Measurement Standard : FCC CFR Title 47 Part2 22
Measurement Reference : TIA/EIA 603-A
Test Result : Complied

Test results relate only to the samples tested.

The test report shall not be reproduced except in full without the written approval of Quietek Corporation.

This report must not be used to claim product endorsement by NVLAP any agency of the U.S. Government

Documented By :



(Eva Huang)

Tested By :



(Shine Hsu)

Approved By :



(George Chen)

TABLE OF CONTENTS

Description	Page
1. GENERAL INFORMATION	4
1.1. EUT Description	4
1.2. Operational Description.....	4
1.3. Configuration of tested System	4
1.4. EUT Setup Procedures	6
1.5. Test Facility	6
1.6. Type of Emission	7
1.7. DC voltages and DC currents	7
2. Peak Power Output	8
2.1. Test Equipment.....	8
2.2. Test Setup	8
2.3. Limits	9
2.4. Test Procedure.....	9
2.5. Test Specification	9
2.6. Test Result of Peak Power Output	10
3. Modulation Characteristics	12
3.1. Test Equipment.....	12
3.2. Test Setup	12
3.3. Modulation Description.....	12
3.4. Test Specification	13
3.5. Test Result of Modulation Characteristics	14
4. Occupied Bandwidth.....	15
4.1. Test Equipment.....	15
4.2. Test Setup	15
4.3. Test Procedure.....	15
4.4. Test Specification	16
4.5. Test Result of Occupied Bandwidth	17
5. Spurious Emission At Antenna Terminals (+/-1MHz)	19
5.1. Test Equipment.....	19
5.2. Setup	19
5.3. Limits	20
5.4. Test Procedure.....	20
5.5. Test Specification	20
5.6. Spurious Emission At Antenna Terminals (+/-1MHz)	21
6. Spurious Emission	22
6.1. Test Equipment.....	22
6.2. Test Setup	22
6.3. Limits	23
6.4. Test Procedure.....	23
6.5. Test Specification	23
6.6. Test Result of Spurious Emission	24
7. Frequency Stability Under Temperature & Voltage Variations	28
7.1. Test Equipment.....	28
7.2. Test Setup	28
7.3. Limits	28
7.4. Test Procedure.....	29
7.5. Test Specification	29
7.6. Test Result of Frequency Stability Under Temperature Variations	30
8. EMI Reduction Method During Compliance Testing	31
Attachment 1: EUT Test Photographs	
Attachment 2: EUT Detailed Photographs	

1. GENERAL INFORMATION

1.1. EUT Description

Product Name : CDMA Mobile Phone
 Trade Name : Classic
 Model No. : Classic 501
 TX Frequency : 824.73MHz ~ 848.19MHz(CDMA)
 RX Frequency : 869.73MHz ~ 893.19MHz(CDMA)
 FCC ID : UMPCA11001
 Antenna Type : Fixed
 Adapter : AC input: 100-240V 50/60Hz 90mA
 : DC output: 5VDC 400mA

1.2. Operational Description

The information contained within this report is intended to show verification of compliance of the CDMA 800MHz Mobile Phone to the requirements of 47CFR2 and CFR 22.

The EUT operates from a 120Vac/60Hz adapter where CDMA is Power Class 3, operating with a maximum output power range of 0.2W ~ 1W .
 QuieTek has verified the construction and function in typical operation. All the test modes were carried out with the EUT in normal operation, which was shown in this test report and defined as:

Test Mode:	CDMA2000 (800MHz)
------------	-------------------

1.3. Configuration of tested System

(a) Configuration of Radiated measurement

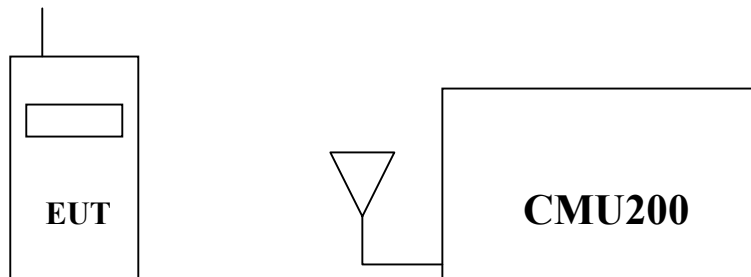

(b) Configuration of Conducted measurement

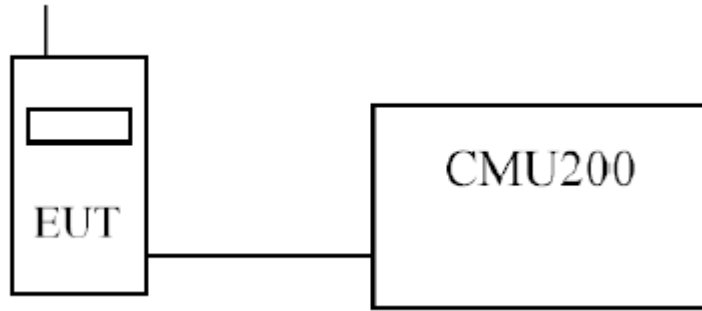

1.4. EUT Setup Procedures

- (1) Setup the EUT and simulators as shown on 1.3
- (2) Turn on the power of all equipments.
- (3) The EUT was set to communicate with CMU200.
- (4) Repeat the above procedure (3).

1.5. Test Facility

Ambient conditions in the laboratory:

Items	Required (IEC 68-1)	Actual
Temperature (°C)	15-35	20-35
Humidity (%RH)	25-75	50-65
Barometric pressure (mbar)	860-1060	950-1000

Site Description: June 22, 2001 File on
 Federal Communications Commission
 FCC Engineering Laboratory
 7435 Oakland Mills Road
 Columbia, MD 21046
 Reference 31040/SIT1300F2

July 03, 2001 Accreditation on NVLAP
 NVLAP Lab Code: 200533-0

Site Name: Quietek Corporation

Site Address: No. 5-22, Ruei-Shu Valley, Ruei-Ping Tsuen,
 Lin-Kou Shiang, Taipei,
 Taiwan, R.O.C.
 TEL: 886-2-8601-3788 / FAX : 886-2-8601-3789
 E-Mail : service@quietek.com

1.6. Type of Emission

1M25F9W

1.7. DC voltages and DC currents

EUT Transmitting (in maximum power) :

DC voltage : 3.7V , DC current : 0.40A

EUT Standby :

DC voltage : 3.7V , DC current : 0.21A

2. Peak Power Output

2.1. Test Equipment

The following test equipments are used during the radiated emission test:

Test Site	Equipment	Manufacturer	Model No./Serial No.	Last Cal.
☒OATS 3	Test Receiver	R & S	ESCS 30 / 100122	Feb., 2006
	Universal Radio Communication Tester	R & S	CMU200 / 104846	May, 2006
	Spectrum Analyzer	Advantest	R3162 / 120300652	Feb., 2006
	Pre-Amplifier	QTK	QTK-AMP-03 / 0003	May, 2006
	Bilog Antenna	SCHAFFNER	CBL6112B / 2697	May, 2006
	Horn Antenna	ETS	3115 / 0005-6160	Jul., 2006
	Pre-Amplifier	QTK	QTK-AMP-01 / 0001	Jul., 2006

Note: 1. All equipments that need to be calibrated are with calibration period of 1 year.
 2. Mark "X" test instruments are used to measure the final test results.

2.2. Test Setup

Radiated Power Measurement

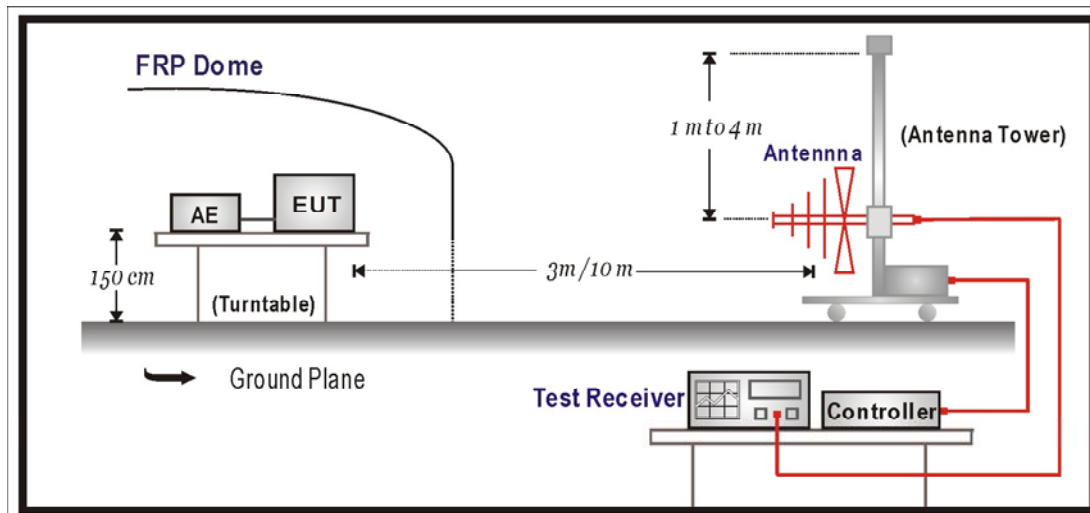

Conducted Power Measurement

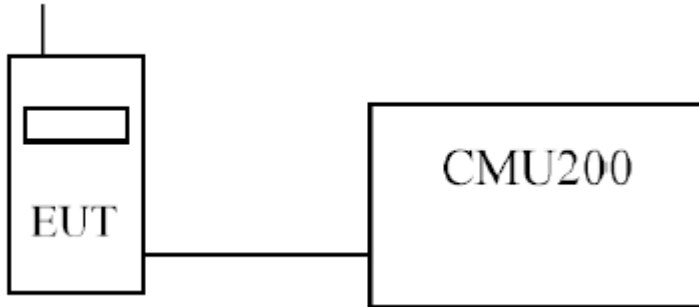

2.3. Limits

Limit	<7W
--------------	---------------

2.4. Test Procedure

➤RF Out Power (Radiated)

The Spectrum Analyzer was tuned to the test frequency. The device was put into Transmit mode then rotated through 360 degrees until the highest power level was observed in both horizontal and vertical polarization. The device was then replaced with a substitution antenna, which input signal was adjusted until the received level matched that of the previously detected emission.

➤RF Out Power (Conducted)

Using a spectrum analyser and attenuator(s), the output power of the EUT was measured at the antenna terminals. The EUT support CDMA 800MHz. The device is a class 3 module. The carrier was modulated by it's normal QPSK modulation and measurements performed with CDMA maximun power..

The spectrum analyser RBW and VBW were set to 1MHz and the path loss measured and entered as a reference level offset.

2.5. Test Specification

According to Part 2.1046, 22.913.

2.6. Test Result of Peak Power Output

Product	CDMA Mobile Phone		
Test Mode	RF Output Power (Conducted)		
Date of Test	2006/10/5	Test Site	CB4
Test Condition	CDMA2000 (800Mhz)		

Maximum Power-CDMA (800MHz)

Frequency (MHz)	Output Power (dBm)	Path Loss (dB)	Result (dBm)	Result (W)
824.73	23.56	0.5	24.06	0.255
836.40	23.37	0.5	23.87	0.244
848.19	23.78	0.5	24.28	0.268

Note:

1. EUT complies with CFR 47.2.1046 and 22.913(a). The EUT does not exceed 7W at the measured frequencies.

Product	CDMA Mobile Phone		
Test Mode	RF Output Power (Radiated)		
Date of Test	2006/10/05	Test Site	CB4
Test Condition	CDMA2000 (800Mhz)		

Maximum Power-CDMA (800MHz)

Frequency (MHz)	Raw Result (dBm)	Substitution Level (dBm)	Substitution Antenna Gain (dBd)	Cable Loss (dB)	Result ERP (dBm)	Result ERP (W)
824.73	15.30	17.36	4.45	0.49	21.32	0.136
836.40	14.66	16.51	4.45	0.49	20.47	0.111
848.19	15.68	17.69	4.45	0.49	21.65	0.146

Note:

1. The EUT meets the requirements of FCC CFR 47: Part 22, Section 22.913(a) for Effective Radiated Power.

3. Modulation Characteristics

3.1. Test Equipment

The following test equipment are used during the modulation characteristics test:

Equipment	Manufacturer	Model No./Serial No.	Last Cal.
Spectrum Analyzer	Advantest	R3182 / 100803470	May, 2006
Universal Radio Communication Tester	R & S	CMU200 / 104846	May, 2006
Directional couple	Agilent	87300C/3239A01864	N/A
Directional coupler	Agilent	778D-012/50550	N/A

Note: All equipments that need to be calibrated are with calibration period of 1 year.

3.2. Test Setup

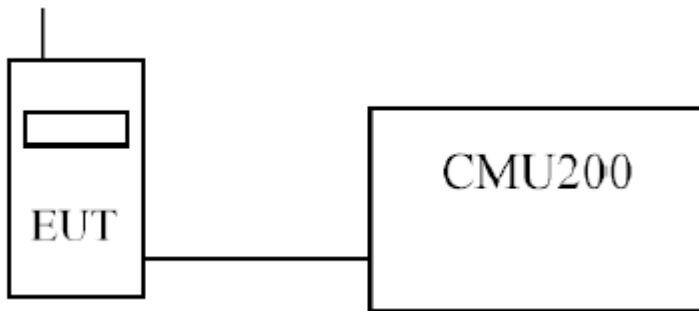

3.3. Modulation Description

Cdma2000 is the 3GPP2 standard for 3G technology derived from cdmaOne.

cdma2000 uses QPSK modulation for the forward link and QPSK modulation with HPSK spreading for the reverse link. In quadriphase-shift keying (QPSK), as with binary PSK, information carried by the transmitted signal is contained in the phase. The phase of the carrier takes on one of four equally spaced values, such as 45°, 135°, 225°, -45°.

Cdma 2000 systems use Hybrid Phase Shift Keying (HPSK), also known as Orthogonal Complex Quadrature Phase Shift Keying (OCQPSK), to reduce the peak-to-average power ratio of the signal. HPSK is a variation of basic complex scrambling that eliminates zero-crossings for every second chip point. It accomplishes this by using a specific repeating sequence (or function) as the scrambling signal and by choosing specific orthogonal codes to spread the different channels.

HPSK uses complex scrambling with a fixed repeating function as the scrambling signal.

This function is known as the Walsh rotator

3.4. Test Specification

According to Part 2.1047(d)

3.5. Test Result of Modulation Characteristics

Product	CDMA Mobile Phone		
Test Mode	Modulation Characteristics		
Date of Test	2006/10/05	Test Site	CB4
Test Condition	CDMA2000 (800MHz)		

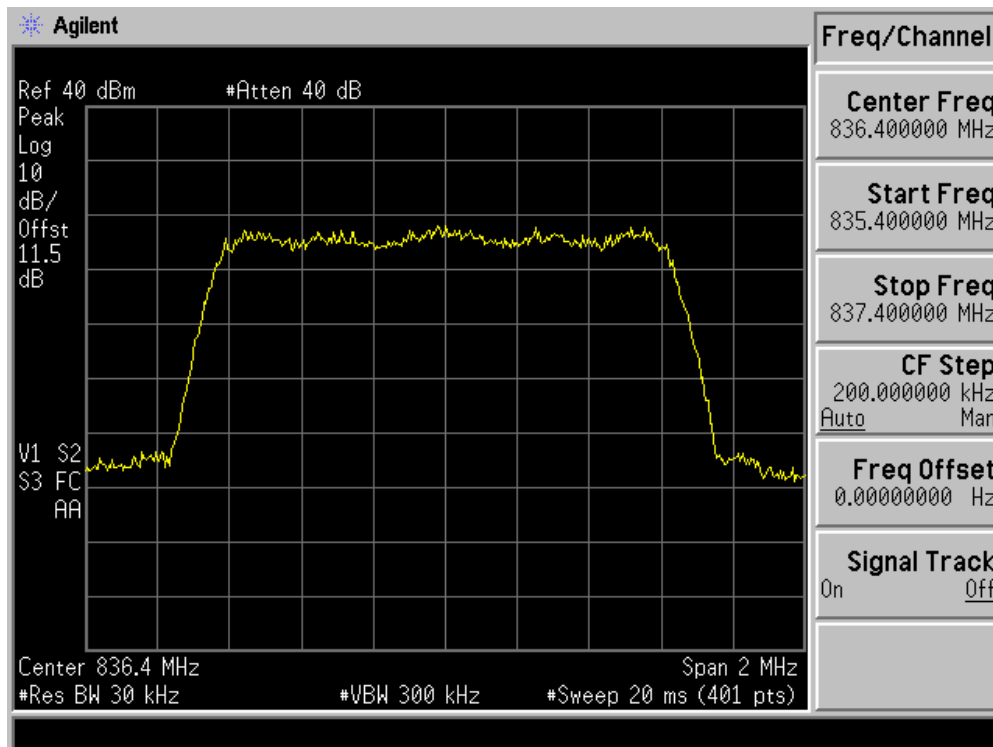

4. Occupied Bandwidth

4.1. Test Equipment

The following test equipments are used during the occupied bandwidth tests:

Equipment	Manufacturer	Model No./Serial No.	Last Cal.
Spectrum Analyzer	Advantest	R3182 / 100803470	May, 2006
Universal Radio Communication Tester	R & S	CMU200 / 104846	May, 2006
Directional coupler	Agilent	87300C/3239A01864	N/A
Directional coupler	Agilent	778D-012/50550	N/A

Note: All equipments upon which need to be calibrated are with calibration period of 1 year.

4.2. Test Setup

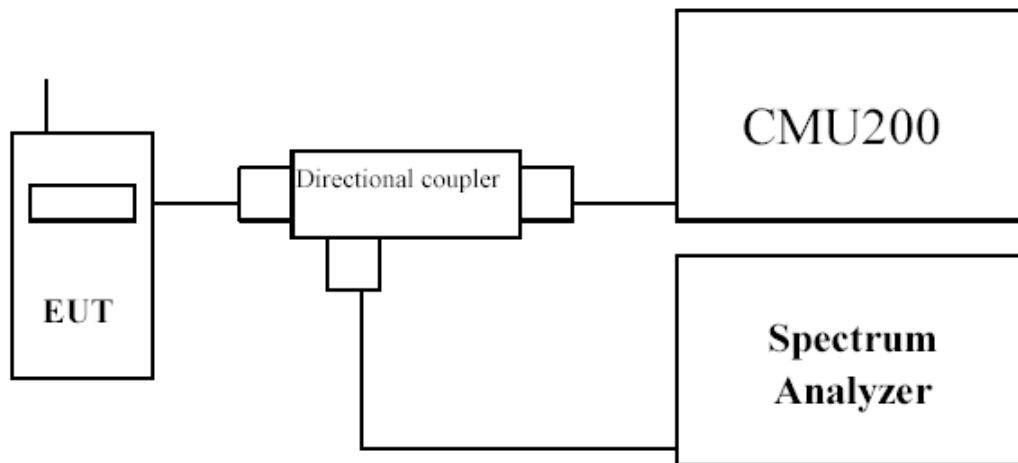

4.3. Test Procedure

➤CDMA2000

The EUT was set to transmit on maximum power, using a resolution bandwidth of 30kHz and a video bandwidth of 100kHz, the -26dBc points were established and the emission bandwidth determined.

The plots below show the resultant display from the Spectrum Analyzer.

4.4. Test Specification

According to Part 2.1049, 22.917(b).

4.5. Test Result of Occupied Bandwidth

Product	CDMA Mobile Phone		
Test Mode	Occupied Bandwidth		
Date of Test	2006/10/05	Test Site	CB4
Test Condition	CDMA2000 (800MHz)		

Channel1014

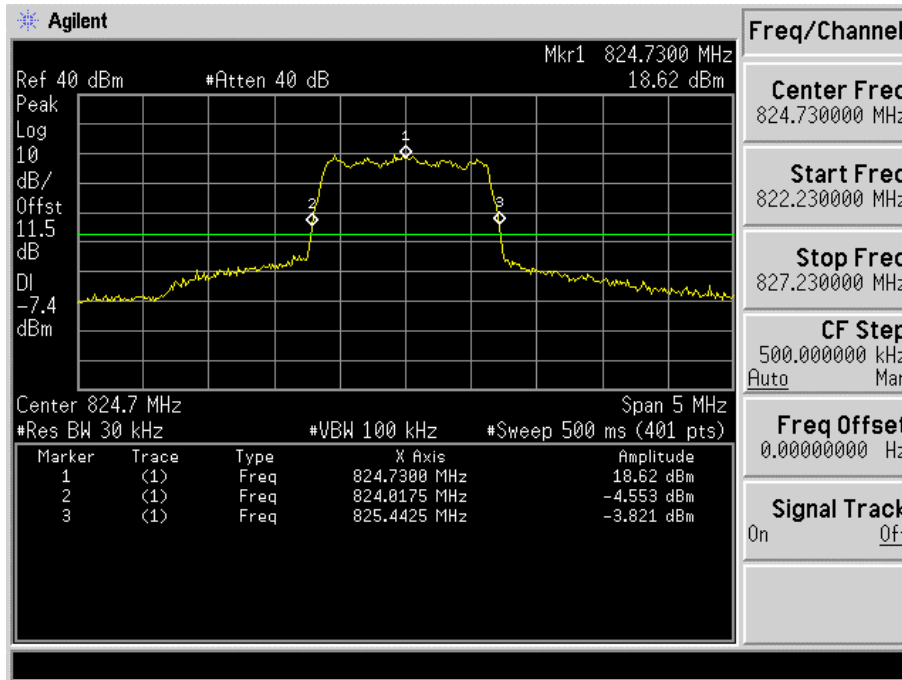

Channel 380

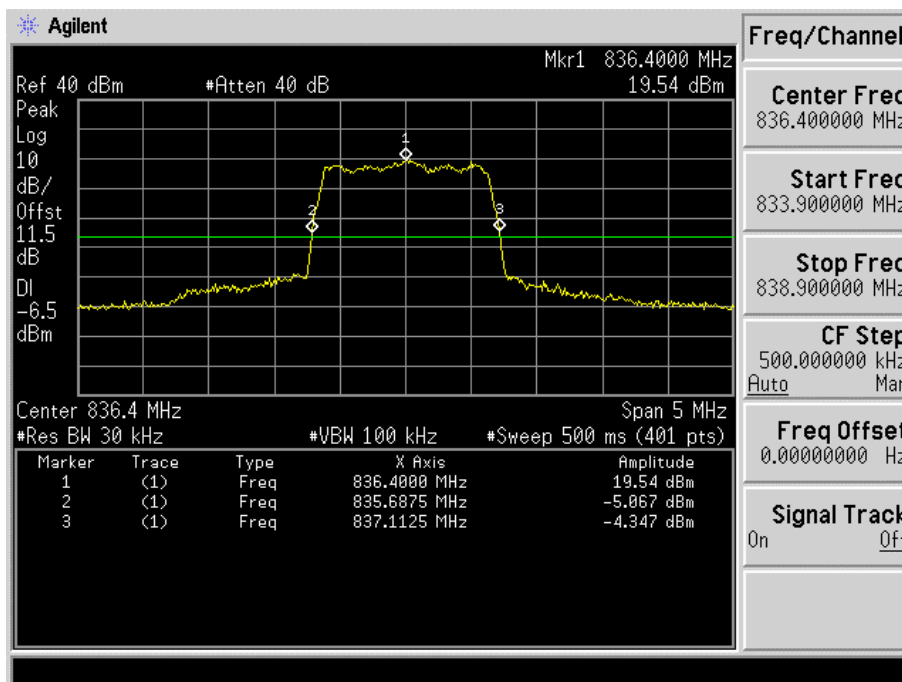

Product	CDMA Mobile Phone		
Test Mode	Occupied Bandwidth		
Date of Test	2006/10/05	Test Site	CB4
Test Condition	CDMA2000 (800MHz)		

Channel773

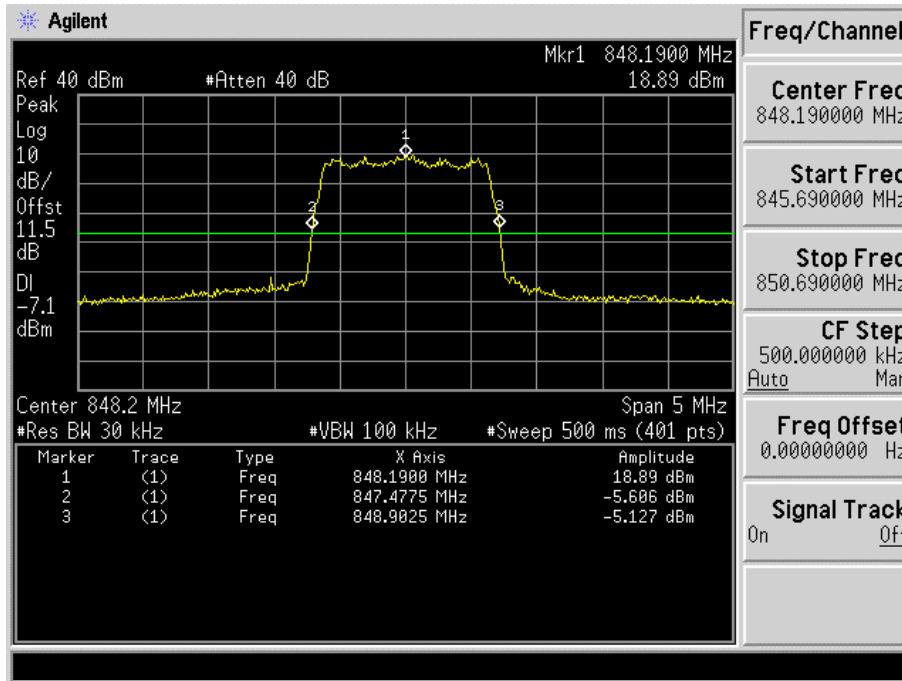

5. Spurious Emission At Antenna Terminals (+/-1MHz)

5.1. Test Equipment

The following test equipments are used during the spurious emission test

Equipment	Manufacturer	Model No./Serial No.	Last Cal.
Spectrum Analyzer	Advantest	R3182 / 100803470	May, 2006
Universal Radio Communication Tester	R & S	CMU200 / 104846	May, 2006
Directional coupler	Agilent	87300C/3239A01864	N/A
Directional coupler	Agilent	778D-012/50550	N/A

Note: All equipments upon which need to be calibrated are with calibration period of 1 year.

5.2. Setup

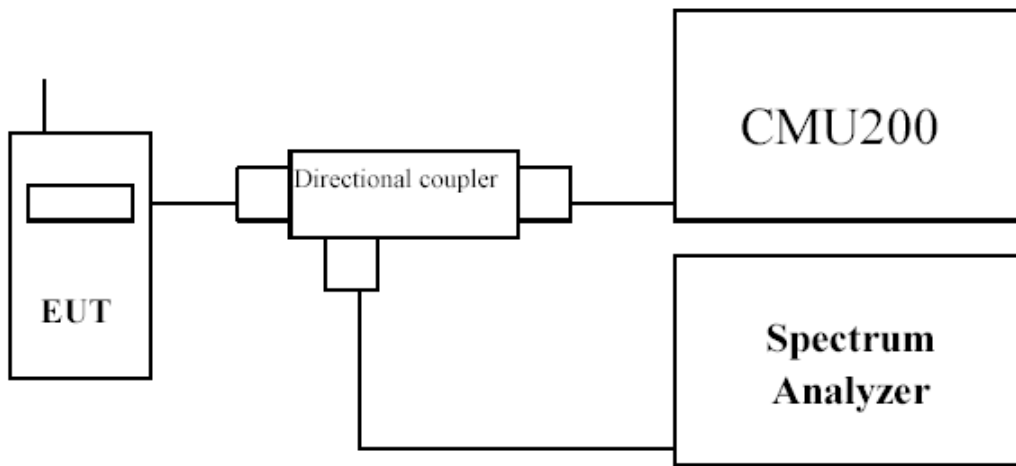

5.3. Limits

Transmitter limits for narrowband spurious emission

Lower Block Edge Test Frequencies	Upper Block Edge Test Frequencies
Block A Frequency : 824 MHz	Block B Frequency : 849 MHz

5.4. Test Procedure

In accordance with Part 22.917, at least 1% of the emission bandwidth was used for the resolution and video bandwidths up to 1MHz away from the Block Edge. At greater than 1MHz, the resolution and video bandwidth were increased to 1MHz.

The reference power and path losses of all channels used for testing in each frequency block were measured.

5.5. Test Specification

According to Part 2.1049, 22.917.

5.6. Spurious Emission At Antenna Terminals (+/-1MHz)

Product	CDMA Mobile Phone		
Test Mode	Spurious Emission At Antenna Terminals (+/-1MHz)		
Date of Test	2006/10/05	Test Site	CB4
Test Condition	CDMA2000 (800MHz), Block Edge Test		

CDMA Lower Frequency (824MHz)

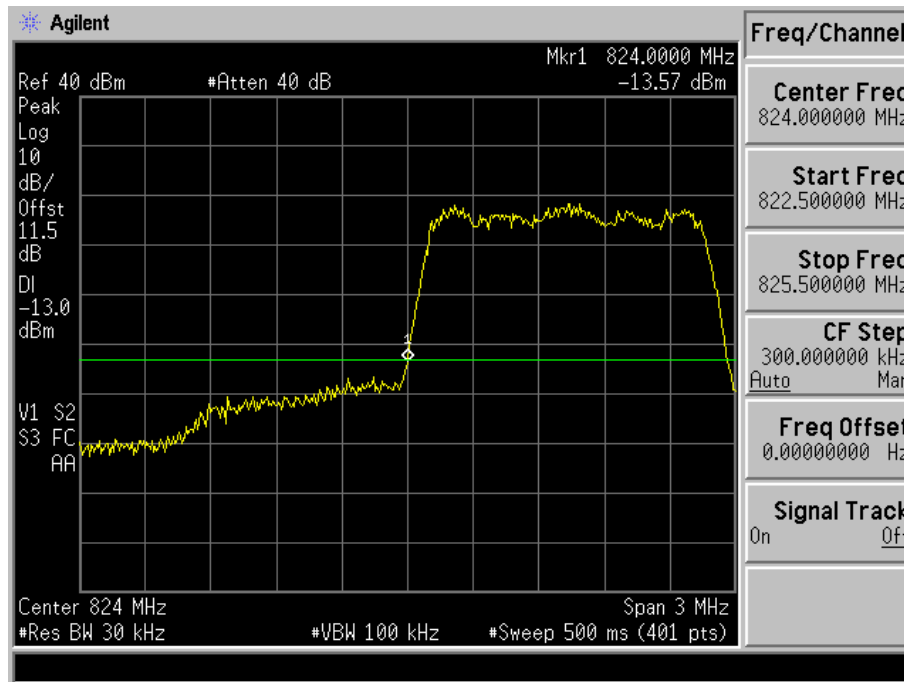

CDMA Upper Frequency (849MHz)

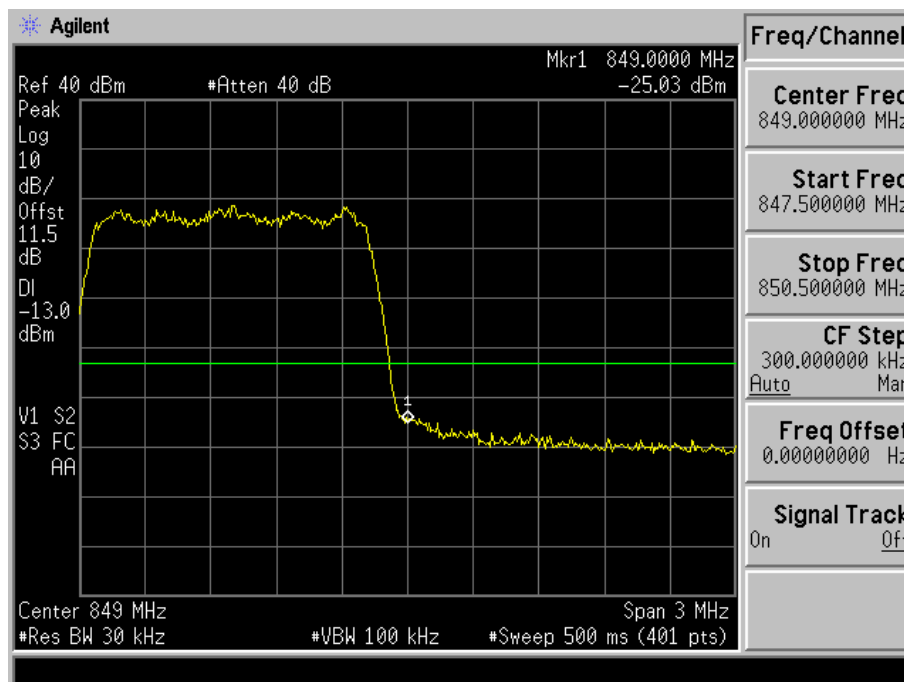

6. Spurious Emission

6.1. Test Equipment

The following test equipments are used during the radiated emission test:

Test Site	Equipment	Manufacturer	Model No./Serial No.	Last Cal.
☒OATS 3	Test Receiver	R & S	ESCS 30 / 100122	Feb., 2006
	Universal Radio Communication Tester	R & S	CMU200 / 104846	May, 2006
	Spectrum Analyzer	Advantest	R3162 / 120300652	Feb., 2006
	Pre-Amplifier	QTK	QTK-AMP-03 / 0003	May, 2006
	Bilog Antenna	SCHAFFNER	CBL6112B / 2697	May, 2006
	Horn Antenna	ETS	3115 / 0005-6160	Jul., 2006
	Pre-Amplifier	QTK	QTK-AMP-01 / 0001	Jul., 2006

- Note: 1. All equipments that need to be calibrated are with calibration period of 1 year.
 2. Mark "X" test instruments are used to measure the final test results.

6.2. Test Setup

(b) Field strength of spurious radiation.

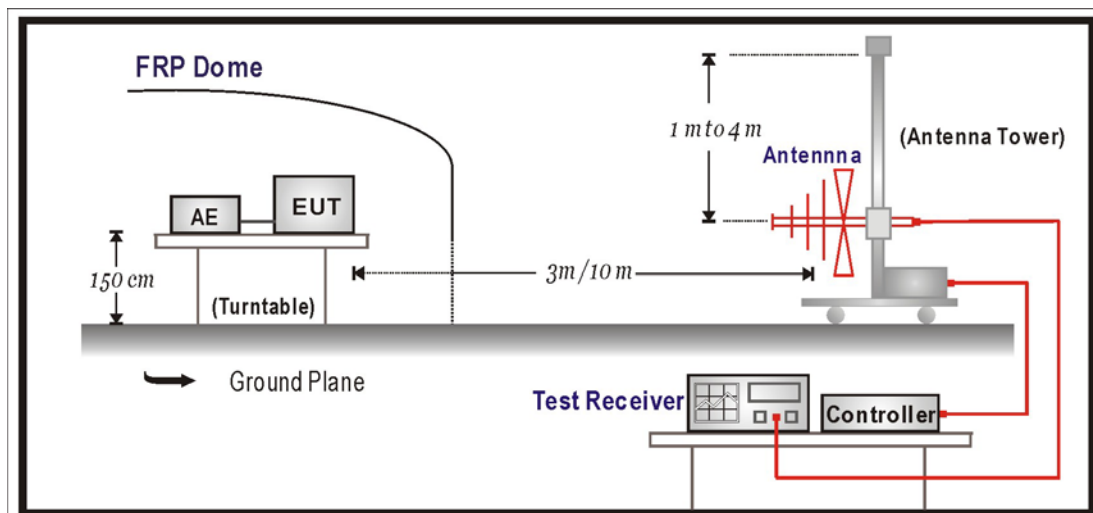

6.3. Limits

Limit	<-13dBm
--------------	-------------------

43 + 10Log(P) down on the carrier where P is the power in Watts.

6.4. Test Procedure

In accordance with Part 2.1051, the spurious emissions from the antenna terminal were measured. The transmitter output power was attenuated using a combination of filters and attenuators and the frequency spectrum investigated from 9kHz to 10GHz. The EUT was set to transmit on full power. The EUT was tested on bottom, middle and top channels for both power levels. The resolution and video bandwidth was set to 1MHz in accordance with Part 22.917. The spectrum analyzer detector was set to Max Hold.

In addition, measurements were made up to the 10th harmonic of the fundamental.

The EUT is placed on a turn table which is 1.5 meter above ground. The turn table can rotate 360 degrees to determine the position of the maximum emission level. The EUT was positioned such that the distance from antenna to the EUT was 3 meters.

The antenna can move up and down between 1 meter and 4 meters to find out the maximum emission level.

Both horizontal and vertical polarization of the antenna are set on measurement. In order to find the maximum emission, all of the interface cables must be manipulated according to TIA/EIA 603-A on radiated measurement.

6.5. Test Specification

According to Part 2.1051, 2.1053, 22.917(a).

6.6. Test Result of Spurious Emission

Product	CDMA Mobile Phone		
Test Mode	Spurious Emission (Conducted)		
Date of Test	2006/10/05	Test Site	CB4
Test Condition	CDMA2000 (800MHz)	Test Range	9KHz~10GHz

CDMA-Channel 1014

Frequency (GHz)	Reading Level (dBm)	Path Loss (dB)	Emission Level (dBm)	Limit (dBm)
1.65	-35.92	0.35	-35.57	-13
2.47	-41.68	0.42	-41.26	-13
4.95	-58.71	0.63	-58.08	-13
7.42	-56.21	1.02	-55.19	-13

CDMA-Channel 380

Frequency (GHz)	Reading Level (dBm)	Path Loss (dB)	Emission Level (dBm)	Limit (dBm)
1.67	-38.62	0.35	-38.27	-13
2.51	-32.4	0.42	-31.98	-13
5.02	-57.84	0.63	-57.21	-13
7.52	-57.08	1.02	-56.06	-13

CDMA-Channel 773

Frequency (GHz)	Reading Level (dBm)	Path Loss (dB)	Emission Level (dBm)	Limit (dBm)
1.70	-37.68	0.35	-37.33	-13
2.54	-37.07	0.42	-36.65	-13
5.09	-58.46	0.63	-57.83	-13
7.63	-57.23	1.02	-56.21	-13

Note:

- Receiver setting (Peak Detector) : RBW:1MHz; VBW:3MHz

Product	CDMA Mobile Phone		
Test Mode	Spurious Emission (Radiated)		
Date of Test	2006/10/05	Test Site	No.3 OATS
Test Condition	CDMA2000 (800MHz), Channel 1014	Test Range	9KHz ~10GHz

Frequency	Reading Level	Signal Generator Level	Cable Loss	Antenna Gain	ERP Value	Limit
(GHz)	(dBm)	(dBm)	(dB)	(dBd)	(dBm)	(dBm)

Horizontal Emissions

1.65	-41.97	-47.84	0.99	7.75	-41.08	-13
2.47	-43.07	-48.61	1.20	8.45	-41.36	-13
3.30	-44.24	-49.36	1.38	9.95	-40.79	-13
4.12	-54.60	-56.01	1.51	10.45	-47.07	-13
7.42	-60.33	N/A	2.01	9.35	< -50	-13

Vertical Emissions

1.65	-46.64	-51.18	0.99	7.75	-44.42	-13
2.47	-50.92	-56.46	1.20	8.45	-49.21	-13
3.30	-52.15	-57.16	1.38	9.95	-48.59	-13
4.12	-54.86	-58.47	1.51	10.45	-49.53	-13
7.42	-60.12	N/A	2.01	9.35	< -50	-13

Note:

1. Spurious emissions past 8GHz are not shown, due to the magnitude of spurious emissions attenuated more than 20 dB below the limit
2. Receiver setting (Peak Detector) : RBW:1MHz; VBW:3MHz.
3. ERP Value = Signal Generator Level + Antenna Gain - Cable Loss

Product	CDMA Mobile Phone		
Test Mode	Spurious Emission (Radiated)		
Date of Test	2006/10/05	Test Site	No.3 OATS
Test Condition	CDMA2000 (800MHz), Channel 380	Test Range	9KHz ~10GHz

Frequency	Reading Level	Signal Generator Level	Cable Loss	Antenna Gain	ERP Value	Limit
(GHz)	(dBm)	(dBm)	(dB)	(dBd)	(dBm)	(dBm)

Horizontal Emissions

1.67	-42.42	-48.82	0.99	7.75	-42.06	-13
2.51	-45.75	-50.25	1.20	8.45	-43.00	-13
3.35	-47.48	-53.03	1.38	9.95	-44.46	-13
4.18	-52.43	-54.97	1.51	10.45	-46.03	-13
7.52	-60.73	N/A	2.01	9.35	< -50	-13

Vertical Emissions

1.67	-46.56	-52.91	0.99	7.75	-46.15	-13
2.51	-51.60	-56.65	1.20	8.45	-49.40	-13
3.35	-53.90	-58.44	1.38	9.95	-49.87	-13
4.18	-54.43	-58.62	1.51	10.45	-49.68	-13
7.52	-60.44	N/A	2.01	9.35	< -50	-13

Note:

1. Spurious emissions past 8GHz are not shown, due to the magnitude of spurious emissions attenuated more than 20 dB below the limit
2. Receiver setting (Peak Detector) : RBW:1MHz; VBW:3MHz ◦
3. ERP Value = Signal Generator Level + Antenna Gain - Cable Loss

Product	CDMA Mobile Phone		
Test Mode	Spurious Emission (Radiated)		
Date of Test	2006/10/5	Test Site	No.3 OATS
Test Condition	CDMA2000 (800MHz), Channel 773	Test Range	9KHz ~10GHz

Frequency	Reading Level	Signal Generator Level	Cable Loss	Antenna Gain	ERP Value	Limit
(GHz)	(dBm)	(dBm)	(dB)	(dBd)	(dBm)	(dBm)

Horizontal Emissions

1.70	-43.72	-49.24	0.99	7.75	-42.48	-13
2.54	-46.54	-49.74	1.20	8.45	-41.99	-13
3.40	-48.63	-52.52	1.38	9.95	-43.95	-13
4.25	-55.21	-56.46	1.51	10.45	-47.52	-13
7.63	-60.81	N/A	2.01	9.35	< -50	-13

Vertical Emissions

1.70	-48.17	-53.56	0.99	7.75	-46.80	-13
2.54	-52.92	-57.01	1.20	8.45	-49.76	-13
3.40	-54.28	-57.79	1.38	9.95	-49.22	-13
4.25	-55.39	-58.86	1.51	10.45	-49.92	-13
7.63	-60.74	N/A	2.01	9.35	< -50	-13

Note:

1. Spurious emissions past 8GHz are not shown, due to the magnitude of spurious emissions attenuated more than 20 dB below the limit
2. Receiver setting (Peak Detector) : RBW:1MHz; VBW:3MHz ◦
3. ERP Value = Signal Generator Level + Antenna Gain - Cable Loss

7. Frequency Stability Under Temperature & Voltage Variations

7.1. Test Equipment

The following test equipments are used during the frequency stability test:

Equipment	Manufacturer	Model No./Serial No.	Last Cal.
Universal Radio Communication Tester	R & S	CMU200 / 104846	May, 2006
Standard Temperature & Humidity Chamber	WIT	TH-1S-B / 108210	Aug., 2006
DC Power Supply	Topward	6303D / 670302	N/A

Note: All equipments upon which need to be calibrated are with calibration period of 1 year

7.2. Test Setup

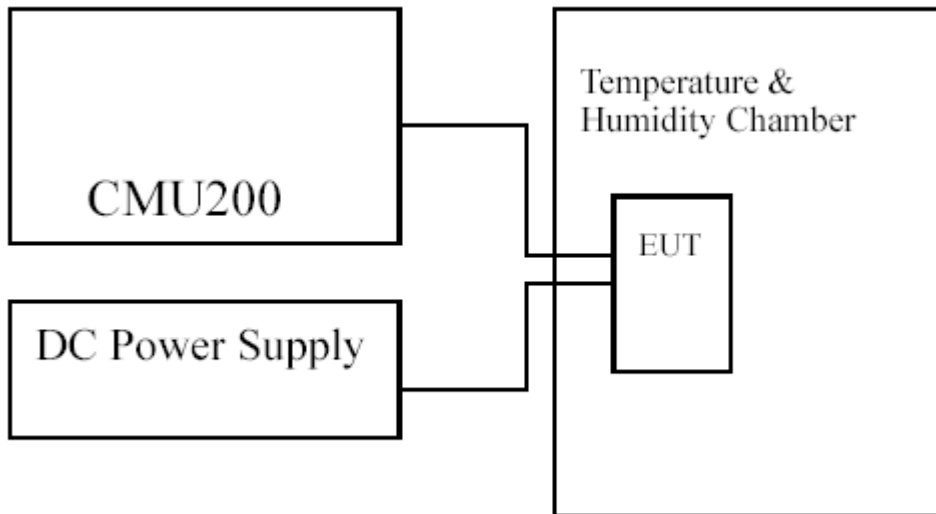

7.3. Limits

Limit	$\pm 1\text{ppm}$
-------	------------------------------

7.4. Test Procedure

The EUT was set to transmit on maximum power. Universal Radio Communication Tester, (CMU200), was used to measure The Frequency Error.

7.5. Test Specification

According to Part 2.1055

7.6. Test Result of Frequency Stability Under Temperature Variations

Product	CDMA Mobile Phone		
Test Mode	Frequency Stability Under Temperature Variations & Voltage Variations		
Date of Test	2006/10/5	Test Site	CB4
Test Condition	CDMA2000 (Channel 380)	Test Range	-30°C ~+50°C

CDMA2000 (800MHz)

Temperature Interval()	Test Frequency (MHz)	Deviation (Hz)	Deviation (ppm)	Limit (ppm)
-30	836.4	+28	0.033	0.1
-20	836.4	+32	0.038	0.1
-10	836.4	+28	0.033	0.1
0	836.4	+32	0.038	0.1
10	836.4	+34	0.041	0.1
20	836.4	+36	0.043	0.1
30	836.4	+32	0.038	0.1
40	836.4	+28	0.033	0.1
50	836.4	+31	0.037	0.1

CDMA2000 (800MHz)

DC Voltage (V)	Test Frequency (MHz)	Deviation (Hz)	Deviation (ppm)	Limit (ppm)
3.145	836.4	+37	0.044	0.1
3.7	836.4	+31	0.037	0.1
4.225	836.4	+34	0.041	0.1

8. EMI Reduction Method During Compliance Testing

No modification was made during testing.

Attachment 1: EUT Test Photographs

Attachment 2: EUT Detailed Photographs