





FCC RADIO TEST REPORT

Applicant : ATBS Technology Co.
Address : 3F., No.200, Gangqian Rd., Neihu District,
Taipei City 11494, Taiwan
Equipment : TPMS for iPod, iPhone, iPad
Model No. : BT6XXXX(X=0-9, A-Z, a-z or blank)
Trade Name : 
FCC ID : UP5-SC-BT6000C

I HEREBY CERTIFY THAT :

The sample was received on Aug. 26, 2016 and the testing was carried out on Sep. 13, 2016 at CerpPASS Technology Corp. The test result refers exclusively to the test presented test model / sample. Without written approval of CerpPASS Technology Corp., the test report shall not be reproduced except in full.

Approved by:

Ray Chou / Assistant Manager

Tested by:

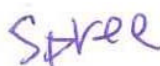
Spree Yei / Engineer

Laboratory Accreditation:

CerpPASS Technology Corporation Test Laboratory





Contents

1. Summary of Test Procedure and Test Results.....	5
1.1 Applicable Standards	5
2. Test Configuration of Equipment under Test.....	6
2.1 Feature of Equipment under Test.....	6
2.2 Carrier Frequency of Channels	6
2.3 Test Mode & Test Software	7
2.4 Description of Test System.....	7
2.5 General Information of Test.....	8
3. Test Equipment and Ancillaries Used for Tests.....	9
4. Antenna Requirements.....	10
4.1 Standard Applicable	10
4.2 Antenna Construction and Directional Gain.....	10
5. Test of AC Power Line Conducted Emission	11
5.1 Test Limit	11
5.2 Test Procedures	11
5.3 Typical Test Setup	12
5.4 Test Result and Data	13
5.5 Test Photographs	15
6. Test of Radiated Spurious Emission.....	16
6.1 Test Limit	16
6.2 Test Procedures.....	16
6.3 Typical Test Setup	17
6.4 Test Result and Data (9kHz ~ 30MHz).....	18
6.5 Test Result and Data (30MHz ~ 1GHz).....	18
6.6 Test Result and Data (1GHz ~ 25GHz).....	20
6.7 Restricted Bands of Operation	32
6.8 Test Photographs (30MHz ~ 1GHz)	33
6.9 Test Photographs (1GHz ~ 25GHz)	34
7. Test of Conducted Spurious Emission	35
7.1 Test Limit	35
7.2 Test Procedure	35
7.3 Test Setup Layout	35
7.4 Test Result and Data	35
8. 20dB Bandwidth Measurement Data.....	43
8.1 Test Limit	43
8.2 Test Procedures	43
8.3 Test Setup Layout	43
8.4 Test Result and Data	43
9. Frequencies Separation	46
9.1 Test Limit	46
9.2 Test Procedures	46
9.3 Test Setup Layout	46



9.4 Test Result and Data 46

10. Dwell Time on each channel 49

10.1 Test Limit 49

10.2 Test Procedures 49

10.3 Test Setup Layout 49

10.4 Test Result and Data 49

11. Number of Hopping Channels 52

11.1 Test Limit 52

11.2 Test Procedures 52

11.3 Test Setup Layout 52

11.4 Test Result and Data 52

12. Maximum Peak Output Power 54

12.1 Test Limit 54

12.2 Test Procedures 54

12.3 Test Setup Layout 54

12.4 Test Result and Data 55



1. Summary of Test Procedure and Test Results

1.1 Applicable Standards

ANSI C63.4:2014

ANSI C63.10:2013

FCC Rules and Regulations Part 15 Subpart C §15.247

FCC Rule	Description of Test	Result
15.203	. Antenna Requirement	Pass
15.207	. AC Power Line Conducted Emission	Pass
15.209 15.205	. Radiated Spurious Emission	Pass
15.247(d)	. Conducted Spurious Emission	Pass
15.247(a)(1)	. Channel Carrier Frequencies Separation	Pass
15.247(a)(1)	. 20dB Bandwidth	Pass
15.247(a)(1)	. Dwell Time	Pass
15.247(b)	. Number of Hopping Channels	Pass
15.247(b)	. Peak Output Power Measurement Data	Pass

This EUT has been also tested and compiled with the requirement of FCC Part 15, Subpart B, recorded in a separate test report.



2. Test Configuration of Equipment under Test

2.1 Feature of Equipment under Test

Modulation Type	GFSK, $\pi/4$ -DQPSK, 8DPSK
Frequency Range	2402MHz~2480MHz
Data Rate	GFSK: 1Mbps $\pi/4$ -DQPSK: 2Mbps 8DPSK: 3Mbps
Antenna Type	PCB Antenna
Antenna Gain	0dBi

2.2 Carrier Frequency of Channels

Channel	Frequency (MHz)	Channel	Frequency (MHz)	Channel	Frequency (MHz)	Channel	Frequency (MHz)
*00	2402	20	2422	40	2442	60	2462
01	2403	21	2423	41	2443	61	2463
02	2404	22	2424	42	2444	62	2464
03	2405	23	2425	43	2445	63	2465
04	2406	24	2426	44	2446	64	2466
05	2407	25	2427	45	2447	65	2467
06	2408	26	2428	46	2448	66	2468
07	2409	27	2429	47	2449	67	2469
08	2410	28	2430	48	2450	68	2470
09	2411	29	2431	49	2451	69	2471
10	2412	30	2432	50	2452	70	2472
11	2413	31	2433	51	2453	71	2473
12	2414	32	2434	52	2454	72	2474
13	2415	33	2435	53	2455	73	2475
14	2416	34	2436	54	2456	74	2476
15	2417	35	2437	55	2457	75	2477
16	2418	36	2438	56	2458	76	2478
17	2419	37	2439	57	2459	77	2479
18	2420	38	2440	58	2460	*78	2480
19	2421	*39	2441	59	2461	---	---

Note: Channels remarked * are selected to perform test.



2.3 Test Mode & Test Software

- a. During testing, the interface cables and equipment positions were varied according to ANSI C63.4
- b. The complete test system included EUT for RF test.
- c. An executive program, "ISRT V2.1.93409" was executed to transmit and receive data via Bluetooth.
- d. The following test modes were performed for the test:
 - Test Mode 1. GFSK (1Mbps)
 - Test Mode 2. $\pi/4$ -DQPSK (2Mbps)
 - Test Mode 3. 8DPSK (3Mbps)

2.4 Description of Test System

The EUT was tested alone. No support devices is needed for testing.



2.5 General Information of Test

Test Site	Cerpass Technology Corporation Test Laboratory Address: No.10, Ln. 2, Lianfu St., Luzhu Dist., Taoyuan City 33848, Taiwan (R.O.C.) Tel:+886-3-3226-888 Fax:+886-3-3226-881 Address: No.68-1, Shihbachongsi, Shihding Township, New Taipei City 223, Taiwan, R.O.C. Tel: +886-2-2663-8582	
	FCC	TW1079, TW1061, 390316, 228391, 641184
	IC	4934E-1, 4934E-2
	VCCI	T-2205 for Telecommunication Test C-4663 for Conducted emission test R-3428, R-4218 for Radiated emission test G-812, G-813 for radiated disturbance above 1GHz
Frequency Range Investigated:	Conducted: from 150kHz to 30 MHz Radiation: from 30 MHz to 25,000MHz	
Test Distance:	The test distance of radiated emission from antenna to EUT is 3 M.	



3. Test Equipment and Ancillaries Used for Tests

Instrument	Model No.	Manufacturer	Serial No.	Calibration Date	Valid Date
Bilog Antenna	Schwarzbeck	VULB9168	369	2016/03/22	2017/03/21
Active Loop Antenna	EMCO	6507	40855	2016/03/11	2017/03/10
Horn Antenna	EMCO	3116	31589	2016/03/22	2017/03/21
EXA Signal Analyzer	KEYSIGHT	N9010A	MY54200207	2016/03/16	2017/03/15
Preamplifier	EM	EM330	060659	2016/03/23	2017/03/22
Preamplifier	MITEQ	AMF-7D-001 0100-30-10P	1860212	2016/03/16	2017/03/15
Preamplifier	EMC INSTRUMENTS	EMC184045	980065	2015/11/04	2016/11/03
MXG MW Analog Signal Generator	KEYSIGHT	N5183A	MY50142931	2016/03/18	2017/03/17
MXG-B RF Vector Signal Generator	KEYSIGHT	N5182B	MY53051383	2016/03/18	2017/03/17
Spectrum Analyzer	R&S	FSP40	100047	2016/03/05	2017/03/04
BLUETOOTH TESTER	R&S	CBT	101133	2016/03/18	2017/03/17
Attenuator	KEYSIGHT	8491B	MY39250703	2016/03/07	2017/03/06
Rotary Attenuator	Agilent	8494B	MY42154466	2016/03/80	2017/03/07
Rotary Attenuator	Agilent	8495B	MY42146680	2016/03/08	2017/03/07
Temp & Humi chamber	T-MACHINE	TMJ-9712	T-12-040111	2016/09/05	2017/09/04
Series Power Meter	Anritsu	ML2495A	1224005	2016/03/03	2017/03/02
Power Sensor	Anritsu	MA2411B	1207295	2016/03/03	2017/03/02
USB Average Power Sensor	Theda	4PS6A	TW5451013~16	2014/11/08	2016/11/07
Software	AUDIX	E3	V8.2014-8-6	N/A	N/A
Software	Keysight	Console	v0.01	N/A	N/A
Software	Keysight	ETSI Standard Test System	v3.160422	N/A	N/A
Software	Keysight	N7607B Signal Studio	v2.0.0.1	N/A	N/A
Software	Keysight	Inservice Monitor Utility	N/A	N/A	N/A



4. Antenna Requirements

4.1 Standard Applicable

For intentional device, according to FCC 47 CFR Section 15.203, an intentional radiator shall be designed to ensure that no antenna other than that furnished by the responsible party shall be used with the device.

And according to FCC 47 CFR Section 15.247 (b), if transmitting antennas of directional gain greater than 6dBi are used, the power shall be reduced by the amount in dB that the directional gain of the antenna exceeds 6dBi.

4.2 Antenna Construction and Directional Gain

Antenna Type	Antenna Gain
PCB Antenna	0 dBi



5. Test of AC Power Line Conducted Emission

5.1 Test Limit

Conducted Emissions were measured from 150 kHz to 30 MHz with a bandwidth of 9 KHz, according to the methods defined in ANSI C63.4-2014. The EUT was placed on a nonmetallic stand in a shielded room 0.8 meters above the ground plane. The interface cables and equipment positioning were varied within limits of reasonable applications to determine the position produced maximum conducted emissions.

Frequency (MHz)	Quasi Peak (dB μ V)	Average (dB μ V)
0.15 – 0.5	66-56*	56-46*
0.5 – 5.0	56	46
5.0 – 30.0	60	50

*Decreases with the logarithm of the frequency.

5.2 Test Procedures

- a. The EUT was placed 0.4 meter from the conducting wall of the shielding room was kept at least 80 centimeters from any other grounded conducting surface.
- b. Connect EUT to the power mains through a line impedance stabilization network (LISN).
- c. All the support units are connecting to the other LISN.
- d. The LISN provides 50 ohm coupling impedance for the measuring instrument.
- e. The FCC states that a 50 ohm, 50 micro-Henry LISN should be used.
- f. Both sides of AC line were checked for maximum conducted interference.
- g. The frequency range from 150 kHz to 30 MHz was searched.
- h. Set the test-receiver system to Peak Detect Function and Specified Bandwidth with Maximum Hold Mode.



5.3 Typical Test Setup

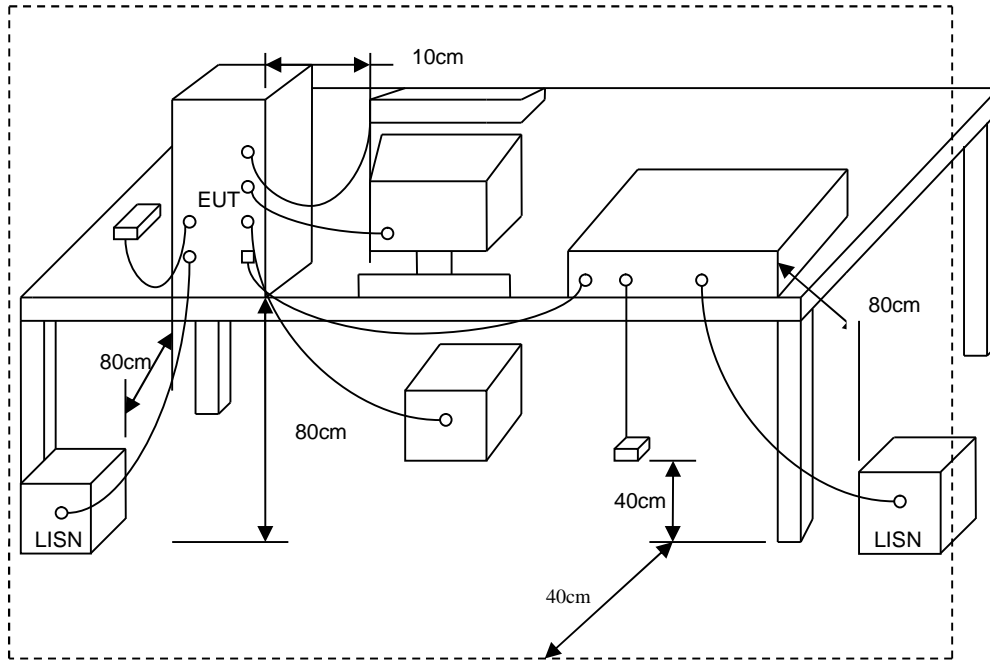



5.4 Test Result and Data

Power	: AC 120V	Pol/Phase	: LINE
Test Mode	: TX	Temperature	: 23 °C
Test date	: Sep. 13, 2016	Humidity	: 56 %
Memo	: CH00	Atmospheric Pressure	: 1008 hPa

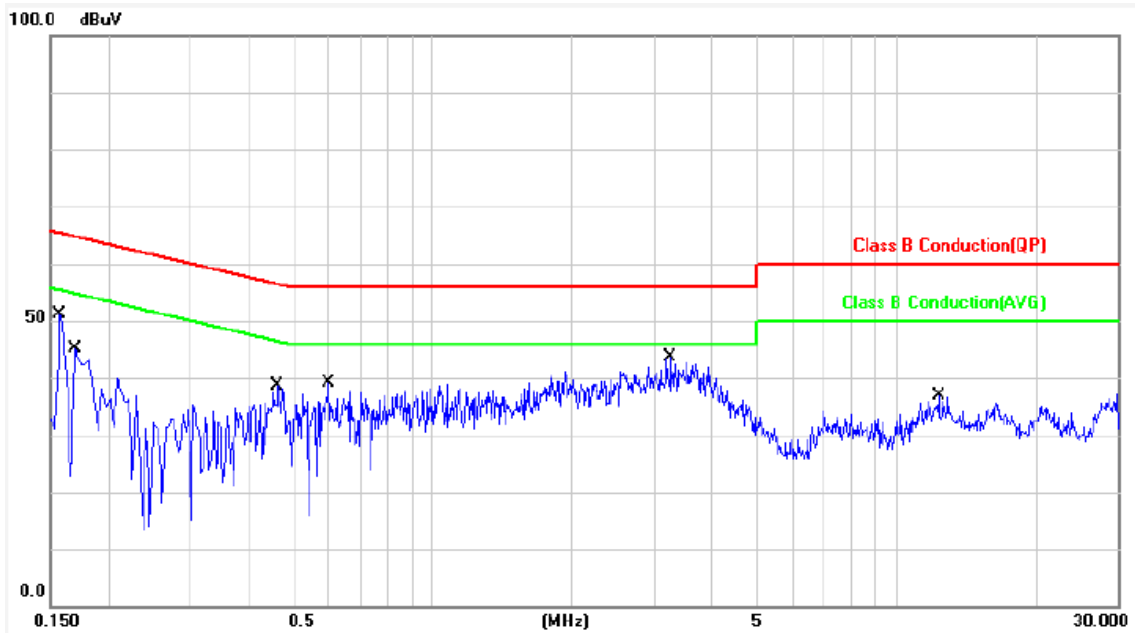

No.	Frequency (MHz)	Factor (dB)	Reading (dBuV)	Level (dBuV)	Limit (dBuV)	Margin (dB)	Detector	P/F
1	0.1580	9.93	36.43	46.36	65.56	-19.20	QP	P
2	0.1580	9.93	13.87	23.80	55.56	-31.76	AVG	P
3	0.1700	9.93	32.78	42.71	64.96	-22.25	QP	P
4	0.1700	9.93	11.21	21.14	54.96	-33.82	AVG	P
5	0.4660	9.94	25.85	35.79	56.58	-20.79	QP	P
6	0.4660	9.94	12.64	22.58	46.58	-24.00	AVG	P
7	0.5980	9.95	25.03	34.98	56.00	-21.02	QP	P
8	0.5980	9.95	12.26	22.21	46.00	-23.79	AVG	P
9	3.2740	10.11	26.91	37.02	56.00	-18.98	QP	P
10	3.2740	10.11	19.39	29.50	46.00	-16.50	AVG	P
11	12.3700	10.40	19.54	29.94	60.00	-30.06	QP	P
12	12.3700	10.40	12.57	22.97	50.00	-27.03	AVG	P

Note: Level = Reading + Factor
 Margin = Level – Limit
 Factor = (LISN, ISN, PLC or current probe) Factor + Cable Loss



Power	: AC 120V	Pol/Phase	: NEUTRAL
Test Mode	: TX	Temperature	: 23 °C
Test date	: Sep. 13, 2016	Humidity	: 56 %
Memo	: CH00	Atmospheric Pressure	: 1008 hPa

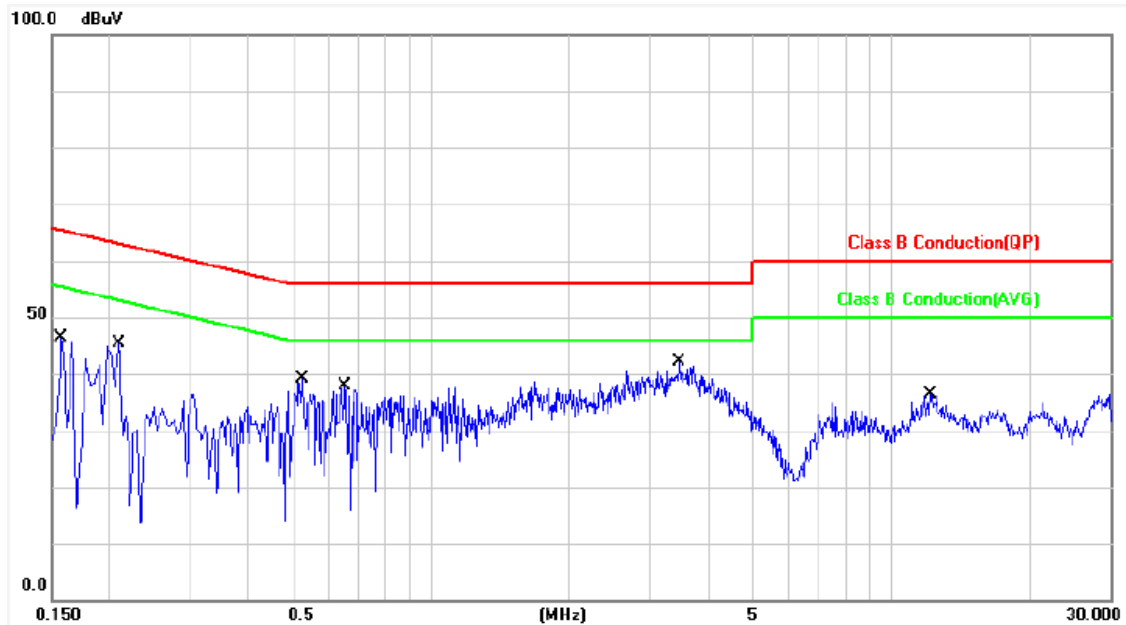

No.	Frequency (MHz)	Factor (dB)	Reading (dBUV)	Level (dBUV)	Limit (dBUV)	Margin (dB)	Detector	P/F
1	0.1580	9.93	34.89	44.82	65.56	-20.74	QP	P
2	0.1580	9.93	13.27	23.20	55.56	-32.36	AVG	P
3	0.2100	9.93	29.24	39.17	63.20	-24.03	QP	P
4	0.2100	9.93	11.90	21.83	53.20	-31.37	AVG	P
5	0.5260	9.94	26.97	36.91	56.00	-19.09	QP	P
6	0.5260	9.94	14.06	24.00	46.00	-22.00	AVG	P
7	0.6540	9.95	25.08	35.03	56.00	-20.97	QP	P
8	0.6540	9.95	12.52	22.47	46.00	-23.53	AVG	P
9	3.4820	10.09	25.57	35.66	56.00	-20.34	QP	P
10	3.4820	10.09	18.58	28.67	46.00	-17.33	AVG	P
11	12.2299	10.41	19.94	30.35	60.00	-29.65	QP	P
12	12.2299	10.41	13.32	23.73	50.00	-26.27	AVG	P

Note: Level = Reading + Factor
 Margin = Level – Limit
 Factor = (LISN, ISN, PLC or current probe) Factor + Cable Loss



6. Test of Radiated Spurious Emission

6.1 Test Limit

Radiated emissions from 30 MHz to 25 GHz were measured according to the methods defines in ANSI C63.4-2014. The EUT was placed, 0.8 meter above the ground plane, as shown in section 5.6.3. The interface cables and equipment positions were varied within limits of reasonable applications to determine the positions producing maximum radiated emissions For unintentional device, according to § 15.109(a), except for Class A digital devices, the field strength of radiated emissions from unintentional radiators at a distance of 3 meters shall not exceed the following values:

Frequency (MHz)	Distance Meters	Radiated (μ V / M)	Radiated (dB μ V / M)
30-88	3	100	40.0
88-216	3	150	43.5
216-960	3	200	46.0
Above 960	3	500	54.0

For unintentional device, according to CISPR PUB.22, for Class B digital devices, the general requirement of field strength of radiated emissions from intentional radiators at a distance of 10 meters shall not exceed the above table.

Frequency (MHz)	Distance Meters	Radiated (dB μ V / M)
30-230	10	30
230-1000	10	37

6.2 Test Procedures

- The EUT was placed on a rotatable table top 0.8 meter above ground.
- The EUT was set 3 meters from the interference receiving antenna which was mounted on the top of a variable height antenna tower.
- The table was rotated 360 degrees to determine the position of the highest radiation.
- The antenna is a broadband antenna and its height is varied between one meter and four meters above ground to find the maximum value of the field strength both horizontal polarization and vertical polarization of the antenna are set to make the measurement.
- For each suspected emission the EUT was arranged to its worst case and then tune the antenna tower (from 1 M to 4 M) and turn table (from 0 degree to 360 degrees) to find the maximum reading.
- Set the test-receiver system to Peak or CISPR quasi-peak Detect Function and specified bandwidth with Maximum Hold Mode.
- If the emission level of the EUT in peak mode was 3 dB lower than the limit specified, then testing will be stopped and peak values of EUT will be reported, otherwise, the emissions which do not have 3 dB margin will be repeated one by one using the quasi-peak method and reported.
- For testing above 1GHz, the emission level of the EUT in peak mode was 20dB lower than average limit (that means the emission level in peak mode also complies with the limit in average mode), then testing will be stopped and peak values of EUT will be reported, otherwise, the emissions will be measured in average mode again and reported.



6.3 Typical Test Setup

Below 30MHz test setup

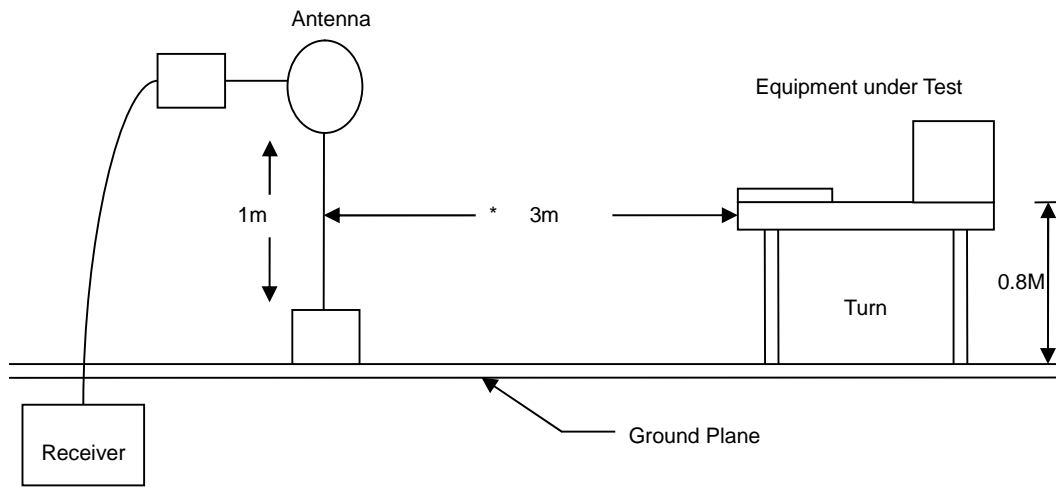

30MHz- 1GHz Test Setup

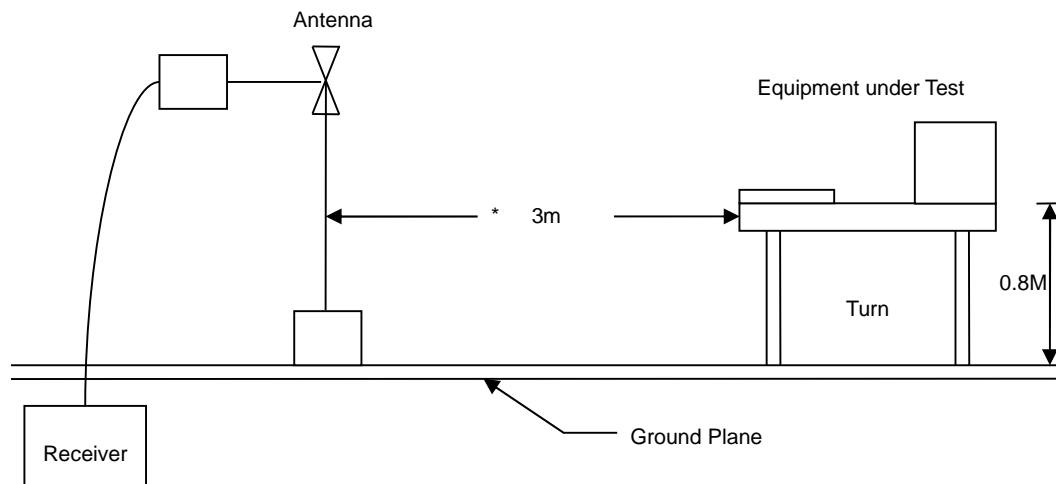

Above 1GHz Test Setup

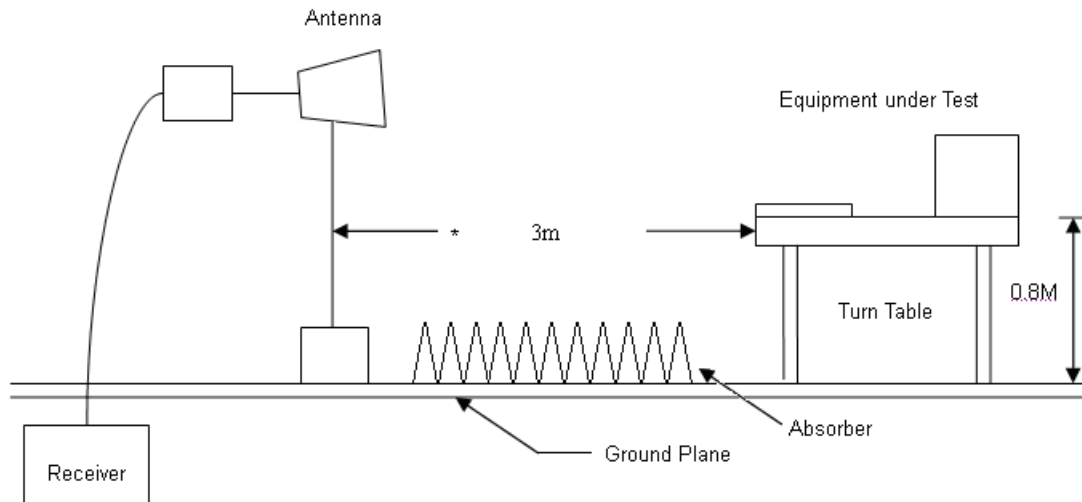



6.4 Test Result and Data (9kHz ~ 30MHz)

The 9kHz-30MHz spurious emission is under limit 20dB more.

6.5 Test Result and Data (30MHz ~ 1GHz)

Power	: AC 120V	Pol/Phase	: VERTICAL
Test Mode	: TX	Temperature	: 20 °C
Test Date	: Sep. 12, 2016	Humidity	: 63 %
Memo	: CH00	Atmospheric Pressure	: 1008 hPa

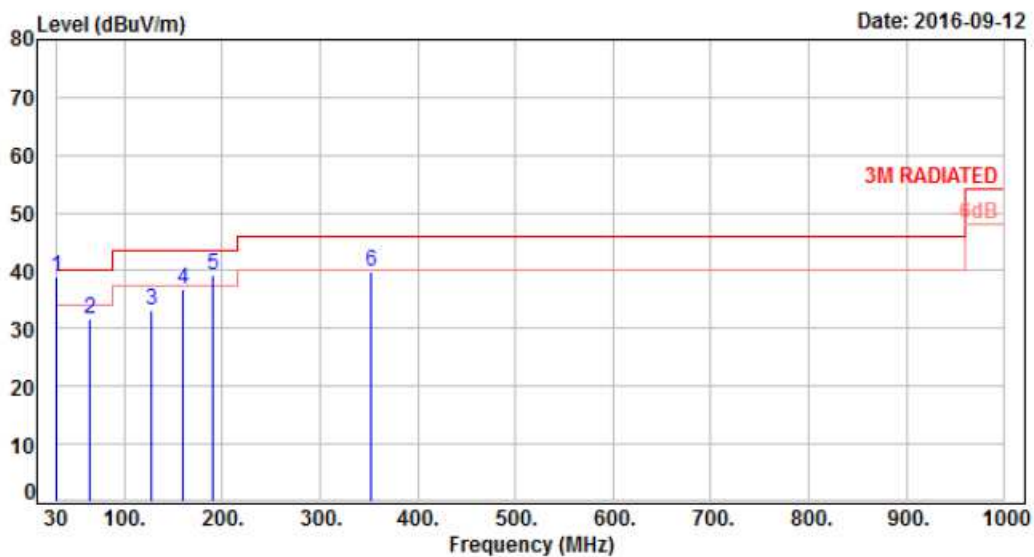

No.	Frequency (MHz)	Factor (dB)	Reading (dBuV)	Level (dBuV)	Limit (dBuV)	Margin (dB)	Detector	Height (cm)	Azimuth (deg)	P/F
1	30.00	-10.73	49.62	38.89	40.00	-1.11	QP	121	145	P
2	64.92	-11.45	43.11	31.66	40.00	-8.34	Peak	400	0	P
3	127.00	-11.83	45.06	33.23	43.50	-10.27	Peak	400	0	P
4	159.98	-9.89	46.69	36.80	43.50	-6.70	Peak	400	0	P
5	191.02	-12.24	51.63	39.39	43.50	-4.11	QP	126	242	P
6	352.04	-7.71	47.46	39.75	46.00	-6.25	Peak	400	0	P

Note: Level=Reading+Factor
Margin=Level-Limit
Factor=Antenna Factor + cable loss - Amplifier Factor



Power	: AC 120V	Pol/Phase	: HORIZONTAL
Test Mode	: TX	Temperature	: 20 °C
Test Date	: Sep. 12, 2016	Humidity	: 63 %
Memo	: CH00	Atmospheric Pressure	: 1008 hPa

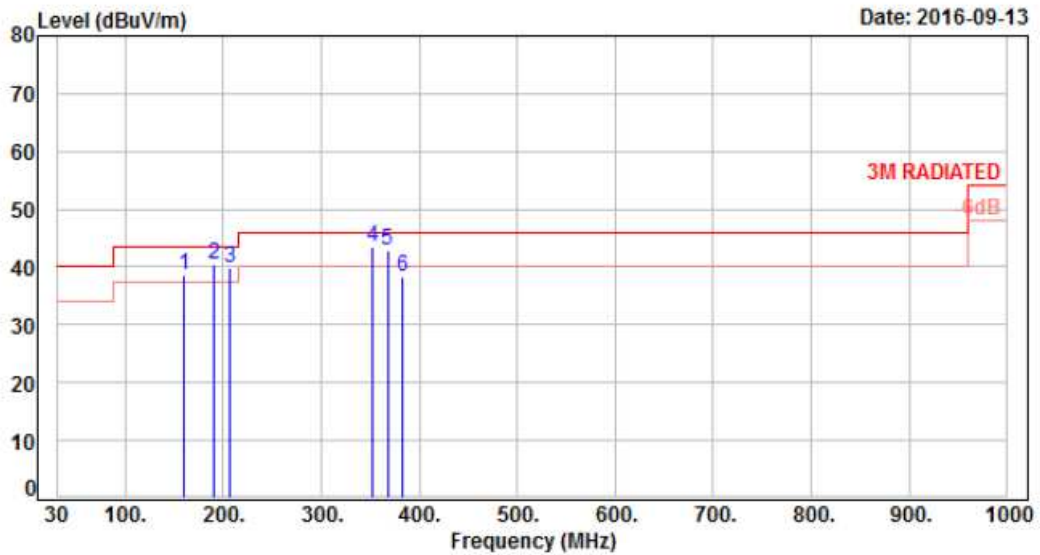

No.	Frequency (MHz)	Factor (dB)	Reading (dBuV)	Level (dBuV)	Limit (dBuV)	Margin (dB)	Detector	Height (cm)	Azimuth (deg)	P/F
1	159.98	-9.89	48.52	38.63	43.50	-4.87	QP	102	147	P
2	191.02	-12.24	52.56	40.32	43.50	-3.18	QP	124	212	P
3	206.54	-12.62	52.39	39.77	43.50	-3.73	QP	137	129	P
4	352.04	-7.71	51.23	43.52	46.00	-2.48	QP	102	148	P
5	367.56	-7.28	50.14	42.86	46.00	-3.14	QP	141	256	P
6	383.08	-6.86	45.31	38.45	46.00	-7.55	Peak	400	0	P

Note: Level=Reading+Factor
Margin=Level-Limit
Factor=Antenna Factor + cable loss - Amplifier Factor



6.6 Test Result and Data (1GHz ~ 25GHz)

Power	: AC 120V	Pol/Phase	: VERTICAL
Test Mode	: GFSK	Temperature	: 20 °C
Test Date	: Aug. 26, 2016	Humidity	: 63 %
Memo	: CH00	Atmospheric Pressure	: 1008 hPa

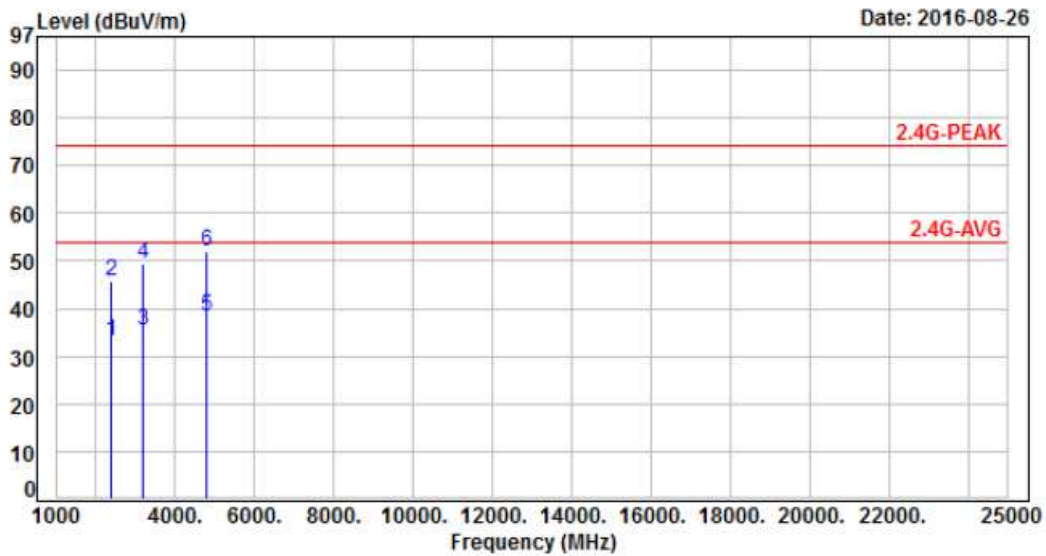

No.	Frequency (MHz)	Factor (dB)	Reading (dBuV)	Level (dBuV)	Limit (dBuV)	Margin (dB)	Detector	Height (cm)	Azimuth (deg)	P/F
1	2390.00	-0.94	34.11	33.17	54.00	-20.83	Average	322	233	P
2	2390.00	-0.94	46.57	45.63	74.00	-28.37	Peak	322	233	P
3	3202.67	2.72	32.60	35.32	54.00	-18.68	Average	169	205	P
4	3202.67	2.72	46.85	49.57	74.00	-24.43	Peak	169	205	P
5	4804.00	7.84	30.54	38.38	54.00	-15.62	Average	213	159	P
6	4804.00	7.84	44.18	52.02	74.00	-21.98	Peak	213	159	P

Note: Level=Reading+Factor
 Margin=Level-Limit
 Factor=Antenna Factor + cable loss - Amplifier Factor



Power	: AC 120V	Pol/Phase	: HORIZONTAL
Test Mode	: GFSK	Temperature	: 20 °C
Test Date	: Aug. 26, 2016	Humidity	: 63 %
Memo	: CH00	Atmospheric Pressure	: 1008 hPa

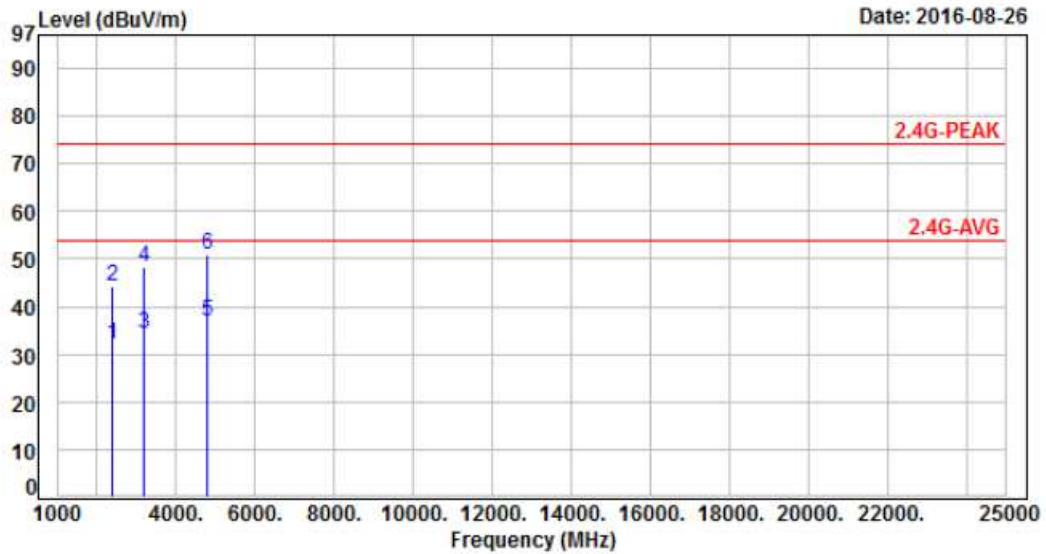

No.	Frequency (MHz)	Factor (dB)	Reading (dBuV)	Level (dBuV)	Limit (dBuV)	Margin (dB)	Detector	Height (cm)	Azimuth (deg)	P/F
1	2390.00	-0.94	32.89	31.95	54.00	-22.05	Average	267	165	P
2	2390.00	-0.94	45.23	44.29	74.00	-29.71	Peak	267	165	P
3	3202.67	2.72	31.65	34.37	54.00	-19.63	Average	148	212	P
4	3202.67	2.72	45.68	48.40	74.00	-25.60	Peak	148	212	P
5	4804.00	7.84	29.13	36.97	54.00	-17.03	Average	312	102	P
6	4804.00	7.84	43.06	50.90	74.00	-23.10	Peak	312	102	P

Note: Level=Reading+Factor
Margin=Level-Limit
Factor=Antenna Factor + cable loss - Amplifier Factor



Power	: AC 120V	Pol/Phase	: VERTICAL
Test Mode	: GFSK	Temperature	: 20 °C
Test Date	: Aug. 26, 2016	Humidity	: 63 %
Memo	: CH39	Atmospheric Pressure	: 1008 hPa

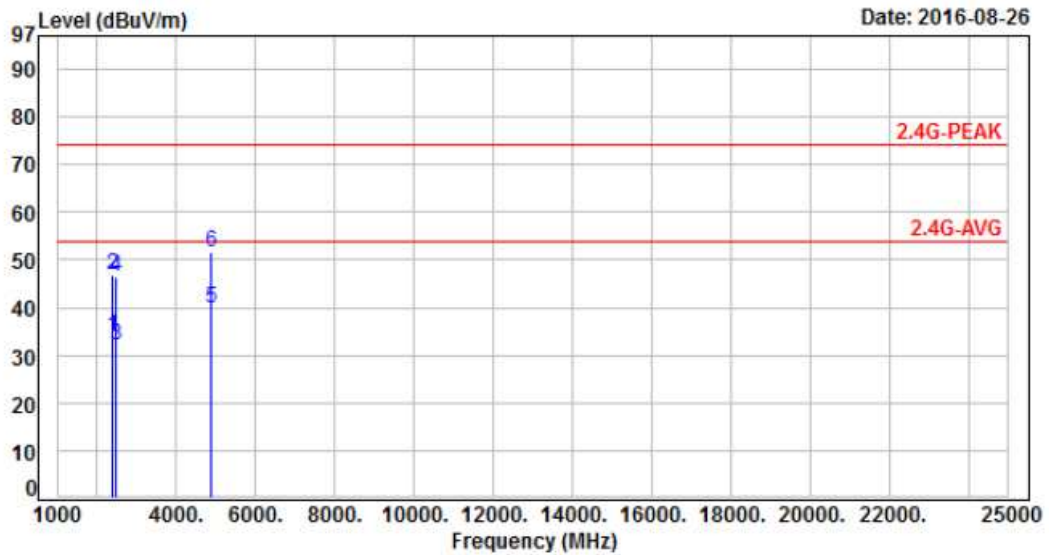

No.	Frequency (MHz)	Factor (dB)	Reading (dBuV)	Level (dBuV)	Limit (dBuV)	Margin (dB)	Detector	Height (cm)	Azimuth (deg)	P/F
1	2390.00	-0.94	34.75	33.81	54.00	-20.19	Average	167	149	P
2	2390.00	-0.94	47.95	47.01	74.00	-26.99	Peak	184	156	P
3	2483.50	-0.64	32.67	32.03	54.00	-21.97	Average	184	156	P
4	2483.50	-0.64	47.14	46.50	74.00	-27.50	Peak	184	156	P
5	4882.00	8.23	31.76	39.99	54.00	-14.01	Average	216	302	P
6	4882.00	8.23	43.47	51.70	74.00	-22.30	Peak	216	302	P

Note: Level=Reading+Factor
 Margin=Level-Limit
 Factor=Antenna Factor + cable loss - Amplifier Factor



Power	: AC 120V	Pol/Phase	: HORIZONTAL
Test Mode	: GFSK	Temperature	: 20 °C
Test Date	: Aug. 26, 2016	Humidity	: 63 %
Memo	: CH39	Atmospheric Pressure	: 1008 hPa

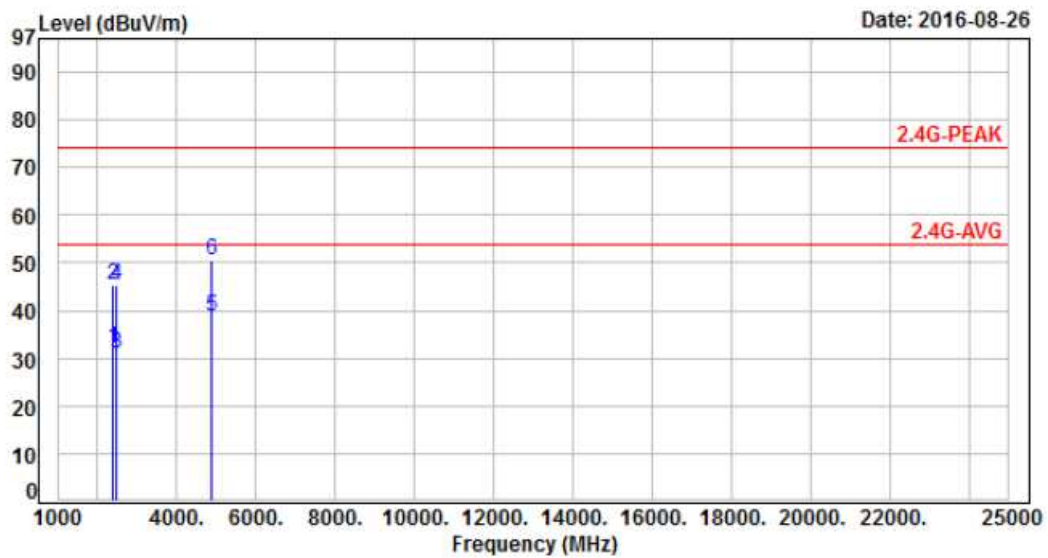

No.	Frequency (MHz)	Factor (dB)	Reading (dBuV)	Level (dBuV)	Limit (dBuV)	Margin (dB)	Detector	Height (cm)	Azimuth (deg)	P/F
1	2390.00	-0.94	33.13	32.19	54.00	-21.81	Average	212	289	P
2	2390.00	-0.94	46.29	45.35	74.00	-28.65	Peak	212	289	P
3	2483.50	-0.64	31.51	30.87	54.00	-23.13	Average	156	201	P
4	2483.50	-0.64	46.02	45.38	74.00	-28.62	Peak	156	201	P
5	4882.00	8.23	30.58	38.81	54.00	-15.19	Average	288	252	P
6	4882.00	8.23	42.12	50.35	74.00	-23.65	Peak	288	252	P

Note: Level=Reading+Factor
 Margin=Level-Limit
 Factor=Antenna Factor + cable loss - Amplifier Factor



Power	: AC 120V	Pol/Phase	: VERTICAL
Test Mode	: GFSK	Temperature	: 20 °C
Test Date	: Aug. 26, 2016	Humidity	: 63 %
Memo	: CH78	Atmospheric Pressure	: 1008 hPa

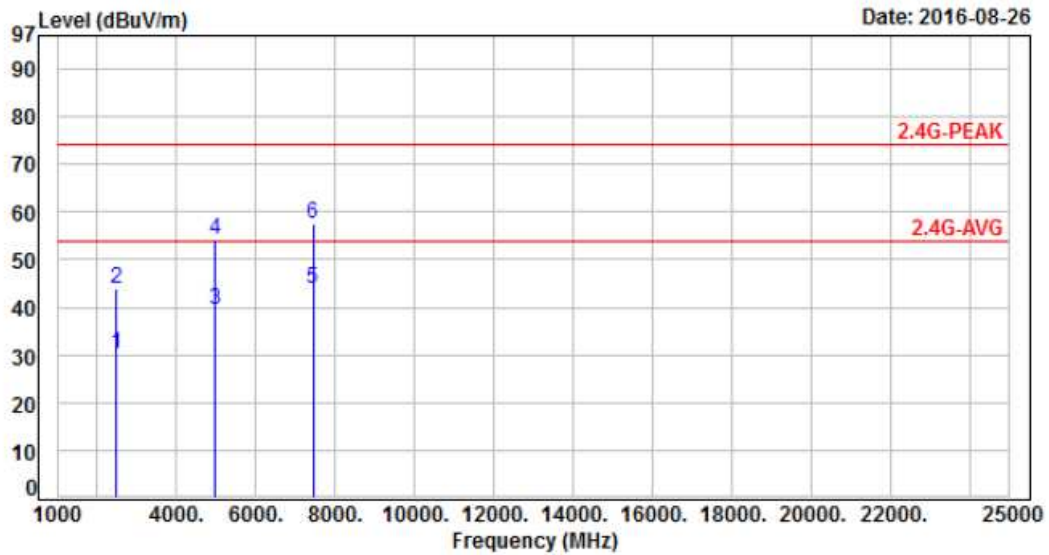

No.	Frequency (MHz)	Factor (dB)	Reading (dBuV)	Level (dBuV)	Limit (dBuV)	Margin (dB)	Detector	Height (cm)	Azimuth (deg)	P/F
1	2483.50	-0.64	30.82	30.18	54.00	-23.82	Average	237	187	P
2	2483.50	-0.64	44.40	43.76	74.00	-30.24	Peak	237	187	P
3	4960.00	8.61	30.78	39.39	54.00	-14.61	Average	212	197	P
4	4960.00	8.61	45.59	54.20	74.00	-19.80	Peak	212	197	P
5	7440.00	12.38	31.49	43.87	54.00	-10.13	Average	269	212	P
6	7440.00	12.38	44.99	57.37	74.00	-16.63	Peak	269	212	P

Note: Level=Reading+Factor
 Margin=Level-Limit
 Factor=Antenna Factor + cable loss - Amplifier Factor



Power	: AC 120V	Pol/Phase	: HORIZONTAL
Test Mode	: GFSK	Temperature	: 20 °C
Test Date	: Aug. 26, 2016	Humidity	: 63 %
Memo	: CH78	Atmospheric Pressure	: 1008 hPa

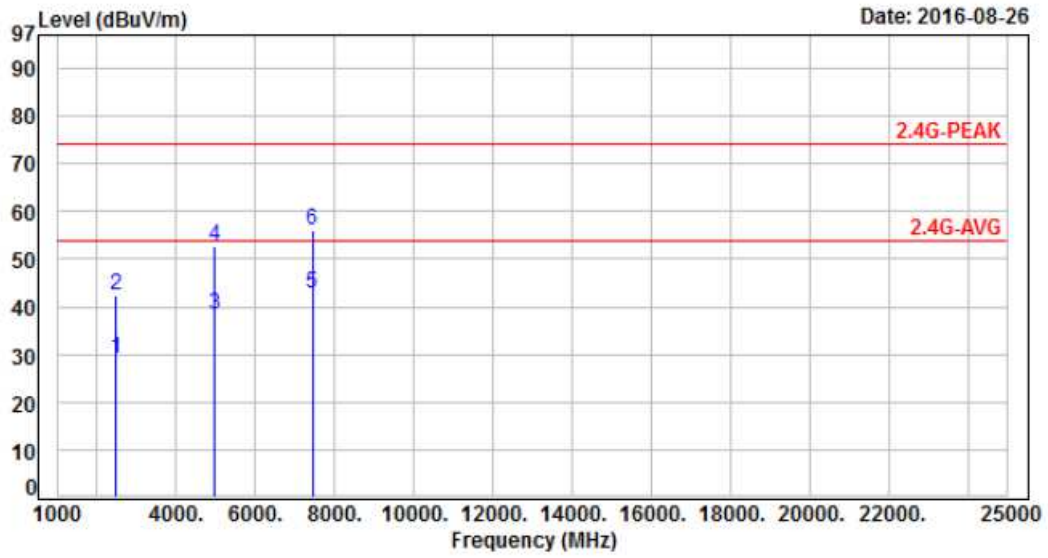

No.	Frequency (MHz)	Factor (dB)	Reading (dBuV)	Level (dBuV)	Limit (dBuV)	Margin (dB)	Detector	Height (cm)	Azimuth (deg)	P/F
1	2483.50	-0.64	29.78	29.14	54.00	-24.86	Average	164	255	P
2	2483.50	-0.64	43.20	42.56	74.00	-31.44	Peak	164	255	P
3	4960.00	8.61	29.89	38.50	54.00	-15.50	Average	149	278	P
4	4960.00	8.61	44.31	52.92	74.00	-21.08	Peak	149	278	P
5	7440.00	12.38	30.23	42.61	54.00	-11.39	Average	173	156	P
6	7440.00	12.38	43.63	56.01	74.00	-17.99	Peak	173	156	P

Note: Level=Reading+Factor
Margin=Level-Limit
Factor=Antenna Factor + cable loss - Amplifier Factor



Power	: AC 120V	Pol/Phase	: VERTICAL
Test Mode	: 8DPSK	Temperature	: 20 °C
Test Date	: Aug. 26, 2016	Humidity	: 63 %
Memo	: CH00	Atmospheric Pressure	: 1008 hPa

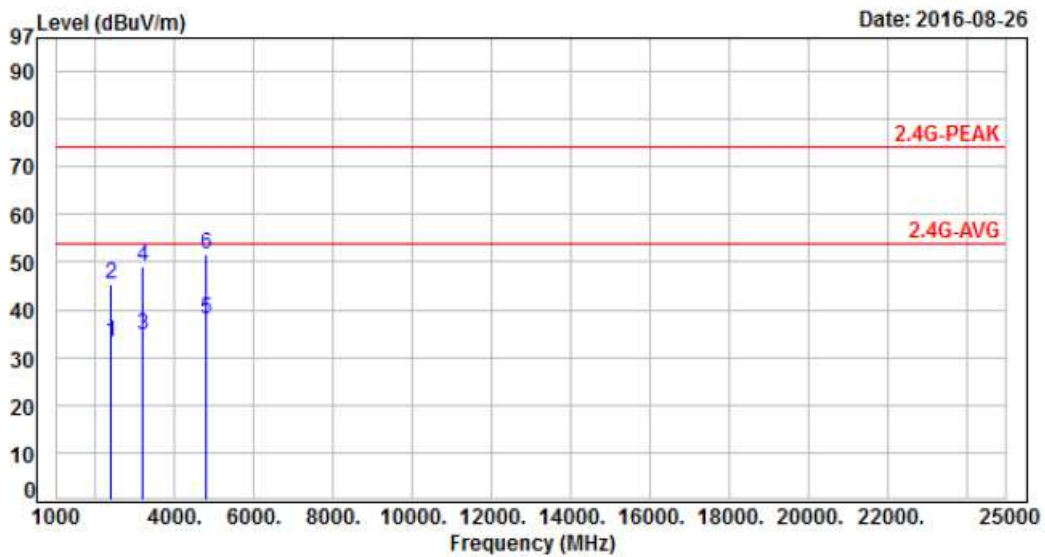

No.	Frequency (MHz)	Factor (dB)	Reading (dBuV)	Level (dBuV)	Limit (dBuV)	Margin (dB)	Detector	Height (cm)	Azimuth (deg)	P/F
1	2390.00	-0.94	33.98	33.04	54.00	-20.96	Average	312	254	P
2	2390.00	-0.94	46.32	45.38	74.00	-28.62	Peak	312	254	P
3	3202.67	2.72	31.85	34.57	54.00	-19.43	Average	172	216	P
4	3202.67	2.72	46.48	49.20	74.00	-24.80	Peak	172	216	P
5	4804.00	7.84	30.14	37.98	54.00	-16.02	Average	215	165	P
6	4804.00	7.84	43.82	51.66	74.00	-22.34	Peak	215	165	P

Note: Level=Reading+Factor
 Margin=Level-Limit
 Factor=Antenna Factor + cable loss - Amplifier Factor



Power	: AC 120V	Pol/Phase	: HORIZONTAL
Test Mode	: 8DPSK	Temperature	: 20 °C
Test Date	: Aug. 26, 2016	Humidity	: 63 %
Memo	: CH00	Atmospheric Pressure	: 1008 hPa

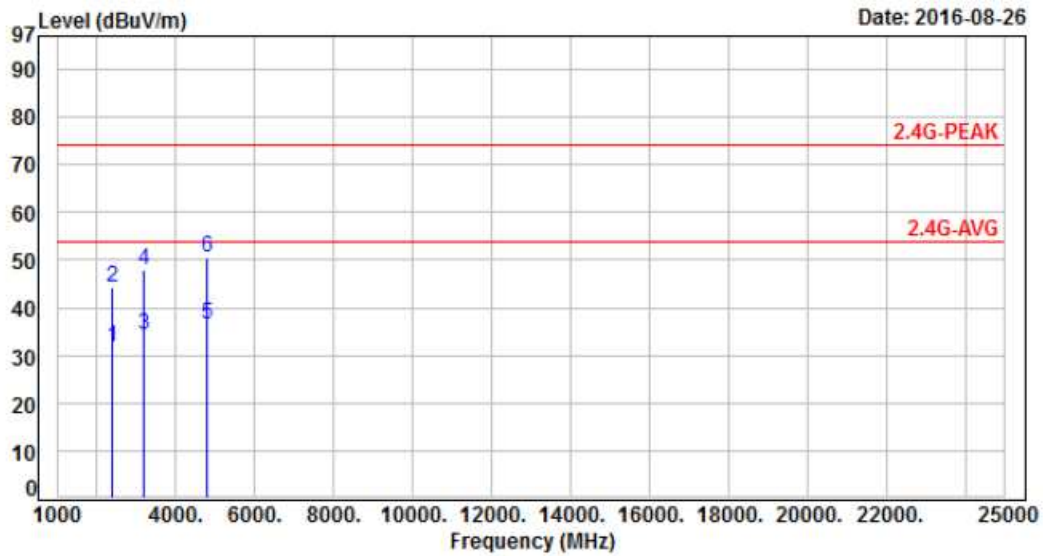

No.	Frequency (MHz)	Factor (dB)	Reading (dBUV)	Level (dBUV)	Limit (dBUV)	Margin (dB)	Detector	Height (cm)	Azimuth (deg)	P/F
1	2390.00	-0.94	32.66	31.72	54.00	-22.28	Average	262	161	P
2	2390.00	-0.94	45.02	44.08	74.00	-29.92	Peak	262	161	P
3	3202.67	2.72	31.49	34.21	54.00	-19.79	Average	152	210	P
4	3202.67	2.72	45.33	48.05	74.00	-25.95	Peak	152	210	P
5	4804.00	7.84	28.84	36.68	54.00	-17.32	Average	315	120	P
6	4804.00	7.84	42.80	50.64	74.00	-23.36	Peak	315	120	P

Note: Level=Reading+Factor
Margin=Level-Limit
Factor=Antenna Factor + cable loss - Amplifier Factor



Power	: AC 120V	Pol/Phase	: VERTICAL
Test Mode	: 8DPSK	Temperature	: 20 °C
Test Date	: Aug. 26, 2016	Humidity	: 63 %
Memo	: CH39	Atmospheric Pressure	: 1008 hPa

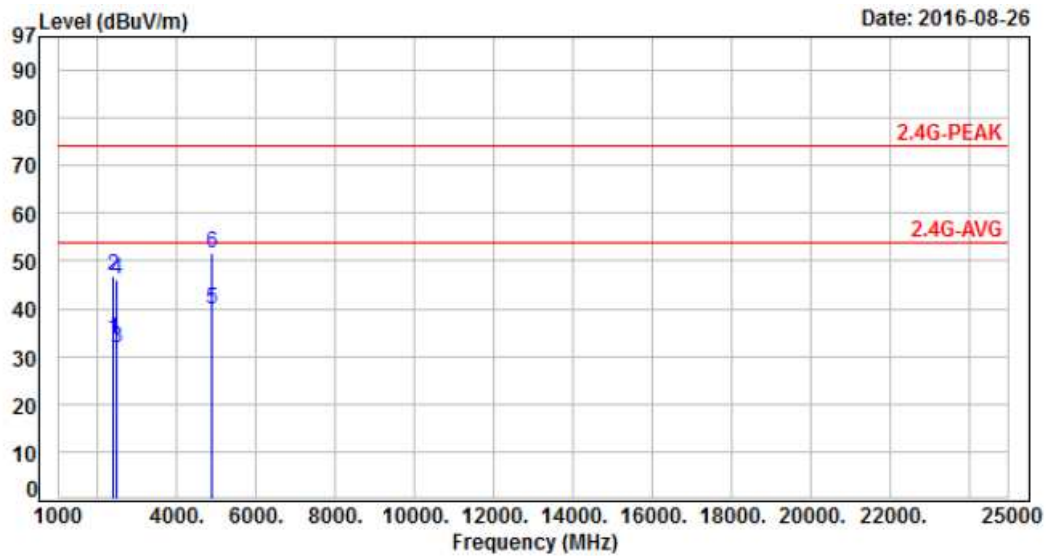

No.	Frequency (MHz)	Factor (dB)	Reading (dBuV)	Level (dBuV)	Limit (dBuV)	Margin (dB)	Detector	Height (cm)	Azimuth (deg)	P/F
1	2390.00	-0.94	34.45	33.51	54.00	-20.49	Average	169	150	P
2	2390.00	-0.94	47.66	46.72	74.00	-27.28	Peak	169	150	P
3	2483.50	-0.64	32.38	31.74	54.00	-22.26	Average	190	155	P
4	2483.50	-0.64	46.71	46.07	74.00	-27.93	Peak	190	155	P
5	4882.00	8.23	31.55	39.78	54.00	-14.22	Average	218	312	P
6	4882.00	8.23	43.25	51.48	74.00	-22.52	Peak	218	312	P

Note: Level=Reading+Factor
 Margin=Level-Limit
 Factor=Antenna Factor + cable loss - Amplifier Factor



Power	: AC 120V	Pol/Phase	: HORIZONTAL
Test Mode	: 8DPSK	Temperature	: 20 °C
Test Date	: Aug. 26, 2016	Humidity	: 63 %
Memo	: CH39	Atmospheric Pressure	: 1008 hPa

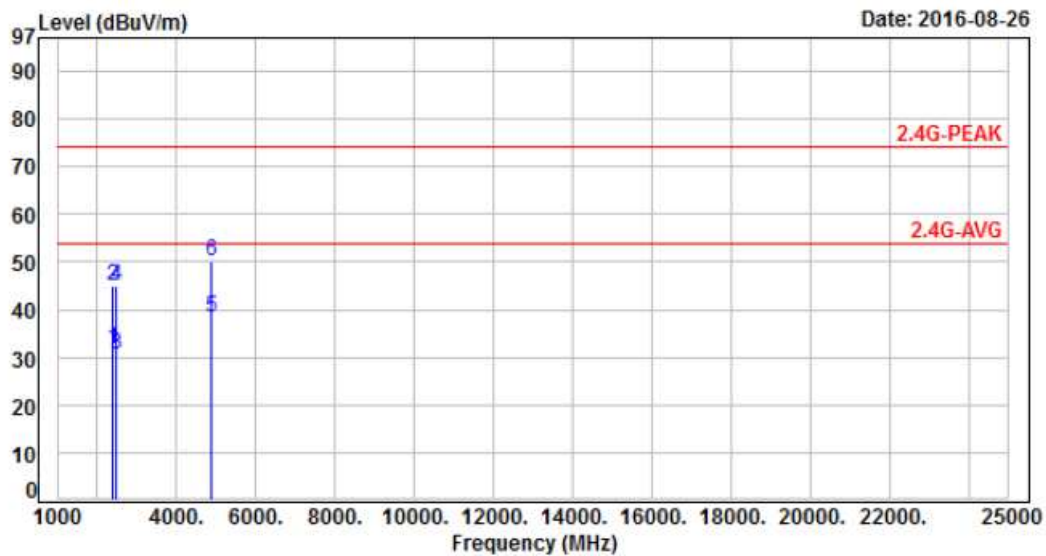

No.	Frequency (MHz)	Factor (dB)	Reading (dBuV)	Level (dBuV)	Limit (dBuV)	Margin (dB)	Detector	Height (cm)	Azimuth (deg)	P/F
1	2390.00	-0.94	32.79	31.85	54.00	-22.15	Average	216	295	P
2	2390.00	-0.94	45.93	44.99	74.00	-29.01	Peak	216	295	P
3	2483.50	-0.64	31.23	30.59	54.00	-23.41	Average	158	242	P
4	2483.50	-0.64	45.72	45.08	74.00	-28.92	Peak	158	242	P
5	4882.00	8.23	30.13	38.36	54.00	-15.64	Average	287	248	P
6	4882.00	8.23	41.84	50.07	74.00	-23.93	Peak	287	248	P

Note: Level=Reading+Factor
 Margin=Level-Limit
 Factor=Antenna Factor + cable loss - Amplifier Factor



Power	: AC 120V	Pol/Phase	: VERTICAL
Test Mode	: 8DPSK	Temperature	: 20 °C
Test Date	: Aug. 26, 2016	Humidity	: 63 %
Memo	: CH78	Atmospheric Pressure	: 1008 hPa

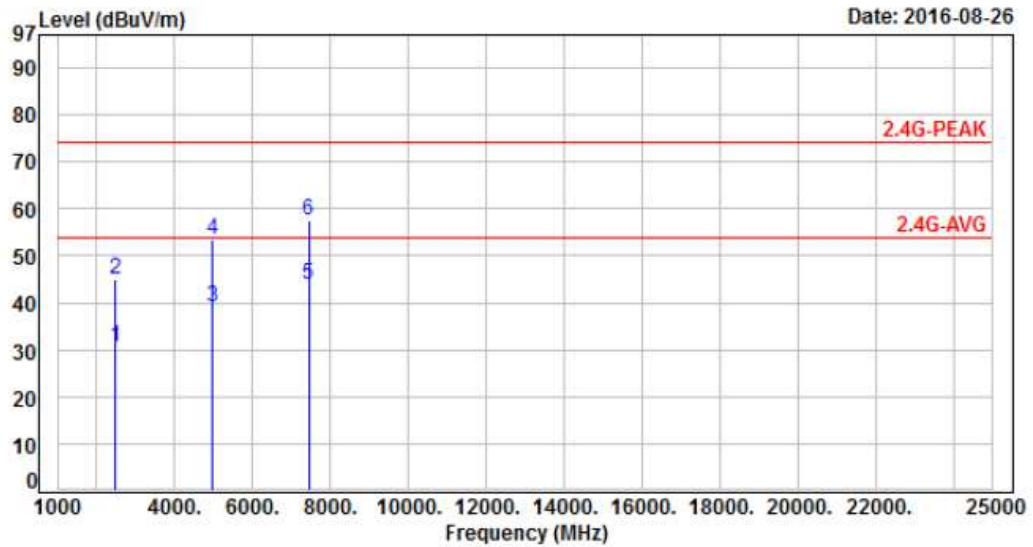

No.	Frequency (MHz)	Factor (dB)	Reading (dBuV)	Level (dBuV)	Limit (dBuV)	Margin (dB)	Detector	Height (cm)	Azimuth (deg)	P/F
1	2483.50	-0.64	31.17	30.53	54.00	-23.47	Average	237	214	P
2	2483.50	-0.64	45.47	44.83	74.00	-29.17	Peak	237	214	P
3	4960.00	8.61	30.55	39.16	54.00	-14.84	Average	258	161	P
4	4960.00	8.61	44.99	53.60	74.00	-20.40	Peak	258	161	P
5	7440.00	12.38	31.60	43.98	54.00	-10.02	Average	199	302	P
6	7440.00	12.38	45.06	57.44	74.00	-16.56	Peak	199	302	P

Note: Level=Reading+Factor
 Margin=Level-Limit
 Factor=Antenna Factor + cable loss - Amplifier Factor



Power	: AC 120V	Pol/Phase	: HORIZONTAL
Test Mode	: 8DPSK	Temperature	: 20 °C
Test Date	: Aug. 26, 2016	Humidity	: 63 %
Memo	: CH78	Atmospheric Pressure	: 1008 hPa

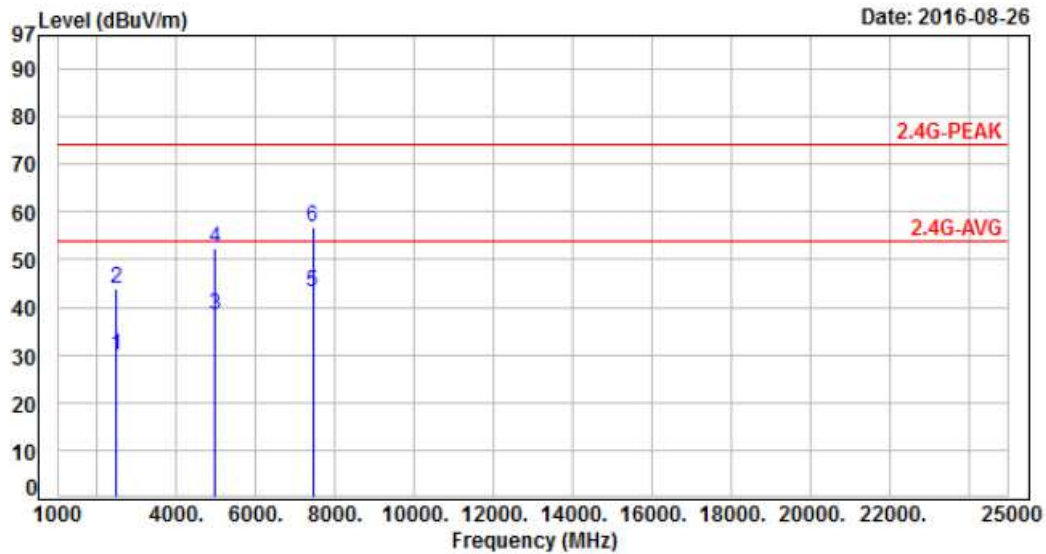

No.	Frequency (MHz)	Factor (dB)	Reading (dBuV)	Level (dBuV)	Limit (dBuV)	Margin (dB)	Detector	Height (cm)	Azimuth (deg)	P/F
1	2483.50	-0.64	30.44	29.80	54.00	-24.20	Average	278	256	P
2	2483.50	-0.64	44.37	43.73	74.00	-30.27	Peak	278	256	P
3	4960.00	8.61	29.61	38.22	54.00	-15.78	Average	189	212	P
4	4960.00	8.61	43.59	52.20	74.00	-21.80	Peak	189	212	P
5	7440.00	12.38	30.63	43.01	54.00	-10.99	Average	244	156	P
6	7440.00	12.38	44.40	56.78	74.00	-17.22	Peak	244	156	P

Note: Level=Reading+Factor
Margin=Level-Limit
Factor=Antenna Factor + cable loss - Amplifier Factor



6.7 Restricted Bands of Operation

Only spurious emissions are permitted in any of the frequency bands listed below:

MHz	MHz	MHz	GHz
0.09000 – 0.11000	16.42000 – 16.42300	399.9 – 410.0	4.500 – 5.250
0.49500 – 0.505**	16.69475 – 16.69525	608.0 – 614.0	5.350 – 5.460
2.17350 – 2.19050	16.80425 – 16.80475	960.0 – 1240.0	7.250 – 7.750
4.12500 – 4.12800	25.50000 – 25.67000	1300.0 – 1427.0	8.025 – 8.500
4.17725 – 4.17775	37.50000 – 38.25000	1435.0 – 1626.5	9.000 – 9.200
4.20725 – 4.20775	73.00000 – 74.60000	1645.5 – 1646.5	9.300 – 9.500
6.21500 – 6.21800	74.80000 – 75.20000	1660.0 – 1710.0	10.600 – 12.700
6.26775 – 6.26825	108.00000 – 121.94000	1718.8 – 1722.2	13.250 – 13.400
6.31175 – 6.31225	123.00000 – 138.00000	2200.0 – 2300.0	14.470 – 14.500
8.29100 – 8.29400	149.90000 – 150.05000	2310.0 – 2390.0	15.350 – 16.200
8.36200 – 8.36600	156.52475 – 156.52525	2483.5 – 2500.0	17.700 – 21.400
8.37625 – 8.38675	156.70000 – 156.90000	2655.0 – 2900.0	22.010 – 23.120
8.41425 – 8.41475	162.01250 – 167.17000	3260.0 – 3267.0	23.600 – 24.000
12.29000 – 12.29300	167.72000 – 173.20000	3332.0 – 3339.0	31.200 – 31.800
12.51975 – 12.52025	240.00000 – 285.00000	3345.8 – 3358.0	36.430 – 36.500
12.57675 – 12.57725	322.00000 – 335.40000	3600.0 – 4400.0	Above 38.6
13.36000 – 13.41000			

** : Until February 1, 1999, this restricted band shall be 0.490-0.510 MHz



7. Test of Conducted Spurious Emission

7.1 Test Limit

Below -20dB of the highest emission level of operating band (in 100kHz Resolution Bandwidth).

7.2 Test Procedure

- a. The transmitter output was connected to the spectrum analyzer via a low lose cable.
- b. Set both RBW and VBW of spectrum analyzer to 100 KHz with convenient frequency span including 100 KHz bandwidth from band edge.
- c. The band edges was measured and recorded.

7.3 Test Setup Layout

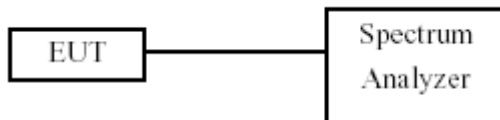

7.4 Test Result and Data

Test Date	: Sep. 12, 2016	Temperature	: 26°C
Atmospheric pressure	: 1025 hPa	Humidity	: 68%
Test Result	: PASS		

Note: Test plots refer to the following pages.



Modulation Type: GFSK, CH00

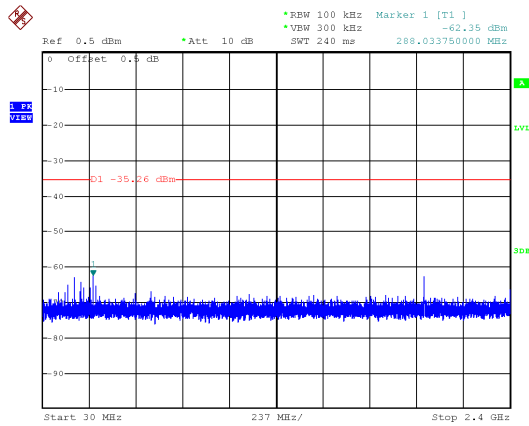

Modulation Type: GFSK, CH39

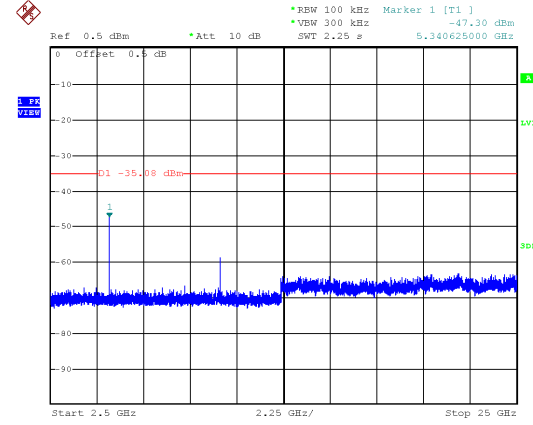
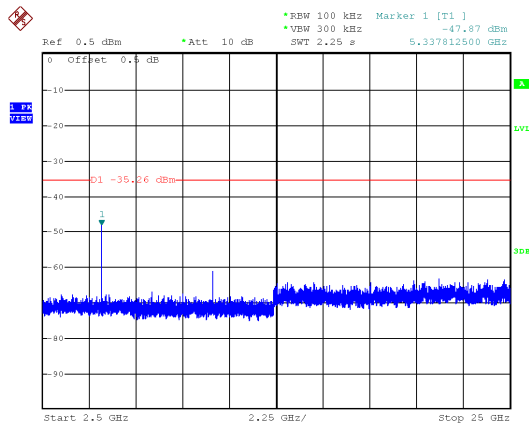
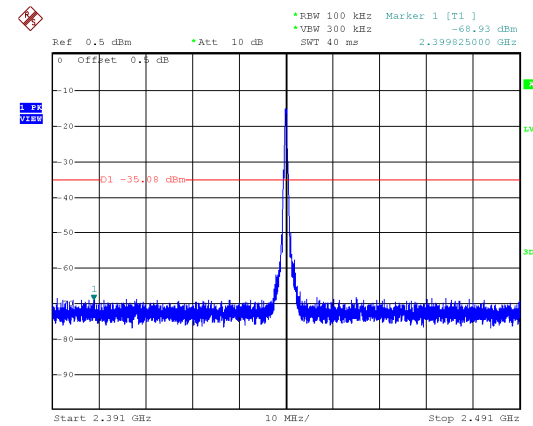
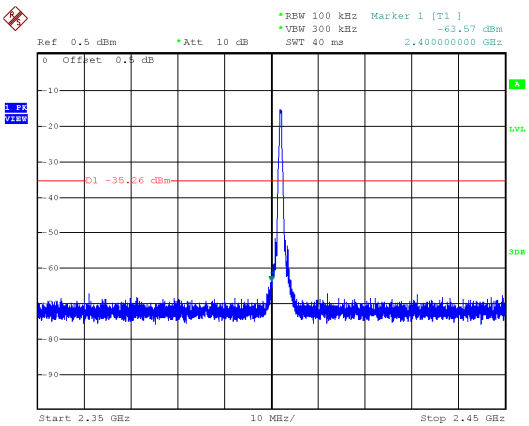
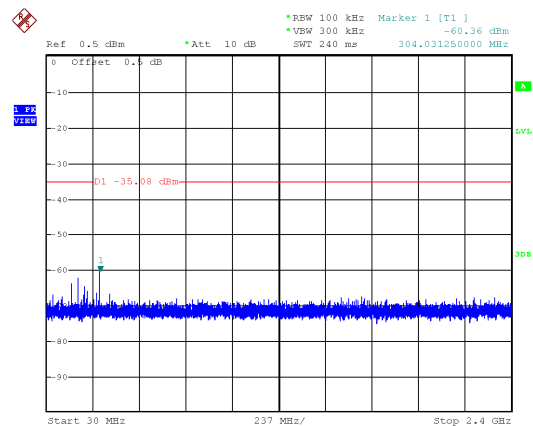



Modulation Type: GFSK, CH78

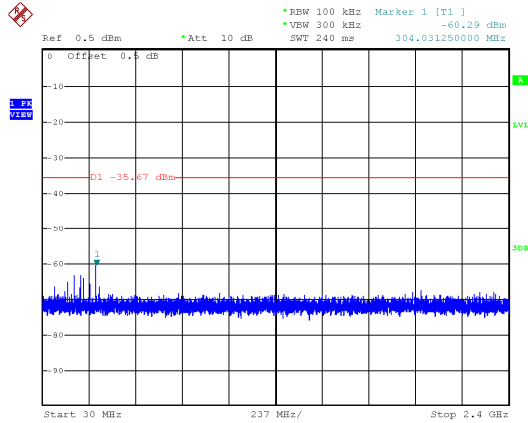

Modulation Type: $\pi/4$ -DQPSK, CH00

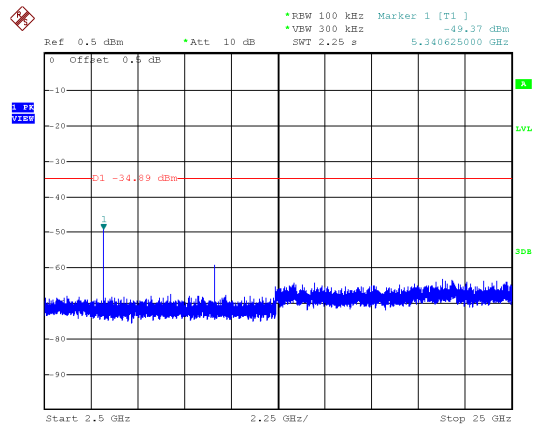
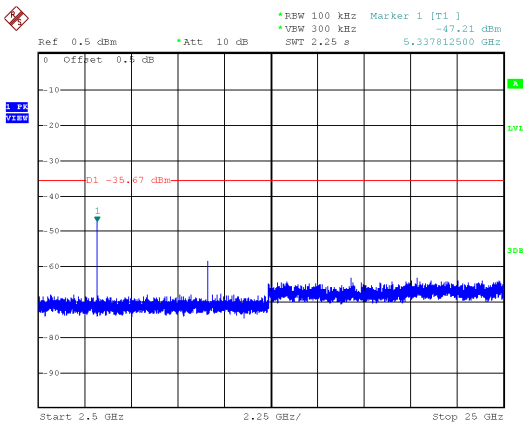
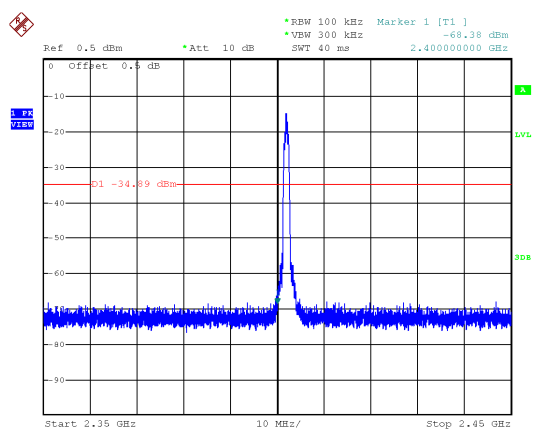
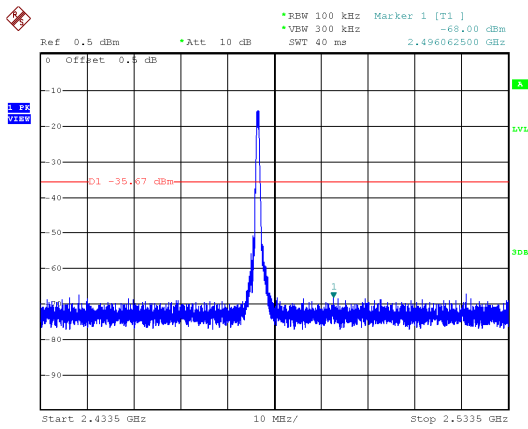
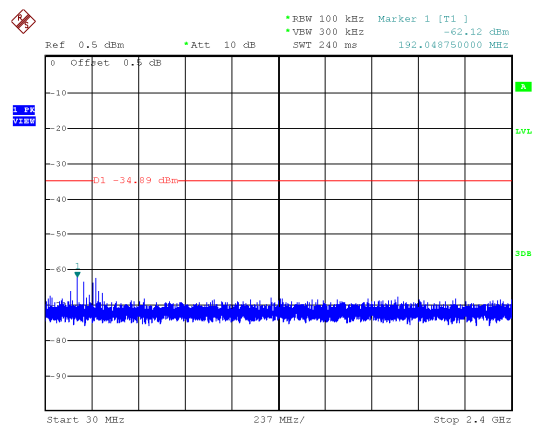



Modulation Type: $\pi/4$ -DQPSK, CH39

Modulation Type: $\pi/4$ -DQPSK, CH78

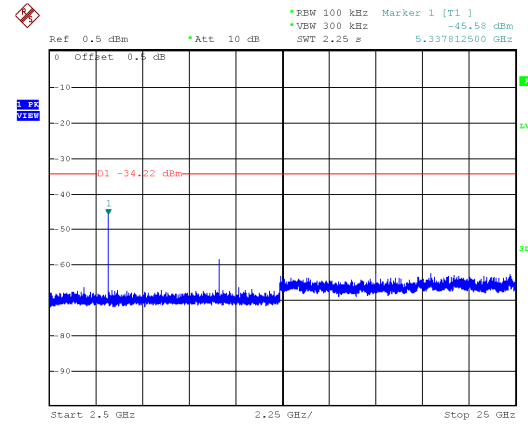
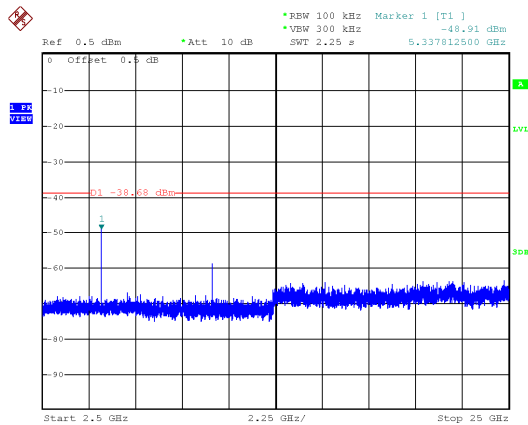
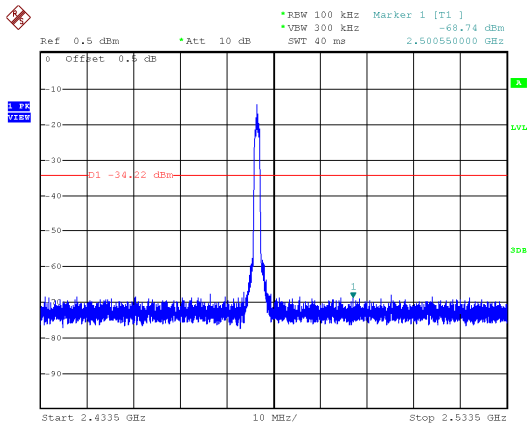
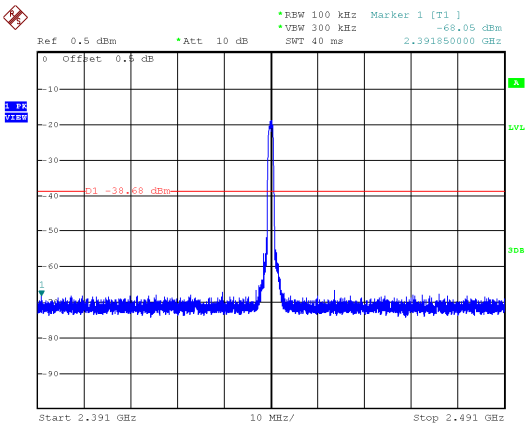
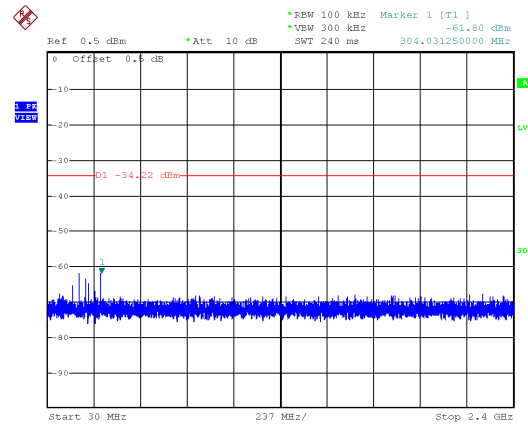
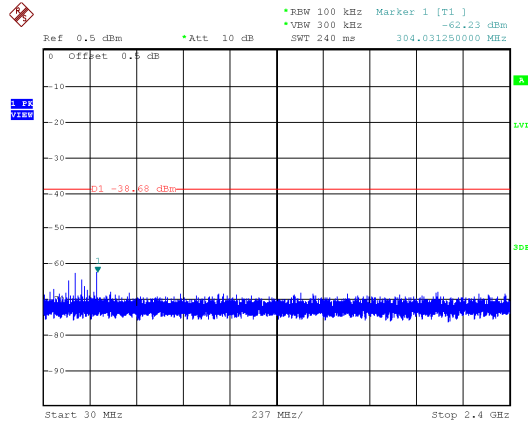



Modulation Type: 8DPSK, CH00

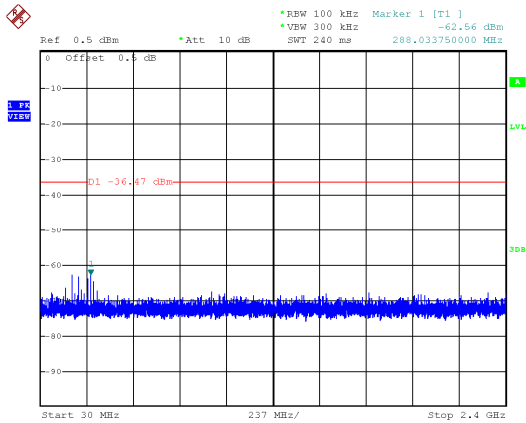

Modulation Type: 8DPSK, CH39

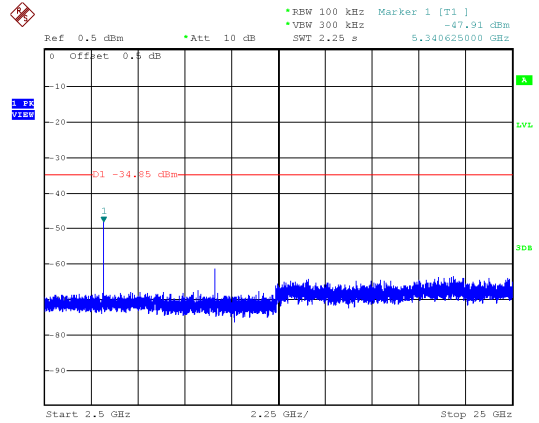
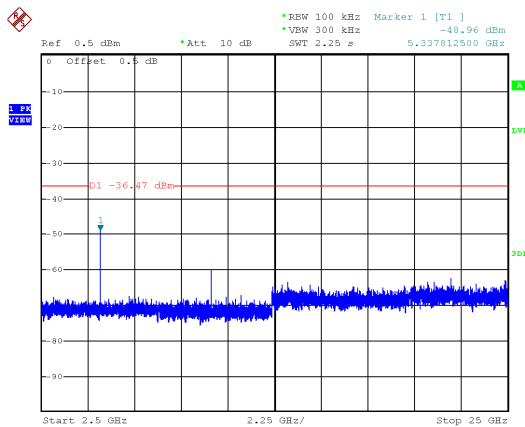
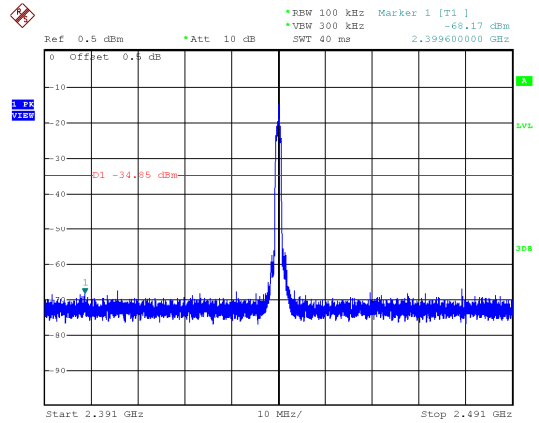
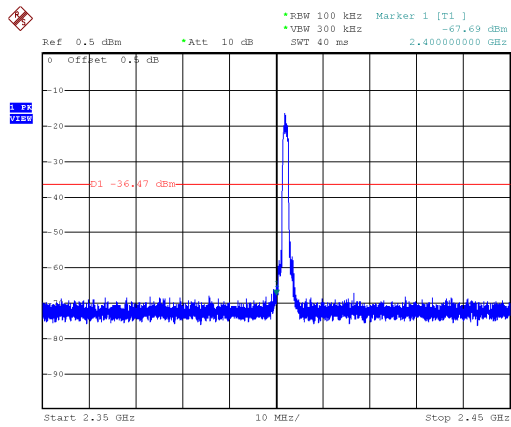
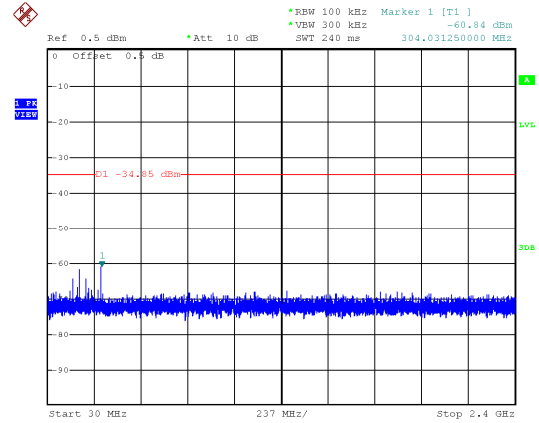



Modulation Type: 8DPSK, CH78

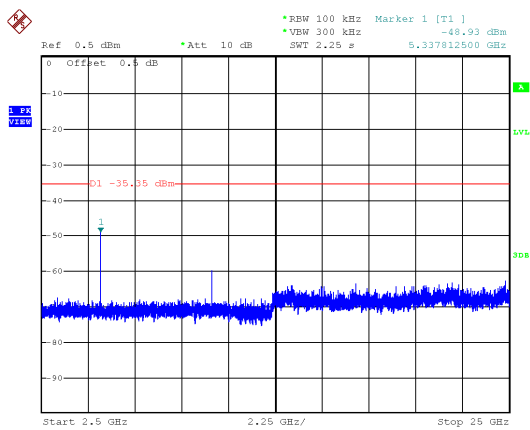
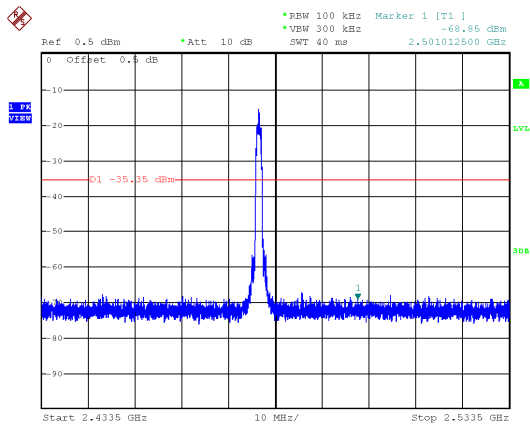
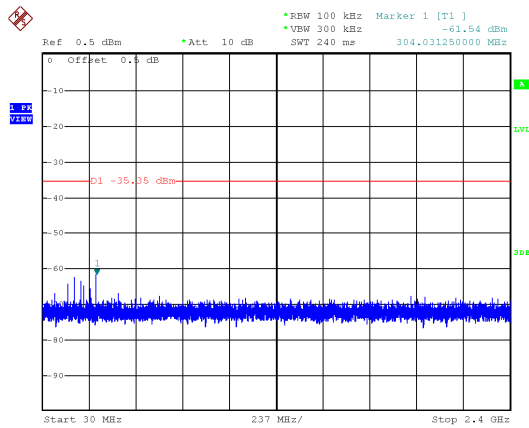



hopping mode:
Modulation Type: GFSK

Modulation Type: $\pi/4$ -DQPSK

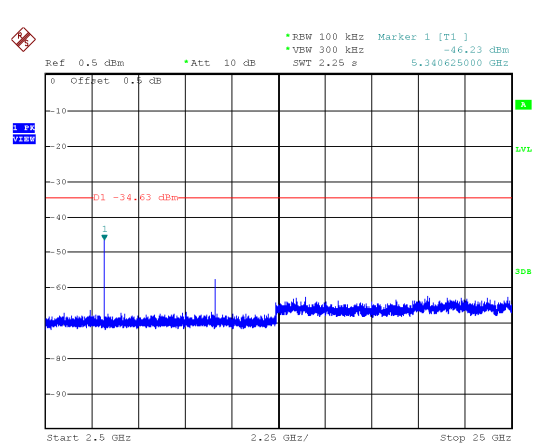
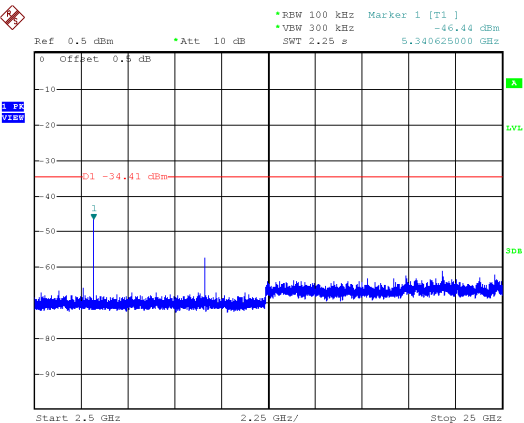
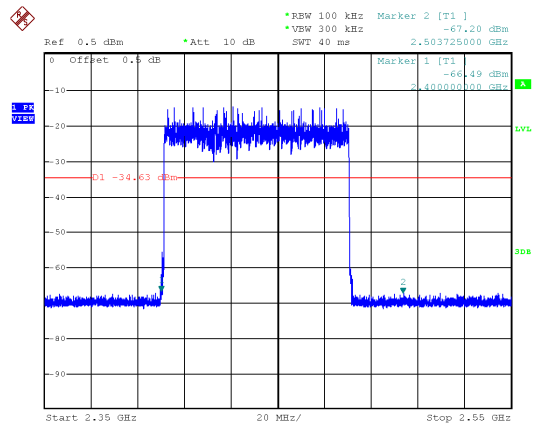
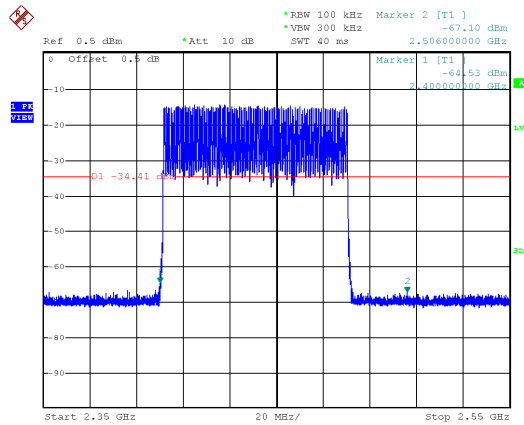
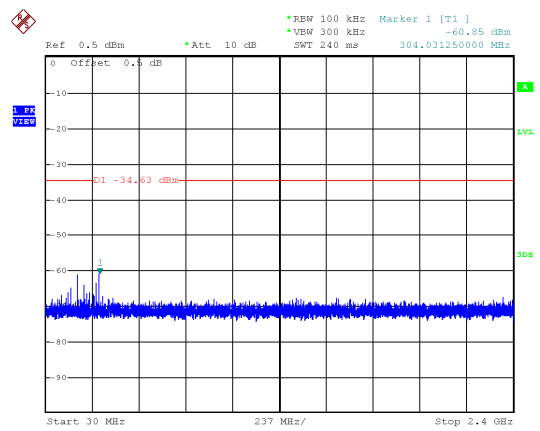
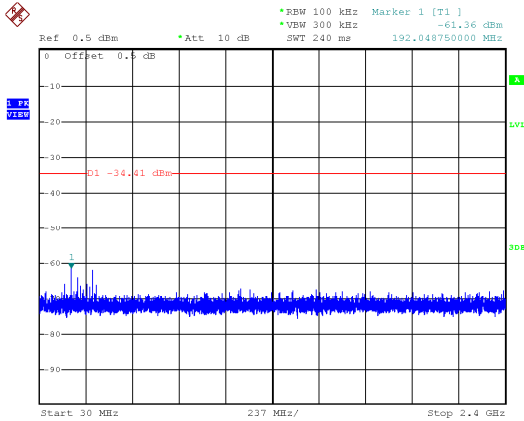



Modulation Type: 8DPSK

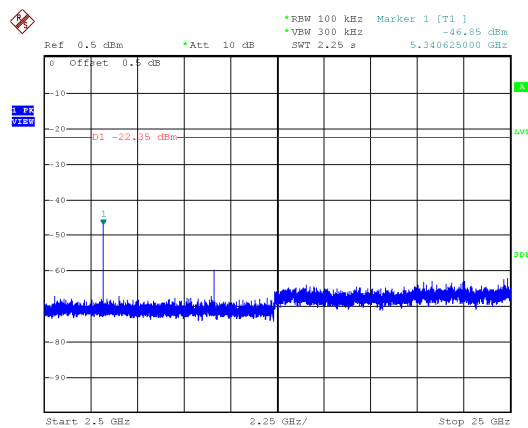
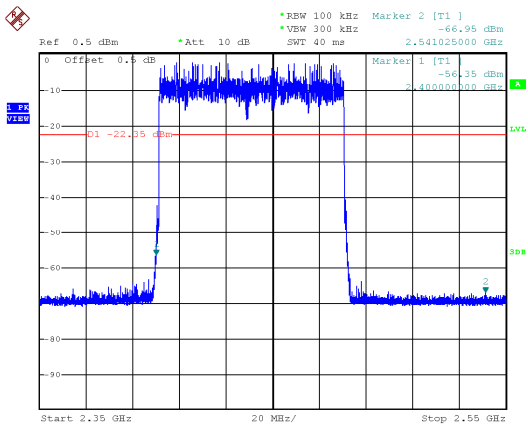
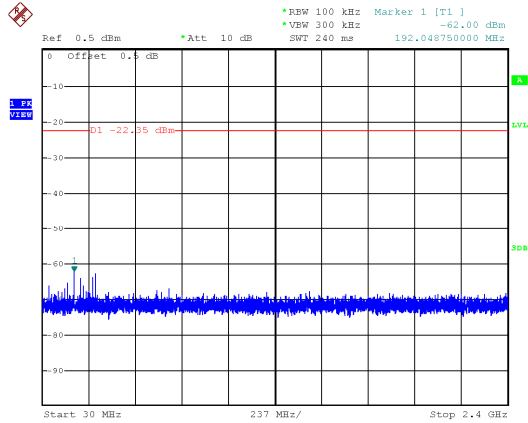



8. 20dB Bandwidth Measurement Data

8.1 Test Limit

Frequency hopping systems shall have hopping channel carrier frequencies separated by a minimum of 25 kHz or the 20 dB bandwidth of the hopping channel, whichever is greater. Alternatively, frequency hopping systems operating in the 2400–2483.5 MHz band may have hopping channel carrier frequencies that are separated by 25 kHz or two-thirds of the 20 dB bandwidth of the hopping channel, whichever is greater, provided the systems operate with an output power no greater than 125 mW.

8.2 Test Procedures

- a. The transmitter output was connected to the spectrum analyzer.
- b. Set RBW of spectrum analyzer to 30 KHz and VBW to 100 KHz.
- c. The 20 dB bandwidth is defined as the total spectrum the power of which is higher than peak power minus 20 dB.

8.3 Test Setup Layout

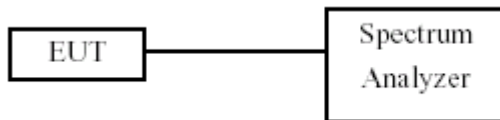

8.4 Test Result and Data

Test Date : Sep. 12, 2016 Temperature : 26°C
 Atmospheric pressure : 1025 hPa Humidity : 68%

Modulation Type	Channel	Frequency (MHz)	20dB Bandwidth (MHz)
GFSK	00	2402	0.824
	39	2441	0.872
	78	2480	0.880
$\pi/4$ -DQPSK	00	2402	1.212
	39	2441	1.224
	78	2480	1.224
8DPSK	00	2402	1.212
	39	2441	1.212
	78	2480	1.212



Modulation Type: GFSK
CH00

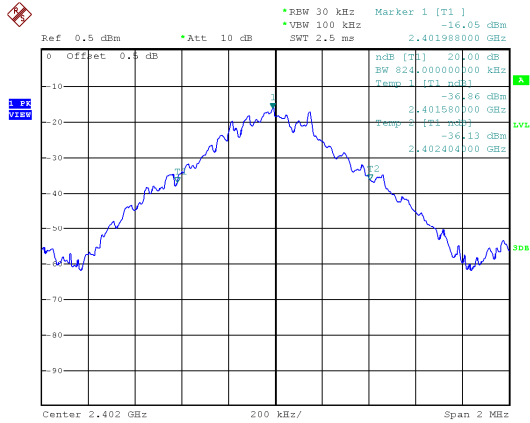

Modulation Type: $\pi/4$ -DQPSK
CH00

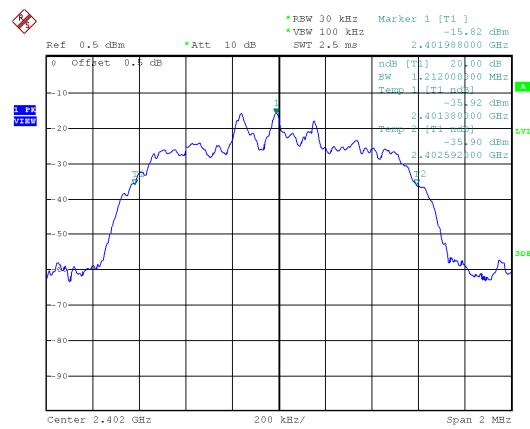

CH39

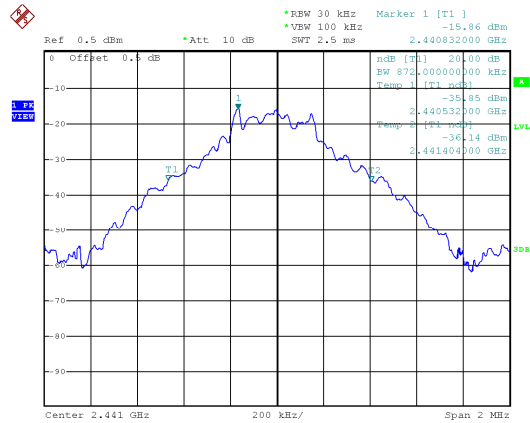

CH39

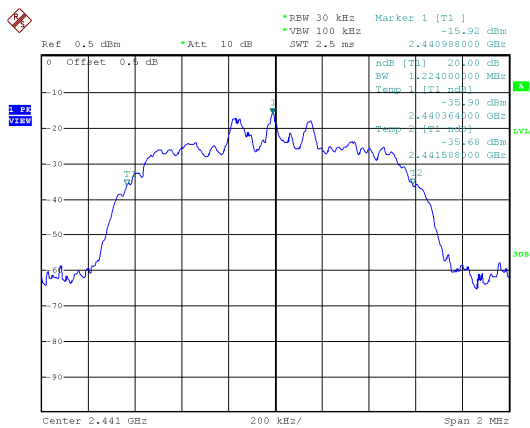

CH78

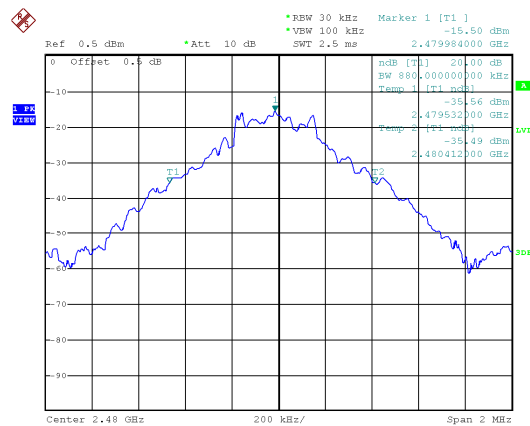

CH78

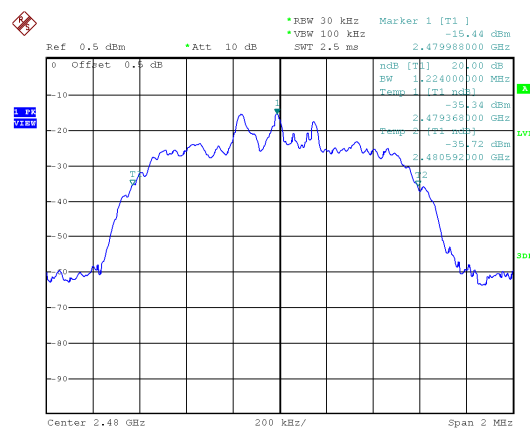



Modulation Type: 8DSPK CH00

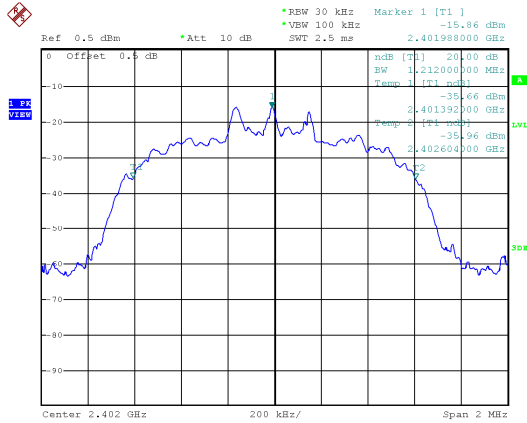

CH39

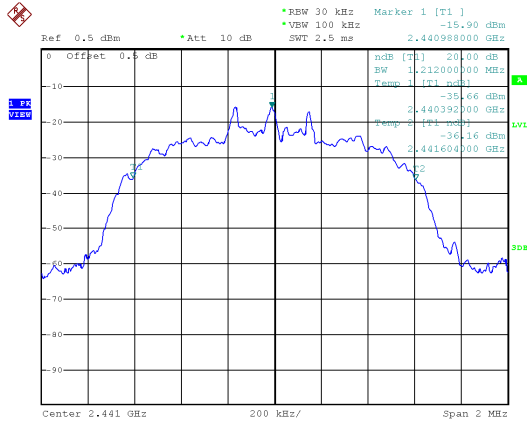

CH78

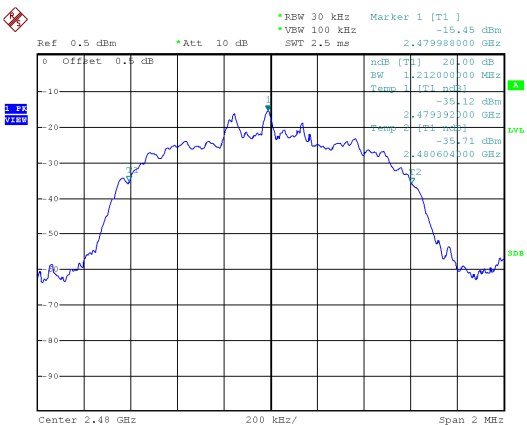



9. Frequencies Separation

9.1 Test Limit

Frequency hopping systems shall have hopping channel carrier frequencies separated by a minimum of 25 kHz or the 20 dB bandwidth of the hopping channel, whichever is greater.

9.2 Test Procedures

- a. The transmitter output was connected to the spectrum analyzer.
- b. Set RBW of spectrum analyzer to 30 KHz and VBW to 100 KHz.
- c. By using the MaxHold function record the separation of two adjacent channels.
- d. Measure the frequency difference of these two adjacent channels.

9.3 Test Setup Layout

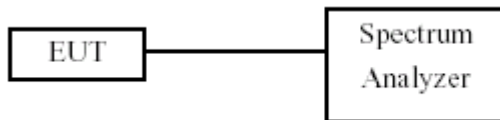

9.4 Test Result and Data

Test Date : Sep. 12, 2016 Temperature : 26°C
Atmospheric pressure : 1025 hPa Humidity : 68%

Modulation Type	Channel	Frequency (MHz)	Channel Separation (MHz)
GFSK	00	2402	0.98
	39	2441	1.00
	78	2480	1.01
$\pi/4$ -DQPSK	00	2402	1.00
	39	2441	1.05
	78	2480	1.00
8DPSK	00	2402	1.00
	39	2441	1.01
	78	2480	1.01



Modulation Type: GFSK
CH00

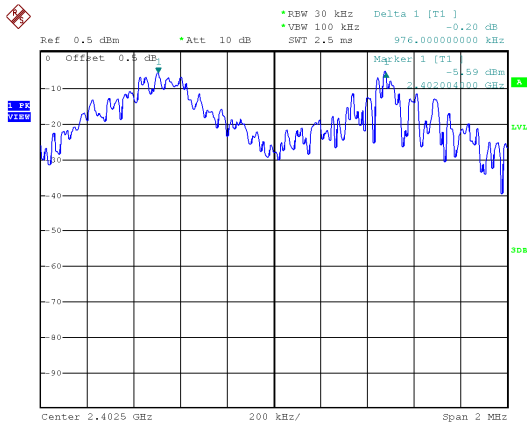

Modulation Type: $\pi/4$ -DQPSK
CH00

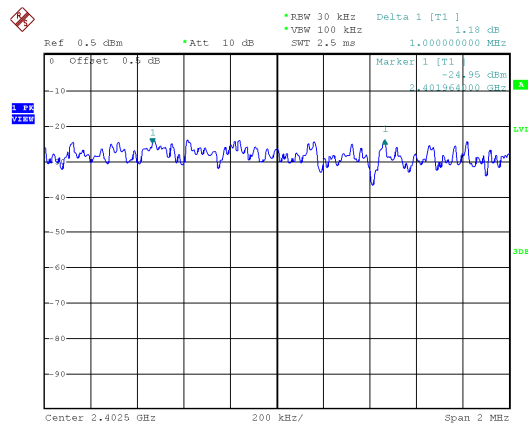

CH39

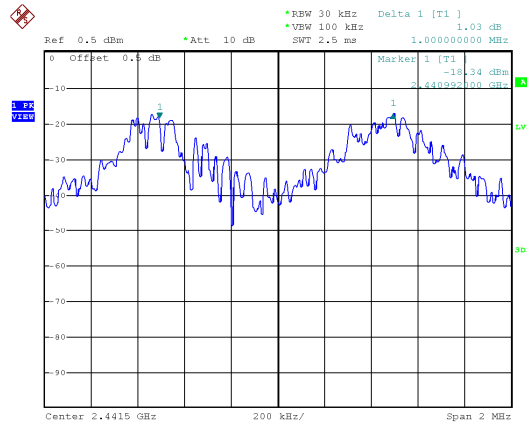

CH39

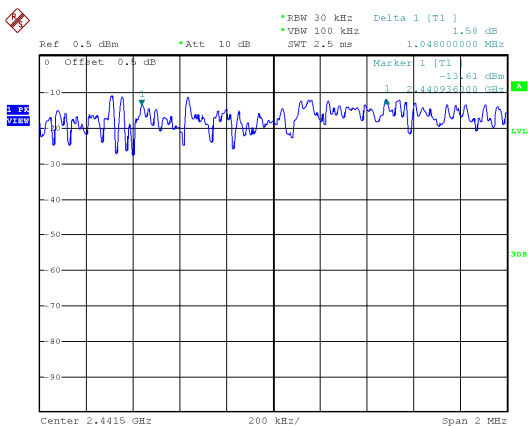

CH78

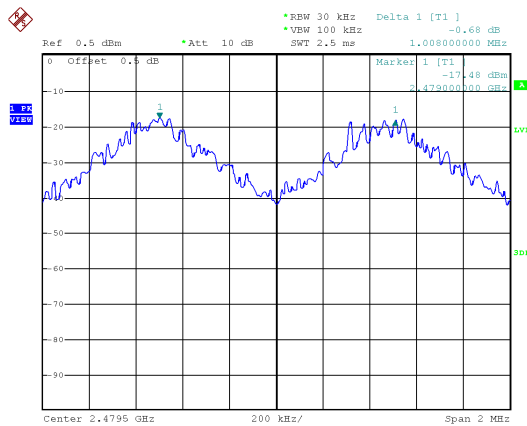

CH78

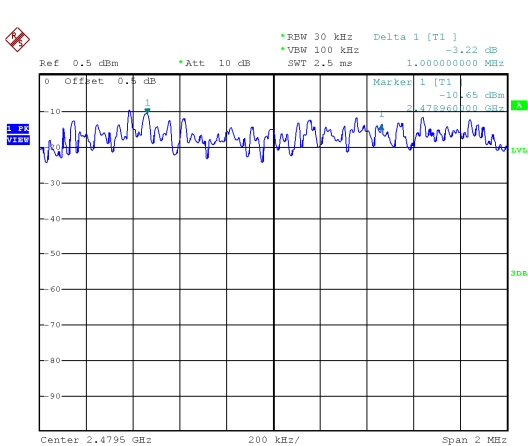



Modulation Type: 8DSPK
CH00

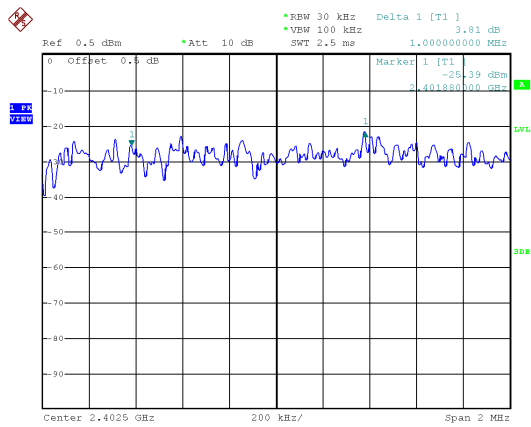

CH39

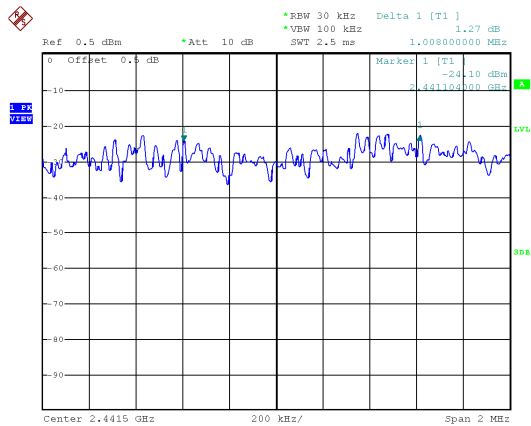

CH78

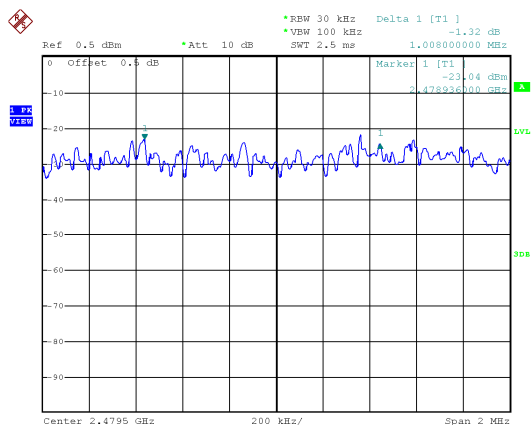



10. Dwell Time on each channel

10.1 Test Limit

The average time of occupancy on any channel shall not be greater than 0.4 seconds within a period of 0.4 seconds multiplied by the number of hopping channels employed.

10.2 Test Procedures

1. The transmitter output was connected to the spectrum analyzer.
2. Adjust the center frequency to measure frequency, then set zero span mode.
2. Set RBW of spectrum analyzer to 1 MHz and VBW to 1 MHz.
4. Measure the time duration of one transmission on the measured frequency.

10.3 Test Setup Layout

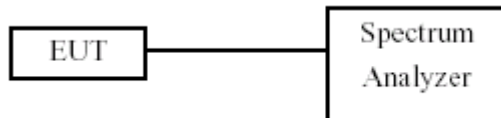

10.4 Test Result and Data

Test Date : Sep. 12, 2016 Temperature : 26°C
 Atmospheric pressure : 1025 hPa Humidity : 68%
 Test Period = 0.4 (second/ channel) x 79 Channel = 31.6 sec

Modulation Type	Frequency (MHz)	Length of transmission time (ms)	Number of transmission in a 31.6 (79 Hopping*0.4)	Dwell Time (ms)	Limit (ms)
GFSK (DH1)	2402	0.420	320.10	134.44	400
GFSK (DH3)	2402	1.690	159.90	270.23	400
GFSK (DH5)	2402	2.960	106.81	316.16	400
$\pi/4$ -DQPSK (DH1)	2402	0.428	320.10	137.00	400
$\pi/4$ -DQPSK (DH3)	2402	1.700	159.90	271.83	400
$\pi/4$ -DQPSK (DH5)	2402	3.040	106.81	324.70	400
8DPSK (DH1)	2402	0.432	320.10	138.28	400
8DPSK (DH3)	2402	1.700	159.90	271.83	400
8DPSK (DH5)	2402	2.960	106.81	316.16	400



Modulation Type: GFSK(DH1)

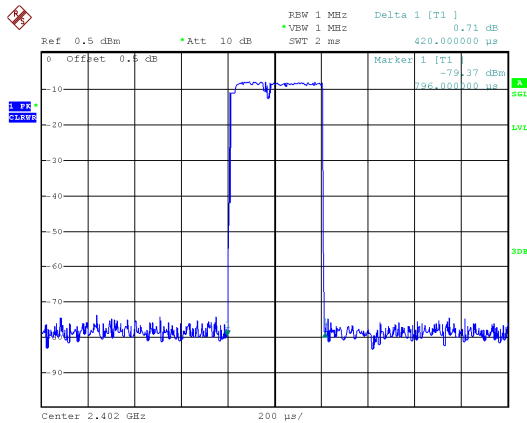

Date: 24.AUG.2016 17:33:05

Modulation Type: $\pi/4$ -DQPSK (DH1)

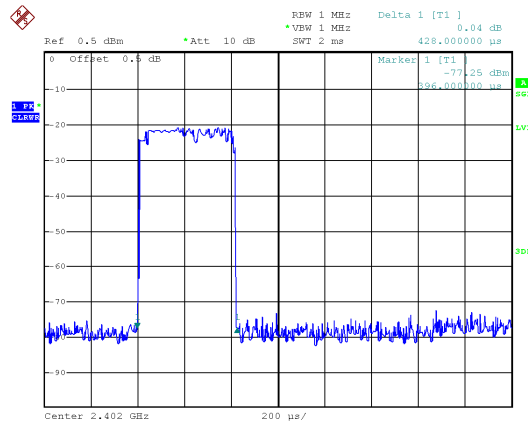

Date: 24.AUG.2016 17:34:58

Modulation Type: GFSK(DH3)

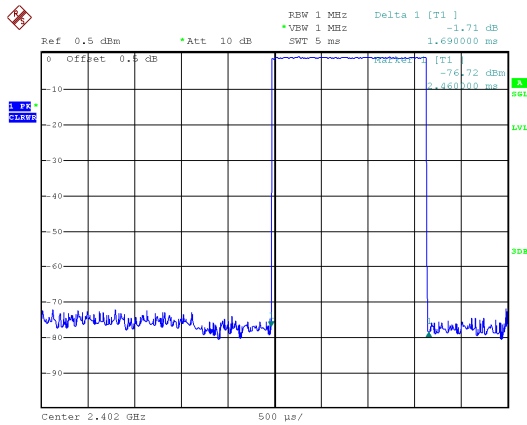

Date: 24.AUG.2016 17:32:16

Modulation Type: $\pi/4$ -DQPSK (DH3)

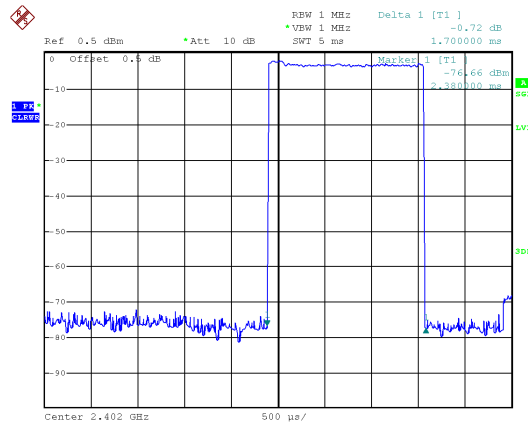

Date: 24.AUG.2016 17:36:20

Modulation Type: GFSK(DH5)

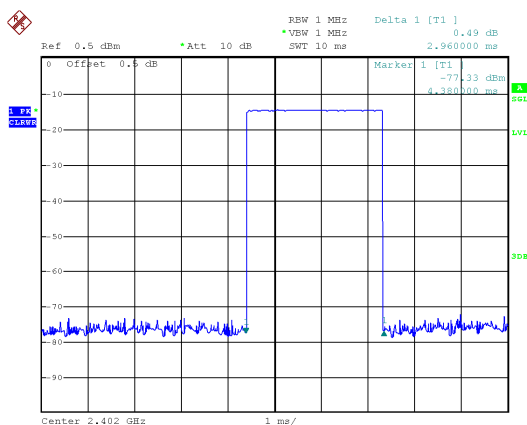

Date: 24.AUG.2016 17:31:25

Modulation Type: $\pi/4$ -DQPSK (DH5)

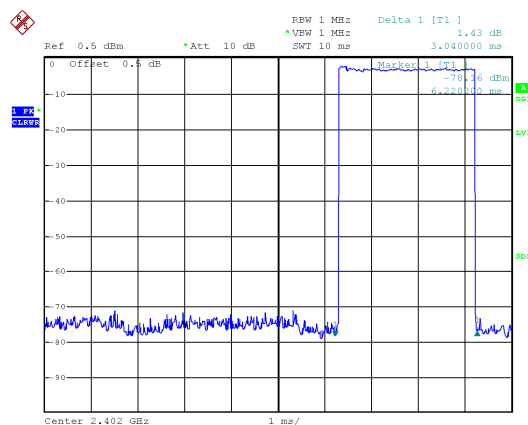

Date: 24.AUG.2016 17:37:12



Modulation Type: 8DSPK (DH1)

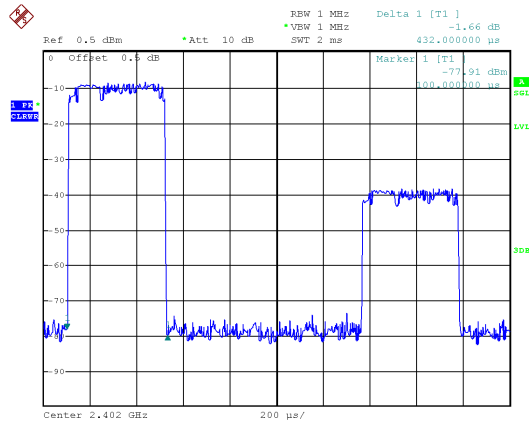

Date: 24.AUG.2016 17:43:33

Modulation Type: 8DSPK (DH3)

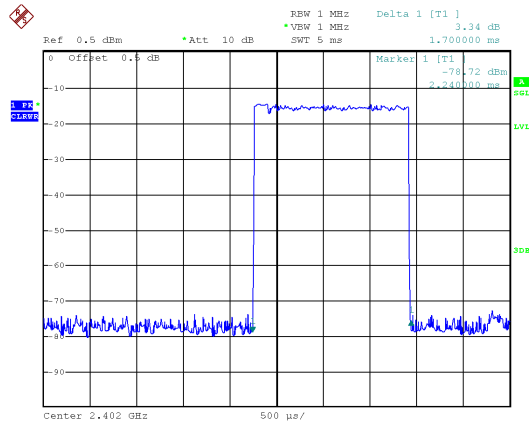

Date: 24.AUG.2016 17:41:49

Modulation Type: 8DSPK (DH5)

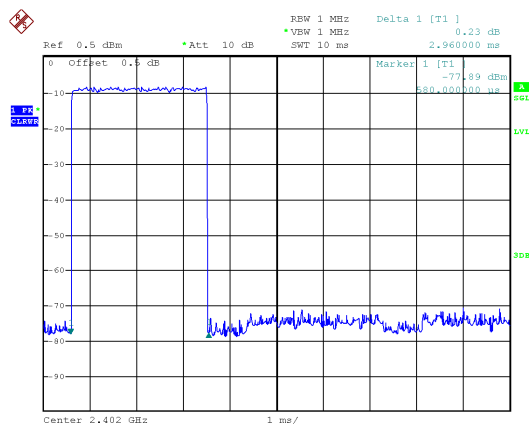

Date: 24.AUG.2016 17:39:39



11. Number of Hopping Channels

11.1 Test Limit

Frequency hopping systems in the 2400 ~ 2483.5 MHz band shall use at least 15 channels.

11.2 Test Procedures

- a. The transmitter output was connected to the spectrum analyzer.
- b. 2. Set RBW of spectrum analyzer to 100 KHz and VBW to 100 KHz.
- c. 3. Set the MaxHold function, and then keep the EUT in hopping mode. Record all the signals from each channel until each one has been record.

11.3 Test Setup Layout

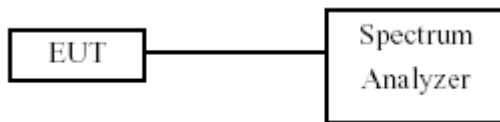

11.4 Test Result and Data

Test Date : Sep. 12, 2016 Temperature : 26°C
Atmospheric pressure : 1025 hPa Humidity : 68%

Modulation Type	Hopping Channels
GFSK	79
$\pi/4$ -DQPSK	79
8DPSK	79



Modulation Type: GFSK

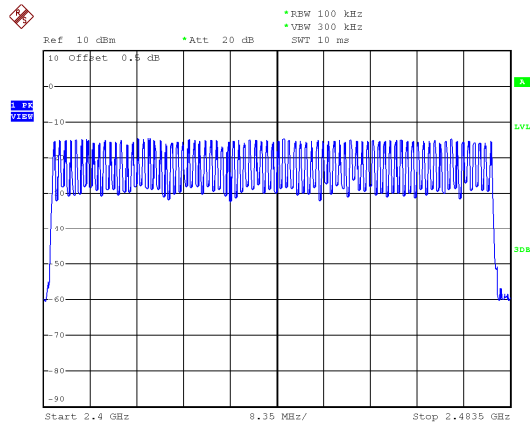

Modulation Type: $\pi/4$ -DQPSK

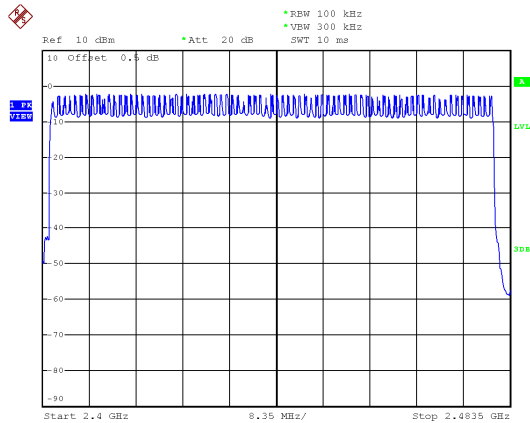

Modulation Type: 8DPSK

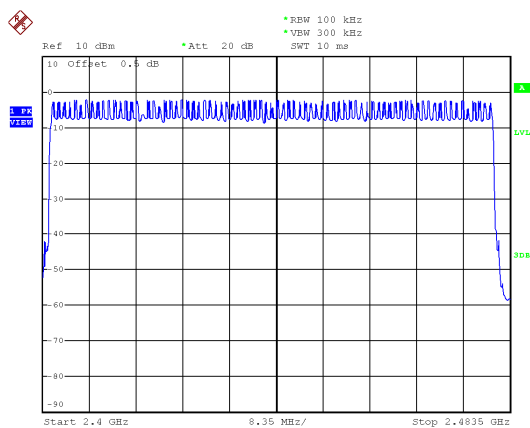



12. Maximum Peak Output Power

12.1 Test Limit

The Maximum Peak Output Power Measurement is 30dBm.

12.2 Test Procedures

The antenna port(RF output)of the EUT was connected to the input(RF input)of a power meter. Power was read directly from the meter and cable loss connection was added to the reading to obtain power at the EUT antenna terminal. The EUT Output Power was set to maximum to produce the worse case test result.

12.3 Test Setup Layout

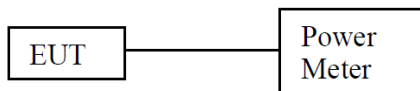



12.4 Test Result and Data

Test Date : Sep. 12, 2016 Temperature : 26°C
Atmospheric pressure : 1025 hPa Humidity : 68%

Modulation Type	Channel	Frequency (MHz)	Peak Output Power (dBm)	Peak Output Power (mW)
GFSK	00	2402	-13.88	0.041
	39	2441	-13.84	0.041
	78	2480	-13.37	0.046
$\pi/4$ -DQPSK	00	2402	-13.98	0.040
	39	2441	-13.99	0.040
	78	2480	-13.53	0.044
8DPSK	00	2402	-13.72	0.042
	39	2441	-13.68	0.043
	78	2480	-13.78	0.042

Modulation Type	Channel	Frequency (MHz)	Average Output Power (dBm)	Average Output Power (mW)
GFSK	00	2402	-14.75	0.033
	39	2441	-14.68	0.034
	78	2480	-14.18	0.038
$\pi/4$ -DQPSK	00	2402	-16.60	0.022
	39	2441	-16.61	0.022
	78	2480	-16.12	0.024
8DPSK	00	2402	-16.65	0.022
	39	2441	-16.75	0.021
	78	2480	-16.85	0.021