

FCC Test Report

Product Name : TPMS
Trade name : MOBILETRON
Model No. : TX-T001, MX002A, TX-T002, MX002R
FCC ID. : ULZ-MX002

Applicant : Mobiletron Electronics Co., Ltd.
Address : 85, Sec. 4, Chung-Ching Rd., Ta-Ya District,
Taichung City 428, Taiwan (R.O.C.)

Date of Receipt : Nov. 22, 2018
Issued Date : Jan. 08, 2019
Report No. : 18B0365R-RFUSP14V00
Report Version : V1.0



The declaration results relate only to the samples calculated.
The declaration shall not be reproduced except in full without the written approval of DEKRA Testing and Certification Co., Ltd.

Test Report Certification

Issued Date : Jan. 08, 2019

Report No. : 18B0365R-RFUSP14V00



Product Name : TPMS
 Applicant : Mobiletron Electronics Co., Ltd.
 Address : 85, Sec. 4, Chung-Ching Rd., Ta-Ya District, Taichung City
 428, Taiwan (R.O.C.)
 Manufacturer : Mobiletron Electronics Co., Ltd.
 Model No. : TX-T001, MX002A, TX-T002, MX002R
 Trade Name : MOBILETRON
 FCC ID. : ULZ-MX002
 EUT Voltage : DC 3V (Power by Battery)
 Testing Voltage : DC 3V (Power by Battery)
 Applicable Standard : FCC 15 Subpart C Section 15.231(b): 2017
 Laboratory Name : Hsin Chu Laboratory
 Address : No.372-2, Sec. 4, Zhongxing Rd., Zhudong Township,
 Hsinchu County 310, Taiwan, R.O.C.
 TEL: +886-3-582-8001 / FAX: +886-3-582-8958
 Test Result : Complied

Documented By : 

 (Demi Chang / Senior Engineering Adm. Specialist)

Tested By : 

 (Mark Chang/ Engineer)

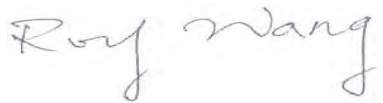
Approved By : 

 (Roy Wang / Director)

Revision History

Report No.	Version	Description	Issued Date
18B0365R-RFUSP14V00	V1.0	Initial issue of report.	Jan. 08, 2019

TABLE OF CONTENTS

Description	Page
1. General Information.....	5
1.1. EUT Description	5
1.2. Test Mode	6
1.3. Tested System Details	7
1.4. Configuration of tested System	7
1.5. EUT Exercise Software	7
1.6. Test Facility	8
1.7. List of Test Equipment	9
1.8. Measurement Uncertainty	10
2. Conducted Emission.....	11
2.1. Test Setup	11
2.2. Limits	11
2.3. Test Procedure	12
2.4. Test Specification.....	12
2.5. Uncertainty	12
2.6. Test Result.....	12
3. Radiated Emission.....	13
3.1. Test Setup	13
3.2. Limits	14
3.3. Test Procedure	15
3.4. Test Specification.....	15
3.5. Test Result.....	16
4. Occupied Bandwidth.....	30
4.1. Test Setup	30
4.2. Limits	30
4.3. Test Specification.....	30
4.4. Test Result.....	31
5. Transmitter time.....	33
5.1. Test Setup	33
5.2. Limits	33
5.3. Test Specification.....	33
5.4. Test Result.....	34
Attachment 1.....	38
Test Setup Photograph.....	38
Attachment 2.....	40
EUT External Photograph.....	40
Attachment 3.....	45
EUT Internal Photograph.....	45

1. General Information

1.1. EUT Description

Product Name	TPMS
Trade Name	MOBILETRON
Model No.	TX-T001, MX002A, TX-T002, MX002R
Frequency Range	315 MHz
Channel Number	1
Type of Modulation	FSK/ASK

Antenna Information	
MFR. / Model	MOBILETRON / 20010458
Antenna Type	LOOP ANTENNA
Antenna Gain	-10 dBi

Accessories Information	
Schrader valve	2PCS White (Metal) for Model No.: TX-T001, MX002A Black (Plastic) for Model No.: TX-T002, MX002R

Working Frequency of Each Channel	
Channel	Frequency
01	315 MHz

Note:

1. This device is a TPMS including 315 MHz and 433.92MHz transmitting functions.
2. The different of the each model is shown as below:

Model No.	Different
TX-T001	All models are identical in electrical design. The different is appearance design for marketing purpose.
MX002A	
TX-T002	
MX002R	

3. These tests are conducted on a sample for the purpose of demonstrating compliance with Part 15 Subpart C Paragraph 15.231.
4. The radiation measurements are performed in X, Y, Z axis positioning. Only the worst case is shown in the report.

1.2. Test Mode

DEKRA verified the construction and function in typical operation. All the test modes are performed in normal operation and are defined as:

Test Mode	Mode 1: Transmit_315MHz_FSK Mode 2: Transmit_315MHz_ASK
-----------	--

Performed Item	Mode 1	Mode 2
Conducted Emission	No	No
Radiated Emission	Yes	Yes
Occupied Bandwidth	Yes	Yes
Transmitter time	Yes	Yes

1.3. Tested System Details

The types for all equipment, plus descriptions of all cables used in the tested system (including inserted cards) are:

Product	Manufacturer	Model No.	Serial No.	Power Cord
N/A				

1.4. Configuration of tested System

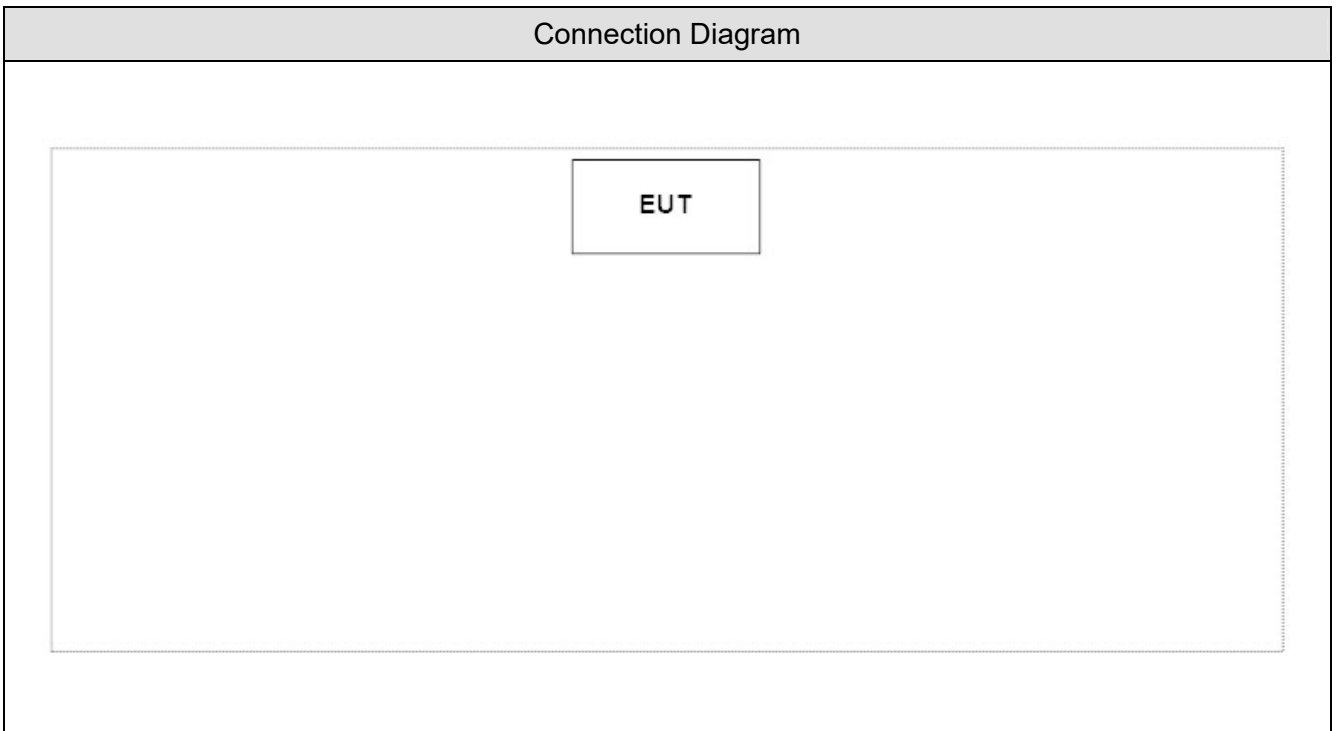

1.5. EUT Exercise Software

1	Setup the EUT as shown in Section 1.4.
2	Confirm that the signal is correct.
3	Verify that the EUT works properly.

1.6. Test Facility

Ambient conditions in the laboratory:

Items	Test Item	Required (IEC 68-1)	Actual	Test Site
Temperature (°C)	FCC PART 15C 15.231(b) Conducted Emission	15 - 35	20°C	--
Humidity (%RH)		25 - 75	50%RH	
Barometric pressure (mbar)		860 - 1060	950-1000	
Temperature (°C)	FCC PART 15C 15.231(b) Radiated Emission	15 - 35	25°C	2
Humidity (%RH)		25 - 75	45%RH	
Barometric pressure (mbar)		860 - 1060	950-1000	
Temperature (°C)	FCC PART 15C 15.231(b) Occupied Bandwidth	15 - 35	25°C	3
Humidity (%RH)		25 - 75	65%RH	
Barometric pressure (mbar)		860 - 1060	950-1000	
Temperature (°C)	FCC PART 15C 15.231(b) Transmitter time	15 - 35	25°C	3
Humidity (%RH)		25 - 75	48%RH	
Barometric pressure (mbar)		860 - 1060	950-1000	

Note: Test Site information refers to Laboratory Information.

Laboratory Information

The related certificate for our laboratories about the test site and management system can be downloaded from DEKRA Testing and Certification Co., Ltd. Web Site:

<http://www.dekra.com.tw/english/about/certificates.aspx?bval=5>

The address and introduction of DEKRA Testing and Certification Co., Ltd. laboratories can be founded in our Web site: http://www.dekra.com.tw/index_en.aspx

If you have any comments, Please don't hesitate to contact us. Our test sites as below:

- No. 75-2, 3rd Lin, WangYe Keng, Yonghxing Tsuen, Qionglin Shiang, Hsinchu County 307, Taiwan (R.O.C.)
TEL: +886-3-592-8858 / FAX: +886-3-592-8859 E-Mail : info.tw@dekra.com
- No.372, Sec. 4, Zhongxing Rd., Zhudong Township, Hsinchu County 31061, Taiwan
TEL: +886-3-582-8001 / FAX: +886-3-582-8958 E-Mail : info.tw@dekra.com
- No.372-2, Sec. 4, Zhongxing Rd., Zhudong Township, Hsinchu County 31061, Taiwan
TEL: +886-3-582-8001 / FAX: +886-3-582-8958 E-Mail : info.tw@dekra.com

1.7. List of Test Equipment

Radiated Emission / CB2-H, CB4-H

Instrument	Manufacturer	Model No.	Serial No.	Cal. Date	Next Cal. Date
Signal Analyzer	R&S	FSVA40	101455	2018/11/05	2019/11/04
Signal & Spectrum Analyzer	R&S	FSV40	101049	2018/01/10	2019/01/09
EXA Signal Analyzer	Keysight	N9010A	MY51440132	2018/03/05	2019/03/04
Bilog Antenna	Teseq	CBL6112D	23191	2018/06/26	2019/06/25
Horn Antenna	Schwarzbeck	BBHA 9120D	639	2018/06/01	2019/05/31
Horn Antenna	Schwarzbeck	BBHA 9170	202	2018/01/31	2019/01/30
Pre-Amplifier	Dekra	AP-025C	201801236	2018/02/26	2019/02/25
Pre-Amplifier	EMCI	EMC11830I	980366	2018/01/08	2019/01/07
Pre-Amplifier	Dekra	AP-400C	201801231	2018/12/05	2019/12/04
Horn Antenna	Schwarzbeck	BBHA 9120D	01656	2018/10/17	2019/10/16
Band Reject Filter	Micro-Tronics	BRM50702	G192	2018/04/11	2019/04/10
Signal Analyzer	R&S	FSV40	101435	2018/07/19	2019/07/18
Coaxial Cable	Huber+Suhner	SF104_SF104_ SF104_SF104(16.0m)	CB2-H	2018/08/21	2019/08/20
Coaxial Cable	Suhner	SF104_SF106_ SF104_SF102(23.5m)	CB4_1	2018/08/21	2019/08/20

Occupied Bandwidth / SR10-H

Instrument	Manufacturer	Model No.	Serial No.	Cal. Date	Next Cal. Date
Spectrum Analyzer	Keysight	N9030B	MY57140404	2018/06/26	2019/06/25
Spectrum Analyzer	Keysight	N9010B	MY57110159	2018/05/25	2019/05/24
Spectrum Analyzer	Agilent	N9010A	US47140172	2018/07/18	2019/07/17
Signal & Spectrum Analyzer	R&S	FSV40	101049	2018/01/10	2019/01/09

Transmitter time / SR10-H

Instrument	Manufacturer	Model No.	Serial No.	Cal. Date	Next Cal. Date
Spectrum Analyzer	Keysight	N9030B	MY57140404	2018/06/26	2019/06/25
Spectrum Analyzer	Keysight	N9010B	MY57110159	2018/05/25	2019/05/24
Spectrum Analyzer	Agilent	N9010A	US47140172	2018/07/18	2019/07/17
Signal & Spectrum Analyzer	R&S	FSV40	101049	2018/01/10	2019/01/09

1.8. Measurement Uncertainty

Test Item	Uncertainty
Radiated Emission (30MHz~1GHz)	± 3.8 dB below 1GHz
Radiated Emission (1GHz~26.5GHz)	± 3.9 dB above 1GHz
Occupied Bandwidth	± 150 Hz
Transmitter time	± 25 msec

2. Conducted Emission

2.1. Test Setup

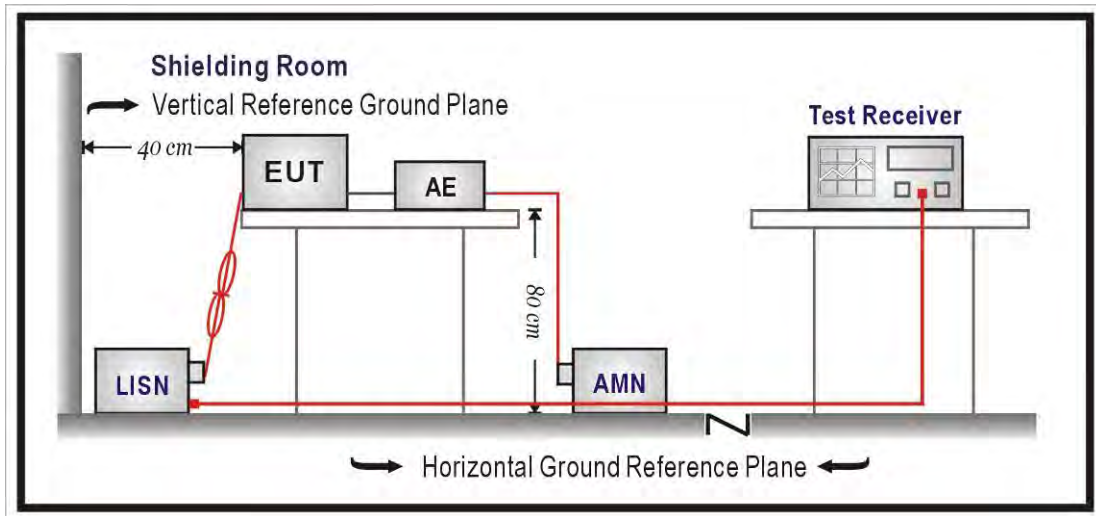

2.2. Limits

FCC Part 15 Subpart C Paragraph 15.207 Limits (dBuV)		
Frequency (MHz)	QP	AV
0.15 - 0.50	66 - 56	56 - 46
0.50 - 5.0	56	46
5.0 - 30	60	50

Remarks: In the above table, the tighter limit applies at the band edges.

2.3. Test Procedure

The EUT was setup according to ANSI C63.10: 2013 and tested according to DTS test procedure of KDB558074 for compliance to FCC 47CFR 15.247 requirements.

The EUT was placed on a platform of nominal size, 1 m by 1.5 m, raised 80 cm above the conducting ground plane. The vertical conducting plane was located 40 cm to the rear of the EUT. All other surfaces of EUT were at least 80 cm from any other grounded conducting surface. The EUT and simulators are connected to the main power through a line impedance stabilization network (LISN). The LISN provides a 50 ohm /50uH coupling impedance for the measuring equipment. The peripheral devices are also connected to the main power through a LISN. (Please refer to the block diagram of the test setup and photographs.)

Each current-carrying conductor of the EUT power cord, except the ground (safety) conductor, was individually connected through a LISN to the input power source.

The excess length of the power cord between the EUT and the LISN receptacle were folded back and forth at the center of the lead to form a bundle not exceeding 40 cm in length.

Conducted emissions were investigated over the frequency range from 0.15MHz to 30MHz using a receiver bandwidth of 9 kHz.

2.4. Test Specification

According to FCC Part 15 Subpart C Paragraph 15.207: 2017

2.5. Uncertainty

The measurement uncertainty is defined as ± 2.26 dB.

2.6. Test Result

EUT using DC input voltage, so the project does not have to test for testing.

3. Radiated Emission

3.1. Test Setup

Under 1GHz Test Setup:

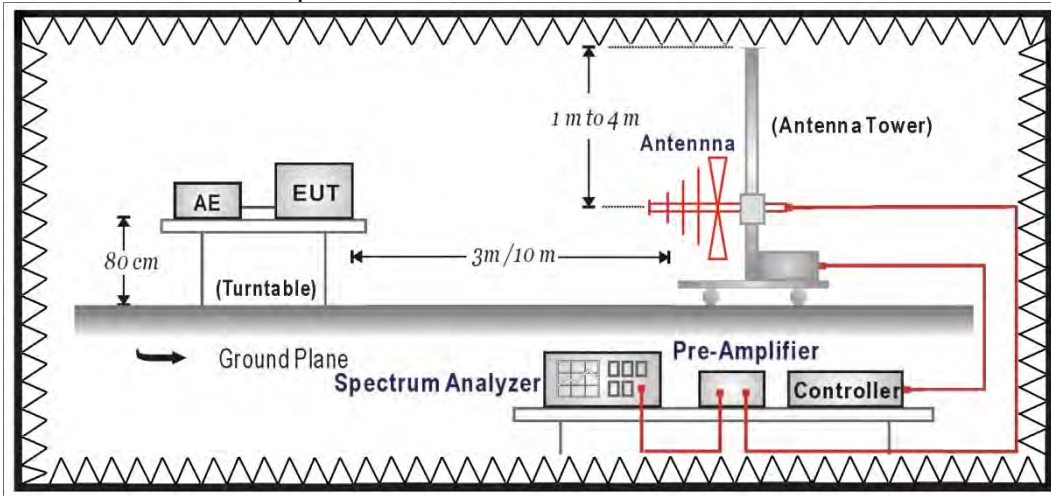

Above 1GHz Test Setup:

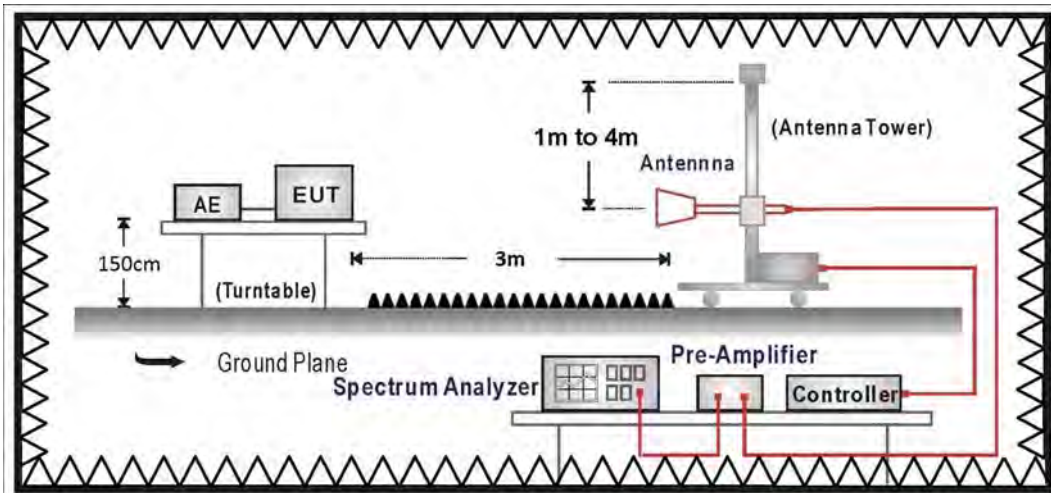

3.2. Limits

➤ Fundamental and Harmonics Emission Limits

FCC Part 15 Subpart C Paragraph 15.231(b) Limits				
Fundamental Frequency MHz	Field Strength of Fundamental		Field Strength of Harmonics	
	uV/m	dBuV/m	uV/m	dBuV/m
40.66 - 40.70	2250	67.04	225	47.04
70 - 130	1250	61.94	125	41.94
130 - 174	1250 - 3750	61.94 - 71.48	125 - 375	41.94 - 51.48
174 - 260	3750	71.48	375	51.48
260 - 470	3750 - 12500	71.48 - 81.94	375 - 1250	51.48 - 61.94
above 470	12500	81.94	1250	61.94

- Remarks: 1. RF Voltage (dBuV) = 20 log RF Voltage (uV)
2. Distance refers to the distance in meters between the measuring instrument antenna and the closed point of any part of the device or system.
3. The emission limit in this paragraph is based on measurement instrumentation employing an average detector.

➤ Spurious electric field strength limits

FCC Part 15 Subpart C Paragraph 15.209 Limits			
Frequency MHz	uV/m	dBuV/m	Measurement distance (meter)
0.009 - 0.490	2400/F(kHz)	See Remark ¹	300
0.490 - 1.705	24000/F(kHz)	See Remark ¹	30
1.705 - 30	30	29.5	30
30 - 88	100	40	3
88 - 216	150	43.5	3
216 - 960	200	46	3
Above 960	500	54	3

- Remarks : 1. RF Voltage (dBuV) = 20 log RF Voltage (uV)
2. In the Above Table, the tighter limit applies at the band edges.
3. Distance refers to the distance in meters between the measuring instrument antenna and the closed point of any part of the device or system.

3.3. Test Procedure

The EUT and its simulators are placed on a turn table which is 0.8 and 1.5 meter above ground. The turn table can rotate 360 degrees to determine the position of the maximum emission level. The EUT was positioned such that the distance from antenna to the EUT was 3 meters.

The antenna can move up and down between 1 meter and 4 meters to find out the maximum emission level.

Both horizontal and vertical polarizations of the antenna are set on measurement. In order to find the maximum emission, all of the interface cables must be manipulated according to ANSI C63.10: 2013 on radiated measurement.

The resolution bandwidth below 1GHz setting on the field strength meter is 120 kHz and above 1GHz is 1MHz.

Radiated emission measurements below 1GHz are made using broadband Bilog antenna and above 1GHz are made using Horn Antennas.

The measurement is divided into the Preliminary Measurement and the Final Measurement.

The suspected frequencies are searched for in Preliminary Measurement with the measurement antenna kept pointed at the source of the emission both in azimuth and elevation, with the polarization of the antenna oriented for maximum response. The antenna is pointed at an angle towards the source of the emission, and the EUT is rotated in both height and polarization to maximize the measured emission. The emission is kept within the illumination area of the 3 dB beamwidth of the antenna.

The worst radiated emission is measured on the Final Measurement.

The frequency range from 30MHz to 10th harmonics is checked.

3.4. Test Specification

According to FCC Part 15 Subpart C Paragraph 15.231(b): 2017

3.5. Test Result

Site :	CB4-H	Engineer :	Mark
Model No :	TX-T001	Test Date :	2018/11/30
Test Voltage :	DC 3V	Polarity :	Horizontal
Test Mode :	Mode 1: Transmit_315MHz_FSK		
Note :	315MHz_FSK_Y-axis		

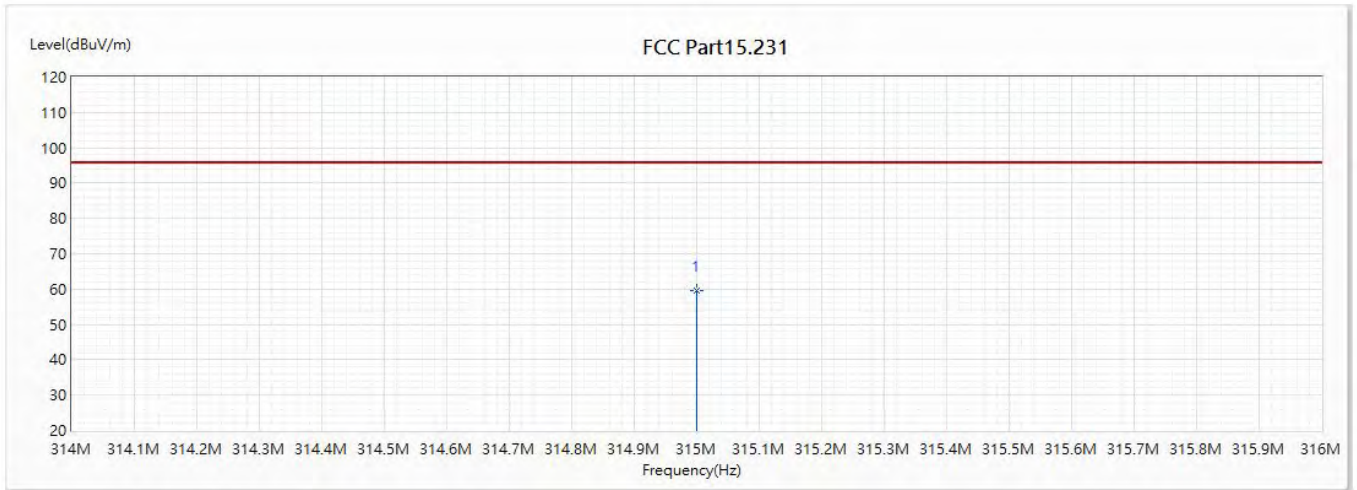

No	Frequency (MHz)	Emission Level (dBuV/m)	Limit (dBuV/m)	Margin (dB)	Reading Level (dBuV)	Correct Factor (dB)	Detector Type
* 1	315	59.46	95.62	-36.16	36.55	22.91	PK

Note:

1. All Reading Levels is Peak value.
2. “ * ”, means this data is the worst emission level.
3. Emission Level = Reading Level + Correct Factor

Site :	CB4-H	Engineer :	Mark
Model No :	TX-T001	Test Date :	2018/11/30
Test Voltage :	DC 3V	Polarity :	Vertical
Test Mode :	Mode 1: Transmit_315MHz_FSK		
Note :	315MHz_FSK_Y-axis		

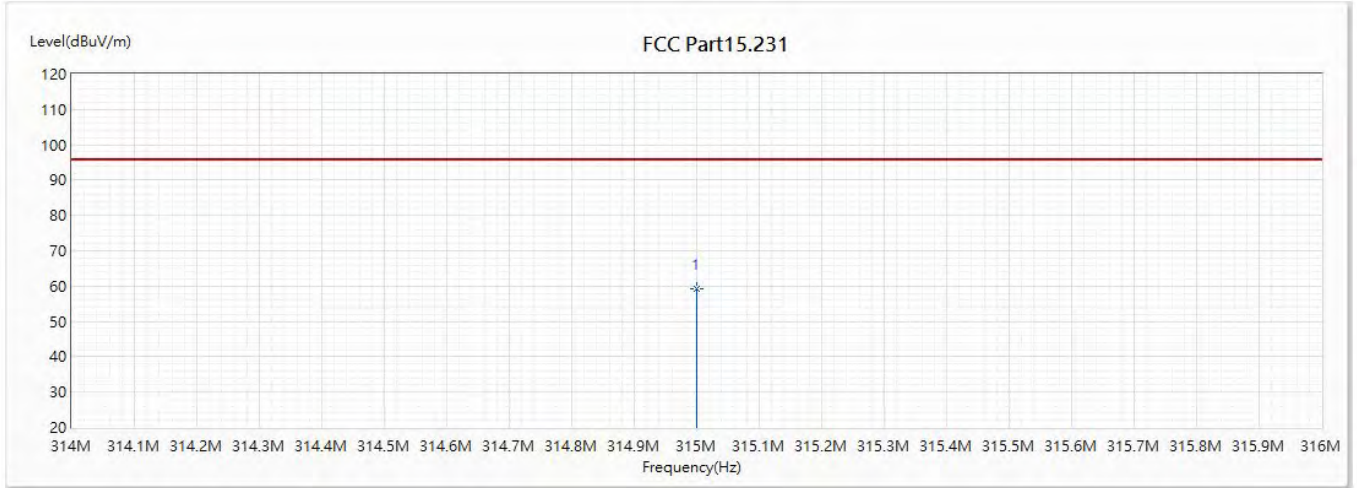

No	Frequency (MHz)	Emission Level (dBuV/m)	Limit (dBuV/m)	Margin (dB)	Reading Level (dBuV)	Correct Factor (dB)	Detector Type
* 1	315	59.13	95.62	-36.49	36.22	22.91	PK

Note:

1. All Reading Levels is Peak value.
2. “ * ”, means this data is the worst emission level.
3. Emission Level = Reading Level + Correct Factor

Product	TPMS		
Test Item	Fundamental Radiated Emission		
Test Mode	Mode 1: Transmit_315MHz_FSK		
Date of Test	2018/11/30	Test Site	CB4-H

Frequency (MHz)	Correct Factor (dB)	Reading Level (dBuV)	Peak Measurement Level (dBuV/m)	Peak Limit (dBuV/m)
Horizontal				
315 (Y-axis)	22.91	36.55	59.46	95.62
Vertical				
315 (Y-axis)	22.91	36.22	59.13	95.62

Note1:

Peak Measurement Level = Reading Level +Correct factor

Site :	CB4-H	Engineer :	Mark
Model No :	TX-T001	Test Date :	2018/11/30
Test Voltage :	DC 3V	Polarity :	Horizontal
Test Mode :	Mode 2: Transmit_315MHz_ASK		
Note :	315MHz_ASK_Y-axis		

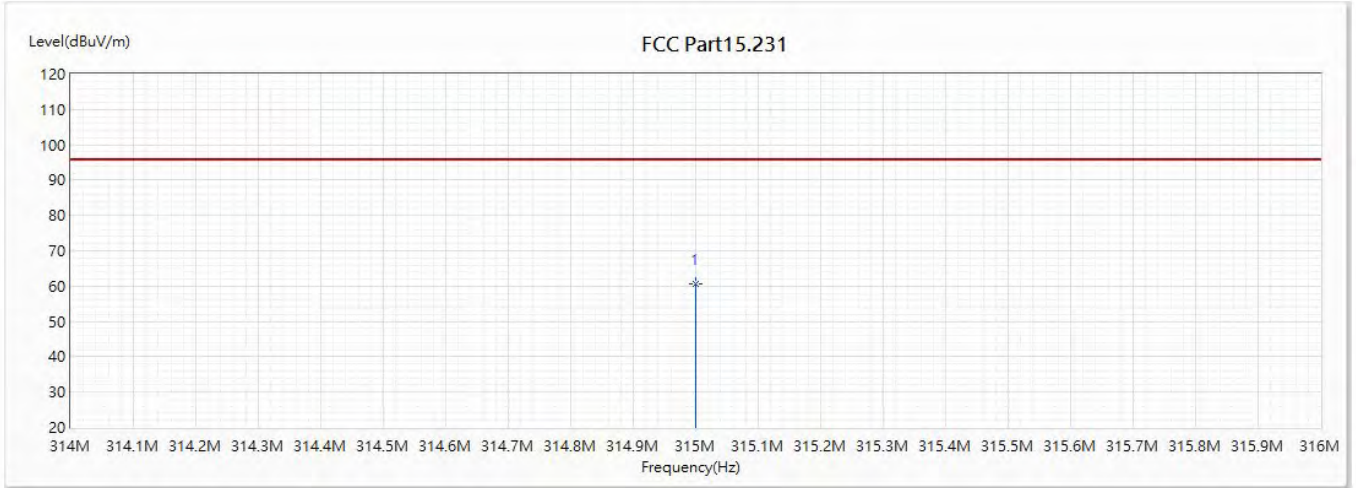

No	Frequency (MHz)	Emission Level (dBuV/m)	Limit (dBuV/m)	Margin (dB)	Reading Level (dBuV)	Correct Factor (dB)	Detector Type
* 1	315	60.54	95.62	-35.08	37.63	22.91	PK

Note:

1. All Reading Levels is Peak value.
2. “ * ”, means this data is the worst emission level.
3. Emission Level = Reading Level + Correct Factor

Site :	CB4-H	Engineer :	Mark
Model No :	TX-T001	Test Date :	2018/11/30
Test Voltage :	DC 3V	Polarity :	Vertical
Test Mode :	Mode 2: Transmit_315MHz_ASK		
Note :	315MHz_ASK_Y-axis		

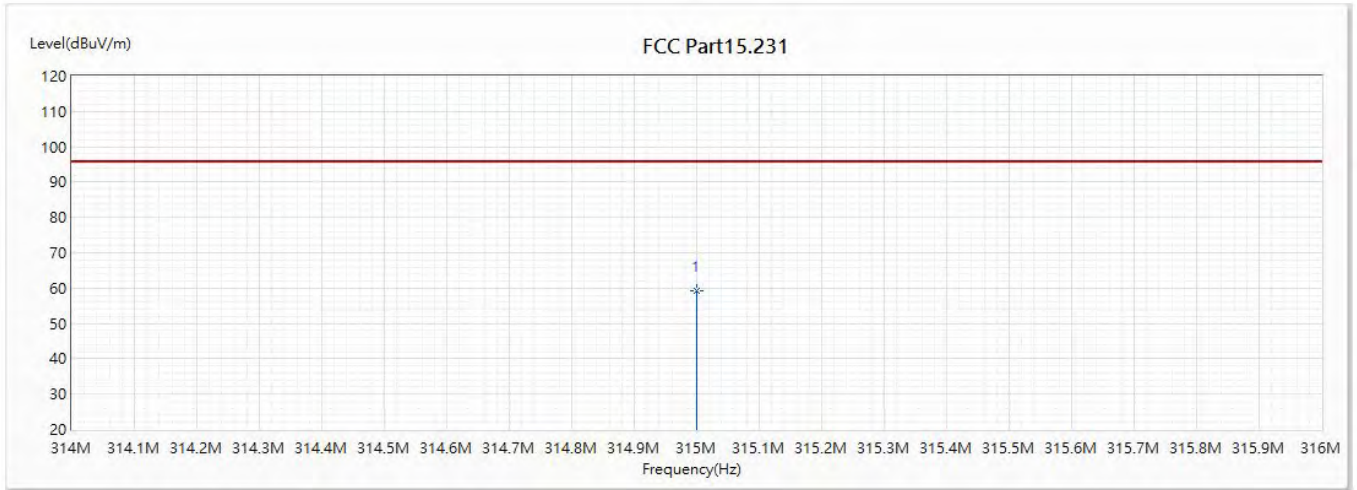

No	Frequency (MHz)	Emission Level (dBuV/m)	Limit (dBuV/m)	Margin (dB)	Reading Level (dBuV)	Correct Factor (dB)	Detector Type
* 1	315	59.38	95.62	-36.24	36.47	22.91	PK

Note:

1. All Reading Levels is Peak value.
2. “ * ”, means this data is the worst emission level.
3. Emission Level = Reading Level + Correct Factor

Product	TPMS		
Test Item	Fundamental Radiated Emission		
Test Mode	Mode 2: Transmit_315MHz_ASK		
Date of Test	2018/11/30	Test Site	CB4-H

Frequency (MHz)	Correct Factor (dB)	Reading Level (dBuV)	Peak Measurement Level (dBuV/m)	Peak Limit (dBuV/m)
Horizontal				
315 (Y-axis)	22.91	37.63	60.54	95.62
Vertical				
315 (Y-axis)	22.91	36.47	59.38	95.62

Note1:

Peak Measurement Level = Reading Level +Correct factor

30MHz-1GHz Spurious:

Site :	CB4-H	Engineer :	Mark
Model No :	TX-T001	Test Date :	2018/12/28
Test Voltage :	DC 3V	Polarity :	Horizontal
Test Mode :	Mode 1: Transmit 315MHz_FSK		
Note :	315MHz_ASK		

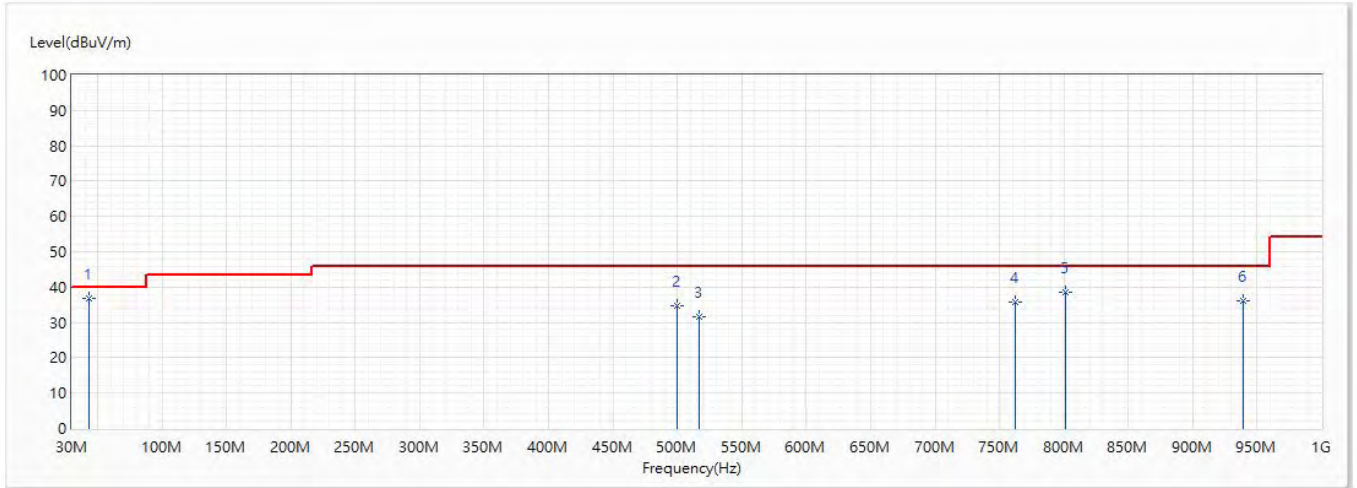

No	Frequency (MHz)	Emission Level (dBuV/m)	Limit (dBuV/m)	Margin (dB)	Reading Level (dBuV)	Correct Factor (dB)	Detector Type
* 1	43.58	36.90	40.00	-3.10	55.62	-18.72	QP
2	499.48	34.64	46.00	-11.36	48.88	-14.24	QP
3	517.231	31.60	46.00	-14.40	44.69	-13.09	QP
4	762.253	35.84	46.00	-10.16	46.75	-10.91	QP
5	801.247	38.62	46.00	-7.38	48.85	-10.23	QP
6	939.375	36.20	46.00	-9.80	44.96	-8.76	QP

Note:

1. All Reading Levels are Quasi-Peak value.
2. " * ", means this data is the worst emission level.
3. Measurement Level = Reading Level + Correct Factor.

Site :	CB4-H	Engineer :	Mark
Model No :	TX-T001	Test Date :	2018/12/28
Test Voltage :	DC 3V	Polarity :	Vertical
Test Mode :	Mode 1: Transmit 315MHz_FSK		
Note :	315MHz_ASK		

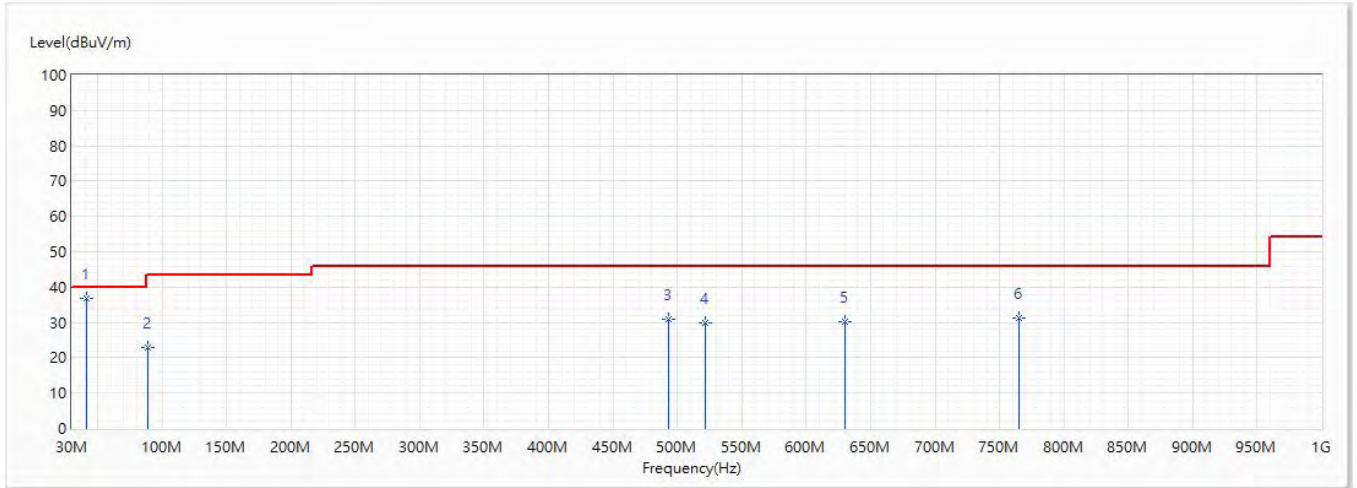

No	Frequency (MHz)	Emission Level (dBuV/m)	Limit (dBuV/m)	Margin (dB)	Reading Level (dBuV)	Correct Factor (dB)	Detector Type
* 1	41.737	36.69	40.00	-3.31	53.93	-17.24	QP
2	89.073	22.76	43.50	-20.74	47.96	-25.20	QP
3	492.787	30.87	46.00	-15.13	44.92	-14.05	QP
4	521.887	29.71	46.00	-16.29	43.17	-13.46	QP
5	629.945	30.16	46.00	-15.84	42.75	-12.59	QP
6	764.872	31.15	46.00	-14.85	42.34	-11.19	QP

Note:

1. All Reading Levels are Quasi-Peak value.
2. " * ", means this data is the worst emission level.
3. Measurement Level = Reading Level + Correct Factor.

Site :	CB4-H	Engineer :	Mark
Model No :	TX-T001	Test Date :	2018/12/28
Test Voltage :	DC 3V	Polarity :	Horizontal
Test Mode :	Mode 2: Transmit 315MHz_ASK		
Note :	315MHz_FSK		

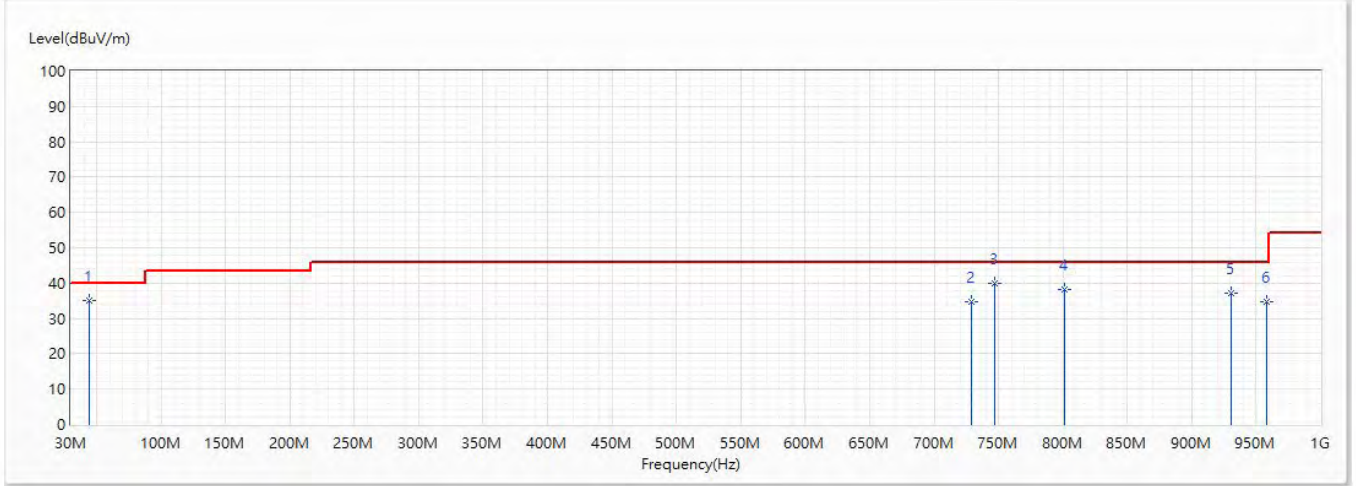

No	Frequency (MHz)	Emission Level (dBuV/m)	Limit (dBuV/m)	Margin (dB)	Reading Level (dBuV)	Correct Factor (dB)	Detector Type
* 1	44.065	34.95	40.00	-5.05	54.05	-19.10	QP
2	729.37	34.78	46.00	-11.22	45.85	-11.07	QP
3	746.83	39.79	46.00	-6.21	50.88	-11.09	QP
4	801.247	38.15	46.00	-7.85	48.38	-10.23	QP
5	930.839	37.24	46.00	-8.76	45.76	-8.52	QP
6	958.581	34.64	46.00	-11.36	43.04	-8.40	QP

Note:

1. All Reading Levels are Quasi-Peak value.
2. " * ", means this data is the worst emission level.
3. Measurement Level = Reading Level + Correct Factor.

Site :	CB4-H	Engineer :	Mark
Model No :	TX-T001	Test Date :	2018/12/28
Test Voltage :	DC 3V	Polarity :	Vertical
Test Mode :	Mode 2: Transmit 315MHz_ASK		
Note :	315MHz_FSK		

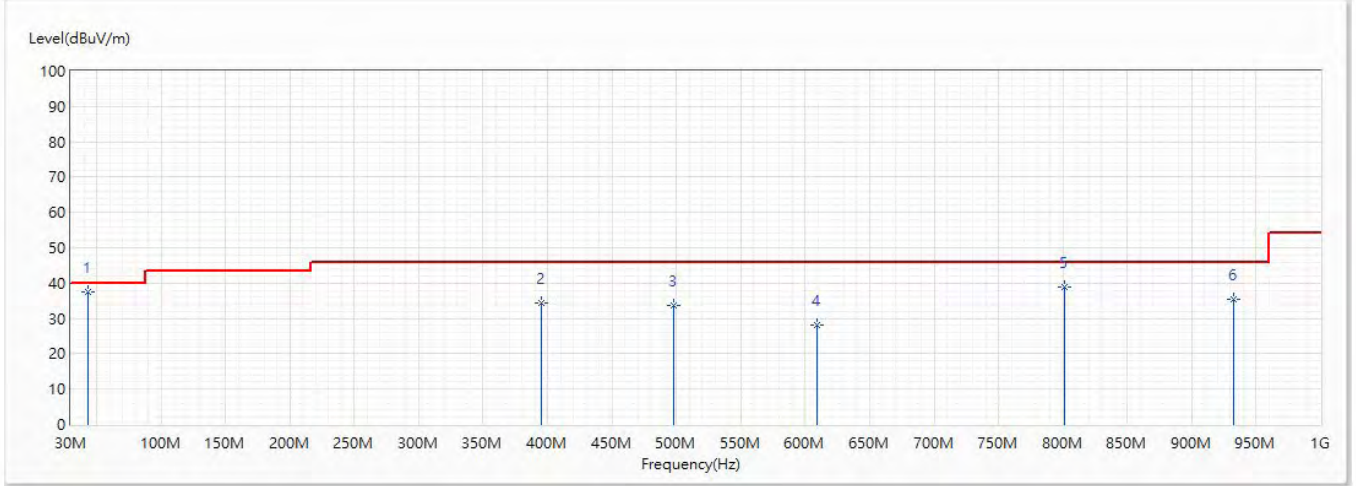

No	Frequency (MHz)	Emission Level (dBuV/m)	Limit (dBuV/m)	Margin (dB)	Reading Level (dBuV)	Correct Factor (dB)	Detector Type
* 1	43.192	37.35	40.00	-2.65	55.75	-18.40	QP
2	395.011	34.43	46.00	-11.57	50.25	-15.82	QP
3	498.316	33.75	46.00	-12.25	48.05	-14.30	QP
4	609.09	28.20	46.00	-17.80	39.85	-11.65	QP
5	801.344	38.87	46.00	-7.13	49.10	-10.23	QP
6	932.197	35.51	46.00	-10.49	43.95	-8.44	QP

Note:

1. All Reading Levels are Quasi-Peak value.
2. " * ", means this data is the worst emission level.
3. Measurement Level = Reading Level + Correct Factor.

Above 1GHz Spurious:

Site :	CB4-H	Engineer :	Mark
Model No :	TX-T001	Test Date :	2018/11/30
Test Voltage :	DC 3V	Polarity :	Horizontal
Test Mode :	Mode 1: Transmit 315MHz_FSK		
Note :	315MHz_FSK		

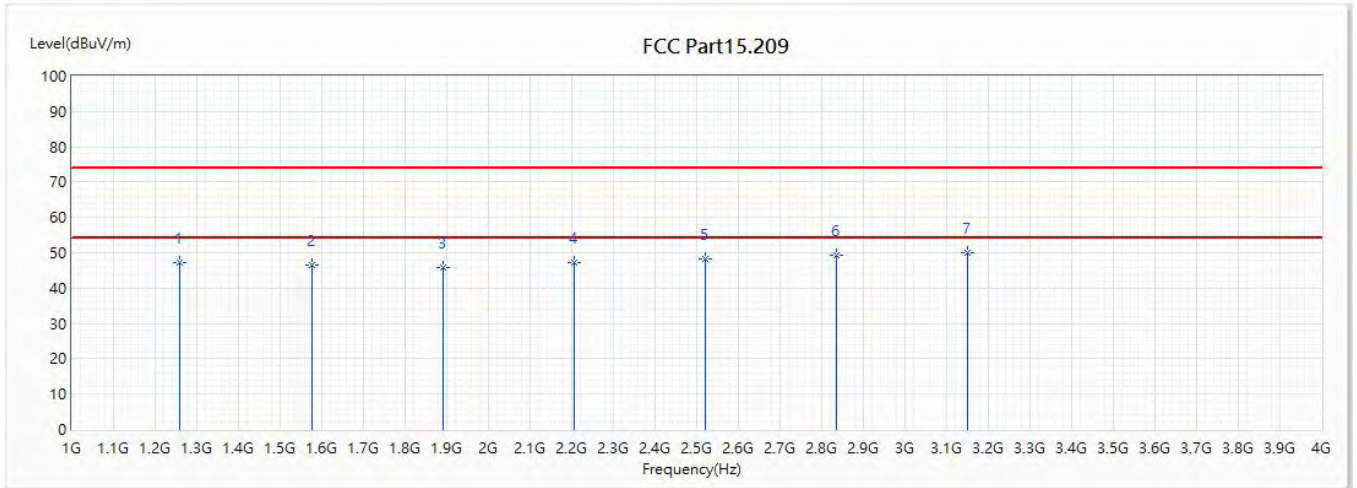

No	Frequency (MHz)	Emission Level (dBuV/m)	Limit (dBuV/m)	Margin (dB)	Reading Level (dBuV)	Correct Factor (dB)	Detector Type
1	1260	47.31	74.00	-26.69	44.98	2.33	PK
2	1575	46.63	74.00	-27.37	43.03	3.60	PK
3	1890	45.85	74.00	-28.15	40.81	5.04	PK
4	2205	47.33	74.00	-26.67	40.76	6.57	PK
5	2520	48.14	74.00	-25.86	40.03	8.11	PK
6	2835	49.27	74.00	-24.73	39.98	9.29	PK
* 7	3150	49.84	74.00	-24.16	39.46	10.38	PK

Note:

1. All reading above 1GHz is performed with peak measurements as necessary.
2. “ * ”, means this data is the worst emission level.
3. Emission Level = Reading Level + Correct Factor.

Site :	CB4-H	Engineer :	Mark
Model No :	TX-T001	Test Date :	2018/11/30
Test Voltage :	DC 3V	Polarity :	Vertical
Test Mode :	Mode 1: Transmit_315MHz_FSK		
Note :	315MHz_FSK		

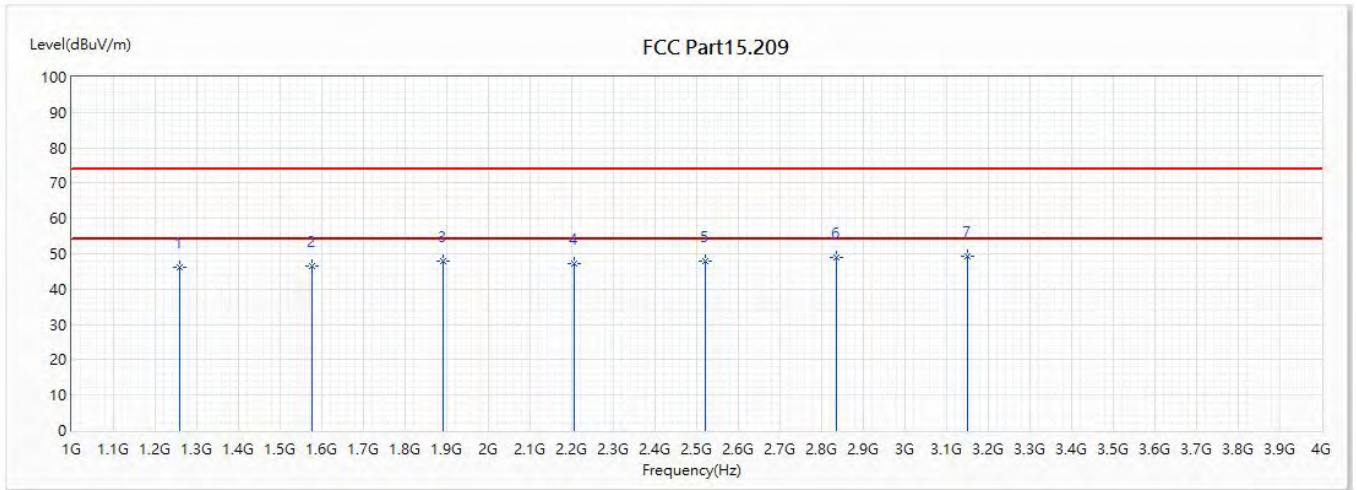

No	Frequency (MHz)	Emission Level (dBuV/m)	Limit (dBuV/m)	Margin (dB)	Reading Level (dBuV)	Correct Factor (dB)	Detector Type
1	1260	46.26	74.00	-27.74	43.93	2.33	PK
2	1575	46.55	74.00	-27.45	42.95	3.60	PK
3	1890	48.01	74.00	-25.99	42.97	5.04	PK
4	2205	47.31	74.00	-26.69	40.74	6.57	PK
5	2520	47.79	74.00	-26.21	39.68	8.11	PK
6	2835	48.93	74.00	-25.07	39.64	9.29	PK
* 7	3150	49.34	74.00	-24.66	38.96	10.38	PK

Note:

1. All reading above 1GHz is performed with peak measurements as necessary.
2. “ * ”, means this data is the worst emission level.
3. Emission Level = Reading Level + Correct Factor.

Site :	CB4-H	Engineer :	Mark
Model No :	TX-T001	Test Date :	2018/11/30
Test Voltage :	DC 3V	Polarity :	Horizontal
Test Mode :	Mode 2: Transmit_315MHz_ASK		
Note :	315MHz_ASK		

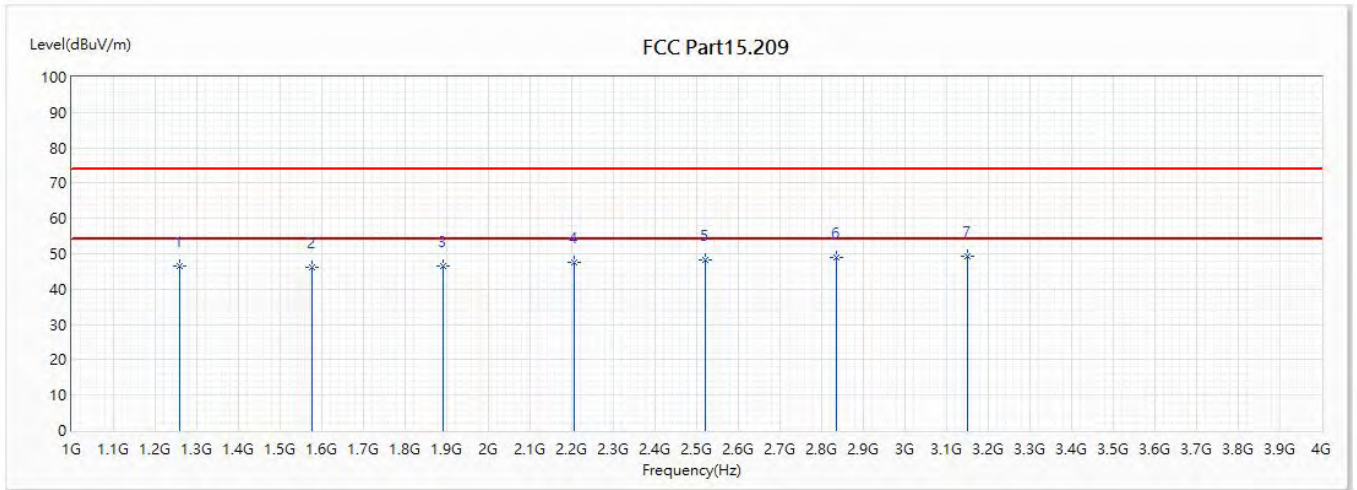

No	Frequency (MHz)	Emission Level (dBuV/m)	Limit (dBuV/m)	Margin (dB)	Reading Level (dBuV)	Correct Factor (dB)	Detector Type
1	1260	46.55	74.00	-27.45	44.22	2.33	PK
2	1575	46.21	74.00	-27.79	42.61	3.60	PK
3	1890	46.50	74.00	-27.50	41.46	5.04	PK
4	2205	47.64	74.00	-26.36	41.07	6.57	PK
5	2520	48.11	74.00	-25.89	40.00	8.11	PK
6	2835	48.98	74.00	-25.02	39.69	9.29	PK
* 7	3150	49.39	74.00	-24.61	39.01	10.38	PK

Note:

1. All reading above 1GHz is performed with peak measurements as necessary.
2. “ * ”, means this data is the worst emission level.
3. Emission Level = Reading Level + Correct Factor.

Site :	CB4-H	Engineer :	Mark
Model No :	TX-T001	Test Date :	2018/11/30
Test Voltage :	DC 3V	Polarity :	Vertical
Test Mode :	Mode 2: Transmit 315MHz_ASK		
Note :	315MHz_ASK		

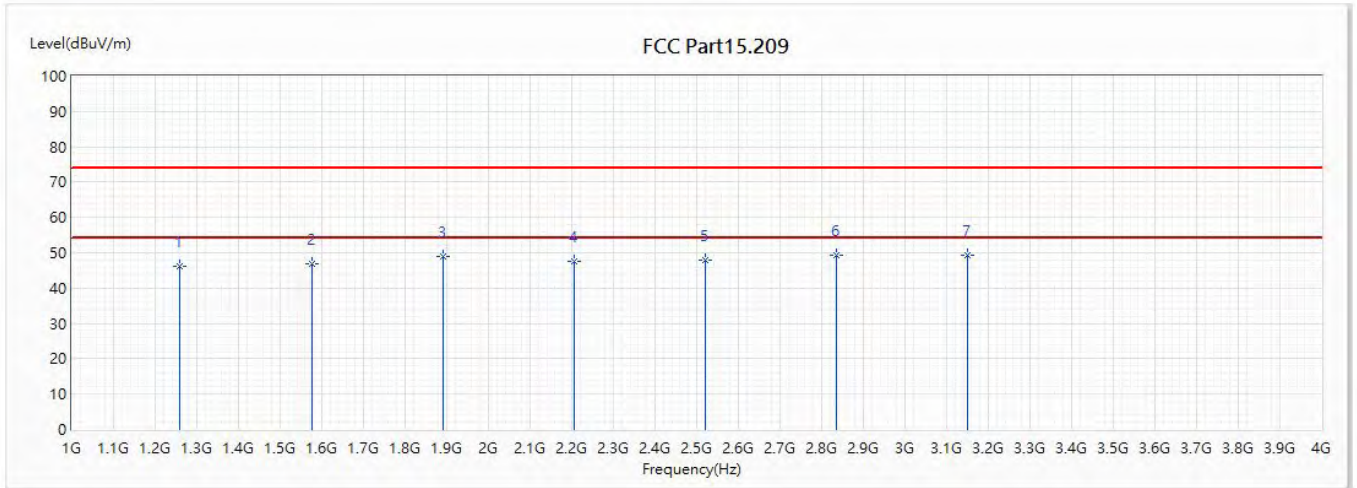

No	Frequency (MHz)	Emission Level (dBuV/m)	Limit (dBuV/m)	Margin (dB)	Reading Level (dBuV)	Correct Factor (dB)	Detector Type
1	1260	46.05	74.00	-27.95	43.72	2.33	PK
2	1575	47.00	74.00	-27.00	43.40	3.60	PK
3	1890	48.97	74.00	-25.03	43.93	5.04	PK
4	2205	47.44	74.00	-26.56	40.87	6.57	PK
5	2520	48.08	74.00	-25.92	39.97	8.11	PK
* 6	2835	49.40	74.00	-24.60	40.11	9.29	PK
7	3150	49.38	74.00	-24.62	39.00	10.38	PK

Note:

1. All reading above 1GHz is performed with peak measurements as necessary.
2. “ * ”, means this data is the worst emission level.
3. Emission Level = Reading Level + Correct Factor.

4. Occupied Bandwidth

4.1. Test Setup

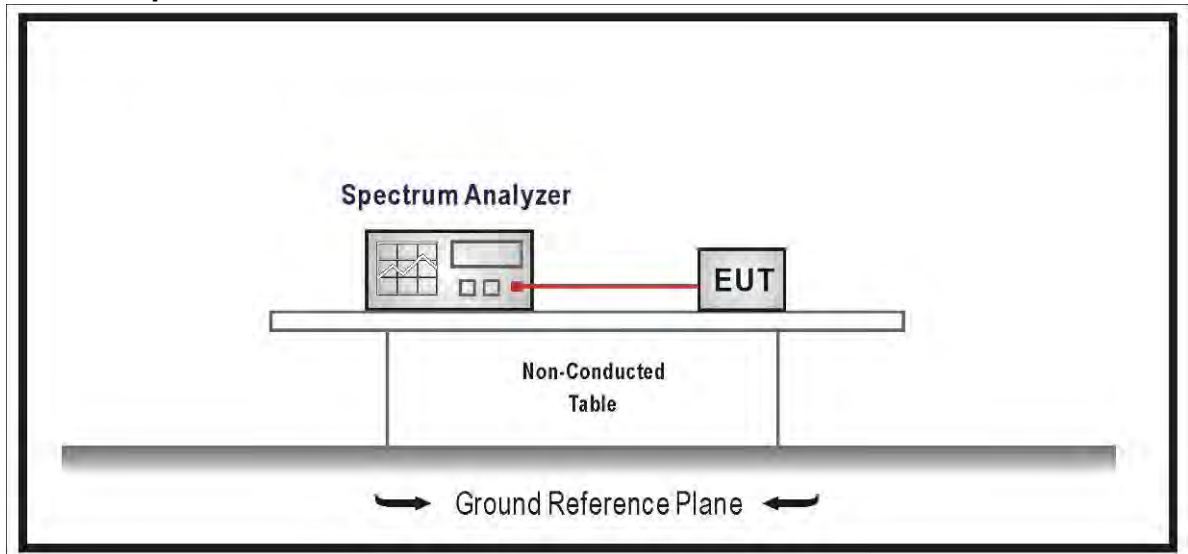

4.2. Limits

The bandwidth of the emission shall be no wider than 0.25% of the center frequency for devices operating above 70 MHz and below 900 MHz. For devices operating above 900 MHz, the emission shall be no wider than 0.5% of the center frequency. Bandwidth is determined at the points 20 dB down from the modulated carrier.

4.3. Test Specification

According to FCC Part 15 Subpart C Paragraph 15.231(b): 2017

4.4. Test Result

Product	TPMS		
Test Item	Occupied Bandwidth		
Test Mode	Mode 1: Transmit_315MHz_FSK		
Date of Test	2018/12/03	Test Site	SR10-H

Channel No.	Frequency (MHz)	Measure Level (MHz)	Limit (MHz)	Result
1	315.000	0.111	0.7875	Pass

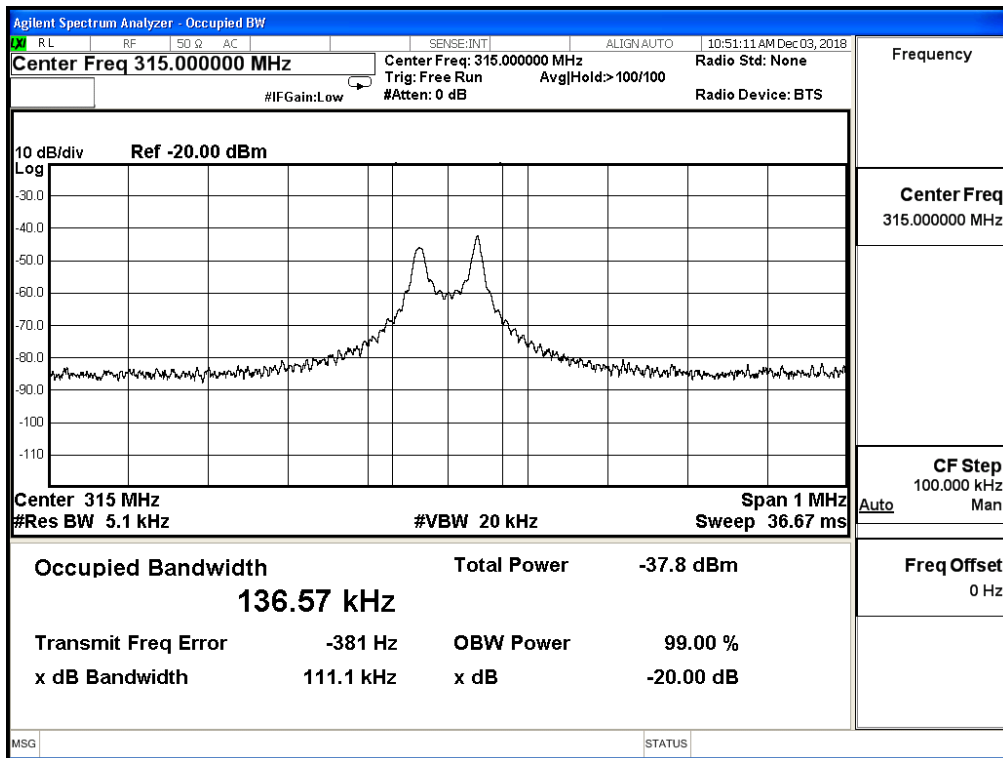

Product	TPMS		
Test Item	Occupied Bandwidth		
Test Mode	Mode 2: Transmit_315MHz_ASK		
Date of Test	2018/12/03	Test Site	SR10-H

Channel No.	Frequency (MHz)	Measure Level (MHz)	Limit (MHz)	Result
1	315.000	0.064	0.7875	Pass

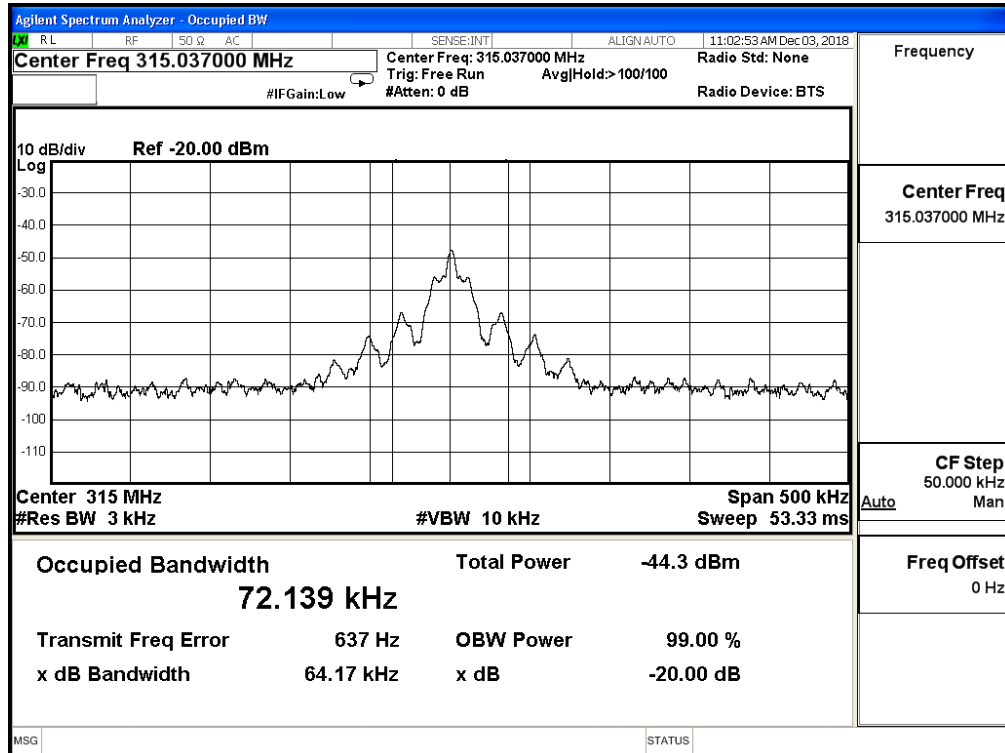

5. Transmitter time

5.1. Test Setup

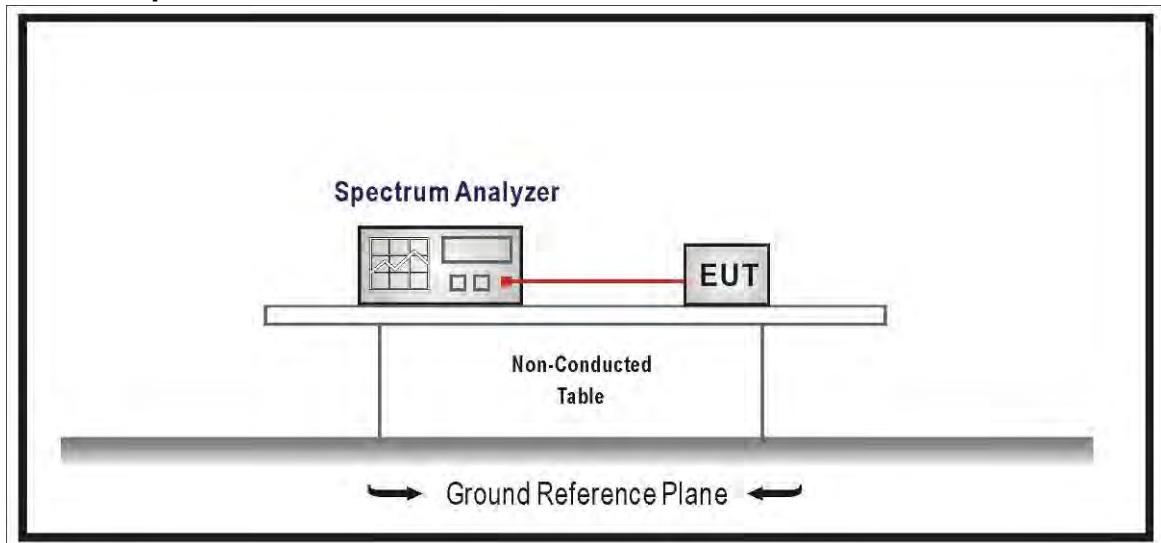

5.2. Limits

A manually operated transmitter shall employ a switch that will automatically deactivate the transmitter within not more than 5 seconds of being released. A transmitter activated automatically shall cease transmission within 5 seconds after activation.

5.3. Test Specification

According to FCC Part 15 Subpart C Paragraph 15.231(b): 2017

5.4. Test Result

Product	TPMS		
Test Item	Transmitter time		
Test Mode	Mode 1: Transmit_315MHz_FSK		
Date of Test	2018/12/03	Test Site	SR10-H

Frequency(MHz)	Total duration of transmissions per hour (sec)	
315	Measure Value (s)	Limit (s)
	1.102	≤ 2

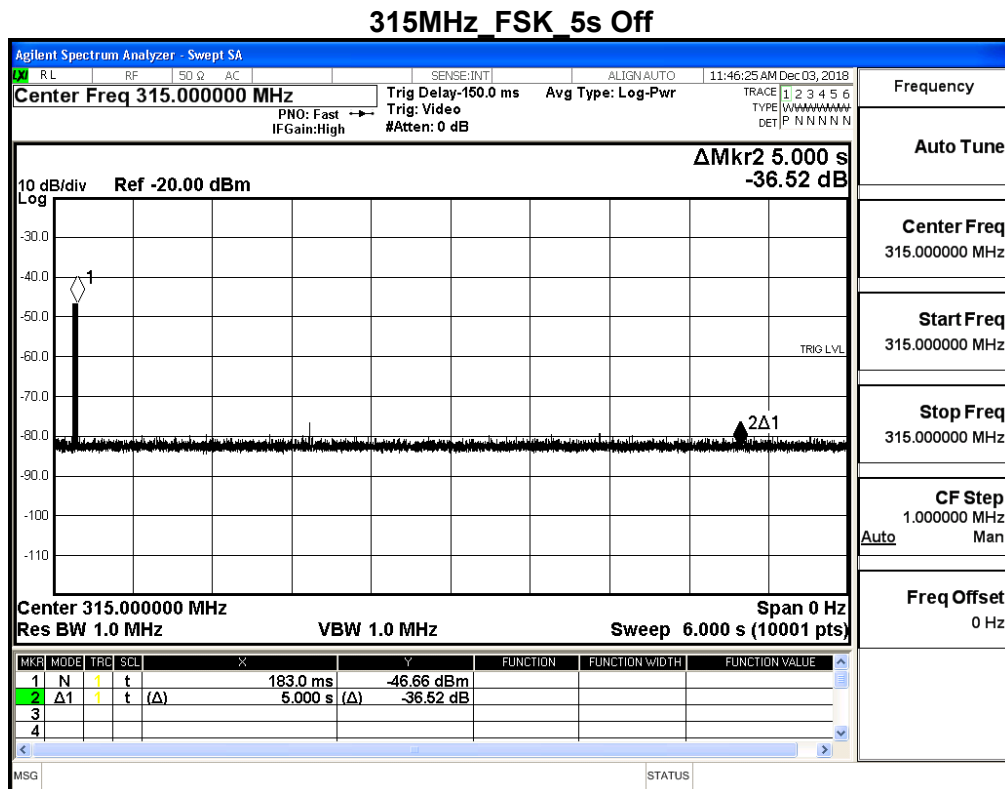

315MHz_FSK_200s

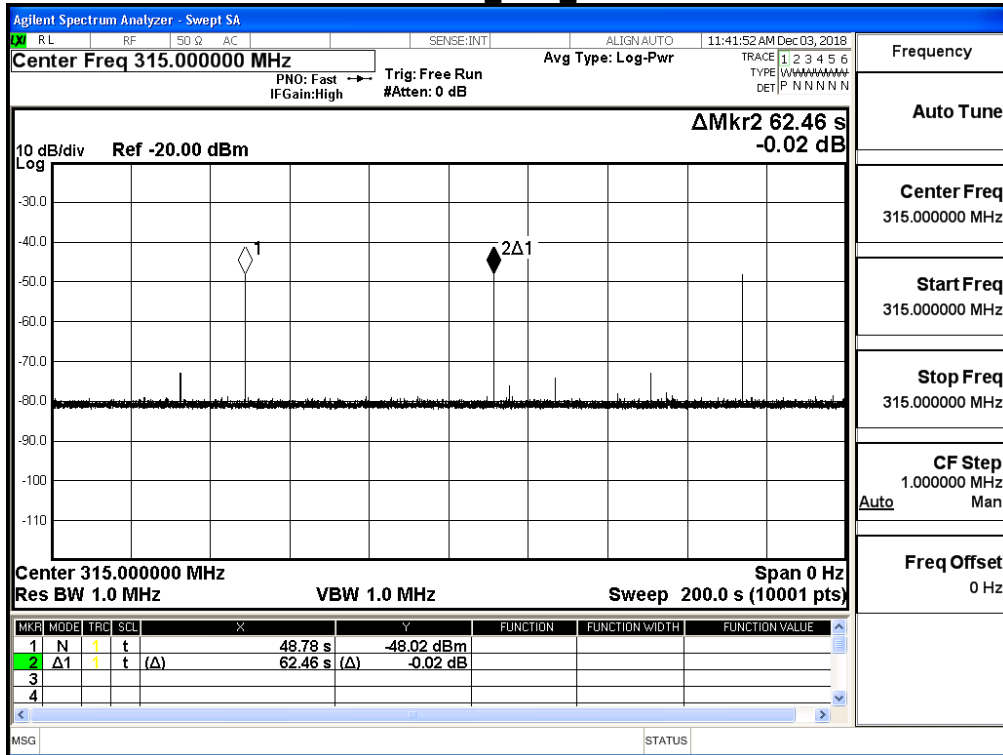

315MHz_FSK_Ontime

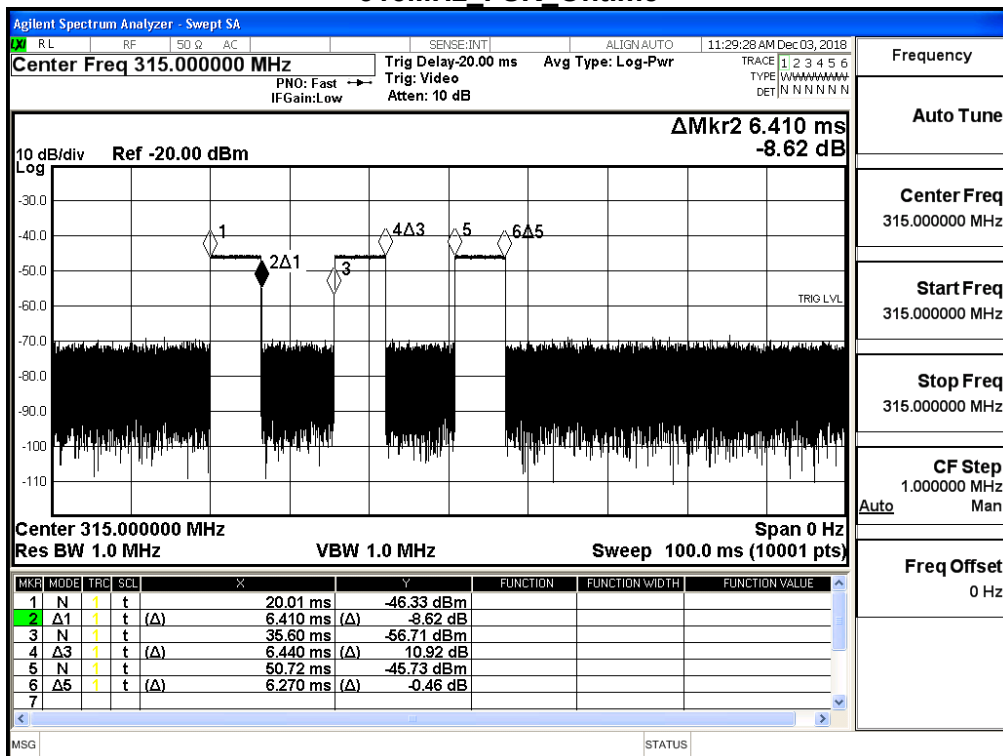

Product	TPMS		
Test Item	Transmitter time		
Test Mode	Mode 2: Transmit_315MHz_ASK		
Date of Test	2018/12/03	Test Site	SR10-H

Frequency(MHz)	Total duration of transmissions per hour (sec)	
315	Measure Value (s)	Limit (s)
	1.105	≤ 2

315MHz ASK 5s Off

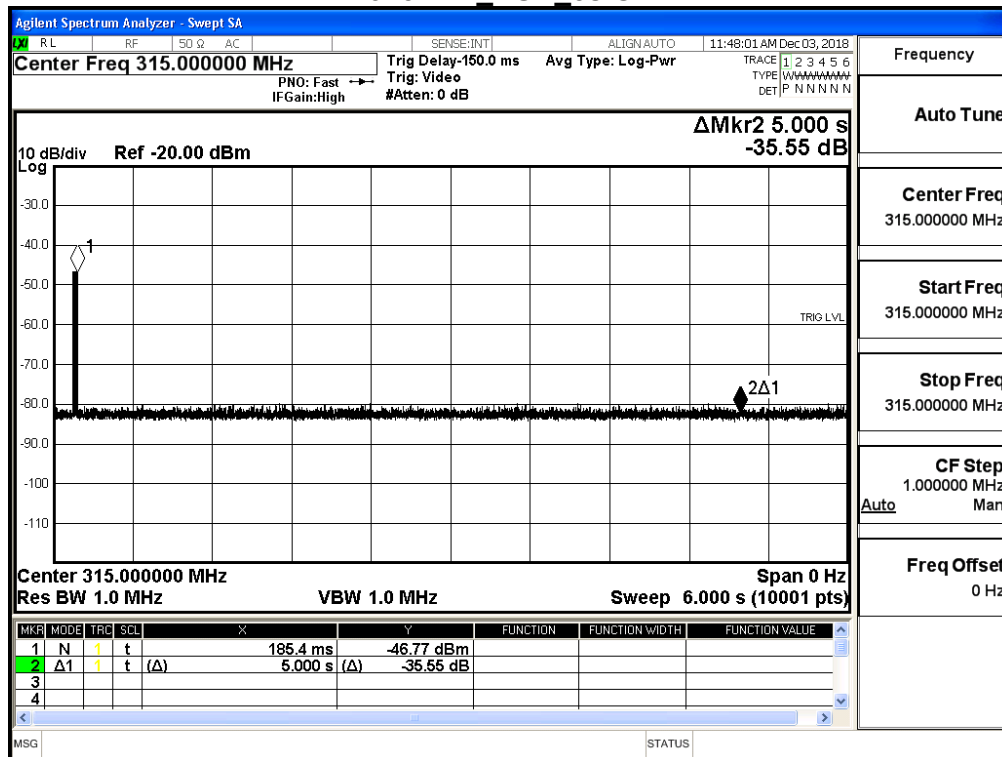

315MHz ASK 90s

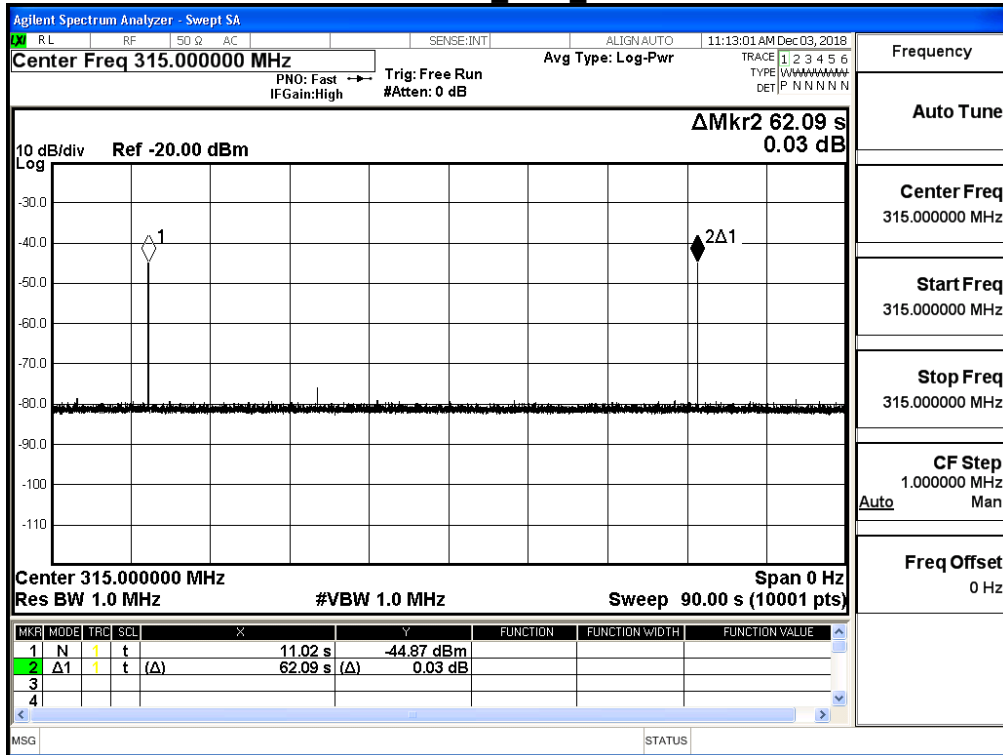

315 ASK Ontime

