





	For review by:		
Issue	No. 1.3	Date 12/04/07	
Description of Revision	Rev. 5	Date 2706/07	Prepared: A. Piccioli Approved:
			

NOTES:

This apparatus and its documentation must be thoroughly reviewed, to become familiar with safety instructions before starting operating procedures.

To assure a correct and safe utilisation, the user of this apparatus shall observe all information and warnings contained herein.

The Apparatus must be connected to an electrical system that complies with current national standards.

The information contained herein is subjected to change without advance notice.

This device complies with Part 15 of the FCC Rules. Operation is subject to the following two conditions:

- (1) this device may not cause harmful interference, and
- (2) this device must accept any interference received, including interference that may cause undesired operation.

Changes or modifications not expressly approved by the party responsible for compliance could void the user's authority to operate the equipment.

TABLE OF WRITTEN CONTENTS

1. SECURITY INSTRUCTIONS AND CONSIDERATIONS.....	1-5
2. ABBREVIATIONS	2-5
3. GENERAL INFORMATION	3-6
3.1. OPERATING PRINCIPLE OF THE LNX SYSTEM	3-6
<i>STANDARD, FAST and APB Mode</i>	3-7
<i>TRACK Mode</i>	3-8
<i>ECM Mode</i>	3-9
<i>BEEPER FAST Mode</i>	3-10
3.2. EXAMPLES OF APPLICATIONS OF THE LNX SYSTEM	3-11
4. TECHNICAL DESCRIPTION OF THE DEVICES.....	4-13
4.1. ILLUMINATOR UKOPLX2101FHU	4-13
<i>Mechanical Characteristics</i>	4-13
<i>Mechanical Characteristics</i>	4-14
<i>Wiring for UKOPLX2101FHU</i>	4-14
<i>POSITION OF LABEL</i>	4-14
4.2. TAG DUALFREQUENCY UKOPLX1004STU & UKOPLX1004QDU	4-15
<i>Mechanical Characteristics</i>	4-15
<i>Wiring for UKOPLX1004STU or UKOPLX1004QDU</i>	4-16
<i>POSITION OF LABEL</i>	4-16
4.3. UKOPLX2002 RADIO RECEIVER	4-17
<i>Mechanical Characteristics</i>	4-17
<i>Wiring for UKOPLX2002</i>	4-17
<i>POSITION OF LABEL</i>	4-18
5. INSTALLATION	5-19
5.1. INTRODUCTION	5-19
<i>Illuminator UKOPLX2101FHU</i>	5-19
<i>Receiver UKOPLX2002</i>	5-19
<i>Transponder UKOPLX1004STU or UKOPLX1004QDU</i>	5-19
5.2. PRECAUTIONS	5-20
<i>Initial Inspection</i>	5-20
<i>Packing and Unpacking</i>	5-20
<i>Preparation for Use</i>	5-20
<i>Caution</i>	5-20
<i>Connection to Power Supply Mains</i>	5-21
5.3. TECHNICAL CHARACTERISTICS OF THE MATERIALS EMPLOYED	5-21
<i>Power supply cord</i>	5-21
<i>Data cables</i>	5-21
<i>Auxiliary cables</i>	5-22
<i>Environmental conditions</i>	5-22
<i>Cleaning the instrument</i>	5-22
<i>Caution</i>	5-22
5.4. NOTES ON INSTALLATION	5-22
<i>Installation</i>	5-22
<i>Equipment required for installation</i>	5-22
<i>Notes on installation</i>	5-23

Caution.....	5-23
5.5. INSTALLATION OF THE APPARATUS	5-24
5.6. STARTING THE APPARATUSES	5-27
5.7. CONFIGURATION OF ILLUMINATOR UKOPLX2101FHU	5-28
5.8. CONFIGURATION OF TRASPONDER UKOPLX1004STU / UKOPLX1004QDU	5-40
5.9. CONFIGURATION OF RECEIVER UKOPLX2002	5-44
<i>Supplementary power supply</i>	5-44
<i>External interface</i>	5-45
<i>Operating mode</i>	5-48
<i>Startup</i>	5-48
<i>LEDs</i>	5-48
<i>Button functions</i>	5-48
<i>STAND ALONE MODE</i>	5-49
<i>ASCII Stand Alone data format</i>	5-49
<i>Programming</i>	5-51
<i>NETWORKING</i>	5-54
<i>Binary communication protocol</i>	5-54
6. ELECTRICAL AND MECHANICAL SPECIFICATIONS.....	6-64
6.1. ACTIVATOR UKOPLX2101FHU	6-64
<i>Mechanical characteristics</i>	6-64
<i>External interface</i>	6-64
<i>Electrical characteristics</i>	6-64
<i>Environmental specifications</i>	6-64
<i>Radio unit specifications</i>	6-64
<i>Antenna specifications: AME ANT 2.44</i>	6-65
6.2. TRASPONDER UKOPLX1004STU & UKOPLX1004QDU	6-66
<i>Mechanical characteristics</i>	6-66
<i>UKOPLX1004STU</i>	6-66
<i>UKOPLX1004QDU</i>	6-66
<i>Electrical characteristics</i>	6-66
<i>Environmental specifications</i>	6-66
<i>Radio Frequency Specifications</i>	6-67
<i>433 MHz. transmitter</i>	6-67
<i>2.45 GHz receiver</i>	6-67
6.3. RECEIVER UKOPLX2002	6-68
<i>Mechanical characteristics</i>	6-68
<i>Electrical characteristics</i>	6-68
<i>Specific external interfaces</i>	6-68
<i>Radio Frequency Specifications</i>	6-68
<i>Environmental specifications</i>	6-68
7. LAN PLX2002 CONFIGURATION (OPTIONAL FUNCTION)	7-69
8. STARTING THE APPARATUS.....	8-69
9. TEST	9-69
10. PRECAUTIONS	10-69
11. MAINTENANCE.....	11-70



1. SECURITY INSTRUCTIONS AND CONSIDERATIONS

This apparatus complies with the safety requirements set out by current standards. To assure a proper and safe use of this apparatus, it is necessary thoroughly to understand and carefully to observe the following instructions, before starting operating procedures.

- If the unit is to be connected to other apparatuses or accessories, before powering each unit ensure that there is continuity in the ground connection between them.
- For units connected permanently without protection fuses, automatic breaking circuits or similar solutions, mains voltage must be supplied through fuses or protections connected to the units themselves.
- Every interruption or loosening of the protective conductor, inside or outside the unit or in a connection to other units, will cause a potential electric shock hazard which could result in personal injuries.
- The protective conductor must not be interrupted intentionally.
- To prevent electric shocks, do not remove protections or lids from the unit; to service the apparatus, contact a qualified service centre.
- To assure continuous protection against the risk of fire, replace the fuses on the power supply mains only with fuses of the same type and size.
- Comply with safety standards and rules, and also with the additional accident prevention instructions specified herein.

2. ABBREVIATIONS

RFID	Radio Frequency Identification
PLX1004STU	Similar to UKOPLX1004STU , Identifying code for the rectangular TAG
PLX1004QDU	Similar to UKOPLX1004QDU , Identifying code for the square TAG
PLX2002	Similar to UKOPLX2002 , Identifying code for the RECEIVER
PLX2101FHU	Similar to UKOPLX2101FHU , Identifying code for the ILLUMINATOR
IT System	IT apparatus dedicated to managing the data acquired by the system
Activtor	Similar to UKOPLX2101FHU
Illuminator	Similar to UKOPLX2101FHU
Receiver	Similar to UKOPLX2002
ILL	Similar to UKOPLX2101FHU
RIC	Similar to UKOPLX2002
TAG	Similar to UKOPLX1004STU or UKOPLX1004QDU

3. GENERAL INFORMATION

3.1. Operating Principle of the LNX System

The system proposed herein is based on the extensive use of LNX technology apparatuses. Therefore, it is essential to provide a short note describing the specific characteristics and potential of this technology.

The LNX system is based on the operating principle of Radio Frequency Identification (RFID) systems with ACTIVE transponder.

An active transponder is a self-powered electronic device with the ability to receive data through a transmission at 2.45GHz, process them, and make the results available through a transmission at 433MHz.

The system as a whole is thus formed by three elements:

- The ILLUMINATOR, tasked with generating the transmission at 2.45GHz and produce a coverage area.
- The ACTIVE TRANSPONDER, which will be designated with the acronym TAG (whose operation we have already described)
- The RECEIVER, tasked with receiving the data transmitted by the TAG and transferring them in turn to the IT system above it.



The operating principle is extremely simple: the transponder lies in a stand-by state until it is “illuminated” by the microwave source which “awakens” it.

Only then does it “activate”, interpret the signal transmitted by the illuminator, perform the necessary operations and transmit its code and the results obtained on the RF channel to the receiver located within the coverage range.

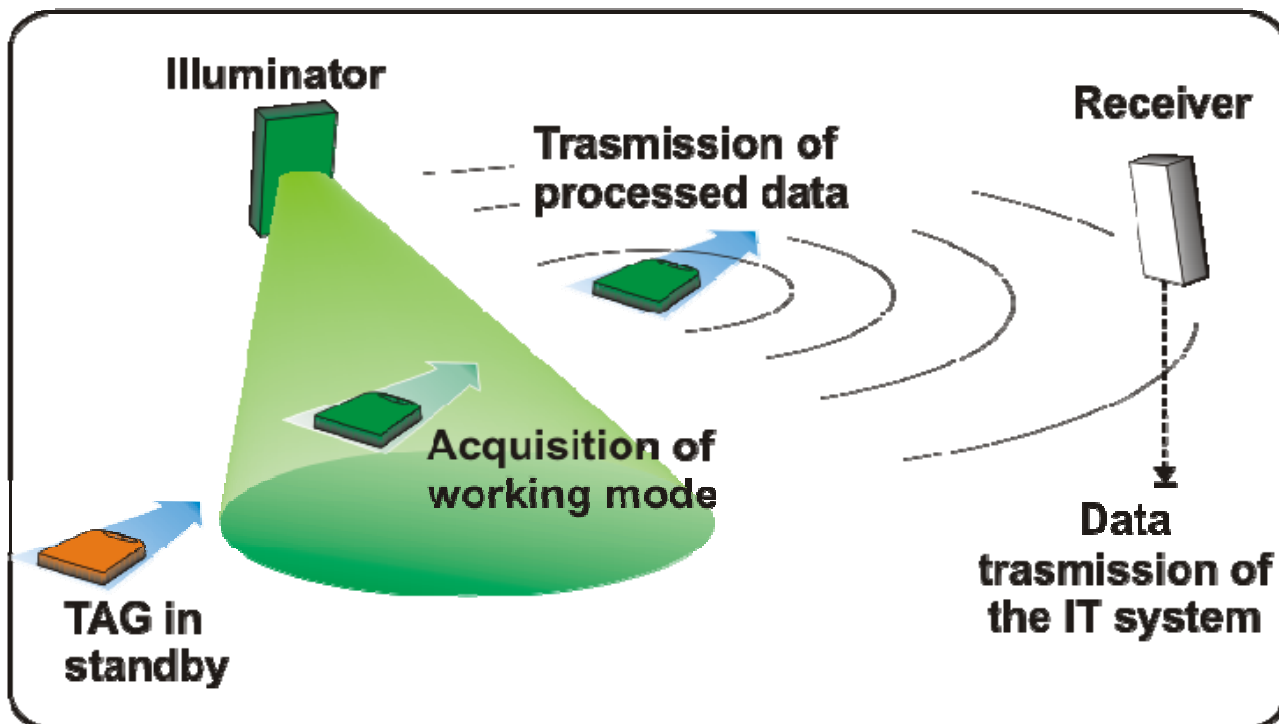

Moreover, since the active transponder of the LNX system is an apparatus with on-board frequency generation and it is provided with battery as well as a chip and a transmitter, the TAG can become a transmission device irrespective of whether it is located in the activation area.

This allows the firmware loaded in the TAG's memory to perform numerous processes and to transmit the result at any time and for an infinite number of times.

This intrinsic characteristic of the LNX system enables to use the same products (receiver, illuminator, TAG) in various applications, even very different ones.

The following is the description of the work modes currently implemented on the LNX system.

STANDARD, FAST and APB Mode

In this mode, the TAG activates its transmission when it is illuminated by an illuminator.

A similar operation to standard mode also occurs with the FAST and APB modes (described below); for now, suffice it to know that they are differentiated by the transmission and waiting times.

Standard, Fast, APB Working mode

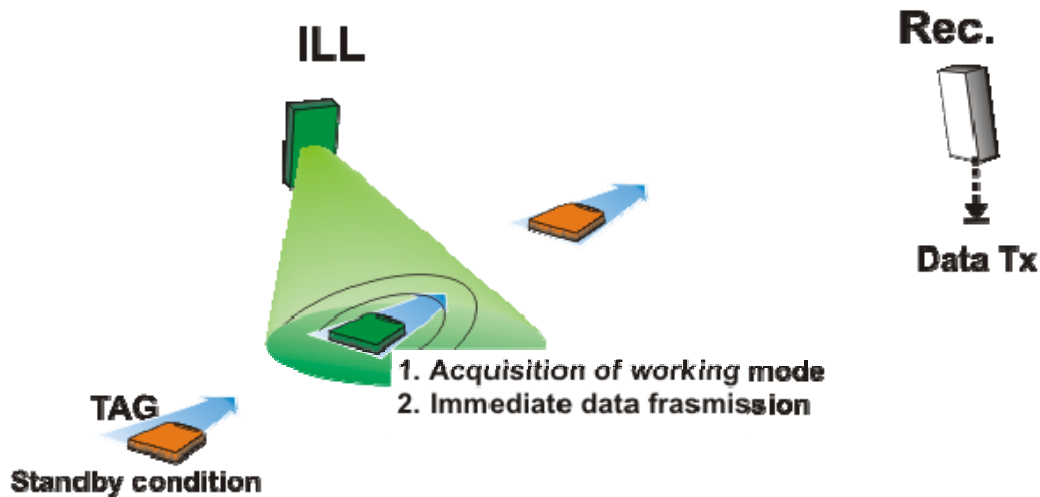

TRACK Mode

Operating mode that enables to track a TAG's path through an area where multiple illuminators are positioned.

TRACK working mode

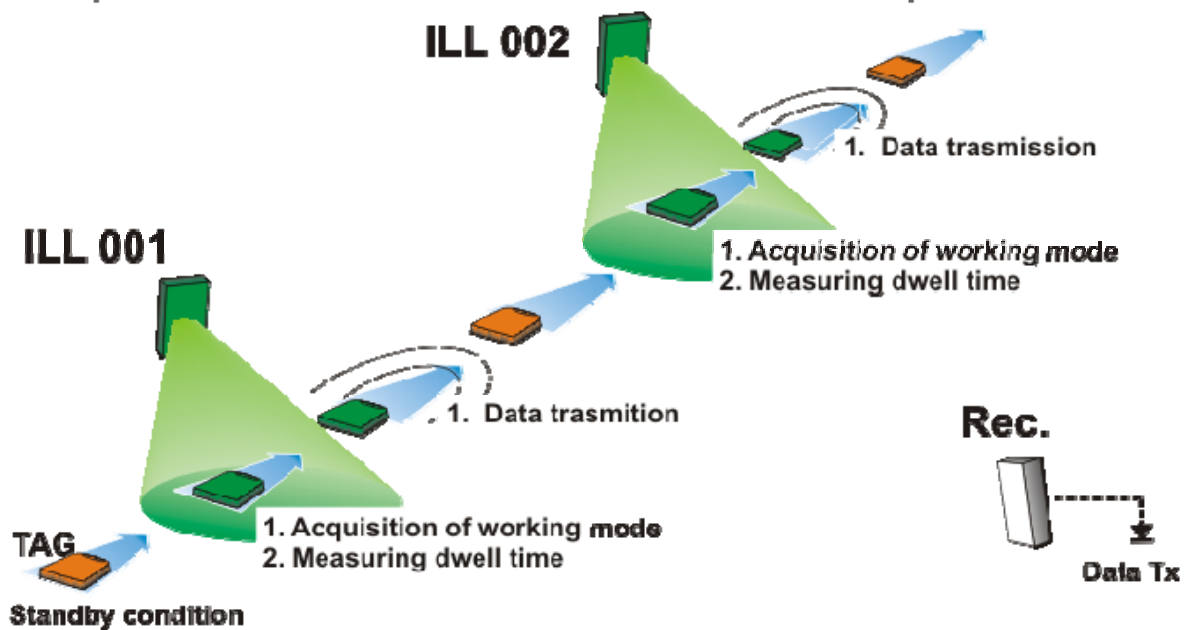

From the data transmitted by the TAG it is possible to know by which illuminators the TAG was successively illuminated and how long it remained within their operating range.

ECM Mode

Operating mode that enables a TAG's passage through a barrier, while also keeping track of the direction of travel.

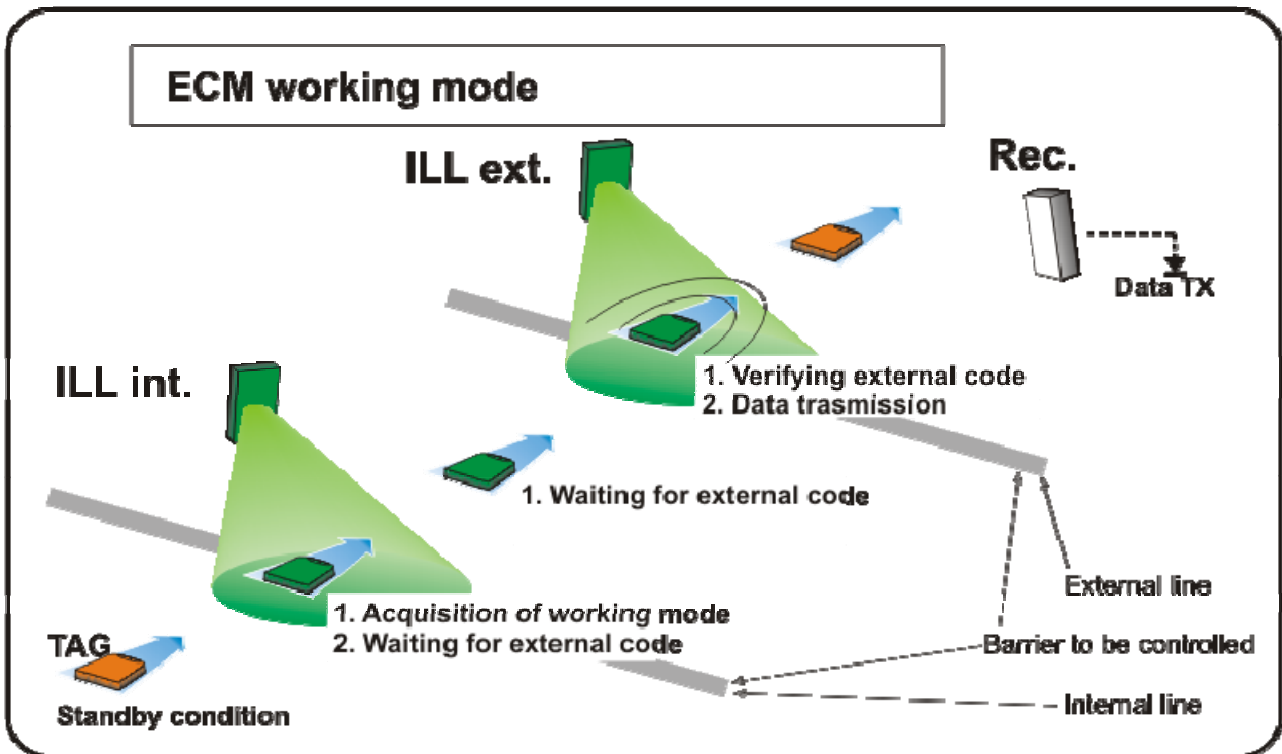

If the barrier is wide, the system provides for the illuminators to be so configured as to enable the creation of barriers of up to 15m, with performance optimisation.

BEEPER FAST Mode

This mode enables to excite the TAG and to set it to a condition of repetitive transmission of the same message for a defined time, even after it leaves the activation area.

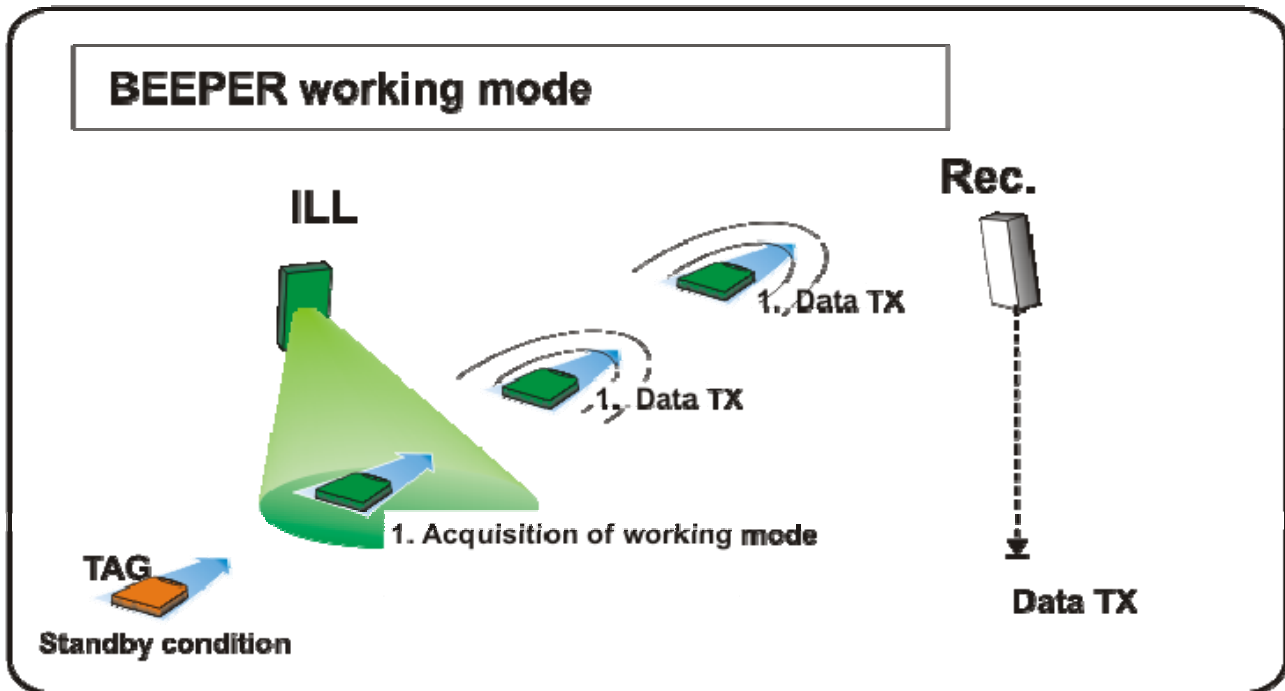

Observing the configuration tables provided in the remainder of this manual, it will be readily apparent that for this particular configuration, 32 versions are available, plus 22 of the BEEPER FAST mode.

The difference between the BEEPER FAST mode is that with the former the TAG changes working mode only at the end of its transmission cycle, or upon receiving the code 999I or 999E code by an illuminator. With the BEEPER FAST mode, instead, the TAG changes its operating mode every time it is activated by an illuminator with different work settings.

3.2. Examples of Applications of the LNX System

There are many applications of the LNX system in the various work modes described above.

STANDARD Mode: example of application for the management of vehicle accesses.

The TAG is positioned on the vehicle, the illuminator and the receiver are positioned near the motorised barrier. When the illuminator activates the TAG, the latter transmits its code to the receiver. The receiver processes the data, verifies the TAG's authorizations and proceeds to open the barrier.

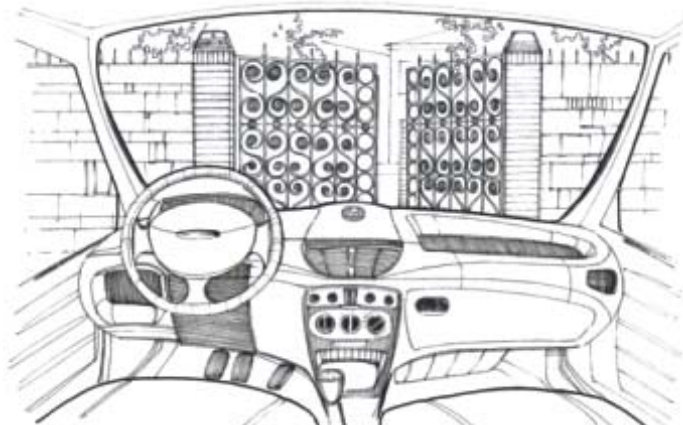

FAST Mode: allows to use the system described above to monitor travel times between an illuminator and the next one. In this mode, therefore, the system functions as a time-measuring system.

TRACK Mode: enables to monitor the movements of "labeled" objects or to verify at any time their stage of production.

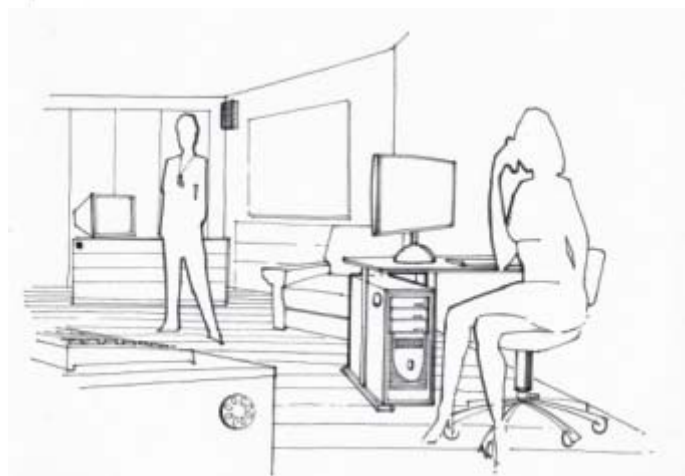

LNx is able to cover any activation radius of the transponder, up to about 12 meters; in turn, the transponder is able to communicate efficiently up to about 60 meters in a free area.

The LNx technology allows to produce even highly complex systems at low costs, allowing to automate both industrial and private facilities.

Today, the LNx system is the most modern, effective and economical solution of hands-free short-range automatic identification and data exchange indoors and outdoors (Italian patent FI2000A000221 of November 6, 2000, and European Patent (pending) no. EP1209615)

- ability to modulate activation ranges (up to 12 m)
- large code communication coverage areas (up to 60 m)
- multi-receiver operation
- very low consumption for long transponder operating times
- precise spatial definition of the activation area

4. TECHNICAL DESCRIPTION OF THE DEVICES

The following is the description of the components of the LNX system:

4.1. Illuminator UKOPLX2101FHU



CODED ILLUMINATOR LX2101 generates an encoded signal at 2.45GHz to activate the LX1004 Dual Frequency Tag.

The device needs only the 12/24V direct (V_{dc}) or alternating (V_{ac}) power supply; once it is powered, it will start continuously transmitting its own code.

In compliance with the ETSI EN 300-440 standard, it transmits with power levels below +20 dBm (100 mW), which cannot be incremented.

The influence lobe with circular conical shape which emits microwaves has an overall opening of about 90° - 100°, within which are activate the

LX1004 transponders.

A representation of the antenna radiation lobe at 2.45GHz is provided below

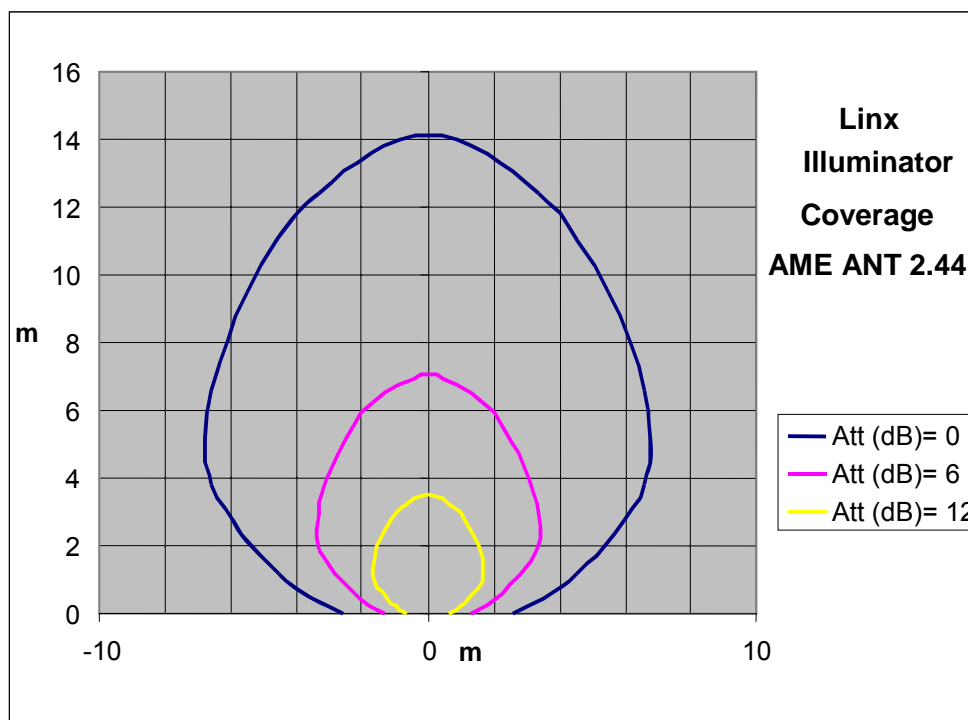

Mechanical Characteristics

<i>Parameter</i>			
External dimensions (L x H x P)	158 mm	95 mm	45 mm
Colour	Ivory RAL 9002		
Degree of protection	IP56		

Wiring for UKOPLX2101FHU

The wiring provides the following connections:

- Power Supply [1]: (12/24V ac, dc) with maximum utilisation power 20W
- RS422 [2]: connection on serial line RS422, to be activated to communicate with other illuminators installed and generate a synchronism in the transmission.

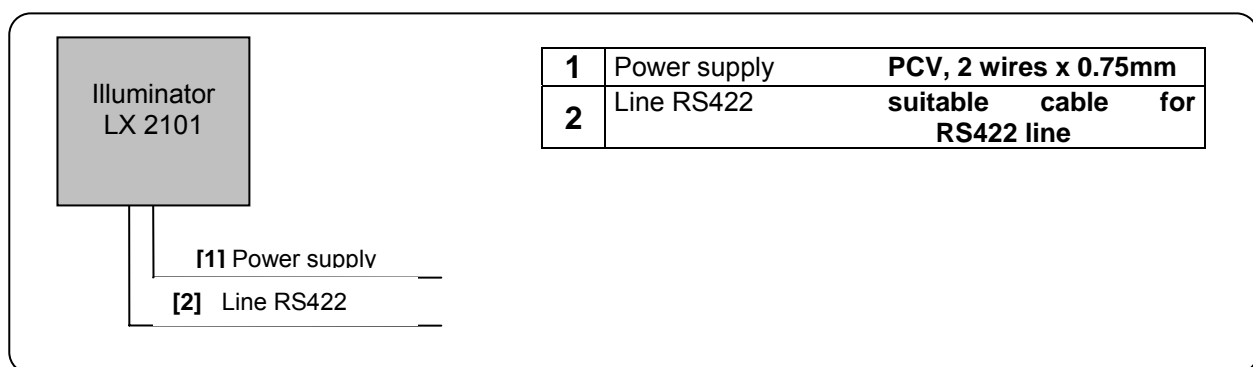
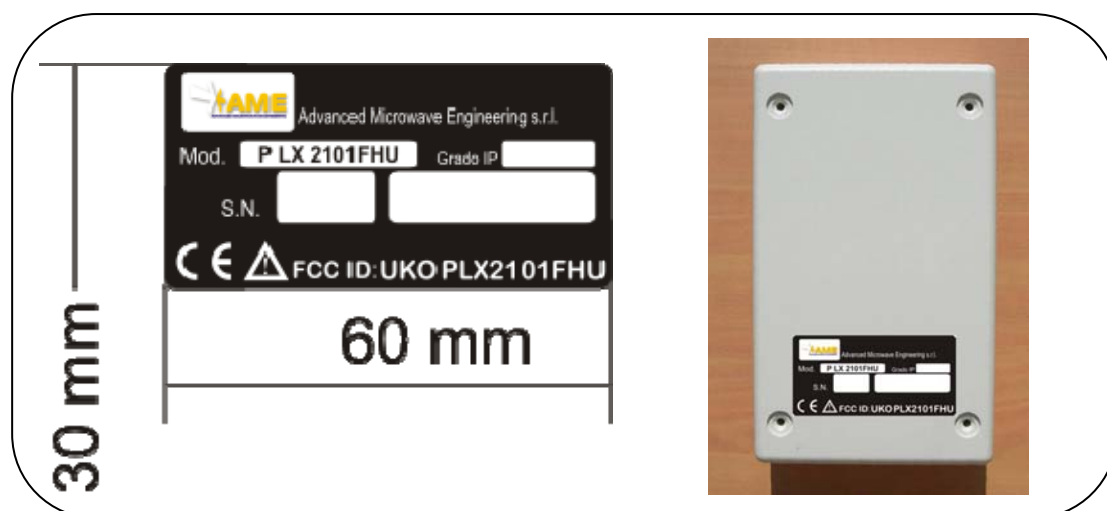

Figure 1: LNX Illuminator Wiring

POSITION OF LABEL



4.2. TAG DualFrequency UKOPLX1004STU & UKOPLX1004QDU



UKOPLX1004ST

Normally off, it activates in the area of influence of the PLX2101FHU illuminator. In reply, it transmits its own code preceded by the code of the illuminator in whose area the TAG was activated, at a reply frequency of 433MHz. Equipped with replaceable lithium battery, it has an endurance of over 100,000 transmissions.

The activation range at 2.45 GHz under the PLX2101FHU illuminator is about 12 meters in free area; the transmission at 433 MHz to the receiver PLX2002, compliant with ETSI EN 300-220, can vary between 40 meters and 60 meters in free area.



UKOPLX1004Q

Mechanical Characteristics

<i>Parameter</i>			
External dimensions UKOPLX1004STU (L x H x P)	95 mm	56 mm	9 mm
External dimensions UKOPLX1004QDU (L x H x P)	52 mm	52 mm	9 mm
Colour	White		

Wiring for UKOPLX1004STU or UKOPLX1004QDU

The system is self-powered and requires no wiring.

POSITION OF LABEL



4.3. UKOPLX2002 Radio Receiver



Radio Receiver (433 MHz) for Dual Frequency TAG
 The device, powered with direct (V_{dc}) or alternating (V_{ac}) 12/24 V voltage, interfaces to the external devices through its communications interfaces, which are a relay and the standard serial communication channels (RS232, RS422 ethernet, wiegand, magstripe). In compliance with ETSI EN 300-220, in this configuration the reception range of the PLX1004STU or PLX1004QDU TAGs can vary between 40 and 60 meters in free area.

The receiver provides for filtering the data receive according to the code of the PLX2101FHU illuminator that activated the transponder.

Mechanical Characteristics

<i>Parameter</i>			
External dimensions (L x H x P)	158 mm	95 mm	45 mm
Colour	Ivory RAL 9002		
Degree of protection	IP56		

Wiring for UKOPLX2002

The wiring provides the following connections:

- Power Supply [1]: (12/24V ac, dc) with maximum utilisation power 20W
- RS232 [2]: connection on serial line RS232, always active
- RS422 [3]: connection on serial line RS422, to be activated
- Magstripe [4]: Magstripe ISO 7811 TRACK 2 connection (standard used by access control peripherals), to be activated
- Wiegand [5]: Wiegand connection, 37BIT protocol (standard used by access control peripherals), to be activated
- TCP/IP [6]: connection to the LAN (NEEDS ADDITIONAL ELECTRONICS; the relevant documentation is not included in the present manual), to be activated
- Service [7]: Relay output, to be activated.
- Tag Present [8]: signals the reception of data from a TAG
- Aux Pwr Sup [9]: (5V dc stabilised) auxiliary power supply line

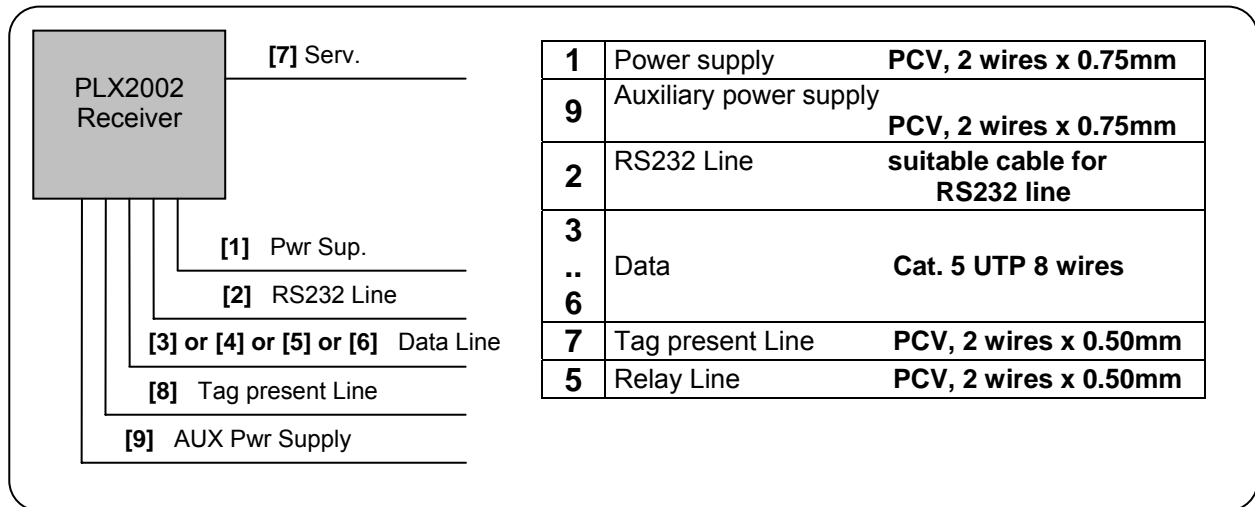
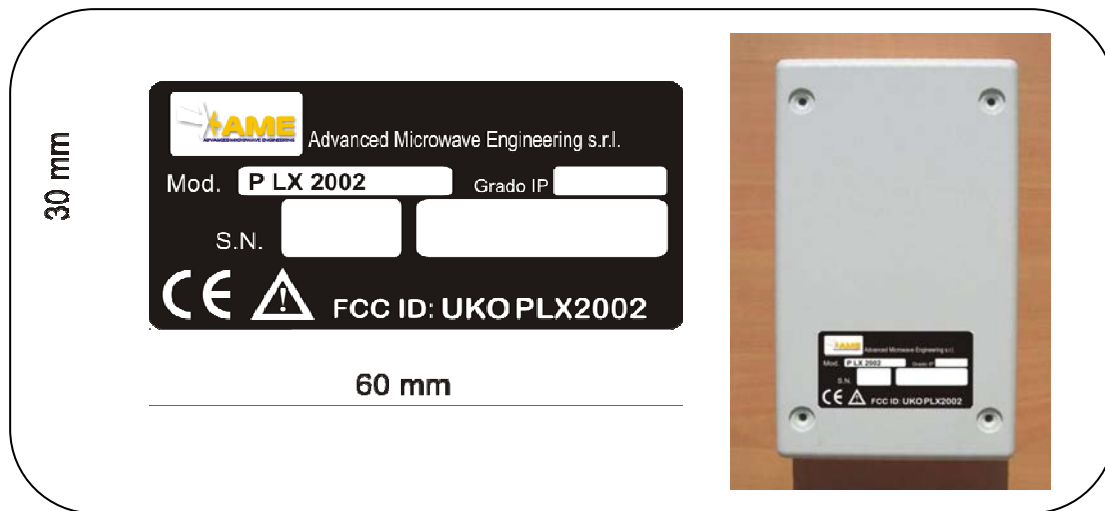

Figure 2: LNX Receiver Wiring

POSITION OF LABEL



5. INSTALLATION

5.1. Introduction

Certain specific functional characteristics are required for the identification system:

Illuminator UKOPLX2101FHU

- ✓ It should be installed according to the following procedures:
 - position it above the centre of the lane to be illuminated, not exceeding 4 metres; otherwise, it may be positioned laterally as shown in the following figure. In this second case, it should be positioned at a height of 2.20 metres to 3.00 metres, orienting it towards the area to be covered by the activation lobe; for the installation, the dedicated bracket can be purchased and used.
 - **it must** be positioned in such a way that there are no obstacles of any kind between the device and the area to be covered by the activation lobe.
 - the devices that will be used will transmit their identifying code which will be received by the transponder; the code will be set during the installation phase using the selectors present on the device.

Note any body (in particular, metal surfaces such as walls, nets, etc.) which comes into the area of influence of the device can interact with the electromagnetic fields produced by the illuminator, generating reflection and attenuation phenomena that can alter the radiation lobe even to a considerable extent.

Receiver UKOPLX2002

- ✓ It should be installed near the barrier. The recommendations to observe are:
 - The device (or alternatively the external antenna) must be positioned in an open environment, in the absence of metal surfaces or reinforced concrete structures, to facilitate the reception of the data sent by the transponders;
 - no transmitter devices with the same working frequencies as the LNX system may be present in the vicinity of the receiving antenna.
 - As an alternative to the antenna integrated internally to the device, an external antenna, not supplied, at 433 MHz – 50 Ω provided with 50 Ω coaxial cable, maximum length 8 metres can be used.

Transponder UKOPLX1004STU or UKOPLX1004QDU

- ✓ it can be installed inside transportation means, or worn by people. Inside transportation means, to obtain the best performance, we recommend to:
 - position the TAG at the centre of the windshield using the adhesive Velcro, in such a way as to make it removable;

- position it on the upper part of the windshield in automobiles and in the lower part of the windshield for lorries;
- not position it behind shield glasses; if the vehicle is fitted with them, the TAG shall be positioned in the areas of the glass not provided with shielding.

Note: the activation range at 2.45 GHz under the Illuminator is about 12 meters in free area; positioning the transponder behind the glass of the vehicle, this range is reduced differently according to the type of glass.

When instead it is worn by people, the following measures shall be observed:

- it has to be “worn” in plain view, preferably with a string around the neck or with a badge holder band secured to the clothes;
- IT MUST NOT be carried in suitcases, bags, clothes pockets;
- IT MUST NOT be placed in contact with other bodies, metallic or otherwise (coins, cell phones, object cases, glass cases, etc...)

5.2. Precautions

Initial Inspection

To avoid electric shock hazards, do not turn the instrument on if it shows signs of damage in any of its parts.



Packing and Unpacking

Check the instruments' shipping package for damages. If it is damaged, retain it until the condition of each individual accessory has been thoroughly checked and the instruments have been checked both mechanically and electrically. Check that the checklist matches the supplied material, including the Documentation. Notify the shipping personnel and Our Servicing Department of any damages.

Preparation for Use

Verify that the power supply system is compliant with current safety standards.



Caution

Before connecting the apparatus to the power supply mains, ensure that the voltage is within $30V_{ac}$.
Before connecting the apparatus to the user's line, ensure that the current that flows through the line in short circuit condition is less than 1° .



Connection to Power Supply Mains



The two apparatuses have an identical power supply system. Each apparatus operates with direct or alternating voltage with a value ranging from a minimum of 12V and a maximum of 24V.

WARNING

The LNX (SELV) power supply system must assure adequate separation from the power supply mains (230 / 110 Vac). On the low voltage line to each individual apparatus must be installed a protecting fuse, rated at 600mA for the power supply, be it at 12V or 24V.

5.3. Technical Characteristics of the Materials Employed

Power supply cord

From the electrical switchboard indicated above starts the electrical power supply cord (recommended model shown in Figure 2 and in Figure 1) for the two apparatuses.

Data cables

For the **receiver**, 4 communication protocols are provided

- ❖ RS232 (Figure 2: LNX Receiver Wiring [2])
- ❖ RS422 (Figure 2: LNX Receiver Wiring [3])
- ❖ Magstripe (Figure 2: LNX Receiver Wiring [4])
- ❖ Wiegand (Figure 2: LNX Receiver Wiring [5])
- ❖ TCP/IP (Figure 2: LNX Receiver Wiring [6])

Based on the implementation requirements Figure 2, the characteristics of the respective cables are indicated.

For the **illuminator**, the RS422 is provided for connection with one or more illuminators.

The interconnection allows to synchronise the transmission of the various apparatuses.

Auxiliary cables

Two auxiliary outputs are provided on the receiver:

- ❖ Relay (Figure 2: LNX Receiver Wiring [7])
- ❖ Tag Present (Figure 2: LNX Receiver Wiring [8])

Both lines are activated in the presence of a TAG, but as the section dedicated to the programming of the Receiver clearly specifies, they have independent settings.

The type of signal they generate is very important; the Relay output manages a **power signal**, while the TAG present output manages a **digital signal**.

Environmental conditions

These apparatuses are specified to operate within the following limits:

MAX Temperature: 60°C

Humidity: MAX 95% non condensing

Installation: the apparatus is immune to indirect water splashes

These apparatuses must be stored in a clean, dry environment. Storage and transports are specified with the following environmental limits: temperature, humidity, elevation.

Cleaning the instrument

Use a clean, non abrasive, soft and dry cloth.

Caution

To clean the apparatuses, do not use any solvent, dilutant, turpentine, acid, acetone or similar materials, to avoid damaging the outer case.

5.4. Notes on Installation

Installation

To install the LNX apparatuses, carefully follow the instructions contained in the following paragraphs.

Equipment required for installation

- ❖ Medium sized Phillips head screwdriver
- ❖ Small screwdriver (for watch makers)
- ❖ Electrician's scissors
- ❖ Wire stripper
- ❖ Drill
- ❖ Tester
- ❖ Conical tip, min \varnothing 25 mm
- ❖ All materials useful for fastening the apparatuses to a wall

Notes on installation

Depending on the degree of protection to be reached, a different type of installation is required.

IP55: Using a ducting system made up of corrugated tube (recommended model GEWISS DX 30 320) and nut union fitting (recommended models GEWISS DX 54 420 with DX 54 520) it is possible to achieve the IP55 Degree of Protection, i.e. rain-proofing.

A similar level of protection is obtained using the sealed cable duct (recommended model GEWISS GW 52 042), provided that only one cable passes inside the duct.

Caution



A fundamental condition to achieve and maintain the degree of protection selected for the installation is that every time the lid is removed, it is repositioned correctly with the gasket in the proper position and free of damages or twists which could cause water infiltrations.

5.5. Installation of the Apparatus

The procedure to follow to install the two apparatuses of the system is identical and it comprises 7 steps:

- a) Preparation of the electrical system
- b) Drilling holes in the boxes
- c) Fastening the boxes or the joint (if provided)
- d) Laying the power supply cords
- e) Laying the data cables
- f) Housing the apparatuses
- g) Initialising the system
- h) Tests and checks

Preparation of the electrical system

Usually, the power supply system comprises a magnetothermic breaker, 500 mA fuse with FAST action and SELV 200V/24V mains transformer, all within an electrical switchboard that may be dedicated or incorporated in a general one.

Drilling holes in the boxes

The recommended mounting methods have already been described; for the illuminator apparatus, often connected only to the power supply, cable duct mounting is recommended (see Figure 4: mounting with cable duct).

For the receiver apparatus, connected to multiple wires, wiring with corrugated hose and junction is recommended (see Figure 3: mounting with corrugated hose).

The dimensions of the junction and of the cable duct depend on mounting requirements.

If mounting is completed correctly, this type of wiring guarantees the degree IP55



Figure 3: mounting with corrugated hose



Figure 4: mounting with cable duct

Fastening the boxes

The apparatus can be fastened directly to the wall with adhesives, or through four tabs (not supplied) for fastening in the way that best suits the support structure (e.g.: Fischerr for wall, self-threading screws for metals, suitable screws for wood, etc.)

A joint (not supplied) can be used, allowing to orient the apparatus after mounting (Figure 5: fastening articulated joint).



Figure 5: fastening articulated joint

Laying the power supply cords

Connect the power supply cord from the electrical switchboard to the apparatuses. Let 15 cm of cord project outside the box and connect the 2-pole female terminal, included in the supply.

Illuminator Power Supply

Supply power to the device by means of the J1 screw connector positioned on the left side; it is possible to supply both direct voltage Vdc and alternating voltage Vac with voltage value 12V or 24V. It is not important to match terminal polarity.

The red LED indicates the correct operation of the device.

Receiver Power Supply

Supply power to the device by means of the J1 screw connector positioned on the left side; it is possible to supply both direct voltage Vdc and alternating voltage Vac with voltage value 12/24V. It is not important to match terminal polarity.

Receiver Auxiliary Power Supply

Pin 2 of the connector J6 (+5V Vdc) can be used to power the device by means of stabilised direct voltage at 5 V.

V_{max} = 5 V continuous stabilised

⚠ **NOTE:** Make absolutely sure that pin 3 of the connector J6 (GND) is used as reference.

⚠ **NOTE:** the input line is NOT protected; use a stabilised reference voltage.

⚠ **NOTE:** DO NOT simultaneously power the board using the supplementary input at 5 Vdc and the standard power supply of the connector J1

Check voltage levels with a TESTER.

Laying the data cables

Based on the type of connection selected for the receiver (see paragraph “

Wiring for UKOPLX2002”) connect the data cable to a PC if RS232, or to the network access point if LAN or RS422.

For easier maintenance, each individual wire should be labelled.

Verify the Intranet connection through the LAN data cable.

WARNING: DO NOT CONNECT THE APPARATUS TO THE LAN NOW

Laying the auxiliary cables

Laying the auxiliary cables.

RELAY: Let 10 cm of cord project outside the box and connect the 12-pole female terminal, included in the supply; based on the position, operation will be as follows.

❖ 11 – 12 : *NORMALLY OPEN* operation

❖ 10 – 11 : *NORMALLY CLOSED* operation

Opening and delay times can be set via software

Verify the connection short-circuiting, or opening the line and checking whether the expected operation is performed.

TAG PRESENT: Let 10 cm of cord project outside the box and connect the terminals, one to pin 3 of the 12-pole female terminal and one to pin 3 of the 4-pole connector, included in the supply

Housing the apparatuses

House the apparatuses, securing them with the supplied screws as shown in Figure 6: receiver apparatus and Figure 7: illuminator apparatus



Figure 6: receiver apparatus



Figure 7: illuminator apparatus

Closing the lids

Position the o-ring inside the groove,
position the gaskets to the screws,
fasten the lid with the screws.

5.6. Starting the apparatuses

Start

To set up the LNX apparatuses, carefully follow the instructions contained in the following paragraphs.

Equipment required for starting

- ❖ PC with DRS232 port, or USB (use a commercial USB-RS232 converter)
- ❖ Serial cable

5.7. Configuration of illuminator UKOPLX2101FHU

This device is an activator for 2.45 GHz transponders active in the LINX system, which not only generates a carrier at the preset frequency but transmits data according to the parameters set.

The device also generates synchronization commands for other PLX2101FHU devices set as slaves, so as to form a network providing more specific radio coverage.

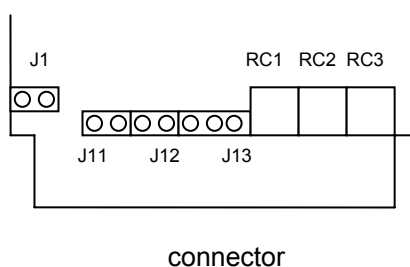

Power supply

Hook the device up to the power supply using the special threaded connector J1 placed on its left side; it can be powered with 12/24 V voltage, both DC and AC. The polarity of the electric terminals is not relevant.

The red led indicates correct operation of the device

External interface

The device has an external RS422 interface (*not* terminated with a 120 Ω resistor) used for both programming its own identification code as an external unit, and for transmitting/receiving synchronization commands to/from other PLX2101FHU connected to the network.

On connector J11, pins 1 and 2 (Tx+, Tx-) are lines “Tx+” and “Tx-“ of the RS422 serial interface (RS485 full duplex); on connector J12, pins 1 and 2 (Rx+, Rx-) are lines “Rx+”, “Rx-“ of the RS422 serial interface (RS485 full duplex).

⚠ NOTE: The use of connectors J10 and J13 is reserved for factory testing procedures, and we recommend that NO external electric signal be interfaced.

⚠ NOTE: for network connections, refer to the paragraph on “Operating Modes”.

Operating modes

3 different operating modes are possible:

1. Standalone master (SA master)
2. Piconet master (PN master)
3. Slave

The device is unequivocally identified by the 3-byte factory code (F.C.).
 These 3 different modes permit 3 different installation configurations:



Up to 32 readers can be networked, all managed by the host using addressable protocol. Each device can be programmed independently.

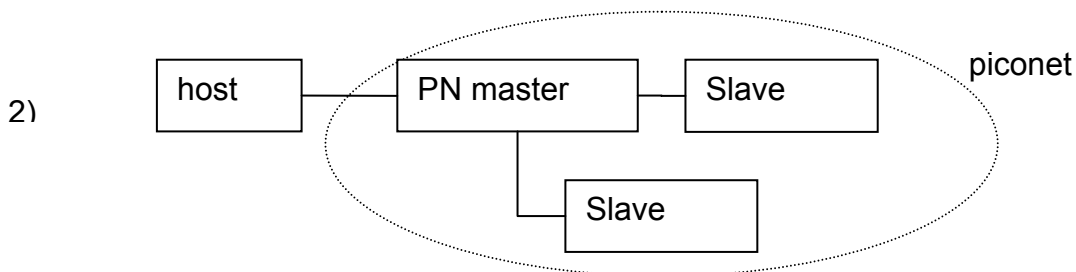

The host can manage a single piconet made up of 1 Master pn and up to 31 Slaves. The settings transmitted to the Master are automatically extended to the connected slaves.

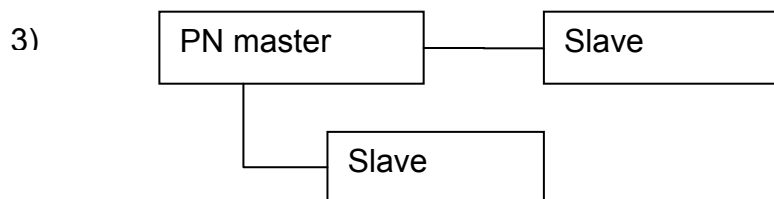

The piconet is stand alone and NOT connected to a host. The settings made to the master are automatically extended to the connected slaves.

Set the operating mode with the SW1 dipswitch at the top of the board.

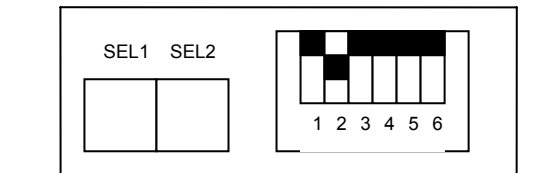

SW1 dipswitch details

Selector	Position 0 (down)	Position 1 (up)
1	Slave	Master
2	External	Internal
3	Line 1 (tx in antiphase with master)	Line 0 (tx in phase with master)
4	Duty cycle transmission	Continuous transmission
5	SW parameters	HW parameters
6	PN master	SA master

To make the settings effective the device must be reset.

Selector 1: by pushing up the switch, the device is set as Master (ON); when turned on, it sends its identification code over the RS422 interface, and after a few seconds the synchronization commands of any other LX2101 devices connected in slave mode. In this configuration, switches 2 and 3 become irrelevant. By pushing down the switch (OFF), the device is set as Slave and transmits only when it receives the synchronized command sent over the RS422 interface by a reader set as Master. In this configuration, switches 2 and 3 become operative.

Selector 2: if pushed up (ON), the device transmits the identification code with the suffix "I" (Internal); if pushed down (OFF) the device transmits the identification code with the suffix "E" (External).

NOTE: if the device is set as Slave, the device transmits the identification code of the Master unit which manages the RS422 network .

Selector 3: active only if the device is set as Slave; if pushed up (ON), the device transmits in phase (simultaneously) with the Master unit which manages the RS422 network; if pushed down (OFF) it transmits in antiphase (alternating) with the Master unit.

Selector 4: active only if the device is set as Master; if pushed up (ON), it allows continuous transmission of data; otherwise, if pushed down (OFF) it allows discontinuous transmission (one code in each factory set time interval) of the identification code.

⚠ NOTE: if continuous transmission of the code is activated (ON), the Master device NO LONGER manages the synchronization of any other devices connected as slaves through the RS422 interface.

Selector 5: active only if the device is set as Master; if pushed up (ON), the device transmits the parameters set by the RC1, RC2, RC3, Sel1 and Sel2 selectors;

otherwise, if pushed down (OFF) the device transmits via radio channel the parameters set by the commands on the serial RS422 interface (See “Binary communication protocol”)

Selector 6: active only if the device is set as Master; if pushed up (ON), the device does not manage any slave devices connected to it, and moreover, responds only to the binary protocol commands on the RS422 interface addressed to it; if pushed down (OFF), the Master device manages the connected piconet and transmits operating parameters to its Slave devices.

⚠ NOTE: all changes to settings become operative after the device is reset (see "button functions" below)

Button functions

When pushed down, the SW2 button has different functions according to how it is pressed:

- Pressed for under 3 seconds: resets the receiver, as if it were turned off and back on
- Pressed for over 3 seconds: the device transmits its own diagnostics data via radio to the transponder.

LEDs

LED1 (D10): always lighted, it indicates correct power supply to the board

LED2 (D11): when flashing, indicates transmission at microwaves (phase Master/Slave line 0)

LED3 (D7): when flashing, indicates transmission at microwaves of the slave line1 (antiphase Master)

LED4 (D8): lighted when carrier frequency is locked

LED5 (D9): when flashing, indicates the transmission/receive on RS422 channel

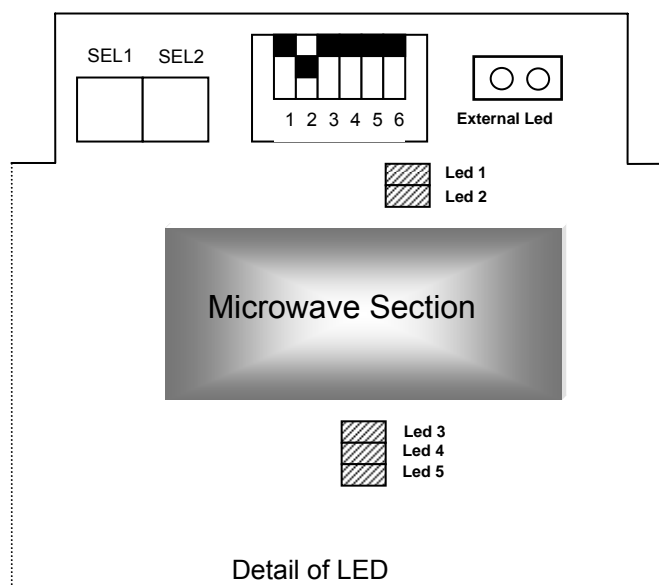

Led	Function
1	Power-On
2	Master/Slave0 Tx
3	Slave1 Tx
4	Lock Frequency
5	RS422 Tx/Rx
External	Master Tx

LED's Table

* Active only in "Master" configuration.

Reader Code

The RC1, RC2, RC3 rotary codes on the bottom right allow the serial number (S.N.) of the device to be set.

This code is transmitted only if selector 5 on the SW1 dipswitch is pushed up (ON).

1. RC1 (x100): sets the hundreds in the code to be transmitted
2. RC2 (x10): sets the tens in the code to be transmitted
3. RC3 (x1): sets the units in the code to be transmitted

 **NOTE:** To make the settings operative, press the reset button.

Product Code

The SEL1 and SEL2 rotary codes on the top left allow one to set the product code to be transmitted to the transponder.

This code is transmitted only if selector 5 on the SW1 dipswitch is pushed up (ON).

1. SEL1 (x10): sets the tens in the code to be transmitted
2. SEL2 (x1): sets the units in the code to be transmitted

For more details on the operating modes, refer to the documentation on the CAP "5.8 Configuration of trasponder UKOPLX1004STU / UKOPLX1004QDU".

 **NOTE:** To make the settings operative, press the reset button.

Binary communication protocol

The device can be completely controlled and parameterized through the RS422 serial interface, and all packets are addressed using the factory code (F.C.)

Communication is made through a predefined data format, as follows:

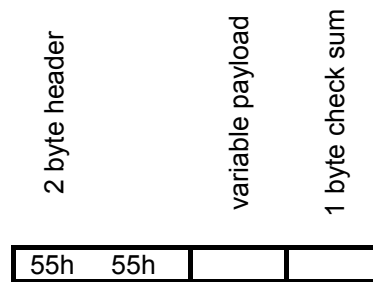

In the entire packet the order of the bytes within the words is LSB-MSB.

The check sum (CS) is calculated as module 2 (XOR) of the PAYLOAD.

Payload

The length of the payload is variable and depends on the command it refers to.

COMMAND	PARAMETERS
1	N

The command set is:

	Code (decimal)	Description	Parameters	Parameter length (bytes)	Note
Commands from host to device	1	Set S.N.	F.C. + S.N.	3+2=5	
	2	Get S.N.	F.C.	3	
	3	Not implemented	-	-	
	4	Get duty cycle	F.C.	3	
	5	Not implemented	-	-	
	6	Not implemented	-	-	
	7	Not implemented	-	-	
	8	Not implemented	-	-	
	9	Set product code	F.C.+product code	3+1=4	
	10	Get product code	F.C.	3	
	11	Get dipswitch settings	F.C.	3	
	12	Microwave power on	F.C.	3	
	13	Microwave power off	F.C.	3	
	14	Get microwave supply status	F.C.	3	
Commands from device to host	15	Ack	F.C.	3	
	16	Nack	F.C.+error code	3+1=4	
	17	TX S.N.	F.C.+S.N.	3+2=5	
	18	TX duty cycle	F.C.+d.c.	3+2=5	
	19	TX power	F.C.+power.	3+1=4	4 bit lsb
	20	TX frequency	F.C.+frequency	3+1=4	4 bit lsb
	21	TX product code	F.C.+product code	3+1=4	
	22	TX dipswitch settings	F.C.+settings	3+1=4	
	23	TX microwave supply status	F.C.+status	3+1=4	
Commands from device to device	24	Initialization	S.N.+product code+power/frequency	2+1+1=4	Power = 4 bit msb Frequency = 4 bit lsb
	25	TX Slave 0	no. of packets to transmit	1	
	26	TX Slave 1	no. of packets to transmit	1	
* the power transmission is NOT implemented, therefore this data does not have validity					



NOTE:

F.C. = individual device factory code

S.N. = Serial Number which the device transmits for its identification

CMD 01

Allows one to set the Serial Number (S.N.) to be transmitted via radio:

S.N.
2

in which

- S.N.: number between 0 and 999, including the Internal or External suffix.

bit 11	Meaning
0	S.N. INTERNAL
1	S.N. EXTERNAL

CMD 02

Requests the serial number currently set. The device may respond by transmitting the S.N. (CMD 17) or a NACK (CMD 16)

CMD 03

NOT IMPLEMENTED

CMD 04

Requests the transmission duty cycle currently set. The device may respond by sending the duty cycle (CMD 18) or a NACK (CMD 16)

CMD 05

NOT IMPLEMENTED

CMD 06

NOT IMPLEMENTED

CMD 07

NOT IMPLEMENTED

CMD 08

NOT IMPLEMENTED

CMD 09

Allows one to set the product code to be transmitted via radio:

<i>Product Code</i>
1

in which

- Product Code: number between 0 and 99.

CMD 10

Requests the product code currently set. The device may respond by transmitting the product code (CMD 21) or with a NACK (CMD 16)

CMD 11

Requests the settings of the SW1 dipswitch. The device may respond by transmitting the settings (CMD 22) or with a NACK (CMD 16)

CMD 12

Requests activation of radio communication, activating communication with the Lx1004 transponder. The device may respond with an acknowledge (CMD 15) or with a NACK (CMD 16). If the radio section is power off, the device reset itself.

CMD 13

Requests that radio communication be turned off, deactivating communication with the Lx1004 transponder. The device may respond with an acknowledge (CMD 15) or with a NACK (CMD 16)

CMD 14

Requests the status (on or off) of radio transmission. The device may respond by transmitting the status (CMD 23) or with a NACK (CMD 16)

CMD 15

The device sends an ACK each time a command is correctly carried out

CMD 16

The device sends a NACK each time a command is NOT correctly carried out, continuation from the code error.

Command	Error	Error Code
ALL	Checksum	1
1÷14	Command for Master	2
1	S. N. out of range	3
1,9	Setting Hardware Code	4
3	Not Possible set Duty-Cicle	5
7,8	Not Possible set Frequency	7
9	Cod.Prod. out of Range	8

CMD 17

The device transmits its own Serial Number (S.N.):

S.N.
2

in which

- S.N. number between 0 and 999, including the Internal or External suffix.

bit 11	Meaning
0	S.N. INTERNAL
1	S.N. EXTERNAL

CMD 18

The device sends the current duty cycle for frame transmission.

No. of frames to transmit	Latency
1	1

in which

- No. of frames to transmit: number of frames that must be sent in each transmission
- Latency: time interval between transmissions (as a multiple of 200mseconds)

CMD 19

NOT IMPLEMENTED

CMD 20

The device sends the frequency of the radio transmitter; the operating frequency can be selected out of 16 possible options:

Frequency
1

The lowest 4 bits indicate the operating frequency set.

CMD 21

The device sends the product code transmitted via radio:

Product Code
1

in which

- Product Code: number between 0 and 99.

CMD 22

The device sends the current dipswitch settings:

Dipswitch settings
1

in which

- SETTING bit definition:

BIT0 - Selector 1: 0 (down) OFF; 1 (up) ON
 BIT1 - Selector 2: 0 (down) OFF; 1 (up) ON
 BIT2 - Selector 3: 0 (down) OFF; 1 (up) ON
 BIT3 - Selector 4: 0 (down) OFF; 1 (up) ON
 BIT4 - Selector 5: 0 (down) OFF; 1 (up) ON
 BIT5 - Selector 6: 0 (down) OFF; 1 (up) ON
 BIT6 - N.U.
 BIT7 - N.U.

CMD 23

The device transmits the current status of power supply to the radio unit:

Power supply status
1

in which

- Power supply status: 0 (down) OFF; 1 (up) ON.

TEMPORAL DIAGRAM FOR CONFIGURATIONS NET

a) Standalone master

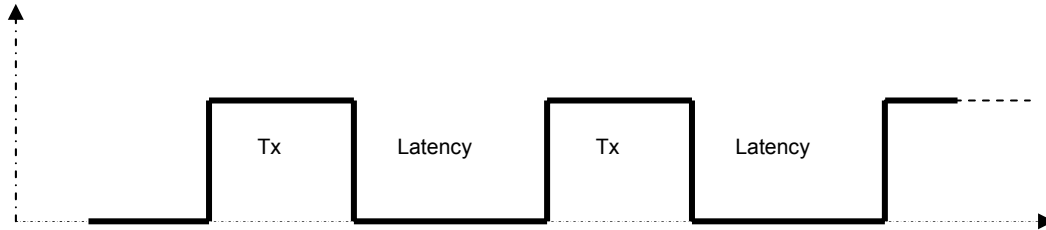

Master Stand Alone

b) Piconet Master & Slave

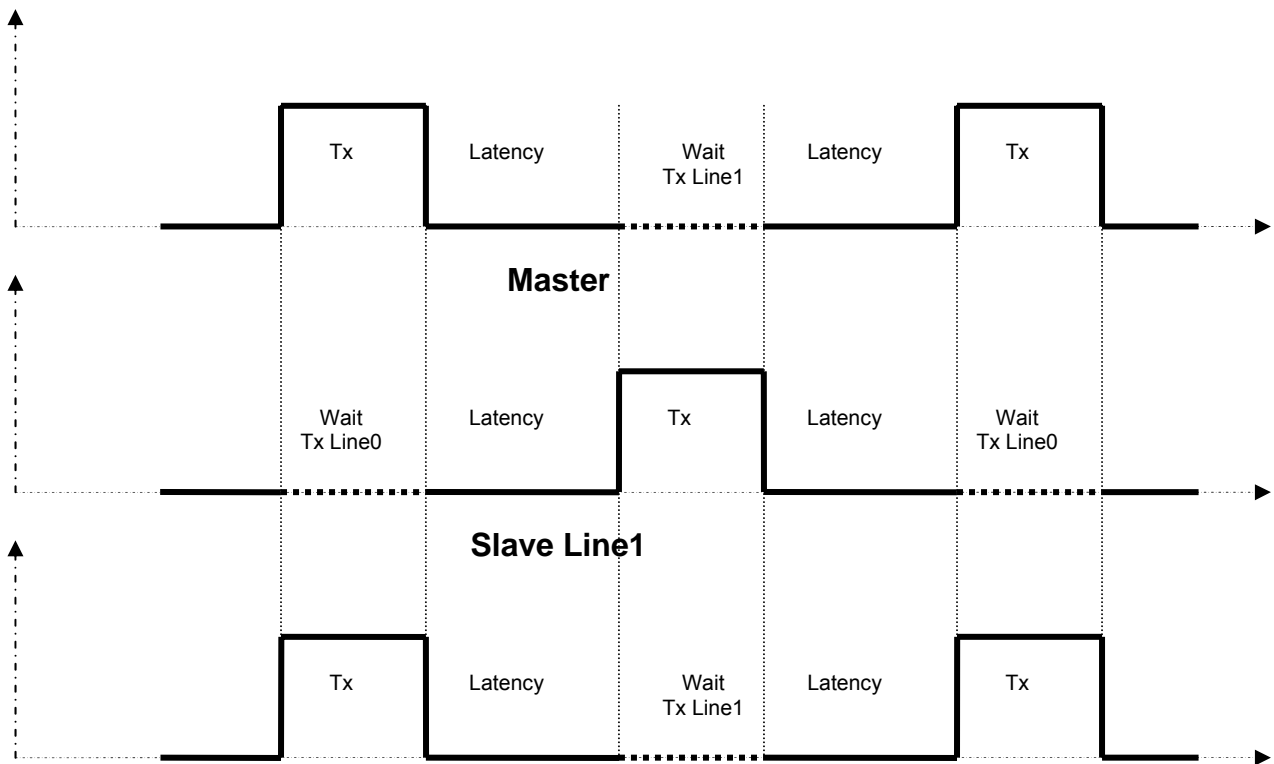

Slave Line0

Time Latency is 200msec.

Time Tx is 500msec

5.8. Configuration of trasponder UKOPLX1004STU / UKOPLX1004QDU

Introduction

PLX1004STU and PLX1004QDU are an active dual-layer transponder, which upon activation by a 2.45 GHz carrier can receive data from a reader (uplink) and transmit its own 32-bit ID code, followed by other data (downlink).

Compatible with the readers in the AME product line and with the PLX2002 receiver.

Versions available

PLX1004STU and PLX1004QDU have the same electrical, radio and operational properties but different package and mechanical characteristics.

Operating mode

The operating mode is dictated by the product code transmitted by the PLX2101FHU activator.

During normal operation, the transponder memorizes two pieces of data:

1. number of transmissions made
2. number of resets carried out

and then it transmits this information as follows:

1. every 1000 transmissions
2. when requested by the specific reader which transmits the product code of the tag diagnostics.

After receiving the data transmitted by the reader, the device sets the correct operational parameters and configures itself according to the selected mode .

The various operating modes are listed below:

Code (decimal)	Operation mode description
1	STANDARD (3 tx+psr ₍₁₎ 200 msec+2 sec+2 tx+pausa 2 sec) (see note 1)
2	FAST (3 tx + psr 45 msec+450 msec) (see note 1)
3	APB (3 tx + psr 2 sec+2 tx + apb ₍₂₎ 1 sec)
4	APB (3 tx + psr 2 sec+2 tx + apb 2 sec)
5	APB (3 tx + psr 2 sec+2 tx + apb 3 sec)
6	APB (3 tx + psr 2 sec+2 tx + apb 5 sec)
7	APB (3 tx + psr 2 sec+2 tx + apb 10 sec)
8	TRACK
9	ECM
10	<i>Not allowed</i>
...	...
58	<i>Not allowed</i>
59	BEEPER FAST ($\Delta t=15'$; T _{Operation} =1h) (see note 1)
60	BEEPER FAST ($\Delta t=15'$; T _{Operation} =3h) (see note 1)
61	BEEPER FAST ($\Delta t=15'$; T _{Operation} =10h) (see note 1)
62	BEEPER FAST ($\Delta t=15'$; T _{Operation} = non stop) (see note 1)
63	BEEPER FAST ($\Delta t=30'$; T _{Operation} =3h) (see note 1)

64	BEEPER FAST ($\Delta t=30'$; TOperation=5h) (<i>see note 1</i>)
65	BEEPER FAST ($\Delta t=30'$; TOperation=10h) (<i>see note 1</i>)
66	BEEPER FAST ($\Delta t=30'$; TOperation= non stop) (<i>see note 1</i>)
67	BEEPER FAST ($\Delta t=60'$; TOperation=5h) (<i>see note 1</i>)
68	BEEPER FAST ($\Delta t=60'$; TOperation=10h) (<i>see note 1</i>)
69	BEEPER FAST ($\Delta t=60'$; TOperation=15h) (<i>see note 1</i>)
70	BEEPER FAST ($\Delta t=60'$; TOperation= non stop) (<i>see note 1</i>)
71	BEEPER FAST ($\Delta t=90'$; TOperation=5h) (<i>see note 1</i>)
72	BEEPER FAST ($\Delta t=90'$; TOperation=10h) (<i>see note 1</i>)
73	BEEPER FAST ($\Delta t=90'$; TOperation=15h) (<i>see note 1</i>)
74	BEEPER FAST ($\Delta t=90'$; TOperation= non stop) (<i>see note 1</i>)
75	BEEPER FAST ($\Delta t=60$ s; TOperation=non stop) (<i>see note 1</i>)
99	TAG Diagnostic



NOTE 1 : IMPORTANT

“Standard”, “Fast” and “beeper fast” operation (code 1,2 and 59 to 95) of AME UKOPLX1004STU and UKOPLX1004QDU are allowed ONLY in applications involving fire, security or safety of life (please refer 15.231 (a) (4)).

- (1) P_{sr}=pseudorandom
- (2) ap_b=anti passback

Description of various operating phases (symbols)

- Tx: radio transmission at 433 MHz.
- P_{sr}: variable time interval calculated in pseudorandom mode, during which the device is inactive
- Pause: fixed time interval during which the device is inactive
- ap_b: time interval during which the device remains inactive if it continues to receive the same information

STANDARD mode.

IMPORTANT:

“standard mode” is allowed only in fire, security or safety of life applications. For example applications where the PLX2101FHU activator is near a dangerous zone for safety of life.

Upon receiving a code from the activator PLX2101FHU, TAG transmit data to PLX2002 receiver. Transmission cycle is composed by 3 tx+psr (200 msec÷2 sec) +2 tx + 2 sec pause). After each transmission cycle, TAG wait for 2 seconds before a new receiving is allowed .

FAST mode

IMPORTANT:

“fast mode” is allowed only in fire, security or safety of life applications. For example applications where the PLX2101FHU activator is near a dangerous zone for safety of life.

Upon receiving a code from the activator PLX2101FHU, TAG transmit data to PLX2002 receiver. Transmission cycle is composed by 3 tx + psr (45 msec+450 msec) for a maximum transmission time of 600msec:

Mode		Total transmission time max (ms)
Standard	3Tx (150ms) + PSR (max 2s) + 2Tx(100ms)	2250
Fast	3Tx (150ms) + PSR (max 450ms)	150
APB	3Tx (150ms) + PSR (max 2s) + 2Tx(100ms)	2250
Track	3Tx (150ms)	150
ECM	3Tx (150ms) + PSR (max 2s) + 2Tx(100ms)	2250
Beeper	3Tx (150ms)	150
	NOTE: Tx: packet transmission time (50 ms)	

After each transmission cycle, TAG wait for variable time (45ms-450ms) before a new receiving is allowed .

APB mode

Upon receiving a code from the activator PLX2101FHU, TAG transmit data to PLX2002 receiver. Transmission cycle is composed by 3 tx+ psr (200 msec+2 sec) +2 tx) for a total maximum transmission time of about 2,5sec . A new receiving and a following transmission cycle will be allowed only if the TAG will not be in the activation field of the same PLX2101FHU for a defined APB time.

TRACK mode

Upon receiving a code from the reader, the counter is activated and increments each second; when the device ceases to receive this code for more than 3 seconds, or when it receives a different code, it transmits its own f.c. and the counter total

⚠NOTE: in this modality, for a greater optimization of the consumptions, the device is placed in reception every second, therefore for facilitate the reception is advised to use illuminators PLX2101FHU in modality of continuous transmission

ECM mode

When the first activation code is memorized, the device transmits when it receives an activation signal with the same code, but with a different suffix (Internal /External), or when it does not receive anything for 3 seconds. During this time, if it mainly continues to pick up the same activation code (Internal or External), the count is continuously updated. If after receiving the first code it picks up a different one, it transmits a probable relay signal, memorizes the code received, and starts the cycle over from the beginning

The coding is:

CODING	VALUE
00	Input
01	Output
02	Prob. Input
03	Prob. Output

BEEPER FAST mode

IMPORTANT:

:**beeper fast** is allowed only in fire, security or safety of life applications, for determine integrity of transmitters

When the product code has been sensed, the device transmits at regular intervals (Δt) until the end of the time period ($T_{Operation}$), or until it locates a reader with a product code of the same series and with the code 999I or 999E

If it locates a reader with a product code of the same series, it modifies the settings of the beeper mode; if it locates a reader with a product code different from the last code received, it immediately changes its operating parameters.

5.9. Configuration of receiver UKOPLX2002

The PLX2002 reception unit (also referred to as receiver or BOA RF) is a control centre whose operating modes can be programmed and parametrized.

The receiver is in permanent reception of data transmitted by the transponders via radio, and on receiving valid data transmits them to external units over the communication interfaces set up.

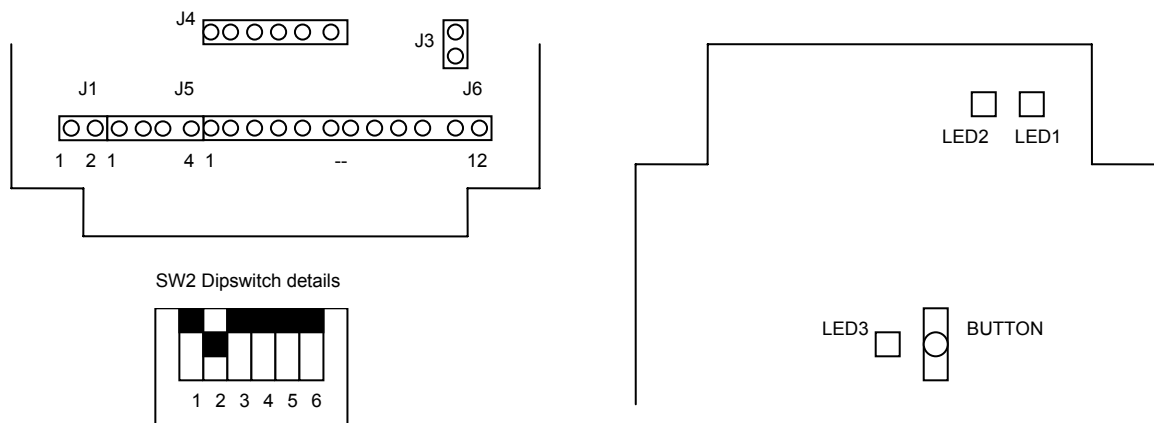

Selet. 1	Selet. 2	Selet. 3	Selet. 4	Selet. 5	Selet. 6
ETHERNET	MAGSTRIPE2/ WIEGAND2	WIEGAND1	MAGSTRIPE1	RS-485	RELAY

It is equipped with a programmable internal clock so that the date and the hour of reception are recorded for each transponder code (when selected).

Supplementary power supply

Pin 2 of connector J6 (+5 V DC) can be used to power the device with continuous stabilised 5 V current.

V_{max} = 5 V continuous stabilized current

- ⚠ **NOTE:** Be very careful to use pin 3 of connector J6 (GND) as a reference
- ⚠ **NOTE:** the supply line is NOT protected; use a stabilised voltage reference
- ⚠ **NOTE:** do NOT power the board using the alternate 5 DC input line and the standard connector J1 power supply network at the same time

External interface

The device has multiple electric communications interfaces for external peripherals.

Relay: pins 10, 11, and 12 (NCL, COM, NOP) on connector J6 correspond to the "normally closed", "common", and "normally open" outputs of the relay on the side of the device. This interface can be activated or deactivated by pushing switch 6 of SW2 up (ON) or down (OFF), as shown on the diagram.

RS232: pins 3, 4, and 5 on connector J6 (GND, Rx, Tx) are, respectively, the "ground", "Rx", and "Tx" signals of the standard serial interface. This interface is usable only when the device is operating in Stand Alone mode, whereas in networking mode, the information is not transmitted. Data are transmitted in ASCII mode (see ASCII data format).

RS485: pins 6, 7, 8, and 9 (Tx-, Tx+, Rx-, and Rx+) on connector J6 are lines "Tx-", "Tx+", "Rx-" and "Rx+" of the RS485 serial interface.
If activated through switch 5 on SW2, data are transmitted in the form of an ASCII string (See ASCII data format).

⚠ NOTE: This interface is NOT managed as an addressable multipoint serial interface, and an anti-clash protocol is NOT provided for access to the data bus. For the addressable multipoint operating mode, see the paragraph on "RS485 NETWORKING operation"

If the cables are particularly long, it may be necessary to terminate the farthest receiver with two external 120 Ω resistors to be positioned on the connector between pins 6 and 7 and between pins 8 and 9.

Ethernet: this interface is an alternative to the RS485 interface.

If activated using switch 1 on SW2, data are transmitted in the form of an ASCII string (See ASCII data format).

With this interface is enabled also the binary protocol (see binary protocol in Networking configuration), made exception for the clearing of the memory buffer.

⚠ NOTE: if the device is asked to clear all memory buffer through the binary protocol, it answers with NACK, because the management of the memory is possible single in the Networking configuration.

⚠ NOTE: If activated using switch 1 of SW2, the RS485 interface MUST be deactivated by pushing down (OFF) switch 5 on SW2 (see Networking configuration)

⚠ NOTE: for the configuration of ethernet operating parameters, refer to the relevant instruction manual.

Tag Present (TP): on connector J5, pin 4 (T.P.) and pin 3 (GND) of connector J6 define the TTL open collector interface used to indicate reception of a correct transponder code. The line is activated for a preset time and CANNOT be deactivated.

Wiegand1: on connector J5, pins 1(D0) and 2 (D1), and pin 3 (GND) of connector J6 determine the standard Wiegand HID10302 37-bit interface (first LOW and then HIGH) in which the first 32 bits are the Tag Code Number

This interface can be activated through switch 3 on SW2.

⚠ NOTE: Wiegand1 interface and Magstripe1 interface cannot at the same time be activated

Wiegand2: on connector J4, pin 2(D4), pin 3 (D5) and pin 4 (GND) determine the standard Wiegand HID10302 37-bit interface (first LOW and then HIGH) in which the first 32 bits are the Tag Code Number

This interface can be activated through switch 2 on SW2.

⚠ NOTE: Wiegand2 interface can be activated only if Wiegand1 interface is activated .

⚠ NOTE: The Wiegand2 port, if activated, transmits only data from transponders activated by the PLX2101FHUs which are set as external, in which case the Wiegand 1 port transmits only data from transponders activated by readers set as Internal (lsb to msb):

Magstripe1: on connector J5, pins 1(D0), 2 (D1), 3 (D2) and pin 3 (GND) of connector J6 are used for data transmission in ISO7811 TRACK 2 format (lsb to msb):

D0	DATA
D1	CLK
D2	STROBE

The data transmitted are divided into two packets totalling 26 bytes.
The 15 bytes of PAN information contain:

		PAN 15		
Tag F.C.	Reader F.C.	Product Code	NULL	
9	3	2	1	

The 11 bytes of ADDITIONAL DATA contain additional information on the receiver:

ADDITIONAL DATA (11)	
Receiver S.N. (5 digits)	NULL
5	6

If the PLX2101FHS reader which has activated the transponder is External (“E”), the data are transmitted in the opposite direction (msb to lsb) as compatible with the ISO7811 TRACK 2 standard.

This interface can be activated through switch 4 on SW2.

⚠ NOTE: the Wiegand1 interface and Magstripe1 CANNOT be simultaneously activated

Magstripe2: on connector J4, pins 1(D3), 2 (D4), 3 (D5) and pin 4 (GND) are used for the transmission of data in the ISO7811 TRACK 2 format (lsb to msb):

D3	DATA
D4	CLK
D5	STROBE

the data transmitted are divided into two packets totalling 26 bytes.
The 15 bytes of PAN information contain:

		PAN (15)	
Tag F.C.	Reader F.C.	Product Code	NULL
9	3	2	1

The 11 bytes of ADDITIONAL DATA contain additional information on the receiver:

ADDITIONAL DATA (11)	
Receiver S.N. (5 digits)	NULL
5	6

This interface can be activated through switch 2 on SW2.

⚠ NOTE: Magstripe2 interface can be activated only if Magstripe1 interface is activated

⚠ NOTE: The magstripe 2 port, if activated, trasmits only data from transponders activated by the LX2101s which are set as external, in which case the magstripe 1 port transmits only data from transponders activated by readers set as Internal (lsb to msb):

IN1: on connector J6, pin 1 (IN1) is a 3.3V NON-managed CMOS entrance

⚠ NOTE: we recommend that NO external electrical signal be interfaced

IN2: on connector J4, pin 5 (IN2) is a 3.3V NON-managed CMOS input

⚠ NOTE: we recommend that NO external electrical signal be interfaced

IN1: on connector J4, pin 6 (IN3) is a 3.3V NON-managed CMOS input

⚠ NOTE: we recommend that NO external electrical signal be interfaced

Antenna: on connector J3, connect the hot lead and ground of a 433 MHz antenna to the ANT and GND terminals

⚠ **NOTE:** keep the two ground connections for the RF circuit and the power supply circuit separated.

Operating mode

Set the operating mode with the dipswitch at the top of the board. The positions of the switches activate or deactivate the corresponding outputs as shown on the diagram. Pushing the switches up (ON) activates the respective outputs, while pushing them down (OFF) deactivates the outputs.

To make the settings effective the device must be reset (see button functions).

The data are transmitted in the following order (on the interfaces activated via the dipswitch)

1. TP - Tag Present (cannot be deactivated)
2. RS232 (cannot be deactivated)
3. RS485 – ethernet
4. Magstripe1
5. Magstripe2
6. Wiegand1
7. Wiegand2
8. Relay

Startup

When it is turned on, the device transmits a verification string with the version of firmware installed.

LEDs

LED1 (top right): when flashing, indicates reception of a correct piece of data at 433 MHz, always lighted, it indicates memory buffer full.

LED2 (top right): always lighted, it indicates correct power supply to the board

LED3 (center of card): indicates three different operating states

- one flash per second: correct operation
- two flashes per second: an invalid operating mode set on SW2
- steady: entry into stand-alone programme mode

Button functions

The button has different functions according to how it is pressed:

- Pressed for under 3 seconds: resets the receiver, as if it were turned off and back on
- Pressed for over 3 seconds: enters standard RS232 data mode at 9600 bps (9600,n,8,1) and waits for the password to be entered. This state is signalled by the led first flashing and then remaining steadily lit. One can thus enter programming mode from RS232 even without knowing the correct port setting. After reset, the RS232 port reverts to its original setting.

STAND ALONE MODE

In this mode, communication with the HOST is unidirectional and is always from device to host.

The programming interface is through a terminal menu in ASCII format, both on the RS232 serial interface and the RS485 serial interface. In the latter case, the RS485 connection, or alternatively, the ethernet connection, may be selected.

Select. 1	Select. 2	Select. 3	Select. 4	Select. 5	Select. 6	Meaning
ON/OFF - OFF	ON	OFF	OFF	ON/OFF - OFF	any	NOT PERMITTED
ON/OFF - OFF	ON	ON	OFF	ON/OFF - OFF	any	Wiegand1, Wiegand2
ON/OFF - OFF	ON	OFF	ON	ON/OFF - OFF	any	Magstripe2 , Magstripe1
ON/OFF - OFF	ON	ON	ON	ON/OFF - OFF	any	Networking
ON/OFF - OFF	OFF	OFF	OFF	ON/OFF - OFF	any	Ethernet or RS485
ON/OFF - OFF	OFF	ON	OFF	ON/OFF - OFF	any	Wiegand1
ON/OFF - OFF	OFF	OFF	ON	ON/OFF - OFF	any	Magstripe1
ON/OFF - OFF	OFF	ON	ON	ON/OFF - OFF	any	NOT PERMITTED
ON	any	any	any	ON	any	NOT PERMITTED

ASCII Stand Alone data format

Data are transmitted in the form of an ASCII string in which the fields, separated by the character “;” are the following:

tag F.C. (9 digits); receiver S.N. (5 digits); reader S.N. (3 digits); Reader Extension (1 digit, “I” or “E”); Product Code (2 digits); Time Present (1 digits); reader diagnostics (1 digit); tag diagnostics (1 digit)

These fields are always present, and there are optional fields which may be present in specific circumstances. The string ends with CR(0x0D) + LF(0x0A)

Time Present

Byte value	Meaning
0	No information
1	Followed by time information

tag F.C. (9 digits); receiver S.N. (5 digits); reader S.N. (3 digits); Reader Extension (1 digit, “I” or “E”); Product Code (2 digits); Time Present (1 digits); Time (17 digits); reader diagnostics (1 digit); tag diagnostics (1 digit)

The time has the following format: DD/MM/YY hh:mm:ss

Reader diagnostics

Byte value	Meaning
0	No information

1 Followed by diagnostics information

tag F.C. (9 digits); receiver S.N. (5 digits); reader S.N. (3 digits); Reader Extension (1 digit, "I" or "E"); Product Code (2 digits); Time Present (1 digit); reader diagnostics (1 digit); diagnostics information (5 digits); tag diagnostics (1 digit)

The diagnostics information has the following format: frequency (2 digits); power (2 digits)

TAG diagnostics

Byte value	Meaning
0	No information
1	Followed by diagnostics information

tag F.C. (9 digits); receiver S.N. (5 digits); reader S.N. (3 digits); Reader Extension (1 digit, "I" or "E"); Product Code (2 digits); Time Present (1 digit); reader diagnostics (1 digit); tag diagnostics (1 digit); diagnostics information (7 digits)

The diagnostics information has the following format: transmission cycles (3 digits); number of resets (3 digits)

ADDITIONAL INFORMATION

Following this there could be additional information, depending on the product code of the transponder.

TRACK mode

Counter: 5 digits

ECM mode

Direction: 1 digit

The coding is:

CODING	VALUE
0	Input
1	Output
2	Prob. Input
3	Prob. Output

Additional data

Are information that can be inserted in particular applications (es. Booster) and for this reason they do not have one fixed length. They come shown in format ascii like esadecimali values from the more significant byte (MSB) to the less significant byte (LSB)

Programming

To access programming mode, send the character “!”, and the receiver will respond to the command by requesting a 4-digit password (the default password is “0000”) confirmed by “SEND”.

Each menu of settings shows the parameter currently set

After entry of the correct password, the receiver transmits the more important informations and the command menu:

Factory code: 00000001
Serial number: 00001
RS232: 115200,8,N,1
RS485: 115200,8,N,1
Ethernet: 115200,8,N,1
TAG Filters: No
ACT Filters: No
A.P.B.: 00000
A.B.D.: No
Clock: 06/05/05 11:16:01

COMMAND MODE:

- (1)-TAG database reading
- (2)-TAG database writing
- (3)-TAG database adding
- (4)-ACT database reading
- (5)-ACT database writing
- (6)-ACT database adding
- (7)-Settings
- (8)-Clock reading
- (9)-Save and exit
- (0)-Exit without saving

Select the desired item by pressing the corresponding number.

TAG database reading

The receiver transmits the list of active tag codes followed by the number of records present.

TAG database writing

When this is selected, you are asked whether the previously memorized data should be erased.

Enter the transponder codes you want to activate by entering a code of up to 9 digits (max code 999999999) followed by “,”, after each entry, the receiver responds with the string “OK” to confirm that it has been memorized, or with “BAD” in the event of an error.

Continue to enter codes as desired, and to exit programming mode press the SEND button.

Up to 1280 transponder codes can be memorized.

TAG database adding

It is possible to add new transponder codes to those already memorized, following the same procedure as for database writing.

ACT database reading

The receiver transmits the list of active reader codes followed by the number of records present. The readers set as internal are indicated with an "I", and those set as external with an "E".

ACT database writing

When this is selected, you are asked whether the previously memorized data should be erased.

Enter the reader codes you want to activate by entering a code of up to 3 digits (max code 999) followed by "I" if it should be entered as internal, or "E" if it should be entered as External; after each entry, the receiver responds with the string "OK" to confirm that it has been memorized, or with "BAD" in the event of an error.

Continue to enter codes as desired, and to exit programming mode press the SEND button.

Up to 340 reader codes can be memorized.

ACT database adding

New reader codes may be added to the others already memorized, following the same procedure as for database writing.

SETTINGS

The following parameters may be changed by accessing the settings menu:

Settings:

- (1)-Change password
- (2)-Change Serial Number
- (3)-Set filters
- (4)-T rele ON
- (5)-T TP ON
- (6)-Set serial ports
- (7)-Set clock
- (8)-Set Anti Pass Back
- (9)-Automatic buffer deletion
- (0)-Exit settings

Change password

Enter a 4-digit numerical code (max 9999) to replace the default password.

Change serial number

Enter a numerical code (max 65535) to identify the receiver in the parameters transmitted via the interface ports.

Set filters

Allows the activation or disactivation of filters on transponder codes and reader codes based on the content of the programmed database, for the various communication interfaces:

SET FILTERS:

- (1)-Filter TAG RS232 (No)
- (2)-Filter ACT RS232 (No)
- (3)-Filter TAG RS485/Ethernet (No)
- (4)-Filter ACT RS485/Ethernet (No)
- (5)-Filter TAG MAG (No)
- (6)-Filter ACT MAG (No)
- (7)-Filter TAG WIE (No)
- (8)-Filter ACT WIE (No)
- (9)-Filter TAG RELAIS (No)
- (A)-Filter ACT RELAIS (No)
- (B)-Filter TAG TP (No)
- (C)-Filter ACT TP (No)
- (0)-Exit settings

When the desired item is selected, you are asked whether to activate the selected filter or not. Each interface is set independently of the others.

 NOTE: near every voiceis show actual value.

T Rele ON

Allows the relay contact time to be changed, in multiples of 125 ms, up to a maximum of 30 sec. Enter a number between 1 (125 ms) and 240 (30 sec).

T TP ON

Allows the duration of the Tag Present (TP) signal to be changed in multiples of 30 μ s, up to a maximum of approximately 2 sec. Enter a number between 1 (30 μ s) and 65535 (1.96605 sec).

Set serial ports

Allows the settings of the serial interfaces RS232 and RS485 to be modified.

- (1) Change RS232 baud rate: select the number corresponding to the desired setting from among the various options proposed
- (2) Change RS485 baud rate: select the number corresponding to the desired setting from among the various options proposed
- (3) Change Ethernet baud rate: select the number corresponding to the desired setting from among the various options proposed
- (4) Change RS232 protocol: enter the correct setting for each item proposed, the options are proposed between parentheses. Enter the per-character bit, the parity, and the stop bit.
- (5) Change RS485 protocol: enter the correct setting for each item proposed, the possible choices are proposed between parentheses.

- (6) Change Ethernet protocol: set the parameters for communication to the Ethernet module, entering the correct setting for each item proposed, the possible choices are proposed between parentheses.
- (0) Exit settings

Set clock

Allows you to change the setting of the internal clock; enter the hour, minutes, and seconds of the desired time, in that order.

The entry of each piece of information must be confirmed with "SEND"

 **NOTE:** the changes made become effective immediately.

Set Anti Pass Back (APB)

Allows you to change time, in second, within which they come combined the transmissions of every single transponder. This functionality is valid for last the 16 F.C. transponder receipts. Insert value "0" for disabled this function and the device becomes transparent to every received data. The breaking in of the data must be confirmed through "SEND".

Automatic buffer deletion

Allows you to set the automatic clearing of memory buffer, in networking mode, after the reception of "Get memory buffer" command (CMD 10)

NETWORKING

The receiver can function in SLAVE mode on a 485 or Ethernet network so as to create an addressable multipoint network. To access this mode, set the selectors of the SW2 dipswitch as shown in the table below; invalid combinations are signalled by led 3.

In this operating mode, the LX2002 receiver does NOT directly transmit the transponder codes it receives, but is capable of storing up to 70 codes in an EEPROM NON-CIRCULAR memory buffer with a variable number of data, and sending them all together when requested by the 485 or Ethernet network master using the appropriate command. The settings for filters on transponder and/or reader codes remain valid for the RS422/Ethernet and TP outputs, the only ones activated.

In this mode communication to the HOST is bidirectional, directed according to the factory code of the device, and occurs according to binary protocol; it is set by pushing up (ON) selectors 2-3-4 of the SW2 dipswitch.

The possible combinations of the other selector switches are:

Selector 1	Selector 5	Selector 6	Meaning
ON	OFF	any	Networking on Ethernet channel
OFF	ON	any	Networking on RS485 channel
ON	ON	any	NOT PERMITTED

Binary communication protocol

There is a set of commands for remote management of the device; all packets are addressed and include a header, 4 bytes which are always present (device factory code and command) followed by a variable payload on which the check sum is calculated.

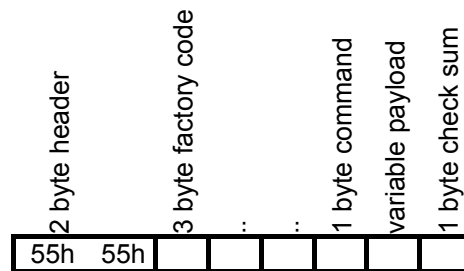

In the entire packet, the order of the bytes within the words is LSB-MSB.

The check sum (CS) is calculated as module 2 (XOR) of the PAYLOAD and of the Command byte

If the size of the payload is over 64 Byte, it is transmitted in multiple successive packets.

The command set is:

	Code (decimal)	Description	Parameter length (bytes)
Commands from host to device	1	Set operating parameters	13
	2	Get tag white list	0
	3	Set tag white list	Variable
	4	Get reader white list	0
	5	Set reader white list	Variable
	6	Delete tag white list	0
	7	Delete reader white list	0
	8	Get operating parameters	0
	9	Get device S.N.	0
	10	Get memory buffer	0
	11	Set relay ON	0
	12	Set relay OFF	0
	13	Get relay status	0
	14	Set time	4
	15	Get time	0
	16	Delete memory Buffer	0
Commands from device to host	26	Set Anti Pass Back	2
	27	Get Anti Pass Back	0
	17	Ack	0
	18	Nack	0
	19	TX operating parameters	13
	20	TX tag white list	Variable
	21	TX reader white list	Variable
	22	TX device S.N.	2
	23	TX memory buffer	Variable
	24	TX relay status	1
	25	TX time	4
	28	TX Anti Pass Back	2

The specific command parameters are the following:

CMD 01

Allows all configuration parameters for the receiver to be set, in the following payload format:

T RELAY ON	T TP ON	RECEIVER SETTING	FILTER SETTING	NEW S.N.	NEW PSW
1	2	3	2	2	2

The fields made up of two bytes are always in the order LSB-MSB.

- NEW S.N., must be between decimal values 0 and 65535
- NEW PSW, must be between decimal values 0 and 9999
- T RELAY ON, must be between decimal values 1 and 240
- T TP ON, must be between decimal values 1 and 65535
- RECEIVER SETTING bit definition:

BIT0 (lsb)	Always 0
BIT1	Always 0
BIT2	RS232 stop bit (0=1 stop bit, 1=2 stop bit)
BIT3	RS232 parity bit low
BIT4	RS232 parity bit high
BIT5	RS232 protocol bit (0=7bit, 1=8bit)
BIT6	RS232 Baudrate bit low
BIT7	RS232 Baudrate bit ...
BIT8	RS232 Baudrate bit high
BIT9	RS485 stop bit (0=1 stop bit, 1=2 stop bit)
BIT10	RS485 parity bit low
BIT11	RS485 parity bit high
BIT12	RS485 protocol bit (0=7bit, 1=8bit)
BIT13	RS485 Baudrate bit low
BIT14	RS485 Baudrate bit ...
BIT15	RS485 Baudrate bit high
BIT16	– Always 0
BIT24	
BIT25	Ethernet stop bit (0=1 stop bit, 1=2 stop bit)
BIT26	Ethernet parity bit low
BIT27	Ethernet parity bit high
BIT28	Ethernet protocol bit (0=7bit, 1=8bit)
BIT29	Ethernet Baudrate bit low
BIT30	Ethernet Baudrate bit ...
BIT31 (msb)	Ethernet Baudrate bit high

NOTE: the parity bit values for ports RS232 and RS485 and RS485/Ethernet are those shown in the table.

Parity	High bit	Low bit
None	0	0
Even	1	1
Odd	1	0

the bit values for the various baud rates of the RS232 port are those shown in the table.

<i>Baud rate (bps)</i>	<i>Bit 8</i>	<i>Bit 7</i>	<i>Bit 6</i>
9600	1	0	0
19200	0	1	1
38400	0	1	0
57600	0	0	1
115200	0	0	0

the bit values for the various baud rates of the RS485 port are those shown in the table.

<i>Baud rate (bps)</i>	<i>Bit 15</i>	<i>Bit 14</i>	<i>Bit 13</i>
9600	1	0	0
19200	0	1	1
38400	0	1	0
57600	0	0	1
115200	0	0	0

the bit values for the various baud rates of the Ethernet port are those shown in the table.

<i>Baud rate (bps)</i>	<i>Bit22</i>	<i>Bit 21</i>	<i>Bit 20</i>
9600	1	0	0
19200	0	1	1
38400	0	1	0
57600	0	0	1
115200	0	0	0

- FILTER SETTING bit definition:

BIT0 (lsb)	Always 0
BIT1	ABD: Activate/Disactivate automatic clearing of buffer
BIT2	Tag RS232 filter Activate/Disactivate search for tag code in the internal database
BIT3	Reader RS232 Filter: Activate/Disactivate search for tag code in the internal database
BIT4	Always 1
BIT5	RTC: Activate/Disactivate internal clock
BIT6	Reader-TP filter: Activate/Disactivate search for tag code in the internal database
BIT7	Tag- TP filter: Activate/Disactivate search for tag code in the internal database
BIT8	Reader-relay filter: Activate/Disactivate search for tag code in the internal database
BIT9	Tag-relay filter: Activate/Disactivate search for tag code in the internal database
BIT10	Reader-Wiegand filter: Activate/Disactivate search for tag code in the internal database
BIT11	Tag-Wiegand filter: Activate/Disactivate search for tag code in the internal database
BIT12	Reader-magstripe filter: Activate/Disactivate search for tag code in the internal database
BIT13	Tag-magstripe filter: Activate/Disactivate search for tag code in the internal database
BIT14	Reader-RS485/Ethernet filter: Activate/Disactivate search for tag

BIT15 (msb)	code in the internal database Tag-RS485/ethernet filter: Activate/Disactivate search for tag code in the internal database
----------------	--

If the command is properly received, the receiver transmits an acknowledge ACK (CMD 17), otherwise a NACK (CMD 18) is sent

CMD 02

The device is asked to transmit the transponder white list. The device may respond either by sending the white list (CMD 20) or with a NACK (CMD 18)

CMD 03

Add the new tag code into tag code database; the payload must be formatted in the following format:

<i>Length of packet</i>	<i>Factory Code TAG1</i>	<i>Factory Code TAG2</i>	<i>...</i>	<i>Factory Code TAGN</i>
2	4	4		4

The maximum length of the packet is 100 byte.

The device may respond either with an acknowledge (CMD 17) if the operation was successful, or with a NACK (CMD 18) in the event of an error.

CMD 04

The device is requested to transmit the reader white list. The device may respond either by sending the white list (CMD 21) or with a NACK (CMD 18)

CMD 05

Add the new reader code into reader code database; the payload must be formatted in the following format:

<i>Length of packet</i>	<i>S.N. READER1</i>	<i>S.N. Suffix READER1</i>	<i>...</i>	<i>S.N. READERN</i>	<i>S.N. Suffix READERN</i>
2	2	1		2	1

The S.N. suffix can be "I" if it is an Internal reader, or "E" if it is an External reader. The maximum length of the packet is 100 byte.

The device may respond either with an acknowledge (CMD 17) if the operation was successful, or with a NACK (CMD 18) in the event of an error.

CMD 06

The device is asked to cancel the tag white list.

The device may respond either with an acknowledge (CMD 17) if the operation was successful, or with a NACK (CMD 18) in the event of an error.

CMD 07

The device is asked to cancel the reader white list.

The device may respond either with an acknowledge (CMD 17) if the operation was successful, or with a NACK (CMD 18) in the event of an error.

CMD 08

The device is asked to transmit the operating parameters.

The device may respond either by transmitting the parameters (CMD 19) if the operation was successful, or with a NACK (CMD 18) in the event of an error.

CMD 09

The device is asked to transmit the current serial number set.

The device may respond either by transmitting the serial number (CMD 22) if the operation was successful, or with a NACK (CMD 18) in the event of an error.

CMD 10

The device is asked to transmit the memory buffer currently in place on the side of the device.

The device may respond either by transmitting the buffer (CMD 23), or with a NACK (CMD 18) in the event of an error.

⚠ NOTE: when memory buffer is full, led1 is always lighted .

CMD 11

Upon receiving this command, the device closes the N.O. relay contact, regardless of the current state of the relay.

In response, the device may either send an acknowledge (CMD 17) if the operation was successful, or with a NACK (CMD 18) in the event of an error.

CMD 12

Upon receiving this command, the device open the N.O. relay contact, regardless of the current state of the relay.

In response, the device may either send an acknowledge (CMD 17) if the operation was successful, or with a NACK (CMD 18) in the event of an error.

CMD 13

The device is asked to transmit the status of the N.O. relay contact, and in response it may either transmit the relay status (CMD 24) or a NACK (CMD 18) in the event of an error.

CMD 14

This command sets the device's internal clock, and the payload must have the following format::

<i>Year</i>	<i>Month/Day /Hour</i>	<i>Minutes</i>
1	2	1

in which:

- Year: number between 0 (the year 2000) and 99 (2099)
- Month/Day/Hour bit definition:

BIT0 (lsb)	day lsb
BIT1	day
BIT2	day
BIT3	day
BIT4	day
BIT5	day msb
BIT6	month lsb
BIT7	month
BIT8	month
BIT9	month msb
BIT10	hour lsb
BIT11	hour
BIT12	hour
BIT13	hour
BIT14	hour
BIT15	hour msb

- Minutes: number between 0 and 59

in response, the device may either transmit an ACK (CMD 17), or a NACK (CMD 18) in the event of an error.

CMD 15

The device is asked to transmit the time currently set, and in response it may either transmit the current time setting (CMD 25) or a NACK (CMD 18) in the event of an error.

CMD 16

The device is asked to clear all memory buffer. In response it may either transmit an ACK (CMD 17) or a NACK (CMD 18) in the event of an error.

CMD 17

The device sends an ACK each time a command is correctly carried out

CMD 18

The device sends a NACK each time a command is NOT correctly carried out

CMD 19

The device transmits all configuration parameters, and the payload has the following format

T RELAY ON	T TP ON	RECEIVER SETTING	FILTER SETTING	NEW S.N.	NEW PSW
1	2	4	2	2	2

 **NOTE:** for details on the meaning of each byte, refer to the CMD 01 command

CMD 20

Upon request, the device transmits the entire database of tag codes, and the payload must be formatted as follows:

<i>Device S.N.</i>	<i>Total data length</i>	<i>Packet length</i>	<i>TAG1 Factory Code</i>	<i>TAG2 Factory Code</i>	<i>...</i>	<i>TAGN Factory Code</i>
2	4	2	4	4		4

The maximum length of the packet is 250 byte.

⚠ NOTE: if tag code database is empty, the device transmits only Device S.N.

CMD 21

Upon request, the device transmits the entire database of reader codes, and the payload must be formatted as follows:

<i>Device S.N.</i>	<i>Total data length</i>	<i>Packet length</i>	<i>S.N. READER1</i>	<i>S.N. suffix READER1</i>	<i>...</i>	<i>S.N. READERN</i>	<i>S.N. suffix READERN</i>
2	4	2	2	1		2	1

The S.N. suffix may be "I" if the reader is Internal, or "E" if the reader is External

The maximum length of the packet is 250 byte.

⚠ NOTE: if reader code database is empty, the device transmits only Device S.N.

CMD 22

Upon request, the device transmits the serial number currently set, and the payload must be formatted as follows:

S.N.
2

CMD 23

Upon request, the device transmits the entire memory buffer currently recorded. The payload must be formatted as follows:

<i>Device S.N.</i>	<i>Total data length</i>	<i>Packet length</i>	<i>TAG1 Time status</i>	<i>TAG1 frame</i>	<i>TAG1 Time</i>	<i>...</i>	<i>TAGN Time status</i>	<i>TAGN frame</i>	<i>TAGN Time</i>
2	4	2	1	variable	4	...	1	variable	4

For the formatting of the TAG frame, refer to the documentation on the LX1004 Linx transponder.

For the formatting of the TAG time, refer to the description of the CMD 25 command.

The maximum length of the packet is 250 byte.

⚠ NOTE: if memory buffer is empty, the device transmits only Device S.N.

Time status	Meaning
0	The TAG frame does NOT also include time of reception (TIME)
1	The TAG frame also includes time of reception (TIME)

CMD 24

Upon request, the device transmits the current status of the N.O. relay contact, and the payload must be formatted as follows:

Relay status
1

in which:

CODING	N.O. Contact
0	Open
1	Closed

CMD 25

Upon request, the device transmits the current setting of the internal clock, and the payload must be formatted as follows:

Year	Month/Day/Hour	Minutes	Seconds	1/100
1	2	1	1	1

in which:

Year: number between 0 (the year 2000) and 99 (2099)

Month/Day/Hour bit definition:

BIT0 (lsb)	day lsb
BIT1	day
BIT2	day
BIT3	day
BIT4	day
BIT5	day msb
BIT6	month
	lsb
BIT7	month
BIT8	month
BIT9	month
	msb
BIT10	hour lsb
BIT11	hour
BIT12	hour
BIT13	hour
BIT14	hour
BIT15	hour
	msb

- Minutes: number between 0 and 59
- Seconds: number between 0 and 59

- 1/100: number between 0 and 100

CMD 26

This command sets the device's Anti Pass Back value on second format, and the payload must have the following format::

Anti Pass Back (s)
2

If the value is set to 0 this function is disabled.

CMD 27

The device is asked to transmit the Anti Pass Back currently set, and in response it may either transmit the current Anti Pass Back setting (CMD 28) or a NACK (CMD 18) in the event of an error.

CMD 28

Upon request, the device transmits the current value of the anti pass back, and the payload must be formatted as follows:

Anti Pass Back
2

If the value is 0 this function is disabled.

6. ELECTRICAL AND MECHANICAL SPECIFICATIONS

6.1. Activator UKOPLX2101FHU

Mechanical characteristics

<i>Parameter</i>			
External dimensions (L x H x W)	158 mm	95 mm	45 mm
Protection rating	IP 56		
Colour	RAL 9002 Ivory		

External interface

<i>Parameter</i>	
Power supply	Threaded bipolar terminal
RS422	2 threaded bipolar terminals
Power supply	12/24 V AC-DC

Electrical characteristics

<i>Parameter</i>	<i>Min.</i>	<i>Typ.</i>	<i>Max.</i>
Input supply voltage (V_{ac} / V_{dc})– switching input	10 V	12/24 V	26 V
Power consumption		1.5 W	3 W

Environmental specifications

<i>Parameter</i>	<i>Min.</i>	<i>Typ.</i>	<i>Max.</i>
Temperature range for operation	-10 °C		+60 °C
Temperature range for storage	-55 °C		+125 °C
Humidity	--	--	--

Radio unit specifications

Band	2419,5 to 2464,5MHz	
Numbers of channels	15	
Channels spacing	3MHz	
Channels bandwidth	3MHz	
Dwell time for channel	270ms	
Data transfer type	Unidirectional	
Modulation	OOK/AM	
Coding	Manchester	
Bitrate	9600 bps	
Output power	Max.	+17 dBm (average)
Min. (PA off)	2 dBm	
Output impedance	50 Ω	

Antenna specifications: AME ANT 2.44

Type	Planar suspended patch
Total gain	+6 dBi
Polarization	Circular
Lobe aperture	Approximately 30°
Shape of lobe aperture	Circular cone

AME PLX 2101FHU radio transmission comply with FCC 15.247

6.2. Trasponder UKOPLX1004STU & UKOPLX1004QDU

Mechanical characteristics

<i>Parameter</i>			
External dimensions (L x H x W)	95 mm	56 mm	9 mm
Protection rating	IP20		
Colour	White, customized on request		

UKOPLX1004STU

<i>Parametro</i>			
Dimensioni esterne (L x H x P)	95 mm	56 mm	9 mm
Grado di Protezione	IP20		
Colore	White, customized on request		

UKOPLX1004QDU

<i>Parameter</i>			
External dimensions (L x H x W)	55 mm	55 mm	12 mm
Protection rating	IP20		
Colour	White, grey, black, customized on request		

Electrical characteristics

<i>Parameter</i>	<i>Min.</i>	<i>Typ.</i>	<i>Max.</i>
Duty cycles			>100,000
Input supply voltage(Vcc) 3 V (mod. Lithium battery.) 2032)	2.7V	3 V	3.3 V
Power consumption			
Active in TX RF			25 mA
Active in RX MW	4 mA		
Standby		1.5 μ A	
Total			25 mA

Environmental specifications

<i>Parameter</i>	<i>Min.</i>	<i>Typ.</i>	<i>Max.</i>
Temperature range for operation	-10 °C		+60 °C
Temperature range for storage	-55 °C		+125 °C
Humidity	--	--	--

Radio Frequency Specifications

433 MHz. transmitter

Band	European ISM 433
Operating frequency	433.92 MHz
Data transfer type	Unidirectional
Modulation	OOK / AM
Coding	Manchester
Bitrate	4800 bps
Outdoor range min	30 m
Output power max	-14 dBm e.i.r.p.

Complies with FCC 15.231 standards

2.45 GHz receiver

Band	2400 – 2483 MHz
Operating frequency	-
Data transfer type	Unidirectional
Modulation	OOK / AM
Coding	Manchester
Outdoor range	8 m
Rx sensitivity	-35 dBm

6.3. Receiver UKOPLX2002

Mechanical characteristics

<i>Parameter</i>			
External dimensions (L x H x D)	158 mm	95 mm	45 mm
Protection rating	IP 56		
Colour	RAL 9002 Ivory		

Electrical characteristics

<i>Parameter</i>	<i>Min.</i>	<i>Typ.</i>	<i>Max.</i>
Input supply voltage (V_{AD}/V_{CC})	10 V	12/24 V	26 V
Power consumption		1 W	3 W
Input port voltage +5V regulated DC (VCC)	4.8 V	5 V	5.2 V

Specific external interfaces

<i>Interface</i>	<i>Characteristics</i>
RS232	Standard
RS485	Standard
Wiegand:	Open Drain max 12 V
Magstripe	Open Drain max 12 V
T.P.	Open Drain max 12 V
Relay	Max 1A 30 V Vdc – Max 1A 125 V Vac
IN1	Cmos input, voltage levels min.3.267V - Typ.3.3 V - max.V3.333 V
IN12	Cmos input, voltage levels min.3.267V - Typ.3.3 V - max.V3.333 V
IN13	Cmos input, voltage levels min.3.267V - Typ.3.3 V - max.V3.333 V

Radio Frequency Specifications

<i>Band</i>	European ISM 433
<i>Operation frequency</i>	433.92 MHz
<i>Data transfer type</i>	Unidirectional
<i>Modulation</i>	OOK / AM
<i>Input Power Min. (PA off)</i>	-56 dBm
<i>Output impedance</i>	50 Ω

Environmental specifications

<i>Parameter</i>	<i>Min.</i>	<i>Typ.</i>	<i>Max.</i>
Temperature range for operation	-10 °C		+60 °C
Temperature range for storage	-55 °C		+125 °C
Humidity	--	--	--

7. LAN PLX2002 CONFIGURATION (OPTIONAL FUNCTION)

Optional network support.

See the manual supplied with the apparatus equipped with the Ethernet interface module.

8. STARTING THE APPARATUS

Once the installation and configuration of the LNX apparatuses is completed, the system starts operating immediately, as soon as it is powered. Using the supplied TAGs, its operation can be verified.

9. TEST

After verifying the correct installation, as indicated above, the correct operation of the system has to be verified as well.

This means that:

- ✓ in installation mode **1**, when the vehicle approaches the barrier within the reaction time of the opening system, the barrier has to start opening.
- ✓ in installation mode **2**, when the vehicle approaches the barrier it has to find it already opened (according to the assumptions made).

With regard to personal use, the system operates properly if, when the person approaches the barrier, correctly “wearing” the transponder, (s)he is detected by the system.

10. PRECAUTIONS

The degree of protection does not allow to withstand jets of water under pressure sprayed onto the apparatus.

11. MAINTENANCE

TAG BATTERY REPLACEMENT PROCEDURE After replacing the batteries, press the RESET button to restart the transponder.

Only qualified personnel are authorised to service the illuminator and receiver apparatuses.