

<b>TEST REPORT</b>	
Secondo i seguenti Standard / <i>According to following Standards</i>	
<b>Test specification</b>	FCC Part 15: Subpart C Section 15.247: 2015 Test plan: TP-15LA00198/01_151008_REGATE-10-11-16
Maximum Conducted Output Power, Section 15.247 (b) (3) for WLAN	<b>Conforme/Compliant</b>
Maximum Power Spectral Density, Section FCC 15.247(e) for WLAN	<b>Conforme/Compliant</b>
6 dB Bandwidth, Section 15.247 (a) (2) for WLAN	<b>Conforme/Compliant</b>
Band-edge Compliance, Section 15.247(d) for WLAN	<b>Conforme/Compliant</b>
Conducted Spurious Emissions, Section 15.247(d) for WLAN	<b>Conforme/Compliant</b>
AC Power Line Conducted Emissions, Section 15.207 (WLAN, BT and GSM active)	<b>Conforme/Compliant</b>
Spurious Radiated Emissions and Restricted Bands of Operation, Section 15.209 and 15.205 (WLAN, BT and GSM active)	<b>Conforme/Compliant</b>
<b>Richiedente / Applicant's name</b> ..... :	Eurotech Spa
Indirizzo / Address .....	Via F.lli Solari 3/A – 33020 Amaro (UD) - Italy
<b>Produttore / Manufacturer</b> ..... :	Eurotech Spa
Indirizzo / Address .....	Via F.lli Solari 3/A – 33020 Amaro (UD) - Italy
<b>Dispositivo sottoposto ai test/ Device Under Test</b> ..... :	ReliaGATE 10-11-16
<b>Data di emissione/ Date of issue</b>	23 <sup>rd</sup> February 2016
<b>Validità / Validity</b>	Vedi sezione 1.1 / <i>See section 1.1</i>
<b>Test report redatto da/ Author of Test report</b> .....	Loris Fruch
<b>Tecnico/i di prova Engineer/s</b> .....	Loris Fruch Responsabile di prova/ <i>Test manager</i> : Giovanni Solari
<b>Approvato da (+ firma) Approved by (+ signature)</b> .....	Silvano Chialina .....
	Responsabile del laboratorio/ <i>Head of the Laboratory</i>
<b>Laboratorio / Testing Laboratory</b> . :	EmilabSrl
Indirizzo / Address .....	Via F.lli Solari 5/A – 33020 Amaro (UD) - Italy

## Index

<b>1.</b>	<b>INFORMAZIONI GENERALI / GENERAL INFORMATION</b>	<b>5</b>
1.0	Laboratorio / Testing Laboratory	5
1.1	Campionamento e Documentazione / <i>Sampling and Documentation</i>	5
1.2	Specifiche del test / <i>Test specifications</i>	5
1.3	Svolgimento dei test e condizioni generali / <i>Test scheduling and general condition</i>	6
1.4	Espressione dei risultati finali / <i>Test case of final verdicts</i>	6
1.5	Incertezza / <i>Uncertainty</i>	7
1.6	Termini, Definizioni e Acronimi/ <i>Terms, definitions and abbreviations</i>	7
<b>2.0</b>	<b>APPARECCHIATURA SOTTOPOSTA A TEST/ DEVICE UNDER TEST</b>	<b>8</b>
2.1	CHANNEL LIST	11
2.3	SELECTED MODULATION MODES AND CHANNEL DETAILS	12
<b>3.0</b>	<b>MAXIMUM CONDUCTED OUTPUT POWER-CONDIZIONI DI PROVA / TEST CONDITIONS</b>	<b>13</b>
3.1	Apparecchiature utilizzate / <i>Test Equipment Used</i> – Maximum Conducted Output Power	13
3.2	Fotografie del setup / <i>Photo of the test setup</i> –Maximum Conducted Output Power	14
3.3	Risultati / <i>Results</i> - Maximum Conducted Output Power	14
3.3.1	Tabelle e grafici dei risultati / <i>Tables and graphical representation of data</i> – <i>Maximum Conducted Output Power</i>	14
<b>4.0</b>	<b>MAXIMUM POWER SPECTRAL DENSITY-CONDIZIONI DI PROVA / TEST CONDITIONS</b>	<b>22</b>
4.1	Apparecchiature utilizzate / <i>Test Equipment Used</i> – Maximum Peak Conducted Output Power	22
4.2	Fotografie del setup / <i>Photo of the test setup</i> – Maximum Power Spectral Density	23
4.3	Risultati / <i>Results</i> - Maximum Power Spectral Density	23
4.3.1	Tabelle e grafici dei risultati / <i>Tables and graphical representation of data</i> – <i>Maximum Power Spectral Density</i>	23

<b>5.0</b>	<b>BANDWIDTH - CONDIZIONI DI PROVA / TEST CONDITIONS</b>	<b>31</b>
5.1	Apparecchiature utilizzate / <i>Test Equipment Used</i> – Maximum Peak Conducted Output Power	31
5.2	Fotografie del setup / <i>Photo of the test setup</i> –Bandwidth	32
5.3	Risultati / <i>Results</i> - Bandwidth	32
5.3.1	Tabelle e grafici dei risultati / <i>Tables and graphical representation data</i> –Bandwidth	32
<b>6.0</b>	<b>BAND-EDGE COMPLIANCE - CONDIZIONI DI PROVA / TEST CONDITIONS</b>	<b>40</b>
6.1	Apparecchiature utilizzate / <i>Test Equipment Used</i> – Maximum Peak Conducted Output Power	40
6.2	Fotografie del setup / <i>Photo of the test setup</i> –Band-edge Compliance	41
6.3	Risultati / <i>Results</i> - Band-edge Compliance	41
6.3.1	Tabelle e grafici dei risultati / <i>Tables and graphical representation of data</i> – <i>Band-edge Compliance</i>	42
<b>7.0</b>	<b>CONDUCTED SPURIOUS EMISSIONS -CONDIZIONI DI PROVA / TEST CONDITIONS</b>	<b>46</b>
7.1	Apparecchiature utilizzate / <i>Test Equipment Used</i> – Maximum Peak Conducted Output Power	46
7.2	Fotografie del setup / <i>Photo of the test setup</i> –Conducted Spurious Emissions	47
7.3	Risultati / <i>Results</i> - Conducted Spurious Emissions	47
7.3.1	Grafici dei risultati / <i>Graphical representation data</i> – Conducted Spurious Emissions	48
<b>8.0</b>	<b>CONDUCTED EMISSION - CONDIZIONI DI PROVA / TEST CONDITIONS</b>	<b>50</b>
8.1	Apparecchiature utilizzate / <i>Test Equipment Used</i> – Conducted emission	50
8.2	Fotografie del setup / <i>Photo of the test setup</i> – Conducted emission	51
8.3	Risultati / <i>Results</i> - Conducted emission	51
8.3.1	Grafici dei risultati / <i>Graphical representation data</i> – Conducted emission	52
<b>9.0</b>	<b>SPURIOUS RADIATED EMISSIONS AND RESTRICTED BANDS OF OPERATION - CONDIZIONI DI PROVA / TEST CONDITIONS</b>	<b>56</b>
9.1	Apparecchiature utilizzate / <i>Test Equipment Used</i> – Spurious Radiated Emissions and Restricted Bands of Operation	57

<b>9.2</b>	<b>Fotografie del setup / <i>Photo of the test setup</i> –Spurious Radiated Emissions and Restricted Bands of Operation</b>	<b>58</b>
<b>9.3</b>	<b>Risultati / <i>Results</i> - Spurious Radiated Emissions and Restricted Bands of Operation</b>	<b>59</b>
<b>9.3.1</b>	<b>Tablelle e grafici dei risultati / <i>Tables and graphical representation data</i> – Spurious Radiated Emissions and Restricted Bands of Operation</b>	<b>59</b>
<b>9.3.1.1</b>	<b>Restricted Bands of Operation</b>	<b>60</b>
	<b>Allegato 2 / Annex 2: Incertezza / Uncertainty</b>	<b>89</b>

## 1. Informazioni Generali / *General Information*

### 1.0 Laboratorio / *Testing Laboratory*

<b>Luogo di Prova e partecipanti / <i>Testing location and participants:</i></b>	
<b>Testing Laboratory:</b>	
Testing location/ address.....:	EmilabSrl Via F.lli Solari 5/A – 33020 Amaro (UD) – Italy Tel +39 0433 468625 Fax +39 0433 494739 Email: <a href="mailto:info@emilab.it">info@emilab.it</a>
Partecipanti / <i>Participants:</i>	Loris Fruch, Pierluigi Pollano (Eurotech Spa), Pierluigi Driusso (Eurotech Spa)

### 1.1 Campionamento e Documentazione / *Sampling and Documentation*

I campioni sono stati consegnati dal Cliente. I risultati dei test contenuti in questo documento si riferiscono esclusivamente al modello e numero di serie provato. E' responsabilità del costruttore assicurare che la produzione dei modelli in serie rispetti i requisiti del presente documento. Questo documento non può essere riprodotto in parte senza il consenso scritto del responsabile del laboratorio EMILAB.

EMILAB non si assume nessuna responsabilità per danni derivanti da interpretazioni che esulano dal contesto e dall'applicazione del presente documento.

*The samples was delivered by customer. The results contained in this report reflect the results for this particular model and serial number. It is the responsibility of the manufacturer to ensure that all production models meet the intent of the requirements detailed within this report. This report shall not be reproduced, except in full, without the written approval of the Issuing testing Emilab laboratory.*

*EMILAB takes no responsibility for and will not assume liability for damages resulting from the reader's interpretation of the reproduced material due to its placement and context.*

### 1.2 Specifiche del test / *Test specifications*

<b>Test performed according to:</b>	
Test plan	TP-15LA00198/01_151008_REGATE-10-11-16 Date:08/10/2015 Author: Stefano Zanolin - Eurotech S.p.A.
Test specification	FCC CFR 47 - Part 2 and Part 15:2015 (Subpart B e C)
Basic Specifications	ANSI C63.10: 2009-09 American National Standard for Testing Unlicensed Wireless Devices. <i>Frequency Range of the accreditation scope of the Lab. (ACCREDIA): up to 18GHz.</i>

### 1.3 Svolgimento dei test e condizioni generali / Test scheduling and general condition

<b>Svolgimento dei test/ Scheduling</b> .....	
Data ricezione EUT	
<i>Date of receipt of EUT</i> .....	29/10/2015
Data esecuzione test	
<i>Date (s) of performance of tests</i> .....	04/11/2015 – 23/02/2016
<b>Condizioni ambientali</b> <i>/ Environment Conditions</i>	Se non diversamente specificato / <i>If not otherwise specified:</i> Temperature: 18-28°C Humidity: 20-90% Pressure: 87-108.56 kPa
<b>Intervallo delle tarature/</b> <i>Calibration Interval</i>	Minimum 1 year

### 1.4 Espressione dei risultati finali / Test case of final verdicts

**I GIUDIZI NON SONO SOGGETTI AD ACCREDITAMENTO**

**/ VERDICTS ARE NOT SUBJECT TO ACCREDITATION**

- test case does not apply to the test object..... : N/A
- test object does meet the requirement..... : Compliant or PASS
- test object does not meet the requirement ..... : Not Compliant or FAIL

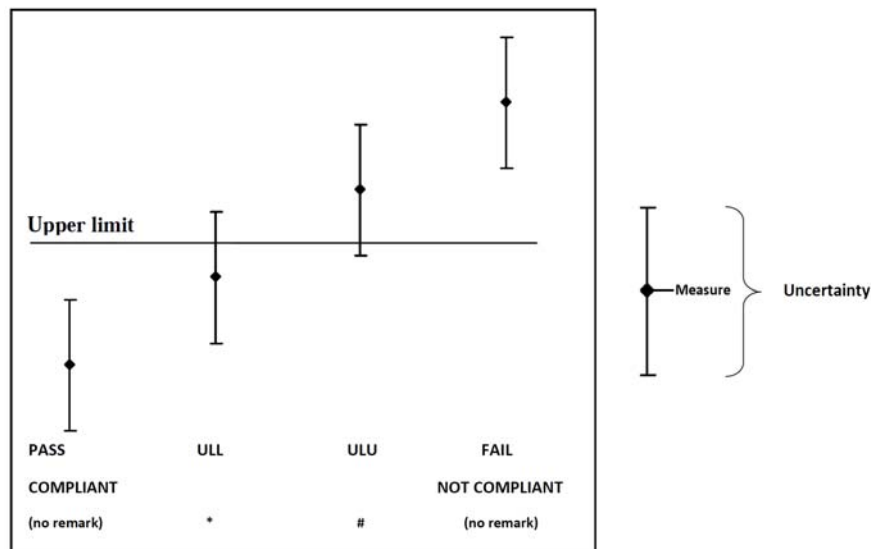

Results marked with a NOT COMPLIANT or FAIL do not meet specifications with a probability of >95%, the total uncertainty interval is located outside the specified limits.

Measurement results are marked with an "\*" or "#" (uncertain) if the uncertainty interval is partly within and partly out of the specified limits. A clear compliance statement is not possible.

All results not marked are located within the specified limits even when extended by the uncertainty interval

## 1.5 Incertezza / Uncertainty

L'incertezza estesa riportata è espressa come l'incertezza tipo moltiplicata per il fattore di copertura  $k = 2$ , che per una distribuzione normale corrisponde ad una probabilità di copertura di circa il 95 %.

*The reported expanded uncertainty of measurements is stated as the standard uncertainty of measurement, multiplied by the coverage factor  $k=2$ , which for a normal distribution corresponding to a coverage probability of approximately 95%.*

## 1.6 Termini, Definizioni e Acronimi/ Terms, definitions and abbreviations

AC	Alternating Current
ACK	Acknowledgement
AFH	Adaptive Frequency Hopping
AM	Amplitude modulation
AVE det	Average Detector
BIT	Burst Interval Time
CAC	Channel Availability Check
BW	BandWidth
CCA	Clear Channel Assessment
CW	Continuous Wave
DAA	Detect And Avoid
DC	Duty Cycle DFS
DFS	Dynamic Frequency Selection
DSSS	Direct Sequence Spread Spectrum
DUT	Device Under Test
e.i.r.p.	equivalent isotropically radiated power
e.r.p.	effective radiated power
EMC	Electro Magnetic Compatibility
EUT	Equipment Under test
FAR	Fully Anechoic Room
FHSS	Frequency Hopping Spread Spectrum
HT20 High	Throughput in a 20 MHz channel
HT40 High	Throughput in a 40 MHz channel
ISM	Industrial, Scientific and Medical
LBT	Listen Before Talk
LPDA	Logarithmic Periodic Dipole Antenna
MCS	Modulation Coding Scheme
MIMO	Multiple Input, Multiple Output
MU	Medium Utilisation
MS/s	Mega-Samples per second
NACK	Not Acknowledged
OATS	Open Air Test Site
OFDM	Orthogonal Frequency Division Multiplexing
OM	Operating Modes
OOB	Out Of Band
PK det	Peak Detector
PM	pulse modulation
Ppm	parts per million
PPS	Pulses Per Second
PRF	Pulse Repetition Frequency
RBW	Resolution BandWidth
RE	Radiated Emission
RLAN	Radio Local Area Network
RMS	Root Mean Square
R&TTE	Radio and Telecommunications Terminal Equipment
RF	Radio Frequency
Rx	Receiver
SAC	Semi Anechoic Chamber
TEM	transverse electromagnetic
TL	Threshold Level
TPC	Transmit Power Control
Tx	Transmitter
VBW	Video BandWidth
VSWR	voltage standing wave ratio
WLAN	Wireless Local Area Network
BT	Bluetooth
BLE	Bluetooth Low Energy

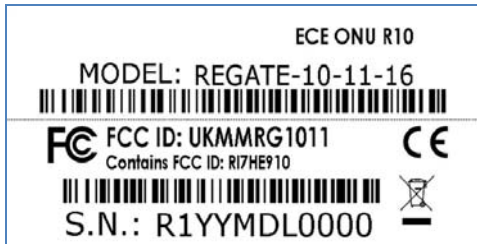

## 2.0 Apparecchiatura sottoposta a test/ *Device Under Test*

Descrizione/ <i>Description</i> .....:	The ReliaGATE 10-11-16 is a compact and lightweight IoT gateway based on the powerful TI AM 335X microprocessor. It integrates 4 GB of eMMC storage that can be expanded using the MicroSD card slot available behind the Service panel.
Marchio commercial / <i>Trade Mark</i> .....:	
Produttore / <i>Manufacturer</i> .....:	Eurotech Spa
Modello / <i>Model/Type reference</i> .....:	REGATE-10-11-16
Voltage/Current.....:	9±36Vdc (nominal 24Vdc) / 0.1A
Frequency.....:	/
Power.....:	2.5W
Numero EUT / <i>EUT Number</i> .....:	15LA00198/01
Serial Number.....:	R1YYMDL0000
Numero di campioni testati / <i>Number of samples tested</i> .....:	1
Hardware stage/level.....:	1.0
Software stage/level.....:	1.0
Modification stage.....:	/
Operating Mode.....:	<p>Mode 1 (Radio tests conducted measurements): the EUT is connected only to power supply line and WLAN/Bluetooth antenna output (50ohm, SMA) is connected to the Spectrum Analyser. WLAN link was set using the Access Point Intellinet 524704.</p> <p>Mode 2 (Radiated measurements): the EUT executes the test software“./testALL.sh -m EU” through one SSH connection from control PC (placed outside the SAC) to the EUT. WLAN link was set using the Access Point Intellinet 524704. Bluetooth is activated as well by the test routine in hopping mode. GSM900 or GSM1800 link was active as well.</p> <p>Mode 3 (Radiated measurements): WLAN link was set on single channel using the Access Point Intellinet 524704.</p> <p>Mode 4 (Radiated measurements): Bluetooth is set on single channel using the test routine “./fccbluetooth.sh” provided by the applicant.</p> <p>During the tests the DUT WLAN/BT transmitters were set at their maximum Tx-power, as per control software setting.</p>



Wiring harness .....	Power supply Harness (2mt length); Ethernet line (2mt length), Digital I/O, CAN and RS232 lines (2mt length); Multi band antenna (GSM, WLAN and Bluetooth) 3 x coaxial cables (4mt length); All signal cables are shielded.
Monitoring .....	/

**Info:**

Other Emilab reports related to the same product: (BT:16-02234, BLE: 16-02235, RF Exposure:16-02236)

The test results collected in this report are confirmed in all the voltage range of EUT power supply (9÷36V dc).

**DUT Hardware features**

Processor: TI AM335X, 800 MHz, 1 core, RAM: 512MB DDR3, Embedded storage: 4GB eMMC, Additional storage Micro SD card slot available behind the Service panel

**Wired Interfaces:**

- Ethernet: 1 x Fast Ethernet port (external)
- CAN: 2 x CAN ports (Version 2 Parts A and B)
- USB: 2 x USB 2.0 host port, 1x USB 2.0 client port
- Serial: 1x TTL for OS console (available behind the Service panel) 2x RS232/485 configurable
- Digital I/O: 2 x insulated digital inputs and 2x insulated digital outputs

**Wireless Interfaces:**

- Cellular: 3G global, Telit HE910 DG
- Wi-Fi: 802.11 b/g/n
- Bluetooth: 4.0
- GPS: 28-channel GPS integrated in Cellular
- RF output connectors: 1 x SMA for Cellular, 1x SMA for GPS, 1x SMA for Wi-Fi/Bluetooth

**ESA modifications at manufacturer's care:**

- Before of the tests a ferrite model "Fair-rite 0431164281" was placed with one turn on the EUT power supply cable near to its case;

**Auxiliary equipment for tests supplied by the applicant:**

- Personal Computer Acer, model Travelmate C300;
- Access Point Intellinet, model 524704;
- Multi band antenna Mobile Mark, model SMW-UMB-3C3C3C with integral RF coaxial cables L=4mt;
- AC/DC adapter W&T Type FW7520/24;

GSM notation Telit HE910 FCC ID: RI7HE910

**GSM Radio Base Station simulator settings:**

During "Spurious Radiated Emissions and Restricted Bands of Operation, Section 15.209 and 15.205" tests, the GSM link was activated (channel 740 or 62) using the RBS simulator R&S CMU 200 with the following settings:

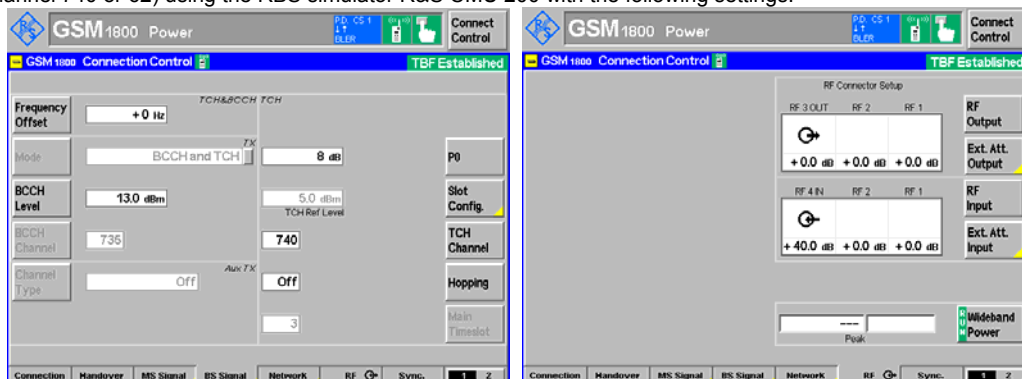

LAB N° 0986

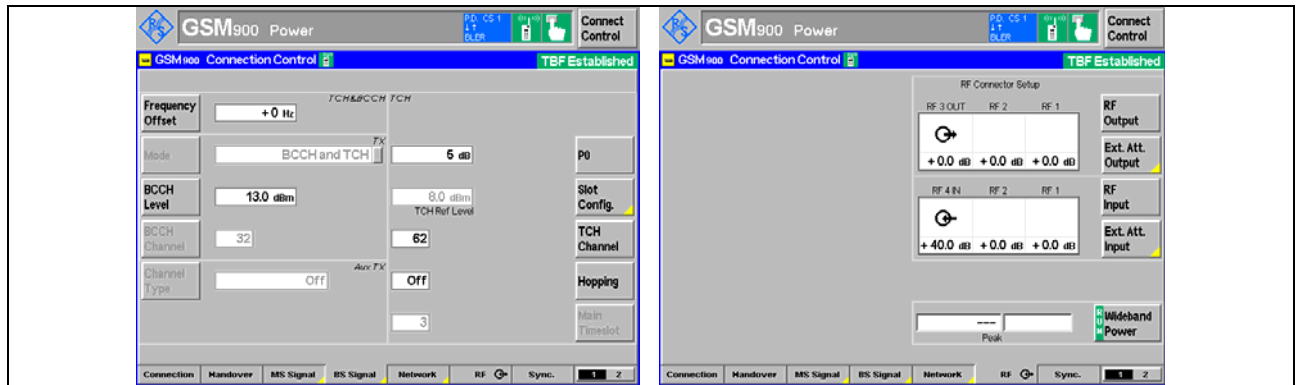

## 2.1 Channel List

### Wi-Fi

Frequency band [MHz] 802.11 b / g / n HT20 – HT40	
Channel	Frequency [MHz]
1	2412
2	2417
3	2422
4	2427
5	2432
6	2437
7	2442
8	2447
9	2452
10	2457
11	2462

### Bluetooth

Frequency band [MHz]: 2400 – 2483.5							
Channel	Frequency [MHz]	Channel	Frequency [MHz]	Channel	Frequency [MHz]	Channel	Frequency [MHz]
0	2402	20	2422	40	2442	60	2462
1	2403	21	2423	41	2443	61	2463
2	2404	22	2424	42	2444	62	2464
3	2405	23	2425	43	2445	63	2465
4	2406	24	2426	44	2446	64	2466
5	2407	25	2427	45	2447	65	2467
6	2408	26	2428	46	2448	66	2468
7	2409	27	2429	47	2449	67	2469
8	2410	28	2430	48	2450	68	2470
9	2411	29	2431	49	2451	69	2471
10	2412	30	2432	50	2452	70	2472
11	2413	31	2433	51	2453	71	2473
12	2414	32	2434	52	2454	72	2474
13	2415	33	2435	53	2455	73	2475
14	2416	34	2436	54	2456	74	2476
15	2417	35	2437	55	2457	75	2477
16	2418	36	2438	56	2458	76	2478
17	2419	37	2439	57	2459	77	2479
18	2420	38	2440	58	2460	78	2480
19	2421	39	2441	59	2461	-	-

## 2.3 Selected Modulation Modes and Channel Details

### Wi-Fi (WLAN)

Test Item	Mode	Test Frequency [MHz]	Data Rate
Spurious Radiated Emissions	11b	2437	1Mbps
Restricted Bands of Operation	11b	2462	11Mbps
Maximum Conducted Output Power Power Spectral Density 6dB Spectrum Bandwidth	11b 11g 11n (HT20)	2412 / 2437 / 2462 2412 / 2437 / 2462 2412 / 2437 / 2462	1-11Mbps 6-24-54Mbps 6.5-39-65Mbps
	11n (HT40)	2422 / 2437 / 2452	6.5-39-65Mbps
Conducted Spurious Emissions	11b 11g 11n (HT20)	2412 / 2462 2412 / 2462 2412 / 2462	1-11Mbps 6-24-54Mbps 6.5-39-65Mbps
	11n (HT40)	2422 / 2452	6.5-39-65Mbps
Band-edge Compliance	11b 11g 11n (HT20)	2412 / 2462 2412 / 2462 2412 / 2462	1-11Mbps 6-24-54Mbps 6.5-39-65Mbps
	11n (HT40)	2422 / 2452	6.5-39-65Mbps

### Bluetooth

Test Item	Mode	Test Frequency [MHz]	Data Rate
Spurious Radiated Emissions	CW (continuous wave)	2440	/
Restricted Bands of Operation	8DPSK (BT)	2480	3Mbps (EDR)
	GFSK (BLE)	2480	1Mbps (BR)

### Wi-Fi (WLAN) + Bluetooth

Test Item	Mode	Test Frequency [MHz]	Data Rate
Spurious Radiated Emissions	Hopping (BT)	/	3Mbps (EDR)
	11b (WLAN)	2437	1Mbps
Restricted Bands of Operation	Hopping (BT)	/	3Mbps (EDR)
	11b (WLAN)	2462	11Mbps
AC Conducted Emissions	Hopping (BT)	/	3Mbps (EDR)
	11b (WLAN)	2437	1Mbps

### 3.0 Maximum Conducted Output Power - Condizioni di prova / Test Conditions

Technician / Tecnico: Loris Fruch		
Table No.	TEST: Maximum Conducted Output Power, Section 15.247 (b) (3)	\
Method	FCC KDB 558074 sect. 9.2	\
Parameters required prior to the test	Laboratory Ambient Temperature	18 to 28 °C
	Relative Humidity	20 to 90%
Parameters recorded during the test	Laboratory Ambient Temperature	21 °C
	Relative Humidity	52 - 54 %
Supplementary information:		
<ul style="list-style-type: none"> <li>- Conducted Test, executed at WLAN/Bluetooth antenna output (50ohm, SMA) connected to the Spectrum Analyser through an attenuator (30 dB);</li> <li>- EUT powered at 24Vdc;</li> <li>- EUT Operating Mode: Mode1 (see par. 2.0);</li> <li>- Spectrum analyser settings setup according to FCC KDB 558074 sect. 9.2.2.3 (AVGSA-1):                             <ul style="list-style-type: none"> <li>• Detector: Average(RMS)</li> <li>• RBW: 1MHz and VBW=3MHz</li> <li>• Instrument mode: 'channel power'</li> </ul> </li> <li>- Test executed with the following WLAN settings:                             <ul style="list-style-type: none"> <li>• protocol "b" on channel 1, 6 and 11 with data rate at 1 and 11Mbps</li> <li>• protocol "g" on channel 1, 6 and 11 with data rate at 6, 24 and 54Mbps</li> <li>• protocol "n" 20MHz on channel 1, 6 and 11 with data rate at 6.5, 39 and 65Mbps</li> <li>• protocol "n" 40MHz on channel 3, 6 and 9 with data rate at 6.5, 39 and 65Mbps</li> </ul> </li> </ul>		

### 3.1 Apparecchiature utilizzate / Test Equipment Used – Maximum Conducted Output Power

Apparecchiature usate/Equipment Used	Modello/Model	Costruttore/Manufacturer	Numero di serie/Serial Number	Data calibrazione / Calibration date	Intervallo / Interval
EMI Receiver MXE	N9038A	Agilent Technologies	MY51210230	05/2015	1 year
30dB Attenuator	PE7087-30	Pasternack	EL082315	09/2015	1 year

#### 3.1.1 Apparecchiature ausiliarie / Auxiliary Equipment

Apparecchiature usate / Used Equipment	Modello / Model	Costruttore / Manufacturer	Numero di serie / Serial Number
Access Point	524704	Intellinet	GAP215N16C1800539

### 3.2 Fotografie del setup / Photo of the test setup – Maximum Conducted Output Power

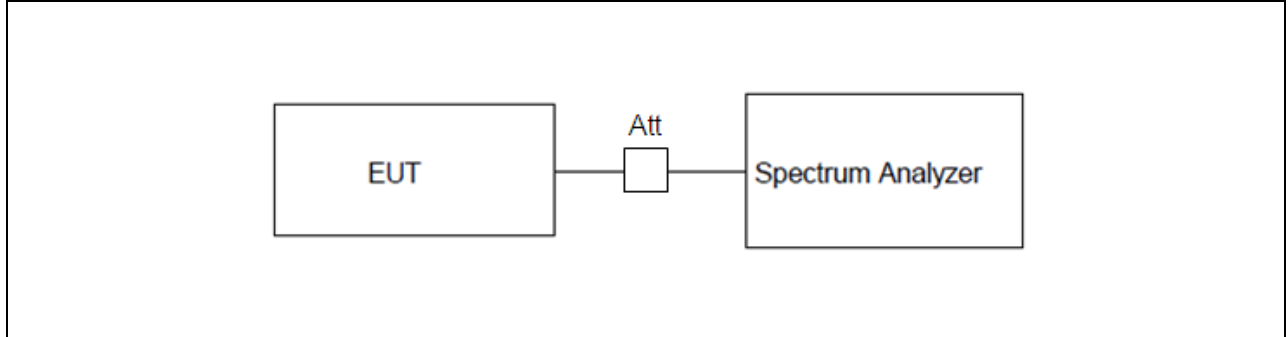

### 3.3 Risultati / Results - Maximum Conducted Output Power

The result of the test is: **PASS**. See the details in the charts/tables of the following paragraphs (see the worst case in bold text).

#### 3.3.1 Tabelle e grafici dei risultati / Tables and graphical representation of data – Maximum Conducted Output Power

##### Measures executed on WLAN

Note: all the traces reported in this section have been obtained with Average(RMS) detector, max hold (over last 30 sweeps), RBW=1MHz.

802.11 Protocol	Data Rate (Mbps)	Channel Frequency (MHz)	Total Power (dBm)	Limit (dBm)	Margin (dB)
b	1	2412.0	<b>26.3</b>	30.0	3.7
		2437.0	26.0	30.0	4.0
		2462.0	25.8	30.0	4.2
	11	2412.0	26.2	30.0	3.8
		2437.0	25.9	30.0	4.1
		2462.0	26.2	30.0	3.8

See traces below:



LAB N° 0986

Channel Frequency: 2462 MHz, Data Rate: 1Mbps



Channel Frequency: 2412 MHz, Data Rate: 11Mbps



Channel Frequency: 2437 MHz, Data Rate: 11Mbps



Channel Frequency: 2462 MHz, Data Rate: 11Mbps

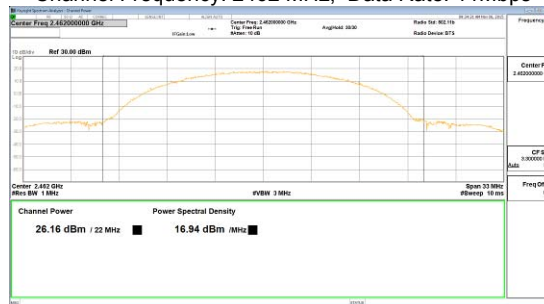



802.11 Protocol	Data Rate (Mbps)	Channel Frequency (MHz)	Total Power (dBm)	Limit (dBm)	Margin (dB)
g	6	2412.0	24.0	30.0	6.0
		2437.0	25.2	30.0	4.8
		2462.0	24.2	30.0	5.9
	24	2412.0	23.3	30.0	6.7
		2437.0	25.5	30.0	4.5
		2462.0	24.2	30.0	5.8
	54	2412.0	25.0	30.0	5.0
		2437.0	25.3	30.0	4.7
		2462.0	23.4	30.0	6.6

See traces below:

Channel Frequency: 2412 MHz, Data Rate: 6Mbps



Channel Frequency: 2437 MHz, Data Rate: 6Mbps



Channel Frequency: 2462 MHz, Data Rate: 6Mbps

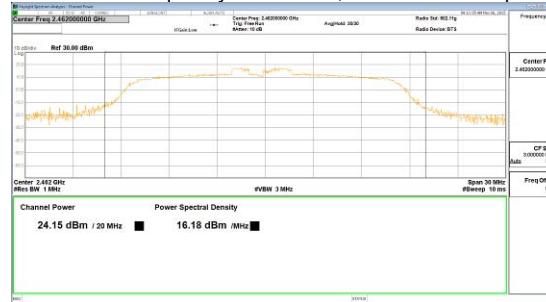

Channel Frequency: 2412 MHz, Data Rate: 24Mbps

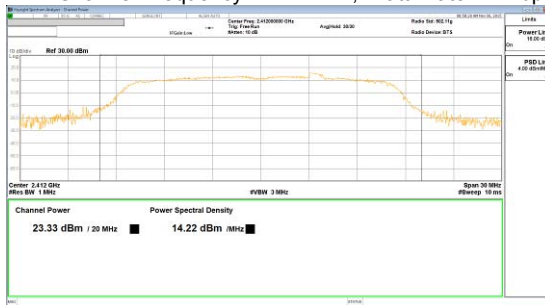

Channel Frequency: 2437 MHz, Data Rate: 24Mbps



Channel Frequency: 2462 MHz, Data Rate: 24Mbps



Channel Frequency: 2412 MHz, Data Rate: 54Mbps

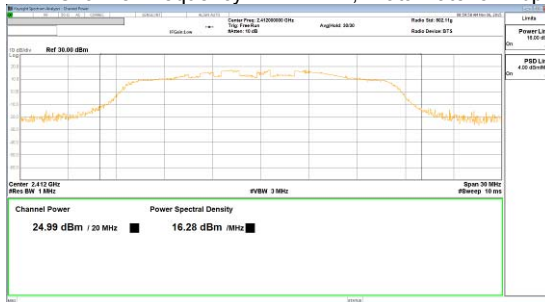

Channel Frequency: 2437 MHz, Data Rate: 54Mbps



Channel Frequency: 2462 MHz, Data Rate: 54Mbps

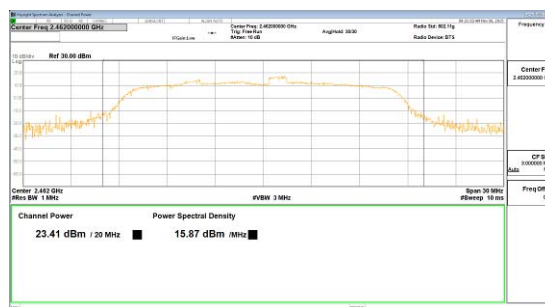

802.11 Protocol	Data Rate (Mbps)	Channel Frequency (MHz)	Total Power (dBm)	Limit (dBm)	Margin (dB)
n 20MHz	6.5 (MCS0)	2412.0	23.5	30.0	6.5
		2437.0	<b>26.3</b>	30.0	3.7
		2462.0	23.3	30.0	6.7
	39 (MCS4)	2412.0	23.4	30.0	6.6
		2437.0	25.3	30.0	4.7
		2462.0	23.1	30.0	6.9
	65 (MCS7)	2412.0	23.2	30.0	6.8
		2437.0	25.3	30.0	4.7
		2462.0	23.0	30.0	7.1

See traces below:

Channel Frequency: 2412 MHz, Data Rate: 6.5Mbps

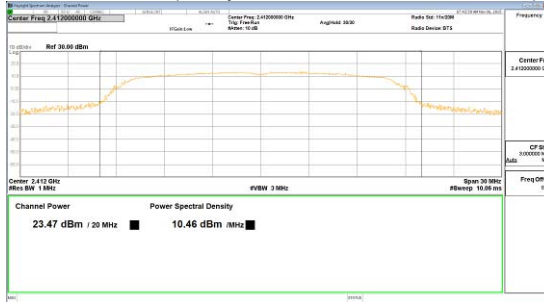

Channel Frequency: 2437 MHz, Data Rate: 6.5Mbps

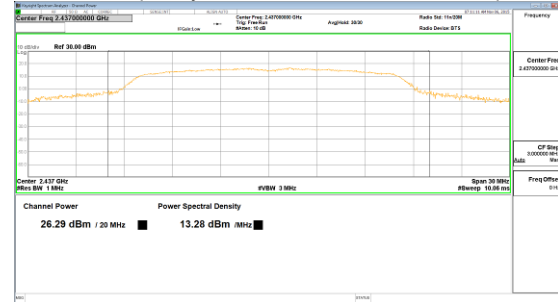

Channel Frequency: 2462 MHz, Data Rate: 6.5Mbps



Channel Frequency: 2412 MHz, Data Rate: 39Mbps

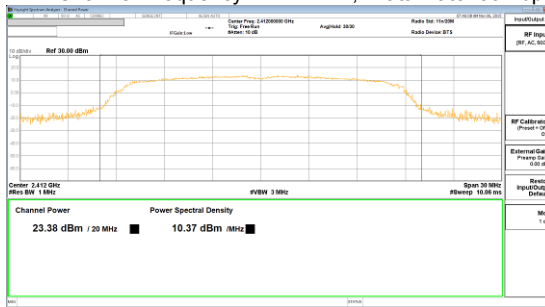

Channel Frequency: 2437 MHz, Data Rate: 39Mbps

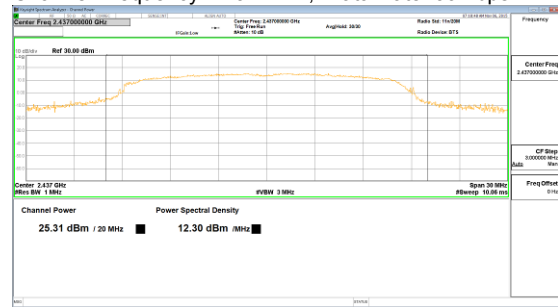

Channel Frequency: 2462 MHz, Data Rate: 39Mbps



Channel Frequency: 2412 MHz, Data Rate: 65Mbps

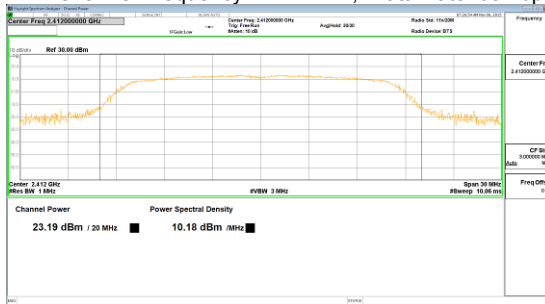

Channel Frequency: 2437 MHz, Data Rate: 65Mbps

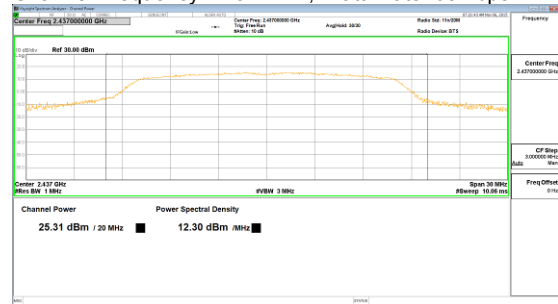

Channel Frequency: 2462 MHz, Data Rate: 65Mbps

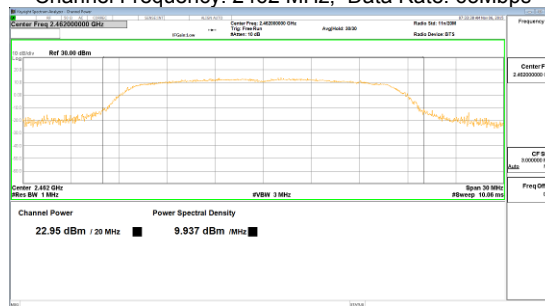

802.11 Protocol	Data Rate (Mbps)	Channel Frequency (MHz)	Total Power (dBm)	Limit (dBm)	Margin (dB)
n 40MHz	6.5 (MCS0)	2422.0	23.9	30.0	6.2
		2437.0	23.7	30.0	6.3
		2452.0	22.7	30.0	7.3
	39 (MCS4)	2422.0	23.9	30.0	6.2
		2437.0	23.7	30.0	6.3
		2452.0	22.9	30.0	7.1
	65 (MCS7)	2422.0	24.0	30.0	6.0
		2437.0	23.6	30.0	6.4
		2452.0	23.3	30.0	6.7

See traces below:

Channel Frequency: 2422 MHz, Data Rate: 6.5Mbps



Channel Frequency: 2437 MHz, Data Rate: 6.5Mbps



Channel Frequency: 2452 MHz, Data Rate: 6.5Mbps



Channel Frequency: 2422 MHz, Data Rate: 39Mbps



Channel Frequency: 2437 MHz, Data Rate: 39Mbps



Channel Frequency: 2452 MHz, Data Rate: 39Mbps



Channel Frequency: 2422 MHz, Data Rate: 65Mbps



Channel Frequency: 2437 MHz, Data Rate: 65Mbps



Channel Frequency: 2452 MHz, Data Rate: 65Mbps



#### 4.0 Maximum Power Spectral Density-Condizioni di prova / Test Conditions

Technician / Tecnico: Loris Fruch		
Table No.	TEST: Maximum Power Spectral Density, Section FCC 15.247(e)	\
Method	FCC KDB 558074 par.10.2 (peak PSD)	\
Parameters required prior to the test	Laboratory Ambient Temperature	18 to 28 °C
	Relative Humidity	20 to 90 %
Parameters recorded during the test	Laboratory Ambient Temperature	21 °C
	Relative Humidity	54 %
Supplementary information:		
<ul style="list-style-type: none"> <li>- Conducted Test, executed at WLAN/BT antenna output (50ohm,SMA) connected to the Spectrum Analyser through an attenuator (30 dB).</li> <li>- EUT powered at 24Vdc;</li> <li>- EUT Operating Mode: Mode1 (see par. 2.0);</li> <li>- Spectrum analyser settings setup according to FCC KDB 558074 sect. 10.2 (peak PSD) Detector: Peak, Trace: max hold (over last 30 sweeps), RBW: 3 kHz, VBW=30 kHz, Sweep Control: auto couple (SR=stimulus/response).</li> <li>- Test executed with the following Wi-Fi settings:               <ul style="list-style-type: none"> <li>• protocol "b" on channel 1, 6 and 11 with data rate at 1 and 11Mbps</li> <li>• protocol "g" on channel 1, 6 and 11 with data rate at 6, 24 and 54Mbps</li> <li>• protocol "n" 20MHz on channel 1, 6 and 11 with data rate at 6.5, 39 and 65Mbps</li> <li>• protocol "n" 40MHz on channel 3, 6 and 9 with data rate at 6.5, 39 and 65Mbps</li> </ul> </li> </ul>		

#### 4.1 Apparecchiature utilizzate / Test Equipment Used – Maximum Peak Conducted Output Power

Apparecchiature usate/Equipment Used	Modello/Model	Costruttore/Manufacturer	Numero di serie/Serial Number	Data calibrazione / Calibration date	Intervallo / Interval
EMI Receiver MXE	N9038A	Agilent Technologies	MY51210230	05/2015	1 year
30dB Attenuator	PE7087-30	Pasternack	EL082315	09/2015	1 year

##### 4.1.1 Apparecchiature ausiliarie / Auxiliary Equipment

Apparecchiature usate / Used Equipment	Modello / Model	Costruttore / Manufacturer	Numero di serie / Serial Number
Access Point	524704	Intellinet	GAP215N16C1800539



## 4.2 Fotografie del setup / Photo of the test setup – Maximum Power Spectral Density

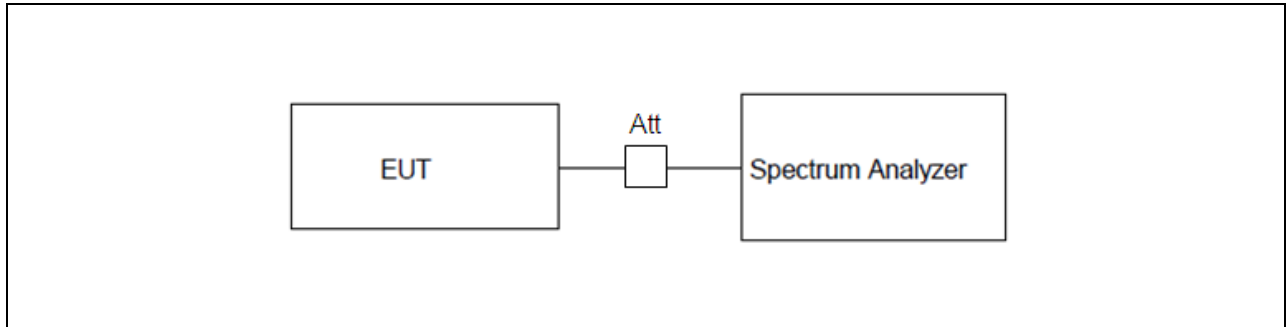

## 4.3 Risultati / Results - Maximum Power Spectral Density

The result of the test is: **PASS**. See the details in the charts/tables of the following paragraphs (see the worst case in bold text).

### 4.3.1 Tabelle e grafici dei risultati / Tables and graphical representation of data – Maximum Power Spectral Density

Note: all the traces reported in this section have been obtained with Peak detector, max hold (over last 100 sweeps); RBW= 10kHz:

#### Measures executed on WLAN

802.11 Protocol	Data Rate (Mbps)	Channel Frequency (MHz)	Total PSD (dBm/3KHz)	Limit (dBm/3KHz)	Margin (dB)
b	1	2412.0	-8.17	8.00	16.2
		2437.0	-8.61	8.00	16.6
		2462.0	<b>-8.07</b>	8.00	16.1
	11	2412.0	<b>-8.07</b>	8.00	16.1
		2437.0	-8.10	8.00	16.1
		2462.0	-8.48	8.00	16.5

See traces below:



Channel Frequency: 2462 MHz, Data Rate: 1Mbps

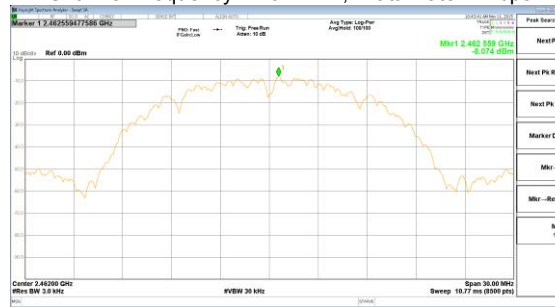

Channel Frequency: 2412 MHz, Data Rate: 11Mbps



Channel Frequency: 2437 MHz, Data Rate: 11Mbps

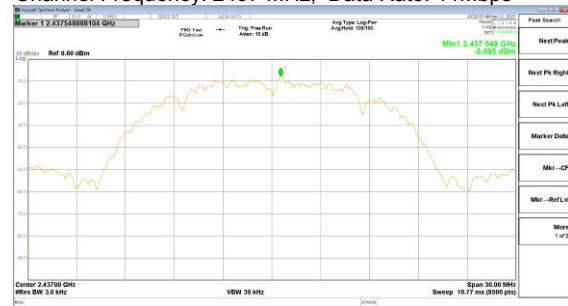

Channel Frequency: 2462 MHz, Data Rate: 11Mbps

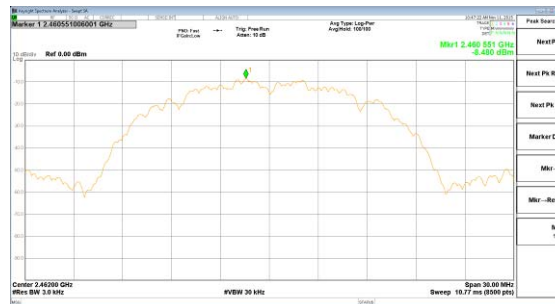

802.11 Protocol	Data Rate (Mbps)	Channel Frequency (MHz)	Total PSD (dBm/3KHz)	Limit (dBm/3KHz)	Margin (dB)
g	6	2412.0	-17.83	8.0	25.8
		2437.0	-15.10	8.0	23.1
		2462.0	-11.15	8.0	19.2
	24	2412.0	-12.16	8.0	20.2
		2437.0	-11.28	8.0	19.3
		2462.0	-8.73	8.0	16.7
	54	2412.0	-10.15	8.0	18.2
		2437.0	-9.65	8.0	17.7
		2462.0	-11.67	8.0	19.7

See traces below:

Channel Frequency: 2412 MHz, Data Rate: 6Mbps

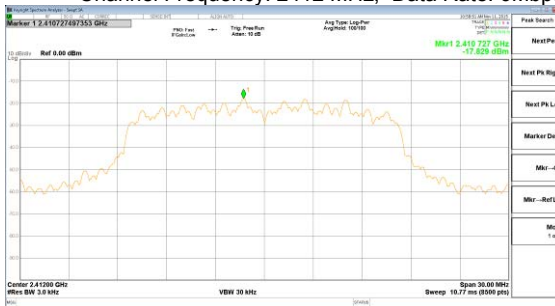

Channel Frequency: 2437 MHz, Data Rate: 6Mbps

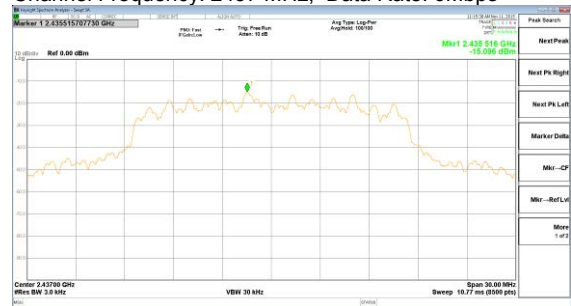

Channel Frequency: 2462 MHz, Data Rate: 6Mbps

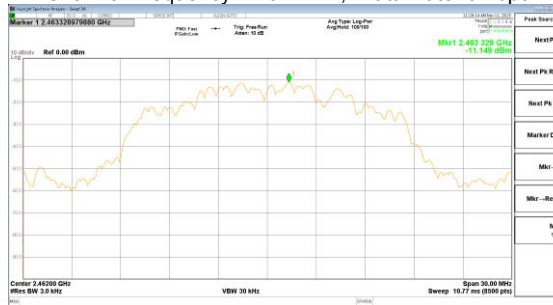

LAB N° 0986

Channel Frequency: 2412 MHz, Data Rate: 24Mbps

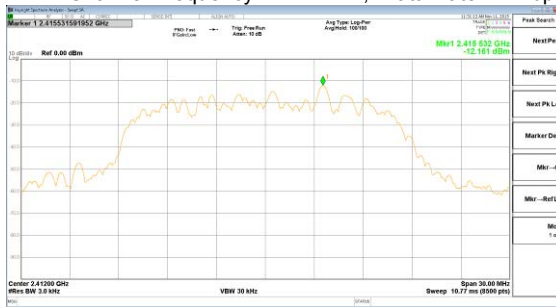

Channel Frequency: 2437 MHz, Data Rate: 24Mbps

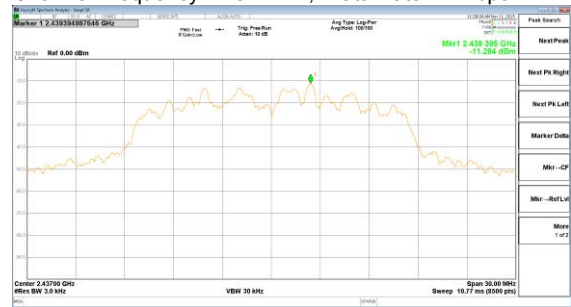

Channel Frequency: 2462 MHz, Data Rate: 24Mbps

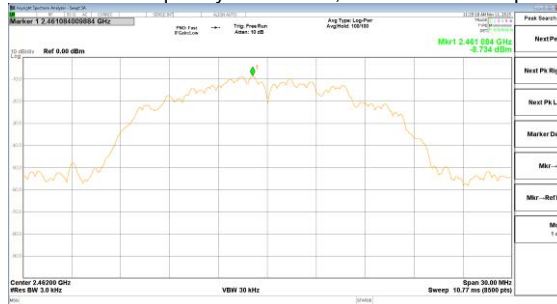

Channel Frequency: 2412 MHz, Data Rate: 54Mbps

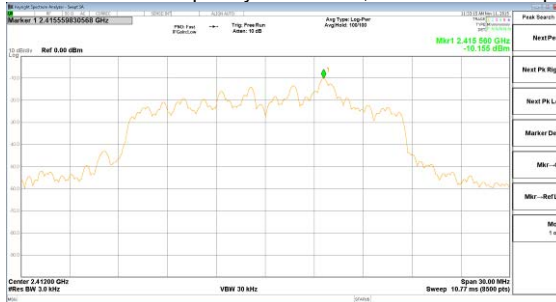

Channel Frequency: 2437 MHz, Data Rate: 54Mbps



Channel Frequency: 2462 MHz, Data Rate: 54Mbps

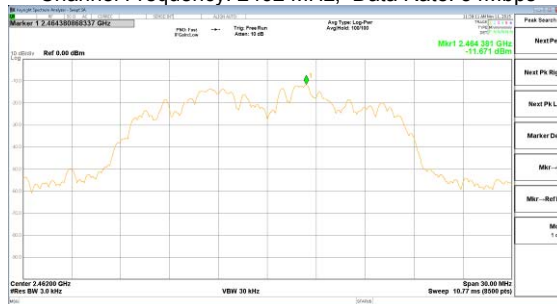

802.11 Protocol	Data Rate (Mbps)	Channel Frequency (MHz)	Total PSD (dBm/3KHz)	Limit (dBm/3KHz)	Margin (dB)
n 20MHz	6.5 (MCS0)	2412.0	-16.74	8.0	24.7
		2437.0	-13.35	8.0	21.4
		2462.0	-14.02	8.0	22.0
	39 (MCS4)	2412.0	-16.90	8.0	24.9
		2437.0	-11.69	8.0	19.7
		2462.0	-11.99	8.0	20.0
	65 (MCS7)	2412.0	-16.68	8.0	24.7
		2437.0	-14.47	8.0	22.5
		2462.0	-16.33	8.0	24.3

See traces below:

Channel Frequency: 2412 MHz, Data Rate: 6.5Mbps

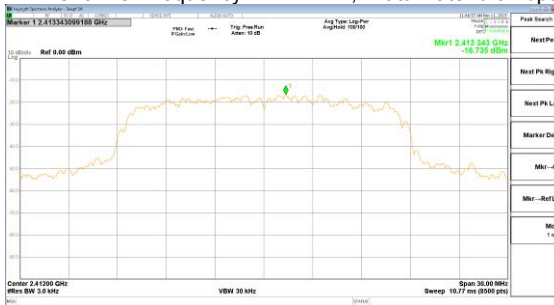

Channel Frequency: 2437 MHz, Data Rate: 6.5Mbps



Channel Frequency: 2462 MHz, Data Rate: 6.5Mbps

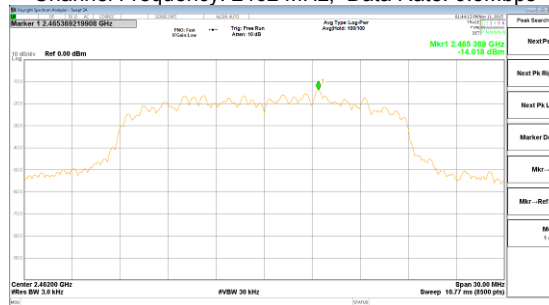

LAB N° 0986

Channel Frequency: 2412 MHz, Data Rate: 39Mbps

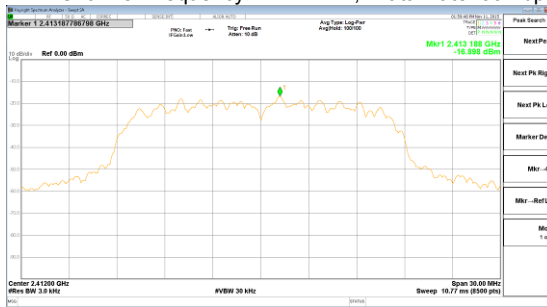

Channel Frequency: 2437 MHz, Data Rate: 39Mbps

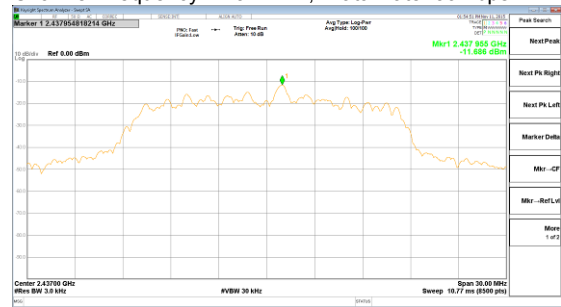

Channel Frequency: 2462 MHz, Data Rate: 39Mbps

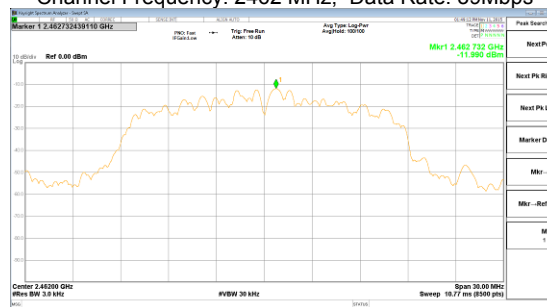

Channel Frequency: 2412 MHz, Data Rate: 65Mbps

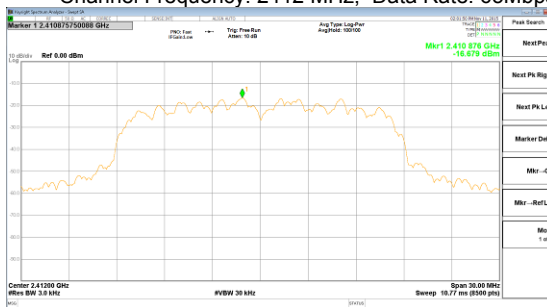

Channel Frequency: 2437 MHz, Data Rate: 65Mbps

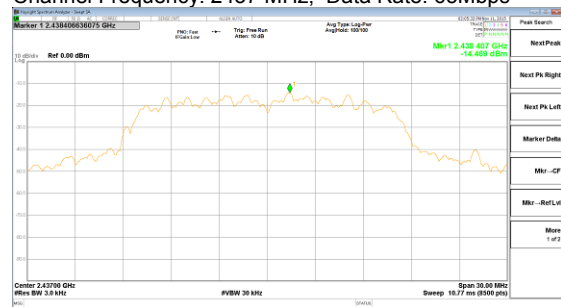

Channel Frequency: 2462 MHz, Data Rate: 65Mbps

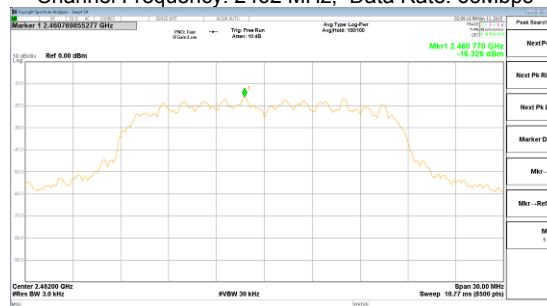

802.11 Protocol	Data Rate (Mbps)	Channel Frequency (MHz)	Total PSD (dBm/3KHz)	Limit (dBm/3KHz)	Margin (dB)
n 40MHz	6.5 (MCS0)	2422.0	-17.01	8.0	25.0
		2437.0	-17.01	8.0	25.0
		2452.0	-17.23	8.0	25.2
	39 (MCS4)	2422.0	-13.35	8.0	21.4
		2437.0	-17.81	8.0	25.8
		2452.0	-15.49	8.0	23.5
	65 (MCS7)	2422.0	-16.59	8.0	24.6
		2437.0	-19.27	8.0	27.3
		2452.0	-13.26	8.0	21.3

See traces below:

Channel Frequency: 2422 MHz, Data Rate: 6.5Mbps



Channel Frequency: 2437 MHz, Data Rate: 6.5Mbps



Channel Frequency: 2452 MHz, Data Rate: 6.5Mbps

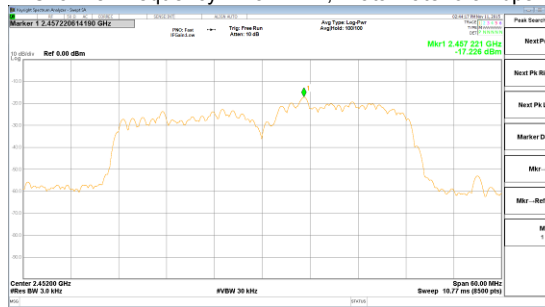



LAB N° 0986

Channel Frequency: 2422 MHz, Data Rate: 39Mbps



Channel Frequency: 2437 MHz, Data Rate: 39Mbps

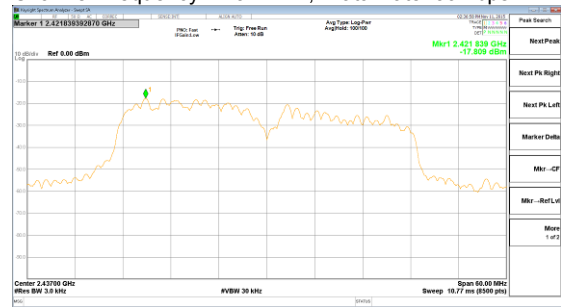

Channel Frequency: 2452 MHz, Data Rate: 39Mbps



Channel Frequency: 2422 MHz, Data Rate: 65Mbps



Channel Frequency: 2437 MHz, Data Rate: 65Mbps

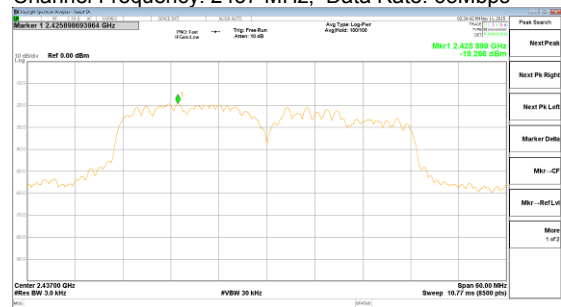

Channel Frequency: 2452 MHz, Data Rate: 65Mbps

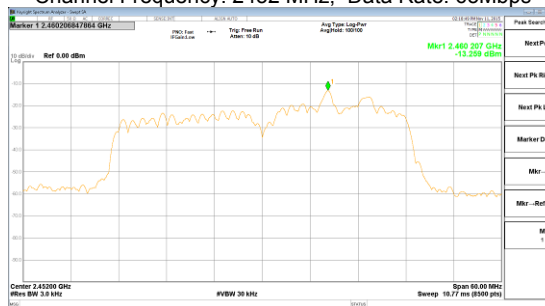

## 5.0 Bandwidth - Condizioni di prova / Test Conditions

Technician / Tecnico: Loris Fruch		
Table No.	TEST: 6 dB Bandwidth, Section 15.247 (a) (2) for WLAN	\
Method	FCC KDB 558074, par. 8.2	\
Parameters required prior to the test	Laboratory Ambient Temperature	18 to 28 °C
	Relative Humidity	20 to 90 %
Parameters recorded during the test	Laboratory Ambient Temperature	20 °C
	Relative Humidity	51 %
Supplementary information:		
<ul style="list-style-type: none"> <li>- Conducted Test, executed at WLAN/Bluetooth antenna output (50ohm,SMA) connected to the Spectrum Analyser through an attenuator (30 dB);</li> <li>- EUT powered at 24Vdc;</li> <li>- EUT Operating Mode: Mode1 (see par. 2.0);</li> <li>- Spectrum analyser settings setup according to FCC KDB 558074 sect. 8.2 (automatic bandwidth measurement) Detector: Peak, Trace: max hold (over last 10 sweeps),</li> <li>- RBW: 430 kHz for WLAN protocol "b" and 100KHz for WLAN protocol "g" and "n"</li> <li>- VBW=3xRBW;</li> <li>- Test executed with the following WLAN settings:               <ul style="list-style-type: none"> <li>• protocol "b" on channel 1, 6 and 11 with data rate at 1 and 11Mbps</li> <li>• protocol "g" on channel 1, 6 and 11 with data rate at 6, 24 and 54Mbps</li> <li>• protocol "n" 20MHz on channel 1, 6 and 11 with data rate at 6.5, 39 and 65Mbps</li> <li>• protocol "n" 40MHz on channel 3, 6 and 9 with data rate at 6.5, 39 and 65Mbps</li> </ul> </li> </ul>		

## 5.1 Apparecchiature utilizzate / Test Equipment Used – Maximum Peak Conducted Output Power

Apparecchiature usate/Equipment Used	Modello/Model	Costruttore/Manufacturer	Numero di serie/Serial Number	Data calibrazione / Calibration date	Intervallo / Interval
EMI Receiver MXE	N9038A	Agilent Technologies	MY51210230	05/2015	1 year
30dB Attenuator	PE7087-30	Pasternack	EL082315	09/2015	1 year

### 5.1.1 Apparecchiature ausiliarie / Auxiliary Equipment

Apparecchiature usate / Used Equipment	Modello / Model	Costruttore /Manufacturer	Numero di serie / Serial Number
Access Point	524704	Intellinet	GAP215N16C1800539

## 5.2 Fotografie del setup / Photo of the test setup –Bandwidth

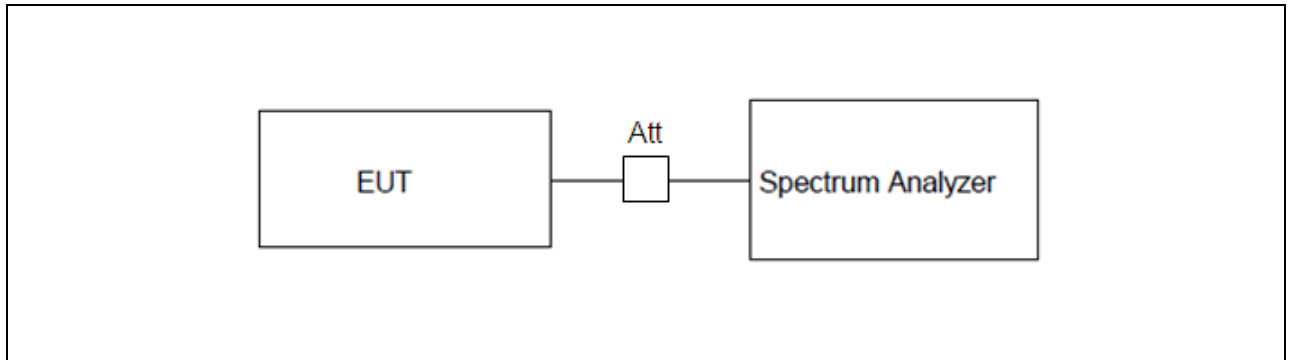

## 5.3 Risultati / Results - Bandwidth

Section 15.247 (a) (2) The minimum specified 6dB bandwidth for digital modulated is 500 kHz, thus the result of the test is: **PASS**. See the details in the charts/tables of the following paragraphs.

### 5.3.1 Tabelle e grafici dei risultati / Tables and graphical representation data – Bandwidth

#### Measures executed on WLAN

802.11 Protocol	Data Rate (Mbps)	Channel Frequency (MHz)	6 dB Bandwidth (MHz)	99% OBW (MHz)
b	1	2412.0	9.2	14.6
		2437.0	9.6	14.6
		2462.0	10.4	14.7
	11	2412.0	9.8	14.7
		2437.0	9.2	14.8
		2462.0	10.0	14.7

See traces below:

Channel Frequency: 2412 MHz, Data Rate: 1Mbps Channel Frequency: 2437 MHz, Data Rate: 1Mbps

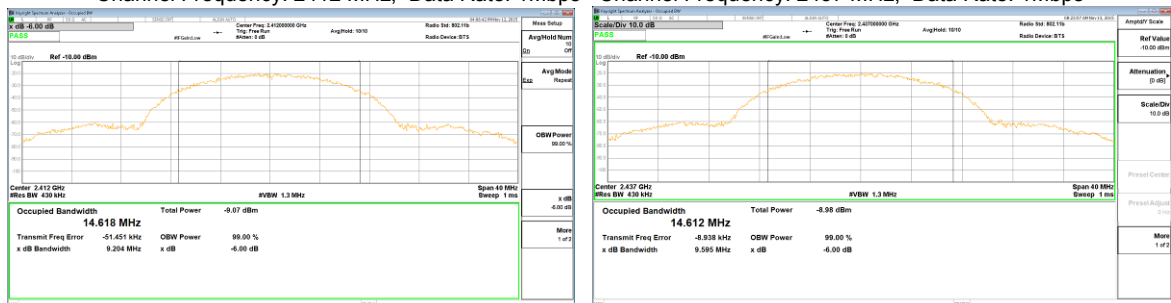

LAB N° 0986

Channel Frequency: 2462 MHz, Data Rate: 1Mbps



Channel Frequency: 2412 MHz, Data Rate: 11Mbps Channel Frequency: 2437 MHz, Data Rate: 11Mbps

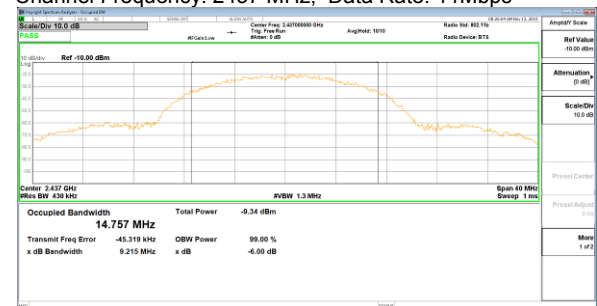
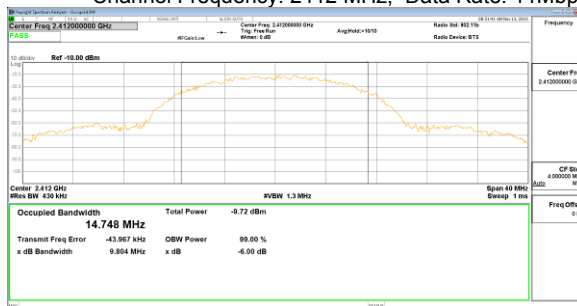

Channel Frequency: 2462 MHz, Data Rate: 11Mbps

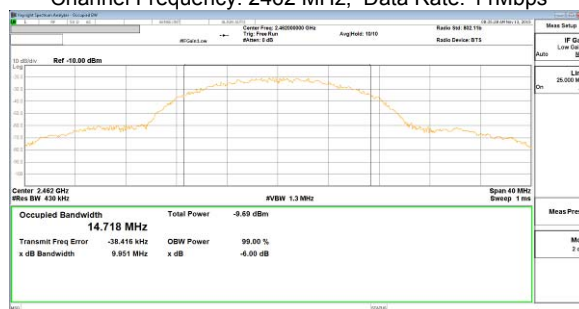

802.11 Protocol	Data Rate (Mbps)	Channel Frequency (MHz)	6 dB Bandwidth (MHz)	99% OBW (MHz)
g	6	2412.0	15.1	16.2
		2437.0	15.1	16.3
		2462.0	15.1	16.2
	24	2412.0	15.1	16.2
		2437.0	15.1	16.3
		2462.0	15.1	16.3
	54	2412.0	13.9	16.2
		2437.0	15.1	16.3
		2462.0	15.1	16.2

See traces below:

Channel Frequency: 2412 MHz, Data Rate: 6Mbps      Channel Frequency: 2437 MHz, Data Rate: 6Mbps

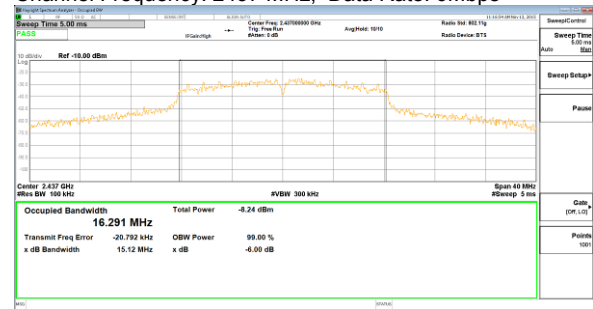
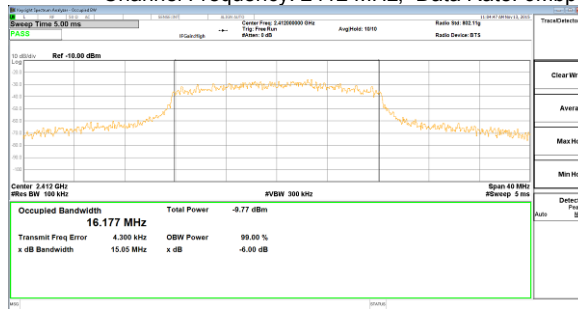

Channel Frequency: 2462 MHz, Data Rate: 6Mbps

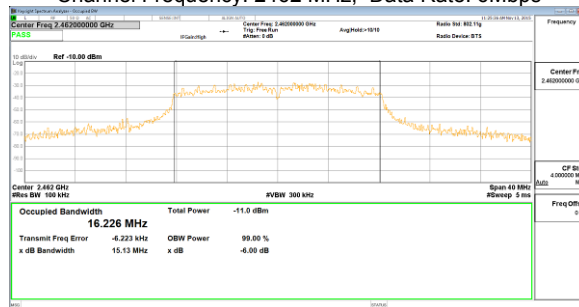

LAB N° 0986

Channel Frequency: 2412 MHz, Data Rate: 24Mbps

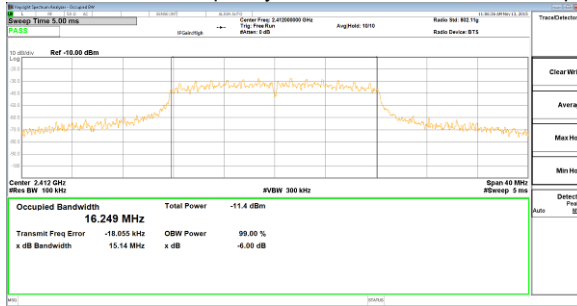

Channel Frequency: 2437 MHz, Data Rate: 24Mbps

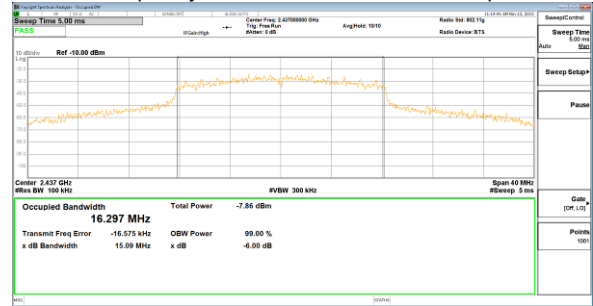

Channel Frequency: 2462 MHz, Data Rate: 24Mbps

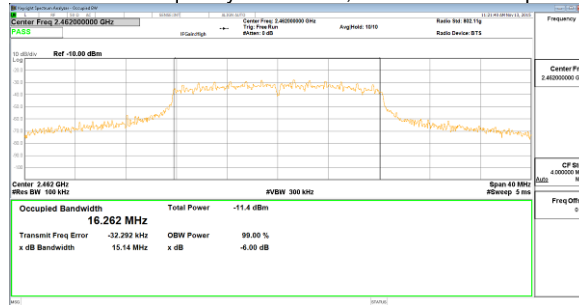

Channel Frequency: 2412 MHz, Data Rate: 54Mbps



Channel Frequency: 2437 MHz, Data Rate: 54Mbps

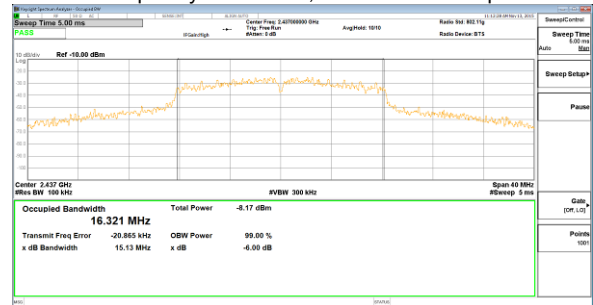

Channel Frequency: 2462 MHz, Data Rate: 54Mbps

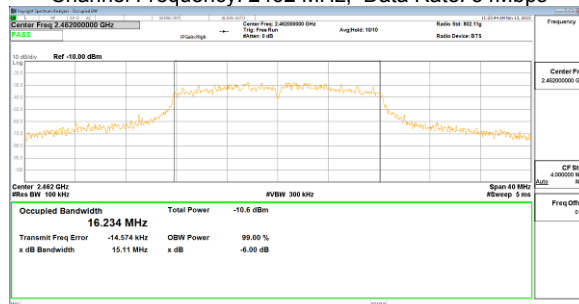

802.11 Protocol	Data Rate (Mbps)	Channel Frequency (MHz)	6 dB Bandwidth (MHz)	99% OBW (MHz)
n 20MHz	6.5 (MCS0)	2412.0	15.1	16.8
		2437.0	15.1	17.8
		2462.0	15.1	16.8
	39 (MCS4)	2412.0	12.6	16.3
		2437.0	15.1	16.6
		2462.0	11.3	16.7
	65 (MCS7)	2412.0	11.3	16.7
		2437.0	10.0	16.7
		2462.0	15.1	16.8

See traces below:

Channel Frequency: 2412 MHz, Data Rate: 6.5Mbps      Channel Frequency: 2437 MHz, Data Rate: 6.5Mbps

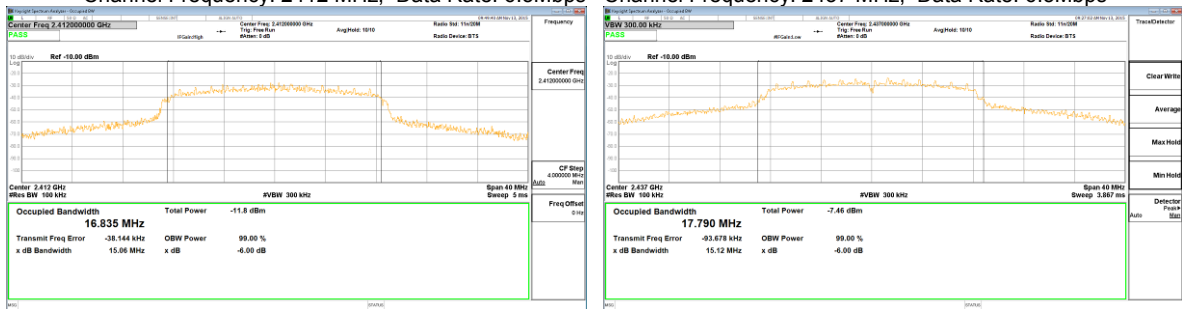

Channel Frequency: 2462 MHz, Data Rate: 6.5Mbps





LAB N° 0986

Channel Frequency: 2412 MHz, Data Rate: 39Mbps

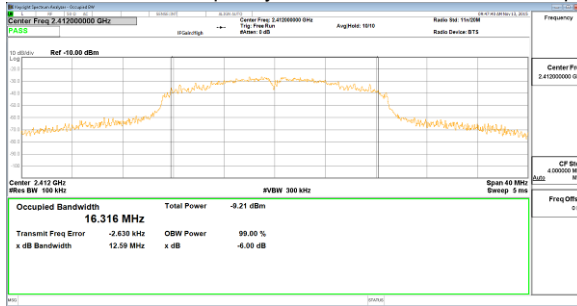

Channel Frequency: 2437 MHz, Data Rate: 39Mbps

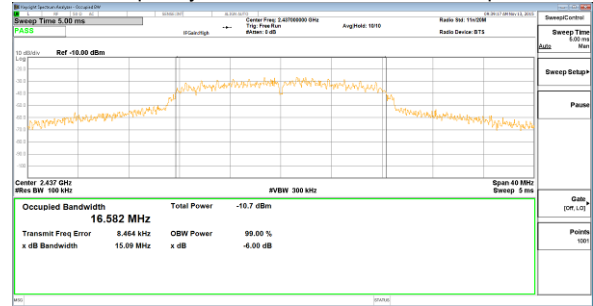

Channel Frequency: 2462 MHz, Data Rate: 39Mbps



Channel Frequency: 2412 MHz, Data Rate: 65Mbps

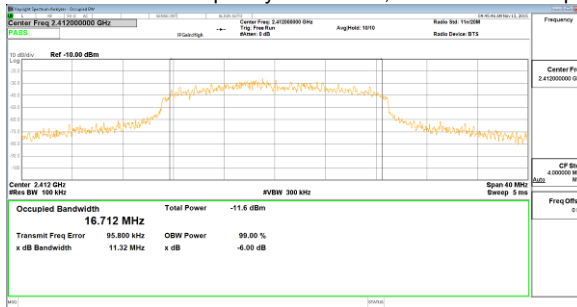

Channel Frequency: 2437 MHz, Data Rate: 65Mbps

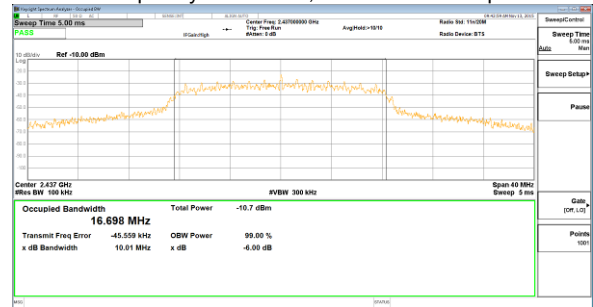

Channel Frequency: 2462 MHz, Data Rate: 65Mbps



802.11 Protocol	Data Rate (Mbps)	Channel Frequency (MHz)	6 dB Bandwidth (MHz)	99% OBW (MHz)
n 40MHz	6.5 (MCS0)	2422.0	30.1	35.5
		2437.0	29.1	35.6
		2452.0	25.1	35.5
	39 (MCS4)	2422.0	20.1	35.6
		2437.0	28.9	35.5
		2452.0	26.4	35.5
	65 (MCS7)	2422.0	26.4	35.5
		2437.0	31.4	35.6
		2452.0	28.9	35.6

See traces below:

Channel Frequency: 2422 MHz, Data Rate: 6.5Mbps      Channel Frequency: 2437 MHz, Data Rate: 6.5Mbps

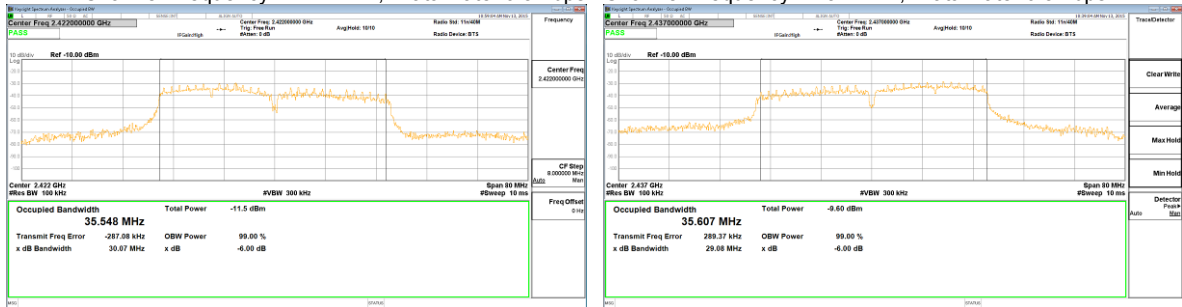

Channel Frequency: 2452 MHz, Data Rate: 6.5Mbps

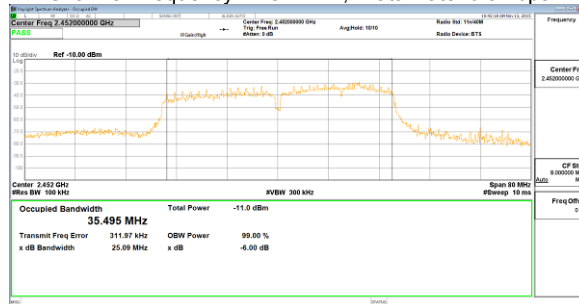

LAB N° 0986

Channel Frequency: 2422 MHz, Data Rate: 39Mbps

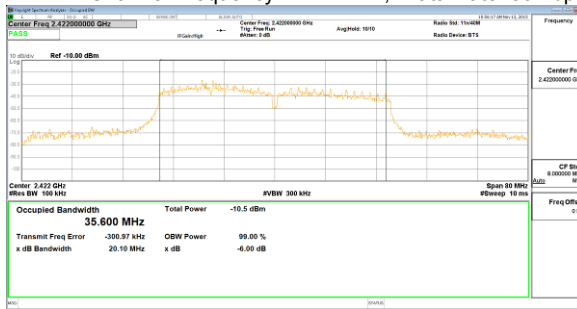

Channel Frequency: 2437 MHz, Data Rate: 39Mbps

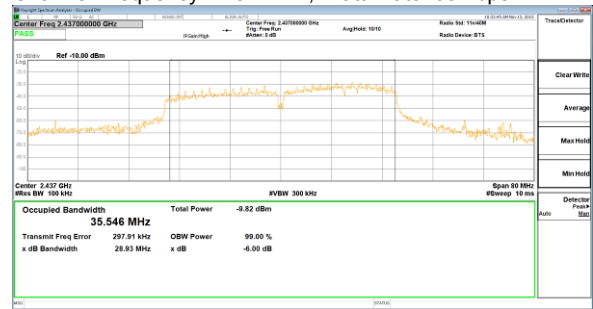

Channel Frequency: 2452 MHz, Data Rate: 39Mbps

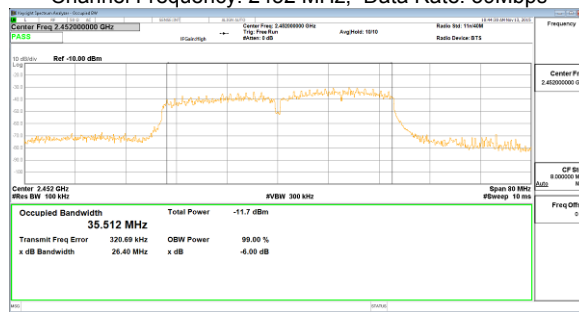

Channel Frequency: 2422 MHz, Data Rate: 65Mbps

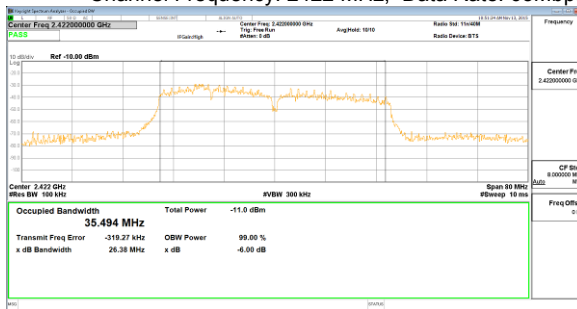

Channel Frequency: 2437 MHz, Data Rate: 65Mbps

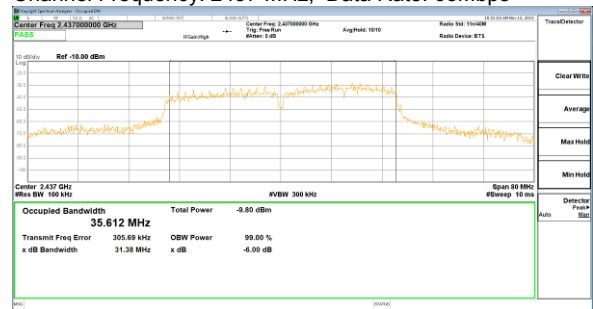

Channel Frequency: 2452 MHz, Data Rate: 65Mbps

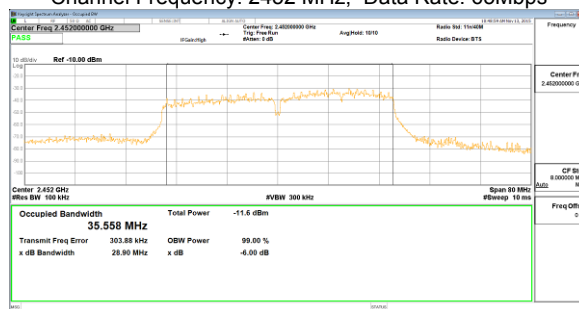

## 6.0 Band-edge Compliance - Condizioni di prova / Test Conditions

Technician / Tecnico: Loris Fruch		
Table No.	TEST: Band-edge Compliance, Section 15.247(d)	\
Method	FCC KDB 558074 par.13.2 (marker delta method)	\
Parameters required prior to the test	Laboratory Ambient Temperature	18 to 28 °C
	Relative Humidity	20 to 90 %
Parameters recorded during the test	Laboratory Ambient Temperature	20 °C
	Relative Humidity	58 %
Supplementary information:		
<ul style="list-style-type: none"> <li>- Conducted Test, executed at WLAN/Bluetooth antenna output (50ohm, SMA) connected to the Spectrum Analyser through an attenuator (30 dB);</li> <li>- EUT powered at 24Vdc;</li> <li>- EUT Operating Mode: Mode1 (see par. 2.0);</li> <li>- Spectrum analyser settings setup according to FCC KDB 558074 sect. 13.2 (marker delta method) Detector: Peak, Trace: max hold (over last 100 sweeps), RBW: 100 kHz, VBW=300 kHz;</li> <li>- Applicable limit: 30dBc (output power conformity assessed using average detector);</li> <li>- Test executed with the following Wi-Fi settings:               <ul style="list-style-type: none"> <li>• protocol "b" on channel 1 and 11 with data rate at 1 and 11Mbps</li> <li>• protocol "g" on channel 1 and 11 with data rate at 6, 24 and 54Mbps</li> <li>• protocol "n" 20MHz on channel 1 and 11 with data rate at 6.5, 39 and 65Mbps</li> <li>• protocol "n" 40MHz on channel 3 and 9 with data rate at 6.5, 39 and 65Mbps</li> </ul> </li> </ul>		

## 6.1 Apparecchiature utilizzate / Test Equipment Used – Maximum Peak Conducted Output Power

Apparecchiature usate/Equipment Used	Modello/Model	Costruttore/Manufacturer	Numero di serie/Serial Number	Data calibrazione / Calibration date	Intervallo / Interval
EMI Receiver MXE	N9038A	Agilent Technologies	MY51210230	05/2015	1 year
30dB Attenuator	PE7087-30	Pasternack	EL082315	09/2015	1 year

### 6.1.1 Apparecchiature ausiliarie / Auxiliary Equipment

Apparecchiature usate / Used Equipment	Modello / Model	Costruttore / Manufacturer	Numero di serie / Serial Number
Access Point	524704	Intellinet	GAP215N16C1800539

## 6.2 Fotografie del setup / *Photo of the test setup* –Band-edge Compliance

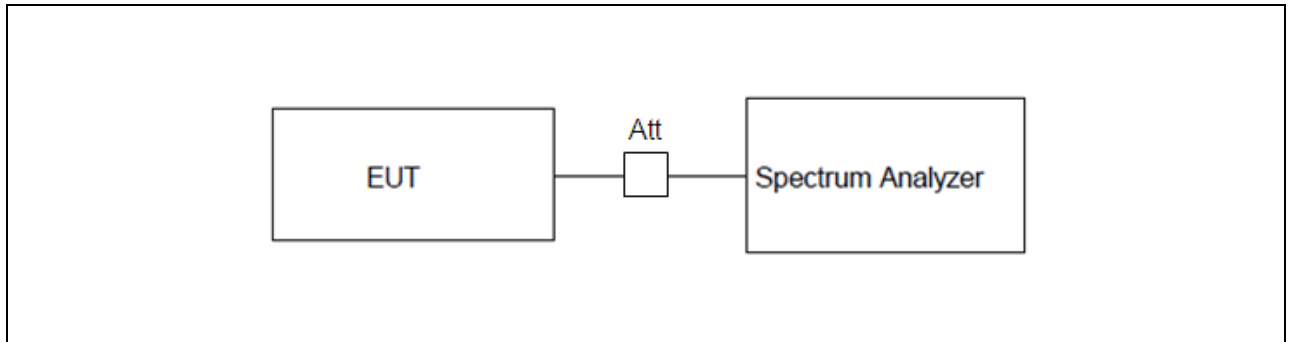

## 6.3 Risultati / *Results* - Band-edge Compliance

The result of the test is: **PASS** .See the details in the charts/tables of the following paragraphs (see the worst case in bold text).

### 6.3.1 Tabelle e grafici dei risultati / Tables and graphical representation of data – Band-edge Compliance

#### Measures executed on WLAN

802.11 Protocol	Data Rate (Mbps)	Max Signal Frequency (MHz)	Max Signal (dBm)	Frequency of Max OOB signal (MHz)	Max OOB Signal (dBm)	Value (dBc)	Limit (dBc)
b	1	2412.1	-25.0	2397.0	-64.60	39.6	30.0
		2462.7	-24.2	2487.5	-79.31	55.1	30.0
	11	2414.1	-24.5	2397.1	-63.95	39.5	30.0
		2460.9	-25.1	2487.5	-78.41	53.3	30.0

Channel Frequency: 2412 MHz, Data Rate: 1Mbps



Channel Frequency: 2462 MHz, Data Rate: 1Mbps

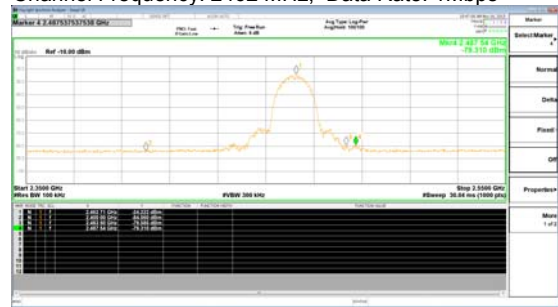

Channel Frequency: 2412 MHz, Data Rate: 11Mbps

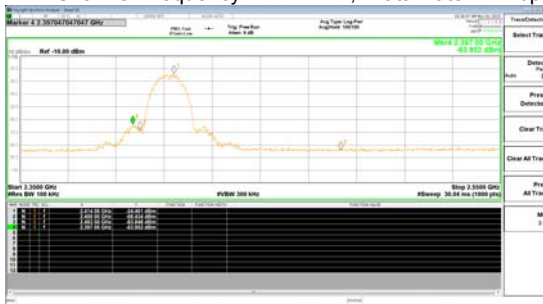

Channel Frequency: 2462 MHz, Data Rate: 11Mbps

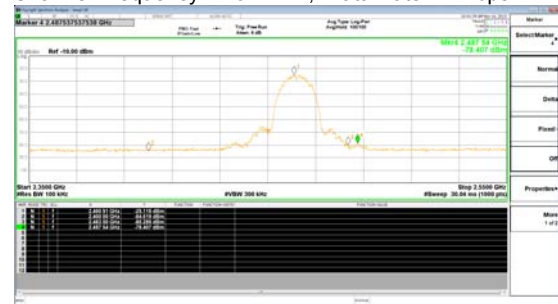

802.11 Protocol	Data Rate (Mbps)	Max Signal Frequency (MHz)	Max Signal (dBm)	Frequency of Max OOB signal (MHz)	Max OOB Signal (dBm)	Value (dBc)	Limit (dBc)
g	6	2411.3	-25.9	2400.0	-62.37	36.4	30.0
		2462.5	-26.5	2483.5	-73.27	46.8	30.0
	24	2410.9	-25.1	2498.7	-59.03	33.9	30.0
		2462.1	-27.1	2483.5	-72.28	45.1	30.0
	54	2413.5	-26.4	2398.3	-63.00	36.6	30.0
		2460.9	-25.4	2485.1	-70.44	45.0	30.0

Channel Frequency: 2412 MHz, Data Rate: 6Mbps

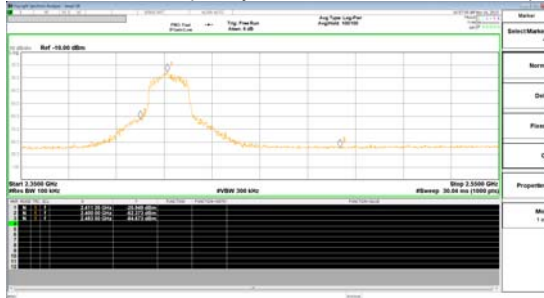

Channel Frequency: 2462 MHz, Data Rate: 6Mbps

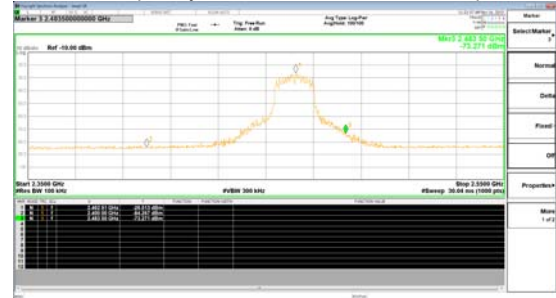

Channel Frequency: 2412 MHz, Data Rate: 24Mbps

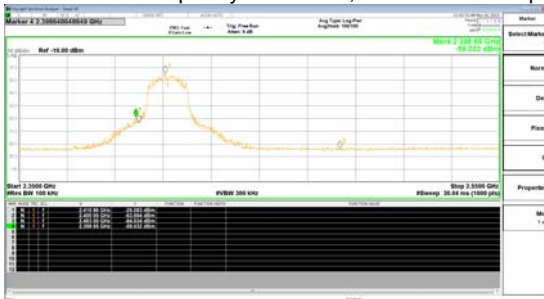

Channel Frequency: 2462 MHz, Data Rate: 24Mbps

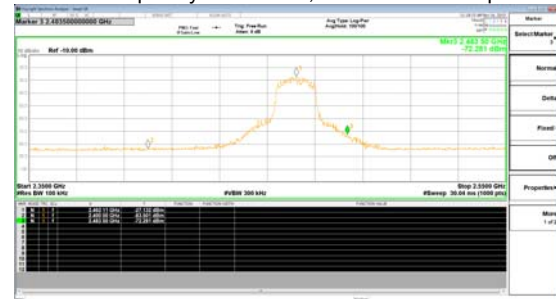

Channel Frequency: 2412 MHz, Data Rate: 54Mbps



Channel Frequency: 2462 MHz, Data Rate: 54Mbps

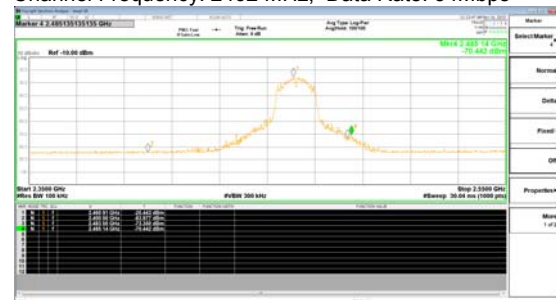



802.11 Protocol	Data Rate (Mbps)	Max Signal Frequency (MHz)	Max Signal (dBm)	Frequency of Max OOB signal (MHz)	Max OOB Signal (dBm)	Value (dBc)	Limit (dBc)
n 20MHz	6.5 (MCS0)	2413.3	-27.8	2398.5	-58.58	<b>30.8</b>	30.0
		2463.3	-28.1	2483.5	-72.83	44.7	30.0
	39 (MCS4)	2413.3	-28.1	2398.7	-58.94	<b>30.8</b>	30.0
		2463.3	-28.4	2485.5	-72.28	43.9	30.0
	65 (MCS7)	2413.3	-28.1	2396.5	-60.54	32.5	30.0
		2463.6	-28.3	2484.5	-70.04	41.7	30.0

Channel Frequency: 2412 MHz, Data Rate: 6.5Mbps

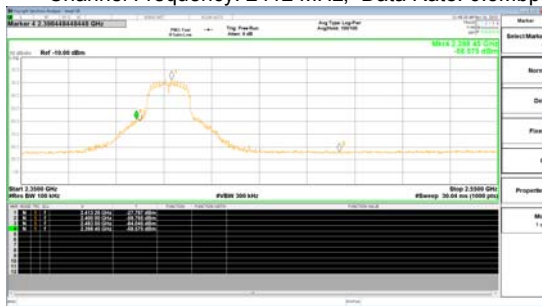

Channel Frequency: 2462 MHz, Data Rate: 6.5Mbps

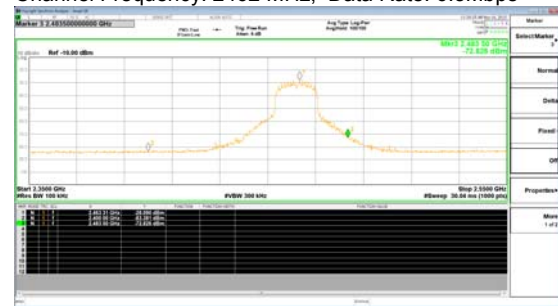

Channel Frequency: 2412 MHz, Data Rate: 39Mbps

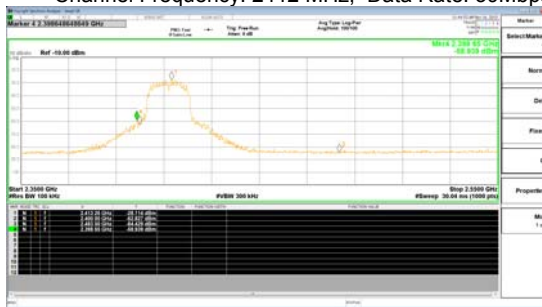

Channel Frequency: 2462 MHz, Data Rate: 39Mbps

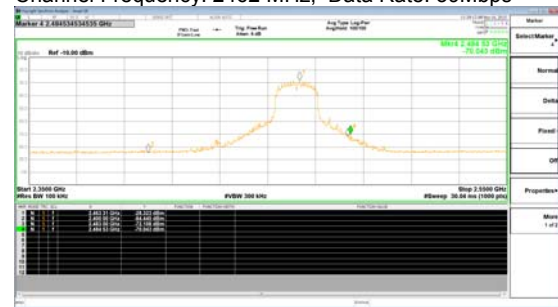

Channel Frequency: 2412 MHz, Data Rate: 65Mbps

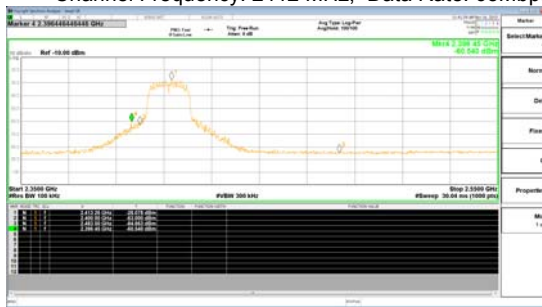

Channel Frequency: 2462 MHz, Data Rate: 65Mbps

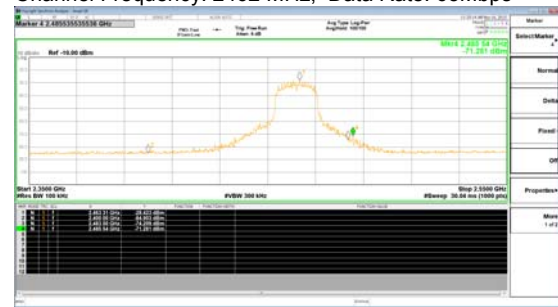



802.11 Protocol	Data Rate (Mbps)	Max Signal Frequency (MHz)	Max Signal (dBm)	Frequency of Max OOB signal (MHz)	Max OOB Signal (dBm)	Value (dBc)	Limit (dBc)
n 40MHz	6.5 (MCS0)	2433.3	-28.8	2393.0	-61.56	32.8	30.0
		2463.3	-30.5	2483.5	-72.13	41.6	30.0
	39 (MCS4)	2431.1	-28.2	2394.4	-66.35	38.1	30.0
		2463.3	-30.6	2487.1	-71.69	41.1	30.0
	65 (MCS7)	2433.3	-28.7	2393.8	-60.75	32.1	30.0
		2463.3	-30.6	2486.3	-68.97	38.4	30.0

Channel Frequency: 2422 MHz, Data Rate: 6.5Mbps



Channel Frequency: 2452 MHz, Data Rate: 6.5Mbps

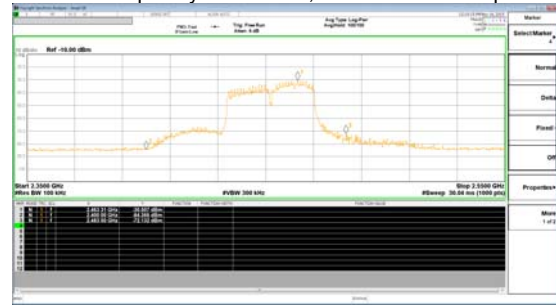

Channel Frequency: 2422 MHz, Data Rate: 39Mbps

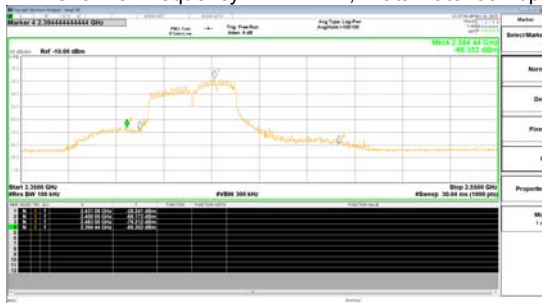

Channel Frequency: 2452 MHz, Data Rate: 39Mbps

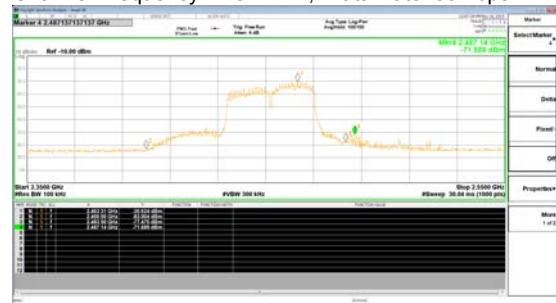

Channel Frequency: 2422 MHz, Data Rate: 65Mbps

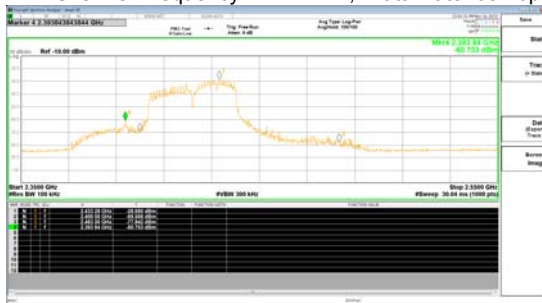

Channel Frequency: 2452 MHz, Data Rate: 65Mbps

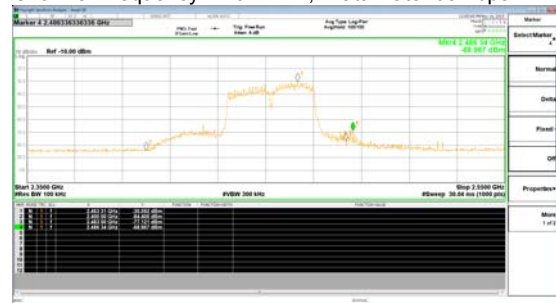

## 7.0 Conducted Spurious Emissions -Condizioni di prova / Test Conditions

Technician / Tecnico: Loris Fruch		
Table No.	TEST: Conducted Spurious Emissions, Section 15.247 (d)	\
Method	KDB_558074 sect. 11.0	\
Parameters required prior to the test	Laboratory Ambient Temperature	18 to 28 °C
	Relative Humidity	20 to 90 %
Parameters recorded during the test	Laboratory Ambient Temperature	21°C
	Relative Humidity	56 %
Supplementary information:		
<ul style="list-style-type: none"> <li>- Conducted Test, executed at WLAN/Bluetooth antenna output (50ohm, SMA) connected to the Spectrum Analyser through an attenuator (30 dB);</li> <li>- Frequency range of the measurements: up to 26GHz.</li> <li>- EUT powered at 24Vdc;</li> <li>- EUT Operating Mode: Mode1(see par. 2.0);</li> <li>- Spectrum analyser settings setup according to FCC KDB 558074 sect. 11.0 (peak detection): Detector= Peak, Trace= max hold (over last 20 sweeps), RBW= 100 kHz, VBW=300 kHz,</li> <li>- Test aim is to verify that in any 100 kHz bandwidth outside the frequency band in which the digitally modulated intentional radiator is operating, the radio frequency power that is produced by the intentional radiator is at least 30 dB below that in the 100 kHz bandwidth within the band that contains the highest level of the desired power.</li> <li>- Test executed with the following Wi-Fi settings:             <ul style="list-style-type: none"> <li>• protocol "b" on channel 1 and 11 with data rate at 1 and 11Mbps</li> <li>• protocol "g" on channel 1 and 11 with data rate at 6, 24 and 54Mbps</li> <li>• protocol "n" 20MHz on channel 1 and 11 with data rate at 6.5, 39 and 65Mbps</li> <li>• protocol "n" 40MHz on channel 3 and 9 with data rate at 6.5, 39 and 65Mbps</li> </ul> </li> </ul>		

## 7.1 Apparecchiature utilizzate / Test Equipment Used – Maximum Peak Conducted Output Power

Apparecchiature usate/Equipment Used	Modello/Model	Costruttore/Manufacturer	Numero di serie/Seria Number	Data calibrazione / Calibration date	Intervallo / Interval
EMI Receiver MXE	N9038A	Agilent Technologies	MY51210230	05/2015	1 year
30dB Attenuator	PE7087-30	Pasternack	EL082315	09/2015	1 year

### 7.1.1 Apparecchiature ausiliarie / Auxiliary Equipment

Apparecchiature usate / Used Equipment	Modello / Model	Costruttore / Manufacturer	Numero di serie / Serial Number
Access Point	524704	Intellinet	GAP215N16C1800539

## 7.2 Fotografie del setup / *Photo of the test setup* –Conducted Spurious Emissions

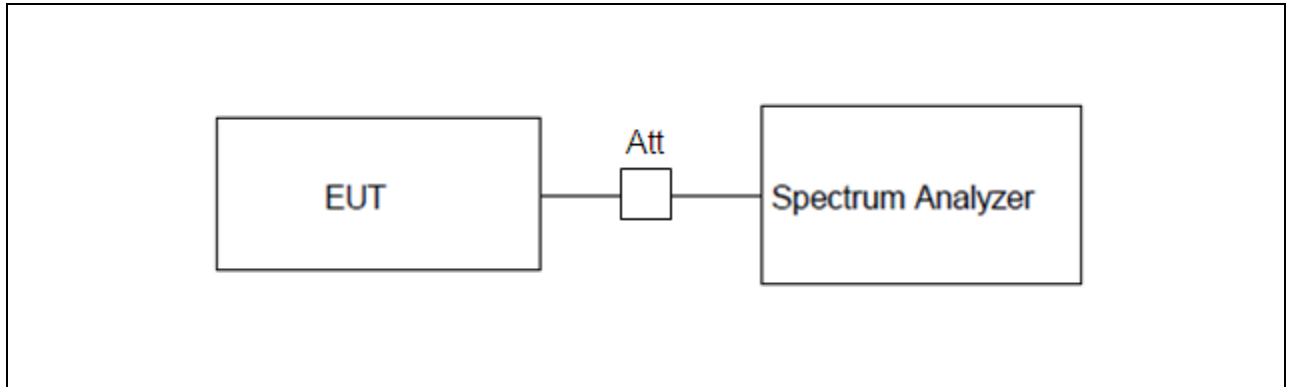

## 7.3 Risultati / *Results* - Conducted Spurious Emissions

The amplitude of spurious emissions is lower than 30 dBc, thus the result of the test is: **PASS**. See the details in the charts of the following paragraphs.

### 7.3.1 Grafici dei risultati / Graphical representation data – Conducted Spurious Emissions

Note: all the traces reported in this section have been obtained with detector Peak, max hold (over last 20 sweeps); RBW: 100kHz, VBW.300kHz

#### Measures executed on WLAN

##### 802.11 Protocol b

Channel Frequency: 2412 MHz, Data Rate: 1Mbps

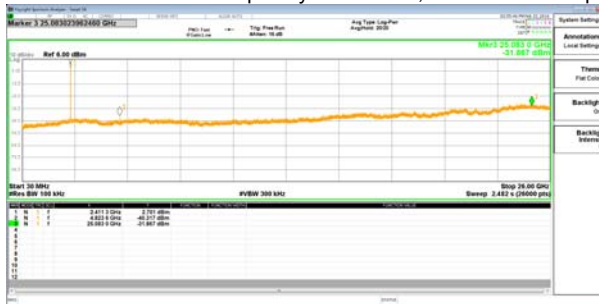

Channel Frequency: 2462 MHz, Data Rate: 1Mbps

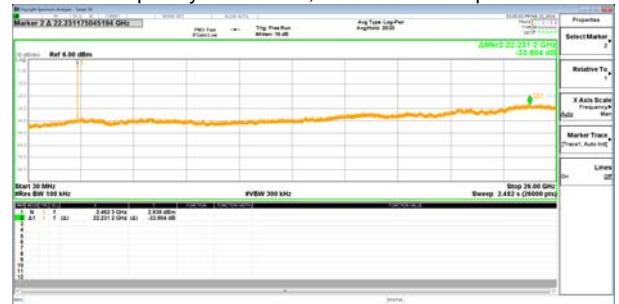

##### 802.11 Protocol g

Channel Frequency: 2412 MHz, Data Rate: 54Mbps

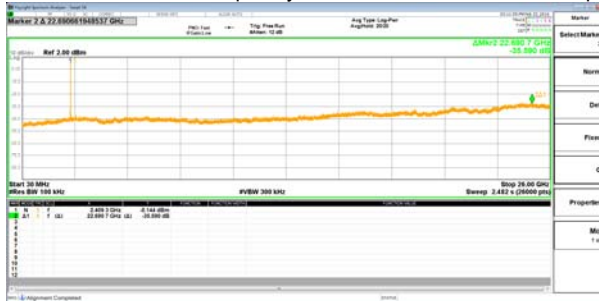

Channel Frequency: 2462 MHz, Data Rate: 24Mbps

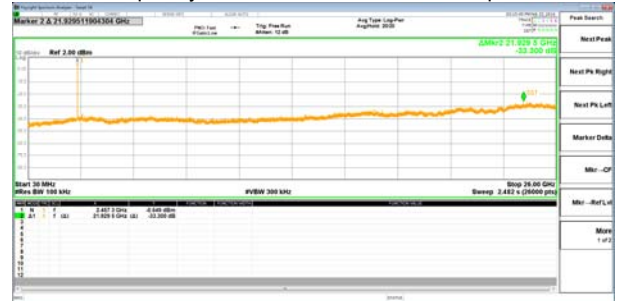

##### 802.11 Protocol n (20MHz)

Channel Frequency: 2412 MHz, Data Rate: 39Mbps

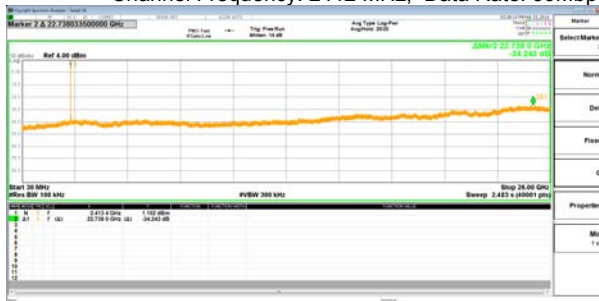

Channel Frequency: 2462 MHz, Data Rate: 65Mbps

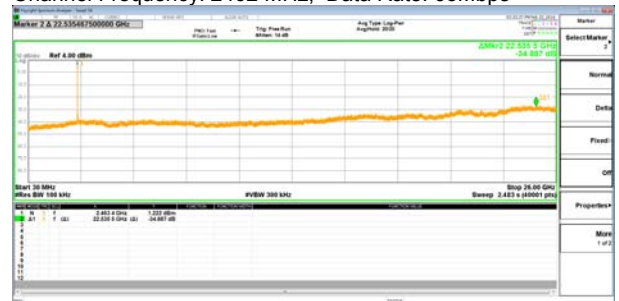

802.11 Protocol n (40MHz)

Channel Frequency: 2422 MHz, Data Rate: 39Mbps

Channel Frequency: 2452 MHz, Data Rate: 6Mbps

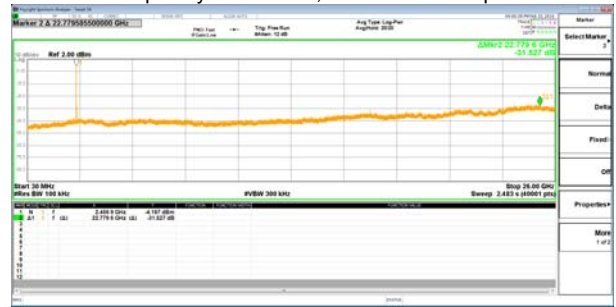
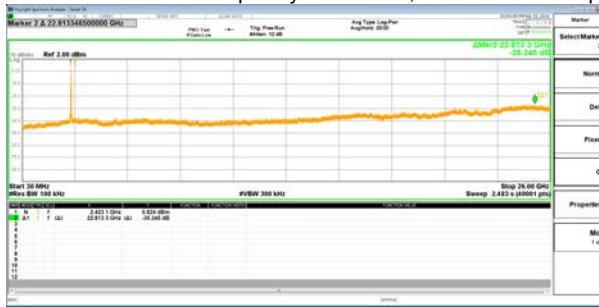

## 8.0 Conducted emission - Condizioni di prova / Test Conditions

Technician / Tecnico: Loris Fruch		
Table No.	TEST:AC Power Line Conducted Emissions, Section 15.207	\
Method	ANSI C63.10: 2009-09, Par. 6.2	\
Parameters required prior to the test	Laboratory Ambient Temperature	18 to 28 °C
	Relative Humidity	20 to 90 %
Parameters recorded during the test	Laboratory Ambient Temperature	21 °C
	Relative Humidity	48 %
Fully configured sample scanned over the following frequency range	150kHz to 30MHz	
Supplementary information:		
<ul style="list-style-type: none"> <li>- EUT Operating Mode: Mode 2 (see par. 2.0);</li> <li>- EUT powered at 24V DC by the AC/DC adapter Type FW7520/24;</li> <li>- Test executed on 110V 60Hz power supply line of the AC/DC adapter Type FW7520/24;</li> <li>- Worst case was detected manipulating the interconnection cables, changing the transmissions channels and modulations and changing the AC power supply voltage between 85 % and 115 %;</li> <li>- During the test Wi-Fi and BT are both active;</li> <li>- Test executed with the following Wi-Fi settings (worst case): protocol "b" on channel 6 at 1Mbps;</li> <li>- Test executed with the following BT settings (worst case): Hopping at 3Mbps (EDR);</li> </ul>		

## 8.1 Apparecchiature utilizzate / Test Equipment Used – Conducted emission

Apparecchiature usate/Equipment Used	Modello/Model	Costruttore/Manufacturer	Numero di serie/Serial Number	Data calibrazione / Calibration date	Intervallo / Interval
EMI Receiver	N9038A	Agilent Technologies	MY51210230	05/2015	1 year
LISN	NSLK 8128	Schwarzbeck	8128-336	09/2015	1 year
Cable RF	MIL C-17 OLWG7	CCI/SAXTON	M17/16.4-00001	10/2015	1 year
Cable RF	S5LL-400	SPIN Electronics	01-053-12	04/2015	1 year
Shielded Chamber	RFD-100	ETS-Lindgren	2012	-	-
Shielded Chamber DC Filter	N5004	ETS-Lindgren	121226	-	-
AC Power Supply	KBT-100-C-109-451	BEHLMAN	5896	12/2015	1 year

### 8.1.1 Apparecchiature ausiliarie / Auxiliary Equipment

Apparecchiature usate / Used Equipment	Modello / Model	Costruttore / Manufacturer	Numero di serie / Serial Number
Access Point	524704	Intellinet	GAP215N16C1800539
CMU Universal Radio Communication Tester	CMU200	Rohde&Schwarz	111416

## 8.2 Fotografie del setup / Photo of the test setup – Conducted emission

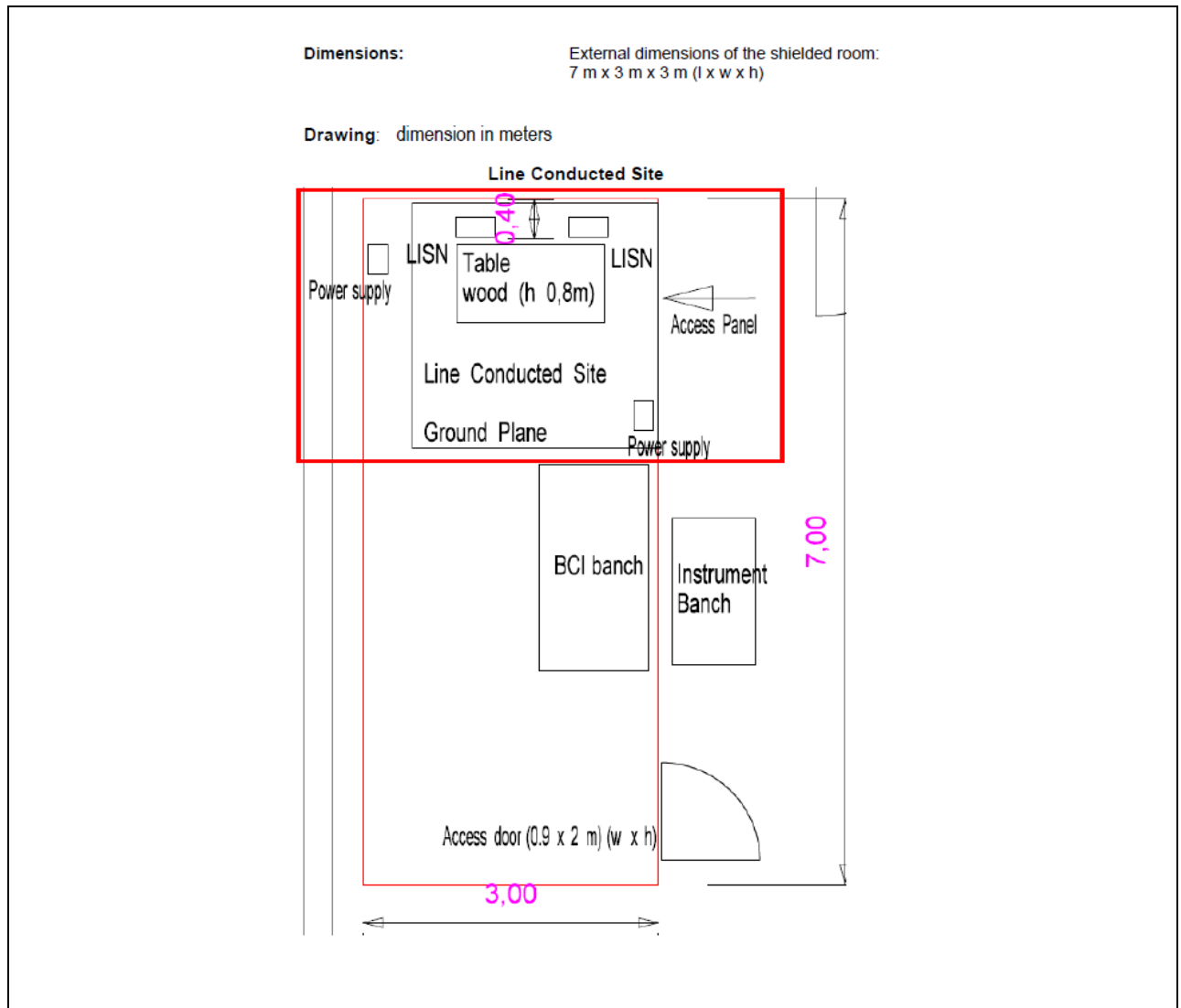

## 8.3 Risultati / Results - Conducted emission

The result of the test is: **PASS**. See the details in the charts of the following paragraphs.



### 8.3.1 Grafici dei risultati / Graphical representation data – Conducted emission

Noise floor measured on 110V 60Hz Line1 (from 0.15MHz to 30MHz): quasi-peak detector (blue trace) and average detector (red trace), with quasi-peak and average limits

Emissions measured in dB $\mu$ V

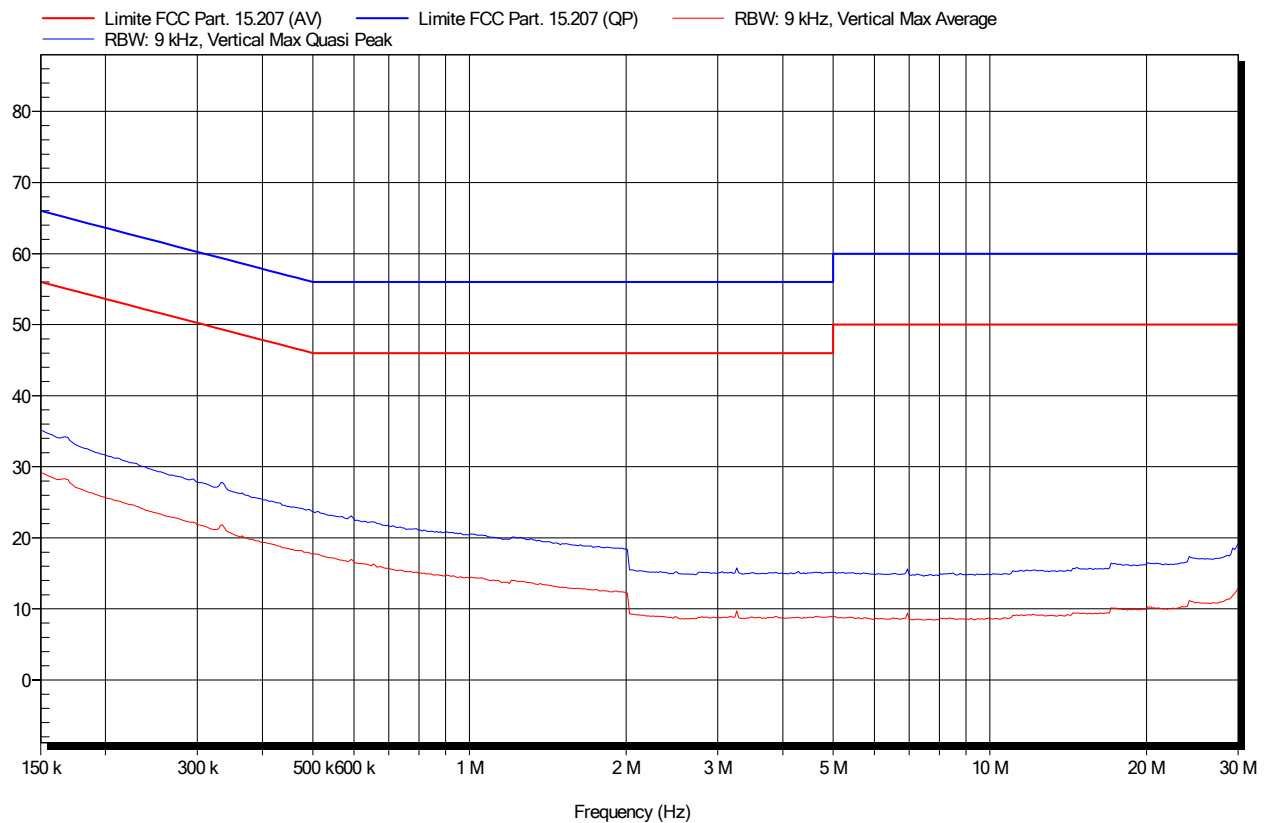



Noise floor measured on 110V 60Hz Line2 (from 0.15MHz to 30MHz): quasi-peak detector (blue trace) and average detector (red trace), with quasi-peak and average limits

Emissions measured in dB $\mu$ V

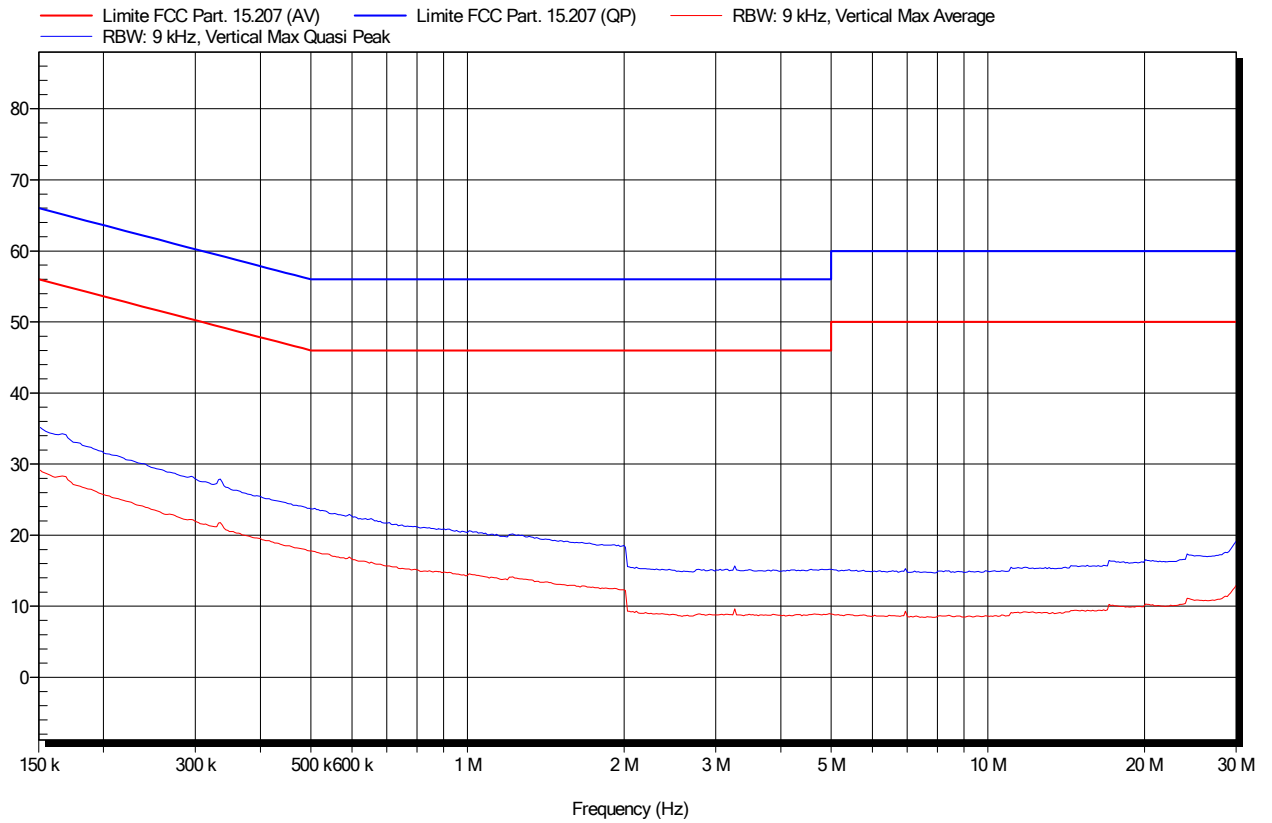

**Measure on EUT**

**(WIFI CH6 at 1Mbps, and BT Hopping) - Worst case detected**

Conducted emission measured on 127V 60Hz Line1 (from 0.15MHz to 30MHz): quasi-peak detector (blue trace) and average detector (red trace), with quasi-peak and average limits  
Emissions measured in dBµV

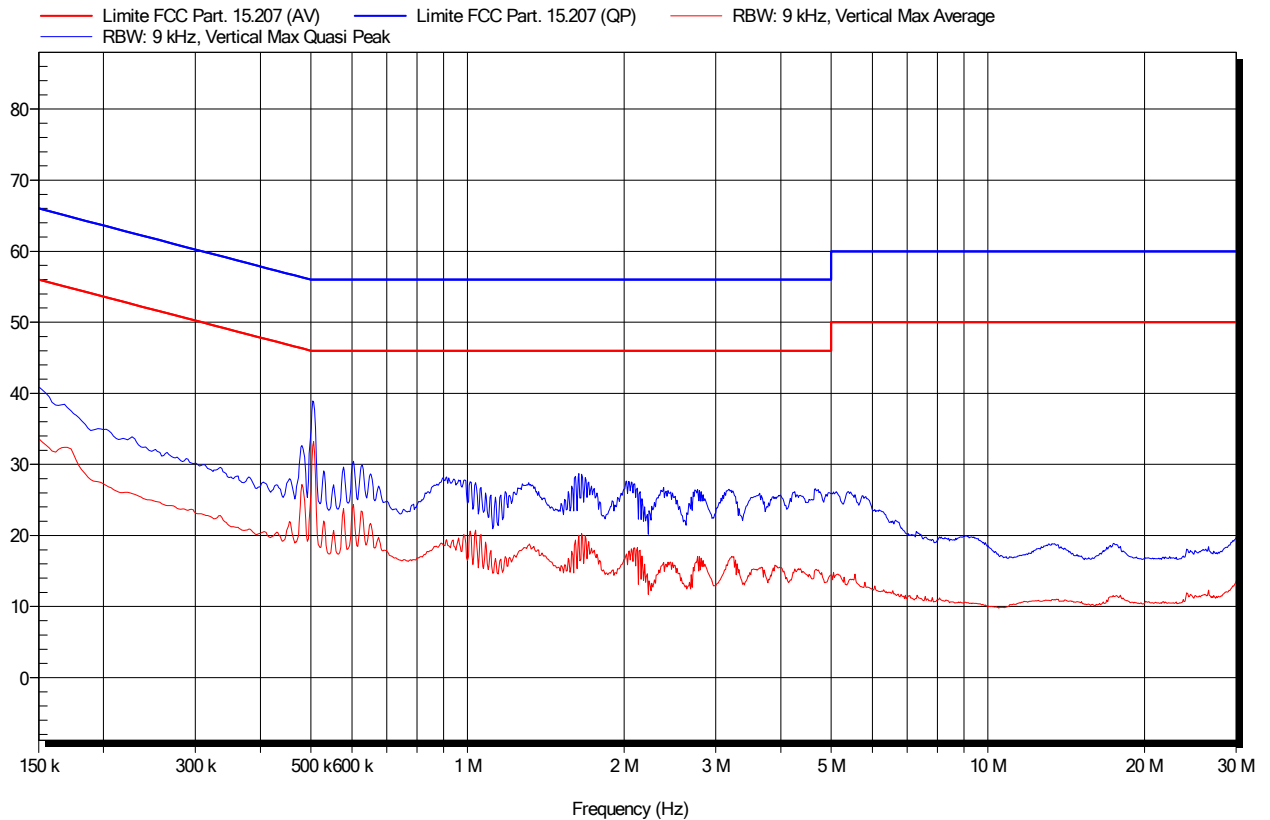

**Signal list**

Frequency (MHz)	Average Measure (dBµV)	Average Limit (dBµV)	Average Difference from limit (dB)	Quasi-peak Measure (dBµV)	Quasi-peak Limit (dBµV)	Quasi-peak Difference from limit (dB)	Result
0.150	33.6	56.0	-22.4	40.9	66.0	-25.2	Pass
0.481	27.2	46.3	-19.1	32.6	56.3	-23.7	Pass
0.506	33.2	46.0	-12.8	38.8	56.0	-17.2	Pass
0.578	23.8	46.0	-22.2	29.6	56.0	-26.4	Pass
0.602	24.4	46.0	-21.6	30.5	56.0	-25.5	Pass
0.627	23.3	46.0	-22.7	29.9	56.0	-26.1	Pass

Conducted emission measured on 127V 60Hz Line2 (from 0.15MHz to 30MHz): quasi-peak detector (blue trace) and average detector (red trace), with quasi-peak and average limits

Emissions measured in dB $\mu$ V

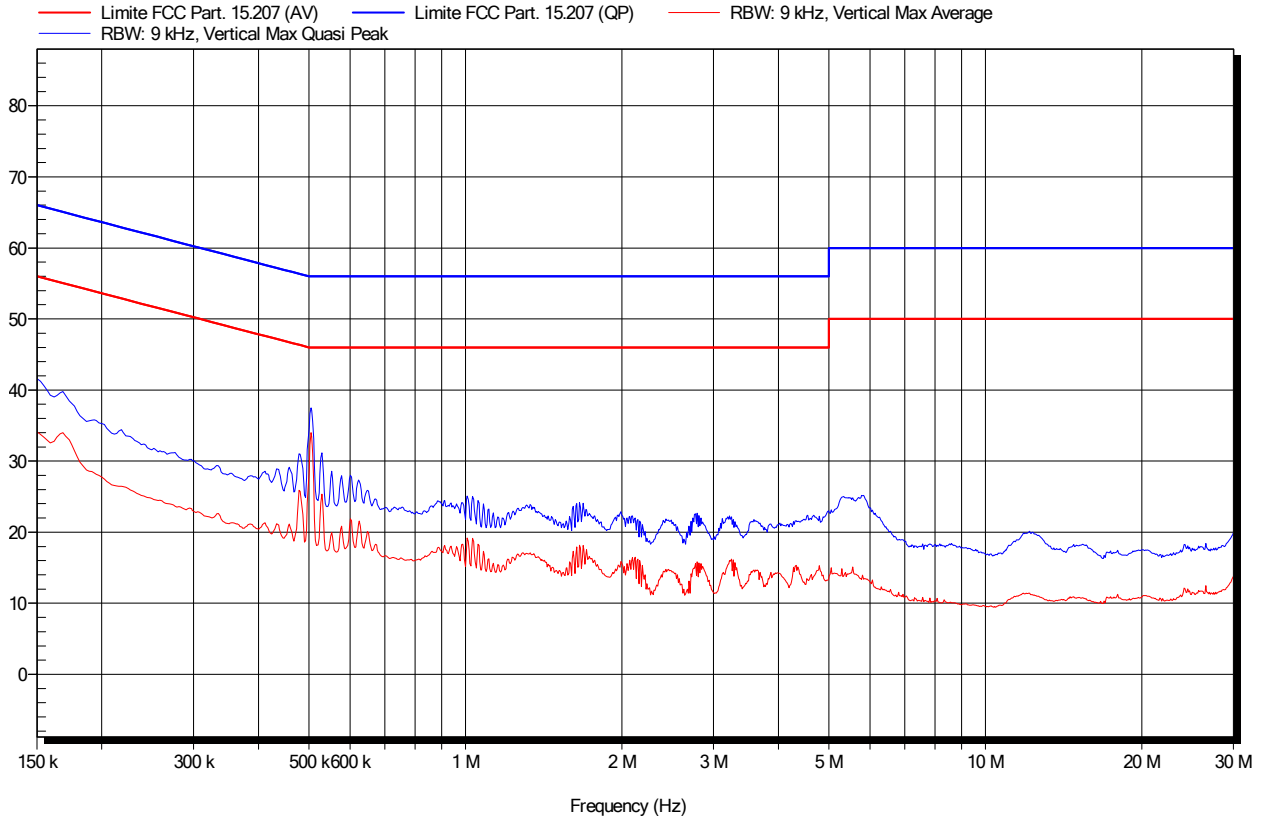

Signal list

Frequency (MHz)	Average Measure (dB $\mu$ V)	Average Limit (dB $\mu$ V)	Average Difference from limit (dB)	Quasi-peak Measure (dB $\mu$ V)	Quasi-peak Limit (dB $\mu$ V)	Quasi-peak Difference from limit (dB)	Result
0.150	34.0	56.0	-22.0	41.5	66.0	-24.5	Pass
0.479	25.9	46.4	-20.5	31.0	56.4	-25.3	Pass
0.503	34.0	46.0	-12.0	37.5	56.0	-18.5	Pass
0.528	25.4	46.0	-20.7	31.2	56.0	-24.9	Pass
0.553	19.9	46.0	-26.1	28.6	56.0	-27.5	Pass
0.600	21.9	46.0	-24.1	28.0	56.0	-28.0	Pass

## 9.0 Spurious Radiated Emissions and Restricted Bands of Operation - Condizioni di prova / Test Conditions

Technician / Tecnico: Loris Fruch		
Table No.	TEST: Spurious Radiated Emissions and Restricted Bands of Operation, Section 15.209 and 15.205	\
Method	ANSI C63.10: 2009-09, Par. 6.3	\
Parameters required prior to the test	Laboratory Ambient Temperature	18 to 28 °C
	Relative Humidity	20 to 90 %
Parameters recorded during the test	Laboratory Ambient Temperature	20-22 °C
	Relative Humidity	44-55 %
Supplementary information:		
<ul style="list-style-type: none"> <li>- Frequency range of the measurements: up to 25GHz</li> <li>- Test site: SAC for measures from 30MHz to 1GHz and FAR (Semi-anechoic chamber with additional absorbers on the floor) for measures from 1GHz to 25GHz;</li> <li>- EUT powered at 24Vdc;</li> <li>- EUT Operating Mode: Mode 2 for measures up to 1GHz, Mode 2, Mode 3 and Mode 4 for measures &gt;1GHz (see par. 2.0);</li> <li>- The EUT was placed on turn-platform on a dielectric support of 0.8m height (above the ground plane) for measures up to 1GHz and on a dielectric support of 1.5m height for measures from 1GHz to 25GHz.</li> <li>- The EUT was placed 3m apart from the receiving antenna;</li> <li>- The measures were executed rotating the EUT on three orthogonal axis as specified at par. 6.6.4 and 6.6.4.2 of ANSI C63.10: 2009-09 (pointing antenna towards the source of emission not required);</li> <li>- The turn-platform is rotated from 0° to 360° degrees to determine the position of maximum emission level. The antenna height was changed from 1m to 4m for measures in the band 30MHz to 1GHz and from 1m to 2.5m for measures in the band 1GHz to 25GHz, to find the highest emission;</li> <li>- The receiving antenna was positioned in horizontal and vertical polarization (by means of an automatic procedure computer assisted).</li> <li>- For Radiated spurious emissions, preliminary scans were performed for all data rates and orientations X, Y and Z of EUT + Tx Antenna and only worst-case results (final measurements) are reported in this report.</li> <li>- The measurements were made with the detector set to PEAK within a IF bandwidth of 200Hz from 9KHz to 150KHz, of 120KHz from 30MHz to 1GHz and of 1000KHz from 1GHz to 25GHz; The final measurements with Quasi-Peak/AVE detector were performed at least for frequencies for which the Peak values was <math>\geq</math> (limit – 4dB);</li> <li>- Antennas used during measurements: Loop antenna from 9KHz to 30MHz, Bilog antenna from 30MHz to 1GHz and Horn antenna from 1GHz to 25GHz; Note: the exploratory measure in the frequency band 12GHz to 18GHz and 18GHz to 25GHz were performed using the standard Horn antennas AMTP-62-20_C-SF and AMTP-42-20_C-SF but the final measurements were performed using the Horn ETS 3117 antenna;</li> <li>- High Pass Filters used during measurements (connected between receiving antenna and Pre-Amplifier): model VHP-39 for measures from 4GHz to 12GHz model VHF-7150+ for measures from 12GHz to 18GHz</li> <li>- It was checked that radiated emissions in the restricted bands (2483.5-2500MHz) comply with the radiated emission limits specified in §15.209(a) (=54dBuV/m) as well.</li> <li>- It was checked that the band edge in the restricted bands complies with the radiated emission limits specified in §15.209(a) (=54dBuV/m). At par. 9.3.1.1 worst case results are reported (nearest restricted band 2483.5-2500MHz);</li> <li>- Spurious radiated emissions test was executed with the following radio settings (worst case): <ul style="list-style-type: none"> <li>• Wi-Fi protocol “b” on channel 6 at 1Mbps + BT Hopping;</li> <li>• Wi-Fi protocol “b” on channel 6 at 1Mbps;</li> <li>• BT CW mode (without modulation) on channel 38;</li> </ul> </li> <li>- GSM link between EUT and CMU200 base station was set on GSM900 band during measures &gt;1GHz and on GSM1800 band during measures &lt;1GHz;</li> </ul>		

## 9.1 Apparecchiature utilizzate / Test Equipment Used – Spurious Radiated Emissions and Restricted Bands of Operation

<i>Apparecchiature usate/Equipment Used</i>	<i>Modello/Model</i>	<i>Costruttore/Manufacturer</i>	<i>Numero di serie/Serial Number</i>	<i>Data calibrazione / Calibration date</i>	<i>Intervallo / Interval</i>
EMI Receiver MXE	N9038A	Agilent Technologies	MY51210230	05/2015	1 year
Loop Antenna	6502	ETS-Lindgren	00164807	05/2015	1 year
Bilog Antenna	Bilog CBL6111C	Chase	2415	10/2015	1 year
Horn Antenna Double-Ridged Waveguides	3117	ETS-Lindgren	00201258	08/2015	1 year
High Pass Filter	VHP-39	Mini-Circuits	31520	09/2015	1 year
High Pass Filter	VHF-7150+	Mini-Circuits	31510	09/2015	1 year
Pre-Amplifier	SPIN WBPR_01-21-20	SPIN Electronics	01-100-09	06/2015	1 year
Pre-Amplifier	HP8447F, OPT H64	Hewlett/Packard	3113A07568	08/2015	1 year
RF Cable	S5LL-400	Spin electronics	01-053-12	04/2015	1 year
RF Cable	S5LL-900	Spin electronics	02-053-12	04/2015	1 year
RF Cable	41.275.000-L03	CPE Italia Spa	F4538	02/2015	1 year
RF Cable	41.275.000-L04	CPE Italia Spa	F4539	02/2015	1 year
RF Cable	SKBL-2M-LOW	Minicircuits	1101189	09/2015	1 year
Standard Gain Horn Antenna	AMTP-62-20_C-SF	SPIN Electronics	01-165-12	-	-
Standard Gain Horn Antenna	AMTP-42-20_C-SF	SPIN Electronics	01-165-12	-	-
Multi-Device Controller	2090	ETS-Lindgren	81311	-	-
Antenna Mast	2175	ETS-Lindgren	136028	-	-
SAC3 – DC Filter	N6006	ETS-Lindgren	202031	-	-
Semi-Anechoic Chamber	-	ETS-Lindgren	5207	-	-
DC Power Supply	E3634A	Agilent	MY51070025	-	-

### 9.1.1 Apparecchiature ausiliarie / Auxiliary Equipment

<i>Apparecchiature usate / Used Equipment</i>	<i>Modello / Model</i>	<i>Costruttore / Manufacturer</i>	<i>Numero di serie / Serial Number</i>
Access Point	524704	Intellinet	GAP215N16C1800539
CMU Universal Radio Communication Tester	CMU200	Rohde&Schwarz	111416

**9.2 Fotografie del setup / Photo of the test setup –Spurious Radiated Emissions and Restricted Bands of Operation**

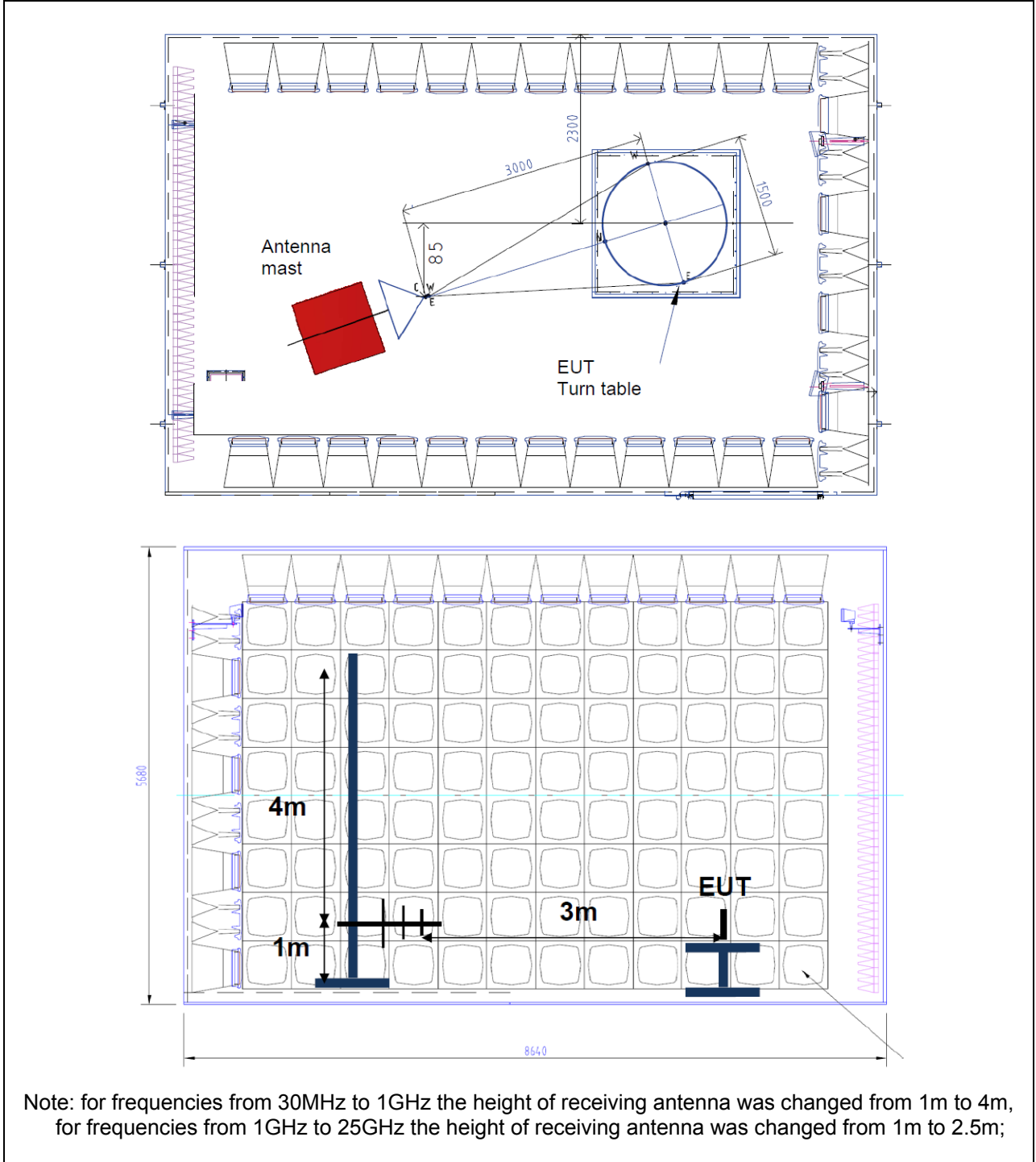

### 9.3 Risultati / Results - Spurious Radiated Emissions and Restricted Bands of Operation

The result of the test is: **PASS**. See the details in the charts/tables of the following paragraphs.

Level of maximum spurious detected:

WIFI harmonic

Frequency [MHz]	Average [dB $\mu$ V/m]	Average Limit [dB $\mu$ V/m]	Difference from Limit [dB $\mu$ V/m]	EUT Angle [°]	Antenna Height [mt]	Result
4874.000	41.5	54.0	-12.6	360	1.70	Pass

Non harmonic signal

Frequency [MHz]	Average [dB $\mu$ V/m]	Average Limit [dB $\mu$ V/m]	Difference from Limit [dB $\mu$ V/m]	EUT Angle [°]	Antenna Height [mt]	Result
1883.000	48.2	54.0	-5.8	13	2.00	Pass

#### 9.3.1 Tabelle e grafici dei risultati / Tables and graphical representation data – Spurious Radiated Emissions and Restricted Bands of Operation

### 9.3.1.1 Restricted Bands of Operation

#### (WIFI CH11 at 65Mbps) - Worst case detected

Radiated emissions measured from 2.31GHz to 2.5GHz. Peak detector (green trace), average detector (brown line) with IF=1MHz. Average limit (blue line). Vertical polarization and EUT on Y Axis.

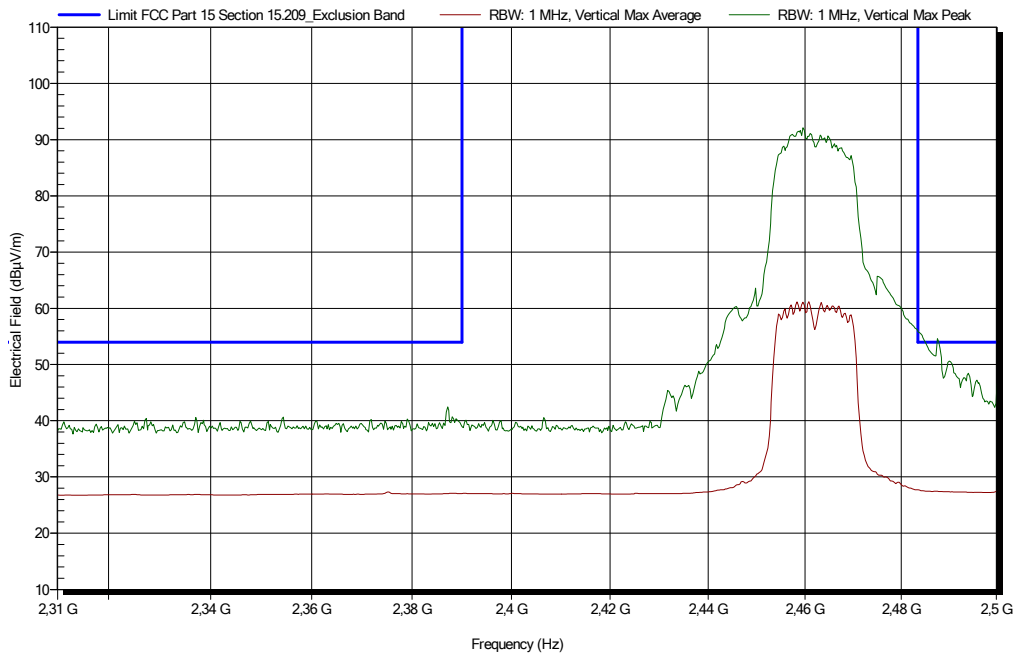

#### (Bluetooth Low Energy CH78 at 1Mbps BR) - Worst case detected

Radiated emissions measured from 2.31GHz to 2.5GHz. Peak detector (green trace), average detector (brown line) with IF=1MHz. Average limit (blue line). Vertical polarization and EUT on Y Axis.

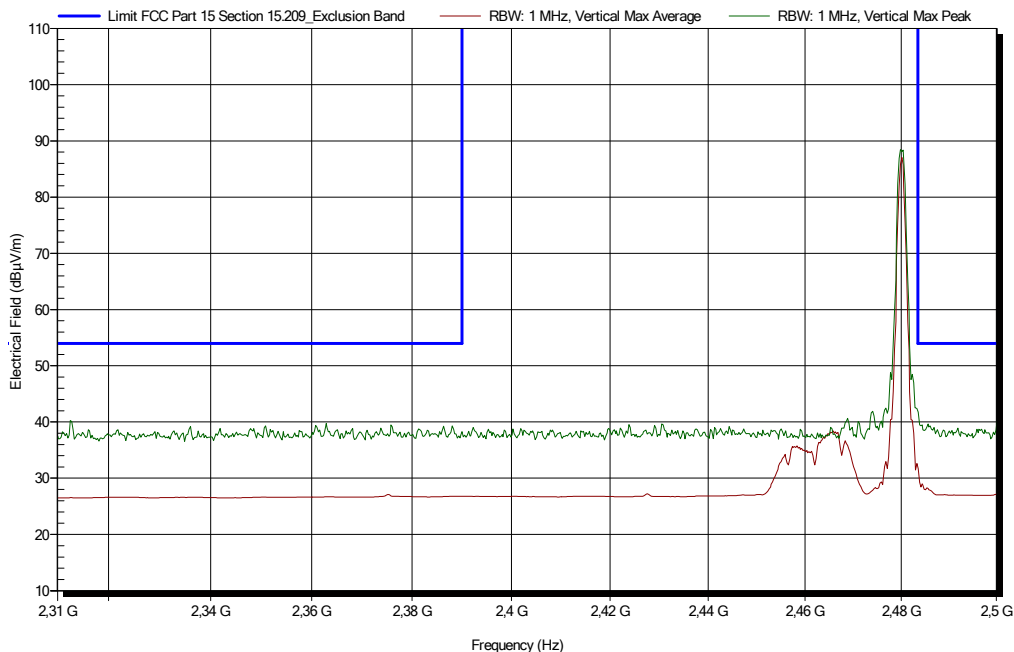



**(Bluetooth CH78 at 3Mbps EDR3) - Worst case detected**

Radiated emissions measured from 2.31GHz to 2.5GHz. Peak detector (green trace), average detector (brown line) with IF=1MHz. Average limit (blue line). Vertical polarization and EUT on Y Axis.

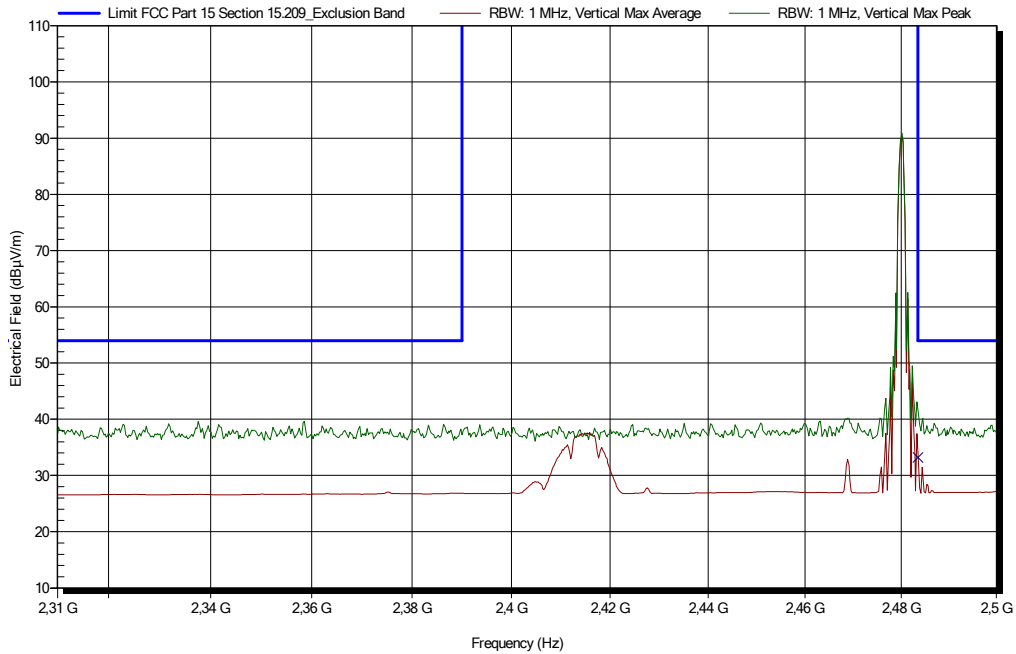

Marker list

Frequency [MHz]	Average [dBµV/m]	Average Limit [dBµV/m]	Difference from Limit [dBµV/m]	EUT Angle [°]	Antenna Height [mt]	Result
2484.000	33.2	54.0	-20.8	0	1.50	Pass

**(WIFI CH11 at 65Mbps and Bluetooth Hopping) - Worst case detected**

Radiated emissions measured from 2.31GHz to 2.5GHz. Peak detector (green trace), average detector (brown line) with IF=1MHz. Average limit (blue line). Vertical polarization and EUT on Y Axis.

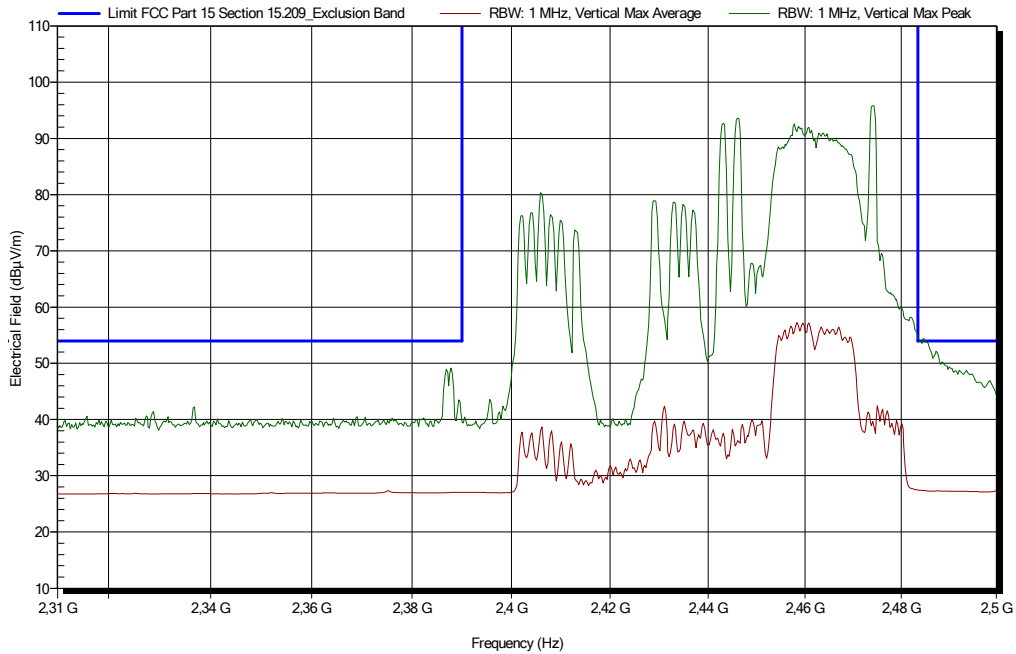

### 9.3.1.2 Spurious Radiated Emissions

#### Measures from 9KHz to 30MHz

Noise floor measured from 9KHz to 30MHz. Peak detector (green trace) with IF=200Hz from 9KHz to 150KHz and IF=9KHz from 150KHz to 30MHz. Q-Peak/Average limit (blue line). Vertical polarisation.

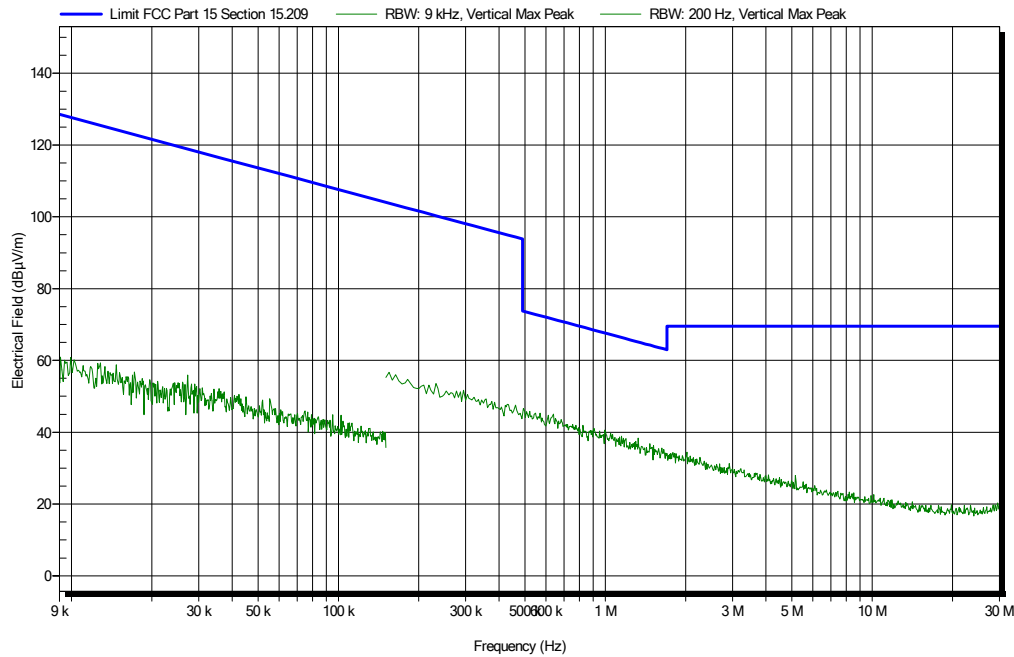

Noise floor measured from 9KHz to 30MHz. Peak detector(green trace) with IF=200Hz from 9KHz to 150KHz and IF=9KHz from 150KHz to 30MHz. Q-Peak/Average limit (blue line). Horizontal polarisation.

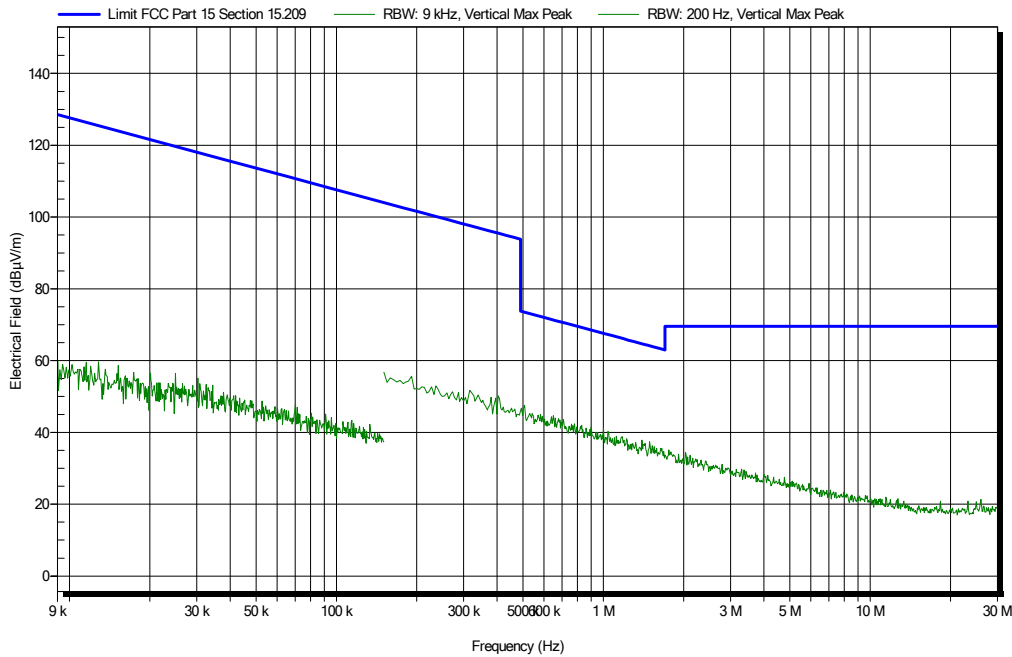

### Measure on EUT

No emissions detected above noise level.

### Measures from 30MHz to 1GHz

Noise floor measured from 30MHz to 1GHz. Peak detector (green trace)with IF=120KHz. Q-Peak limit (blue line). Vertical polarization.

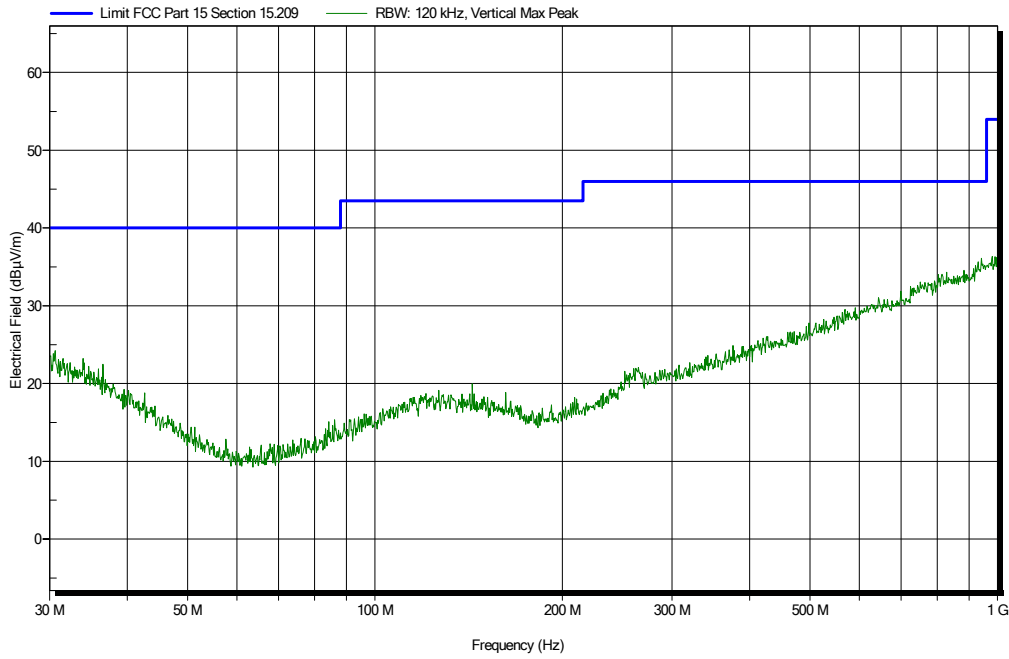

Noise floor measured from 30MHz to 1GHz. Peak detector (green trace)with IF=120KHz. Q-Peak limit (blue line). Horizontal polarization.

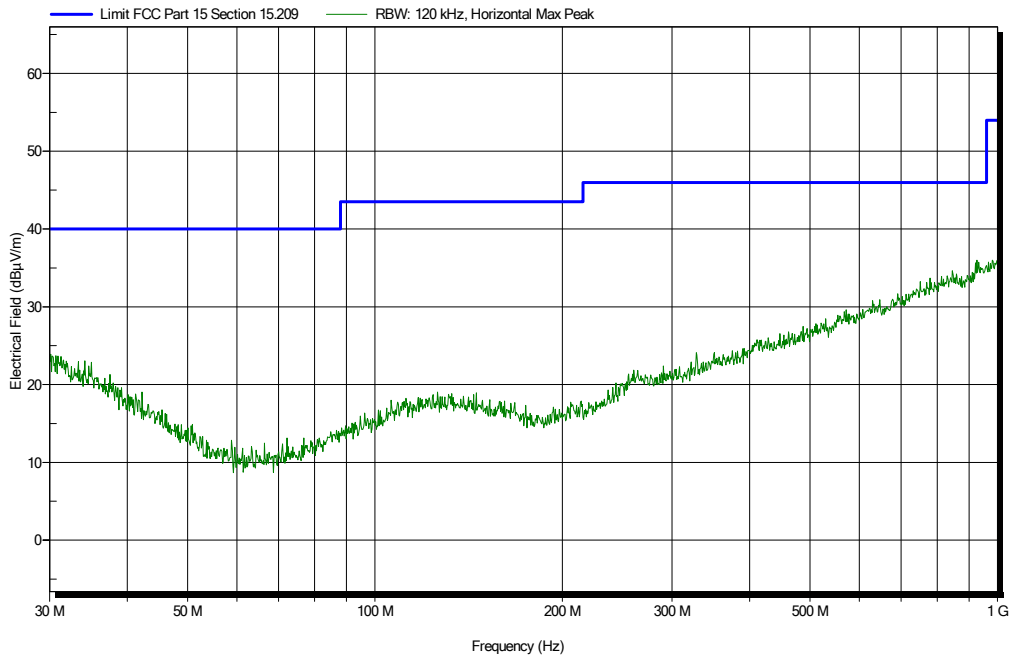

**Measure on EUT**

**(WIFI CH6 at 1Mbps and Bluetooth Hopping) - Worst case detected**

Radiated emissions measured from 30MHz to 1GHz. Peak detector (green trace) with IF=120KHz.

Q-Peak limit (blue line). Vertical polarization and EUT on Z Axis.

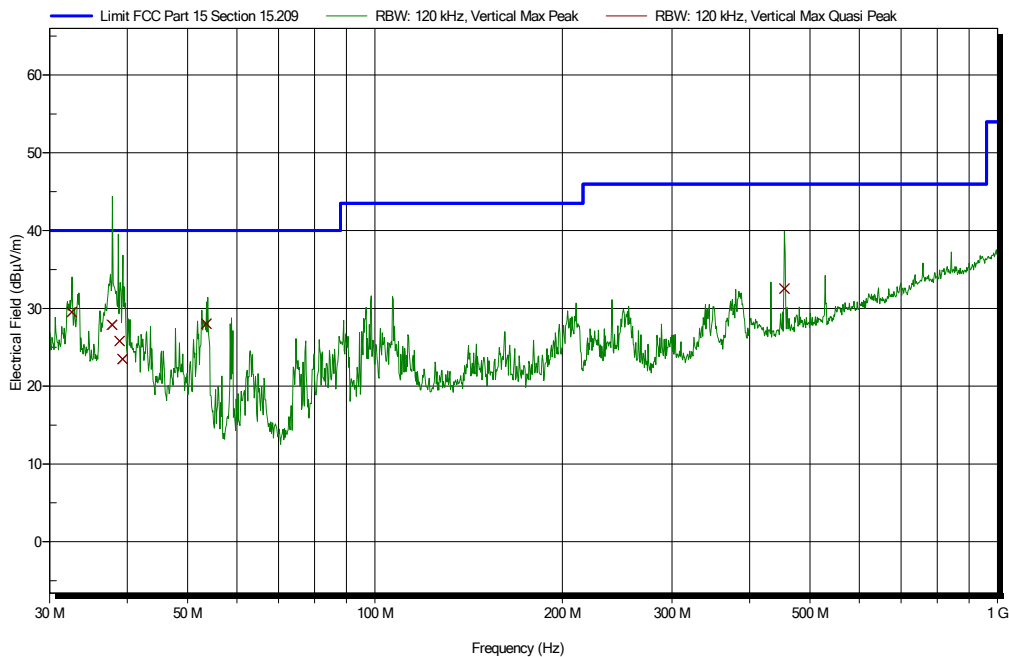

Higher signals, maximized and re-measured with quasi-peak detector

Frequency [MHz]	Quasi-Peak [dBµV/m]	Quasi-Peak Limit [dBµV/m]	Difference from Limit [dBµV/m]	EUT Angle [°]	Antenna Height [mt]	Result
39.300	23.5	40.0	-16.5	340	2.00	Pass
37.800	27.9	40.0	-12.1	153	1.20	Pass
38.880	25.8	40.0	-14.2	150	2.06	Pass
32.580	29.5	40.0	-10.5	200	1.30	Pass
53.580	28.0	40.0	-12.0	207	1.00	Pass
454.620	32.6	46.0	-13.4	222	1.84	Pass

Radiated emissions measured from 30MHz to 1GHz. Peak detector (green trace) with IF=120KHz. Q-Peak limit (blue line). Horizontal polarization and EUT on X Axis.

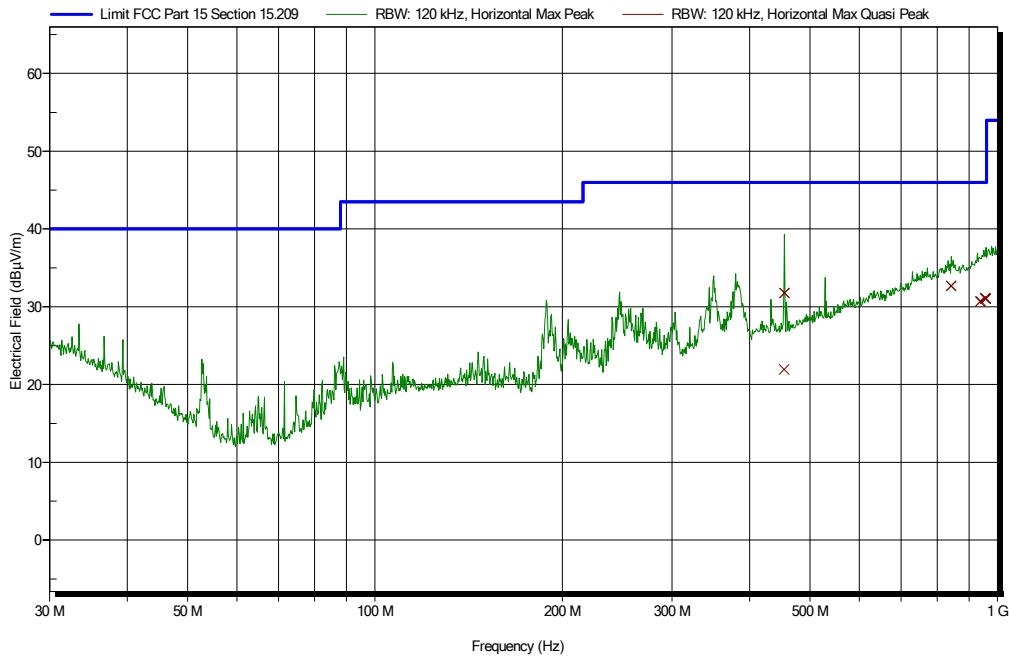

Higher signals, maximized and re-measured with quasi-peak detector

Frequency [MHz]	Quasi-Peak [dBµV/m]	Quasi-Peak Limit [dBµV/m]	Difference from Limit [dBµV/m]	EUT Angle [°]	Antenna Height [mt]	Result
955.620	31.1	46.0	-14.9	27	1.57	Pass
454.680	31.8	46.0	-14.2	242	2.06	Pass
937.860	30.7	46.0	-15.3	27	4.00	Pass
842.100	32.7	46.0	-13.3	135	1.00	Pass
956.340	31.0	46.0	-15.0	135	2.61	Pass
454.380	21.9	46.0	-24.1	292	2.37	Pass

### Measures from 1GHz to 4GHz

Noise floor measured from 1GHz to 4GHz. Peak detector (green trace) with IF=1MHz. Average limit (blue line). Vertical polarization.

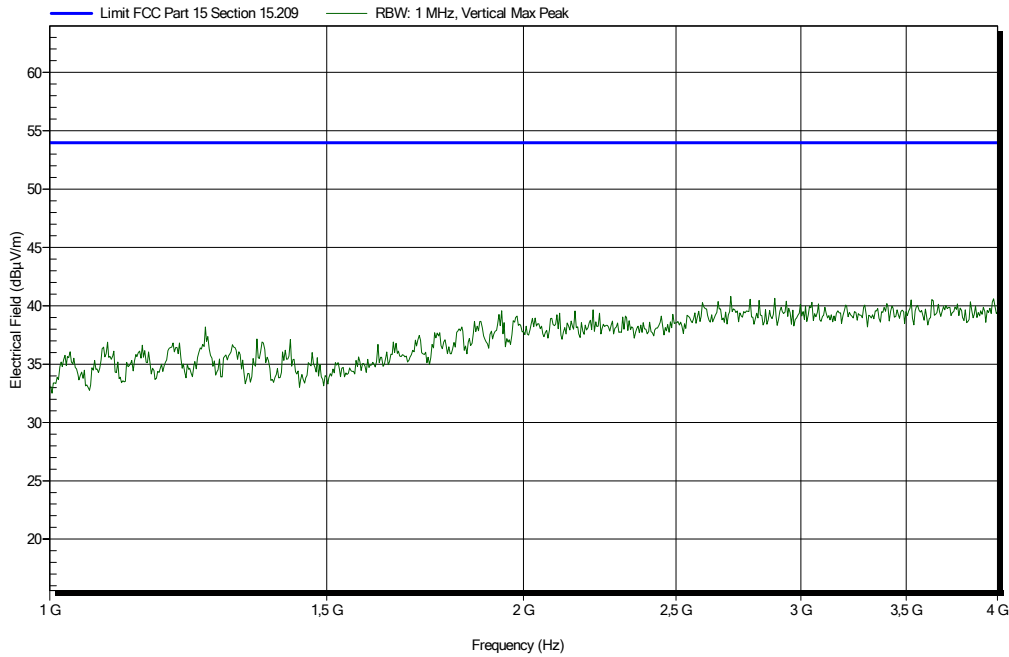

Noise floor measured from 1GHz to 4GHz. Peak detector (green trace) with IF=1MHz. Average limit (blue line). Horizontal polarization.

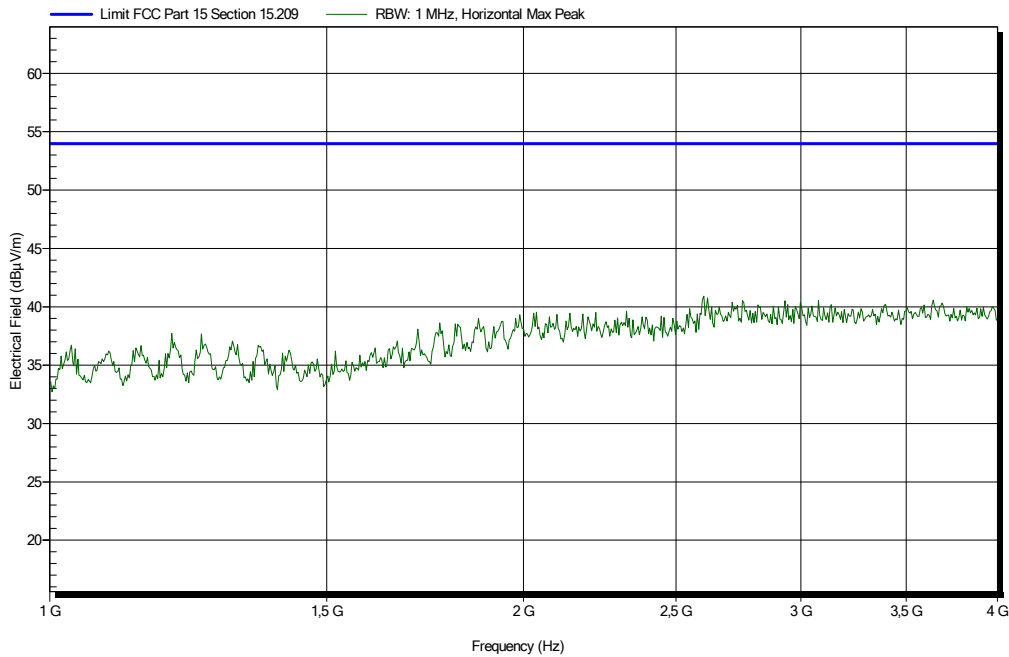



**Measure on EUT**

**(WIFI CH6 at 1Mps) - Worst case detected**

Radiated emissions measured from 1GHz to 4GHz: peak detector (green trace) with Average limit (blue line). Vertical polarization and EUT on Y Axis.

Note: in the next chart the signals on marker Nr 6 is inside of the WLAN exclusion band (2.437GHz)

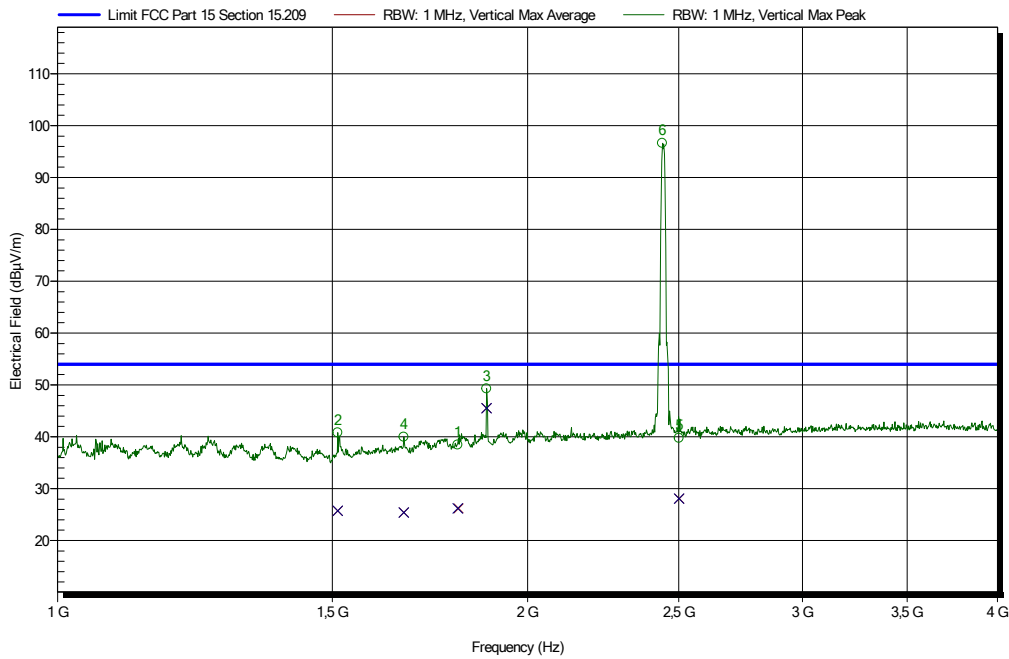

Higher signals, maximized and re-measured with average detector

Frequency [MHz]	Average [dBµV/m]	Average Limit [dBµV/m]	Difference from Limit [dBµV/m]	EUT Angle [°]	Antenna Height [mt]	Result
1805,000	26,2	54,0	-27,8	55	1,65	Pass
1512,000	25,7	54,0	-28,3	70	1,35	Pass
1883,000	45,5	54,0	-8,5	203	2,50	Pass
1667,000	25,4	54,0	-28,6	248	1,50	Pass
2501,000	28,1	54,0	-25,9	10	1,00	Pass

Radiated emissions measured from 1GHz to 4GHz: peak detector (green trace) with Average limit (blue line). Horizontal polarization and EUT on Z Axis.

Note: in the next graphic the signals on marker Nr 5 is inside of the WLAN exclusion band (2.437GHz)

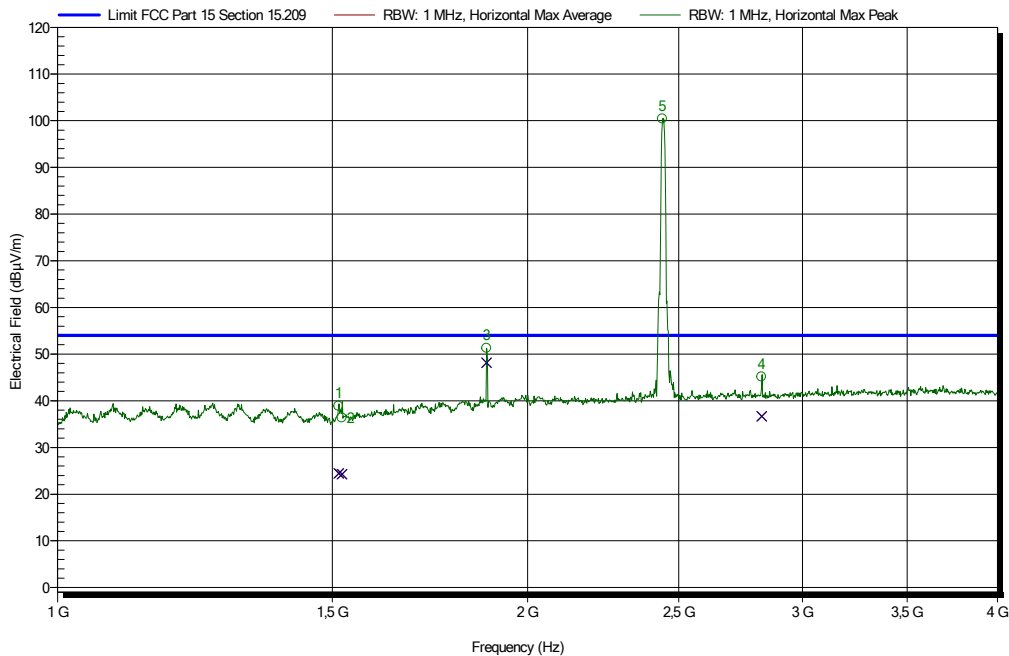

Higher signals, maximized and re-measured with average detector

Frequency [MHz]	Average [dBµV/m]	Average Limit [dBµV/m]	Difference from Limit [dBµV/m]	EUT Angle [°]	Antenna Height [mt]	Result
1514,000	24,4	54,0	-29,6	28	1,00	Pass
1521,000	24,3	54,0	-29,7	248	2,50	Pass
1883,000	48,2	54,0	-5,8	13	2,00	Pass
2824,000	36,7	54,0	-17,3	60	1,00	Pass

**(Bluetooth CH38 CW) - Worst case detected**

Radiated emissions measured from 1GHz to 4GHz: peak detector (green trace) with Average limit (blue line). Vertical polarization and EUT on X Axis.

Note: in the next graphic the signals on marker Nr5 is inside the Bluetooth exclusion band (2.440GHz)

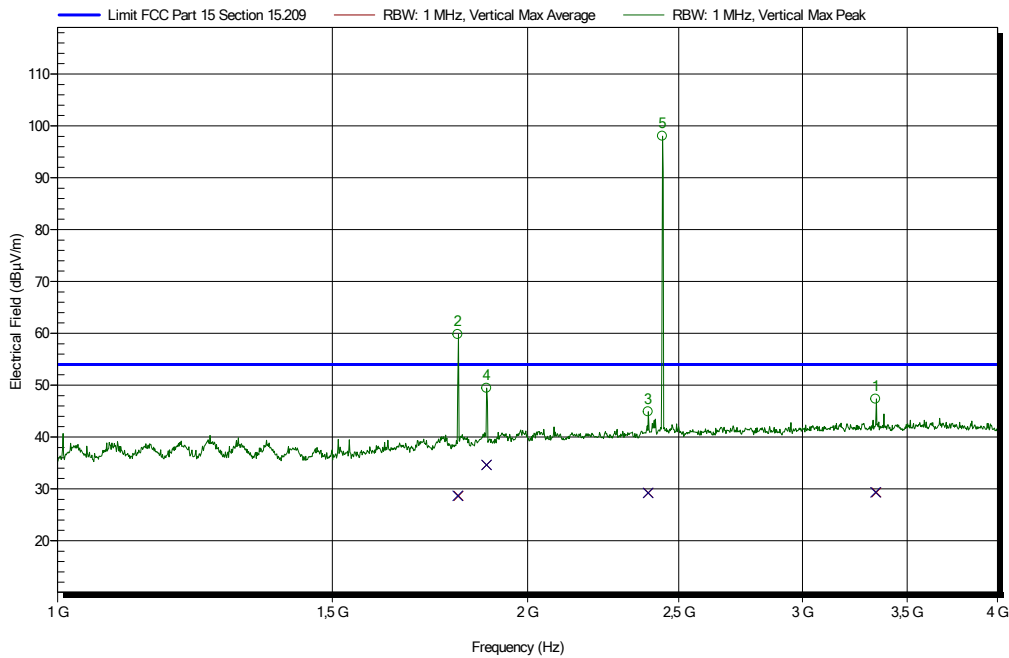

Higher signals, maximized and re-measured with average detector

Frequency [MHz]	Average [dBµV/m]	Average Limit [dBµV/m]	Difference from Limit [dBµV/m]	EUT Angle [°]	Antenna Height [mt]	Result
3342,000	29,3	54,0	-24,7	83	2,40	Pass
1805,000	28,7	54,0	-25,3	168	2,25	Pass
2389,000	29,2	54,0	-24,8	213	1,10	Pass
1883,000	34,6	54,0	-19,4	85	2,50	Pass

Radiated emissions measured from 1GHz to 4GHz: peak detector (green trace) with Average limit (blue line). Horizontal polarization and EUT on Z Axis.

Note: in the next graphic the signals on marker Nr5is inside of the WLAN exclusion band (2.437GHz)

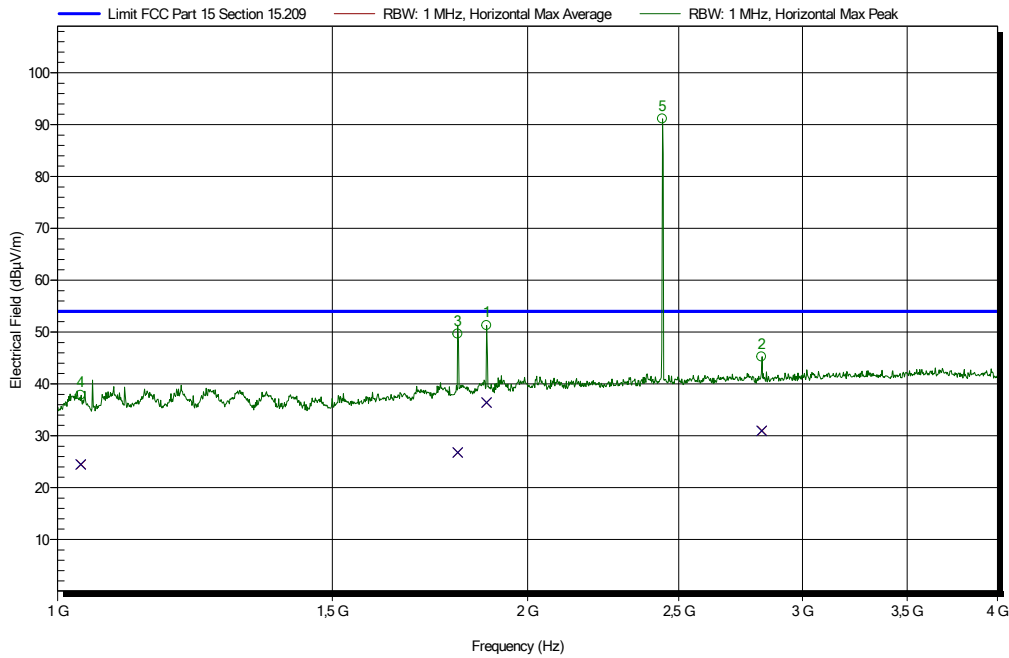

Higher signals, maximized and re-measured with average detector

Frequency [MHz]	Average [dBµV/m]	Average Limit [dBµV/m]	Difference from Limit [dBµV/m]	EUT Angle [°]	Antenna Height [mt]	Result
1883.000	36.4	54.0	-17.6	43	2.30	Pass
2824.000	31.0	54.0	-23.0	228	1.00	Pass
1805.000	26.8	54.0	-27.2	253	2.25	Pass
1035.000	24.5	54.0	-29.5	208	2.40	Pass

**(WIFI CH6 at 1Mbps and Bluetooth Hopping) - Worst case detected**

Radiated emissions measured from 1GHz to 4GHz: peak detector (green trace) with Average limit (blue line). Vertical polarization and EUT on Z Axis.

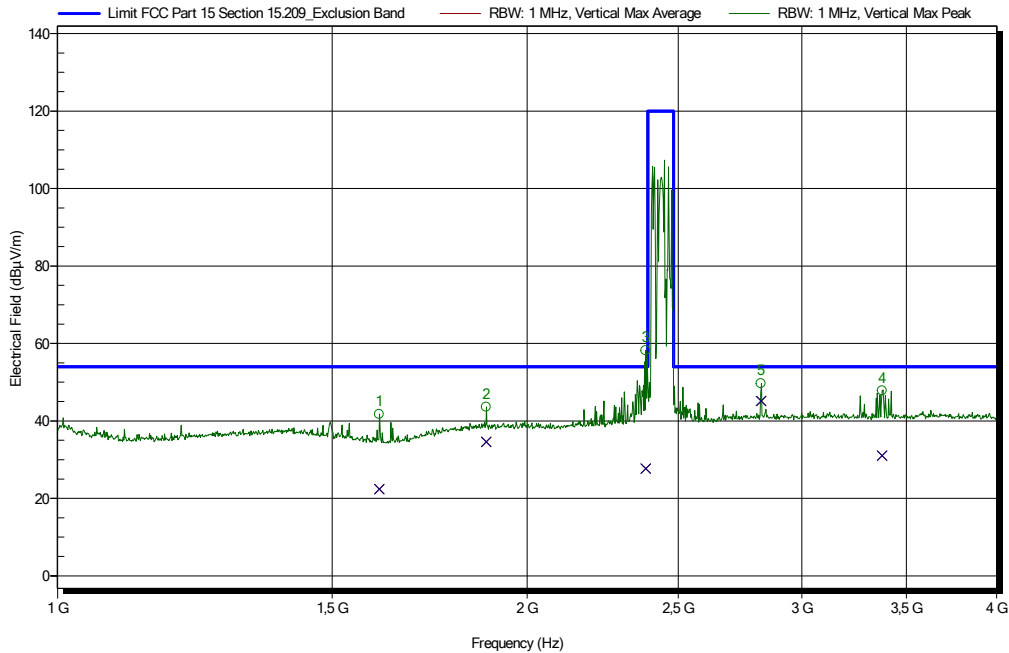

Higher signals, maximized and re-measured with average detector

Frequency [MHz]	Average [dB $\mu$ V/m]	Average Limit [dB $\mu$ V/m]	Difference from Limit [dB $\mu$ V/m]	EUT Angle [°]	Antenna Height [mt]	Result
1608.000	22.4	54.0	-31.6	158	1.63	Pass
1883.000	34.6	54.0	-19.4	158	1.63	Pass
2383.000	27.7	54.0	-26.3	90	1.50	Pass
2824.000	45.2	54.0	-8.8	315	1.50	Pass
3377.000	31.1	54.0	-22.9	68	1.50	Pass

Radiated emissions measured from 2.2GHz to 2.6GHz and from 3.26GHz to 3.43GHz: average detector (brown trace) with Average limit (blue line). Vertical polarization and EUT on Z Axis.

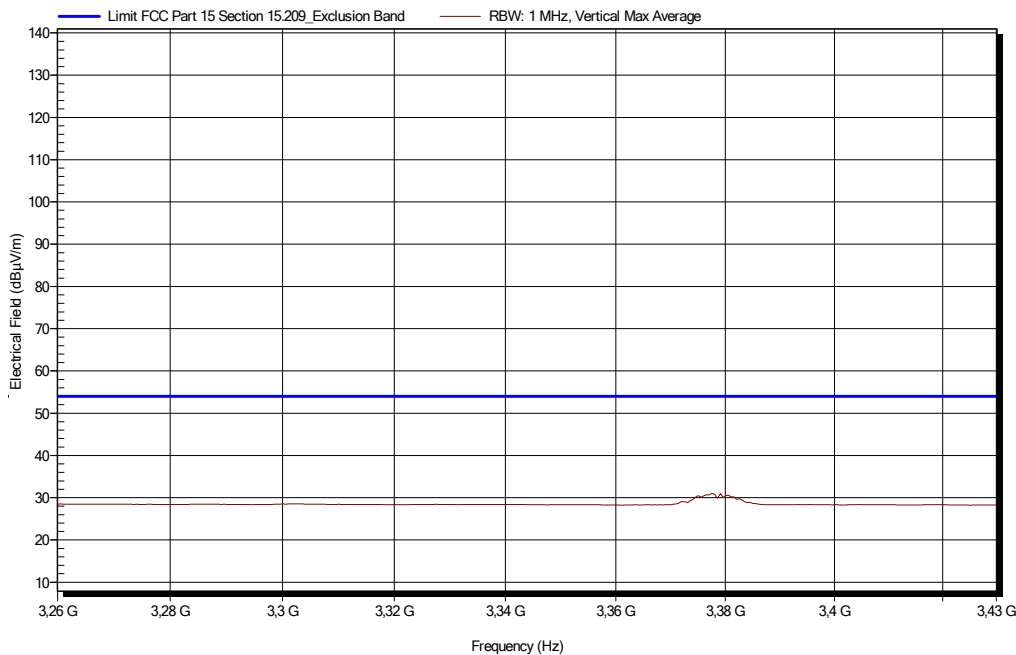
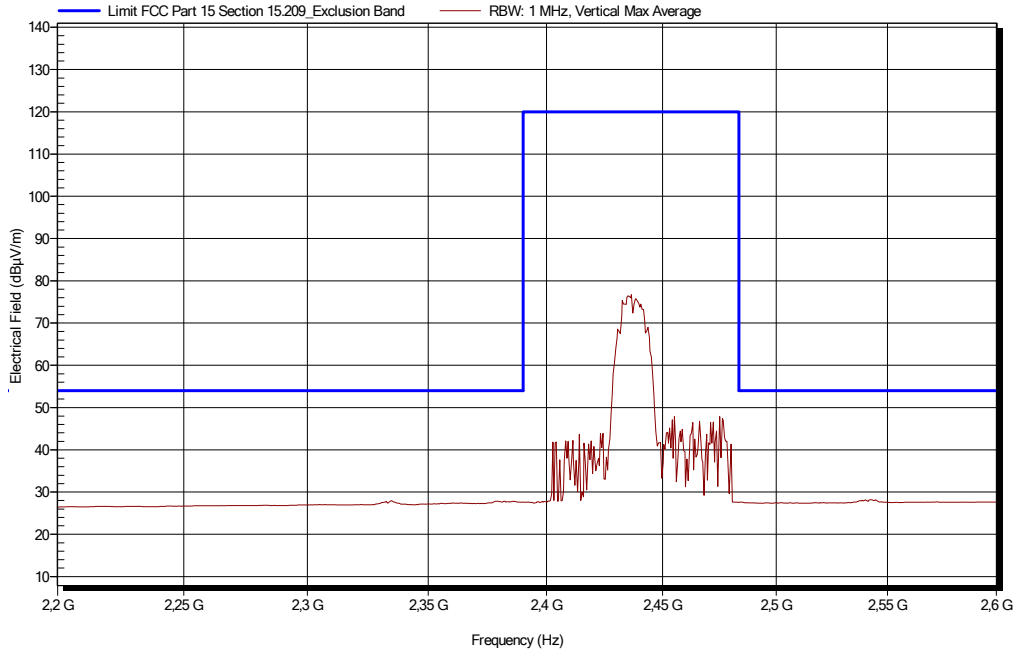

Radiated emissions measured from 1GHz to 4GHz: peak detector (green trace) with Average limit (blue line). Horizontal polarization and EUT on Y Axis.

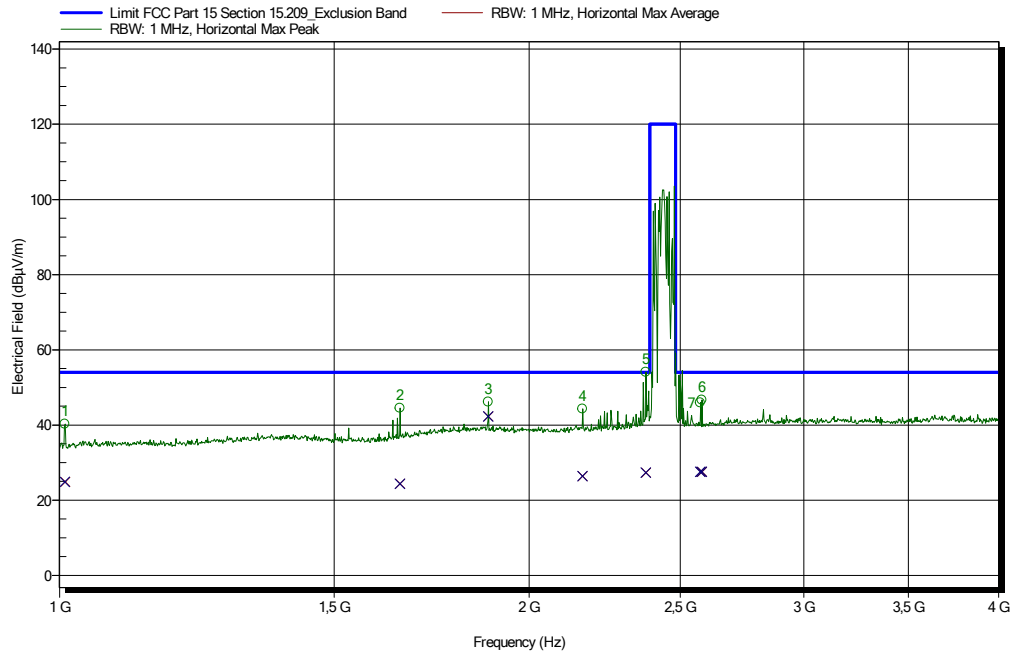

Higher signals, maximized and re-measured with average detector

Frequency [MHz]	Average [dBµV/m]	Average Limit [dBµV/m]	Difference from Limit [dBµV/m]	EUT Angle [°]	Antenna Height [mt]	Result
1008.000	24.9	54.0	-29.1	135	1.10	Pass
1653.000	24.4	54.0	-29.6	90	2.00	Pass
1883.000	42.3	54.0	-11.7	23	1.50	Pass
2164.000	26.4	54.0	-27.6	158	1.63	Pass
2377.000	27.4	54.0	-26.6	23	2.25	Pass
2581.000	27.5	54.0	-26.5	90	1.50	Pass
2575.000	27.5	54.0	-26.5	90	1.50	Pass

Radiated emissions measured from 2.2GHz to 2.55GHz: average detector (brown trace) with Average limit (blue line). Horizontal polarization and EUT on Y Axis.

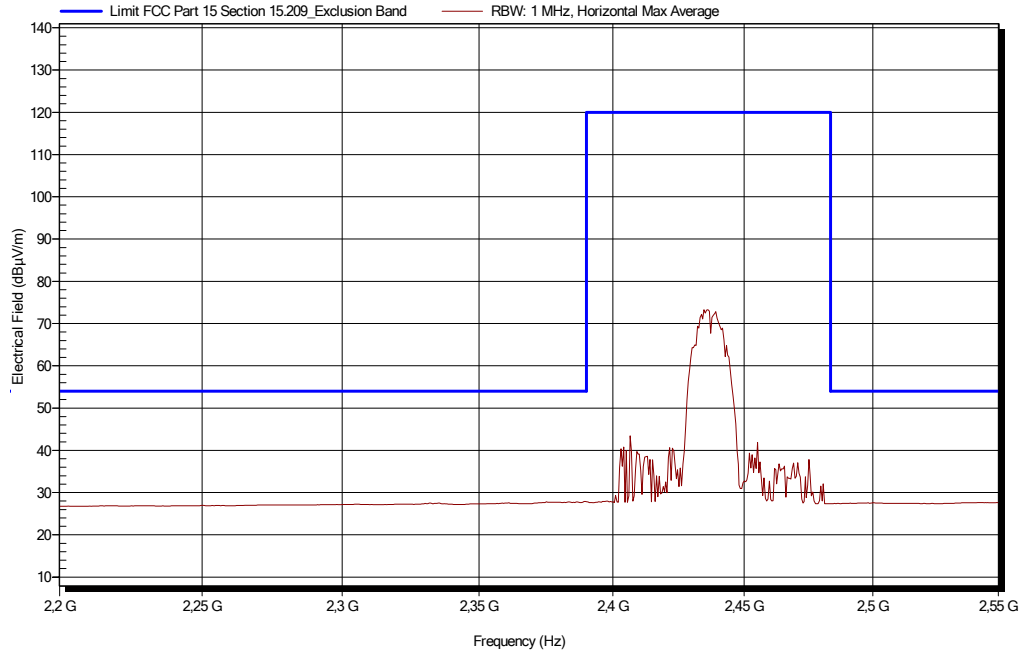



### Measures from 4GHz to 12GHz

Noise floor measured from 4GHz to 12GHz. Peak detector (green trace) with IF=1MHz. Average limit (blue line). Vertical polarization.

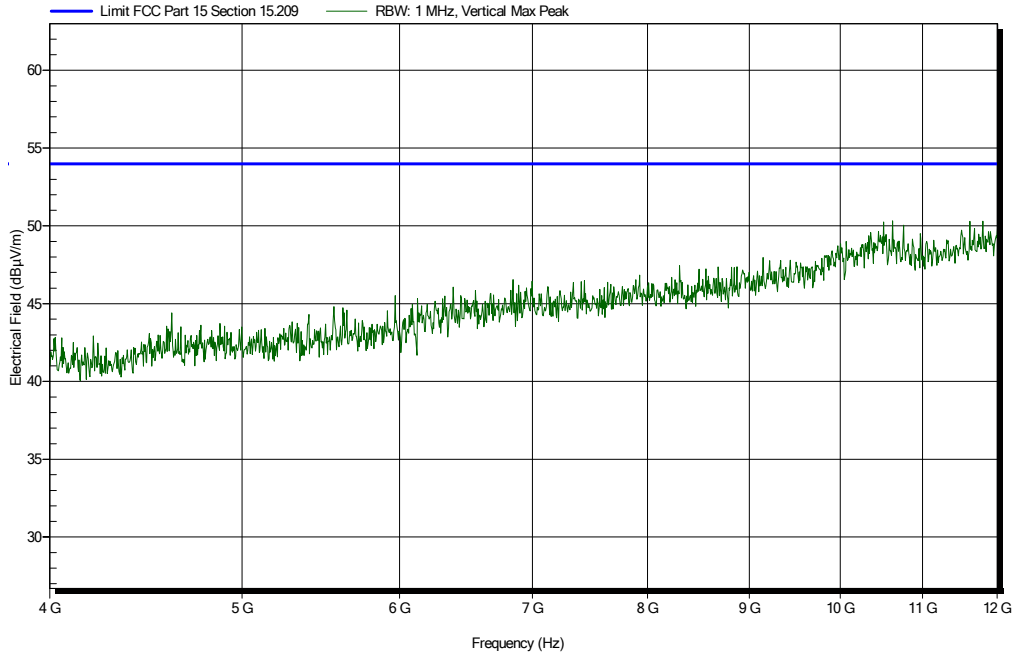

Noise floor measured from 10GHz to 12GHz. Average detector (brown trace) with IF=1MHz. Average limit (blue line). Vertical polarization.

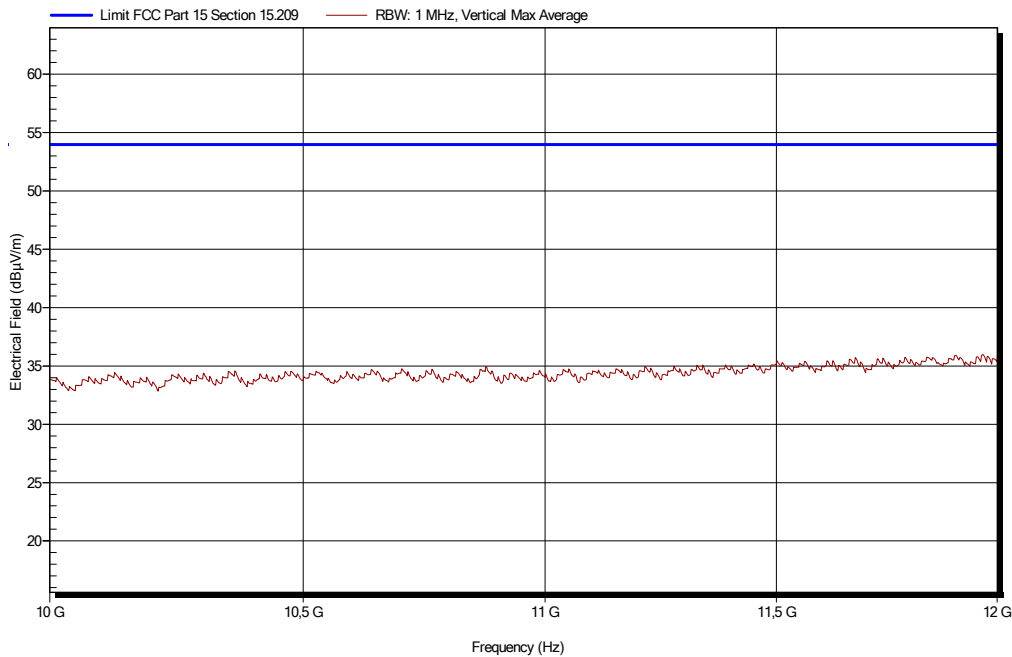

Noise floor measured from 4GHz to 12GHz. Peak detector (green trace) with IF=1MHz. Average limit (blue line). Horizontal polarization.

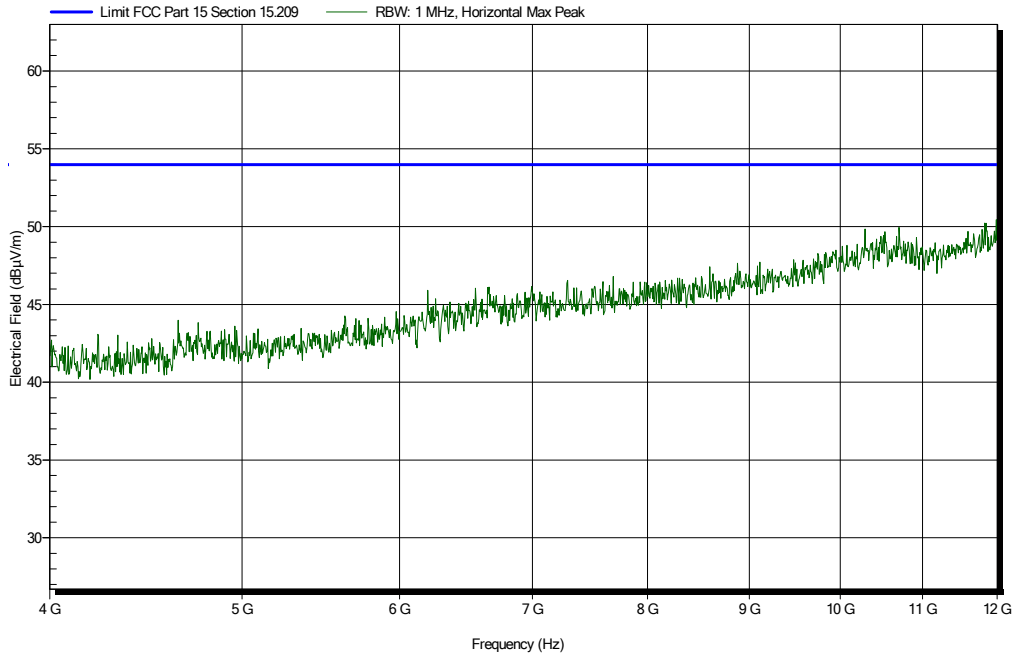

Noise floor measured from 10GHz to 12GHz. Average detector (brown trace) with IF=1MHz. Average limit (blue line). Horizontal polarization.

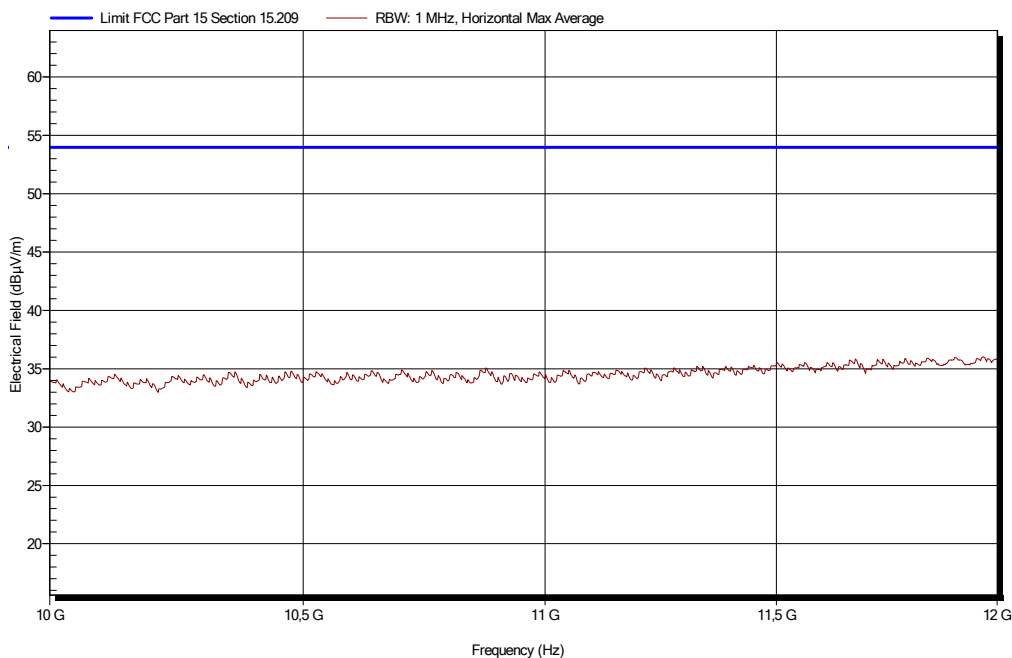

**Measure on EUT**

**(WIFI CH6 at 1Mps) - Worst case detected**

Radiated emissions measured from 4GHz to 12GHz: peak detector (green trace) with Average limit (blue line). Vertical polarization and EUT on Z Axis.

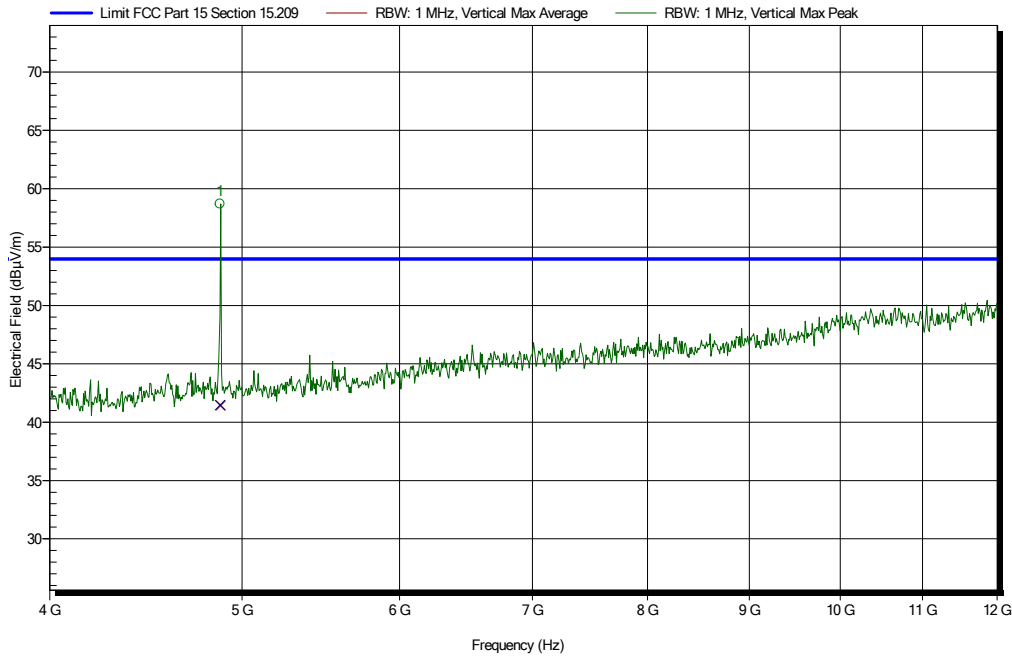

Higher signals, maximized and re-measured with average detector

Frequency [MHz]	Average [dBµV/m]	Average Limit [dBµV/m]	Difference from Limit [dBµV/m]	EUT Angle [°]	Antenna Height [mt]	Result
4874.000	41.5	54.0	-12.6	360	1.70	Pass

Radiated emissions measured from 4GHz to 12GHz: peak detector (green trace) with Average limit (blue line). Horizontal polarization and EUT on Y Axis.

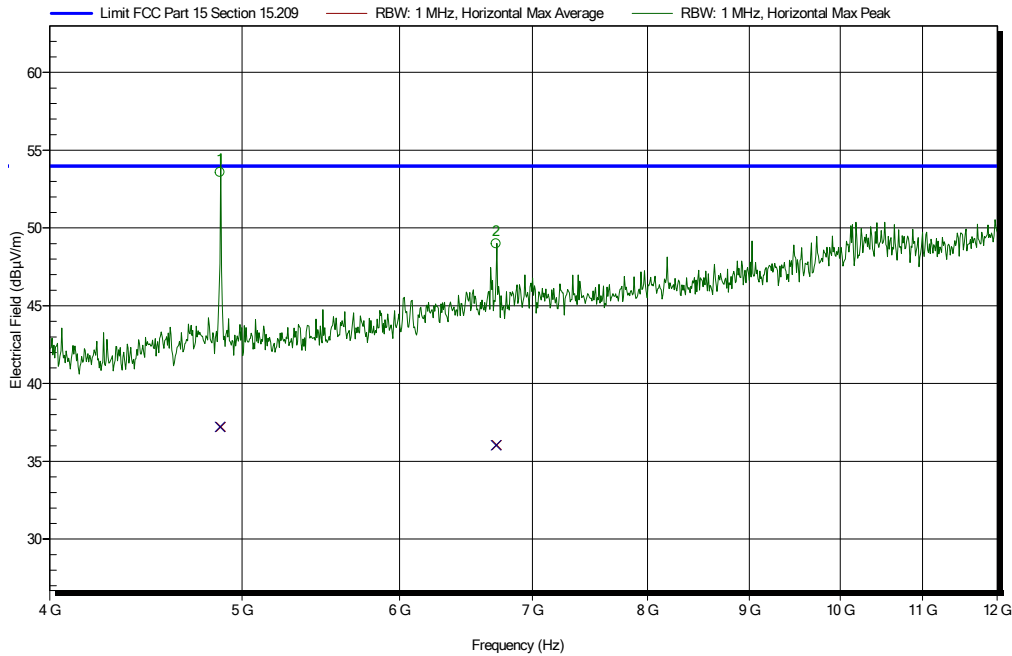

Higher signals, maximized and re-measured with average detector

Frequency [MHz]	Average [dBµV/m]	Average Limit [dBµV/m]	Difference from Limit [dBµV/m]	EUT Angle [°]	Antenna Height [mt]	Result
4875.000	37.2	54.0	-16.8	88	1.80	Pass
6711.000	36.0	54.0	-18.0	98	1.90	Pass

**(Bluetooth CH38 CW) - Worst case detected**

Radiated emissions measured from 4GHz to 12GHz: peak detector (green trace) with Average limit (blue line). Vertical polarization and EUT on Z Axis.

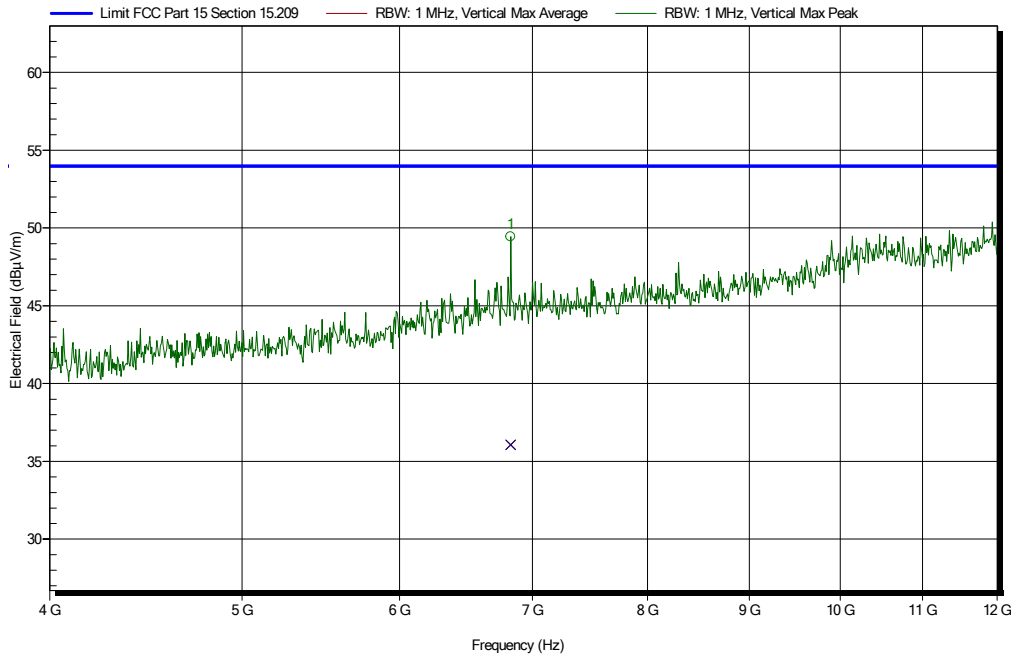

Higher signals, maximized and re-measured with average detector

Frequency [MHz]	Average [dBµV/m]	Average Limit [dBµV/m]	Difference from Limit [dBµV/m]	EUT Angle [°]	Antenna Height [mt]	Result
6826.000	36.1	54.0	-17.9	30	2.40	Pass

Radiated emissions measured from 4GHz to 12GHz: peak detector (green trace) with Average limit (blue line). Horizontal polarization and EUT on Y Axis.

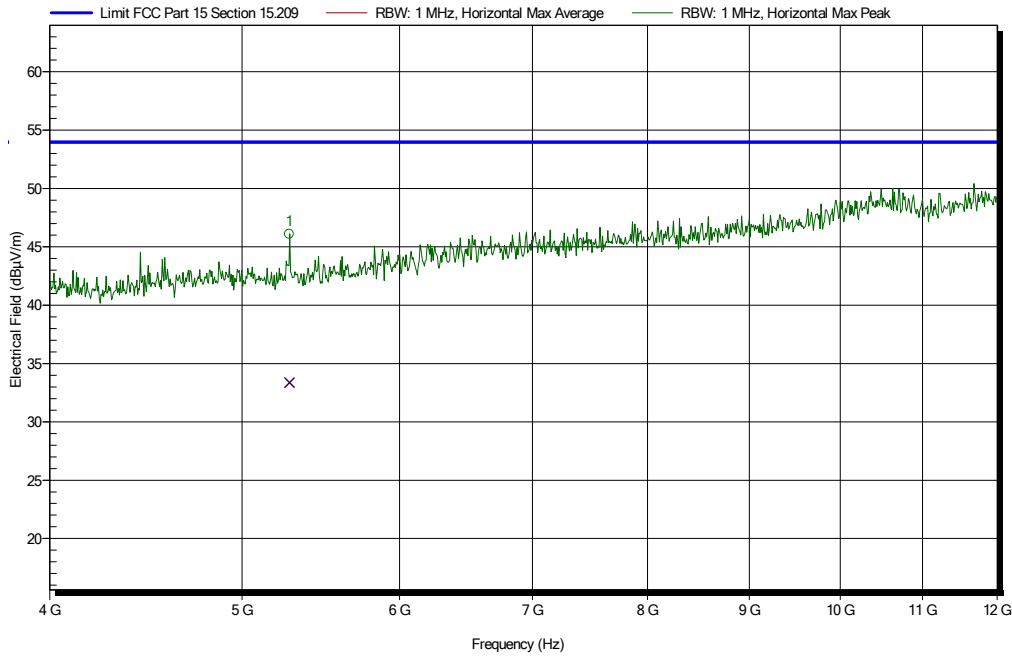

Higher signals, maximized and re-measured with average detector

Frequency [MHz]	Average [dBµV/m]	Average Limit [dBµV/m]	Difference from Limit [dBµV/m]	EUT Angle [°]	Antenna Height [mt]	Result
5282.000	33.4	54.0	-20.6	78	1.70	Pass

**(WIFI CH6 at 1Mbps and Bluetooth Hopping) - Worst case detected**

Radiated emissions measured from 4GHz to 12GHz: peak detector (green trace) with Average limit (blue line). Vertical polarization and EUT on Z Axis

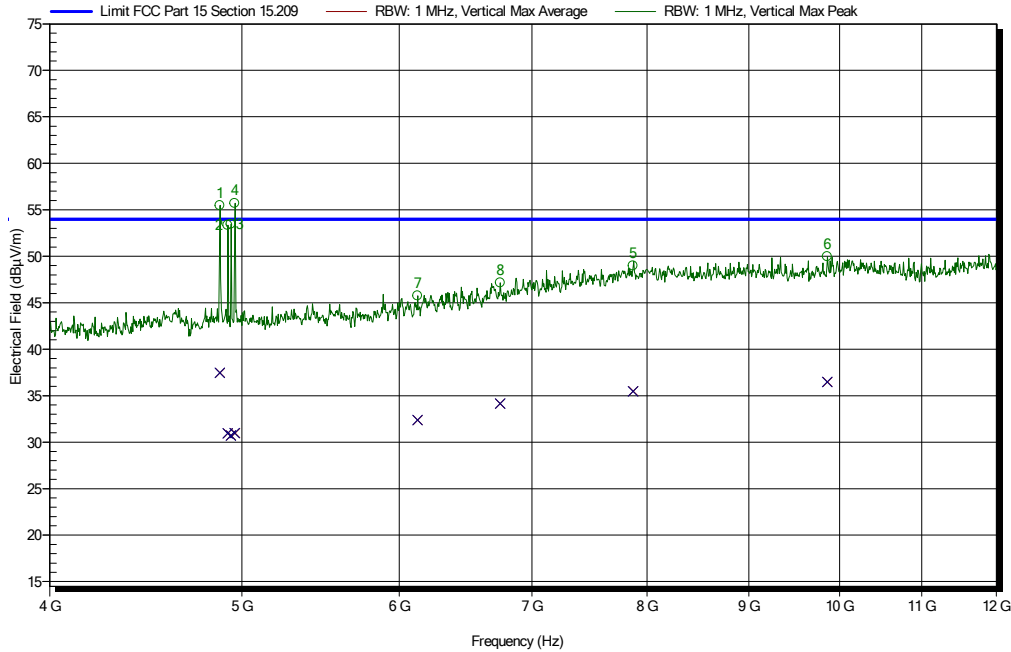

Higher signals, maximized and re-measured with average detector

Frequency [MHz]	Average [dBμV/m]	Average Limit [dBμV/m]	Difference from Limit [dBμV/m]	EUT Angle [°]	Antenna Height [mt]	Result
4874.000	37.5	54.0	-16.5	188	2.00	Pass
4918.000	31.0	54.0	-23.0	23	2.00	Pass
4936.000	30.7	54.0	-23.3	230	1.33	Pass
4958.000	31.0	54.0	-23.0	303	1.33	Pass
6130.000	32.4	54.0	-21.6	228	2.00	Pass
6746.000	34.2	54.0	-19.8	320	1.33	Pass
7870.000	35.5	54.0	-18.5	315	1.67	Pass
9858.000	36.5	55.0	-18.5	98	1.00	Pass

Radiated emissions measured from 4GHz to 12GHz: peak detector (green trace) with Average limit (blue line). Horizontal polarization and EUT on Y Axis

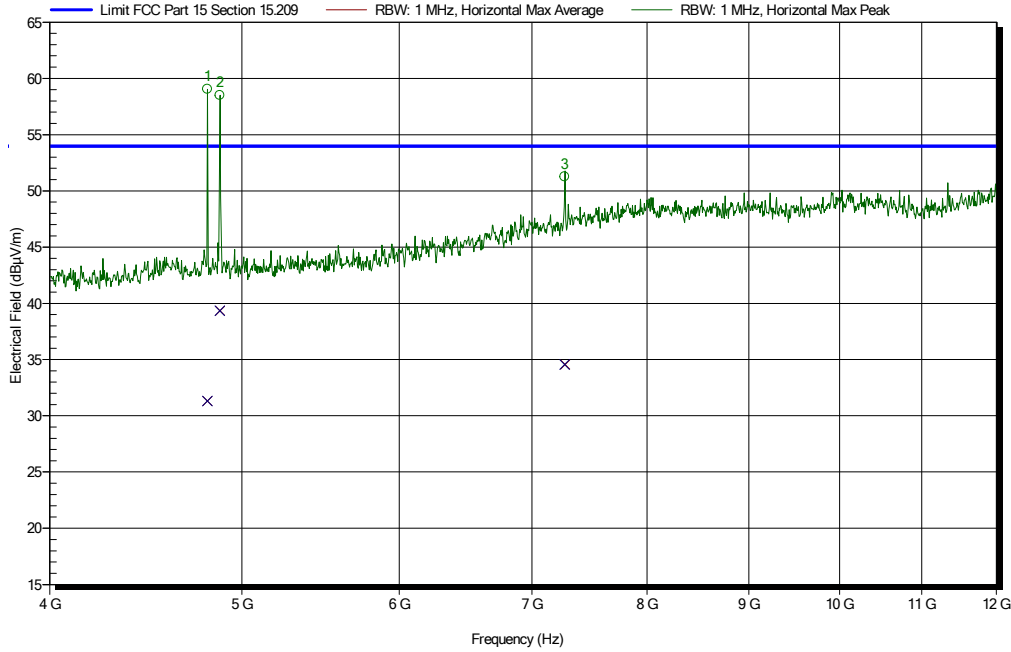

Higher signals, maximized and re-measured with average detector

Frequency [MHz]	Average [dBµV/m]	Average Limit [dBµV/m]	Difference from Limit [dBµV/m]	EUT Angle [°]	Antenna Height [mt]	Result
4804.000	31.3	54.0	-22.7	63	1.00	Pass
4874.000	39.3	54.0	-14.6	58	2.00	Pass
7269.000	34.6	54.0	-19.4	113	1.33	Pass



**Measures from 12GHz to 18GHz**

Noise floor measured from 12GHz to 18GHz. Average detector (brown trace) with IF=1MHz. Average limit (blue line). Vertical polarization.

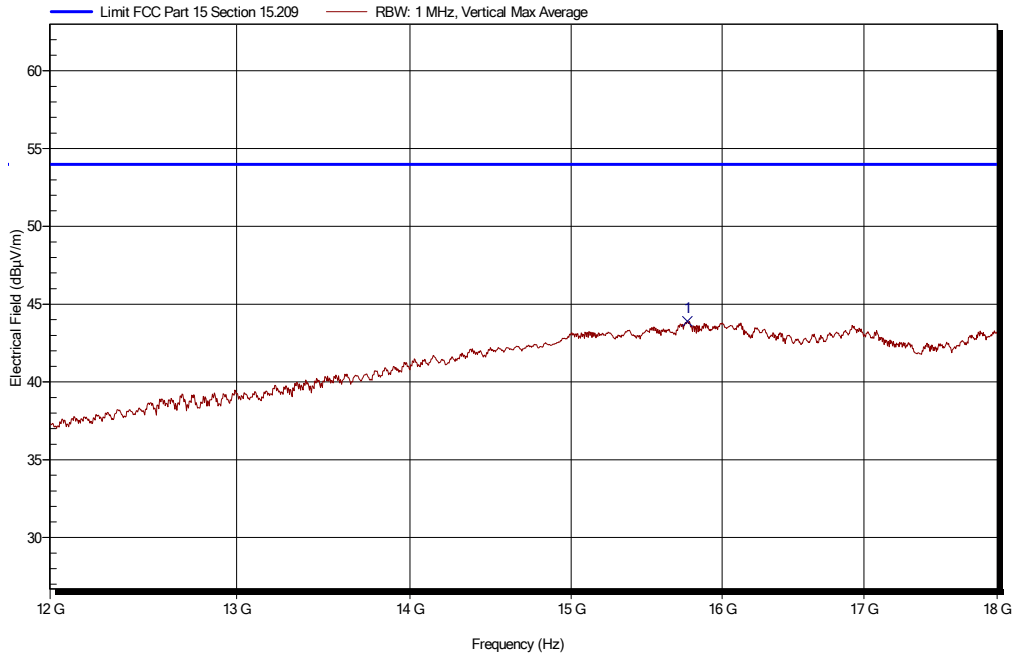

Higher noise detected

Frequency [MHz]	Average [dBµV/m]	Average Limit [dBµV/m]	Difference from Limit [dBµV/m]	EUT Angle [°]	Antenna Height [mt]	Result
15764.000	43.9	54.0	-10.1	0	1.00	Pass

Noise floor measured from 12GHz to 18GHz. Average detector (brown trace) with IF=1MHz. Average limit (blue line). Horizontal polarization.

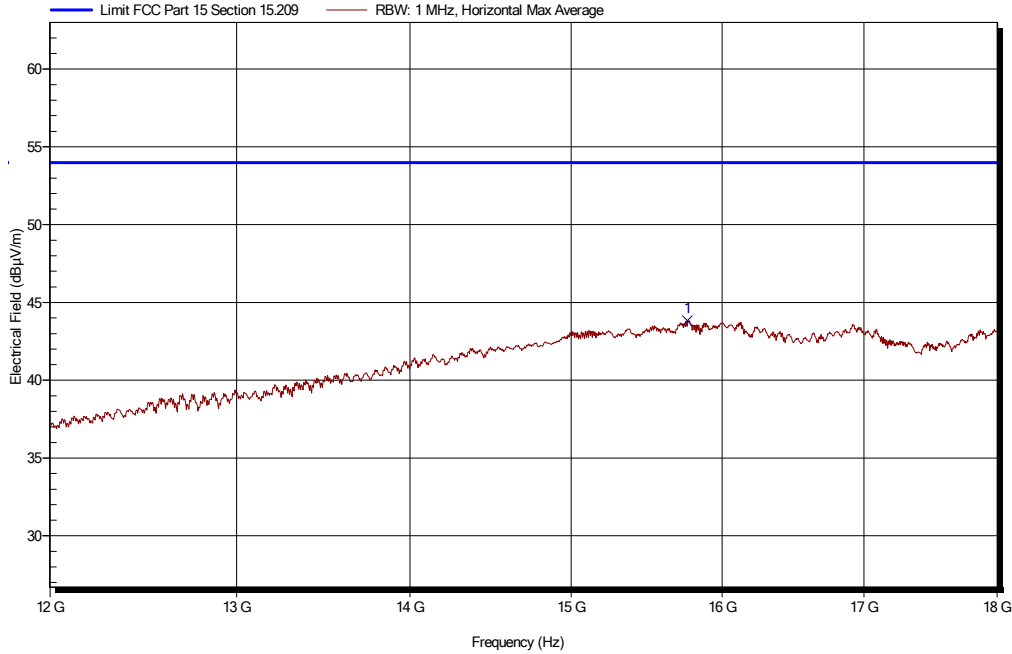

Higher noise detected

Frequency [MHz]	Average [dBµV/m]	Average Limit [dBµV/m]	Difference from Limit [dBµV/m]	EUT Angle [°]	Antenna Height [mt]	Result
15764.000	43.8	54.0	-10.2	0	1.00	Pass

**Measure on EUT:**

No emissions detected above noise level.

**Measures from 18GHz to 25GHz**

Noise floor measured from 12GHz to 25GHz. Average detector (brown trace) with IF=1MHz. Average limit (blue line). Vertical polarization.

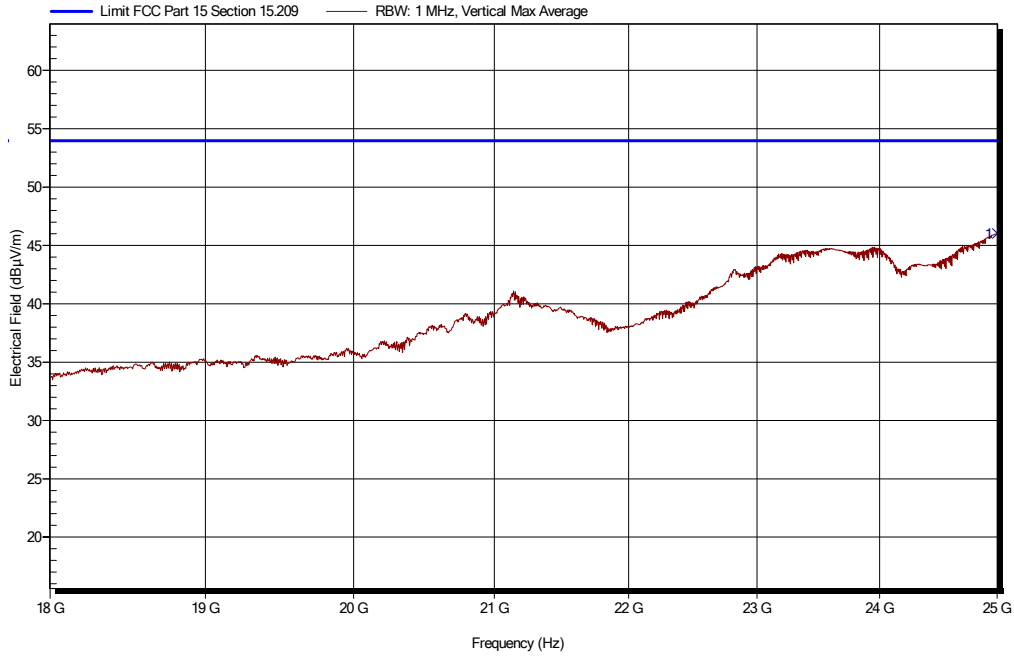

Higher noise detected

Frequency [MHz]	Average [dBµV/m]	Average Limit [dBµV/m]	Difference from Limit [dBµV/m]	EUT Angle [°]	Antenna Height [mt]	Result
24999.000	46.0	54.0	-8.0	0	1.00	Pass

Noise floor measured from 12GHz to 25GHz. Average detector (brown trace) with IF=1MHz. Average limit (blue line). Horizontal polarization.

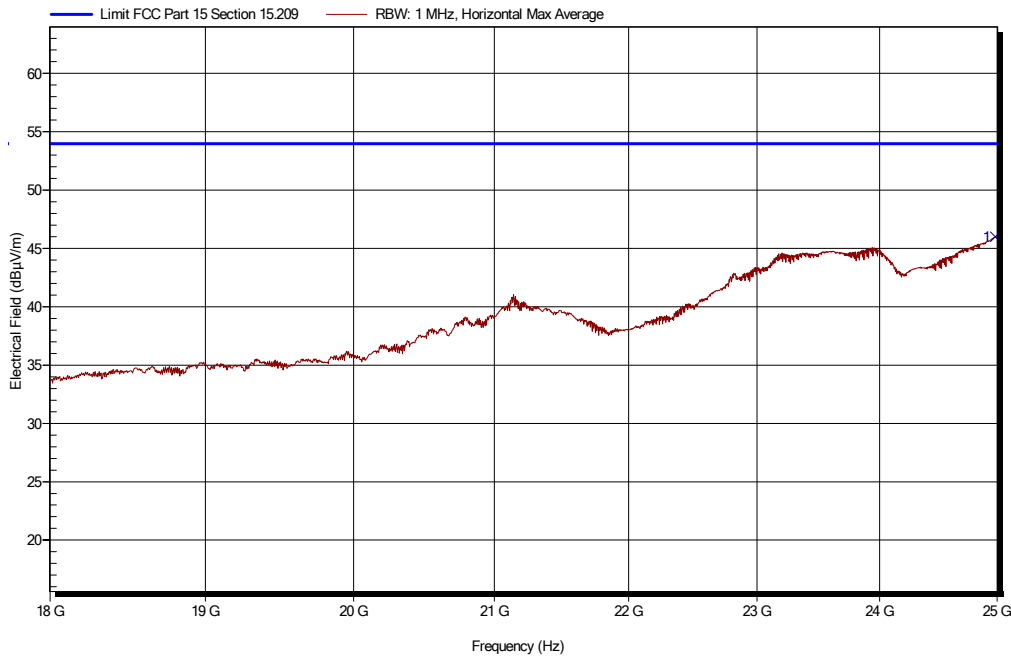

Higher noise detected

Frequency [MHz]	Average [dBµV/m]	Average Limit [dBµV/m]	Difference from Limit [dBµV/m]	EUT Angle [°]	Antenna Height [mt]	Result
24979.000	46.0	54.0	-8.0	0	1.00	Pass

**Measure on EUT:**

No emissions detected above noise level.

## Allegato 2 / Annex 2: Incertezza / Uncertainty

### A.2.1 Radiated Emissions: FCC

From 9kHz to 30MHz using Loop antenna  
Field intensity :  $\pm 4.2$  dB

From 30MHz to 1000MHz using Bilog antenna  
Field intensity :  $\pm 4.7$  dB

From 1GHz to 18GHz using Horn antenna  
Field intensity :  $\pm 4.9$  dB

### A.2.2 Conducted Emissions: FCC

Voltage Method :  $\pm 2.6$  dB

### A.2.3 Radio test

Conducted output power :  $\pm 2.1$  dB

Conducted adjacent channel power :  $\pm 1.6$  dB

Conducted Bandwidth :  $\pm 9.1$  KHz (Span=40M, RBW=430KHz, 1000pti)  
:  $\pm 7.7$  KHz (Span=40M, RBW=100KHz, 1000pti)  
:  $\pm 10.6$  KHz (Span=80M, RBW=100KHz, 1000pti)

Conducted spurious emission :  $\pm 3.7$  dB