

TEST REPORT

Secondo i seguenti Standard / *According to following Standards*

Test specification	FCC Part 15: Subpart C Section 15.247: 2015	
	Test plan: TP-15LA00198/01_151008_REGATE-10-11-16	
Maximum Conducted Output Power, Section 15.247 (a) (1) for BT		Conforme/ Compliant
20dB Bandwidth, Section 15.247 (a) (1) for BT		Conforme/ Compliant
Band-edge Compliance, Section 15.247(d) for BT		Conforme/ Compliant
Number of Hopping Channels, Section 15.247 (a)(1)(iii) for BT		Conforme/ Compliant
Hopping Channel Separation, Section 15.247 (a)(1) for BT		Conforme/ Compliant
Dwell Time, Section 15.247 (a)(1)(iii) for BT		Conforme/ Compliant
Conducted Spurious Emissions, Section 15.247(d) for BT		Conforme/ Compliant
Richiedente/ Applicant's name :	Eurotech Spa	
Indirizzo / Address	Via F.lli Solari 3/A – 33020 Amaro (UD) - Italy	
Produttore / Manufacturer :	Eurotech Spa	
Indirizzo / Address	Via F.lli Solari 3/A – 33020 Amaro (UD) - Italy	
Dispositivo sottoposto ai test/ Device Under Test :	ReliaGATE 10-11-16	
Data di emissione/ Date of issue	23 rd February 2016	
Validità/ Validity	Vedi sezione 1.1 / <i>See section 1.1</i>	
Test report redatto da/ Author of Test report	Loris Fruch	
Tecnico/i di prova Engineer/s	Loris Fruch	
	Responsabile di prova/ <i>Test manager</i> : Giovanni Solari	
Approvato da (+ firma) Approved by (+ signature)	Silvano Chialina	
	Responsabile del laboratorio/	
	<i>Head of the Laboratory</i>	
Laboratorio / Testing Laboratory :	EmilabSrl	
Indirizzo / Address	Via F.lli Solari 5/A – 33020 Amaro (UD) - Italy	

Index

1.	INFORMAZIONI GENERALI / GENERAL INFORMATION	4
1.0	Laboratorio / Testing Laboratory	4
1.1	Campionamento e Documentazione / Sampling and Documentation	4
1.2	Specifiche del test / Test specifications	4
1.3	Svolgimento dei test e condizioni generali / Test scheduling and general condition	5
1.4	Espressione dei risultati finali / Test case of final verdicts	5
1.5	Incertezza / Uncertainty	6
1.6	Termini, Definizioni e Acronimi/ Terms, definitions and abbreviations	6
2.0	APPARECCHIATURA SOTTOPOSTA A TEST/ DEVICE UNDER TEST	7
2.1	CHANNEL LIST	9
2.3	SELECTED MODULATION MODES AND CHANNEL DETAILS	9
3.0	MAXIMUM CONDUCTED OUTPUT POWER-CONDIZIONI DI PROVA / TEST CONDITIONS	10
3.1	Apparecchiature utilizzate / Test Equipment Used – Maximum Conducted Output Power	10
3.2	Fotografie del setup / Photo of the test setup –Maximum Conducted Output Power	11
3.3	Risultati / Results - Maximum Conducted Output Power	11
3.3.1	Tabelle e grafici dei risultati / Tables and graphical representation of data – Maximum Conducted Output Power	11
4.0	BANDWIDTH - CONDIZIONI DI PROVA / TEST CONDITIONS	14
4.1	Apparecchiature utilizzate / Test Equipment Used – Maximum Peak Conducted Output Power	14
4.2	Fotografie del setup / Photo of the test setup –Bandwidth	15
4.3	Risultati / Results - Bandwidth	15
4.3.1	Tabelle e grafici dei risultati / Tables and graphical representation data –Bandwidth	15
5.0	BAND-EDGE COMPLIANCE - CONDIZIONI DI PROVA / TEST CONDITIONS	17

5.1	Apparecchiature utilizzate / <i>Test Equipment Used</i> – Maximum Peak Conducted Output Power	17
5.2	Fotografie del setup / <i>Photo of the test setup</i> –Band-edge Compliance	18
5.3	Risultati / <i>Results</i> - Band-edge Compliance	18
5.3.1	Tabelle e grafici dei risultati / <i>Tables and graphical representation of data</i> – <i>Band-edge Compliance</i>	18
6.0	HOPPING VERIFICATIONS - CONDIZIONI DI PROVA / <i>TEST CONDITIONS</i>	20
6.1	Apparecchiature utilizzate / <i>Test Equipment Used</i> – Hopping Verifications	20
6.2	Fotografie del setup / <i>Photo of the test setup</i> –Hopping Verifications	21
6.3	Risultati / <i>Results</i> – Hopping Verifications	21
6.3.1	Tabelle e grafici dei risultati / <i>Tables and graphical representation of data</i> –Hopping Verifications	21
7.1	Apparecchiature utilizzate / <i>Test Equipment Used</i> – Maximum Peak Conducted Output Power	25
7.2	Fotografie del setup / <i>Photo of the test setup</i> –Conducted Spurious Emissions	26
7.3	Risultati / <i>Results</i> - Conducted Spurious Emissions	26
7.3.1	Grafici dei risultati / <i>Graphical representation data</i> – Conducted Spurious Emissions	27
	Allegato 2 / Annex 2: Incertezza / Uncertainty	28

1. Informazioni Generali / *General Information*

1.0 Laboratorio / *Testing Laboratory*

Luogo di Prova e partecipanti / <i>Testing location and participants:</i>	
Testing Laboratory:	
Testing location/ address.....:	EmilabSrl Via F.lli Solari 5/A – 33020 Amaro (UD) – Italy Tel +39 0433 468625 Fax +39 0433 494739 Email: info@emilab.it
Partecipanti / <i>Participants:</i>	Loris Fruch, Pierluigi Pollano (Eurotech Spa), Pierluigi Driusso (Eurotech Spa)

1.1 Campionamento e Documentazione / *Sampling and Documentation*

I campioni sono stati consegnati dal Cliente. I risultati dei test contenuti in questo documento si riferiscono esclusivamente al modello e numero di serie provato. E' responsabilità del costruttore assicurare che la produzione dei modelli in serie rispetti i requisiti del presente documento. Questo documento non può essere riprodotto in parte senza il consenso scritto del responsabile del laboratorio EMILAB.

EMILAB non si assume nessuna responsabilità per danni derivanti da interpretazioni che esulano dal contesto e dall'applicazione del presente documento.

The samples was delivered by customer. The results contained in this report reflect the results for this particular model and serial number. It is the responsibility of the manufacturer to ensure that all production models meet the intent of the requirements detailed within this report. This report shall not be reproduced, except in full, without the written approval of the Issuing testing Emilab laboratory.

EMILAB takes no responsibility for and will not assume liability for damages resulting from the reader's interpretation of the reproduced material due to its placement and context.

1.2 Specifiche del test / *Test specifications*

Test performed according to:	
Test plan	TP-15LA00198/01_151008_REGATE-10-11-16 Date:08/10/2015 Author: Stefano Zanolin - Eurotech S.p.A.
Test specification	FCC CFR 47 - Part 2 and Part 15:2015 (Subpart B e C)
Basic Specifications	ANSI C63.10: 2009-09 American National Standard for Testing Unlicensed Wireless Devices. <i>Frequency Range of the accreditation scope of the Lab. (ACCREDIA): up to 18GHz.</i>

1.3 Svolgimento dei test e condizioni generali / Test scheduling and general condition

Svolgimento dei test/ Scheduling	
Data ricezione EUT	
<i>Date of receipt of EUT</i>	29/10/2015
Data esecuzione test	
<i>Date (s) of performance of tests</i>	04/11/2015 – 23/02/2016
Condizioni ambientali <i>/ Environment Conditions</i>	Se non diversamente specificato / <i>If not otherwise specified:</i> Temperature: 18-28°C Humidity: 20-90% Pressure: 87-108.56 kPa
Intervallo delle tarature/ <i>Calibration Interval</i>	Minimum 1 year

1.4 Espressione dei risultati finali / Test case of final verdicts

I GIUDIZI NON SONO SOGGETTI AD ACCREDITAMENTO

/ VERDICTS ARE NOT SUBJECT TO ACCREDITATION

- test case does not apply to the test object..... : N/A
- test object does meet the requirement..... : Compliant or PASS
- test object does not meet the requirement : Not Compliant or FAIL

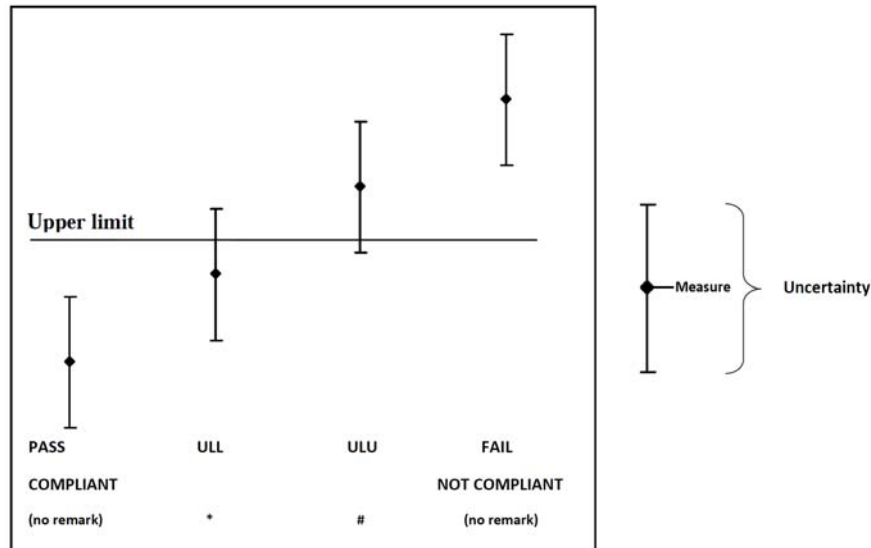

Results marked with a NOT COMPLIANT or FAIL do not meet specifications with a probability of >95%, the total uncertainty interval is located outside the specified limits.

Measurement results are marked with an "*" or "#" (uncertain) if the uncertainty interval is partly within and partly out of the specified limits. A clear compliance statement is not possible.

All results not marked are located within the specified limits even when extended by the uncertainty interval

1.5 Incertezza / Uncertainty

L'incertezza estesa riportata è espressa come l'incertezza tipo moltiplicata per il fattore di copertura $k = 2$, che per una distribuzione normale corrisponde ad una probabilità di copertura di circa il 95 %.

The reported expanded uncertainty of measurements is stated as the standard uncertainty of measurement, multiplied by the coverage factor $k=2$, which for a normal distribution corresponding to a coverage probability of approximately 95%.

1.6 Termini, Definizioni e Acronimi/ Terms, definitions and abbreviations

AC	Alternating Current
ACK	Acknowledgement
AFH	Adaptive Frequency Hopping
AM	Amplitude modulation
AVE det	Average Detector
BIT	Burst Interval Time
CAC	Channel Availability Check
BW	BandWidth
CCA	Clear Channel Assessment
CW	Continuous Wave
DAA	Detect And Avoid
DC	Duty CycleDFS
DFS	Dynamic Frequency Selection
DSSS	Direct Sequence Spread Spectrum
DUT	Device Under Test
e.i.r.p.	equivalent isotropically radiated power
e.r.p.	effective radiated power
EMC	Electro Magnetic Compatibility
EUT	Equipment Under test
FAR	Fully Anechoic Room
FHSS	Frequency Hopping Spread Spectrum
HT20 High	Throughput in a 20 MHz channel
HT40 High	Throughput in a 40 MHz channel
ISM	Industrial, Scientific and Medical
LBT	Listen Before Talk
LPDA	Logarithmic Periodic Dipole Antenna
MCS	Modulation Coding Scheme
MIMO	Multiple Input, Multiple Output
MU	Medium Utilisation
MS/s	Mega-Samples per second
NACK	Not Acknowledged
OATS	Open Air Test Site
OFDM	Orthogonal Frequency Division Multiplexing
OM	Operating Modes
OOB	Out Of Band
PK det	Peak Detector
PM	pulse modulation
Ppm	parts per million
PPS	Pulses Per Second
PRF	Pulse Repetition Frequency
RBW	Resolution BandWidth
RE	Radiated Emission
RLAN	Radio Local Area Network
RMS	Root Mean Square
R&TTE	Radio and Telecommunications Terminal Equipment
RF	Radio Frequency
Rx	Receiver
SAC	Semi Anechoic Chamber
TEM	transverse electromagnetic
TL	Threshold Level
TPC	Transmit Power Control
Tx	Transmitter
VBW	Video BandWidth
VSWR	voltage standing wave ratio
WLAN	Wireless Local Area Network
BT	Bluetooth
BLE	Bluetooth Low Energy

2.0 Apparecchiatura sottoposta a test/ *Device Under Test*

Descrizione/ <i>Description</i>:	The ReliaGATE 10-11-16 is a compact and lightweight IoT gateway based on the powerful TI AM 335X microprocessor. It integrates 4 GB of eMMC storage that can be expanded using the MicroSD card slot available behind the Service panel.
Marchio commercial / <i>Trade Mark</i>:	
Produttore / <i>Manufacturer</i>:	Eurotech Spa
Modello / <i>Model/Type reference</i>:	REGATE-10-11-16
Voltage/Current.....:	9±36Vdc (nominal 24Vdc) / 0.1A
Frequency.....:	/
Power.....:	2.5W
Numero EUT / <i>EUT Number</i>:	15LA00198/01
Serial Number.....:	R1YYMDL0000
Numero di campioni testati / <i>Number of samples tested</i>:	1
Hardware stage/level.....:	1.0
Software stage/level.....:	1.0
Modification stage.....:	/
Operating Mode.....:	<p>Mode 1 (conducted measurements): the EUT is connected only to power supply line and WLAN/Bluetooth antenna output (50ohm, SMA) is connected to the Spectrum Analyser. Bluetooth was set using the test routine ".fccbluetooth.sh" provided by the applicant .</p> <p>During all tests the DUT BT transmitter was set at it maximum Tx-power, as per control software setting.</p>
Wiring harness.....:	Power supply Harness (2mt length);
Monitoring.....:	/

Info:

Other Emilab reports related to the same product: (WLAN:15-02125, BLE: 16-02235, RF Exposure:16-02236)

The test results collected in this report are confirmed in all the voltage range of EUT power supply (9÷36V dc).

DUT Hardware features

Processor: TI AM335X, 800 MHz, 1 core, RAM: 512MB DDR3, Embedded storage: 4GB eMMC, Additional storage Micro SD card slot available behind the Service panel

Wired Interfaces:

- Ethernet: 1 x Fast Ethernet port (external)
- CAN: 2 x CAN ports (Version 2 Parts A and B)
- USB: 2 x USB 2.0 host port, 1x USB 2.0 client port
- Serial: 1x TTL for OS console (available behind the Service panel) 2x RS232/485 configurable
- Digital I/O: 2 x insulated digital inputs and 2x insulated digital outputs

Wireless Interfaces:

- Cellular: 3G global, Telit HE910 DG
- Wi-Fi: 802.11 b/g/n
- Bluetooth: 4.0
- GPS: 28-channel GPS integrated in Cellular
- RF output connectors: 1 x SMA for Cellular, 1x SMA for GPS, 1x SMA for Wi-Fi/Bluetooth

Antenna:

- Multi band antenna Mobile Mark, model SMW-UMB-3C3C3C with integral RF coaxial cables L=4mt;

ESA modifications at manufacturer's care:

- Before of the tests a ferrite model "Fair-rite 0431164281" was placed with one turn on the EUT power supply cable near to its case;

Auxiliary equipment for tests supplied by the applicant:

- Personal Computer Acer, model Travelmate C300;

GSM dotation Telit HE910 FCC ID: RI7HE910

2.1 Channel List

Bluetooth

Frequency band [MHz]: 2400 – 2483.5							
Channel	Frequency [MHz]	Channel	Frequency [MHz]	Channel	Frequency [MHz]	Channel	Frequency [MHz]
0	2402	20	2422	40	2442	60	2462
1	2403	21	2423	41	2443	61	2463
2	2404	22	2424	42	2444	62	2464
3	2405	23	2425	43	2445	63	2465
4	2406	24	2426	44	2446	64	2466
5	2407	25	2427	45	2447	65	2467
6	2408	26	2428	46	2448	66	2468
7	2409	27	2429	47	2449	67	2469
8	2410	28	2430	48	2450	68	2470
9	2411	29	2431	49	2451	69	2471
10	2412	30	2432	50	2452	70	2472
11	2413	31	2433	51	2453	71	2473
12	2414	32	2434	52	2454	72	2474
13	2415	33	2435	53	2455	73	2475
14	2416	34	2436	54	2456	74	2476
15	2417	35	2437	55	2457	75	2477
16	2418	36	2438	56	2458	76	2478
17	2419	37	2439	57	2459	77	2479
18	2420	38	2440	58	2460	78	2480
19	2421	39	2441	59	2461	-	-

2.3 Selected Modulation Modes and Channel Details

Bluetooth

Test Item	Mode	Test Frequency [MHz]	Data Rate
Maximum Conducted Output Power	GFSK $\pi/4$ DQPSK 8DPSK	2402 / 2440 / 2480	1Mbps (BR) 2Mbps (EDR) 3Mbps (EDR)
Conducted Spurious Emissions	GFSK 8DPSK	Hopping OFF&ON 2402 / 2480	1Mbps (BR) 3Mbps (EDR)
Band-edge Compliance	GFSK 8DPSK	Hopping OFF&ON 2402 / 2480	1Mbps (BR) 3Mbps (EDR)
20dB Bandwidth	GFSK 8DPSK	2402 / 2440 / 2480	1Mbps (BR) 3Mbps (EDR)
Number of Hopping Frequency	GFSK 8DPSK	Hopping ON	1Mbps (BR) 3Mbps (EDR)
Hopping Channel Separation	GFSK 8DPSK	2402 / 2440 / 2480	1Mbps (BR) 3Mbps (EDR)
Dwell Time	GFSK 8DPSK	2402 Hopping ON	1Mbps (BR) 3Mbps (EDR)

3.0 Maximum Conducted Output Power-Condizioni di prova / Test Conditions

Technician / Tecnico: Loris Fruch		
Table No.	TEST: Maximum Conducted Output Power , Section 15.247 (a) (1)	\
Method	ANSI C63.10: 2009-09, par. 6.10.1	\
Parameters required prior to the test	Laboratory Ambient Temperature	18 to 28 °C
	Relative Humidity	20 to 90%
Parameters recorded during the test	Laboratory Ambient Temperature	21 °C
	Relative Humidity	52 - 54 %
Supplementary information:		
<ul style="list-style-type: none"> - Conducted Test, executed at WLAN/Bluetooth antenna output (50ohm, SMA) connected to the Spectrum Analyser through an attenuator (30 dB); - EUT powered at 24Vdc; - EUT Operating Mode: Mode1 (see par. 2.0); - Spectrum analyser settings setup: <ul style="list-style-type: none"> • Detector: Peak • RBW: 3MHz and VBW=3MHz • Instrument mode: Max Hold - Test executed with the following BT settings: <ul style="list-style-type: none"> • BR mode with modulation GFSK on channel 0, 38 and 78 with data rate at 1Mbps • EDR mode with modulation $\pi/4$ DQPSK on channel 0, 38 and 78 with data rate at 2Mbps • EDR mode with modulation 8DPSK on channel 0, 38 and 78 with data rate at 3Mbps 		

3.1 Apparecchiature utilizzate / Test Equipment Used – Maximum Conducted Output Power

<i>Apparecchiature usate/Equipment Used</i>	<i>Modello/Model</i>	<i>Costruttore/Manufacturer</i>	<i>Numero di serie/Serial Number</i>	<i>Data calibrazione / Calibration date</i>	<i>Intervallo / Interval</i>
EMI Receiver MXE	N9038A	Agilent Technologies	MY51210230	05/2015	1 year
30dB Attenuator	PE7087-30	Pasternack	EL082315	09/2015	1 year

3.2 Fotografie del setup / *Photo of the test setup* –Maximum Conducted Output Power

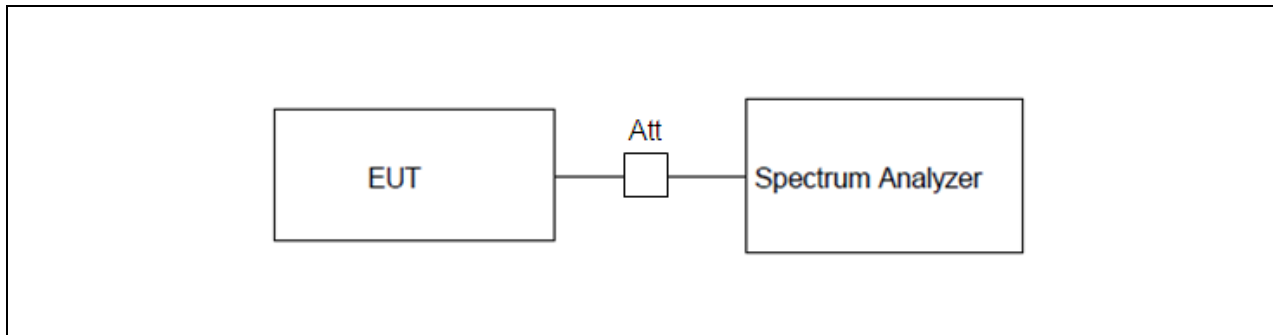

3.3 Risultati / *Results* - Maximum Conducted Output Power

The result of the test is: **PASS**. See the details in the charts/tables of the following paragraphs (see the worst case in bold text).

3.3.1 Tabelle e grafici dei risultati / *Tables and graphical representation of data* – Maximum Conducted Output Power

Measures executed on Bluetooth

Note: all the traces reported in this section have been obtained with Peak detector, Max Hold.

Modulation mode	Data Rate (Mbps)	Channel Frequency (MHz)	Peak Output Power (dBm)	Limit (dBm)	Margin (dB)
GFSK	1	2402.0	5.0	21.0	16.0
		2440.0	4.6	21.0	16.4
		2480.0	4.1	21.0	16.9
$\pi/4$ DQPSK	2	2402.0	1.7	21.0	19.3
		2440.0	1.3	21.0	19.7
		2480.0	0.8	21.0	20.2
8DPSK	3	2402.0	1.3	21.0	19.7
		2440.0	2.7	21.0	18.3
		2480.0	1.3	21.0	19.7

Channel Frequency: 2402 MHz, (GFSK) Data Rate: 1Mbps

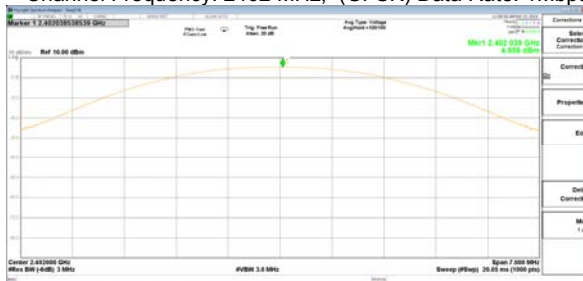

Channel Frequency: 2440 MHz, (GFSK) Data Rate: 1Mbps

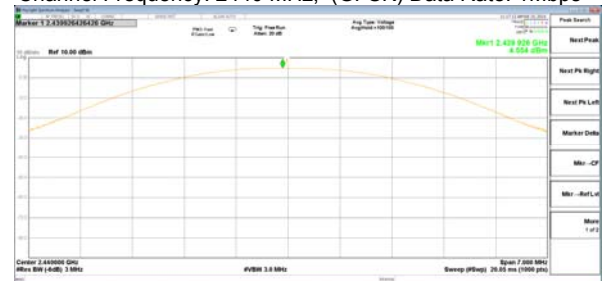

Channel Frequency: 2480 MHz, (GFSK) Data Rate: 1Mbps



Channel Frequency: 2402 MHz, ($\pi/4$ DQPSK) Data Rate: 1Mbps

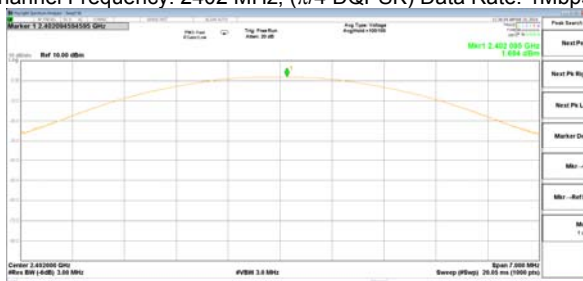

Channel Frequency: 2440 MHz, ($\pi/4$ DQPSK) Data Rate: 1Mbps

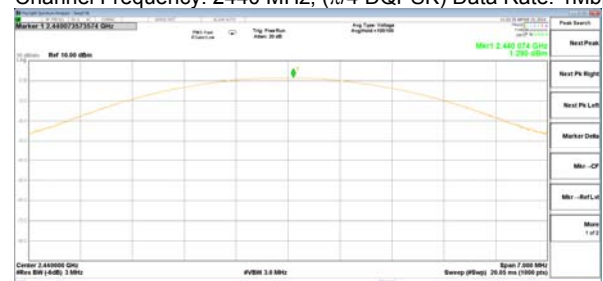

Channel Frequency: 2480 MHz, ($\pi/4$ DQPSK) Data Rate: 1Mbps

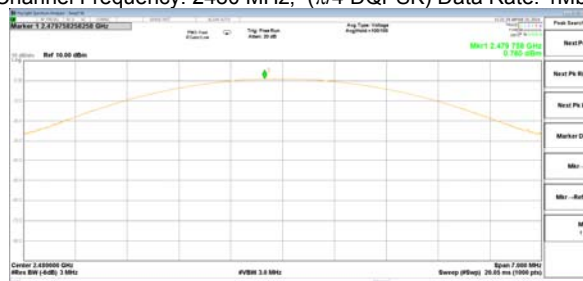

LAB N° 0986

Channel Frequency: 2402 MHz, (8DPSK) Data Rate: 1Mbps

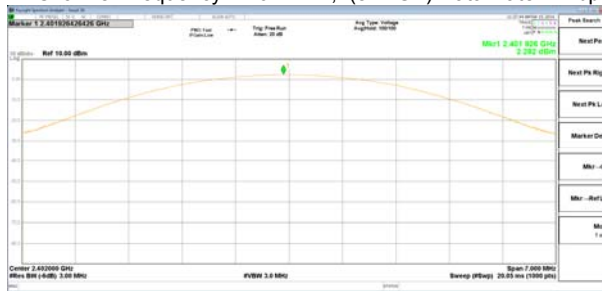

Channel Frequency: 2440 MHz, (8DPSK) Data Rate: 1Mbps

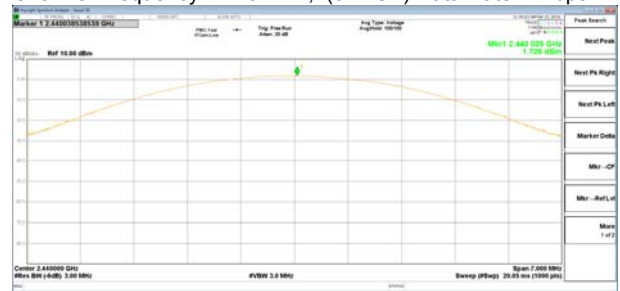

Channel Frequency: 2480 MHz, (8DPSK) Data Rate: 1Mbps

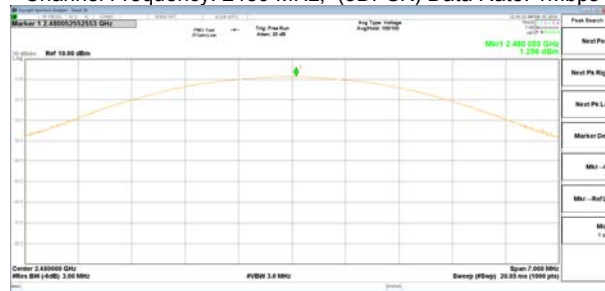

4.0 Bandwidth - Condizioni di prova / Test Conditions

Technician / Tecnico: Loris Fruch		
Table No.	TEST: 20dB Bandwidth, Section 15.247 (a) (1) for BT	\
Method	ANSI C63.10: 2009-09, par. 6.9.1	\
Parameters required prior to the test	Laboratory Ambient Temperature	18 to 28 °C
	Relative Humidity	20 to 90 %
Parameters recorded during the test	Laboratory Ambient Temperature	20 °C
	Relative Humidity	51 %
Supplementary information:		
<ul style="list-style-type: none"> - Conducted Test, executed at WLAN/Bluetooth antenna output (50ohm,SMA) connected to the Spectrum Analyser through an attenuator (30 dB); - EUT powered at 24Vdc; - EUT Operating Mode: Mode1 (see par. 2.0); - Spectrum analyser settings setup: automatic bandwidth measurement Detector: Peak, Trace: max hold (over last 10 sweeps), - RBW: 30 kHz; - VBW=3xRBW; - Test executed with the following BT settings: <ul style="list-style-type: none"> • BR mode with modulation GFSK on channel 0, 38 and 78 with data rate at 1Mbps • EDR mode with modulation 8DPSK on channel 0, 38 and 78 with data rate at 3Mbps 		

4.1 Apparecchiature utilizzate / Test Equipment Used – Maximum Peak Conducted Output Power

<i>Apparecchiature usate/Equipment Used</i>	<i>Modello/Model</i>	<i>Costruttore/Manufacturer</i>	<i>Numero di serie/Serial Number</i>	<i>Data calibrazione / Calibration date</i>	<i>Intervallo / Interval</i>
EMI Receiver MXE	N9038A	Agilent Technologies	MY51210230	05/2015	1 year
30dB Attenuator	PE7087-30	Pasternack	EL082315	09/2015	1 year

4.2 Fotografie del setup / Photo of the test setup –Bandwidth

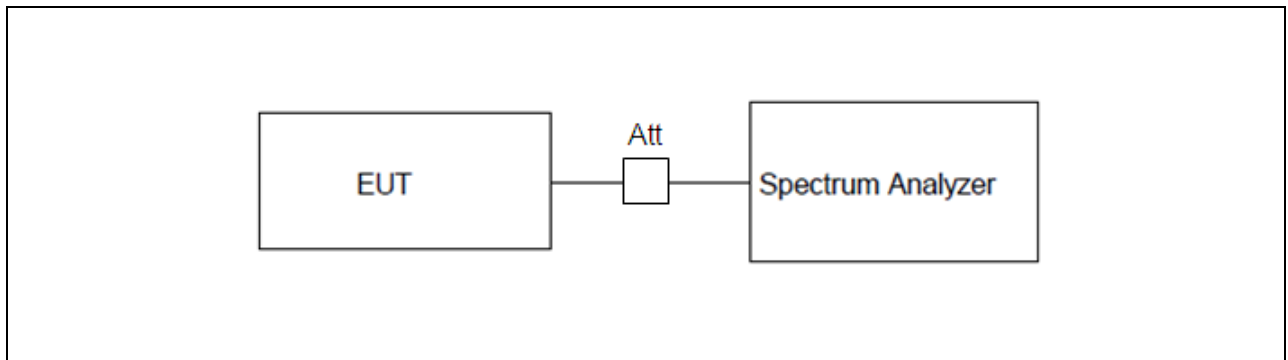

4.3 Risultati / Results - Bandwidth

Bluetooth:

The 20dB bandwidth is used to verify conformity to the channel separation requirement (see par. 7.0). See the details in the charts/tables of the following paragraphs.

4.3.1 Tabelle e grafici dei risultati / Tables and graphical representation data – Bandwidth

Measures executed on Bluetooth

Modulation mode	Data Rate (Mbps)	Channel Frequency (MHz)	20dB Bandwidth (MHz)	99% Bandwidth (MHz)
GFSK	1	2402.0	0.954	0.866
		2440.0	0.949	0.856
		2480.0	0.956	0.875
8DPSK	3	2402.0	1.354	1.212
		2440.0	1.353	1.212
		2480.0	1.353	1.212

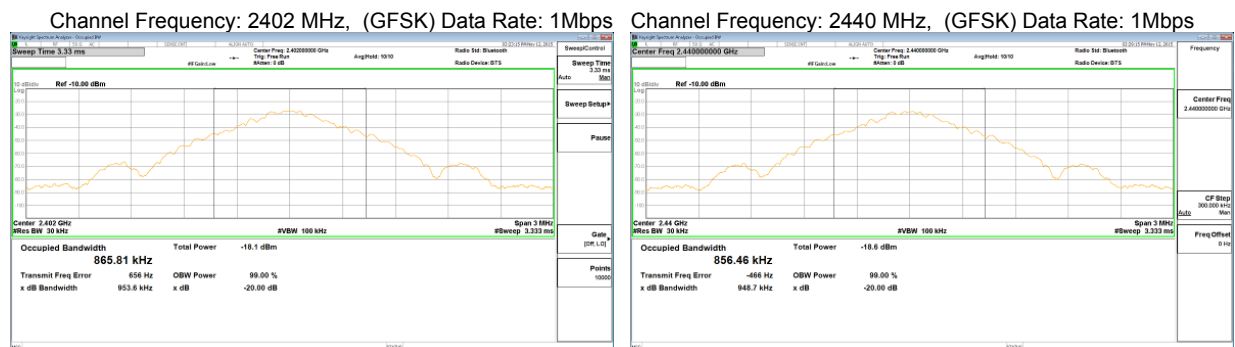

LAB N° 0986

Channel Frequency: 2480 MHz, (GFSK) Data Rate: 1Mbps

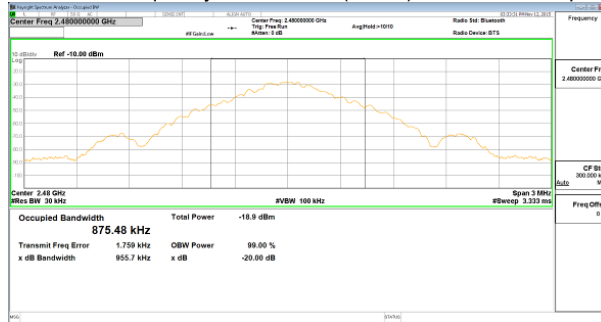

Channel Frequency: 2402 MHz, (8DPSK) Data Rate: 3Mbps

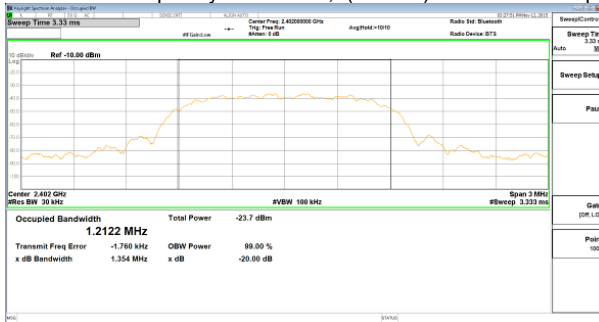

Channel Frequency: 2440 MHz, (8DPSK) Data Rate: 3Mbps

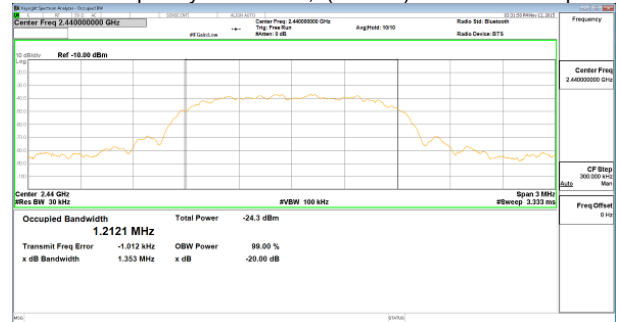

Channel Frequency: 2480 MHz, (8DPSK) Data Rate: 3Mbps

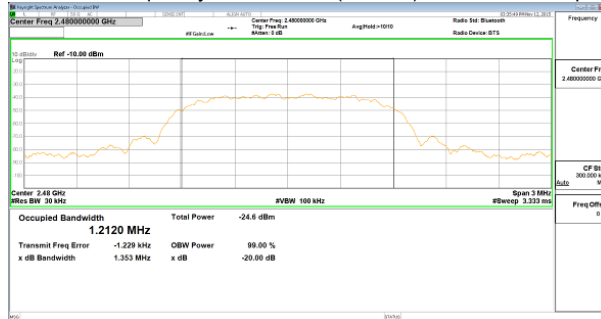

5.0 Band-edge Compliance - Condizioni di prova / Test Conditions

Technician / Tecnico: Loris Fruch		
Table No.	TEST: Band-edge Compliance, Section 15.247(d)	\
Method	ANSI C63.10: 2009-09, par. 7.7.9	\
Parameters required prior to the test	Laboratory Ambient Temperature	18 to 28 °C
	Relative Humidity	20 to 90 %
Parameters recorded during the test	Laboratory Ambient Temperature	20 °C
	Relative Humidity	58 %
Supplementary information:		
<ul style="list-style-type: none"> - Conducted Test, executed at WLAN/Bluetooth antenna output (50ohm, SMA) connected to the Spectrum Analyser through an attenuator (30 dB); - EUT powered at 24Vdc; - EUT Operating Mode: Mode1 (see par. 2.0); - Spectrum analyser settings setup: Detector: Peak, Trace max hold (over last 100 sweeps), RBW: 100 kHz, VBW=300 kHz; - Applicable limit: 20dBc (output power conformity assessed using peak detector); - Test executed with the following BT settings: <ul style="list-style-type: none"> • BR mode with modulation GFSK on channel 0 and 78 with data rate at 1Mbps • EDR mode with modulation 8DPSK on channel 0 and 78 with data rate at 3Mbps • BR mode with modulation GFSK with Hopping ON and data rate at 1Mbps • EDR mode with modulation 8DPSK with Hopping ON and data rate at 1Mbps 		

5.1 Apparecchiature utilizzate / Test Equipment Used – Maximum Peak Conducted Output Power

<i>Apparecchiature usate/Equipment Used</i>	<i>Modello/Model</i>	<i>Costruttore/Manufacturer</i>	<i>Numero di serie/Serial Number</i>	<i>Data calibrazione / Calibration date</i>	<i>Intervallo / Interval</i>
EMI Receiver MXE	N9038A	Agilent Technologies	MY51210230	05/2015	1 year
30dB Attenuator	PE7087-30	Pasternack	EL082315	09/2015	1 year

5.2 Fotografie del setup / Photo of the test setup –Band-edge Compliance

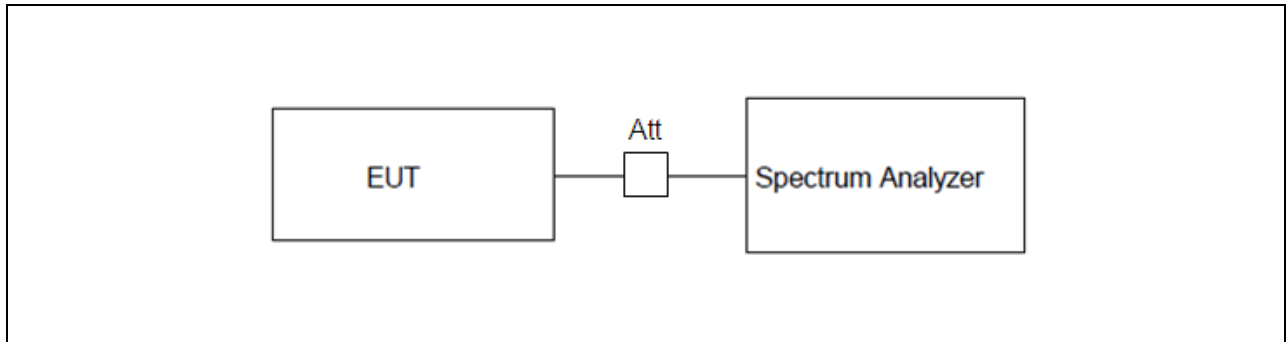

5.3 Risultati / Results - Band-edge Compliance

The result of the test is: **PASS**. See the details in the charts/tables of the following paragraphs (see the worst case in bold text).

5.3.1 Tabelle e grafici dei risultati / Tables and graphical representation of data – Band-edge Compliance

Measures executed on Bluetooth

Hopping OFF

Modulation mode	Data Rate (Mbps)	Max Signal Frequency (MHz)	Max Signal (dBm)	Frequency of Max OOB signal (MHz)	Max OOB Signal (dBm)	Value (dBc)	Limit (dBc)
GFSK	1	2402.1	-25.0	2395.7	-78.37	53.3	20.0
		2479.9	-25.9	2489.5	-77.97	52.0	20.0
8DPSK	3	2402.1	-32.3	2483.5	-84.90	52.6	20.0
		2479.9	-33.3	2486.3	-82.24	49.0	20.0

Channel Frequency: 2402 MHz, (GFSK) Data Rate: 1Mbps

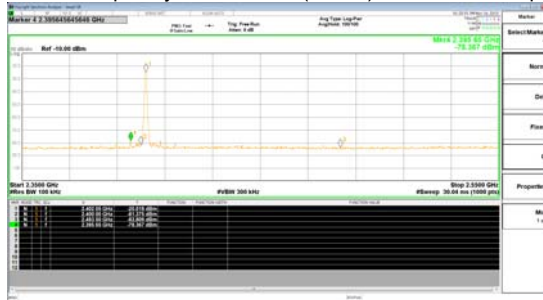

Channel Frequency: 2480 MHz, (GFSK) Data Rate: 1Mbps

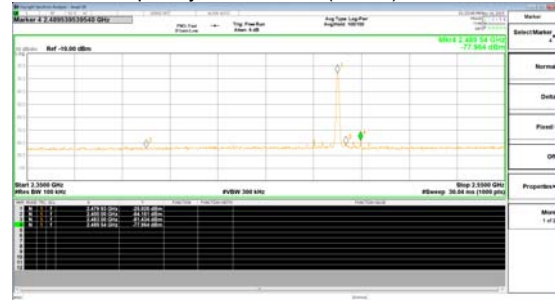

LAB N° 0986

Channel Frequency: 2402 MHz, (8DPSK) Data Rate: 3Mbps

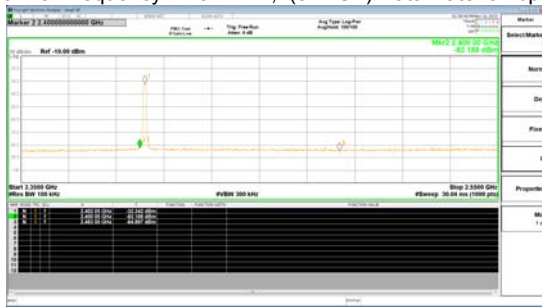

Channel Frequency: 2480 MHz, (8DPSK) Data Rate: 3Mbps

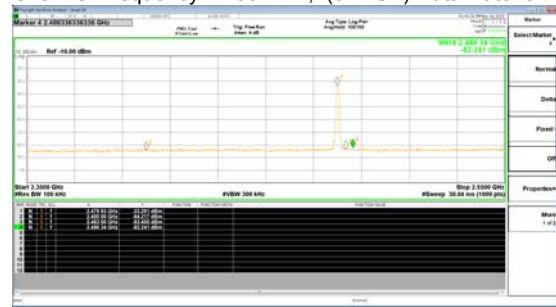

Hopping ON

Modulation mode	Data Rate (Mbps)	Max Signal Frequency (MHz)	Max Signal (dBm)	Frequency of Max OOB signal (MHz)	Max OOB Signal (dBm)	Value (dBc)	Limit (dBc)
GFSK	1	2405.1	-24.9	2395.7	-79.55	54.7	20.0
8DPSK	3	2403.1	-24.8	2484.7	-75.20	50.4	20.0

(GFSK) Data Rate: 1Mbps



(8DPSK) Data Rate: 3Mbps



6.0 Hopping Verifications - Condizioni di prova / Test Conditions

Technician / Tecnico: Loris Fruch		
Table No.	TEST: Number of Hopping Frequency, Section 15.247 (a)(1)(iii) for Bluetooth Hopping Channel Separation, Section 15.247 (a)(1) for Bluetooth Dwell Time, Section 15.247 (a)(1)(iii) for Bluetooth	\
Method	/	\
Parameters required prior to the test	Laboratory Ambient Temperature	18 to 28 °C
	Relative Humidity	20 to 90 %
Parameters recorded during the test	Laboratory Ambient Temperature	21 °C
	Relative Humidity	50 %
Supplementary information:		
<ul style="list-style-type: none"> - Conducted Test, executed at WLAN/Bluetooth antenna output (50ohm, SMA) connected to the Spectrum Analyser through an attenuator (30 dB); - EUT powered at 24Vdc; - EUT Operating Mode: Mode1(see par. 2.0); - Spectrum analyser settings setup: Detector: Peak, Trace: max hold (over last 100 sweeps), RBW: 100 kHz, VBW=300 kHz; - Test executed with the following BT settings: <ul style="list-style-type: none"> • BR mode with modulation GFSK on channel 0, 38 and 78 with data rate at 1Mbps • EDR mode with modulation 8DPSK on channel 0, 38 and 78 with data rate at 3Mbps 		

6.1 Apparecchiature utilizzate / Test Equipment Used – Hopping Verifications

<i>Apparecchiature usate/Equipment Used</i>	<i>Modello/Model</i>	<i>Costruttore/Manufacturer</i>	<i>Numero di serie/Serial Number</i>	<i>Data calibrazione / Calibration date</i>	<i>Intervallo / Interval</i>
EMI Receiver MXE	N9038A	Agilent Technologies	MY51210230	05/2015	1 year
30dB Attenuator	PE7087-30	Pasternack	EL082315	09/2015	1 year

6.2 Fotografie del setup / Photo of the test setup –Hopping Verifications

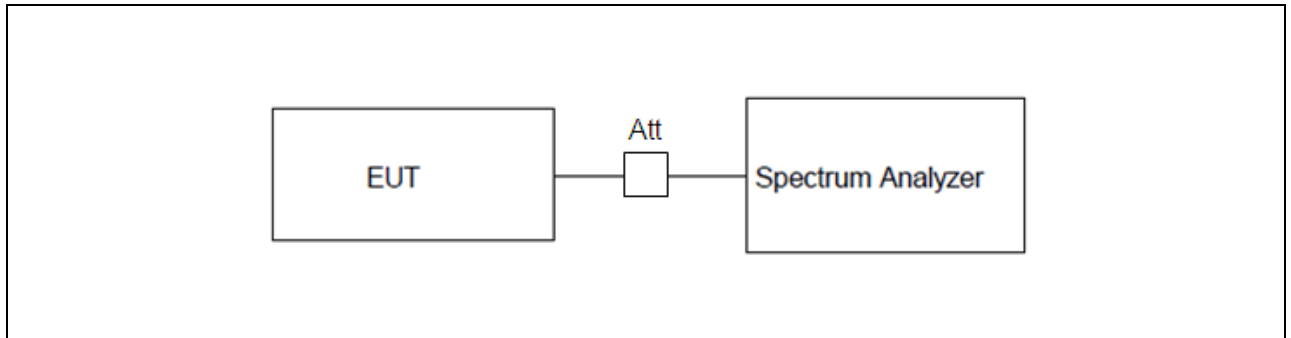

6.3 Risultati / Results – Hopping Verifications

The result of the test is: **PASS**. See the details in the charts/tables of the following paragraphs.

6.3.1 Tabelle e grafici dei risultati / Tables and graphical representation of data – Hopping Verifications

Number of Hopping Frequency

GFSK, Data Rate: 1Mbps



8DPSK, Data Rate: 3Mbps

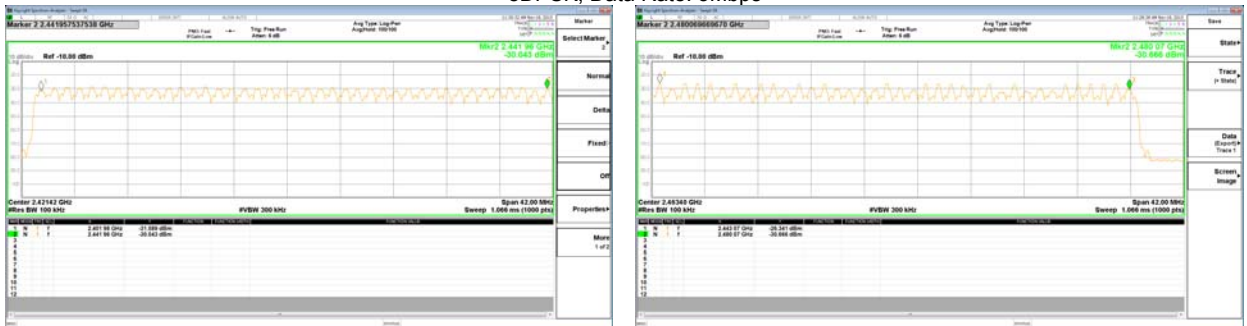

Section 15.247 (a)(1)(iii) Frequency hopping systems in the 2400-2483.5 MHz band shall use at least 15 channels, thus the result of the test is: **PASS**.

Channel Separation

Modulation Mode	Frequency (MHz)	Measured Channel Separation (MHz)	Measured 20dB Bandwidth (*) (MHz)	Applicable Minimum Limit (MHz)
GFSK	2402	1.003	0.954	0.636
GFSK	2441	1.003	0.949	0.632
GFSK	2480	1.003	0.956	0.637
8DPSK	2402	1.003	1.354	0.903
8DPSK	2441	1.003	1.353	0.902
8DPSK	2480	1.003	1.353	0.902

(*) Measures were collected at paragraph 5.3.1

Section 15.247 (a) (1) Frequency hopping systems operating in the 2400-2483.5 MHz band may have hopping channel carrier frequencies that are separated by 25 kHz or two-thirds of the 20 dB bandwidth of the hopping channel, whichever is greater, provided the systems operate with an output power no greater than 125 mW., thus the result of the test is: **PASS**.

Channel Separation Measure: Worst Case Plot

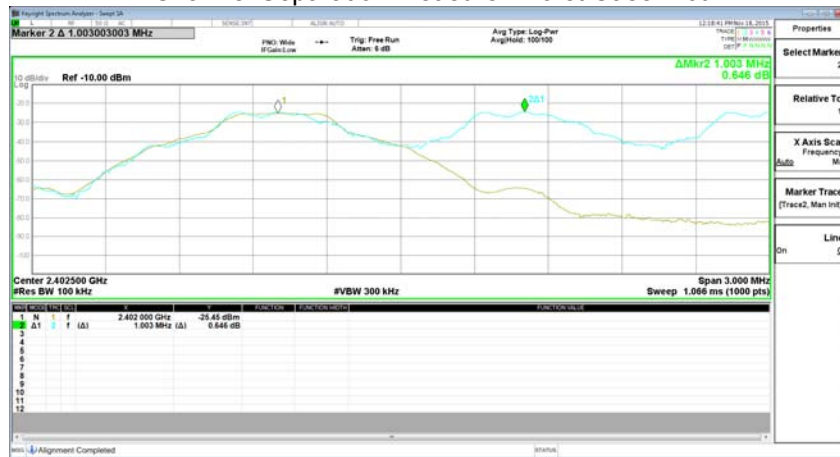

Dwell Time

Modulation Mode	Frequency (MHz)	Length of Transmission Time (msec)	Number of Transmissions in a 31.6s interval (*) (79Hopp Ch*0.4)	Result (s)	Limit (s)
GFSK-DH1	2402	0.425	320	0.136	0.4
GFSK-DH3	2402	1.684	160	0.269	0.4
GFSK-DH5	2402	2.933	106.6	0.313	0.4
8DPSK-3DH1	2402	0.430	320	0.138	0.4
8DPSK-3DH3	2402	1.689	160	0.270	0.4
8DPSK-3DH5	2402	3.058	106.6	0.326	0.4

(*) The DH1 packet can cover a single time slot. A maximum length packet has duration of 1 time slot. The hopping rate is 1600 hops/second so the maximum dwell time is 1/1600 seconds, or 0.625ms. DH1 Packet permit maximum $1600/79/2=10.12$ hops per second in each channel (1 time slot Tx, 1 time slot Rx). So, the dwell time is the time duration of the pulse time $10.12 \times 31.6=320$ within 31.6 seconds.

The DH3 packet can cover up to 3 time slots. A maximum length packet has duration of 3 time slot. The hopping rate is 1600 hops/second so the maximum dwell time is 3/1600 seconds, or 1.875ms. DH3 Packet permit maximum $1600/79/4=5.06$ hops per second in each channel (3 time slot Tx, 1 time slot Rx). So, the dwell time is the time duration of the pulse time $5.06 \times 31.6=160$ within 31.6 seconds.

The DH5 packet can cover up to 5 time slots. Operate DH5 at maximum dwell time and maximum duty cycle. A maximum length packet has duration of 5 time slot. The hopping rate is 1600 hops/second so the maximum dwell time is 5/1600 seconds, or 3.125ms. DH5 Packet permit maximum $1600/79/6=3.37$ hops per second in each channel (5 time slot Tx, 1 time slot Rx). So, the dwell time is the time duration of the pulse time $3.37 \times 31.6=106.6$ within 31.6 seconds.

GFSK

DH1



DH3

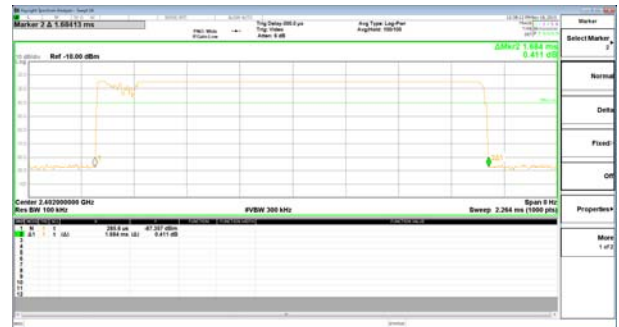

DH5

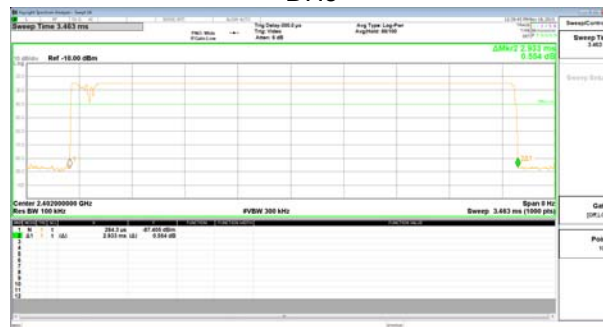

LAB N° 0986

8DPSK

3DH1

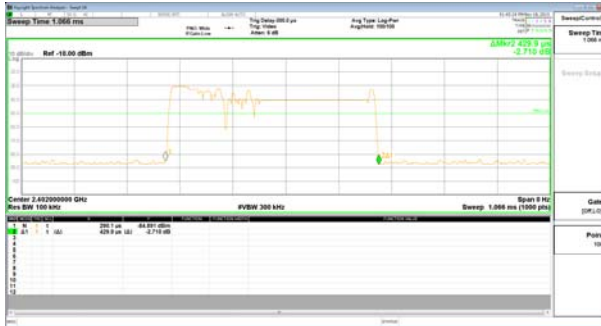

3DH3

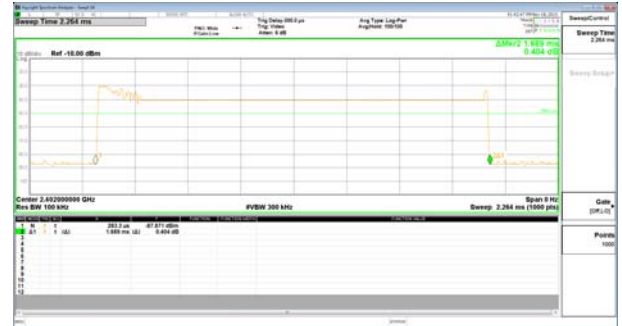

3DH5

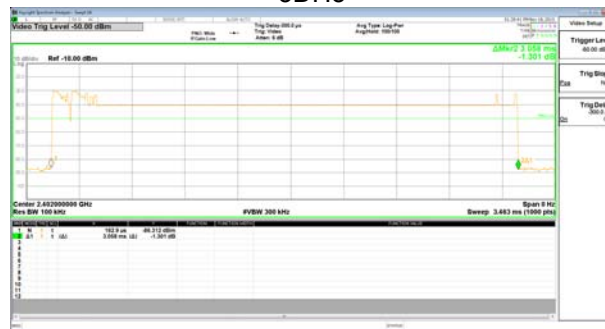

7.0 Conducted Spurious Emissions -Condizioni di prova / Test Conditions

Technician / Tecnico: Loris Fruch		
Table No.	TEST: Conducted Spurious Emissions, Section 15.247 (d)	\
Method	ANSI 63.10 – 2009 par.7.7.10	\
Parameters required prior to the test	Laboratory Ambient Temperature	18 to 28 °C
	Relative Humidity	20 to 90 %
Parameters recorded during the test	Laboratory Ambient Temperature	21°C
	Relative Humidity	56 %
Supplementary information:		
<ul style="list-style-type: none"> - Conducted Test, executed at WLAN/Bluetooth antenna output (50ohm, SMA) connected to the Spectrum Analyser through an attenuator (30 dB); - Frequency range of the measurements: up to 26GHz. - EUT powered at 24Vdc; - EUT Operating Mode: Mode1(see par. 2.0); - Spectrum analyser setting: Detector= Peak, Trace= max hold (over last 20 sweeps), RBW= 100 kHz, VBW=300 kHz, - Test aim is to verify that in any 100 kHz bandwidth outside the frequency band in which the digitally modulated intentional radiator is operating, the radio frequency power that is produced by the intentional radiator is at least 20 dB below that in the 100 kHz bandwidth within the band that contains the highest level of the desired power. - Test executed with the following BT settings: <ul style="list-style-type: none"> • BR mode with modulation GFSK on channel 0 and 78 with data rate at 1Mbps • EDR mode with modulation 8DPSK on channel 0 and 78 with data rate at 3Mbps • BR mode with modulation GFSK with Hopping ON and data rate at 1Mbps • EDR mode with modulation 8DPSK with Hopping ON and data rate at 1Mbps 		

7.1 Apparecchiature utilizzate / Test Equipment Used – Maximum Peak Conducted Output Power

<i>Apparecchiature usate/Equipment Used</i>	<i>Modello/Model</i>	<i>Costruttore/Manufacturer</i>	<i>Numero di serie/Serial Number</i>	<i>Data calibrazione / Calibration date</i>	<i>Intervallo / Interval</i>
EMI Receiver MXE	N9038A	Agilent Technologies	MY51210230	05/2015	1 year
30dB Attenuator	PE7087-30	Pasternack	EL082315	09/2015	1 year

7.2 Fotografie del setup / *Photo of the test setup* –Conducted Spurious Emissions

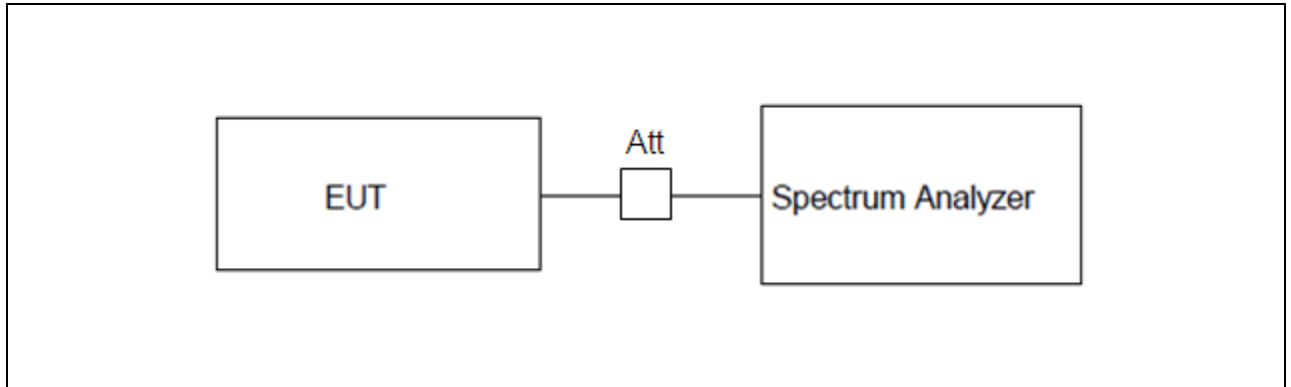

7.3 Risultati / *Results* - Conducted Spurious Emissions

The amplitude of spurious emissions is lower than 20 dBc, thus the result of the test is: **PASS**. See the details in the charts of the following paragraphs.

7.3.1 Grafici dei risultati / Graphical representation data – Conducted Spurious Emissions

Note: all the traces reported in this section have been obtained with detector Peak, max hold (over last 20 sweeps); RBW: 100kHz, VBW.300kHz

Measures executed on Bluetooth

Hopping OFF

Channel Frequency: 2402 MHz, (GFSK) Data Rate: 1Mbps

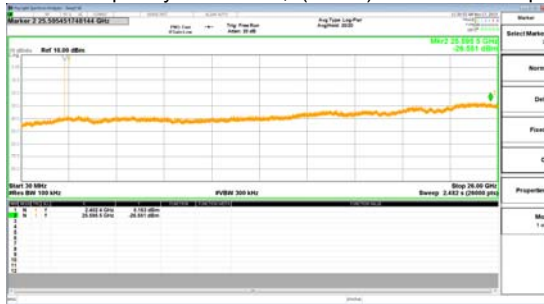

Channel Frequency: 2480 MHz, (GFSK) Data Rate: 1Mbps

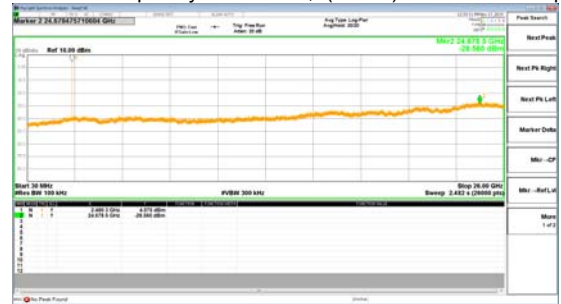

Channel Frequency: 2402 MHz, (8DPSK) Data Rate: 3Mbps

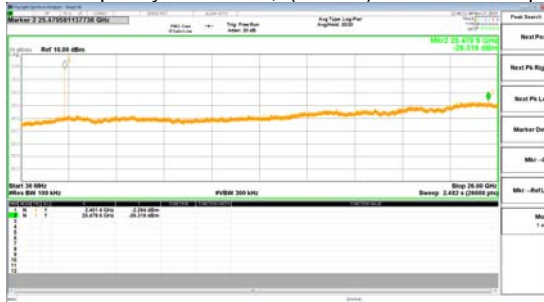

Channel Frequency: 2480 MHz, (8DPSK) Data Rate: 3Mbps

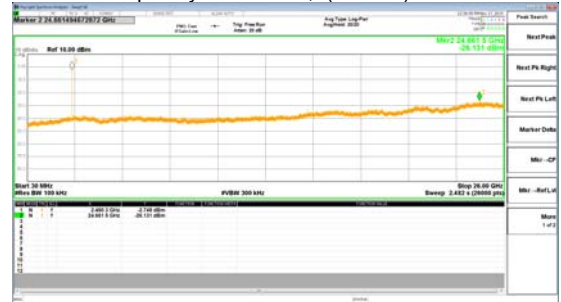

Hopping ON

GFSK Modulation

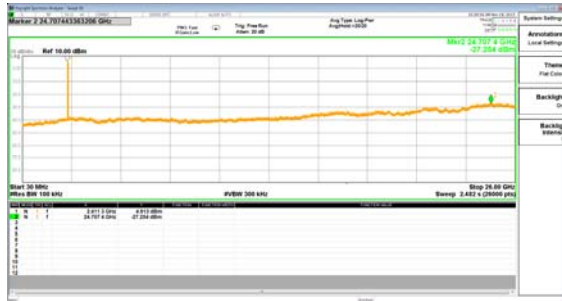

8DPSK Modulation

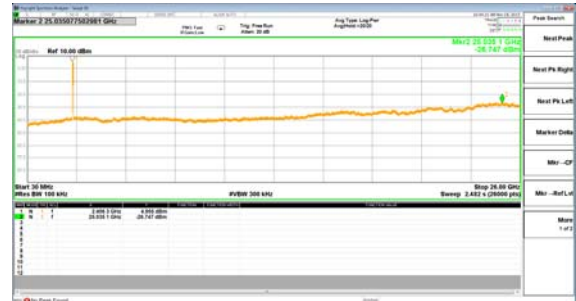

Allegato 2 / Annex 2: Incertezza / Uncertainty

A.2.1 Radio test

Conducted output power	: ± 2.1 dB
Conducted adjacent channel power	: ± 1.6 dB
Conducted Bandwidth	: ± 9.1 KHz (Span=40M, RBW=430KHz, 1000pti) : ± 7.7 KHz (Span=40M, RBW=100KHz, 1000pti) : ± 10.6 KHz (Span=80M, RBW=100KHz, 1000pti)
Conducted spurious emission	: ± 3.7 dB