

FCC and ISED Test Report for Parts 15.247, 15.209, RSS-GEN and RSS-247 (DTS)

Product name : WRMB
Applicant : SALTO Systems, S.L.
FCC ID : UKCWRMB
ISED ID : 10088A-WRMB

Test report No. : 160400933 006 Ver 2.00

Laboratory information

Accreditation

Telefication is designated by the FCC as an Accredited Test Firm for compliance testing of equipment subject to Certification under Parts 15 & 18. The Designation number is: NL0001

The Industry Canada registration number for the 3 meter test chamber of Telefication is: 4173A-1.

Documentation

Telefication complies with the accreditation criteria for test laboratories as laid down in ISO/IEC 17025:2005. The accreditation covers the quality system of the laboratory as well as the specific activities as described in the authorized annex bearing the accreditation number L021 and is granted on 30 November 1990 by the Dutch Council For Accreditation (RvA: Raad voor Accreditatie).

The test report must always be reproduced in full; reproduction of an excerpt only is subject to written approval of the testing laboratory. The documentation of the testing performed on the tested devices is archived for 10 years at Telefication Netherlands

Testing Location

Test Site	Telefication BV
Test Site location	Edisonstraat 12a 6902 PK Zevenaar The Netherlands Tel. +31316583180 Fax. +31316583189
Test Site FCC	NL0001

Revision History

Version	Date	Remarks	By
V0.50	1-5-2017	First draft	PS
V1.00	2-5-2017	Initial release	PS
V1.50	22-6-2017	ISED RSS-GEN and RSS-247 requirements included; Antenna gain added in section 1.4	PS
V2.00	26-6-2017	Second release	PS

Table of Contents

Revision History	2
Summary of Test results.....	5
1 General Description.....	6
1.1 Applicant.....	6
1.2 Manufacturer	6
1.3 Tested Equipment Under Test (EUT)	6
1.4 Product specifications of Equipment under test	7
1.5 Modification of the Equipment Under Test (EUT).....	7
1.6 Observations and remarks.....	7
1.7 Environmental conditions.....	7
1.8 Measurement Standards	7
1.9 Applicable Standards	7
1.10 Conclusions.....	8
2 Test configuration of the Equipment Under Test	9
2.1 Test mode	9
2.2 Tested channels and Data rates	9
2.3 Test setups.....	10
2.4 Equipment used in the test configuration.....	11
2.5 Sample calculations	11
3 Test results	12
3.1 6dB bandwidth Measurement.....	12
3.1.1 Limit.....	12
3.1.2 Measurement instruments	12
3.1.3 Test setup.....	12
3.1.4 Test procedure	12
3.1.5 Test Results of the 6 dB bandwidth Measurement.....	12
3.1.6 Plots of the 6 dB bandwidth Measurement	13
3.2 99 % occupied bandwidth	15
3.2.1 Limit.....	15
3.2.2 Measurement instruments	15
3.2.3 Test setup.....	15
3.2.4 Test procedure	15
3.2.5 Test results of the 99% Occupied Bandwidth Measurement.....	15
3.2.6 Plot of the 99% Occupied Bandwidth Measurement	15
3.3 Output Power Measurement	16
3.3.1 Limit.....	16
3.3.2 Measurement instruments	16

3.3.3	Test setup.....	16
3.3.4	Test procedure	16
3.3.5	Test results of Output Power Measurement.....	16
3.3.6	Plots of Peak Output Power Measurement	17
3.4	Power Spectral Density.....	19
3.4.1	Limit.....	19
3.4.2	Measurement instruments	19
3.4.3	Test setup.....	19
3.4.4	Test procedure	19
3.4.5	Test results of Power Spectral Density Measurement	19
3.4.6	Plots of the Power Spectral Density Measurements.....	20
3.5	Radiated Spurious Emissions Measurement	22
3.5.1	Limit.....	22
3.5.2	Measurement instruments	22
3.5.3	Test setup.....	22
3.5.4	Test procedure	22
3.5.5	Notes	22
3.5.6	Plots of the Radiated Spurious Emissions Measurement.....	23
3.5.7	Measurement Uncertainty.....	27
3.6	Conducted Spurious Emissions Measurement	28
3.6.1	Limit.....	28
3.6.2	Measurement instruments	28
3.6.3	Test setup.....	28
3.6.4	Test procedure	28
3.6.5	Plots of the Conducted Spurious Emissions Measurement	28
3.6.6	Measurement Uncertainty.....	28
3.7	Band edge emissions in the authorized band.....	31
3.7.1	Limit.....	31
3.7.2	Measurement instruments	31
3.7.3	Test setup.....	31
3.7.4	Test procedure	31
3.7.5	Test results of band edge measurements	31
3.7.6	Measurement Uncertainty.....	31
3.7.7	Plots of the band edge measurements	32

Summary of Test results

FCC section	ISED RSS-247 section	ISED RSS-GEN section	Description	Section in report	Verdict
15.247(a)	5.2 a)	--	6 dB bandwidth	3.1	Pass
--	--	6.6	99 % occupied bandwidth	3.2	--
15.247(b)(c)	5.4 d)	--	RF output power	3.3	Pass
15.247(e)	5.2 b)	--	Power spectral density	3.4	Pass
15.209 (a)	--	6.13	Radiated spurious emissions	3.5	Pass
15.247 (d)	5.5	--	Conducted spurious emissions	3.6	Pass
15.247 (d)	5.5	--	Band edge emissions in the authorized band	3.7	Pass

1 General Description

1.1 Applicant

Client name:	Salto systems, S.L.
Address	C/Arkotz 9 Pol. Lanbarre, Oiartzun
Zip code:	20180
Telephone:	+34 943344550
E-mail:	j.gutierrez@saltosystems.com
Contact name:	J. Gutierrez

1.2 Manufacturer

Manufacturer name:	Salto systems, S.L.
Address:	C/Arkotz 9 Pol. Lanbarre, Oiartzun
Zip code:	20180
Telephone:	+34 943344550
E-mail:	j.gutierrez@saltosystems.com
Contact name:	J. Gutierrez

1.3 Tested Equipment Under Test (EUT)

Product name:	WRMB
Brand name:	SALTO
Product type:	BLE capable wall RFID card reader
FCC ID:	UKCWRMB
Model(s):	WRMB
Software version:	Special firmware for testing
Hardware version:	--
Date of receipt	18-05-2016
Tests started:	08-06-2016
Testing ended:	09-06-2016

1.4 Product specifications of Equipment under test

Transceiver frequency range (MHz):	2402 – 2480 MHz
Maximum output power to antenna:	0 dBm
Antenna type :	PIFA
Antenna gain (dBi):	0 (approx.)
Type of modulation:	GFSK
Channel Spacing (MHz):	2
Emission designator Bluetooth BLE:	700KG1D

1.5 Modification of the Equipment Under Test (EUT)

None.

1.6 Observations and remarks

None.

1.7 Environmental conditions

Test date	9-6-2016
Ambient temperature	25.6 °C
Humidity	45.1 % RH

1.8 Measurement Standards

- FCC KDB Publication No. 558074 D01DTS Meas. Guidance V03r05;
- ANSI C63.10:2013;
- RSS-GEN issue 4;
- RSS-247 issue 2

1.9 Applicable Standards

According to the specifications of the manufacturer, the EUT must comply with the requirements of the following standards:

- FCC Part 15 Subpart C §15.247, §15.209

1.10 Conclusions

The sample of the product showed NO NON-COMPLIANCES to the specifications stated in paragraph 1.9 of this report.

The results of the test as stated in this report, are exclusively applicable to the product items as identified in this report. Telefication accepts no responsibility for any properties of product items in this test report, which are not supported by the tests as specified in paragraph 1.9 "*Applicable standards*".

All tests are performed by:

Name : ing P.A. Suringa

Review of test methods and report by:

Name : ing R. van Barneveld

The above conclusions have been verified by the following signatory:

Date : 26-6-2017

Name : ing K.A. Roes

Function : Coordinator Radio Laboratory

Signature :



2 Test configuration of the Equipment Under Test

2.1 Test mode

The applicant provided test mode firmware for the EUT, in which it was possible to configure the EUT into different test channels.

2.2 Tested channels and Data rates

Technology	Channels	Packet type	Data rate	Frequency (MHz)
Bluetooth Low Energy	37	--	1 Mbps	2402
	17	--	1 Mbps	2440
	39	--	1 Mbps	2480

2.3 Test setups

Radiated emissions test setup 30 MHz - 1 GHz

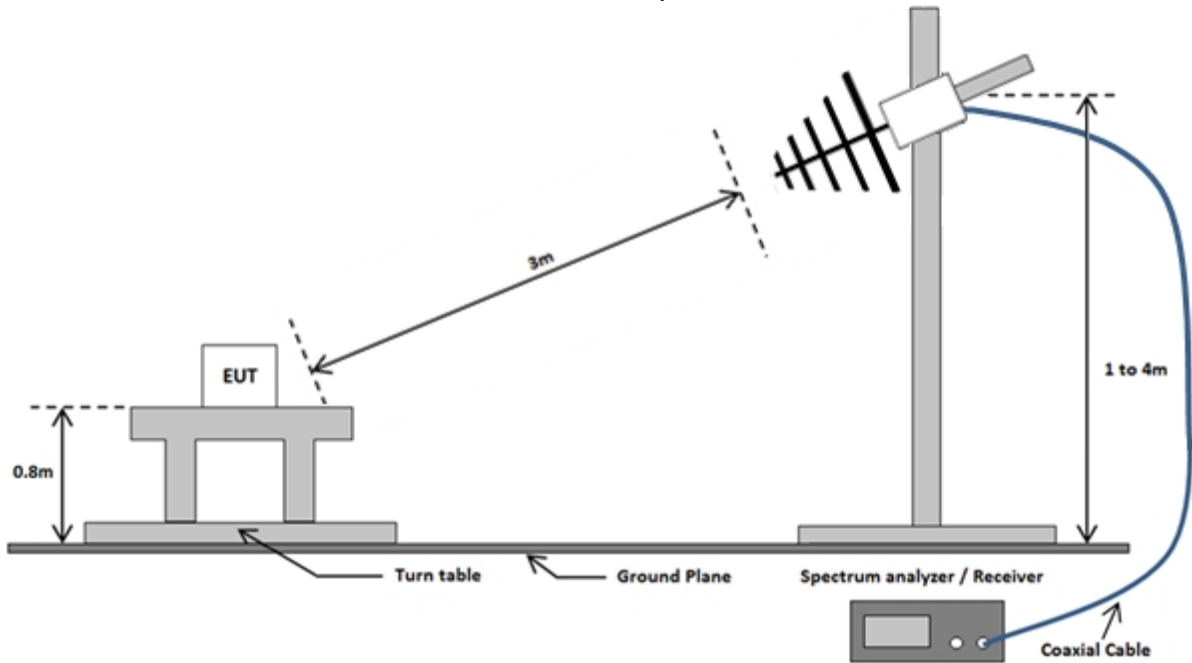

Radiated emissions test setup above 1 GHz

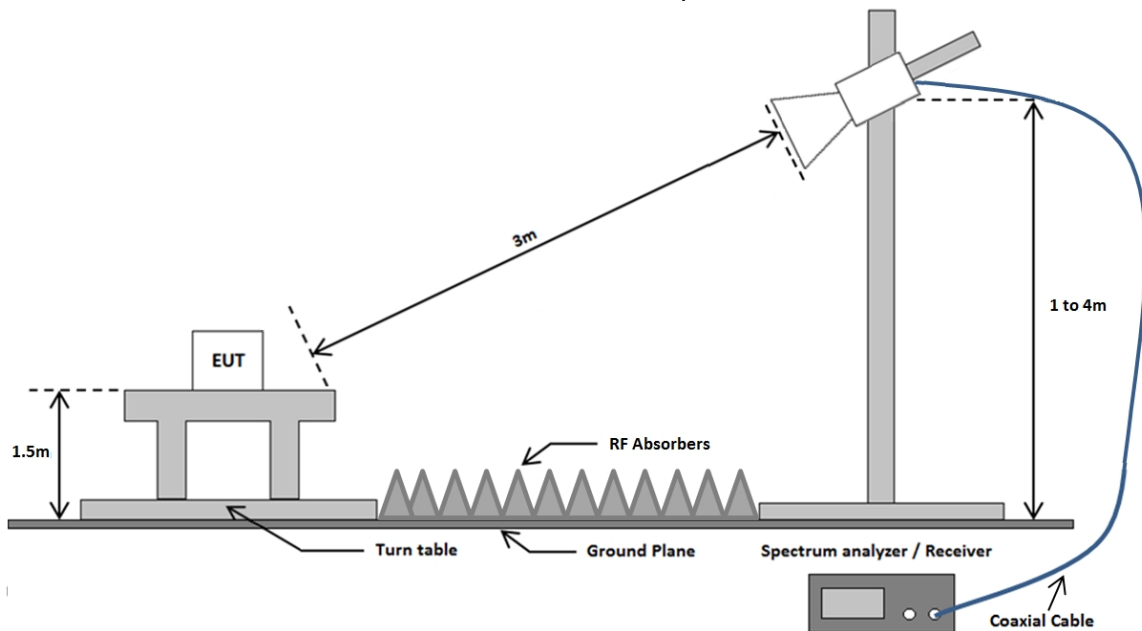

Conducted emissions 0.03 – 26 GHz



2.4 Equipment used in the test configuration

Description	Manufacturer	Model	ID	Used at Par.
Signal Generator	Hewlett Packard	83650B	TE00487	3.3, 3.4, 3.6
Spectrum Analyzer	Rohde & Schwarz	FSV	TE01269	3.1, 3.3, 3.4, 3.6, 3.7
Spectrum Analyzer	Rohde & Schwarz	FSP40	TE11125	3.2, 3.5
Spectrum Analyzer	Rohde & Schwarz	ESR7	TE01220	3.5
10 MHz distribution Amplifier	Stanford Research Systems	FS735/1	TE01278	3.1, 3.3, 3.4, 3.6, 3.7
USB to GPIB adapter	National Instruments	GPIB-USB-HS+	TE01283	3.1, 3.3, 3.4, 3.6, 3.7
Biconilog Antenna	Chase	CBL6112A	TE00967	3.5
Horn Antenna	EMCO The Electro – Mechanics Co	3115	TE00531	3.2, 3.5
SAC Chamber	Comtest Engineering BV	-	TE00861	3.5
Measurement software	DARE!!	RadiMation® Ver. 2016.2.8	--	3.5
Measurement software	Rebase systems	2.0	--	3.1, 3.3, 3.4, 3.6, 3.7

2.5 Sample calculations

Field Strength Calculation using example values:

Frequency (GHz)	Polarization	Height(m)	Peak (dB μ V/m)
4.959	Vertical	3	51.8

The following relation applies:

$$E \text{ (dB}\mu\text{V/m)} = U \text{ (dB}\mu\text{V)} + AF \text{ (dB/m)} - G \text{ (dB)} + CL \text{ (dB)}$$

Where:

E = Electric field strength

U = Measuring receiver voltage

AF = Antenna factor

G = Gain of the pre-amplifier

CL = Cable loss

$$(51.8 = 52.49 + 33.1 - 38.19 + 4.4)$$

3 Test results

3.1 6dB bandwidth Measurement

3.1.1 Limit

The minimum 6 dB Bandwidth shall be at least 500 kHz.

3.1.2 Measurement instruments

The measurement instruments are listed in chapter 2.4 of this report.

3.1.3 Test setup

The test setup is as shown in chapter 2.3 of this report.

3.1.4 Test procedure

The testing follows FCC KDB Publication No. 558074 D01 DTS Meas. Guidance v03r05.

3.1.5 Test Results of the 6 dB bandwidth Measurement

Technology Std.	Channel	Frequency (MHz)	Data rate	6dB bandwidth (kHz)
Bluetooth Low Energy	37	2402	1 Mbps	674.89
	17	2440	1 Mbps	657.09
	39	2480	1 Mbps	675.33
Uncertainty	± 58 kHz			

3.1.6 Plots of the 6 dB bandwidth Measurement

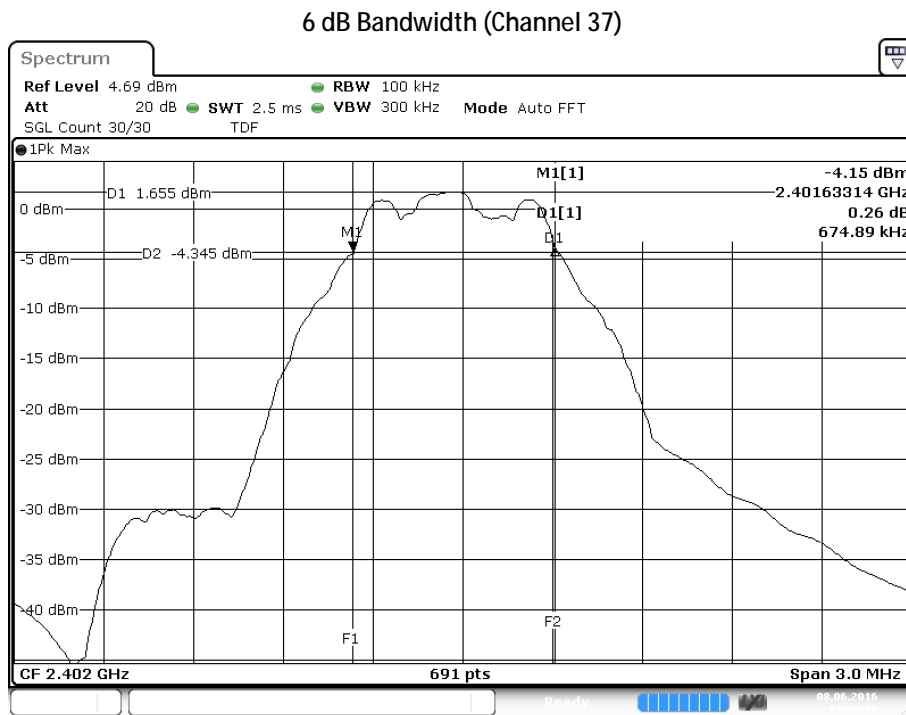

Ble, channel: 0 : 6 dB BW Measurement
 Date: 8 JUN.2016 13:42:17

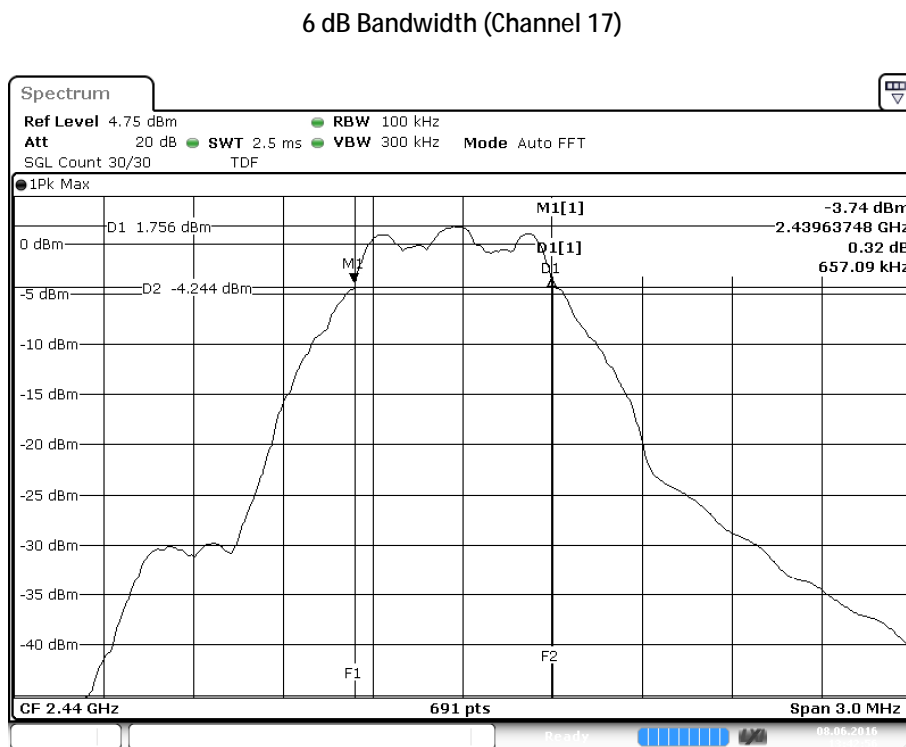

Ble, channel: 19 : 6 dB BW Measurement
 Date: 8 JUN.2016 13:42:56

6 dB Bandwidth (Channel 39)

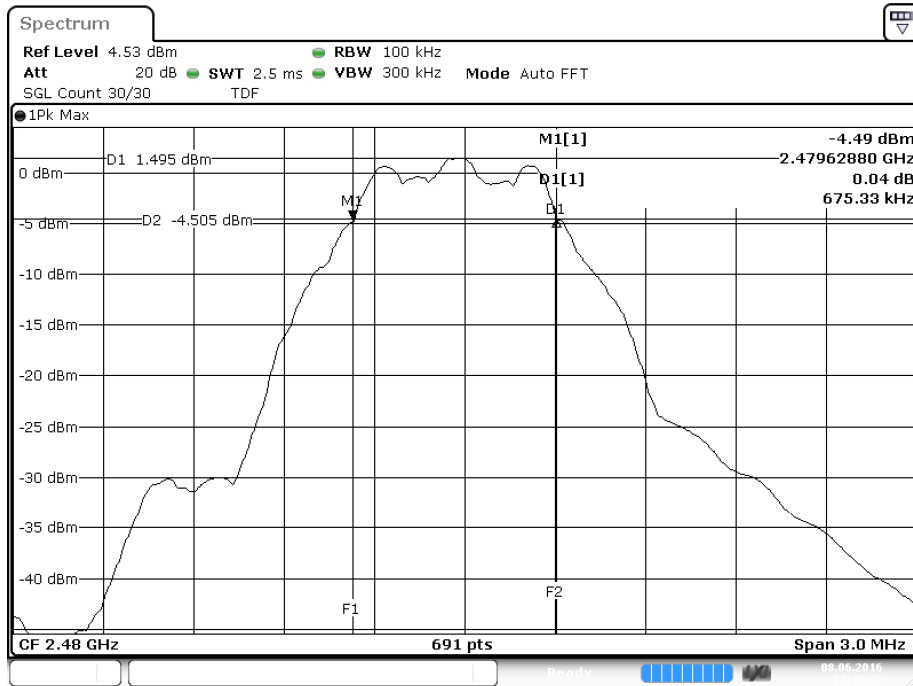

Ble, channel: 39 : 6 dB BW Measurement
 Date: 8.JUN.2016 13:43:34

3.2 99 % occupied bandwidth

3.2.1 Limit

According to RSS-Gen 6.6

3.2.2 Measurement instruments

The measurement instruments are listed in chapter 2.3 of this report.

3.2.3 Test setup

The test setup is as shown in chapter 2.2 of this report.

3.2.4 Test procedure

- 1 Set the centre frequency to the nominal EUT channel centre frequency.
- 2 Set span = 1.5 times to 0.5 times the Occupied Bandwidth.
- 3 Set VBW $\geq 3 \times$ RBW.
- 4 Video averaging is not permitted. Where practical detection and single sweep mode shall be used. Otherwise, peak detection and max hold mode(until the trace stabilizes) shall be used.

3.2.5 Test results of the 99% Occupied Bandwidth Measurement

Technology Std.	Frequency (MHz)	99% Occupied Bandwidth (kHz)
BLE	2402	1010
Uncertainty		± 65 kHz

3.2.6 Plot of the 99% Occupied Bandwidth Measurement

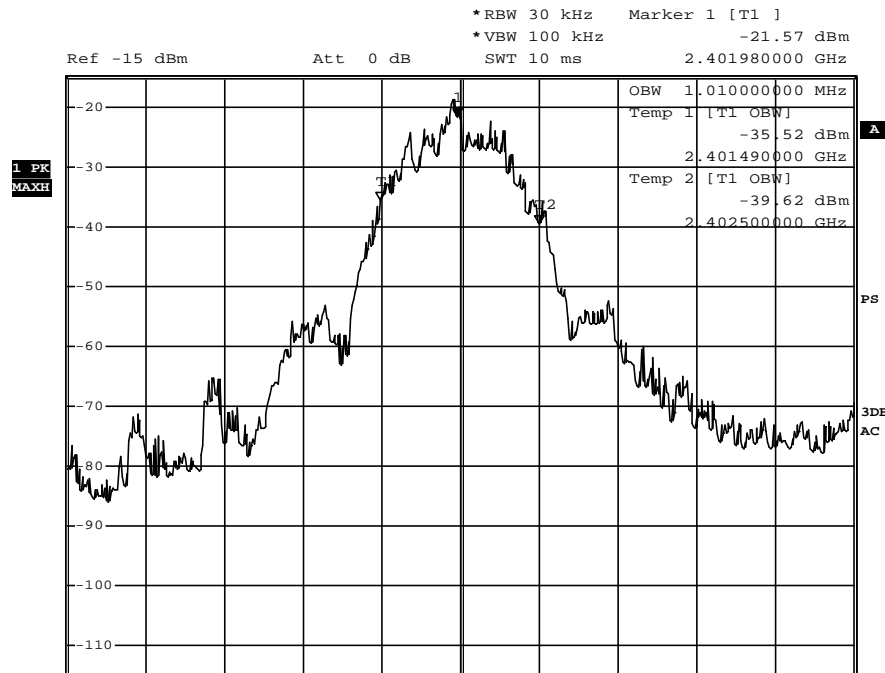

3.3 Output Power Measurement

3.3.1 Limit

For systems using digital modulation in the 2400-2483.5 MHz band, the limit for the peak output power is 30 dBm. If transmitting antenna of directional gain greater than 6 dBi is used, the peak output power from the intentional radiator shall be reduced below the above stated value by the amount in dB that the directional gain of the antenna exceeds 6 dBi. In case of point to point operation, the limit has to be reduced by 1 dB for every 3 dB that the directional gain of the antenna exceeds 6 dBi.

3.3.2 Measurement instruments

The measurement instruments are listed in chapter 2.4 of this report.

3.3.3 Test setup

The test setup is as shown in chapter 2.3 of this report.

3.3.4 Test procedure

The testing follows FCC KDB Publication No. 558074 D01 DTS Meas. Guidance v03r05.

3.3.5 Test results of Output Power Measurement

Technology Std.	Peak method			
	Channels	Frequency (MHz)	Data rate	Peak output power (dBm)
Bluetooth Low Energy	37	2402	1 Mbps	1.79
	17	2440	1 Mbps	1.78
	39	2480	1 Mbps	1.57
Uncertainty	± 0.9 dB			

3.3.6 Plots of Peak Output Power Measurement

Peak Output Power (Channel 37)

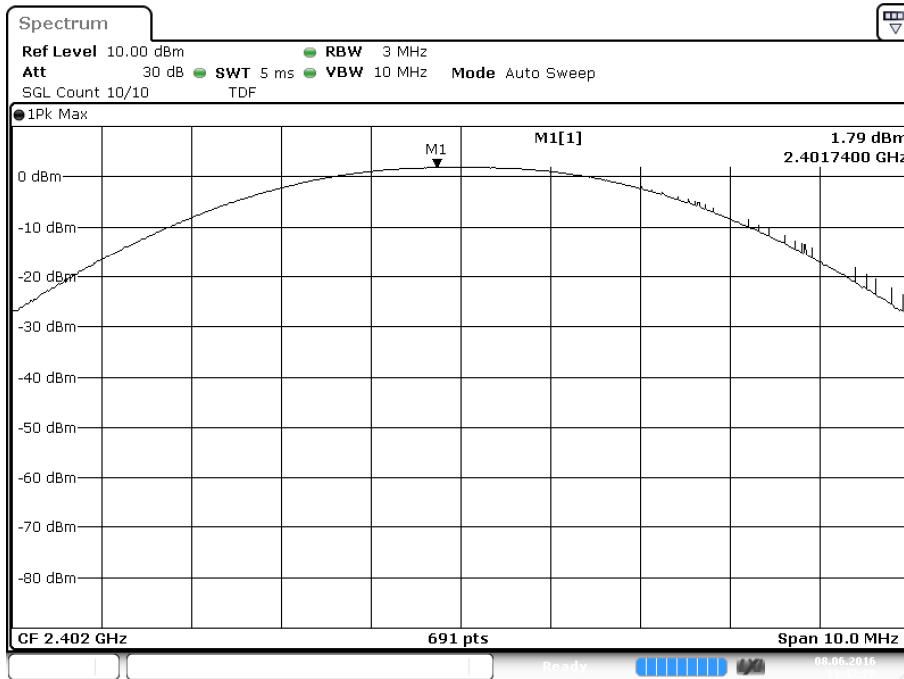

Ble Channel: 0 : Measure DUT output power
 Date: 8 JUN.2016 13:42:29

Peak Output Power (Channel 17)

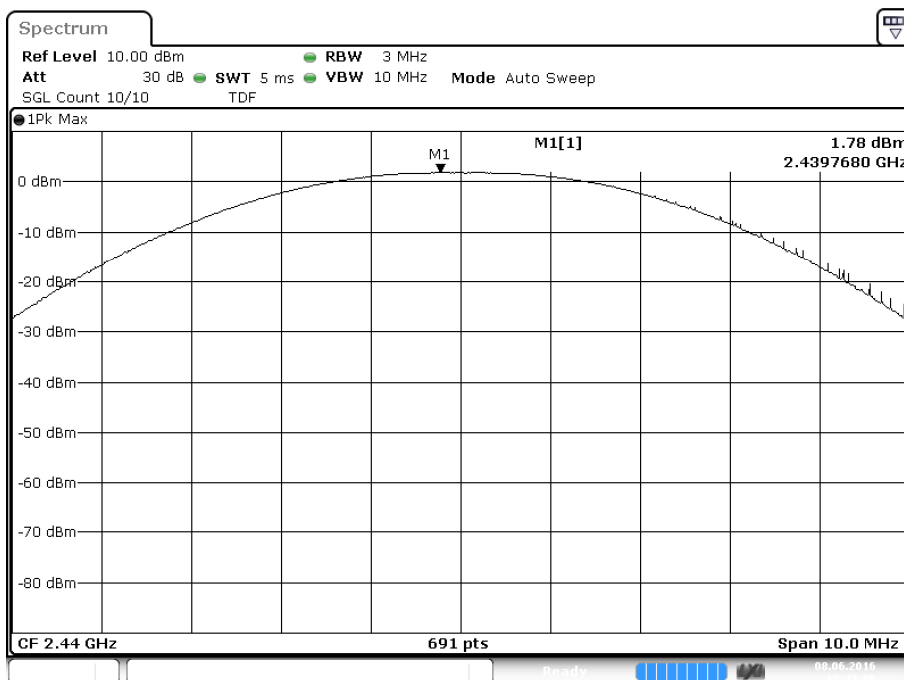

Ble Channel: 19 : Measure DUT output power
 Date: 8 JUN.2016 13:43:08

Peak Output Power (Channel 39)

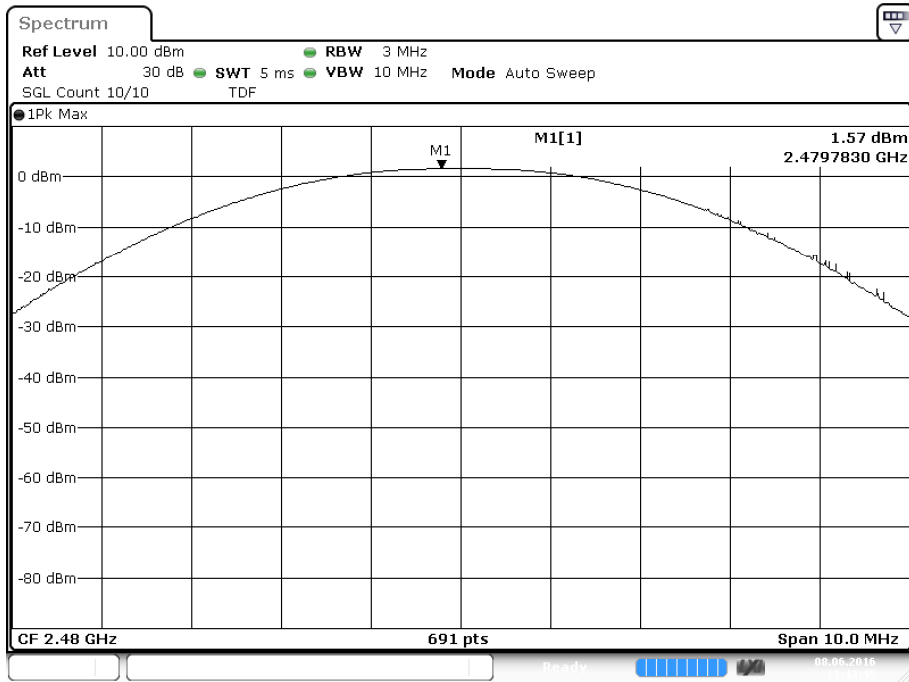

Ble Channel: 39 : Measure DUT output power

Date: 8 JUN 2016 13:43:45

3.4 Power Spectral Density

3.4.1 Limit

The peak power spectral density shall not be greater than 8 dBm in any 3 kHz band at any time interval of continuous transmission.

3.4.2 Measurement instruments

The measurement instruments are listed in chapter 2.4 of this report.

3.4.3 Test setup

The test setup is as shown in chapter 2.3 of this report.

3.4.4 Test procedure

The testing follows FCC KDB Publication No. 558074 D01 DTS Meas. Guidance v03r05.

3.4.5 Test results of Power Spectral Density Measurement

Technology Std.	Channels	Frequency (MHz)	Data rate	PSD/3 kHz (dBm)
Bluetooth Low Energy	37	2402	1 Mbps	-12.22
	17	2440	1 Mbps	-11.91
	39	2480	1 Mbps	-10.70
Uncertainty	±0.63 dB			

3.4.6 Plots of the Power Spectral Density Measurements

Power Spectral Density 3 kHz (channel 37)

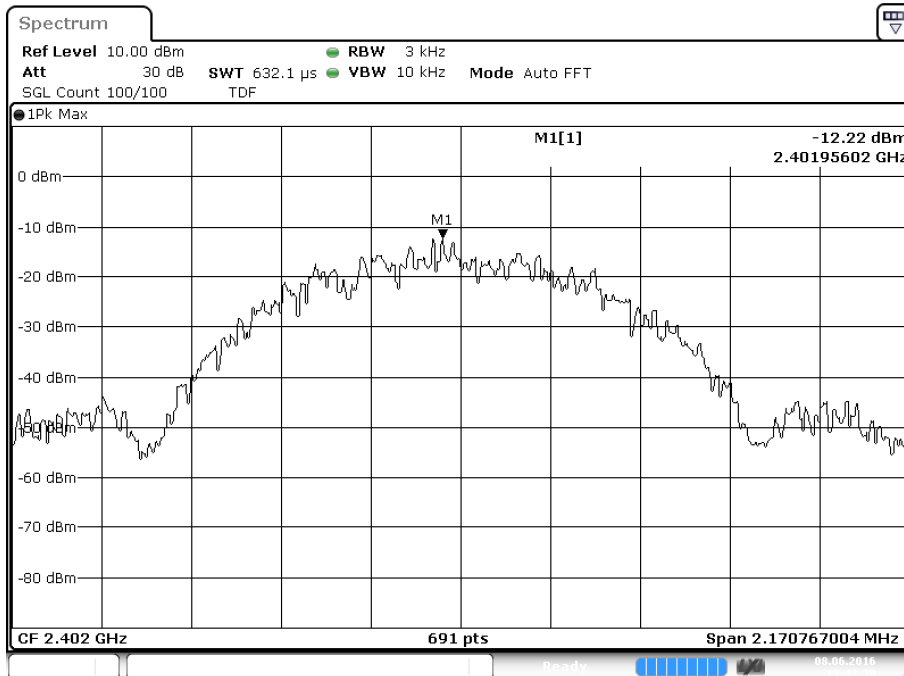

Ble,0 : BLE Power spectral density (3KHz)
 Date: 8 JUN.2016 13:42:31

Power Spectral Density 3 kHz (channel 17)

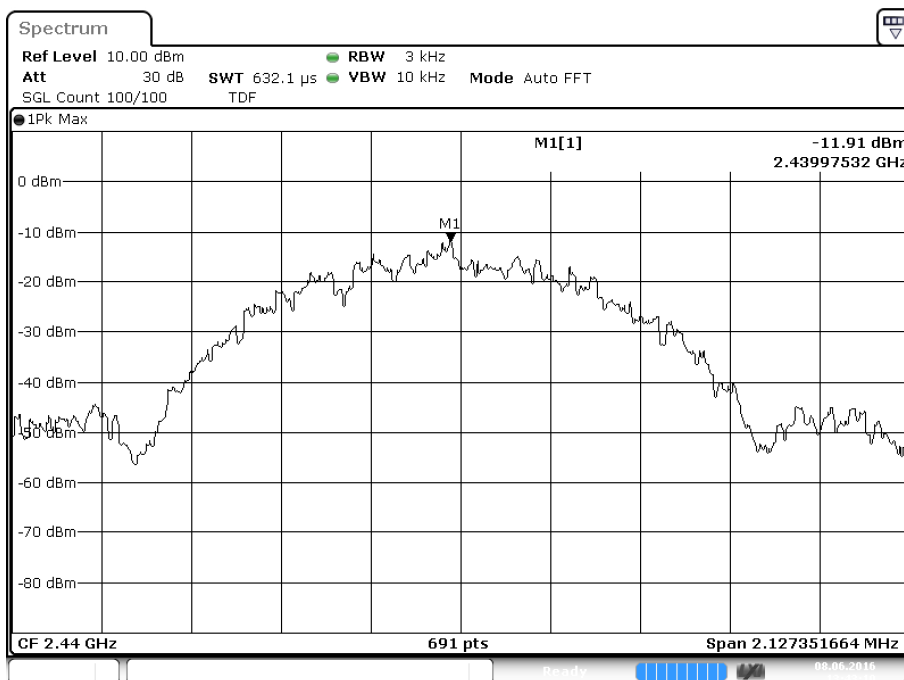

Ble,19 : BLE Power spectral density (3KHz)
 Date: 8 JUN.2016 13:43:10

Power Spectral Density 3 kHz (channel 39)

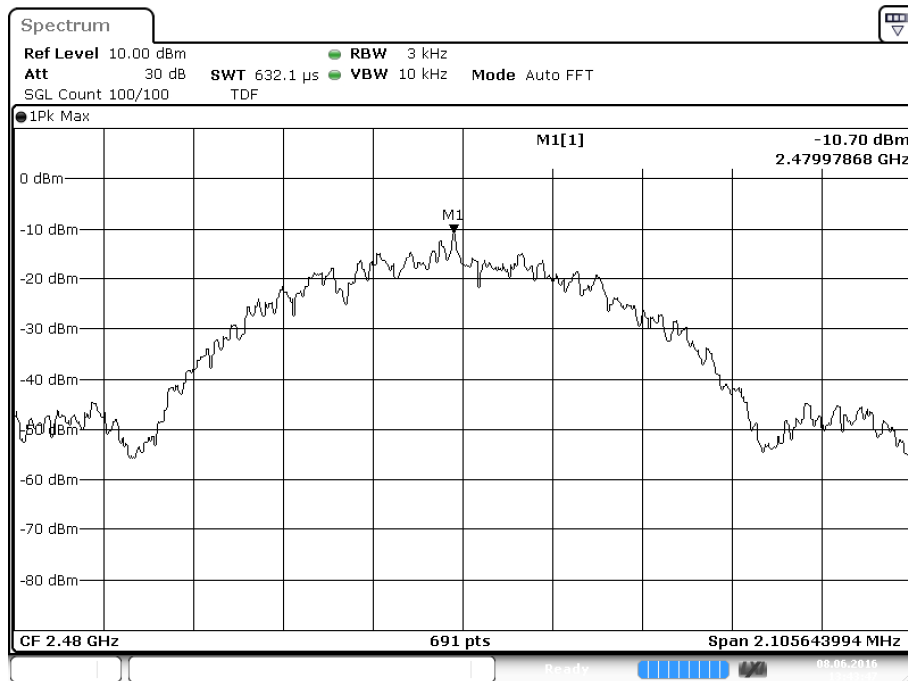

Ble,39 : BLE Power spectral density (3KHz)

Date: 8 JUN 2016 13:43:47

3.5 Radiated Spurious Emissions Measurement

3.5.1 Limit

The emissions from an intentional radiator shall not exceed the field strength levels specified in the following table:

15.209

Frequency (MHz)	Field strength ($\mu\text{V/m}$)	Measurement distance(m)
0.009 – 0.490	2400/F(kHz)	300
0.490 – 1.705	24000/F(kHz)	30
1.705 - 30	30	30
30 -88	100	3
88 - 216	150	3
216-960	200	3
Above 960	500	3

3.5.2 Measurement instruments

The measurement instruments are listed in chapter 2.4 of this report.

3.5.3 Test setup

The test setup is as shown in chapter 2.3 of this report.

3.5.4 Test procedure

The emission limits shown in the above table are based on measurements employing a CISPR quasi-peak detector except for the frequency bands 9–90 kHz, 110–490 kHz and above 1000 MHz. Radiated emission limits in these three bands are based on measurements employing an average detector.

Other details are according to KDB Publication 558074 V02r05, sections 11.3 and 12.1

3.5.5 Notes

- In the frequency range of 1 – 18 GHz the green trace is measured using a peak detector and the red trace is measured using an average detector. The top limit line represent the peak limit and the bottom limit represents the average limit

3.5.6 Plots of the Radiated Spurious Emissions Measurement

30 – 1000 MHz

Vertical polarization

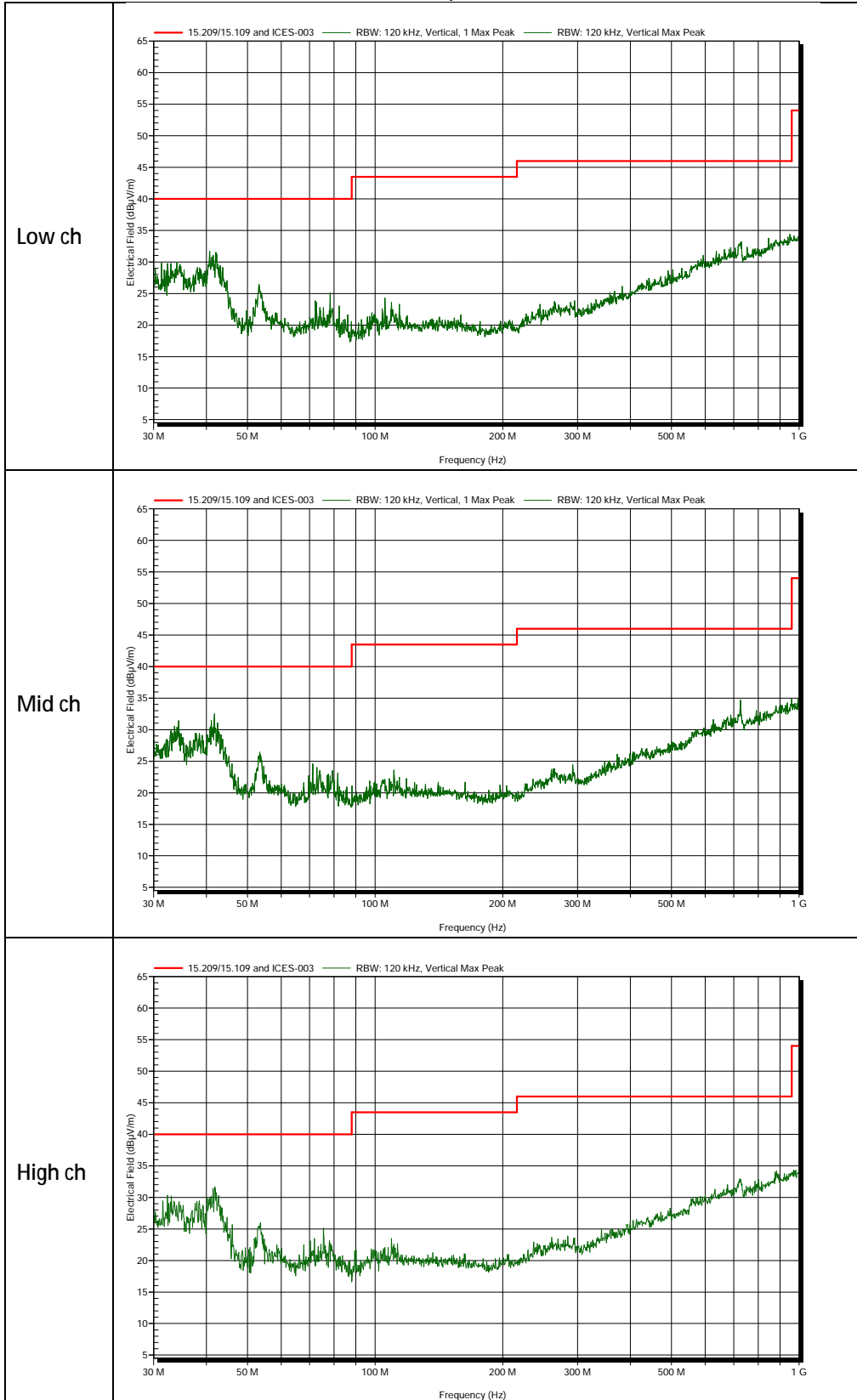

30 MHz to 1 GHz

Horizontal polarization

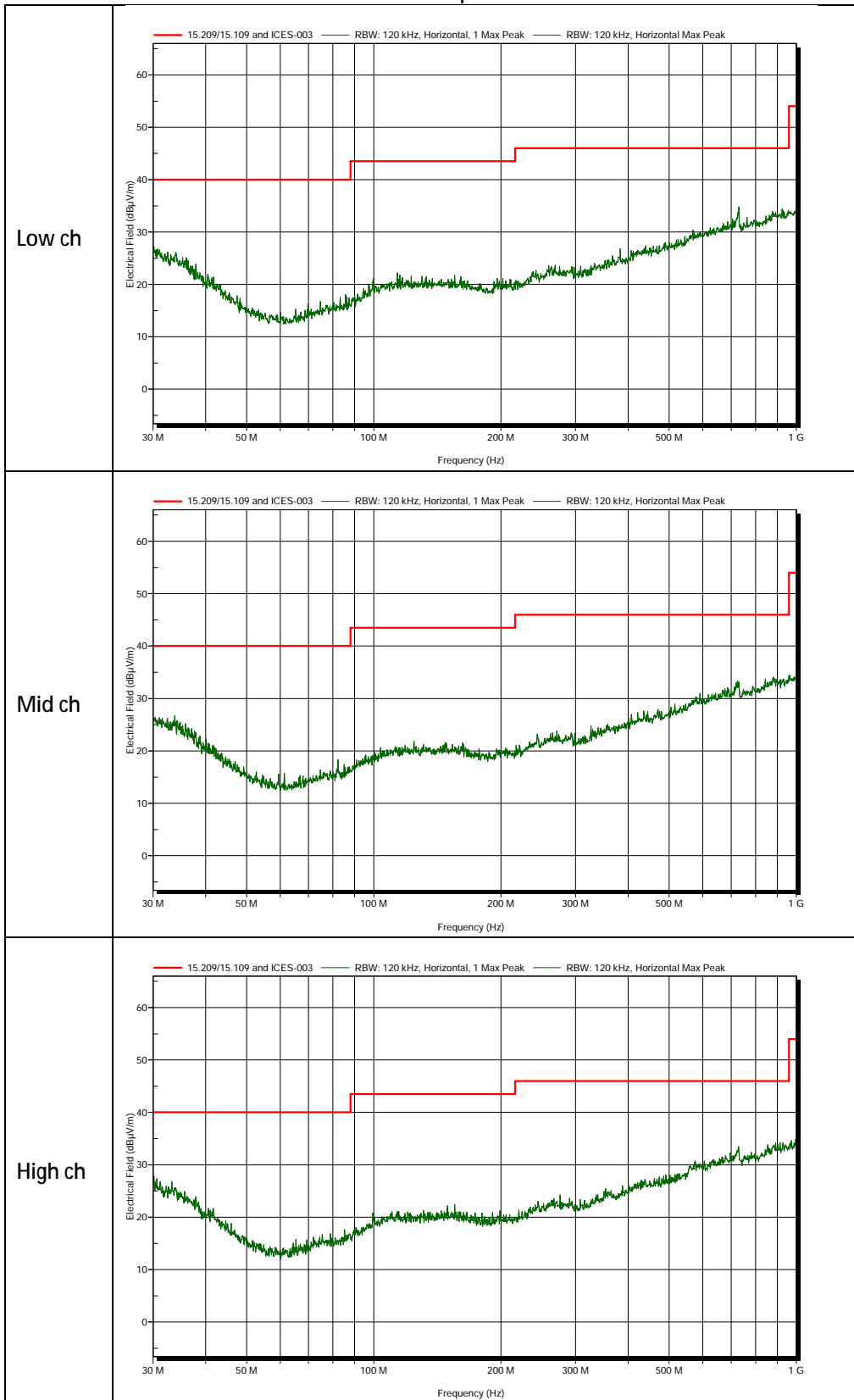

1 GHz to 18 GHz

Horizontal polarization

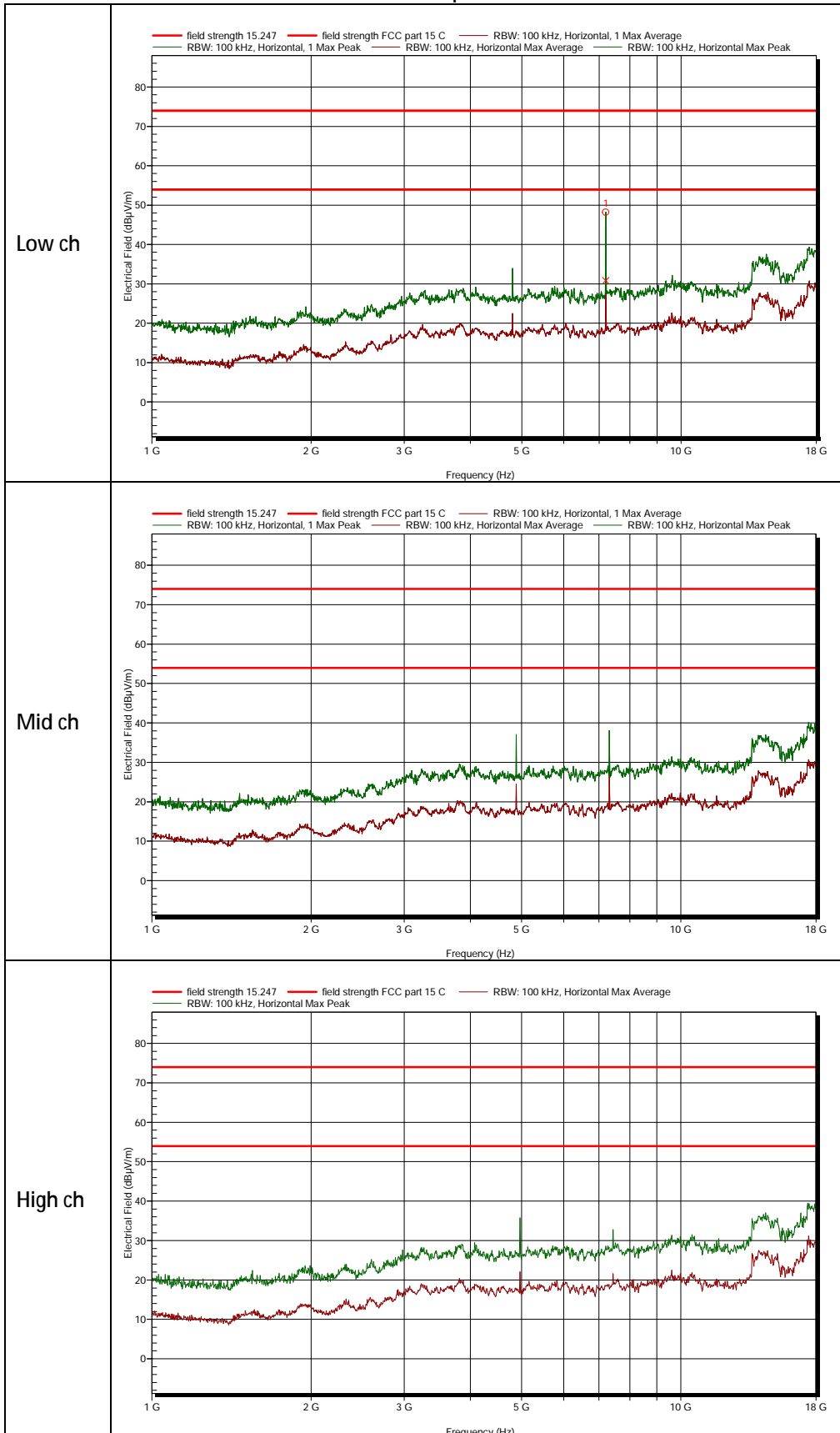

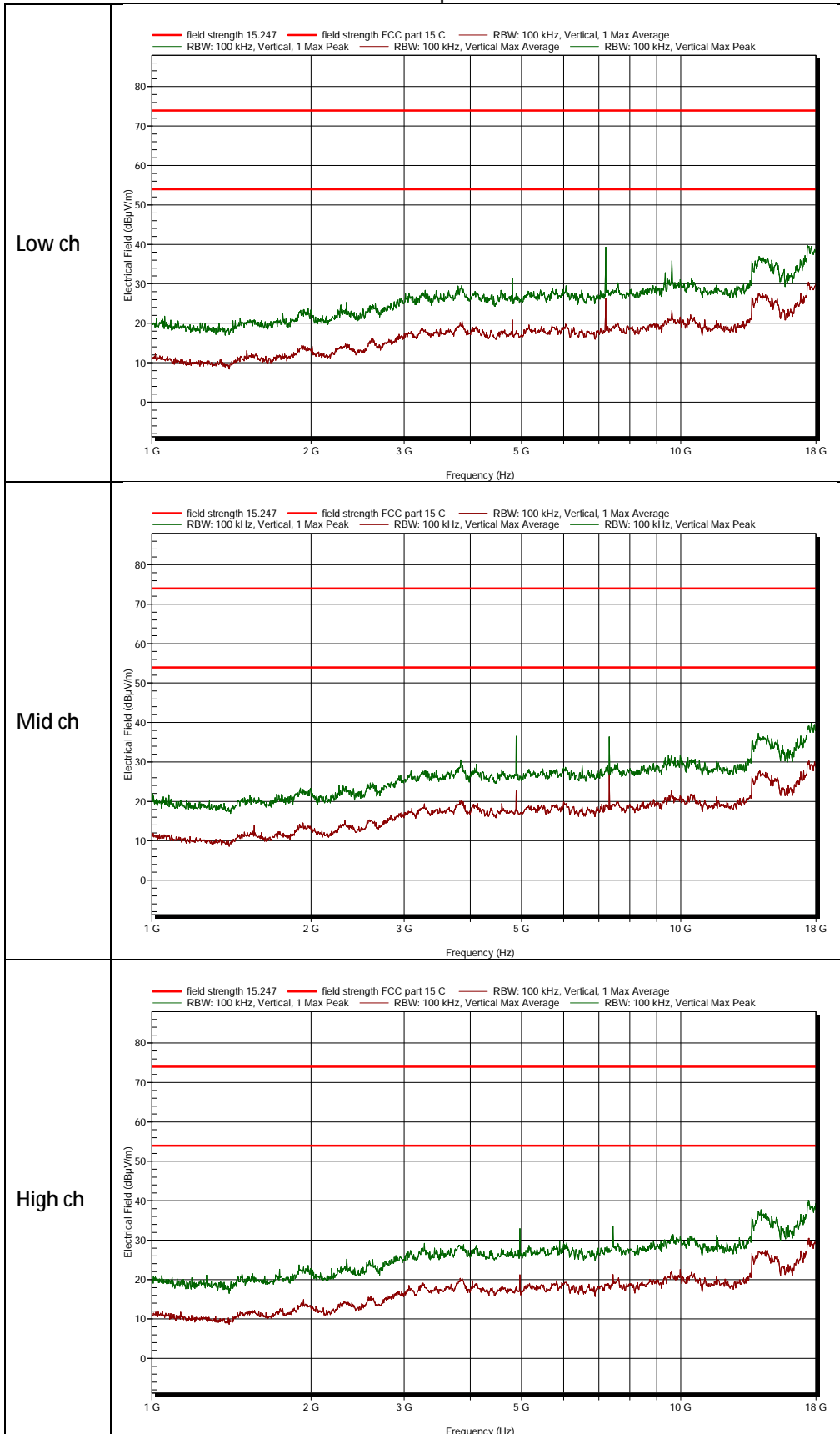
Vertical polarization

18 GHz to 26 GHz

No radiated emission tests were performed since the conducted emissions test did not reveal any results above measurement system noise floor.

3.5.7 Measurement Uncertainty

Horizontal polarization	
30 – 200 MHz	4.5 dB
200 – 1000 MHz	3.6 dB
Vertical polarization	
30 – 200 MHz	5.4 dB
200 – 1000 MHz	4.6 dB
1000- 18000 MHZ	+ 5.7/- 5.7dB

3.6 Conducted Spurious Emissions Measurement

3.6.1 Limit

In any 100 kHz bandwidth outside the frequency band in which the spread spectrum or digitally modulated intentional radiator is operating, the RF power shall be at least 20 dB below that in the 100 kHz bandwidth within the band that contains the highest level of desired power.

3.6.2 Measurement instruments

The measurement instruments are listed in chapter 2.4 of this report.

3.6.3 Test setup

The test setup is as shown in chapter 2.3 of this report.

3.6.4 Test procedure

The testing follows FCC KDB Publication No. 558074 D01 DTS Meas. Guidance v03r05.

3.6.5 Plots of the Conducted Spurious Emissions Measurement

0.03 – 3 GHz

See next page.

3.6.6 Measurement Uncertainty

< 1 GHz	1.27 dB
≥ 1 GHz	2.53 dB

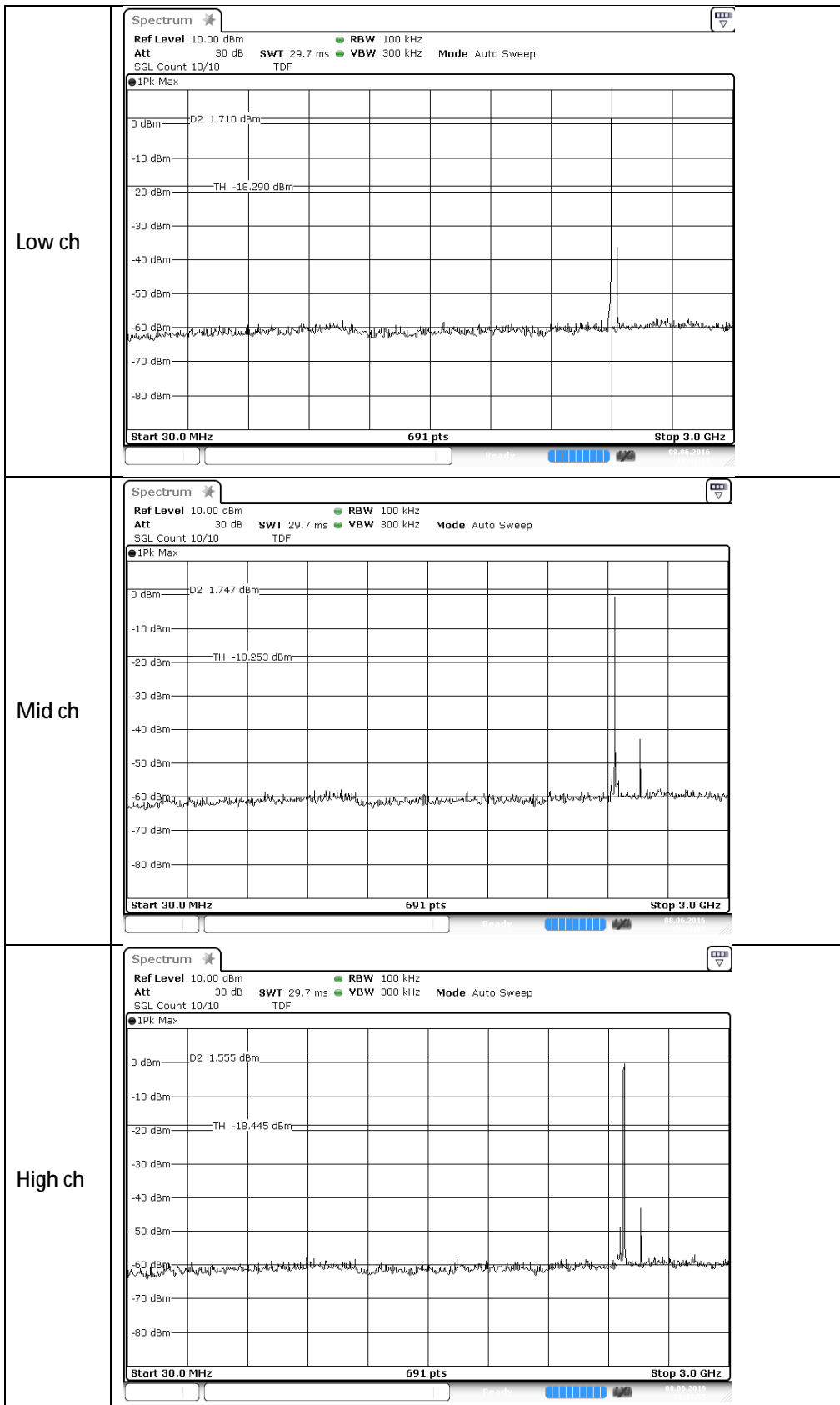

2-26 GHz

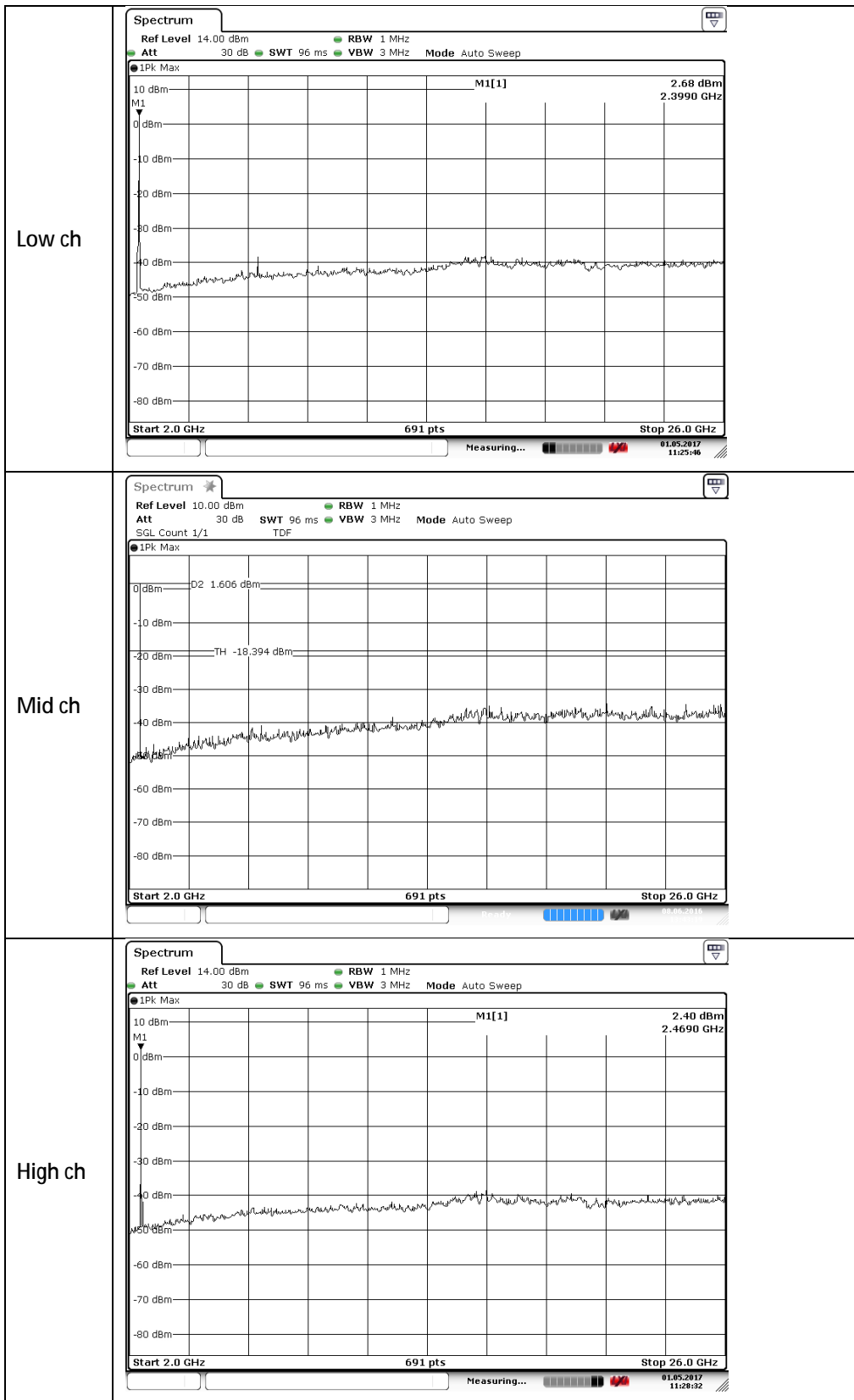

3.7 Band edge emissions in the authorized band

3.7.1 Limit

At least 20 dB attenuation in a 100 kHz bandwidth relative to the highest fundamental channel power spectral density in 100 kHz.

3.7.2 Measurement instruments

The measurement instruments are listed in chapter 2.4 of this report.

3.7.3 Test setup

The test setup is as shown in chapter 2.3 of this report.

3.7.4 Test procedure

The testing follows FCC KDB Publication No. 558074 D01 DTS Meas. Guidance v03r05.

3.7.5 Test results of band edge measurements

Technology Std.	Channels	Peak method		
		Frequency (MHz)	Data rate	Attenuation (dB)
Bluetooth Low Energy	37	2402	1 Mbps	40.41
	39	2480	1 Mbps	37.22
Uncertainty	+/- 1.7 dB			

3.7.6 Measurement Uncertainty

≥ 1 GHz	2.53 dB
---------	---------

3.7.7 Plots of the band edge measurements

Lower band edge

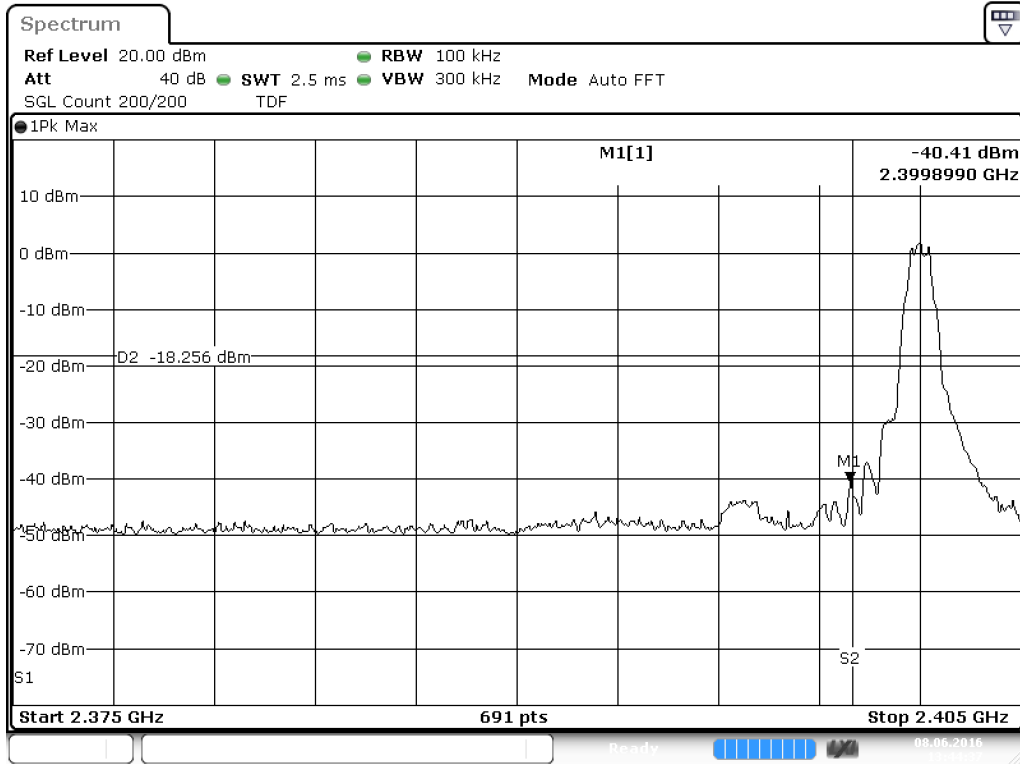

Higher band edge

