

Installation guide

XS4 Original+ Ai6xx...

SALTO
inspired access

- Eng Installation guide
- F Guide d'installation
- E Guía de instalación

A i 650xx series

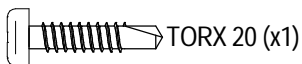
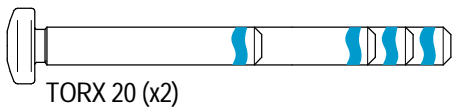
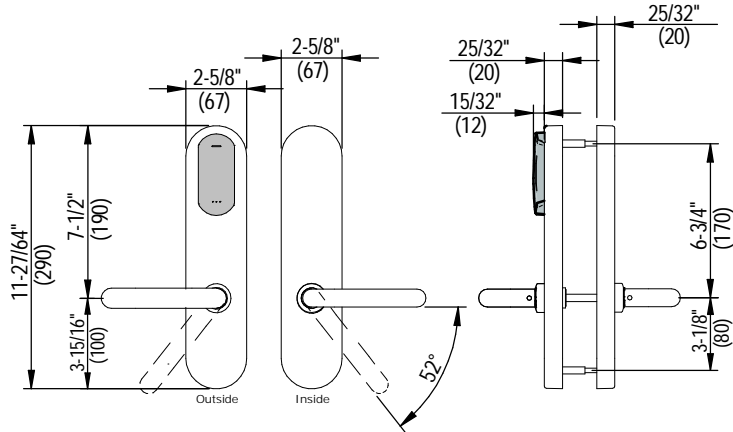

SALTO recommends the use of a mortise lock, with a maximum 4° pre-turn.
SALTO recommande d'utiliser des serrures à mortaiser avec un angle au repos de 4° maximum.
SALTO recomienda utilizar cerraduras con un pregiro máximo de 4°.

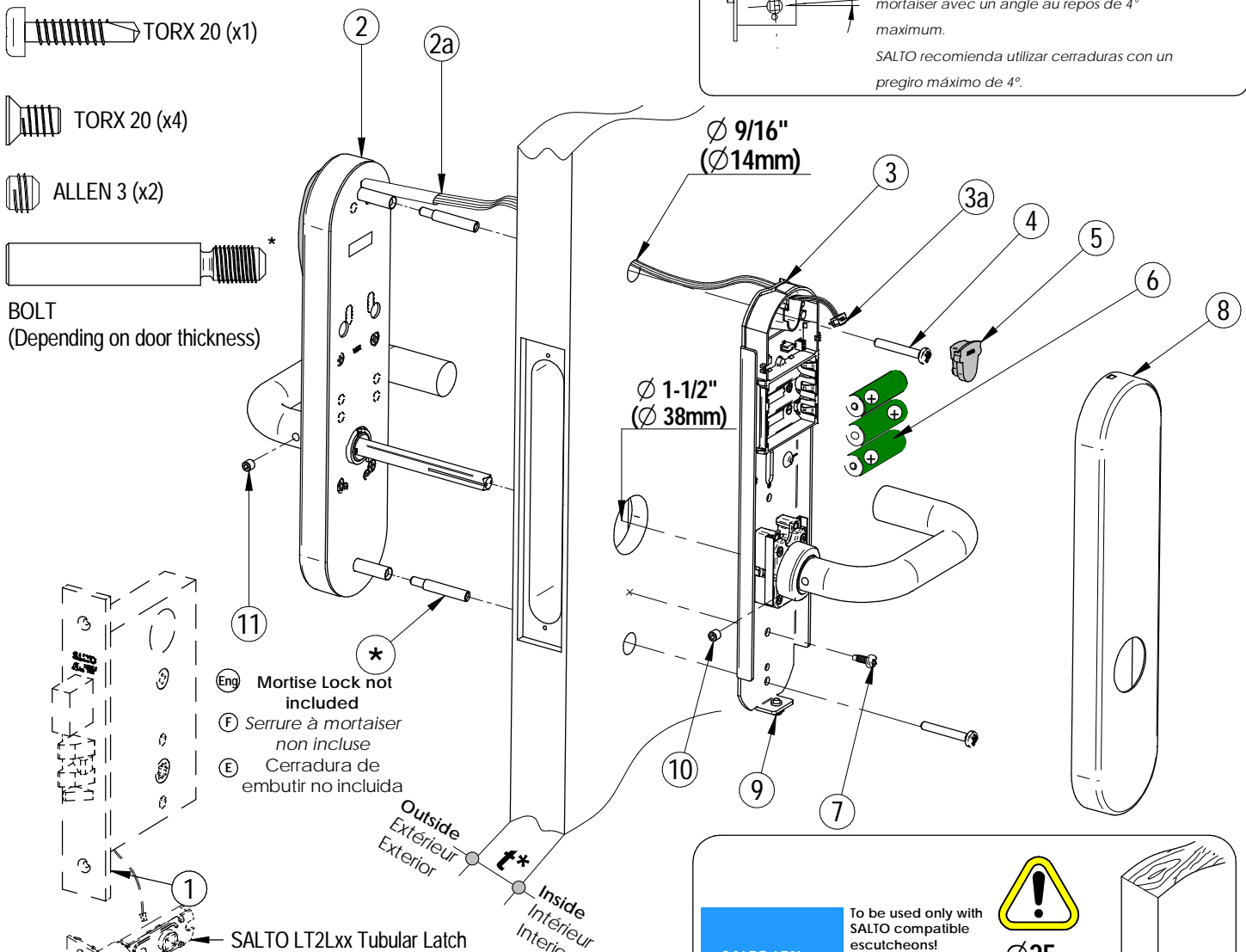

Eng Mortise Lock not included
F Serrure à mortaiser non incluse
E Cerradura de embutir no incluida

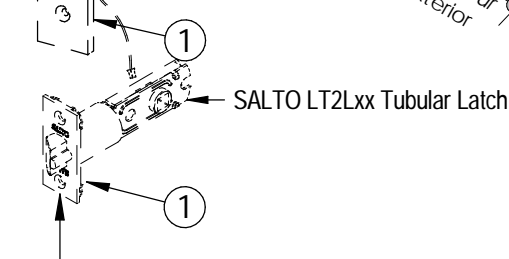

SALTO Tubular Latch to be included ALWAYS with the product!
Picaporte tubular SALTO a incluir SIEMPRE con el producto!

To be used only with SALTO compatible escutcheons!
A utiliser uniquement avec les ensembles plaques-béquilles SALTO compatibles!
¡Utilizar solamente con escudos SALTO compatibles!

SALTO LT2Lxx Tubular latch
With Ai6xxA2.. Only!

⚠️

Ø25
Ø1"

Installation guide

XS4 Original+ Ai6xx...

SALTO
inspired access

Eng Select handing (F) Choisir le sens de la bêteille (E) Seleccione mano

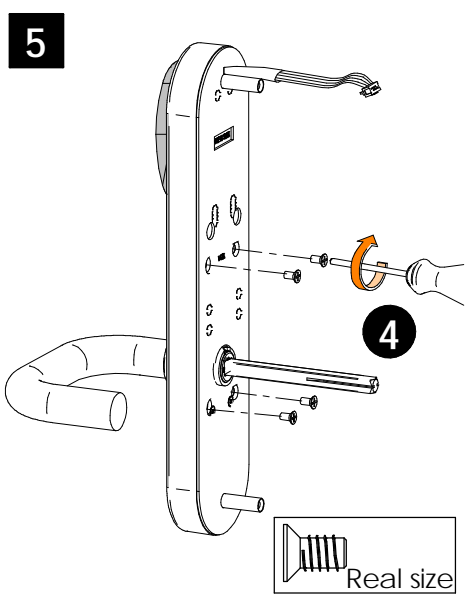
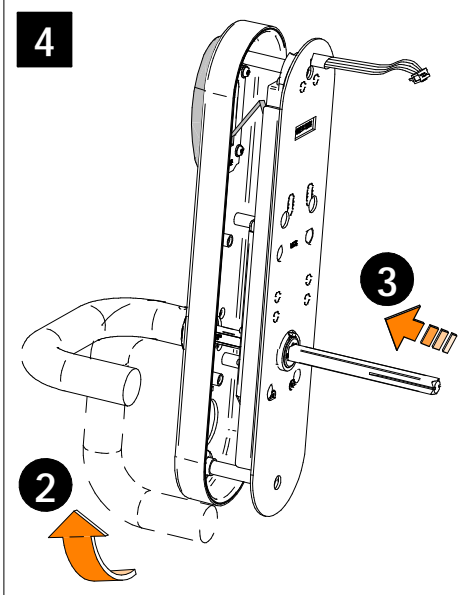
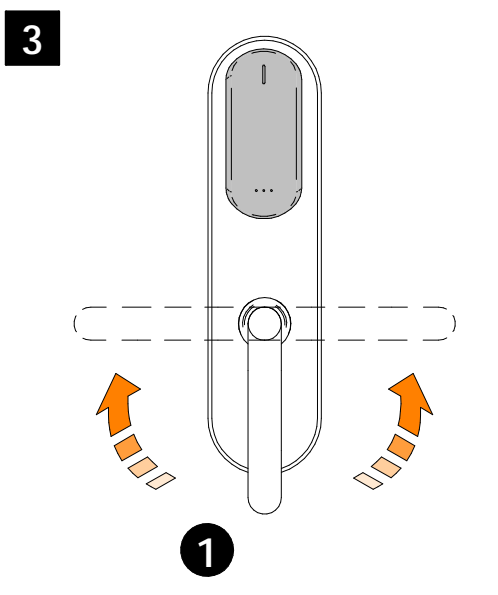
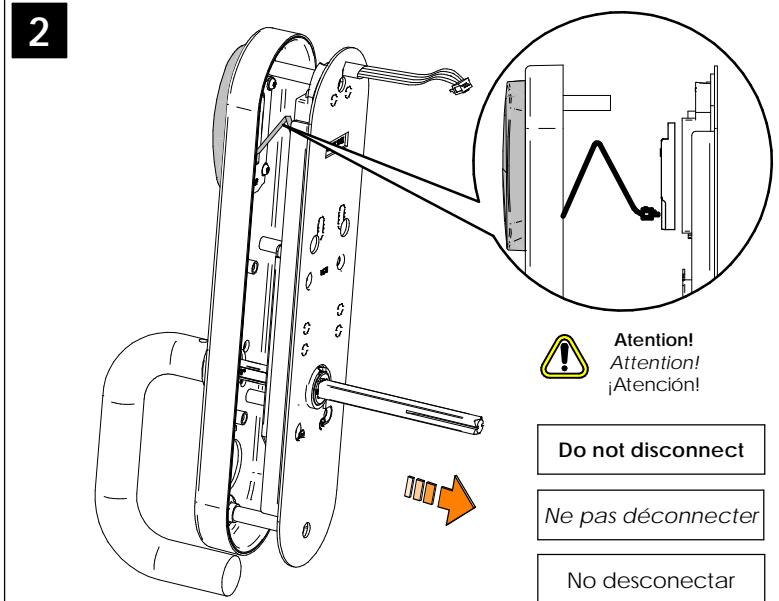
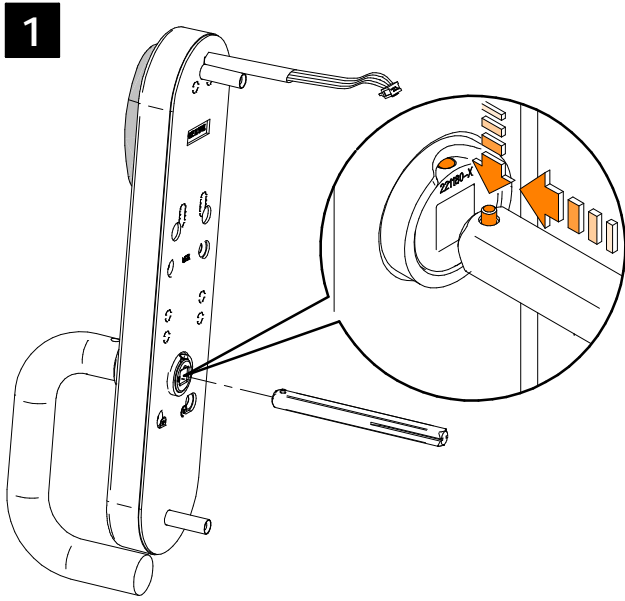

Eng Installation (F) Installation (E) Instalación

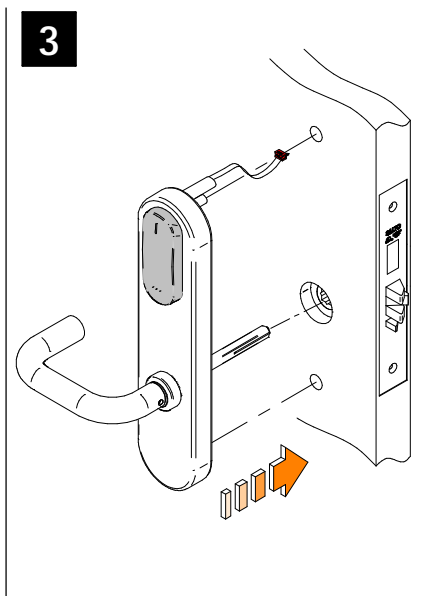
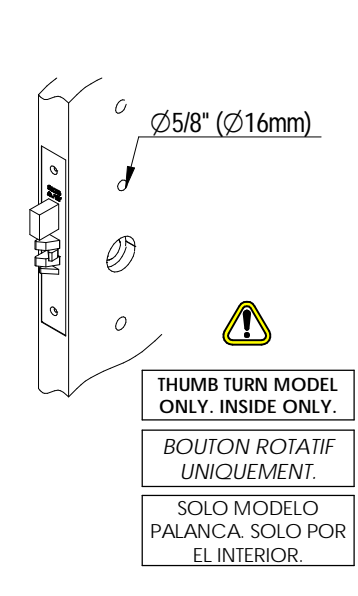
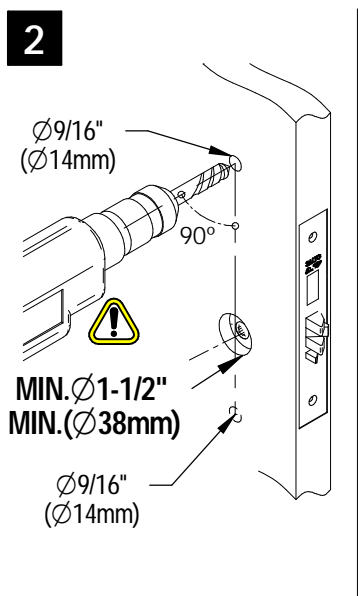
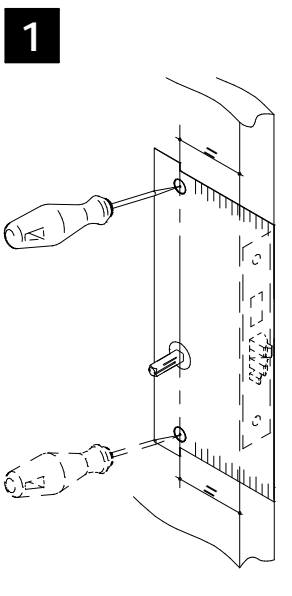

Installation guide

XS4 Original+ Ai6xx...

SALTO
inspired access

4

5

Real size
NOT OK

6

LR06

Real size

7

8

1

2

9

10

AT THIS POINT DO NOT CLOSE THE DOOR PROGRAM THE LOCK FIRST
Follow user manual

(F) NE FERMEZ PAS LA PORTE. PROGRAMMEZ LA BÉQUILLE AVANT
Consultez le manuel utilisateur

(E) NO CIERRE LA PUERTA. PROGRAME LA CERRADURA
Consulte el manual del usuario

Real size

(Eng) Battery change
(F) Remplacer les piles
(E) Cambio de pilas

MAX.40"
Change/Remplacer/Cambio

Installation guide

XS4 Original+ Ai6xx...

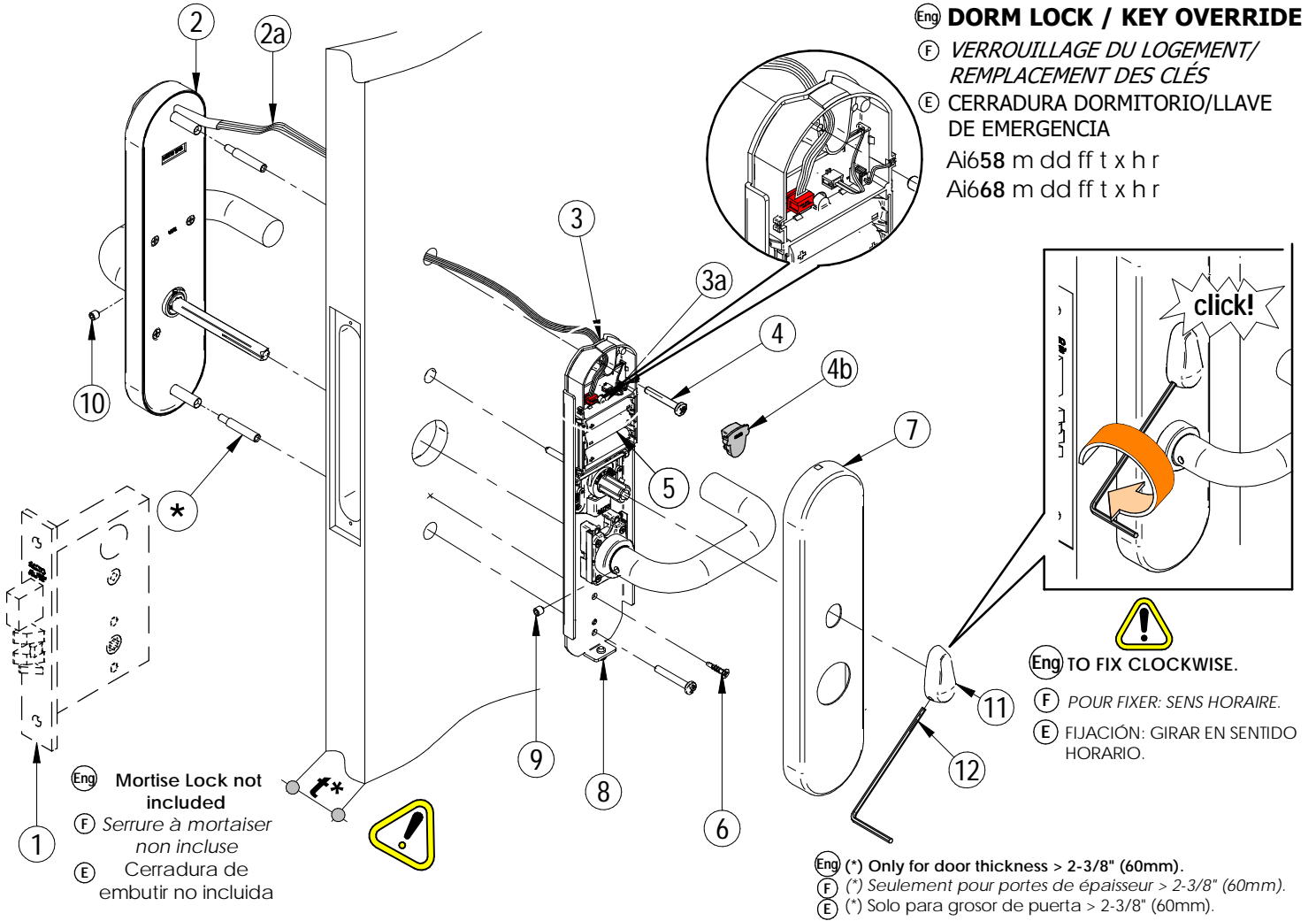

WIRELESS

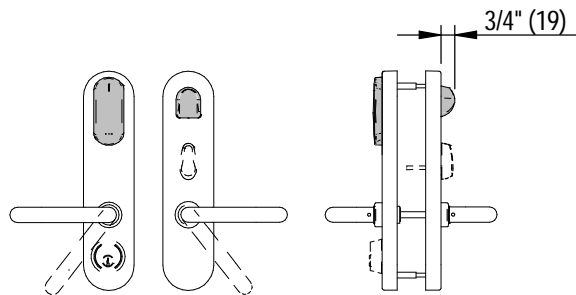

A i 650xx..W series

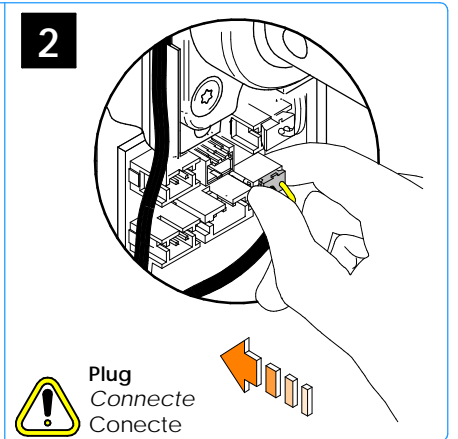
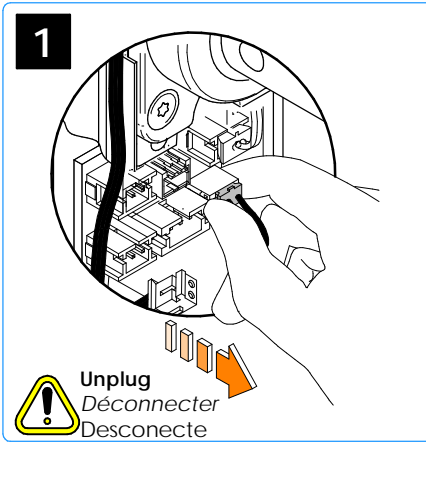
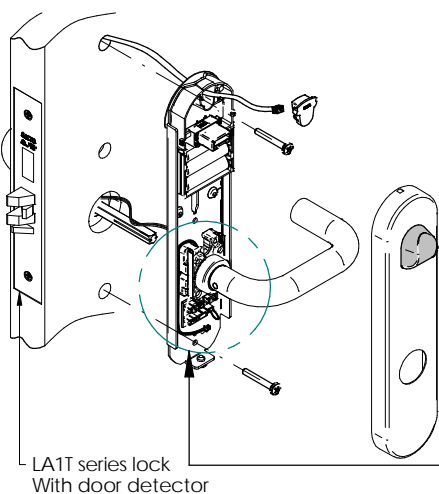

Installation guide

XS4 One+ Ai9xx...

SALTO
inspired access

Ai 950 xx series

- (Eng) Installation guide
- (E) Guía de instalación
- (D) Montageanleitung
- (F) Guide d'installation
- (I) Guida all'installazione
- (P) Guia de instalação

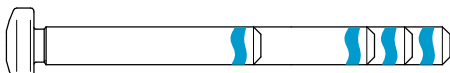
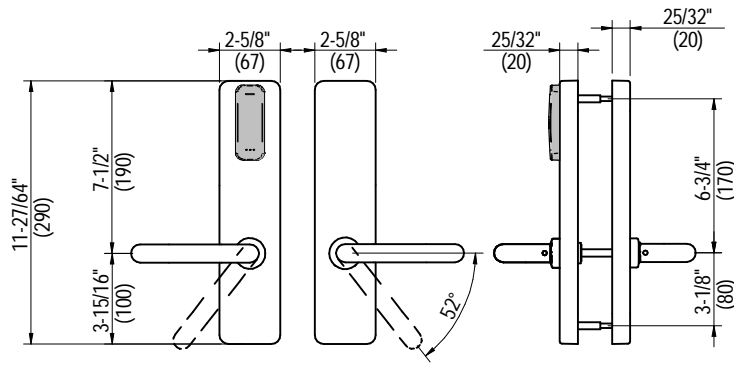

TORX 20 (x2)



TORX 20 (x1)



TORX 20 (x4)

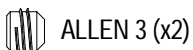

ALLEN 3 (x2)

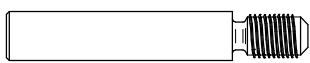

Mortise Lock not included
Cerradura de embutir no incluida

(Eng) * Required only for doors that exceed 60mm [2-3/8"] thickness

(E) * Sólo para puertas de espesor mayor de 60mm [2-3/8"]

SALTO Tubular Latch to be included ALWAYS with the product!
Picaporte tubular SALTO a incluir SIEMPRE con el producto!

SALTO LT2Lxx
Tubular Latch

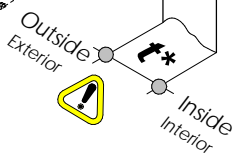

SALTO recommends the use of a mortise lock, with a maximum 4° pre-turn.
SALTO recommande d'utiliser des serrures à mortaiser avec un angle au repos de 4° maximum.
SALTO recomienda utilizar cerraduras con un pregiro máximo de 4°.

To be used only with SALTO compatible escutcheons!
A utiliser uniquement avec les ensembles plaques-béquilles SALTO compatibles!
¡Utilizar solamente con escudos SALTO compatibles!

SALTO LT2Lxx Tubular latch
With Ai6xxA2.. Only!

Ø25
Ø1"

Installation guide

XS4 One+ Ai9xx...

SALTO
inspired access

(Eng) Select handing (E) Selección mano (D) Drückerrichtung wählen (F) Choisir le sens de la bêche
(I) Scegliere il verso (P) Seleção mão

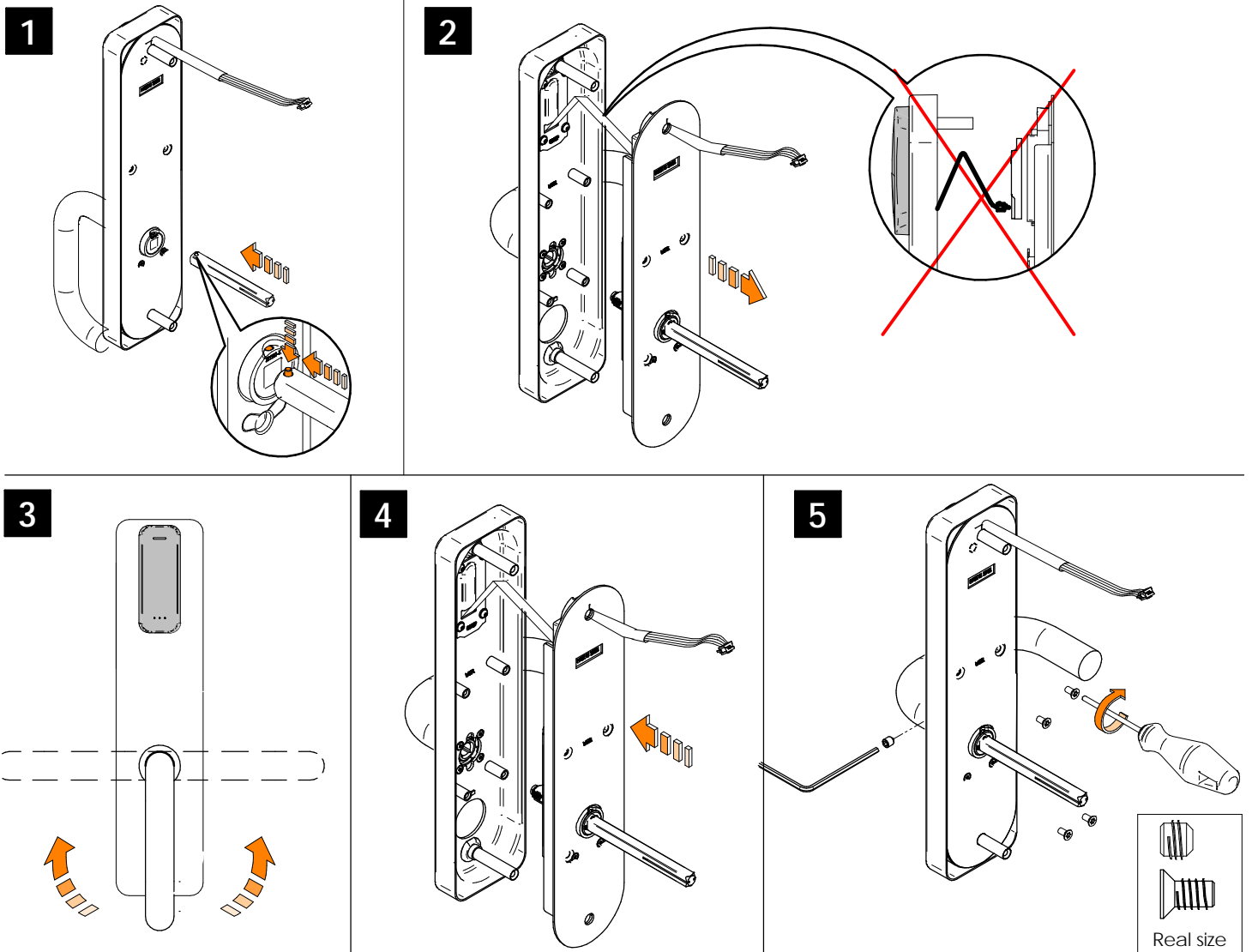

(Eng) Installation (E) Instalación (D) Installation (F) Installation (I) Installazione (P) Instalação

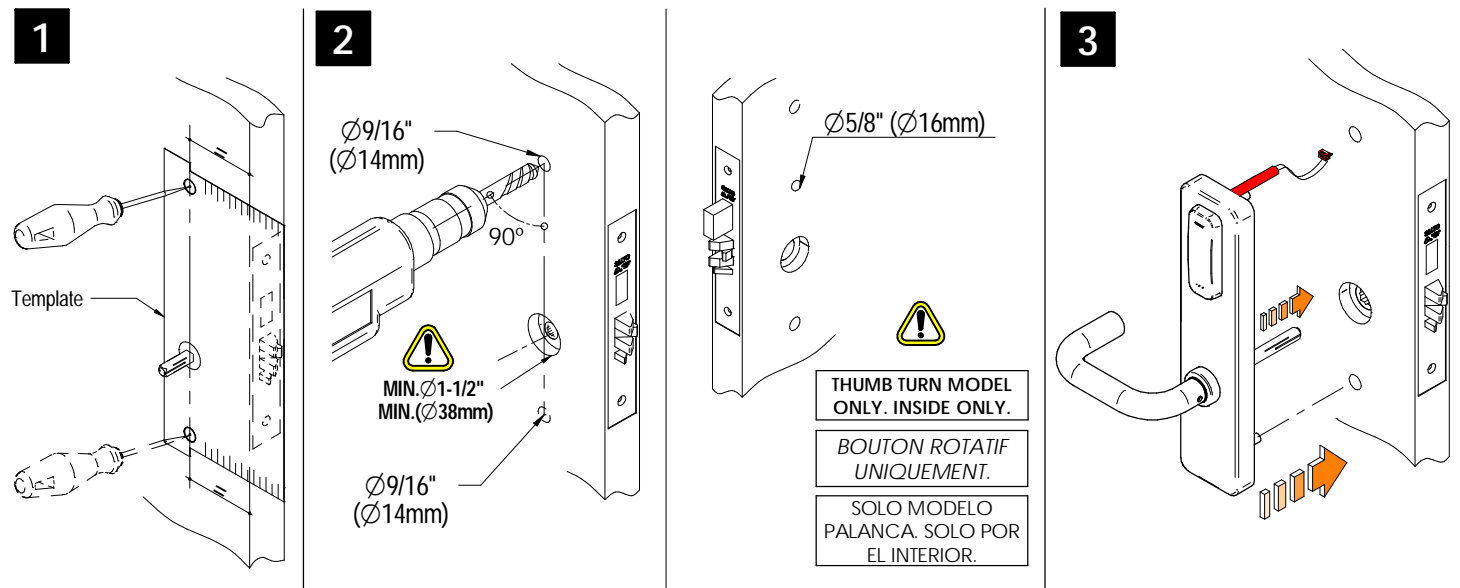

Installation guide

XS4 One+ Ai9xx...

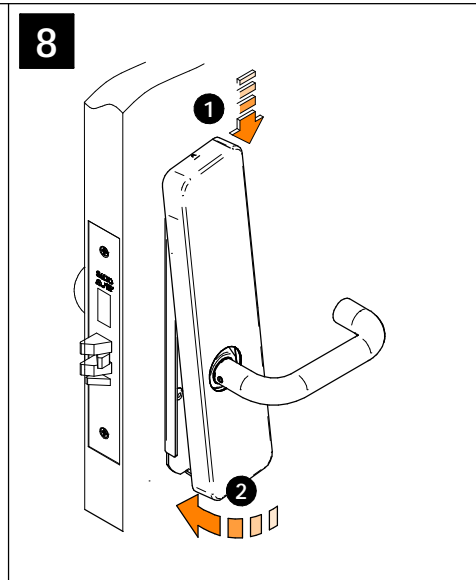
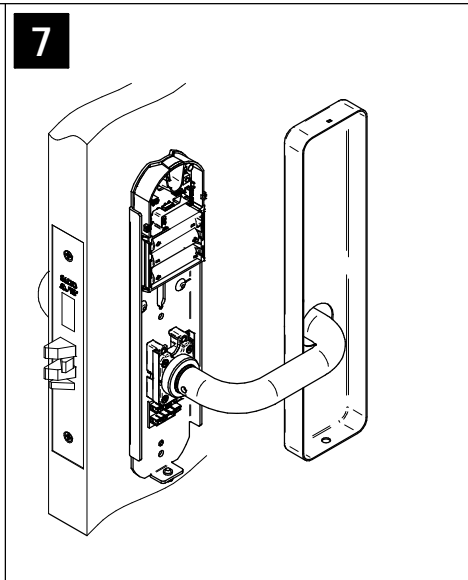
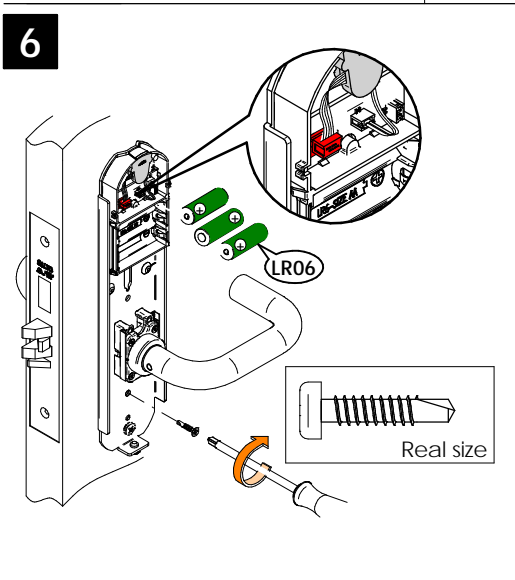
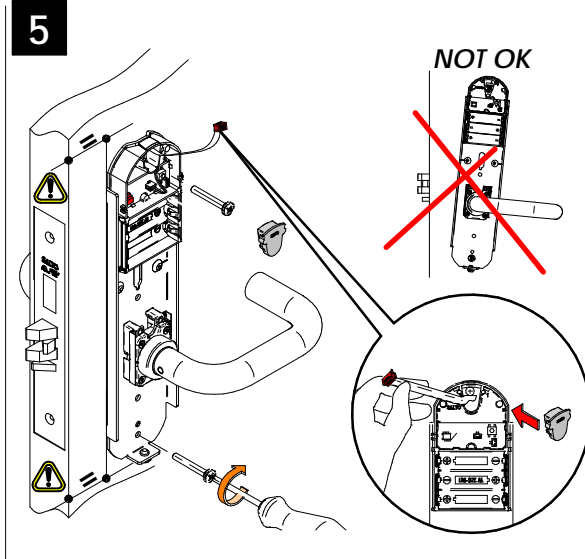
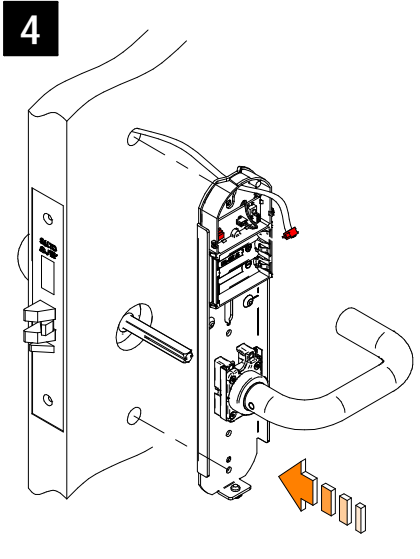

9

- (Eng) AT THIS POINT DO NOT CLOSE THE DOOR PROGRAM THE LOCK FIRST
- (E) NO CIERRE LA PUERTA. PROGRAME LA CERRADURA
- (D) TÜR NICHT SCHLIESSEN. ZUERST SCHLOSS PROGRAMMIEREN
- (F) NE FERMEZ PAS LA PORTE. PROGRAMMEZ LA BÉQUILLE AVANT
- (I) PROGRAMARE LA SERRATURA PRIMA DI CHIUDERE LA PORTA

(Eng) Battery change
(F) Remplacer les piles
(E) Cambio de pilas

Installation guide

XS4 One+ Ai9xx...

SALTO
inspiredaccess

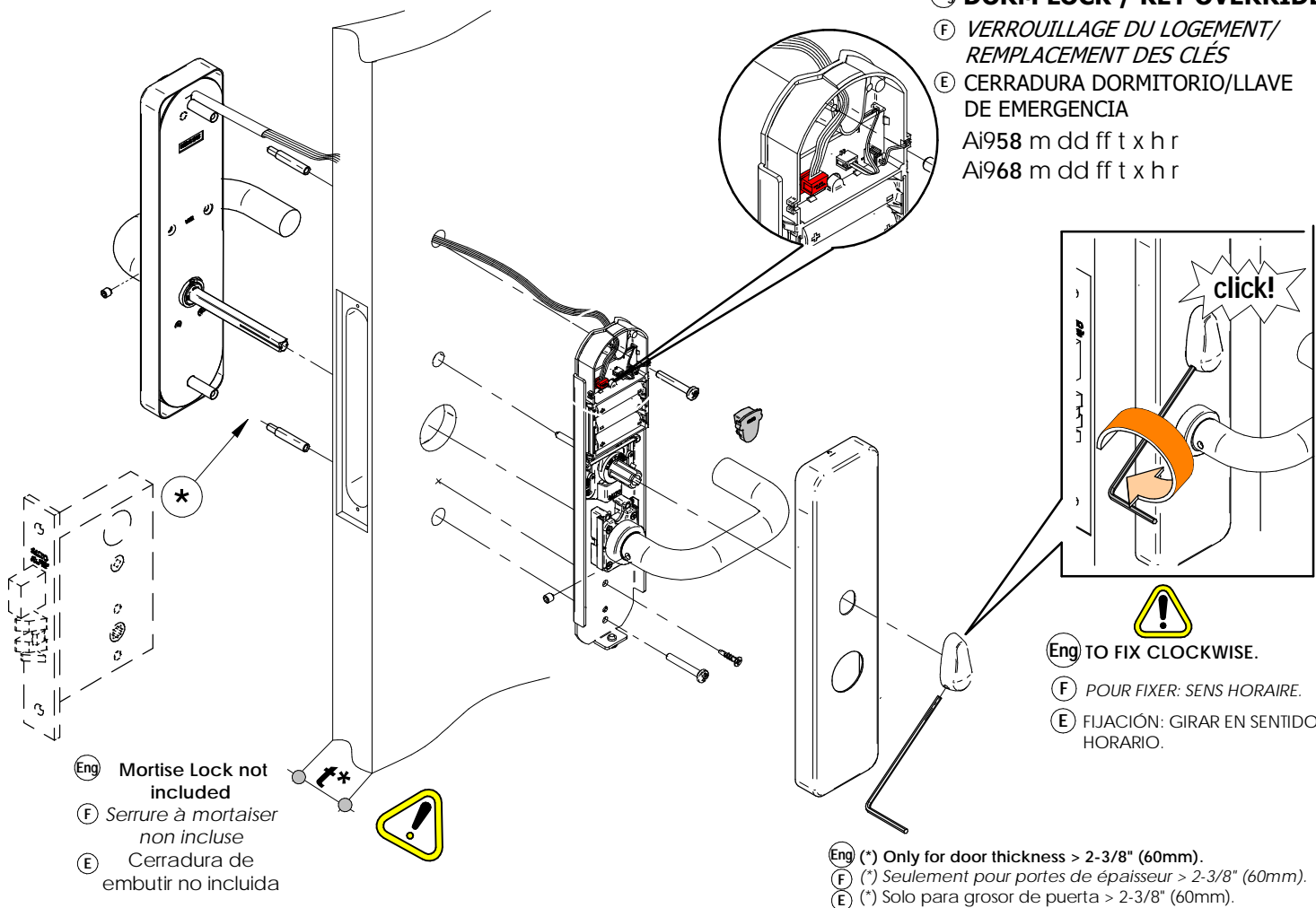

WIRELESS

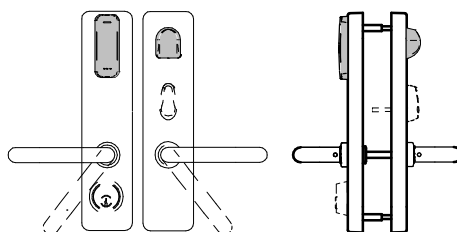

A i 950xx..W series

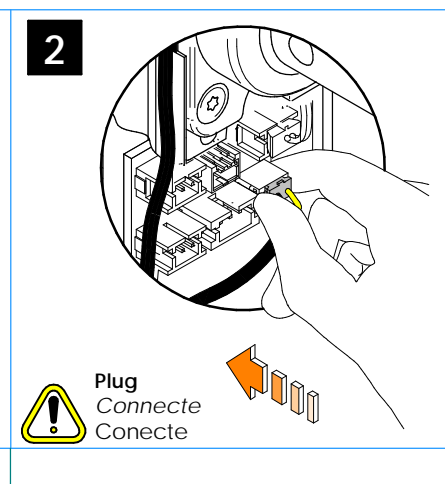
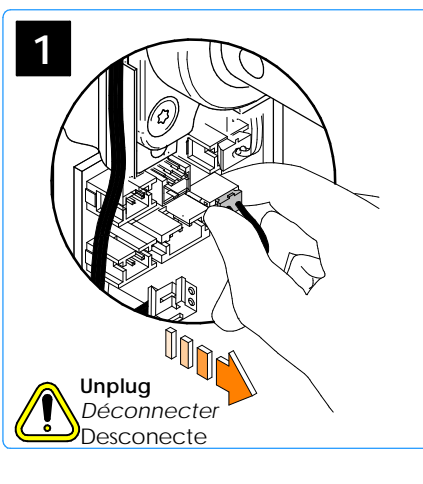
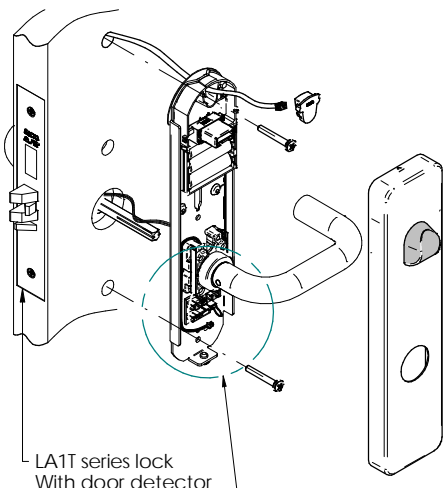

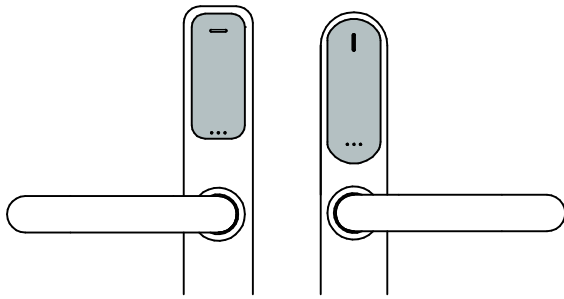

SALTO XS4 Original+ / XS4 One+

Additional Information

The XS4 Original+ / XS4 One+ product is a universal compatible state-of-the-art electronic escutcheon that brings the smart lock to a new technology level, combining the latest innovation in security, connectivity, and design into a battery-operated access control device.

EN Signalling ES Señalética DE Signalisierung FR Signal NL Signaal DK Signalering IT Segnaletica PT Sinal SV Signal NO Signal FI Signaalit

EN) Acces granted ES) Apertura normal DE) Zutritt gewährt FR) Accès accordé NL) Toegang verleend DK) Adgang tildelt	IT) Accesso garantito PT) Acesso autorizado SV) Tillträde beviljat NO) Adgang godkjent FI) Pääsy sallittu	EN) Access denied ES) Rechazo DE) Zutritt verweigert FR) Accès refuse NL) Toegang geweigerd DK) Adgang afvist	IT) Accesso negato PT) Acesso negado SV) Tillträde nekat NO) Adgang nektet FI) Pääsy evätty	EN) Low battery status ES) Pilas bajas DE) Niedriger Batteriestand FR) Statut pile faible NL) Laag batterijniveau DK) Lav batteristatus	IT) Status batteria bassa PT) Status de bateria fraca SV) Låg batteristatus NO) Lavt batterinivå FI) Matala pariston tila	EN) Battery change ES) Cambio de pilas DE) Batteriewechsel FR) Remplacement de la pile NL) Batterijwissel DK) Batteriskift	IT) Cambio batterie PT) Troca de bateria SV) Batteribyte NO) Batteribytte FI) Pariston vaihto
--	---	--	---	--	---	---	---

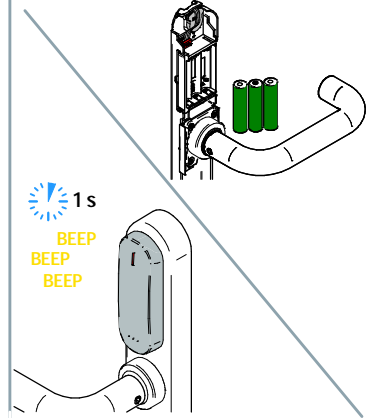
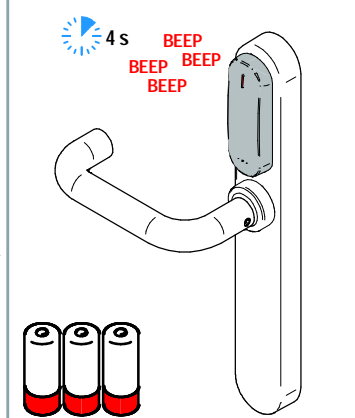
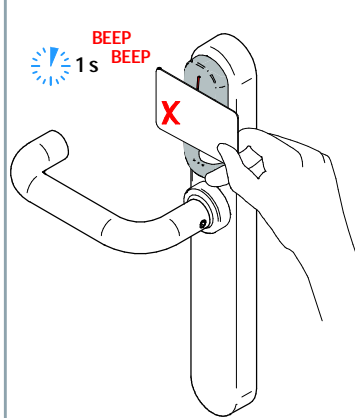
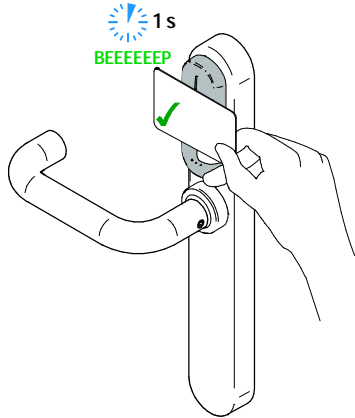

EN) Office mode notice ES) Puesta en paso DE) Office-Modus aktiviert FR) Notice du Mode Office NL) Loopstand ingeschakeld DK) Kontortilstand aktiveret	IT) Avviso Modalità ufficio PT) Aviso de modo office SV) Notis om kontorsläge NO) Kontor funksjon aktivert FI) Päiväkäyttötilan ilmoitus
---	--

EN) Office mode end ES) Fin paso DE) Office-Modus deaktiviert FR) Fin du mode office NL) Loopstand uitgeschakeld DK) Kontortilstand afsluttet	IT) Fine modalità ufficio PT) Fim do modo office SV) Avsluta kontorsläge NO) Kontor funksjon avsluttet FI) Päiväkäyttötilan lopetus
--	---

EN) Toggle mode ES) Modo toggle DE) Mediensteuert Modus FR) Mode alterné NL) Toggle-stand DK) Toggle tilstand aktiveret	IT) Azione PT) Alternar SV) Toggle NO) Veksle FI) Tilanvaihto
--	---

EN) Toggle mode end ES) Fin modo toggle DE) Mediensteuert Modus beendet FR) Fin du mode alterné NL) Einde Toggle-stand	IT) Fine azione PT) Terminar o modo alternar SV) Avsluta toggle NO) Veksle modus avsluttet FI) Tilanvaihtu lopetettu
--	--

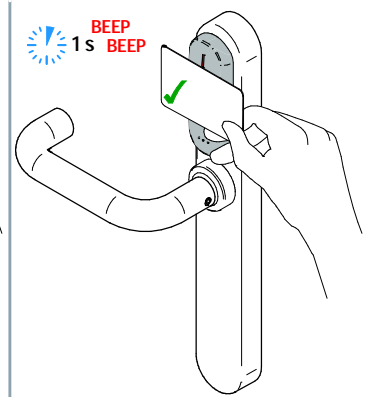
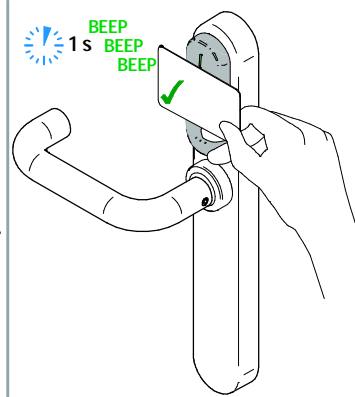
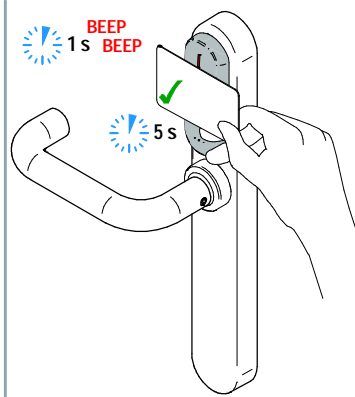
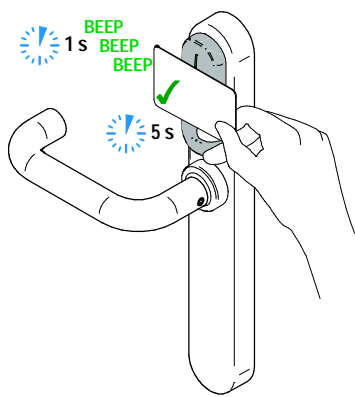

EN) Program PPD ES) Programar PPD DE) Programmieren PPD FR) Programmer PPD NL) Programmeren PPD DK) Tidsplan PPD	IT) Programmare PPD PT) Programar PPD SV) Schema PPD NO) Plan PPD FI) Aikataulu PPD
---	---

EN) Security error ES) Error de seguridad DE) Sicherheitsfehler FR) Erreur de sécurité NL) Beveiligingsfout DK) Sikkerhedsfej	IT) Errore sicurezza PT) Erro de segurança SV) Säkerhetsfel NO) Sikkerhets feil FI) Turvallisuusvirhe
--	---

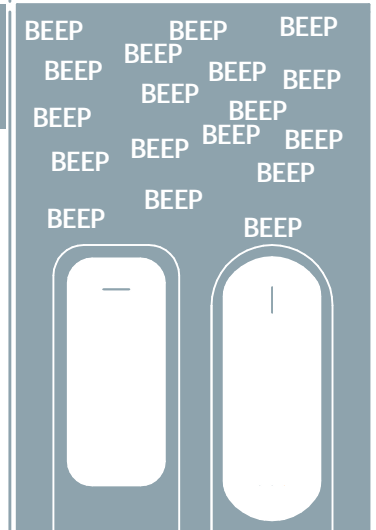
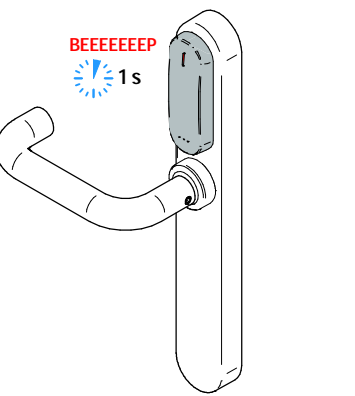
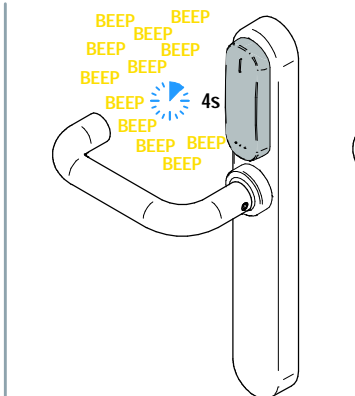
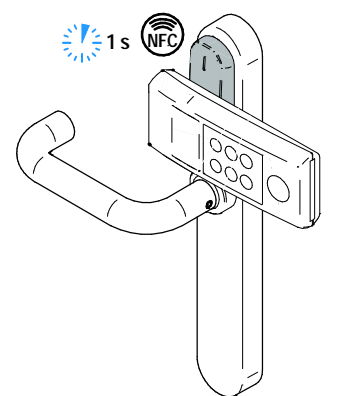

ELECTRICAL FEATURES

OPERATING CONDITIONS		
	Min.	Max.
Temperature (OUTSIDE)	-35°C	60°C
Temperature (INSIDE)	With LR03 Batteries	-5°C
	With FR03 batteries	50°C
	-35°C	60°C
Humidity	0°C	95% (Non-Condensing)

SALTO BLUEnet FEATURES	
Frequency Range	2400-2483.5 MHz
Standard	Bluetooth 5.2 Compliant
Output TX power	+6 dBm
Indoor Range	10-15m *

* Depending upon installed environment. To ensure correct operation, do not install the device near a metallic surface.

RFID CHARACTERISTICS	
Central Frequency	13,56MHz

CONFIGURATION

El dispositivo se configura mediante el software de gestión (ver guía de usuario correspondiente).

EJEMPLO DE INSTALACIÓN

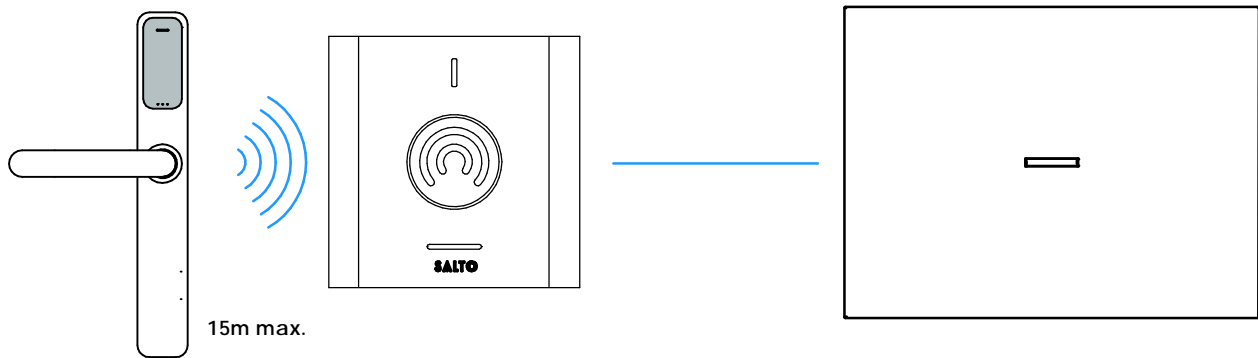

In case the device is surrounded by metal surfaces or metallic environment, radio performance could be seriously affected.

TEST OPERATIONAL

Comprobar funcionamiento con llave de obra.

PRODUCTS DESCRIPTION

PRODUCT		TECHNOLOGY			SOFTWARE						
COMMERCIAL NAME	MODEL	RFID 13.56 MHz Output max. power	BLUETOOTH SMART 2400-2483.5 MHz Output max. power	IEEE802.15.4 2400-2483.5 MHz Output max. power	CONTROL	READER	BLE MODULE	RF2 MODULE	MOTOR	SoC	
										FUS	BLE Stack
XS4 Original E0102 (A)	W09	+25 dBm			0037	0132					
	W0B	+25 dBm	+8 dBm		0037	0132	0136				
	W0J	+25 dBm	+8 dBm		0037	0133	0136				
	W0S	+25 dBm	+2.8 dBm		0126	0132	-				
	W09W	+25 dBm		+5 dBm	0016/0061/0095	0132		0038/0099			
	W0BW	+25 dBm	+8 dBm	+5 dBm	0016/0095	0132/0140	0136	0038/0099			
	W0JW	+25 dBm	+8 dBm	+5 dBm	0016	0133	0136	0038			
	W08	+20 dBm			0037	0082					
XS4 Original with Keypad E1215 (A)	W08W	+20 dBm		+5 dBm	0016/0061	0082		0038			
	W0BK	+25 dBm	+8 dBm		0016/0095	0132	0136				
	W0JK	+25 dBm	+8 dBm		0016	0133	0136				
	W0SK	+25 dBm	+2.8 dBm		0126	0132	-				
	W0BWK	+25 dBm	+8 dBm	+5 dBm	0016/0095	0132/0140	0136	0038/0099			
XS4 Original+ E2131 (A)	W0JWK	+25 dBm	+8 dBm	+5 dBm	0016	0133	0136	0038			
	W40M	+25 dBm	+6 dBm		0174				0179	0186	0187
XS4 One+ E2131 (A)	W60M	+25 dBm	+6 dBm		0174				0179	0186	0187
	W80M	+25 dBm	+6 dBm		0174				0179	0186	0187
XS4 Original i-Button E0127 (B)	W60M	+25 dBm	+6 dBm		0174				0179	0186	0187
	W02				0023/0024/ 0025						

(A) EU DECLARATION OF CONFORMITY

EN Hereby, SALTO Systems S.L. (Arkotz Kalea (Pol. Lanbarren), 9 – 20180 Oiartzun– Spain), declares that this access control equipment is in compliance with the essential requirements and other relevant provisions of Directive 2014/53/EU (RED) and 2011/65/EU (RoHS). You will be able to find a copy of the original declaration of conformity at the following Internet address: <https://www.saltosystems.com/certificate>

ES Por medio de la presente SALTO Systems S.L. (Arkotz Kalea (Pol. Lanbarren), 9 – 20180 Oiartzun– Spain) declara que este equipo de control de accesos cumple con los requisitos esenciales y cualesquiera otras disposiciones aplicables o exigibles de la Directiva 2014/53/UE (RED) y 2011/65/UE (RoHS). Podrá encontrar una copia de la declaración de conformidad original en la siguiente dirección de internet: <https://www.saltosystems.com/certificate>

FR Par la présente SALTO Systems S.L. (Arkotz Kalea (Pol. Lanbarren), 9 – 20180 Oiartzun– Spain) déclare que l'appareil équipement pour le contrôle d'accès est conforme aux exigences essentielles et aux autres dispositions pertinentes de la directive 2014/53/UE (RED) et 2011/65/UE (RoHS). Vous pouvez télécharger une copie de la déclaration de conformité originale à travers l'adresse suivante: <https://www.saltosystems.com/certificate>

DE Hiermit erklärt SALTO Systems S.L. (Arkotz Kalea (Pol. Lanbarren), 9-20180 Oiartzun-Spain) dass sich das Gerät Zutrittskontrollgeräte im Übereinstimmung mit den grundlegenden Anforderungen und den übrigen einschlägigen Bestimmungen der Richtlinie 2014/53/EU (RED) befindet und 2011/65/EU (RoHS). Eine Kopie der originalen Konformitätserklärung finden Sie auf der folgenden Internetseite: <https://www.saltosystems.com/certificate>

NL Hierbij verklaart SALTO Systems S.L. (Arkotz Kalea (Pol. Lanbarren), 9 – 20180 Oiartzun– Spain) dat het toestel toegangscontroleapparatuur in overeenstemming is met de essentiële eisen en de andere relevante bepalingen van richtlijn 2014/53/EU (RED) en 2011/65/EU (RoHS). U kunt een kopie van de originele verklaring van overeenstemming vinden op het volgende internetadres: <https://www.saltosystems.com/certificate>

PT A SALTO Systems S.L. declara que este equipamento de controlo de acessos está conforme os requisitos essenciais e outras disposições da Diretiva 2014/53/UE (RED) e 2011/65/UE (RoHS). Poderá encontrar uma cópia da declaração de conformidade original na seguinte direção de internet: <https://www.saltosystems.com/certificate>

(B) EU DECLARATION OF CONFORMITY

EN Hereby, SALTO Systems S.L. (Arkotz Kalea (Pol. Lanbarren), 9 – 20180 Oiartzun– Spain), declares that this access control equipment is in compliance with the essential requirements and other relevant provisions of Directive 2014/30/EU (EMCD), 2014/35/EU (LVD) and 2011/65/EU (RoHS). You will be able to find a copy of the original declaration of conformity at the following Internet address: <https://www.saltosystems.com/certificate>

ES Por medio de la presente SALTO Systems S.L. (Arkotz Kalea (Pol. Lanbarren), 9 – 20180 Oiartzun– Spain) declara que este equipo de control de accesos cumple con los requisitos esenciales y cualesquiera otras disposiciones aplicables o exigibles de la Directiva 2014/30/UE (EMCD), 2014/35/UE (LVD) y 2011/65/UE (RoHS). Podrá encontrar una copia de la declaración de conformidad original en la siguiente dirección de internet: <https://www.saltosystems.com/certificate>

FR Par la présente SALTO Systems S.L. (Arkotz Kalea (Pol. Lanbarren), 9 – 20180 Oiartzun– Spain) déclare que l'appareil équipement pour le contrôle d'accès est conforme aux exigences essentielles et aux autres dispositions pertinentes de la directive 2014/30/UE (EMCD), 2014/35/UE (LVD) et 2011/65/UE (RoHS). Vous pouvez télécharger une copie de la déclaration de conformité originale à travers l'adresse suivante: <https://www.saltosystems.com/certificate>

DE Hiermit erklärt SALTO Systems S.L. (Arkotz Kalea (Pol. Lanbarren), 9-20180 Oiartzun-Spain) dass sich das Gerät Zutrittskontrollgeräte im Übereinstimmung mit den grundlegenden Anforderungen und den übrigen einschlägigen Bestimmungen der Richtlinie 2014/30/EU (EMCD), 2014/35/EU (LVD) befindet und 2011/65/EU (RoHS). Eine Kopie der originalen Konformitätserklärung finden Sie auf der folgenden Internetseite: <https://www.saltosystems.com/certificate>

NL Hierbij verklaart SALTO Systems S.L. (Arkotz Kalea (Pol. Lanbarren), 9 – 20180 Oiartzun– Spain) dat het toestel toegangscontroleapparatuur in overeenstemming is met de essentiële eisen en de andere relevante bepalingen van richtlijn 2014/30/EU (EMCD), 2014/35/EU (LVD) en 2011/65/EU (RoHS). U kunt een kopie van de originele verklaring van overeenstemming vinden op het volgende internetadres: <https://www.saltosystems.com/certificate>

PT A SALTO Systems S.L. declara que este equipamento de controlo de acessos está conforme os requisitos essenciais e outras disposições da Diretiva 2014/30/UE (EMCD), 2014/35/UE (LVD) e 2011/65/UE (RoHS). Poderá encontrar uma cópia da declaração de conformidade original na seguinte direção de internet: <https://www.saltosystems.com/certificate>

ELECTRICAL WARNINGS

EN **Caution:**

- Risk of explosion if battery is replaced by an incorrect type. Dispose of used batteries according to the instructions.
- Disposal of a battery into fire or a hot oven, or mechanically crushing or cutting of a battery, can result in an explosion.
- Leaving a battery in an extremely high temperature surrounding environment can result in an explosion or the leakage of flammable liquid or gas.
- A battery subjected to extremely low air pressure may result in an explosion or the leakage of flammable liquid or gas.

Distance between this device and human body must be higher than 20 cm.

FR **Attention:**

- Risque d'explosion si la pile est remplacée par un type de pile inadéquat. Jetez les piles usagées conformément aux instructions.
- La destruction d'une pile par le feu ou dans un four à haute température, le broyage ou encore son découpage mécanique peut entraîner une explosion.
- Laisser une pile dans un environnement où la température est extrêmement élevée peut entraîner une explosion, une fuite de liquide ou de gaz inflammable.
- Une pile soumise à une pression d'air extrêmement faible peut entraîner une explosion, ou la fuite d'un liquide ou d'un gaz inflammable.

La distance entre cet appareil et le corps humain doit être supérieure à 20 cm.

Recommended batteries:



- Duracell Plus Power (AAA) LR03 MN2400
- Duracell Ultra Power (AAA) LR03 MX2400
- Varta Industrial (AAA) LR03 04003
- Varta High Energy (AAA) LR03 04903
- Varta Max Tech (AAA) LR03 MN2400
- Duracell Ultra Power (AAA) LR03 MX1500
- Duracell Plus Power (AA) LR6 MN1500
- Varta Industrial (AA) LR6 04006
- Varta High Energy (AA) LR6 04906
- Varta Max Tech (AA) LR6 MN1500

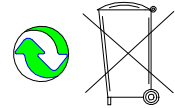

MECHANICAL WARNINGS

In order to confirm the correct operation of this electronic device, SALTO recommends using it in combination with a lock destined for that use (door mass, frequency of use, fire door, etc.) and that is in good operational conditions. Polished finishes are strongly recommended in seaside environments for a better performance and durability. The environmental conditions mentioned in the data sheets are always referred to non-condensation situations. The Biocote and IA finishes are painted and sharp objects such as rings or metallic key rings or other metallic objects should be avoided during any cleaning process. The SALTO product should be treated with care during the installation process to avoid any aggressive contact that may damage the unit. It may be necessary to loosen the trims mounting during installation. Do not bring the device into contact with oil, paints or acids. Do not paint the door with the mortise lock or electronic device already mounted on the door. CLEANING THE ELECTRONIC DEVICE: a damp cloth with mild soapy water can be used.

Never use abrasive soaps or sprays. The black chromium finish ("NE" code) is coated with a protective oil that improves the product conservation. Its presence may increase the appearance of fingerprint traces after the needed product handling. Thus, no cleaning processes are applied at the origin to avoid removing the protective layer. SALTO recommends cleaning the product surfaces with a damp cloth after its manipulation when the installation is finished. For best performance, stainless steel should be cleaned regularly. Note that when the door is closed without the lock having been already programmed, the lock will automatically lock and can only be opened with a Portable Programming Device (PPD). If you have questions or doubts on this, please contact your authorized SALTO supplier.

LEGAL WARNINGS

The user shall be responsible for the correct use and maintenance of the access control equipment according to the instructions herein. SALTO shall not be responsible for any defect, malfunction, loss or damage, whether direct or indirect, caused by or arisen from any improper installation or utilization of the equipment or which contravenes, transgresses or infringes in any manner the above mentioned instructions. SALTO's liability concerning the equipment is limited to the warranty provided. The warranty does not cover product failures due to repairs, modifications or product manipulations performed in the access control equipment or in the inner electromechanical structure by anyone other than authorized SALTO dealers or personnel.



FCC COMPLIANCE STATEMENT (1)

This device complies with Part 15 of the FCC Rules. Operation is subject to the following two conditions: (1) this device may not cause harmful interference, and (2) this device must accept any interference received, including interference that may cause undesired operation. Changes or modifications not expressly approved by the party responsible for compliance could void the user's authority to operate the equipment.

Note: This equipment has been tested and found to comply with the limits for a Class B digital device, pursuant to part 15 of the FCC Rules. These limits are designed to provide reasonable protection against harmful interference in a residential installation. This equipment generates, uses, and can radiate radio frequency energy and, if not installed and used in accordance with the instructions may cause harmful interference to radio communications. However, there is no guarantee that interference will not occur in a particular installation. If this equipment does cause harmful interference to radio or television reception, which can be determined by turning the equipment off and on, the user is encouraged to try to correct the interference by one or more of the following measures:

- Reorient or relocate the receiving antenna.
- Increase the separation between the equipment and receiver.
- Connect the equipment into an outlet on a circuit different from that to which the receiver is connected.
- Consult the dealer or an experienced radio/TV technician for help.

This product is a radio transmitter and receiver to be used in **mobile** conditions.

Supplier's Declaration of Conformity

47 CFR § 2.1077 Compliance Information

We, SALTO Systems, S.L., hereby declare that the equipment bearing the model number specified above was tested conforming to the applicable FCC Rules.

Responsible Party – U.S. Contact Information

Salto Systems Inc. USA. 1780 Corporate Drive, Suite 400. Norcross, GA. 30093. I.saldana@saltosystems.com



ISED COMPLIANCE STATEMENT (2)

This device complies with Industry Canada license-exempt RSS standard(s). Operation is subject to the following two conditions: (1) this device may not cause harmful interference, and (2) this device must accept any interference received, including interference that may cause undesired operation. Changes or modifications not expressly approved by the party responsible for compliance could void the user's authority to operate the equipment.

Le présent appareil est conforme aux CNR d'Industrie Canada applicables aux appareils radio exempts de licence. L'exploitation est autorisée aux deux conditions suivantes: (1) l'appareil ne doit pas produire de brouillage, et (2) l'utilisateur de l'appareil doit accepter tout brouillage radioélectrique subi, même si le brouillage est susceptible d'en compromettre le fonctionnement.

This device has been tested and found to comply with the limits for a Class B digital device, pursuant to ICES-003.

MIC COMPLIANCE STATEMENT (3)

注意) 本装置は、FCC規則パート15 クラスA、日本のZigbee規格及びEMC規格VCCI クラスAに準拠しています。本装置の動作は、次の二つの条件を満たす必要があります：(1) 本装置は、有害な電波干渉を発生させない。(2) 本装置は、望ましくない動作を引き起こす可能性のある電波干渉も含め、受信したいかなる電波干渉にも耐えうるものでなければならない。注意) 本装置は、日本のVCCIクラスAに相当するFCC規則パート15に準拠したクラスAデジタル装置の許容値に準拠しています。これらの制限は、本装置を商業地域で運用する場合に限り、電波障害に対する適切な保護措置が行われるように設計されています。本装置は電波エネルギーを発生、使用、放射し、ユーザーズマニュアルに従って設置、使用しない場合は無線装置に干渉する可能性もあります。本装置を住宅地域で使用する場合、有害な干渉を起こす可能性があり、その場合ユーザーは自身の費用負担で干渉防止対策を講じることを求められます。

RF2MODULEのユーザーマニュアルは、次のインターネットアドレスでご覧いただけます。https://www.saltosystems.com/certificate

IMDA COMPLIANCE LABEL (4)



NCC WARNING STATEMENT / NCC 警語要求 (5)

取得審験證明之低功率射頻器材，非經核准，公司、商號或使用者均不得擅自變更頻率、加大功率或變更原設計之特性及功能。低功率射頻器材之使用不得影響飛航安全及干擾合法通信；經發現有干擾現象時，應立即停用，並改善至無干擾時方得繼續使用。前述合法通信，指依電信管理法規定作業之無線電通信。低功率射頻器材須忍受合法通信或工業、科學及醫療用電波輻射性電機設備之干擾。

Legend:

	Remarks:
(1) FCC	Not applicable for models W08, W08W
(2) ISED	Not applicable for models W08, W08W
(3) MIC	Not applicable for W08, W08W, W40M, W60M, W80M, W02
(4) IMDA	Not applicable for W08, W08W, W40M, W60M, W80M, W02
(5) NCC	Not applicable for models W09, W0S, W09W, W0BW, W0JW, W08, W08W, W0SK, W0BWK, W0JWK, W40M, W60M, W80M, W02