

ISED CABid: ES1909

Test Report No:

Lab. Company Number: 4621A

74431RRF.002

Test Report

USA FCC Part 15.225, 15.209

CANADA RSS-210, RSS-Gen

(*) Identification of item tested	Smart ESD
(*) Trademark	SALTO
(*) Model and/or type reference	ESD9 (Type reference: P1010)
Other identification of the product	FCC ID: UKCESD9 IC: 10088A-ESD9
(*) Features	Features: Two relays, L1 and L2 HW version: 1.0 SW version: 0010 (Control FW)
Applicant	SALTO SYSTEMS, S.L. Arkotz 9, Polígono Lanbarren 20180, Oiartzun, Gipuzkoa, SPAIN
Test method requested, standard	USA FCC Part 15.225 (10-1-21 Edition): Operation within the band 13.110 -14.010. USA FCC Part 15.209 (10-1-21 Edition): Radiated emission limits, general requirements. CANADA RSS-210 Issue 10 (December 2019). CANADA RSS-Gen Issue 5 (March 2019). ANSI C63.10-2013: American National Standard for Testing Unlicensed Wireless Devices.
Summary	IN COMPLIANCE
Approved by (name / position & signature)	José Manuel Gómez Galván EMC Consumer & RF Lab. Manager
Date of issue	2023-05-03
Report template No	FDT08_24 (* "Data provided by the client")

Index

Competences and guarantees	3
General conditions.....	3
Uncertainty.....	3
Data provided by the client	4
Usage of samples	4
Test sample description.....	5
Identification of the client	6
Testing period and place	6
Document history.....	6
Environmental conditions	6
Remarks and comments.....	7
Testing verdicts.....	8
Summary	8
Appendix A: Test results.....	9

Competences and guarantees

DEKRA Testing and Certification S.A.U. is a testing laboratory accredited by the National Accreditation Body (ENAC -Entidad Nacional de Acreditación), to perform the tests indicated in the Certificate No. 51/LE 147.

DEKRA Testing and Certification S.A.U. is an FCC-recognized accredited testing laboratory with appropriate scope of accreditation that covers the performed tests in this report.

DEKRA Testing and Certification S.A.U. is an ISED-recognized accredited testing laboratory, CABid: ES1909, Company Number: 4621A, with the appropriate scope of accreditation that covers the performed tests in this report.

In order to assure the traceability to other national and international laboratories, DEKRA Testing and Certification has a calibration and maintenance program for its measurement equipment.

DEKRA Testing and Certification guarantees the reliability of the data presented in this report, which is the result of the measurements and the tests performed to the item under test on the date and under the conditions stated on the report and, it is based on the knowledge and technical facilities available at DEKRA Testing and Certification at the time of performance of the test.

DEKRA Testing and Certification is liable to the client for the maintenance of the confidentiality of all information related to the item under test and the results of the test.

The results presented in this Test Report apply only to the particular item under test established in this document.

IMPORTANT: No parts of this report may be reproduced or quoted out of context, in any form or by any means, except in full, without the previous written permission of DEKRA Testing and Certification.

General conditions

1. This report is only referred to the item that has undergone the test.
2. This report does not constitute or imply on its own an approval of the product by the Certification Bodies or competent Authorities.
3. This document is only valid if complete; no partial reproduction can be made without previous written permission of DEKRA Testing and Certification.
4. This test report cannot be used partially or in full for publicity and/or promotional purposes without previous written permission of DEKRA Testing and Certification and the Accreditation Bodies.

Uncertainty

Uncertainty (factor $k=2$) was calculated according to the DEKRA Testing and Certification internal document PODT000.

The total uncertainty of the measurement system for the radiated emissions of EUT from 9 kHz to 30 MHz is:
Measurement uncertainty $\leq \pm 3.08$ dB (with factor $k = 2$).

The total uncertainty of the measurement system for the radiated emissions of EUT from 30 MHz to 200 MHz is:
Measurement uncertainty $\leq \pm 5.35$ dB (with factor $k = 2$).

The total uncertainty of the measurement system for the conducted testing of EUT is:
Frequency Tolerance of the Carrier Signal: Measurement uncertainty $\leq \pm 12.3$ kHz
Occupied Bandwidth $\leq \pm 1.70$ kHz
Field strength of emissions within the band $\leq \pm 3.44$ dB

Data provided by the client

The following data has been provided by the client:

1. Information relating to the description of the sample ("Identification of the item tested", "Trademark", "Model and/or type reference tested").
2. The sample consists of a Smart Energy Saving Device (ESD) with RFID Mifare (ISO 14443A standard based).

DEKRA Testing and Certification S.A.U. declines any responsibility with respect to the information provided by the client and that may affect the validity of results.

Usage of samples

Samples undergoing test have been selected by: The client.

Id	Control Number	Description	Model	Serial N°	Date of Reception	Application
S/01	74431_17.1	Smart ESD	ESD9	--	2023-04-10	Element Under Test

Notes referenced to samples during the project:

Id	Type
S/01	Sample used for testing

Test sample description

Ports..... :	Port name and description	Cable					
		Specified max length [m]	Attached during test	Shielded	Coupled to patient ⁽³⁾		
	L1	100 m	[X]	[]	[]		
	L2	100 m	[X]	[]	[]		
	--		[]	[]	[]		
Supplementary information to the ports..... :							
Rated power supply	Voltage and Frequency		Reference poles				
			L1	L2	L3	N	PE
	[X]	AC: 85-265 Vac, 50/60 Hz	[]	[]	[]	[]	[]
[]	DC:						
Rated Power	--						
Clock frequencies	4.91 MHz, 13.56 MHz						
Other parameters..... :	Two relays, L1 and L2						
Software version	0010 (Control FW)						
Hardware version..... :	1.0						
Dimensions in cm (W x H x D).... :	8.2 x 14 x 3.15						
Mounting position..... :	[]	Table top equipment					
	[X]	Wall/Ceiling mounted equipment					
	[]	Floor standing equipment					
	[]	Hand-held equipment					
	[]	Other:					
Modules/parts	Module/parts of test item		Type	Manufacturer			
	--						
Accessories (not part of the test item)	Description		Type	Manufacturer			
	--						
Documents as provided by the applicant..... :	Description		File name	Issue date			
	User Manual						
	FW Explanation Document						
	--						

⁽³⁾ Only for Medical Equipment

Identification of the client

SALTO SYSTEMS, S.L.
Arkotz 9, Polígono Lanbarren
20180, Oiartzun, Gipuzkoa, SPAIN

Testing period and place

Test Location	DEKRA Testing and Certification S.A.U.
Date (start)	2023-03-28
Date (finish)	2023-04-17

Document history

Report number	Date	Description
74431RRF.002	2023-05-03	First release.

Environmental conditions

In the control chamber, the following limits were not exceeded during the test:

Temperature	Min. = 15 °C Max. = 35 °C
Relative humidity	Min. = 20 % Max. = 75 %

In the semianechoic chamber, the following limits were not exceeded during the test.

Temperature	Min. = 15 °C Max. = 35 °C
Relative humidity	Min. = 20 % Max. = 75 %

In the chamber for conducted measurements, the following limits were not exceeded during the test:

Temperature	Min. = 15 °C Max. = 35 °C
Relative humidity	Min. = 20 % Max. = 75 %

Remarks and comments

The tests have been performed by the technical personnel: Rafael Fernandez.

Used instrumentation:

Control No.	Equipment	Model	Manufacturer	Next Calibration
6791	SEMIANECHOIC ABSORBER LINED CHAMBER	FACT 3 200 STP	ETS LINDGREN	N/A
6792	SHIELDED ROOM	S101	ETS LINDGREN	N/A
0242	ACTIVE LOOP ANTENNA 9 KHZ-30 MHz	11966A	HEWLETT PACKARD	2024-08-18
6165	EMI TEST RECEIVER 9kHz-7GHz	ESR7	ROHDE AND SCHWARZ	2023-11-08
6143	HYBRID BILOG ANTENNA 30MHz-6GHz	3142E	ETS LINDGREN	2023-10-29
6142	PRE-AMPLIFIER G>38dB 30MHz-6GHz	BLNA 0360-01N	BONN ELEKTRONIK	2023-06-16
7817	EMI TEST RECEIVER 2Hz-44GHz	ESW44	ROHDE AND SCHWARZ	2023-12-30
6793	SHIELDED ROOM	S101	ETS LINDGREN	N/A
1452	THREE-PHASE POWER SOURCE 6kVA	360AMXT-UPC32	PACIFIC POWER SOURCE	N/A
7760	DIGITAL MULTIMETER	175	FLUKE	2023-11-14
8002	TEMPERATURE CHAMBER	MK 56	BINDER	2023-03-22

Testing verdicts

Fail	F
Inconclusive	I
Not applicable	N/A
Not measured	N/M
Pass	P

Summary

FCC PART 15 PARAGRAPH / RSS-210		
Requirement – Test case	Verdict	Remark
FCC 15.225 (a) / RSS-210 B.6 (a)(i) Field strength of emissions within the band 13.553 MHz -13.567 MHz	P	--
FCC 15.225 (b) / RSS-210 B.6 (a)(ii) Field strength of emissions within the band 13.410 - 13.553 MHz and 13.567 – 13.710 MHz	P	--
FCC 15.225 (c) / RSS-210 B.6 (a)(iii) Field strength of emissions within the band 13.110 - 13.410 MHz and 13.710 – 14.010 MHz	P	--
FCC 15.225 (d) / RSS-210 B.6 (a)(iv) Field strength of emissions outside of the band 13.110 MHz -14.010 MHz	P	--
FCC 15.225 (e) / RSS-210 B.6 (b) Frequency tolerance of the carrier signal	P	--
<u>Supplementary information and remarks:</u> None.		

Appendix A: Test results

INDEX

TEST CONDITIONS	11
Occupied Bandwidth	14
FCC 15.225 (a) / RSS-210 B.6 (a). Field strength of emissions within the band 13.553 -13.567 MHz	15
FCC 15.225 (b) / RSS-210 B.6 (b). Field strength of emissions within the band 13.410 - 13.553 MHz and 13.567 - 13.710 MHz	16
FCC 15.225 (c) / RSS-210 B.6 (c). Field strength of emissions within the band 13.110 - 13.410 MHz and 13.710 - 14.010 MHz.....	18
FCC 15.225 (d) / RSS-210 B.6 (a)(iv) Field Strength of Emissions outside of the band 13.110 MHz - 14.010 MHz	20
FCC 15.225 (e) / RSS-210 B.6 (b) Frequency Tolerance of the Carrier Signal	23

TEST CONDITIONS

(*) Data provided by the Applicant.

POWER SUPPLY (*):

Vnominal:	115Vac
Vminimum:	97.75Vac
Vmaximum:	132.25Vac
Type of Power Supply:	External power supply

ANTENNA (*):

Type of Antenna:	Integral, PCB.
Maximum Declared Antenna Gain:	N/A

TEST FREQUENCY (*):

Nominal Operating Frequency: 13.56 MHz

CONDUCTED MEASUREMENTS:

The equipment under test was set up in a shielded room and it is directly connected to the spectrum analyzer.

For frequency stability test the EUT was placed inside a climatic chamber and connected to a frequency meter using a low loss cable. An external DC power supply was connected to the EUT for voltage variation test.

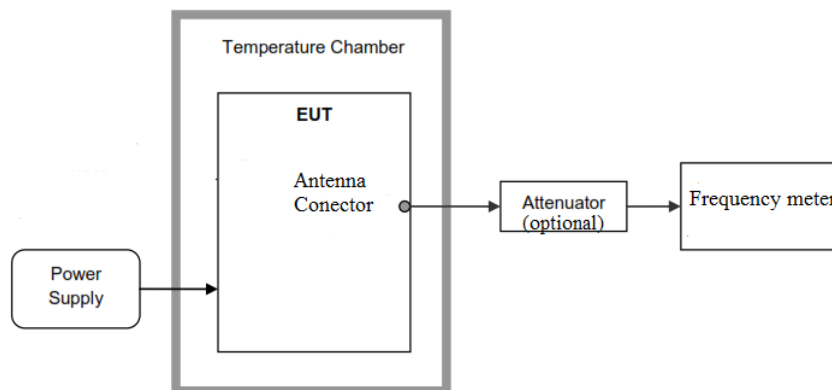

RADIATED MEASUREMENTS:

All radiated tests were performed in a semi-anechoic chamber. The measurement antenna (Loop antenna for the range between 9 kHz to 30 MHz and Bilog antenna for the range between 30 MHz to 200 MHz) is situated at a distance of 3 m.

For radiated emissions in the range 9 kHz to 30 MHz that is performed at a distance closer than the specified distance, an inverse proportionality factor of 40 dB per decade is used to normalize the measured data for determining compliance.

The equipment under test was set up on a non-conductive platform above the ground plane and the situation and orientation was varied to find the maximum radiated emission. It was also rotated 360° and in the range between 30 MHz and 200 MHz the antenna height was varied from 1 to 4 meters to find the maximum radiated emission. In the range between 9 kHz and 30 MHz the measurements were made in the three different orientation planes of the loop antenna to determine the maximum received field. In the range between 30 MHz and 200 MHz the measurements were made in both horizontal and vertical planes of polarization.

Radiated measurements setup 9 kHz to 30 MHz:

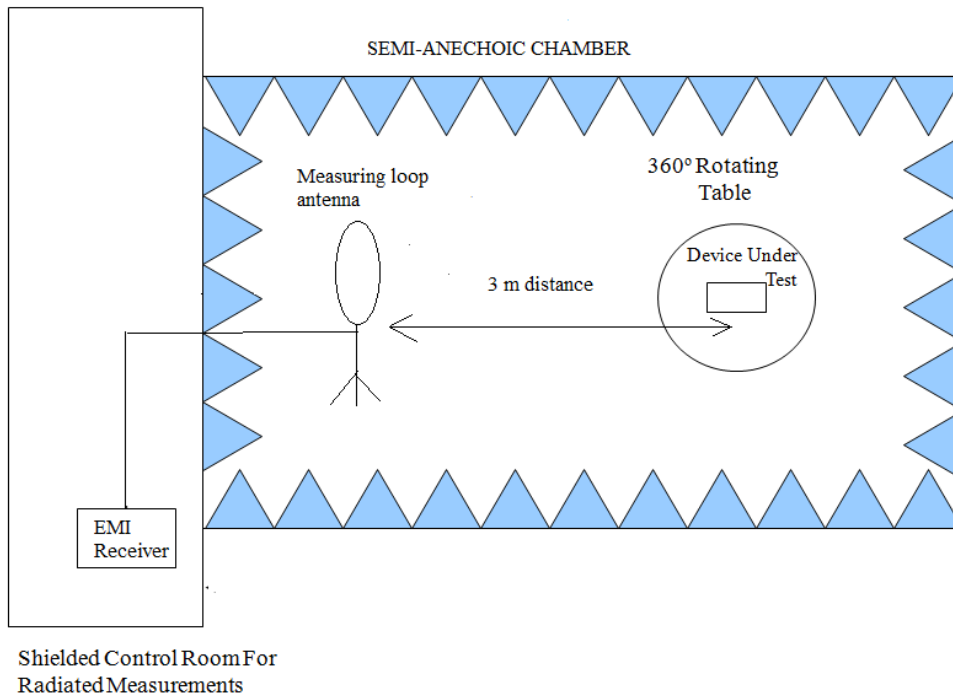

Radiated measurements setup 30 MHz to 200 MHz:

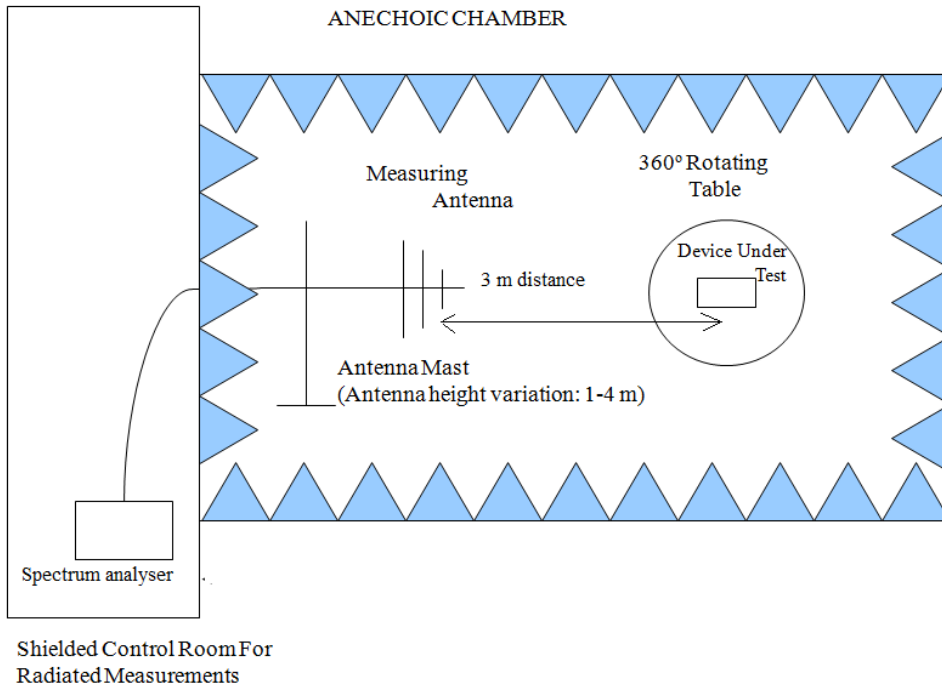

Occupied Bandwidth

RESULTS:

99 % Occupied Bandwidth and 20 dB Bandwidth.

- **RFID mode ISO 1443A:**

Operation mode	99% Occupied Bandwidth (kHz)	20 dB Bandwidth (kHz)
RFID 13.56 MHz mode ISO 1443A	1093.6	380.2

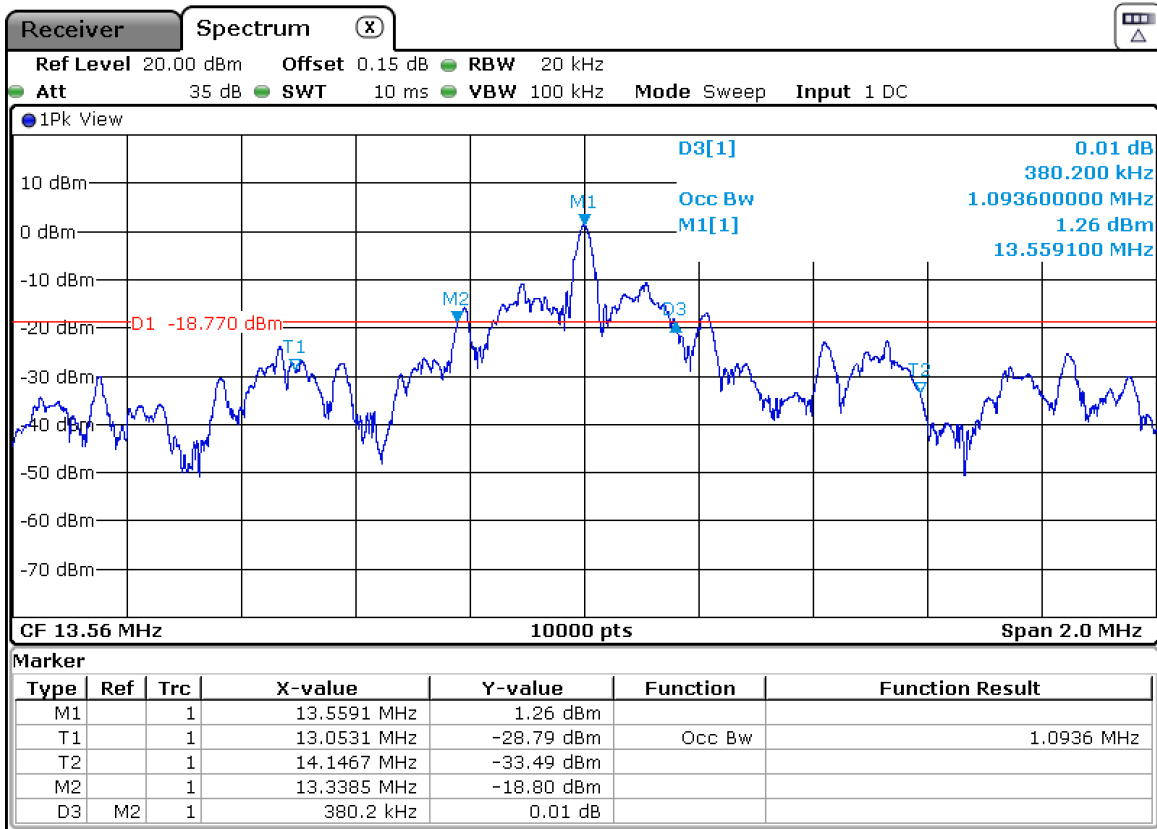

FCC 15.225 (a) / RSS-210 B.6 (a). Field strength of emissions within the band 13.553 -13.567 MHz

SPECIFICATION:

The field strength of any emissions within the band 13.553 – 13.567 MHz shall not exceed 15,848 microvolts/meter (84 dBµV/m) at 30 meters.

RESULTS:

Measurement distance: 3 meters.

- **RFID mode ISO 14443A:**

The maximum field strength of fundamental emission:

Frequency (MHz)	Maximum field strength (dBµV/m) measured at 3 m (quasi-peak detector)	Maximum field strength (dBµV/m) extrapolated to 30 m (40 dB/decade)
13.561	53.15	13.15

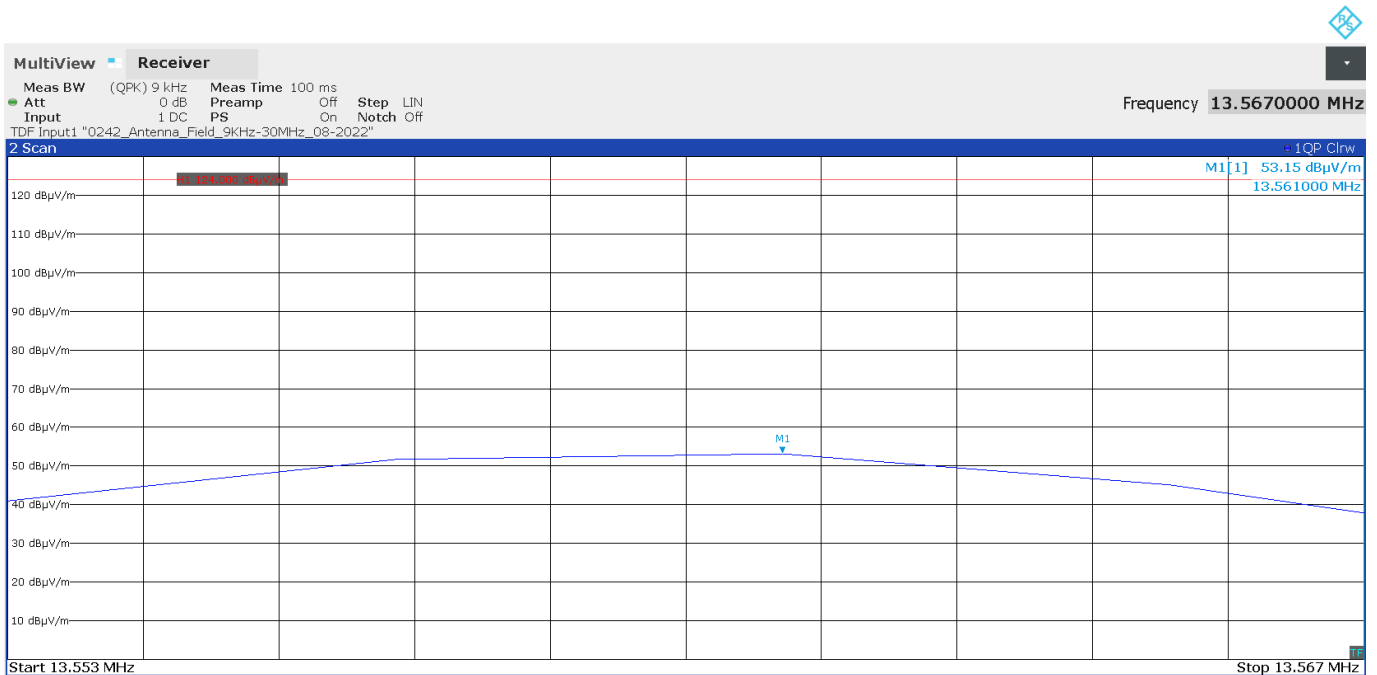

The limit shown in the above plot is extrapolated to 3 meters

Verdict: PASS

FCC 15.225 (b) / RSS-210 B.6 (b). Field strength of emissions within the band 13.410 - 13.553 MHz and 13.567 - 13.710 MHz

SPECIFICATION:

Within the bands 13.410-13.553 MHz and 13.567-13.710 MHz, the field strength of any emissions shall not exceed 334 microvolts/meter (50.47 dBµV/m) at 30 meters.

RESULTS:

Measurement distance: 3 meters.

- Band 13.410 - 13.553 MHz

- **RFID mode ISO 14443A:**

Frequency (MHz)	Maximum field strength (dBµV/m) measured at 3 m (quasi-peak detector)	Maximum field strength (dBµV/m) extrapolated to 30 m (40 dB/decade)
13.553	40.99	0.99

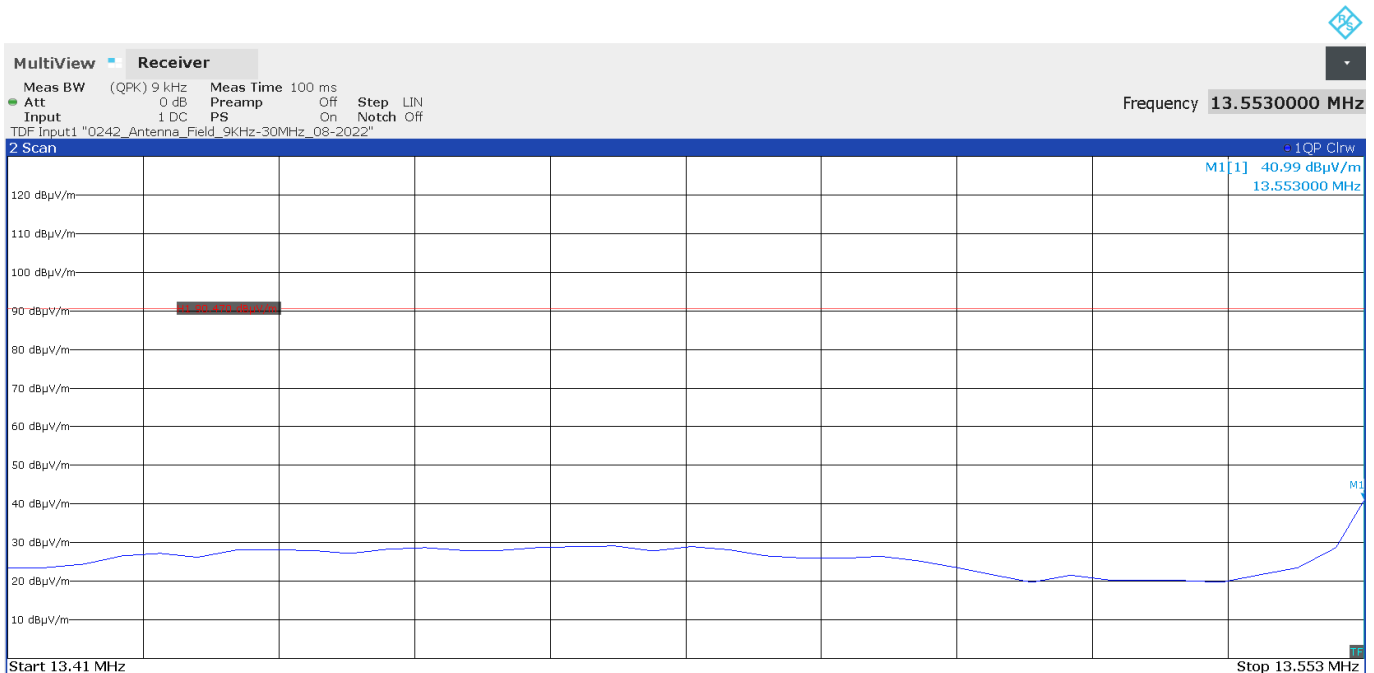

The limit shown in the above plot is extrapolated to 3 meters

Verdict: PASS

- Band 13.567-13.710 MHz

- **RFID mode ISO 14443A:**

Frequency (MHz)	Maximum field strength (dBµV/m) measured at 3 m (quasi-peak detector)	Maximum field strength (dBµV/m) extrapolated to 30 m (40 dB/decade)
13.567	37.91	-2.09

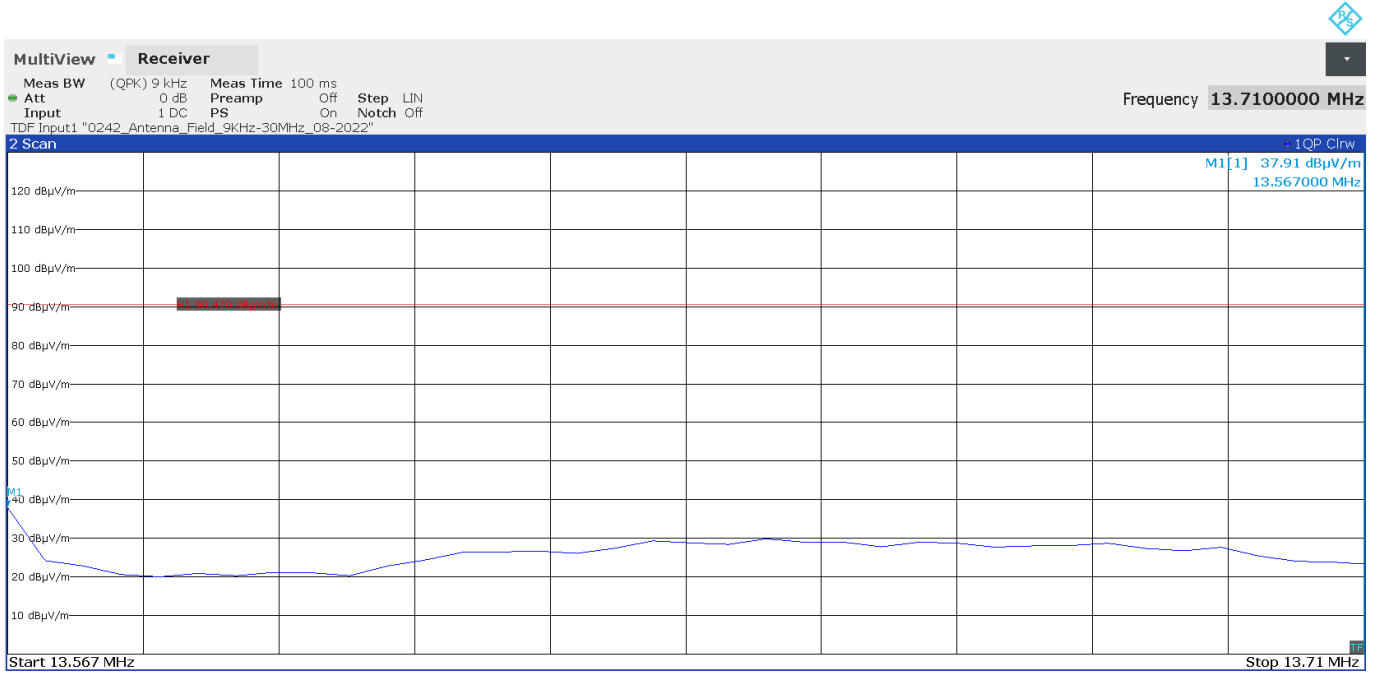

The limit shown in the above plot is extrapolated to 3 meters

Verdict: PASS

FCC 15.225 (c) / RSS-210 B.6 (c). Field strength of emissions within the band 13.110 - 13.410 MHz and 13.710 - 14.010 MHz

SPECIFICATION:

Within the bands 13.110-13.410 MHz and 13.710-14.010 MHz, the field strength of any emissions shall not exceed 106 microvolts/meter (40.51 dBµV/m) at 30 meters.

RESULTS:

Measurement distance: 3 meters.

- Band 13.110-13.410 MHz

- **RFID mode ISO 14443A:**

Frequency (MHz)	Maximum field strength (dBµV/m) measured at 3 m (quasi-peak detector)	Maximum field strength (dBµV/m) extrapolated to 30 m (40 dB/decade)
13.350	31.28	-8.72

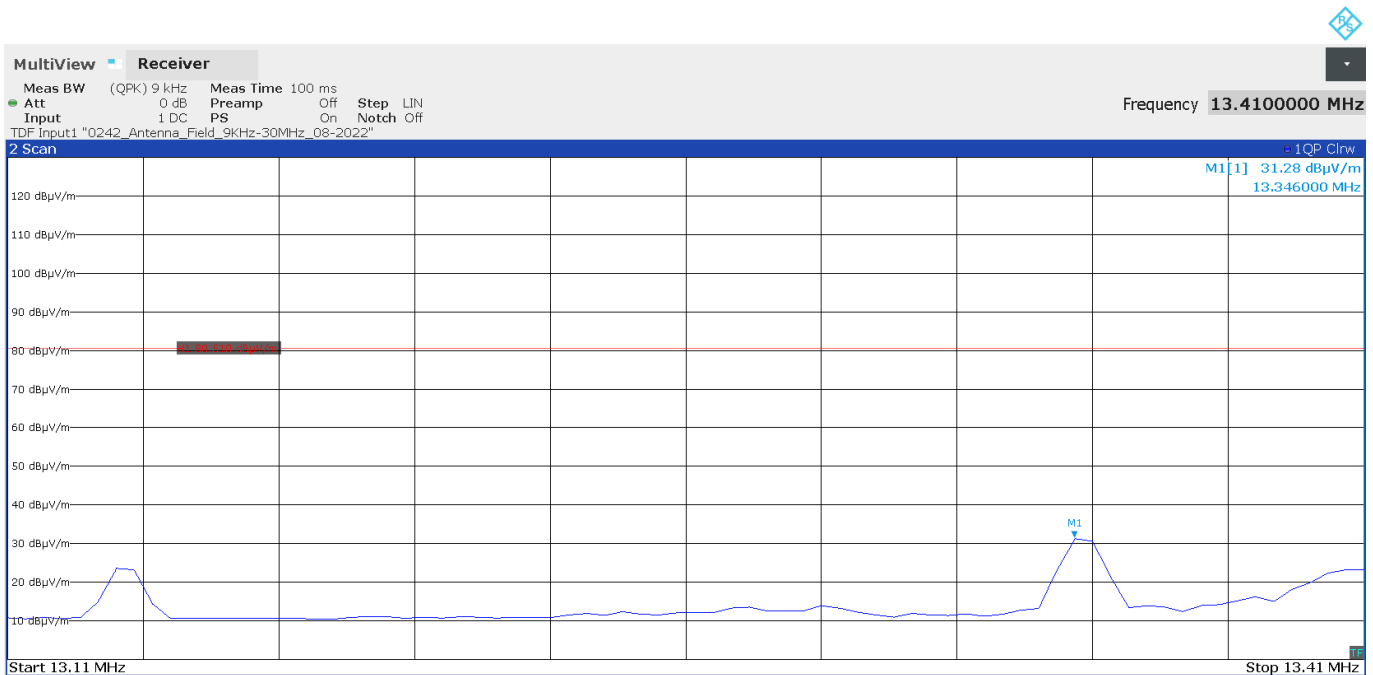

The limit shown in the above plot is extrapolated to 3 meters

Verdict: PASS

- Band 13.710-14.010 MHz

- **RFID mode ISO 14443A:**

Frequency (MHz)	Maximum field strength (dBµV/m) measured at 3 m (quasi-peak detector)	Maximum field strength (dBµV/m) extrapolated to 30 m (40 dB/decade)
13.774	31.98	-8.02

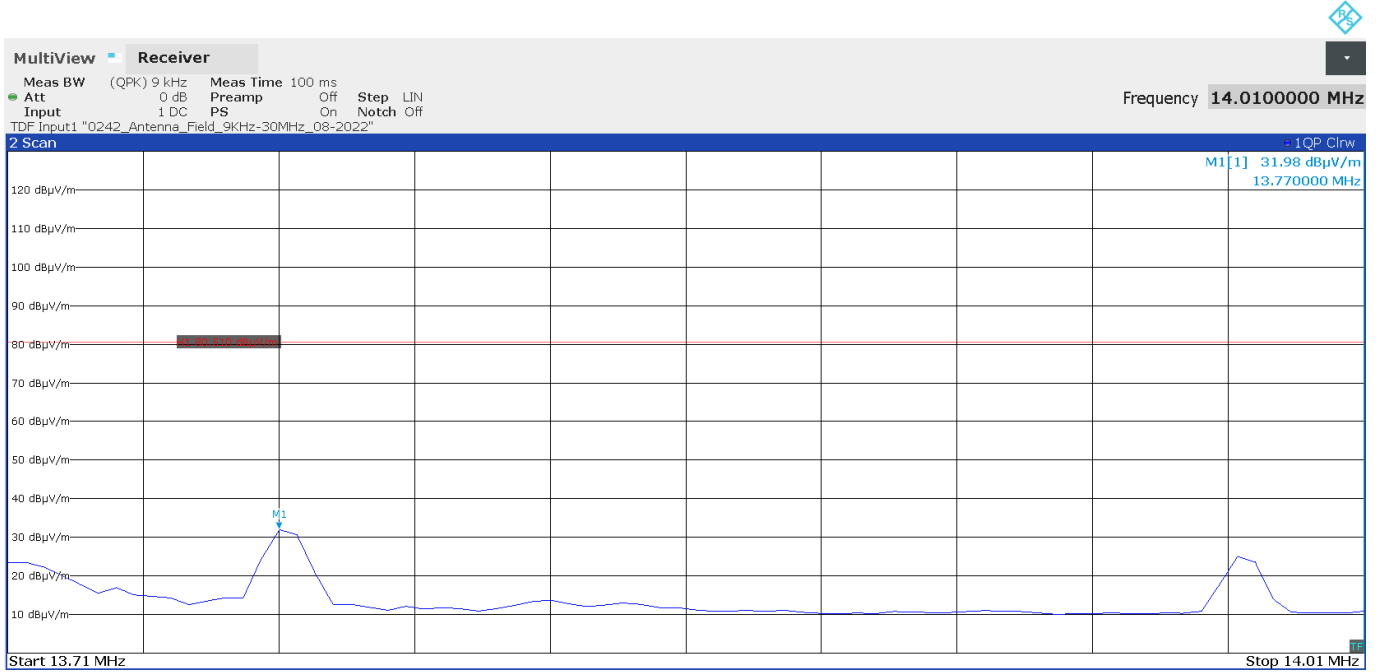

The limit shown in the above plot is extrapolated to 3 meters

Verdict: PASS

FCC 15.225 (d) / RSS-210 B.6 (a)(iv) Field Strength of Emissions outside of the band 13.110 MHz - 14.010 MHz

SPECIFICATION:

Field strength of any emissions appearing outside of the band 13.110 MHz - 14.010 MHz band shall not exceed the general radiated emission limits in 15.209/RSS-Gen:

Frequency Range (MHz)	Field strength ($\mu\text{V/m}$)	Field strength ($\text{dB}\mu\text{V/m}$)	Measurement distance (m)
0.009-0.490	2400/F(kHz)	-	300
0.490-1.705	24000/F(kHz)	-	30
1.705 - 30.0	30	29.54	30
30 - 88	100	40	3
88 - 216	150	43.5	3
216 - 960	200	46	3
Above 960	500	54	3

RESULTS:

All tests were performed in a semi-anechoic chamber at a distance of 3 m.

The spectrum was inspected from 9 kHz to 200 MHz searching for spurious signals.

The field strength is calculated by adding correction factor to the measured level from the spectrum analyzer. This correction factor includes antenna factor, cable loss and pre-amplifier gain.

- Frequency range 9 kHz - 30 MHz:

- RFID mode ISO 14443A:

No spurious frequencies were found at less than 20 dB of the limit.

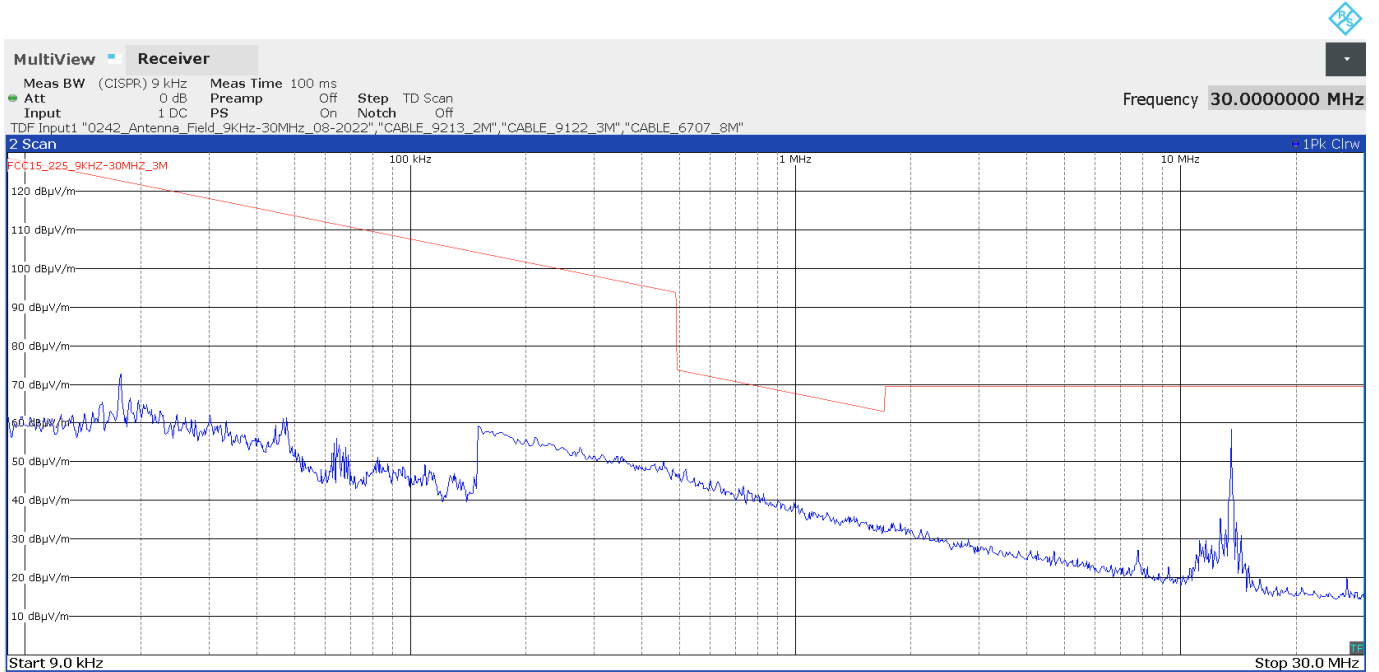

The limits shown in the above plot are extrapolated to 3 meters. The highest peak corresponds to the carrier level.

Resolution bandwidth:
200 Hz for $9 \text{ kHz} \leq f \leq 150 \text{ kHz}$
9 kHz for $150 \text{ kHz} \leq f \leq 30 \text{ MHz}$

- Frequency range 30 - 200 MHz:

- **RFID mode ISO 14443A:**

Spurious frequencies were found at less than 20 dB of the limit:

Spurious frequency (MHz)	Emission Level (dBµV/m)	Polarization	Detector
40.6788	30.1	V	Quasi peak
54.2541	28.3	V	Quasi peak
67.7795	31.9	V	Quasi peak
94.9202	22.5	V	Quasi peak
108.4748	32.2	V	Quasi peak
122.0238	25.6	V	Quasi peak
149.1574	33.8	V	Quasi peak
176.2765	22.0	V	Quasi peak

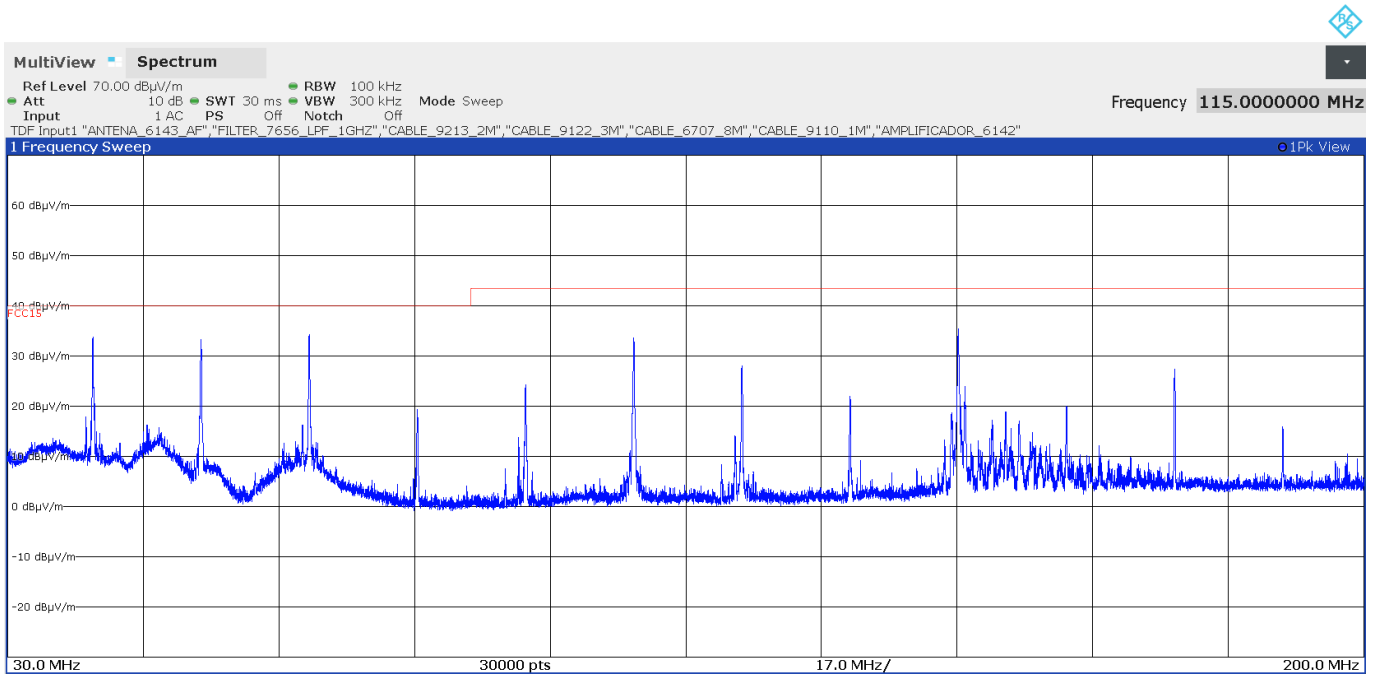

The above plot shows the results of the scan using peak detector.

Verdict: PASS

FCC 15.225 (e) / RSS-210 B.6 (b) Frequency Tolerance of the Carrier Signal

SPECIFICATION:

The frequency tolerance of the carrier signal shall be maintained within +/- 0.01% of the operating frequency over a temperature variation of -20 degrees to +50 degrees C at normal supply voltage, and for a variation in the primary supply voltage from 85% to 115% of the rated supply voltage at a temperature of 20 degrees C. For hand carried, battery powered equipment, reduce primary supply voltage to the battery operating end point which shall be specified by the manufacturer.

RESULTS:

Nominal Operating Frequency: 13.56 MHz.

- **RFID mode ISO 14443A:**

Frequency Stability over Temperature Variations:

Temperature (°C)	Frequency Error (kHz)	Frequency Error (%)
+50	0.525000	0.003872
+40	0.507000	0.003739
+30	0.475500	0.003507
+20	0.480000	0.003540
+10	0.495000	0.003650
0	0.469500	0.003462
-10	0.400500	0.002954
-20	0.417000	0.003075

Frequency Stability over Voltage Variations:

DC Voltage	Voltage (V)	Temperature (°C)	Frequency Error (kHz)	Frequency Error (%)
Vmax	132.25	20	0.457500	0.003374
Vmin	97.75	20	0.477000	0.003518

Verdict: PASS