



FCC LISTED, REGISTRATION
 NUMBER: 720267

ISED LISTED REGISTRATION
 NUMBER 4621A-2

Informe de ensayo nº:
 Test report No:

NIE: 53613RRF.005

Test report

REFERENCE STANDARD: USA FCC Part 15.225 and Part 15.209 & CANADA RSS-210

Identificación del objeto ensayado:	Electronic Lock Series including all mechanical variants
Identification of item tested	
Marca	AElement Fusion
Trademark	
Modelo y/o referencia tipo	AF0J (Type reference: E1723)
Model and /or type reference	
Other identification of the product	FCC ID: UKCAF0B IC: 10088A-AF0B
Final HW version	1.0
Final SW version	0145 (Control Firmware) + 0136 (BGM111 Firmware)
Características	Contains a certified Bluetooth module (BGM111)
Features	
Solicitante	SALTO Systems, S.L. Arkotz 9, Polígono Lanbarren 20180, Oiartzun, Gipuzkoa, SPAIN
Applicant	
Método de ensayo solicitado, norma:	USA FCC Part 15.225 (10–1–16 Edition): Operation within the band 13.110 -14.010. USA FCC Part 15.209 (10–1–16 Edition): Radiated emission limits, general requirements. CANADA RSS-210 Issue 9 (August 2016). CANADA RSS-Gen Issue 4 (November 2014). ANSI C63.10-2013: American National Standard for Testing Unlicensed Wireless Devices.
Test method requested, standard	
Resultado:	IN COMPLIANCE
Summary	
Aprobado por (nombre / cargo y firma)	A. Llamas RF Lab. Manager
Approved by (name / position & signature)	
Fecha de realización	2018-01-31
Date of issue	
Formato de informe No.:	FDT08_20
Report template No	

Index

Competences and guarantees.....	3
General conditions.....	3
Uncertainty	3
Usage of samples.....	4
Test sample description	4
Identification of the client	4
Testing period.....	4
Environmental conditions.....	4
Remarks and comments.....	5
Testing verdicts	6
Appendix A – Test result.....	7

Competences and guarantees

DEKRA Testing and Certification is a testing laboratory accredited by the National Accreditation Body (ENAC - Entidad Nacional de Acreditación), to perform the tests indicated in the Certificate No. 51/LE 147.

DEKRA Testing and Certification is a laboratory with a measurement facility in compliance with the requirements of Section 2.948 of the FCC rules and has been added to the list of facilities whose measurements data will be accepted in conjunction with applications for Certification under Parts 15 or 18 of the Commission's Rules. Registration Number: 720267.

DEKRA Testing and Certification is a laboratory with a measurement site in compliance with the requirements of RSS 212, Issue 1 (Provisional) and has been added to the list of filed sites of the Canadian Certification and Engineering Bureau. Reference File Number: ISED 4621A-2.

In order to assure the traceability to other national and international laboratories, DEKRA Testing and Certification has a calibration and maintenance program for its measurement equipment.

DEKRA Testing and Certification guarantees the reliability of the data presented in this report, which is the result of the measurements and the tests performed to the item under test on the date and under the conditions stated on the report and, it is based on the knowledge and technical facilities available at DEKRA Testing and Certification at the time of performance of the test.

DEKRA Testing and Certification is liable to the client for the maintenance of the confidentiality of all information related to the item under test and the results of the test.

The results presented in this Test Report apply only to the particular item under test established in this document.

IMPORTANT: No parts of this report may be reproduced or quoted out of context, in any form or by any means, except in full, without the previous written permission of DEKRA Testing and Certification.

General conditions

1. This report is only referred to the item that has undergone the test.
2. This report does not constitute or imply on its own an approval of the product by the Certification Bodies or competent Authorities.
3. This document is only valid if complete; no partial reproduction can be made without previous written permission of DEKRA Testing and Certification.
4. This test report cannot be used partially or in full for publicity and/or promotional purposes without previous written permission of DEKRA Testing and Certification and the Accreditation Bodies.

Uncertainty

Uncertainty (factor $k=2$) was calculated according to the DEKRA Testing and Certification internal document PODT000.

Usage of samples

Samples undergoing test have been selected by: **the client**

Sample S/01 is composed of the following elements:

Control N°	Description	Model	Serial N°	Date of reception
53613B/011	Electronic lock	AF0J	---	2017-09-25

1. Sample S/01 has undergone following test(s).

All tests indicated in appendix A.

Test sample description

The test sample consists of a new AElement reader with HID iCLASS and Bluetooth Smart (BGM111) technology. Electronic and batteries inside the door.

Identification of the client

SALTO Systems, S.L.

Arkotz 9, Polígono Lanbarren

20180, Oiartzun, Gipuzkoa, SPAIN

Testing period

The performed test started on 2017-09-26 and finished on 2017-11-29.

The tests have been performed at DEKRA Testing and Certification.

Environmental conditions

In the control chamber, the following limits were not exceeded during the test:

Temperature	Min. = 15 °C Max. = 35 °C
Relative humidity	Min. = 20 % Max. = 75 %
Shielding effectiveness	> 100 dB

In the semianechoic chamber, the following limits were not exceeded during the test:

Temperature	Min. = 15 °C Max. = 35 °C
Relative humidity	Min. = 20 % Max. = 75 %
Air pressure	Min. = 860 mbar Max. = 1060 mbar
Shielding effectiveness	> 100 dB
Normal site attenuation (NSA)	< ±4 dB at 10 m distance between item under test and receiver antenna, (30 MHz to 1000 MHz)
Field homogeneity	More than 75% of illuminated surface is between 0 and 6 dB (26 MHz to 1000 MHz).

In the chamber for conducted measurements, the following limits were not exceeded during the test:

Temperature	Min. = 15 °C Max. = 35 °C
Relative humidity	Min. = 20 % Max. = 75 %
Air pressure	Min. = 860 mbar Max. = 1060 mbar
Shielding effectiveness	> 100 dB

Remarks and comments

- 1: Tests have been performed by the technical personnel: Carolina Postigo.
- 2: Used instrumentation.

Conducted Measurements

	Last Cal. date	Cal. due date
1. Spectrum analyser Rohde & Schwarz FSV40	2017/09	2019/07
2. Climatic chamber HERAEUS VM 04/35	2016/03	2018/03
3. DC power supply KEYSIGHT TECHNOLOGIES U8002A	N.A.	N.A.
4. Vector Signal analyser R&S FSQ8	2016/06	2018/06
5. Digital multimeter FLUKE 113	2017/05	2019/05

Radiated Measurements

	Last Cal. date	Cal. due date
1. Semianechoic Absorber Lined Chamber ETS FACT3 200STP	N.A.	N.A.
2. BiconicalLog antenna ETS LINDGREN 3142E	2015/09	2018/09
3. Multi Device Controller EMCO 2090	N.A.	N.A.
4. EMI Test Receiver R&S ESU 40	2016/03	2018/03
5. RF pre-amplifier 30 MHz-6 GHz Bonn Elektronik BLNA 0360-01N	2017/07	2018/07
6. Loop antenna HP 1196 A.	2016/05	2018/05
7. Antenna tripod EMCO 11968C.	N.A.	N.A.

Testing verdicts

Not applicable	N/A
Pass	P
Fail	F
Not measured	N/M

FCC PART 15/RSS-210 PARAGRAPH	VERDICT			
	NA	P	F	NM
15.225 Subclause (a) / RSS-210 Clause B.6 (a). Field strength of emissions within the band 13.553 MHz -13.567 MHz		P		
15.225 Subclause (b) / RSS-210 Clause B.6 (b). Field strength of emissions within the band 13.410 - 13.553 MHz and 13.567 – 13.710 MHz		P		
15.225 Subclause (c) / RSS-210 Clause B.6 (c). Field strength of emissions within the band 13.110 - 13.410 MHz and 13.710 – 14.010 MHz		P		
15.225 Subclause (d) / RSS-210 Clause B.6 (d). Field strength of emissions outside of the band 13.110 MHz -14.010 MHz		P		
15.225 Subclause (e) / RSS-210 Clause B.6. Frequency tolerance of the carrier signal		P		

Appendix A – Test result

INDEX

TEST CONDITIONS	9
Occupied Bandwidth	12
Section 15.225 Subclause (a) / RSS-210 Clause B.6 (a). Field strength of emissions within the band 13.553 MHz -13.567 MHz.....	13
Section 15.225 Subclause (b) / RSS-210 Clause B.6 (b). Field strength of emissions within the band 13.410 MHz -13.553 MHz and 13.567 MHz -13.710 MHz.....	14
Section 15.225 Subclause (c) / RSS-210 Clause B.6 (c). Field strength of emissions within the band 13.110 MHz -13.410 MHz and 13.710 MHz -14.010 MHz.....	16
Section 15.225 Subclause (d) / RSS-210 Clause B.6 (d). Field strength of emissions outside of the band 13.110 MHz - 14.010 MHz.....	18
Section 15.225 Subclause (e) / RSS-210 Clause B.6. Frequency tolerance of the carrier signal.....	21

TEST CONDITIONS

Power supply (V):

$$V_{\text{nominal}} = 4.5 \text{ Vdc}$$

$$V_{\text{min}} = 3.825 \text{ Vdc}$$

$$V_{\text{max}} = 5.175 \text{ Vdc}$$

The subscripts nom, min and max indicate voltage test conditions (nominal, minimum and maximum respectively, as declared by the applicant).

Type of power supply = DC voltage from batteries.

Type of antenna = Integral antenna

Operating Temperature Range (°C):

$$T_{\text{nom}} = +15 \text{ to } +35$$

TEST FREQUENCIES:

Nominal Operating frequency: 13.56 MHz

CONDUCTED MEASUREMENTS

The equipment under test was set up in a shielded room and it is directly connected to the spectrum analyzer through a coupling device.



For frequency stability test the EUT was placed inside a climatic chamber and connected to a frequency meter using a low loss cable. An external DC power supply was connected to the EUT for voltage variation test.

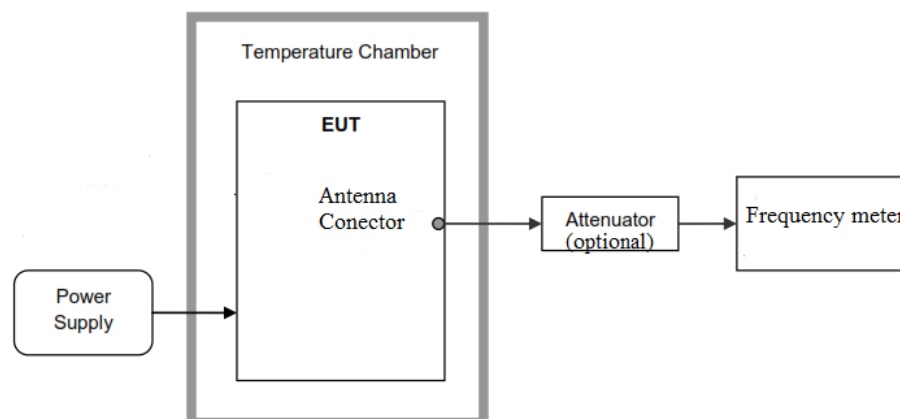

RADIATED MEASUREMENTS

All radiated tests were performed in a semi-anechoic chamber. The measurement antenna (Loop antenna for the range between 9 kHz to 30 MHz and Bilog antenna for the range between 30 MHz to 200 MHz) is situated at a distance of 3 m.

For radiated emissions in the range 9 kHz to 30 MHz that is performed at a distance closer than the specified distance, an inverse proportionality factor of 40 dB per decade is used to normalize the measured data for determining compliance.

The equipment under test was set up on a non-conductive platform above the ground plane and the situation and orientation was varied to find the maximum radiated emission. It was also rotated 360° and in the range between 30 MHz and 200 MHz the antenna height was varied from 1 to 4 meters to find the maximum radiated emission.

In the range between 9 kHz and 30 MHz the measurements were made in the three different orientation planes of the loop antenna to determine the maximum received field.

In the range between 30 MHz and 200 MHz the measurements were made in both horizontal and vertical planes of polarization.

The test was performed with the equipment transmitting first with only the 13.56 MHz radio and repeated with the 2.4 GHz BT LE radio transmitting simultaneously to check the impact of the co-location of the other radio interfaces. The results and plots below show the worst results obtained.

Radiated measurements setup 9 kHz to 30 MHz.

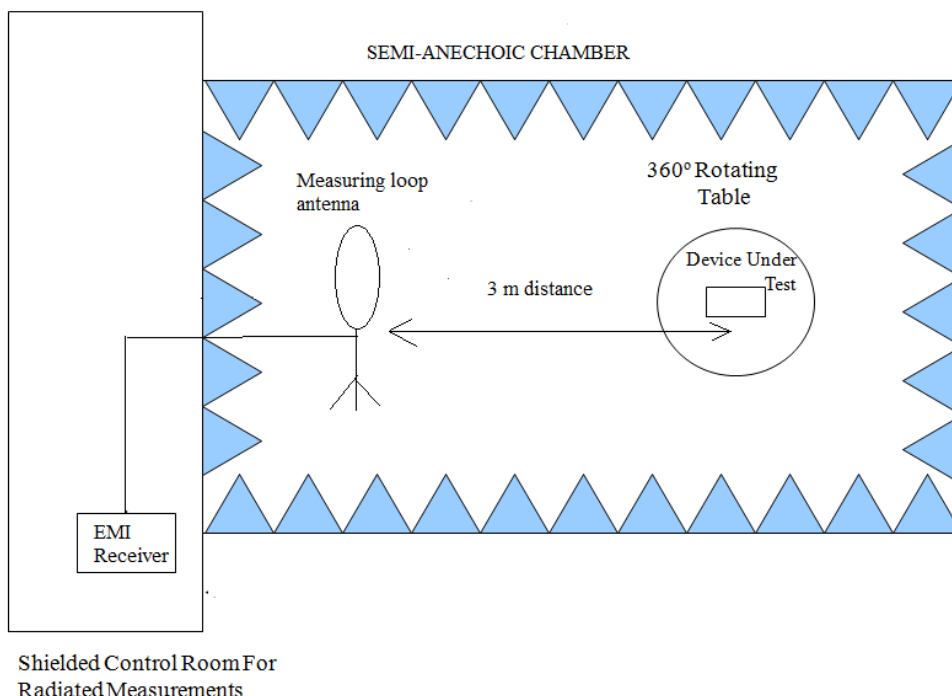

Radiated measurements setup 30 MHz to 200 MHz.

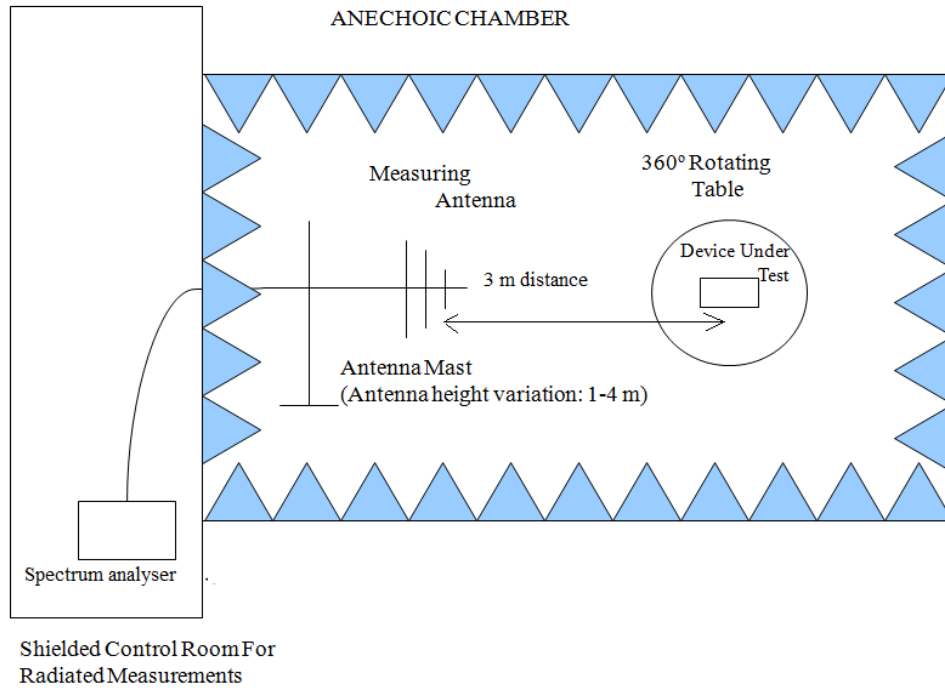

Occupied Bandwidth

RESULTS

99 % Occupied Bandwidth (see next plots).

Operation mode	99% occupied bandwidth (kHz)
NFC	834.6
Measurement uncertainty (kHz)	<±0.20

Operation mode: NFC

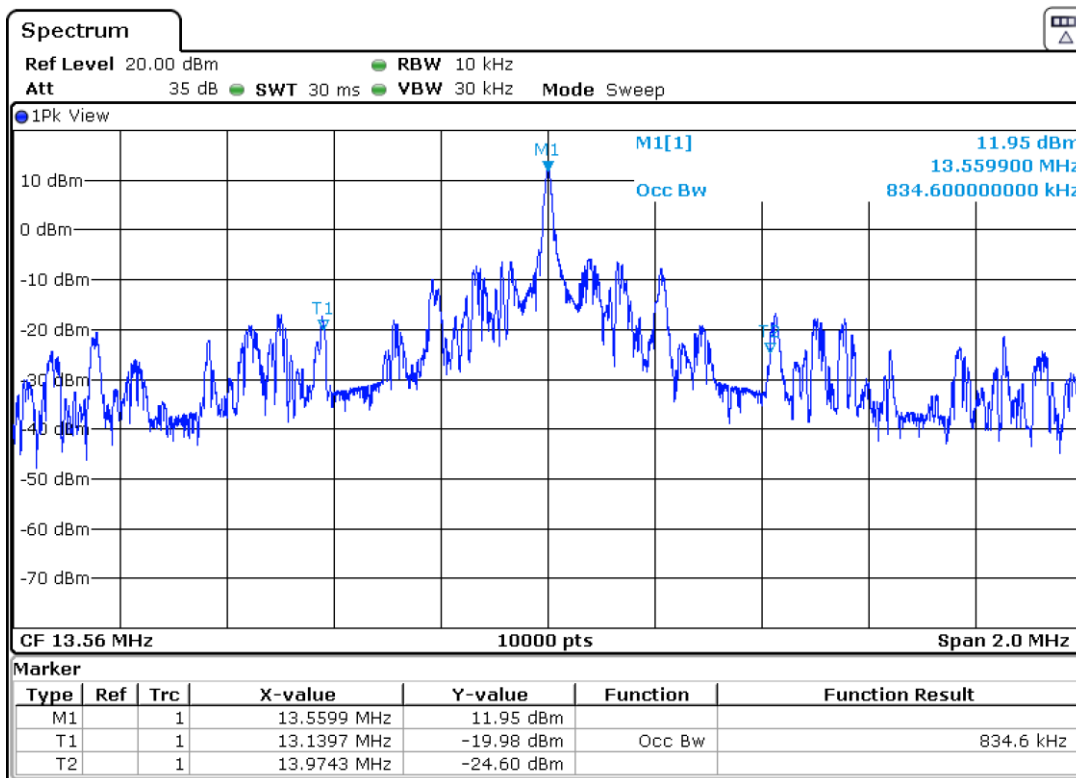

Section 15.225 Subclause (a) / RSS-210 Clause B.6 (a). Field strength of emissions within the band 13.553 MHz -13.567 MHz

SPECIFICATION

The field strength of any emissions within the band 13.553 – 13.567 MHz shall not exceed 15,848 microvolts/meter (84 dBμV/m) at 30 meters.

RESULTS

Measurement distance: 3 meters

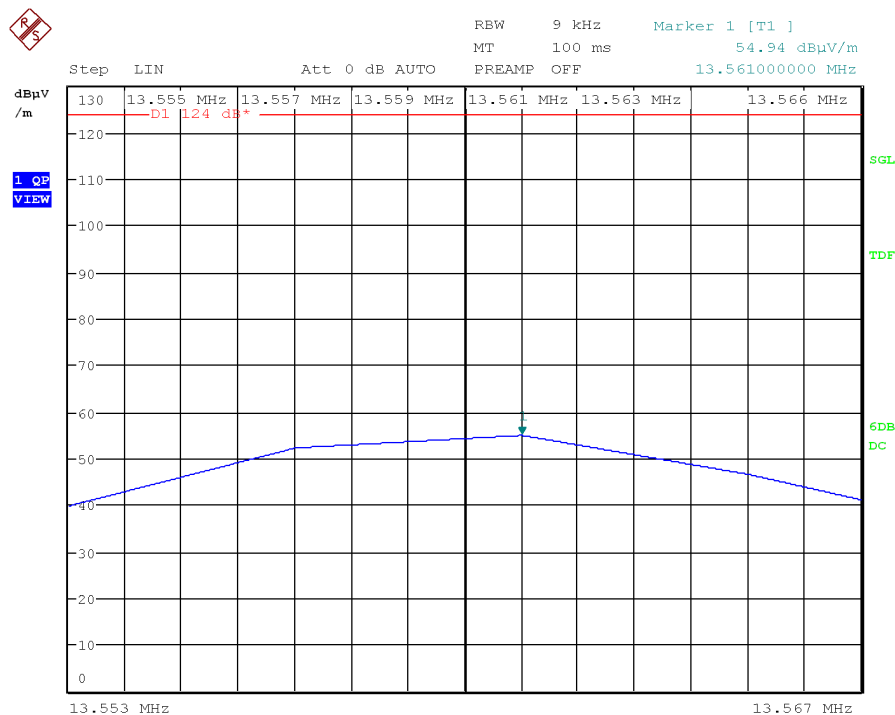

Note: The limit shown in the above plot is extrapolated to 3 meters

Frequency (MHz)	Maximum field strength (dBμV/m) measured at 3 m (quasi-peak detector)	Maximum field strength (dBμV/m) extrapolated to 30 m (40 dB/decade)
13.561	54.94	14.94
Measurement uncertainty (dB)	<±3.61	

Verdict: PASS

Section 15.225 Subclause (b) / RSS-210 Clause B.6 (b). Field strength of emissions within the band 13.410 MHz -13.553 MHz and 13.567 MHz -13.710 MHz

SPECIFICATION

Within the bands 13.410-13.553 MHz and 13.567-13.710 MHz, the field strength of any emissions shall not exceed 334 microvolts/meter (50.47 dBμV/m) at 30 meters.

RESULTS

Band 13.410-13.553 MHz

Measurement distance: 3 meters.

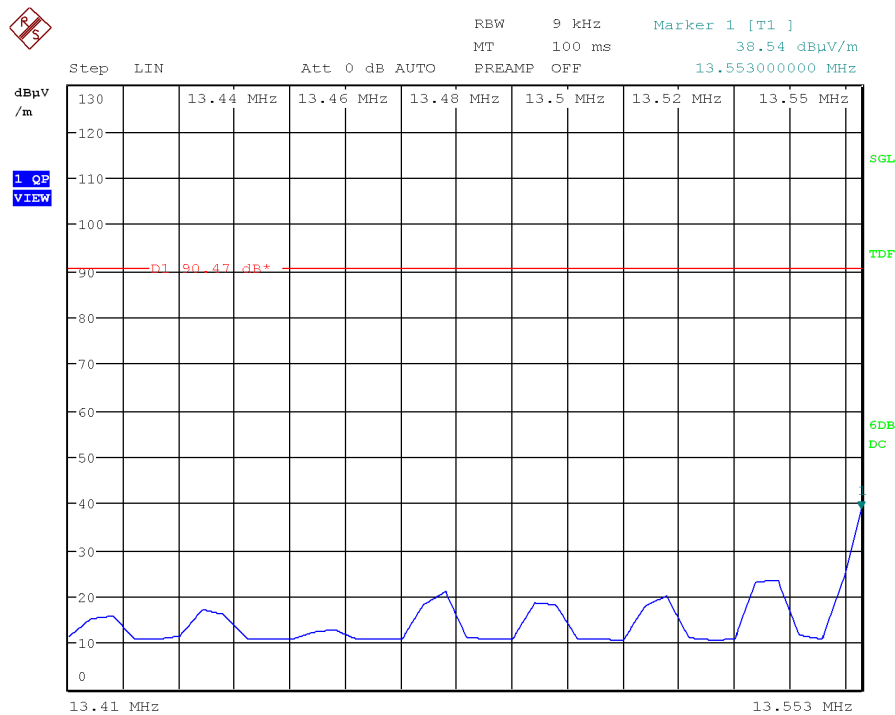

Note: The limit shown in the above plot is extrapolated to 3 meters

Frequency (MHz)	Maximum field strength (dBμV/m) measured at 3 m (quasi-peak detector)	Maximum field strength (dBμV/m) extrapolated to 30 m (40 dB/decade)
13.553	38.54	-1.46
Measurement uncertainty (dB)	<±3.61	

Verdict: PASS

Band 13.567-13.710 MHz

Measurement distance: 3 meters.

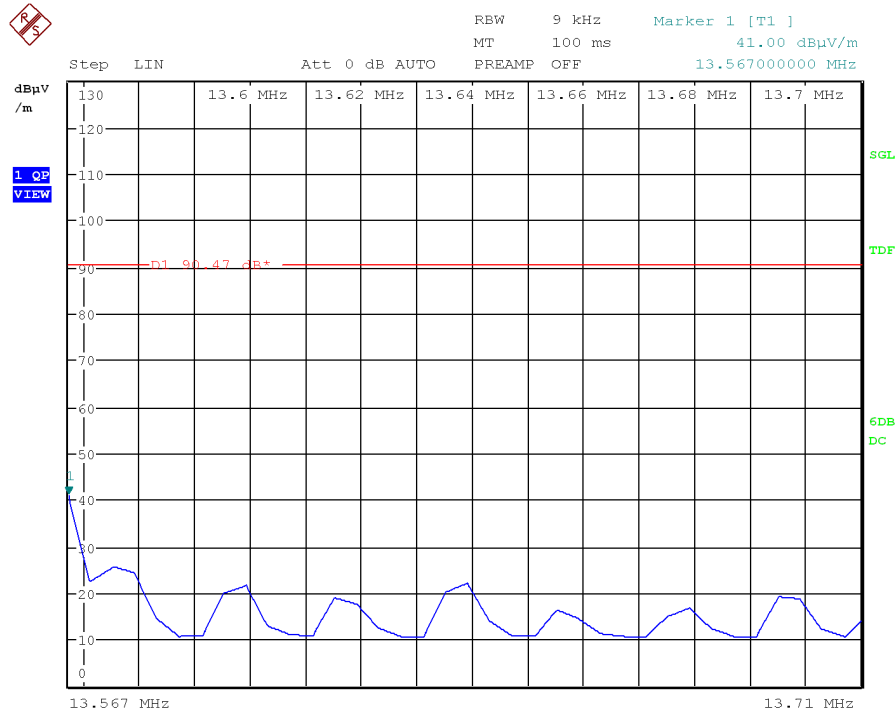

Note: The limit shown in the above plot is extrapolated to 3 meters

Frequency (MHz)	Maximum field strength (dBµV/m) measured at 3 m (quasi-peak detector)	Maximum field strength (dBµV/m) extrapolated to 30 m (40 dB/decade)
13.567	41.00	1.00
Measurement uncertainty (dB)	<±3.61	

Verdict: PASS

Section 15.225 Subclause (c) / RSS-210 Clause B.6 (c). Field strength of emissions within the band 13.110 MHz -13.410 MHz and 13.710 MHz -14.010 MHz

SPECIFICATION

Within the bands 13.110-13.410 MHz and 13.710-14.010 MHz, the field strength of any emissions shall not exceed 106 microvolts/meter (40.51 dBµV/m) at 30 meters.

RESULTS

Band 13.110-13.410 MHz

Measurement distance: 3 meters.

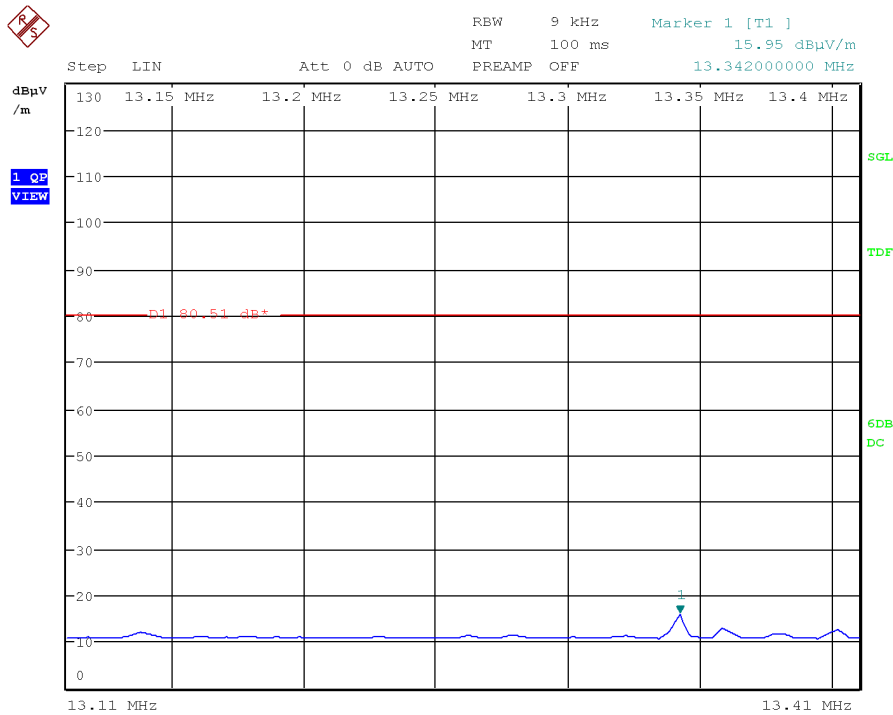

Note: The limit shown in the above plot is extrapolated to 3 meters

Frequency (MHz)	Maximum field strength (dBµV/m) measured at 3 m (quasi-peak detector)	Maximum field strength (dBµV/m) extrapolated to 30 m (40 dB/decade)
13.342	15.95	-24.05
Measurement uncertainty (dB)	<±3.61	

Verdict: PASS

Band 13.710-14.010 MHz

Measurement distance: 3 meters.

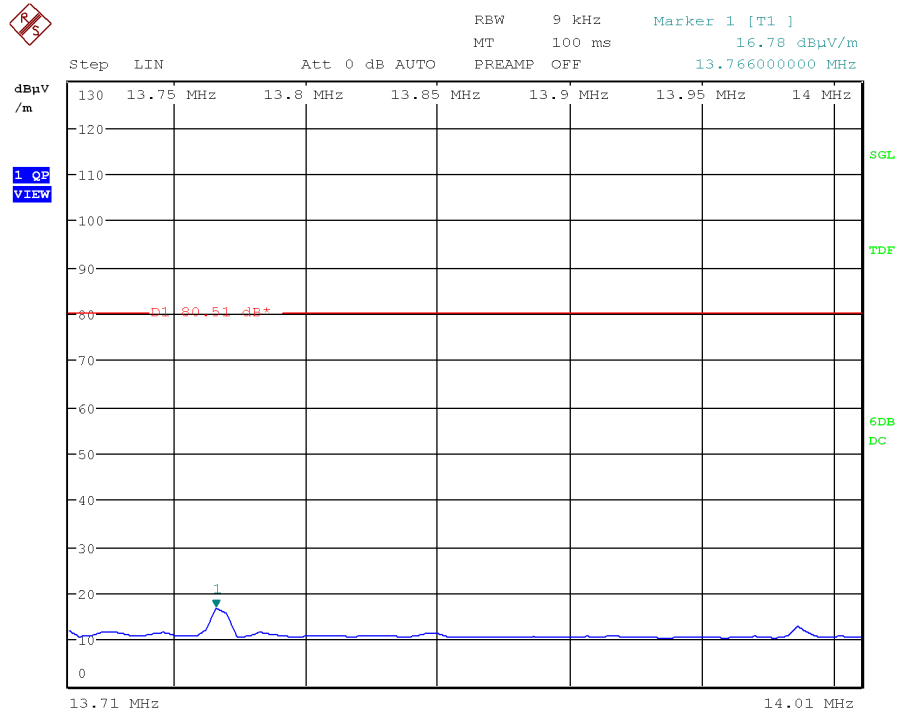

Note: The limit shown in the above plot is extrapolated to 3 meters

Frequency (MHz)	Maximum field strength (dBµV/m) measured at 3 m (quasi-peak detector)	Maximum field strength (dBµV/m) extrapolated to 30 m (40 dB/decade)
13.766	16.78	-23.22
Measurement uncertainty (dB)	±3.61	

Verdict: PASS

Section 15.225 Subclause (d) / RSS-210 Clause B.6 (d). Field strength of emissions outside of the band 13.110 MHz -14.010 MHz

SPECIFICATION

Field strength of any emissions appearing outside of the band 13.110 MHz - 14.010 MHz band shall not exceed the general radiated emission limits in 15.209/RSS-Gen:

Frequency Range (MHz)	Field strength ($\mu\text{V/m}$)	Field strength ($\text{dB}\mu\text{V/m}$)	Measurement distance (m)
0.009-0.490	2400/F(kHz)	-	300
0.490-1.705	24000/F(kHz)	-	30
1.705 - 30.0	30	29.54	30
30 - 88	100	40	3
88 - 216	150	43.5	3
216 - 960	200	46	3
Above 960	500	54	3

RESULTS:

All tests were performed in a semi-anechoic chamber at a distance of 3 m.

The spectrum was inspected from 9 kHz to 200 MHz searching for spurious signals.

The field strength is calculated by adding correction factor to the measured level from the spectrum analyzer. This correction factor includes antenna factor, cable loss and pre-amplifier gain.

Frequency range 9 kHz-30 MHz.

No spurious signals were found at less than 20 dB below the limit.

Frequency range 30 MHz-200 MHz

Spurious signals closest to the limit.

Spurious frequency (MHz)	Polarization	Detector	Emission Level ($\text{dB}\mu\text{V/m}$)	Measurement Uncertainty (dB)
40.676	V	Quasi-peak	30.75	± 3.88
54.242	V	Quasi-peak	29.60	± 3.88
67.808	V	Quasi-peak	35.45	± 3.88
149.187	V	Quasi-peak	23.92	± 3.88
176.285	V	Quasi-peak	30.97	± 3.88

Verdict: PASS

FREQUENCY RANGE 9 kHz-30 MHz.

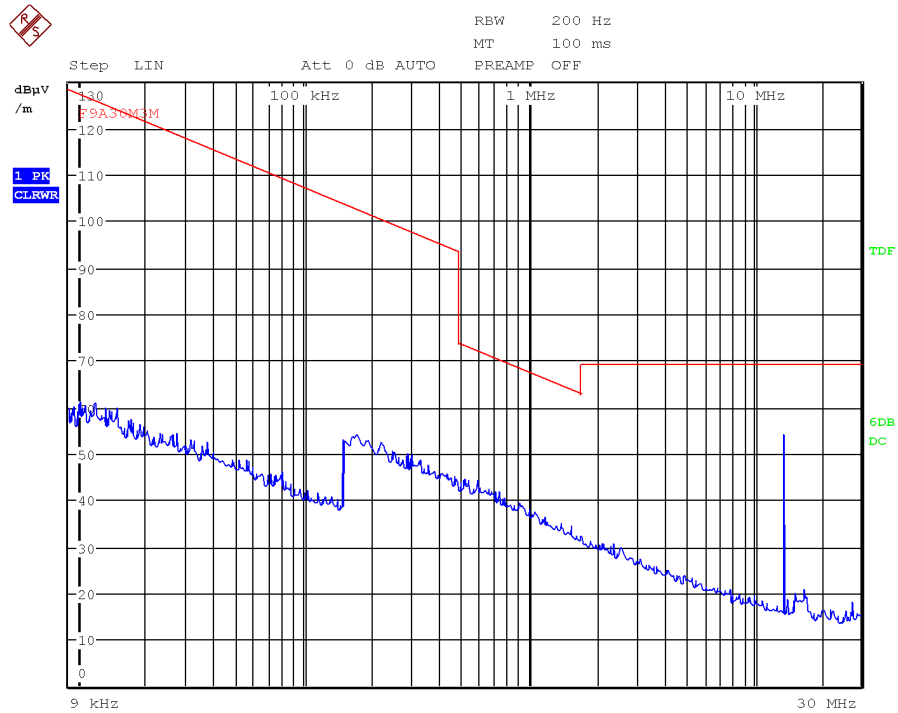

Note: The limits shown in the above plot are extrapolated to 3 meters. The highest peak corresponds to the carrier level.

Resolution bandwidth:
 200 Hz for $9 \text{ kHz} \leq f \leq 150 \text{ kHz}$
 9 kHz for $150 \text{ kHz} \leq f \leq 30 \text{ MHz}$

FREQUENCY RANGE 30 MHz to 200 MHz.

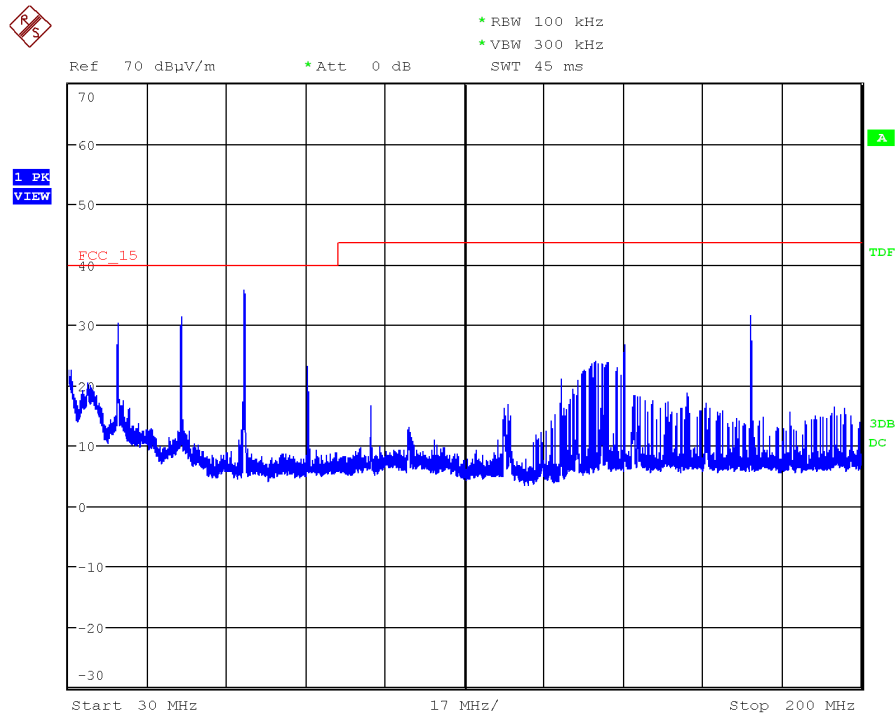

Note: The above plot shows the results of the scan using peak detector.

Section 15.225 Subclause (e) / RSS-210 Clause B.6. Frequency tolerance of the carrier signal

SPECIFICATION

The frequency tolerance of the carrier signal shall be maintained within +/- 0.01% of the operating frequency over a temperature variation of -20 degrees to +50 degrees C at normal supply voltage, and for a variation in the primary supply voltage from 85% to 115% of the rated supply voltage at a temperature of 20 degrees C. For hand carried, battery powered equipment, reduce primary supply voltage to the battery operating end point which shall be specified by the manufacturer.

RESULTS

Nominal operating frequency: 13.56 MHz

Frequency stability over temperature variations.

Temperature (°C)	Frequency Error (Hz)	Frequency Error (%)
+50	240	0.00177
+40	231	0.00170
+30	227	0.00167
+20	242	0.00178
+10	244	0.00180
0	246	0.00181
-10	246	0.00181
-20	222	0.00164

Frequency stability over voltage variations.

DC Supply voltage	Voltage (V)	Frequency Error (Hz)	Frequency Error (%)
Vmax	5.175	242	0.00178
Vmin	3.825	232	0.00171

Verdict: PASS