



**FCC 47 CFR PART 15 SUBPART C
INDUSTRY CANADA RSS-247 ISSUE 1**

CERTIFICATION TEST REPORT

FOR

BLE HYBRID WATCH

**MODEL NUMBER: NDW2A, NDW2B, NDW2C, NDW2D, NDW2M, NDW2W,
NDW2F, NDW2E, NDW2H, NDW2K, NDW2G, NDW2J**

**FCC ID: UK7-NDW2A
IC: 6708A-NDW2A**

REPORT NUMBER: 16U23613-E1V1

ISSUE DATE: JULY 8, 2016

Prepared for
**Fossil Group, Inc.
901 S. Central Expressway
Richardson, TX 75080 U.S.A.**

Prepared by
**UL VERIFICATION SERVICES INC.
47173 BENICIA STREET
FREMONT, CA 94538, U.S.A.
TEL: (510) 771-1000
FAX: (510) 661-0888**



NVLAP LAB CODE 200065-0

Revision History

Rev.	Issue Date	Revisions	Revised By
V1	7/8/16	Initial Issue	C. Vergonio

TABLE OF CONTENTS

1. ATTESTATION OF TEST RESULTS	4
2. TEST METHODOLOGY	5
3. FACILITIES AND ACCREDITATION	5
4. CALIBRATION AND UNCERTAINTY	5
4.1. <i>MEASURING INSTRUMENT CALIBRATION</i>	5
4.2. <i>SAMPLE CALCULATION</i>	5
4.3. <i>MEASUREMENT UNCERTAINTY</i>	6
5. EQUIPMENT UNDER TEST	7
5.1. <i>DESCRIPTION OF EUT</i>	7
5.2. <i>MODEL DIFFERENCES</i>	7
5.3. <i>MAXIMUM OUTPUT E-FIELD STRENGTH</i>	8
5.4. <i>DESCRIPTION OF AVAILABLE ANTENNAS</i>	8
5.5. <i>SOFTWARE AND FIRMWARE</i>	8
5.6. <i>WORST-CASE CONFIGURATION AND MODE</i>	8
5.7. <i>DESCRIPTION OF TEST SETUP</i>	9
6. TEST AND MEASUREMENT EQUIPMENT	11
7. TEST RESULTS	12
7.1. <i>ANTENNA PORT TEST RESULTS</i>	12
7.1.1. <i>ON TIME AND DUTY CYCLE</i>	12
7.1.2. <i>99% BANDWIDTH</i>	13
7.2. <i>RADIATED EMISSIONS</i>	16
7.2.1. <i>FUNDAMENTAL FREQUENCY RADIATED EMISSION</i>	17
7.2.2. <i>TRANSMITTER RESTRICTED BAND EDGES</i>	18
7.2.3. <i>HARMONICS AND SPURIOUS EMISSIONS ABOVE 1GHz</i>	22
7.2.1. <i>WORST-CASE BELOW 30 MHz</i>	28
7.2.2. <i>WORST-CASE BELOW 1 GHz</i>	29
7.2.3. <i>WORST-CASE ABOVE 18 GHz</i>	31
8. SETUP PHOTOS	33

1. ATTESTATION OF TEST RESULTS

COMPANY NAME: Fossil Group, Inc.
901 S. Central Expressway,
Richardson, TX 75080 U.S.A.

EUT DESCRIPTION: BLE HYBRID WATCH

MODEL: NDW2A, NDW2B, NDW2C, NDW2D, NDW2M, NDW2W, NDW2F,
NDW2E, NDW2H, NDW2K, NDW2G, NDW2J

SERIAL NUMBER: SAM13EB145 (Radiated); SAM19EB060 (Conducted)

DATE TESTED: June 30 to July 07, 2016

APPLICABLE STANDARDS	
STANDARD	TEST RESULTS
CFR 47 Part 15 Subpart C	Pass
INDUSTRY CANADA RSS-247 Issue 1	Pass
INDUSTRY CANADA RSS-GEN Issue 4	Pass

UL Verification Services Inc. tested the above equipment in accordance with the requirements set forth in the above standards. All indications of Pass/Fail in this report are opinions expressed by UL Verification Services Inc. based on interpretations and/or observations of test results. Measurement Uncertainties were not taken into account and are published for informational purposes only. The test results show that the equipment tested is capable of demonstrating compliance with the requirements as documented in this report.

Note: The results documented in this report apply only to the tested sample, under the conditions and modes of operation as described herein. This document may not be altered or revised in any way unless done so by UL Verification Services Inc. and all revisions are duly noted in the revisions section. Any alteration of this document not carried out by UL Verification Services Inc. will constitute fraud and shall nullify the document. This report must not be used by the client to claim product certification, approval, or endorsement by NVLAP, NIST, any agency of the Federal Government, or any agency of any government.

Approved & Released For
UL Verification Services Inc. By:



CHARLES VERGONIO
WiSE ENGINEER
UL Verification Services Inc.

Prepared By:



JASON QIAN
WiSE LAB ENGINEER
UL Verification Services Inc.

2. TEST METHODOLOGY

The tests documented in this report were performed in accordance with ANSI C63.10-2013, FCC CFR 47 Part 2, FCC CFR 47 Part 15, RSS-GEN Issue 4, and RSS-247 Issue 1.

3. FACILITIES AND ACCREDITATION

The test sites and measurement facilities used to collect data are located at 47173 Benicia Street, Fremont, California, USA.

The test sites and measurement facilities used to collect data are located at 47173 and 47266 Benicia Street, Fremont, California, USA. Line conducted emissions are measured only at the 47173 address. The following table identifies which facilities were utilized for radiated emission measurements documented in this report. Specific facilities are also identified in the test results sections.

47173 Benicia Street	47266 Benicia Street
<input type="checkbox"/> Chamber A	<input type="checkbox"/> Chamber D
<input checked="" type="checkbox"/> Chamber B	<input type="checkbox"/> Chamber E
<input checked="" type="checkbox"/> Chamber C	<input type="checkbox"/> Chamber F
	<input type="checkbox"/> Chamber G
	<input type="checkbox"/> Chamber H

The above test sites and facilities are covered under FCC Test Firm Registration # 208313. Chambers A through H are covered under Industry Canada company address code 2324B with site numbers 2324B -1 through 2324B-8, respectively.

UL Verification Services Inc. is accredited by NVLAP, Laboratory Code 200065-0. The full scope of accreditation can be viewed at <http://ts.nist.gov/standards/scopes/2000650.htm>.

4. CALIBRATION AND UNCERTAINTY

4.1. MEASURING INSTRUMENT CALIBRATION

The measuring equipment utilized to perform the tests documented in this report has been calibrated in accordance with the manufacturer's recommendations, and is traceable to recognized national standards.

4.2. SAMPLE CALCULATION

Where relevant, the following sample calculation is provided:

$$\begin{aligned} \text{Field Strength (dBuV/m)} &= \text{Measured Voltage (dBuV)} + \text{Antenna Factor (dB/m)} + \\ &\text{Cable Loss (dB)} - \text{Preamp Gain (dB)} \\ 36.5 \text{ dBuV} + 18.7 \text{ dB/m} + 0.6 \text{ dB} - 26.9 \text{ dB} &= 28.9 \text{ dBuV/m} \end{aligned}$$

4.3. MEASUREMENT UNCERTAINTY

Where relevant, the following measurement uncertainty levels have been estimated for tests performed on the apparatus:

PARAMETER	UNCERTAINTY
Conducted Disturbance, 9KHz to 0.15 MHz	3.84 dB
Conducted Disturbance, 0.15 to 30 MHz	3.65 dB
Radiated Disturbance, 9KHz to 30 MHz	3.15 dB
Radiated Disturbance, 30 to 1000 MHz	5.36 dB
Radiated Disturbance, 1000 to 18000 MHz	4.32 dB
Radiated Disturbance, 18000 to 26000 MHz	4.45 dB
Radiated Disturbance, 26000 to 40000 MHz	5.24 dB

Uncertainty figures are valid to a confidence level of 95%.

5. EQUIPMENT UNDER TEST

5.1. DESCRIPTION OF EUT

The EUT is a BLE Hybrid Watch.

5.2. MODEL DIFFERENCES

According to Manufacturer Attestation Letter, unlicensed radio is electrically identical and the PCBA are identical in all models. They share the same chipset, same power and same antenna performance including antenna gain. Please refer to table below for Model differences.

Platform #	NDW2A	NDW2B	NDW2C	NDW2D	NDW2M	NDW2W	NDW2F	NDW2E	NDW2H	NDW2K	NDW2G	NDW2J
Case Materials	Stainless Steel	Stainless Steel	Stainless Steel	Stainless Steel	Stainless Steel	Stainless Steel	Stainless Steel	Stainless Steel	Stainless Steel	Stainless Steel	Stainless Steel	Stainless Steel
Strap Materials	Stainless Steel, Leather, Silicon	Stainless Steel, Leather, Silicon	Stainless Steel, Leather, Silicon	Stainless Steel, Leather, Silicon	Stainless Steel, Leather, Grosgrain, Silicon	Stainless Steel, Leather, Grosgrain, Silicon	Stainless Steel	Stainless Steel, Leather	Stainless Steel, Leather	Stainless Steel, Leather	Stainless Steel, Leather	Leather, Silicon
Case Sizes	40mm, 46mm, 50mm options	40mm, 46mm, 50mm options	40mm, 46mm, 50mm options	40mm, 46mm, 50mm options	38mm, 44mm	38mm, 44mm	42mm	45mm	43mm	39.5mm	42mm	46mm
Auto Time	✓	✓	✓	✓	✓	✓	✓	✓	✓	✓	✓	✓
2nd Time Zone	✓	✓	✓	✓	✓	✓	✓	✓	✓		✓	✓
Smart Alarm	✓	✓	✓	✓	✓	✓	✓	✓	✓	✓	✓	✓
Date	✓	✓	✓	✓	✓	✓	✓	✓	✓		✓	✓
LINK	✓	✓	✓	✓	✓	✓	✓	✓	✓	✓	✓	✓
Countdown										✓		
Customization	Interchangeable Straps	Interchangeable Straps	Interchangeable Straps	Interchangeable Straps	Interchangeable Straps	Interchangeable Straps	Interchangeable Straps	Interchangeable Straps	Interchangeable Straps		Interchangeable Straps	Interchangeable Straps

5.3. MAXIMUM OUTPUT E-FIELD STRENGTH

The transmitter has a maximum output peak E-field as follows:

Frequency Range (MHz)	Mode	Output PK E-field Strength (dBuV/m)
2480	BLE	84.69

5.4. DESCRIPTION OF AVAILABLE ANTENNAS

The radio utilizes a Loop Trace antenna, with a maximum gain of -11.58 dBi.

5.5. SOFTWARE AND FIRMWARE

The test utility software used during testing was Connection Manager by Dialog Semiconductor, rev. 3.0.10.

5.6. WORST-CASE CONFIGURATION AND MODE

Radiated emission was performed with the EUT set to transmit at the channel with highest output power as worst-case scenario.

Worst-Case was investigated on Radiated Fundamental and Bandedge testing for all models and styles. Model NDW2J (DZT1000) was determined to be worst-case and performed emission testing.

The fundamental of the EUT was investigated in three orthogonal orientations X, Y, Z, it was determined that Y orientation was worst-case orientation; therefore, all final radiated testing was performed with the EUT in Y orientation.

5.7. DESCRIPTION OF TEST SETUP

SUPPORT EQUIPMENT

Support Equipment List			
Description	Manufacturer	Model	Serial Number
Laptop	Lenovo	2349CW5	PBB4M4Y
AC Adapter	Lenovo	ADLX90NLT2A	N/A
DC Power Supply	Sorensen	XT 20-3	1318A00530

I/O CABLES

I/O Cable List						
Cable No	Port	# of identical ports	Connector Type	Cable Type	Cable Length (m)	Remarks
1	USB	1	USB-Serial	Shielded	1.8	EUT to Laptop
2	DC	1	Banana Plug	Shielded	0.5m	EUT to DC Power Supply
3	AC	1	3-prong	Shielded	1.5m	Laptop to AC Mains
4	AC	1	3-prong	Shielded	1.5m	Power Supply to AC Mains

TEST SETUP

The EUT is connected with a host laptop computer by USB to Serial cable during the tests, test software exercised the radio.

SETUP DIAGRAM FOR TESTS

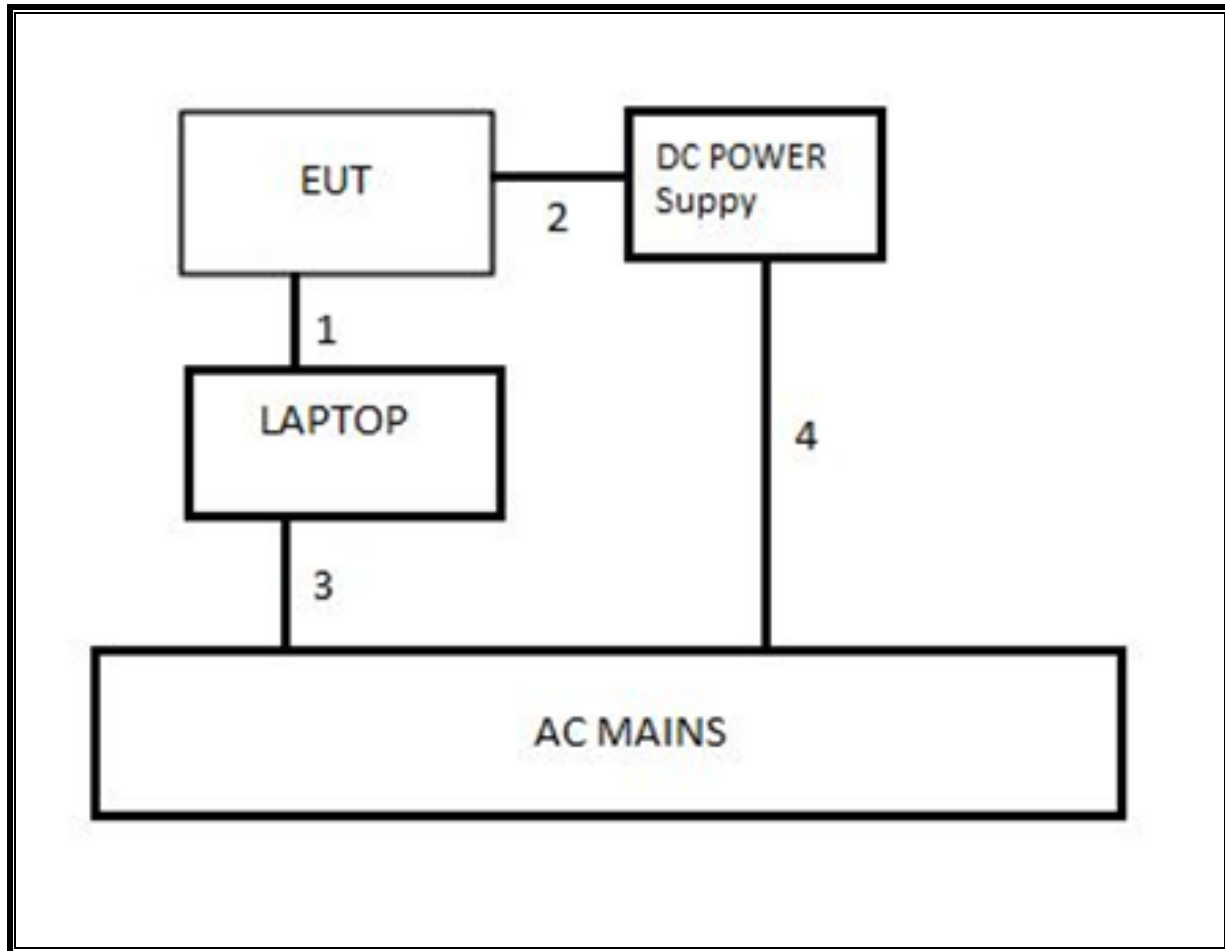

6. TEST AND MEASUREMENT EQUIPMENT

The following test and measurement equipment was utilized for the tests documented in this report:

Test Equipment List				
Description	Manufacturer	Model	T Number	Cal Due
Spectrum Analyzer, 44 GHz	Agilent / HP	E4446A	123	10/22/16
Spectrum Analyzer, PXA 3Hz to 44GHz	Keysight	N9030A	907	01/06/17
Spectrum Analyzer, PXA, 3Hz to 44GHz	Keysight	N9030A	1450	12/12/16
Antenna, Biconolog, 30MHz-1 GHz	Sunol Sciences	JB1	122	01/29/17
Antenna, Horn, 18GHz	ETS Lindgren	3117	119	02/04/17
Antenna, Horn, 18GHz	ETS Lindgren	3117	345	03/07/17
Antenna, Horn, 26.5 GHz	ARA	MWH-1826/B	447	06/16/17
Antenna, Loop, 9KHz to 30MHz	EMCO	80465	35	03/24/17
High Pass Filter 3GHz	Microtronics	HPM17543	485	03/09/17
RF Preamp, 1GHz - 18GHz	Miteq	NSP4000-SP2	493	04/07/17
RF Preamp, 18GHz - 26.5GHz	HP	8449B	404	11/29/16
RF Preamp, 1GHz - 8GHz	Miteq	AMF-4D-01000800-30-29p	1156	03/09/17
RF Preamp, 30MHz - 1GHz	HP	8447D	15	08/14/16

Test Software List			
Description	Manufacturer	Model	Version
Radiated Software	UL	UL EMC	Ver 9.5, Apr 26, 2016
Conducted Software	UL	UL EMC	Ver 9.5, May 26, 2015
Conducted Port Software	UL	UL RF	Ver 5.0, UNE 22, 2016

7.1.2. 99% BANDWIDTH

LIMITS

None; for reporting purposes only.

RESULTS

Frequency (MHz)	99% Bandwidth (MHz)
2402	1.0596
2442	1.0569
2480	1.0566

99% BANDWIDTH

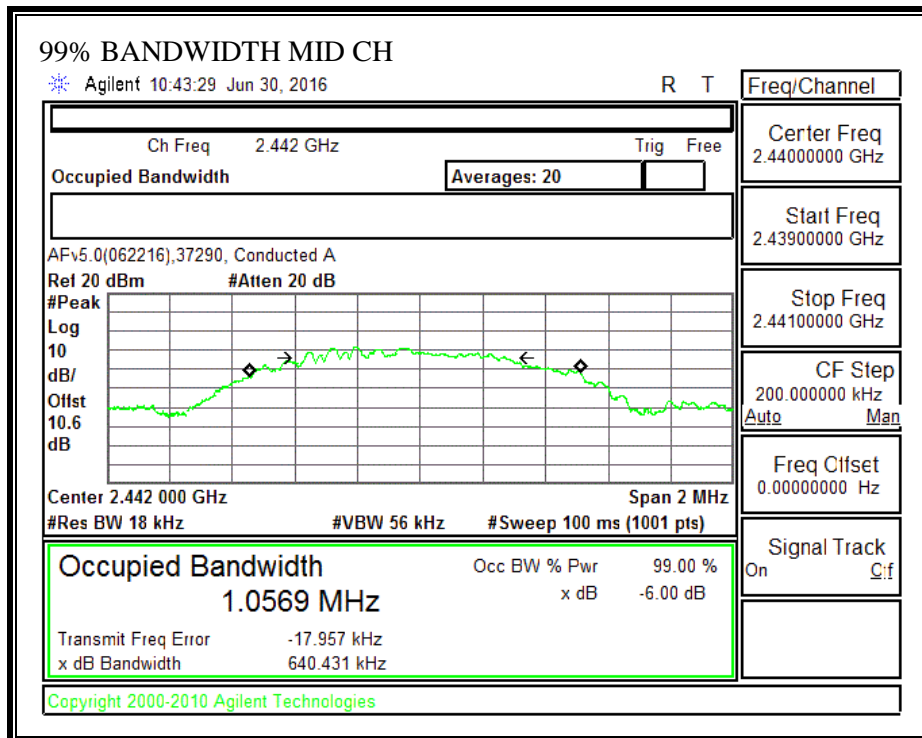
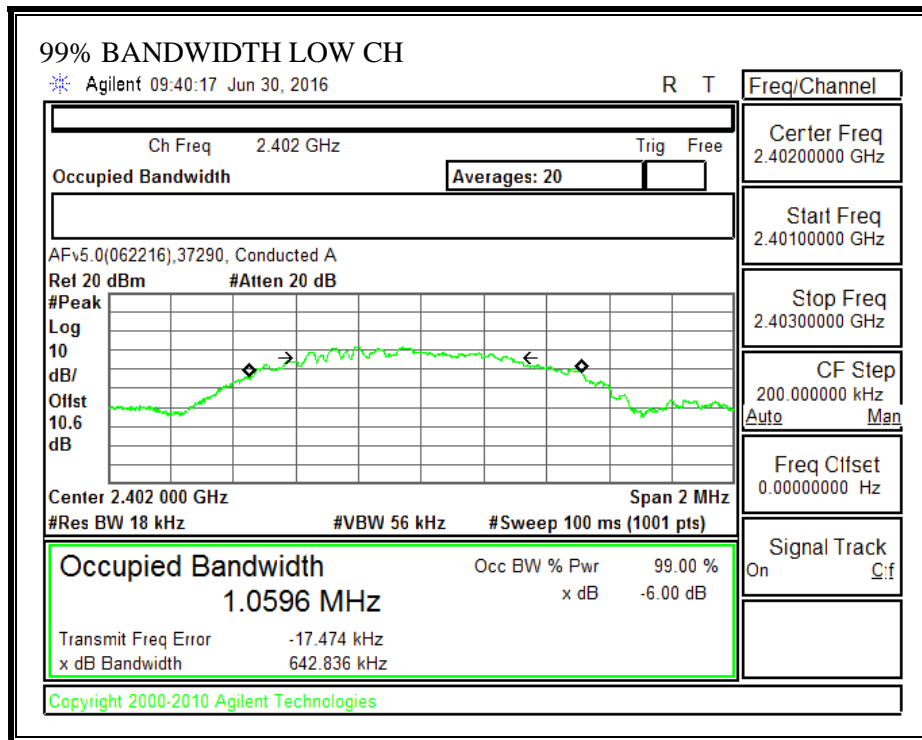

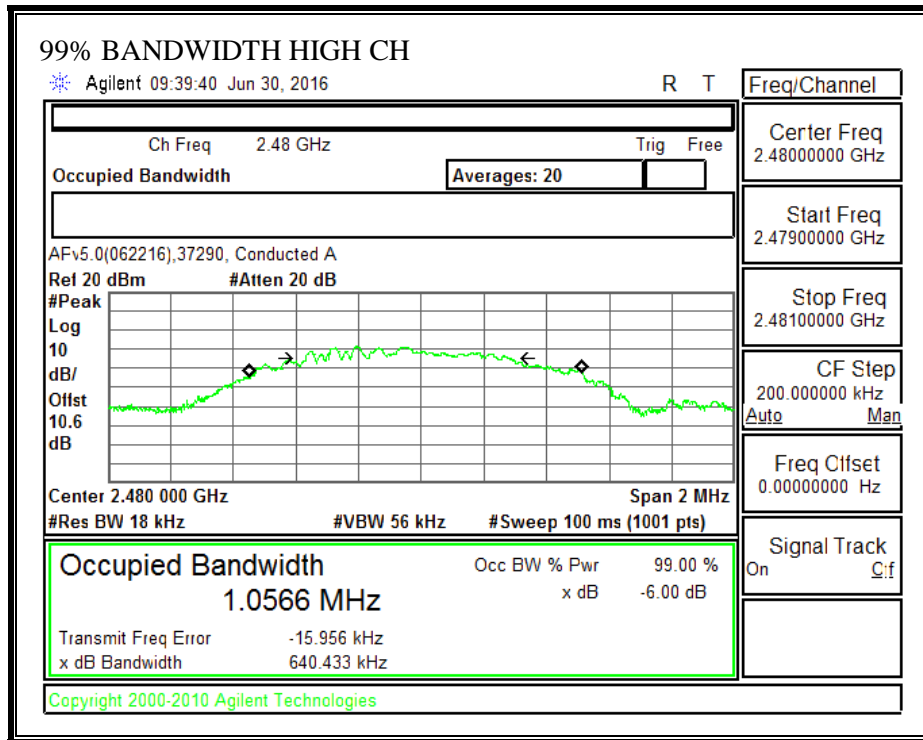

7.2. RADIATED EMISSIONS

LIMIT

IC RSS-210, A2.9
 FCC 15.249

Operation within the bands 902–928 MHz, 2400–2483.5 MHz, 5725–5875 MHz, and 24.0–24.25 GHz.

(a) Except as provided in paragraph (b) of this section, the field strength of emissions from intentional radiators operated within these frequency bands shall comply with the following:

Fundamental frequency	Field strength of fundamental (millivolts/meter)	Field strength of harmonics (microvolts/meter)
902–928 MHz	50	500
2400–2483.5 MHz	50	500
5725–5875 MHz	50	500
24.0–24.25 GHz	250	2500

(d) Emissions radiated outside of the specified frequency bands, except for harmonics, shall be attenuated by at least 50 dB below the level of the fundamental or to the general radiated emission limits in § 15.209, whichever is the lesser attenuation.

Frequency (MHz)	Field strength (microvolts/meter)	Measurement distance (meters)
0.009–0.490	2400/F(kHz)	300
0.490–1.705	24000/F(kHz)	30
1.705–30.0	30	30
30–88	100 **	3
88–216	150 **	3
216–960	200 **	3
Above 960	500	3

** Except as provided in paragraph (g), fundamental emissions from intentional radiators operating under this section shall not be located in the frequency bands 54–72 MHz, 76–88 MHz, 174–216 MHz or 470–806 MHz. However, operation within these frequency bands is permitted under other sections of this part, e.g., §§15.231 and 15.241.

RESULTS

7.2.1. FUNDAMENTAL FREQUENCY RADIATED EMISSION

Frequency (GHz)	Meter Reading (dBuV)	Det	AF T345 (dB/m)	Amp/Cbl/FI tr/Pad (dB)	DC Corr (dB)	Corrected Reading (dBuV/m)	Avg Limit (dBuV/m)	Margin (dB)	Peak Limit (dBuV/m)	PK Margin (dB)	Azimuth (Degs)	Height (cm)	Polarity
2.402	68.5	PK2	32.2	-22.4	0	78.3	-	-	114	-35.7	57	124	H
2.402	65.89	MAv1	32.2	-22.4	2.1	77.79	94	-16.21	-	-	57	124	H
2.402	73	PK2	32.2	-22.4	0	82.8	-	-	114	-31.2	218	126	V
2.402	70.03	MAv1	32.2	-22.4	2.1	81.93	94	-12.07	-	-	218	126	V
2.442	65.2	PK2	32.2	-22.3	0	75.1	-	-	114	-38.9	261	217	H
2.442	62.16	MAv1	32.2	-22.3	2.1	74.16	94	-19.84	-	-	261	217	H
2.442	72.26	PK2	32.2	-22.3	0	82.16	-	-	114	-31.84	232	150	V
2.442	69.39	MAv1	32.2	-22.3	2.1	81.39	94	-12.61	-	-	232	150	V
2.48	63.72	PK2	32.3	-22.2	0	73.82	-	-	114	-40.18	81	123	H
2.48	60.43	MAv1	32.3	-22.3	2.1	72.53	94	-21.47	-	-	81	123	H
2.48	74.69	PK2	32.3	-22.3	0	84.69	-	-	114	-29.31	224	212	V
2.48	71.85	MAv1	32.3	-22.3	2.1	83.95	94	-10.05	-	-	224	212	V

PK2 - KDB558074 Method: Maximum Peak
 MAv1 - KDB558074 Option 1: Maximum RMS Average

7.2.2. TRANSMITTER RESTRICTED BAND EDGES

RESTRICTED BANDEDGE (LOW CHANNEL, HORIZONTAL)

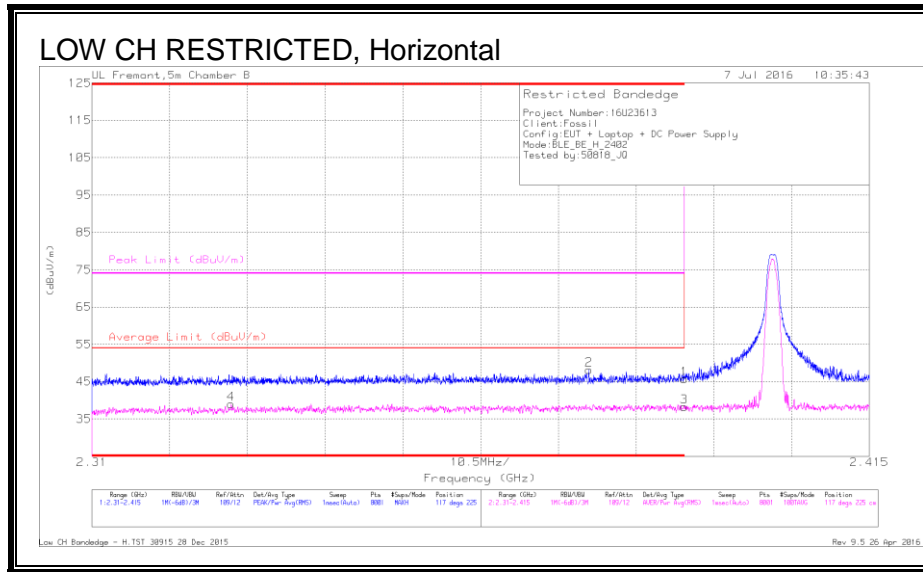

Trace Markers

Marker	Frequency (GHz)	Meter Reading (dBuV)	Det	AF T345 (dB/m)	Amp/Chl/Fitr/Pad (dB)	DC Corr (dB)	Corrected Reading (dBuV/m)	Average Limit (dBuV/m)	Margin (dB)	Peak Limit (dBuV/m)	PK Margin (dB)	Azimuth (Degs)	Height (cm)	Polarity
1	* 2.39	35.91	Pk	32.1	-22.3	0	45.71	-	-	74	-28.29	117	225	H
2	* 2.377	38.57	Pk	32	-22.4	0	48.17	-	-	74	-25.83	117	225	H
3	* 2.39	26.34	RMS	32.1	-22.3	2.1	38.24	54	-15.76	-	-	117	225	H
4	* 2.329	27.63	RMS	31.7	-22.4	2.1	39.03	54	-14.97	-	-	117	225	H

* - indicates frequency in CFR47 Pt 15 / IC RSS-Restricted Band

Pk - Peak detector

RMS - RMS detection

RESTRICTED BANDEDGE (LOW CHANNEL, VERTICAL)

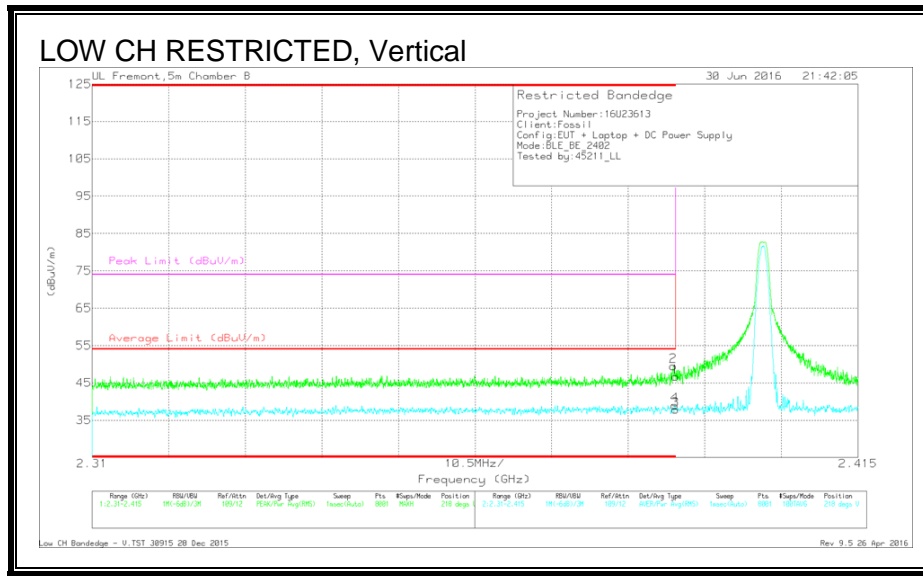

Trace Markers

Marker	Frequency (GHz)	Meter Reading (dBuV)	Det	AF T345 (dBm)	Amp/Ch/Filt/Pad (dB)	DC Corr (dB)	Corrected Reading (dBuV/m)	Average Limit (dBuV/m)	Margin (dB)	Peak Limit (dBuV/m)	PK Margin (dB)	Azimuth (Degs)	Height (cm)	Polarity
1	* 2.39	36.87	Pk	32.1	-22.3	0	46.67	-	-	74	-27.33	218	126	V
2	* 2.39	39.72	Pk	32.1	-22.3	0	49.52	-	-	74	-24.48	218	126	V
3	* 2.39	25.95	RMS	32.1	-22.3	2.1	37.85	54	-16.15	-	-	218	126	V
4	* 2.39	27.12	RMS	32.1	-22.3	2.1	39.02	54	-14.98	-	-	218	126	V

* - indicates frequency in CFR47 Pt 15 / IC RSS-Restricted Band

Pk - Peak detector

RMS - RMS detection

RESTRICTED BANDEDGE (HIGH CHANNEL, HORIZONTAL)

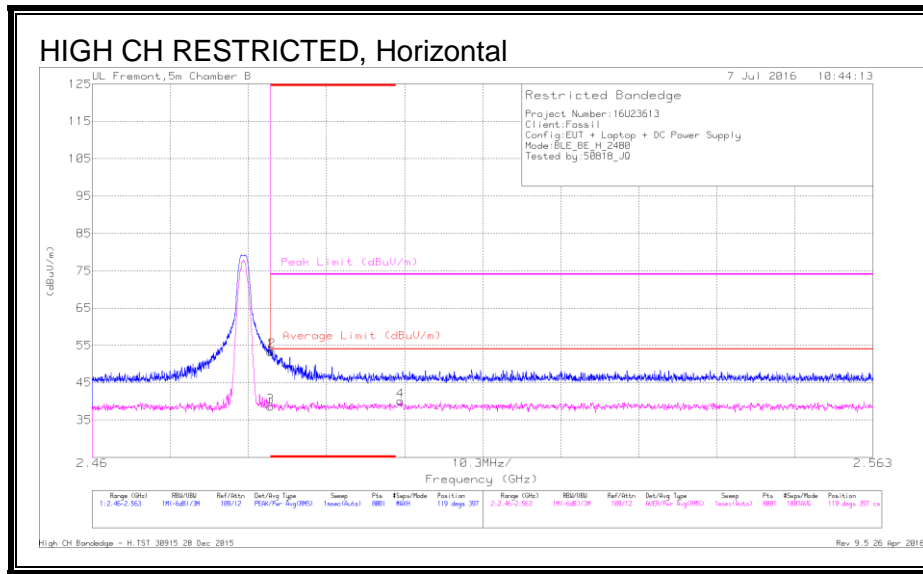

Trace Markers

Marker	Frequency (GHz)	Meter Reading (dBuV)	Det	AF T345 (dB/m)	Amp/CM/Filt/Pad (dB)	DC Corr (dB)	Corrected Reading (dBuV/m)	Average Limit (dBuV/m)	Margin (dB)	Peak Limit (dBuV/m)	PK Margin (dB)	Azimuth (Degs)	Height (cm)	Polarity
1	* 2.484	43.23	Pk	32.3	-22.3	0	53.23	-	-	74	-20.77	119	397	H
2	* 2.484	43.54	Pk	32.3	-22.3	0	53.54	-	-	74	-20.46	119	397	H
3	* 2.484	26.54	RMS	32.3	-22.3	2.1	38.64	54	-15.36	-	-	119	397	H
4	2.501	27.87	RMS	32.3	-22.2	2.1	40.07	54	-13.93	-	-	119	397	H

* - indicates frequency in CFR47 Pt 15 / IC RSS-Restricted Band

Pk - Peak detector

RMS - RMS detection

RESTRICTED BANDEDGE (HIGH CHANNEL, VERTICAL)

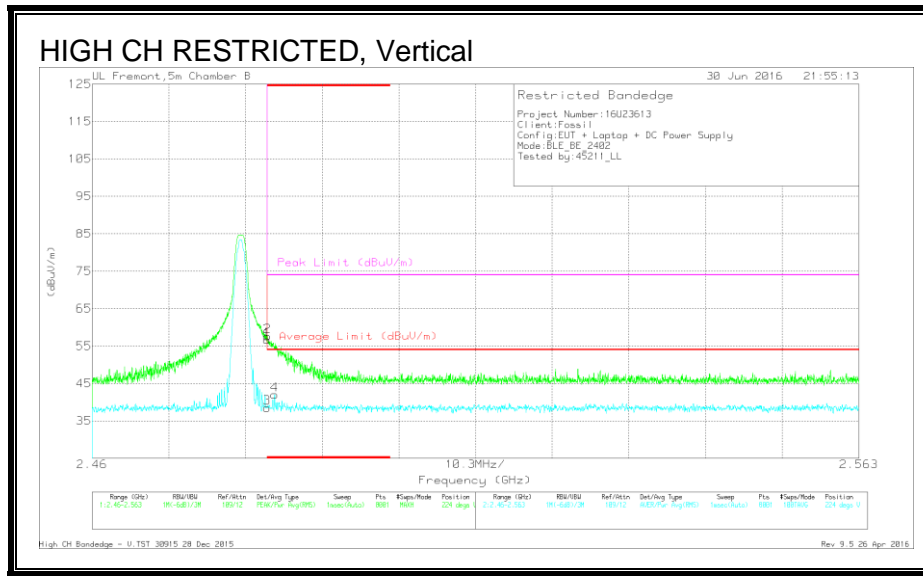

Trace Markers

Marker	Frequency (GHz)	Meter Reading (dBuV)	Det	AF T345 (dB/m)	Amp/Chl/Filt/Pad (dB)	DC Corr (dB)	Corrected Reading (dBuV/m)	Average Limit (dBuV/m)	Margin (dB)	Peak Limit (dBuV/m)	PK Margin (dB)	Azimuth (Degs)	Height (cm)	Polarity
1	* 2.484	46.68	Pk	32.3	-22.3	0	56.68	-	-	74	-17.32	224	212	V
2	* 2.484	47.65	Pk	32.3	-22.3	0	57.65	-	-	74	-16.35	224	212	V
3	* 2.484	26.42	RMS	32.3	-22.3	2.1	38.52	54	-15.48	-	-	224	212	V
4	* 2.485	29.91	RMS	32.3	-22.3	2.1	42.01	54	-11.99	-	-	224	212	V

* - indicates frequency in CFR47 Pt 15 / IC RSS-Restricted Band

Pk - Peak detector

RMS - RMS detection

7.2.3. HARMONICS AND SPURIOUS EMISSIONS ABOVE 1GHz

Low Channel Result

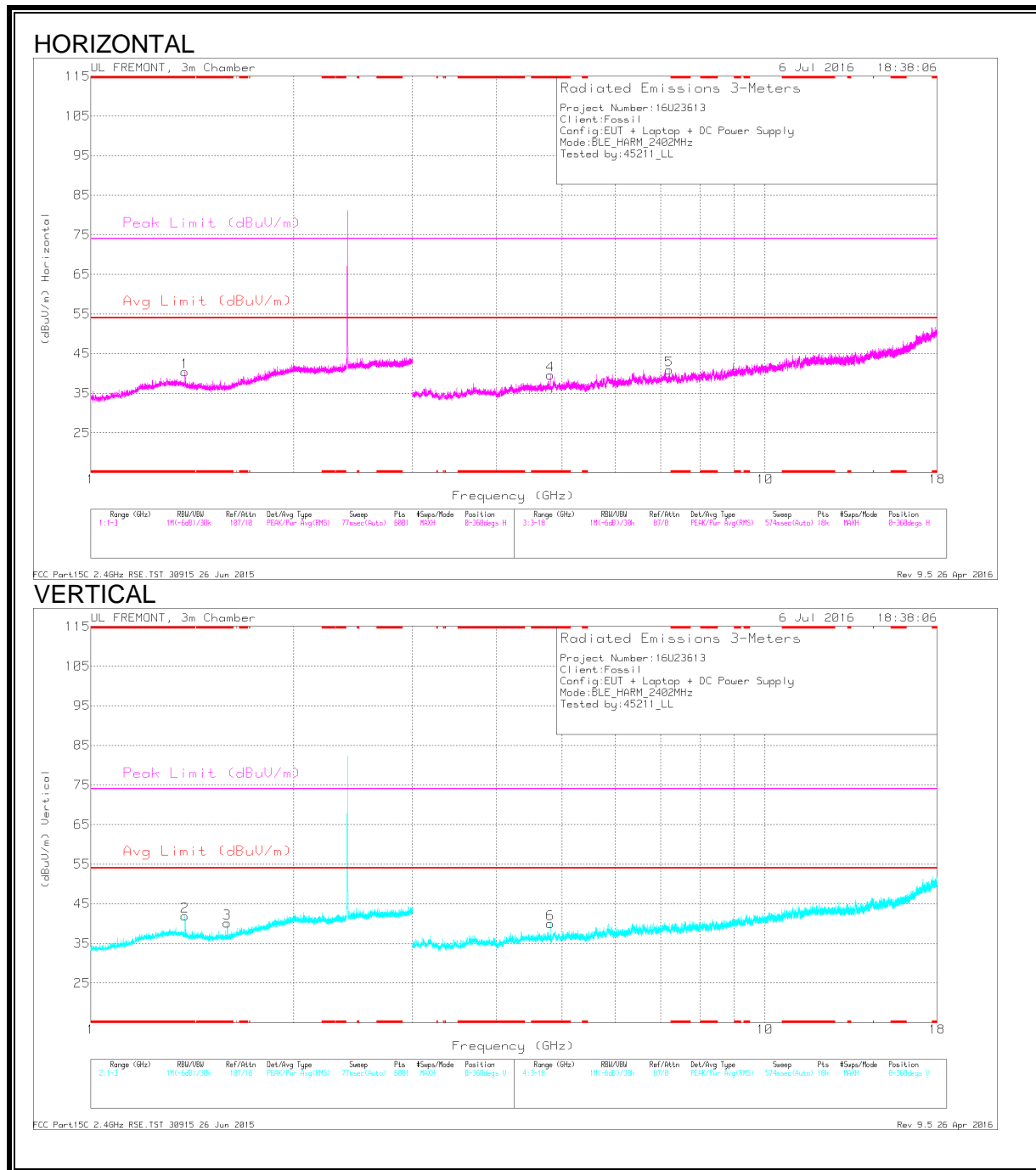

Trace Markers

Marker	Frequency (GHz)	Meter Reading (dBuV)	Det	AF T119 (dB/m)	Amp/Chl/Fitr/Pad (dB)	DC Corr (dB)	Corrected Reading (dBuV/m)	Avg Limit (dBuV/m)	Margin (dB)	Peak Limit (dBuV/m)	PK Margin (dB)	Azimuth (Degs)	Height (cm)	Polarity
1	* 1.38	31.57	Pk	29.1	-20.3	0	40.37	-	-	74	-33.63	0-360	200	H
2	* 1.38	33.1	Pk	29.1	-20.3	0	41.9	-	-	74	-32.1	0-360	200	V
3	* 1.594	32.49	Pk	27.9	-20.2	0	40.19	-	-	74	-33.81	0-360	200	V
4	* 4.804	32.79	Pk	34.2	-27.4	0	39.59	-	-	74	-34.41	0-360	200	H
6	* 4.804	33.23	Pk	34.2	-27.4	0	40.03	-	-	74	-33.97	0-360	100	V
5	7.206	31.17	Pk	35.7	-26	0	40.87	-	-	-	-	0-360	100	H

* - indicates frequency in CFR47 Pt 15 / IC RSS-Restricted Band
 Pk - Peak detector

Radiated Emissions

Frequency (GHz)	Meter Reading (dBuV)	Det	AF T119 (dB/m)	Amp/Chl/Fitr/Pad (dB)	DC Corr (dB)	Corrected Reading (dBuV/m)	Avg Limit (dBuV/m)	Margin (dB)	Peak Limit (dBuV/m)	PK Margin (dB)	Azimuth (Degs)	Height (cm)	Polarity
* 1.38	35.58	PK2	29.1	-20.3	0	44.38	-	-	74	-29.62	132	197	H
* 1.38	24.15	MAv1	29.1	-20.3	2.1	35.05	54	-18.95	-	-	132	197	H
* 1.38	35.55	PK2	29.1	-20.3	0	44.35	-	-	74	-29.65	203	135	V
* 1.38	25.58	MAv1	29.1	-20.3	2.1	36.48	54	-17.52	-	-	203	135	V
* 1.594	41.17	PK2	27.9	-20.1	0	48.97	-	-	74	-25.03	223	116	V
* 1.595	24.58	MAv1	27.9	-20.2	2.1	34.38	54	-19.62	-	-	223	116	V
* 4.804	40.13	PK2	34.2	-27.5	0	46.83	-	-	74	-27.17	12	330	H
* 4.804	31.85	MAv1	34.2	-27.4	2.1	40.75	54	-13.25	-	-	12	330	H
* 4.804	39.63	PK2	34.2	-27.5	0	46.33	-	-	74	-27.67	280	136	V
* 4.804	30.67	MAv1	34.2	-27.4	2.1	39.57	54	-14.43	-	-	280	136	V
7.206	31.17	Pk	35.7	-26	0	40.87	-	-	74	-33.13	0-360	100	H

* - indicates frequency in CFR47 Pt 15 / IC RSS-Restricted Band
 Pk - Peak detector
 PK2 - KDB558074 Method: Maximum Peak
 MAv1 - KDB558074 Option 1 Maximum RMS Average

Middle Channel Result

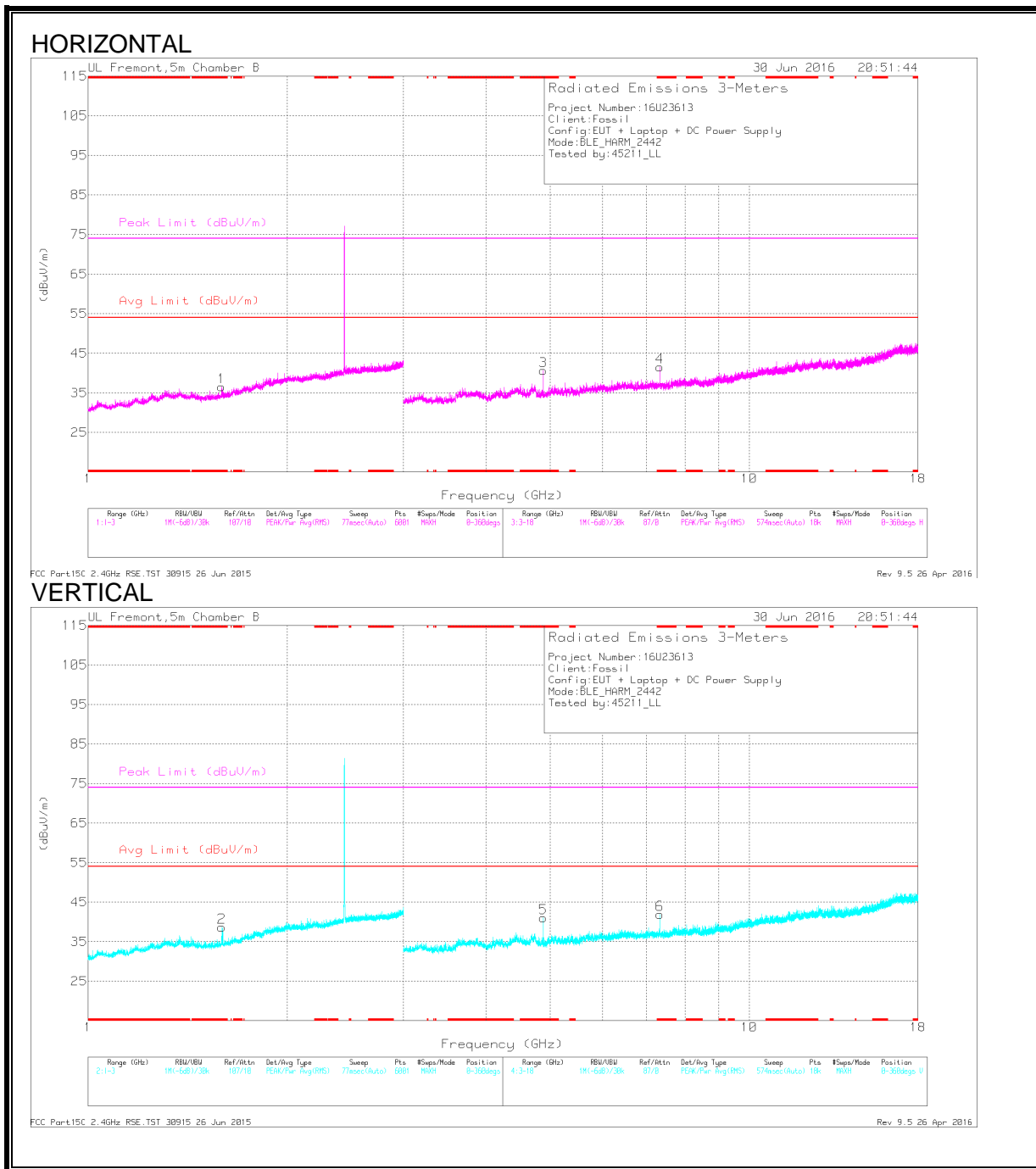

Trace Markers

Marker	Frequency (GHz)	Meter Reading (dBuV)	Det	AF T345 (dB/m)	Amp/Cb/Filt/Pad (dB)	DC Corr (dB)	Corrected Reading (dBuV/m)	Avg Limit (dBuV/m)	Margin (dB)	Peak Limit (dBuV/m)	PK Margin (dB)	Azimuth (Degs)	Height (cm)	Polarity
1	* 1.593	30.75	Pk	28.1	-22.3	0	36.55	-	-	74	-37.45	0-360	199	H
2	* 1.593	32.89	Pk	28.1	-22.3	0	38.69	-	-	74	-35.31	0-360	199	V
3	* 4.884	39.65	Pk	33.8	-32.8	0	40.65	-	-	74	-33.35	0-360	101	H
4	* 7.325	36.26	Pk	35.6	-30.3	0	41.56	-	-	74	-32.44	0-360	101	H
5	* 4.884	40.07	Pk	33.8	-32.8	0	41.07	-	-	74	-32.93	0-360	101	V
6	* 7.325	36.63	Pk	35.6	-30.3	0	41.93	-	-	74	-32.07	0-360	101	V

* - indicates frequency in CFR47 Pt 15 / IC RSS-Restricted Band
 Pk - Peak detector

Radiated Emissions

Frequency (GHz)	Meter Reading (dBuV)	Det	AF T345 (dB/m)	Amp/Cb/Filt/Pad (dB)	DC Corr (dB)	Corrected Reading (dBuV/m)	Avg Limit (dBuV/m)	Margin (dB)	Peak Limit (dBuV/m)	PK Margin (dB)	Azimuth (Degs)	Height (cm)	Polarity
* 1.594	38.99	PK2	28.1	-22.3	0	44.79	-	-	74	-29.21	63	247	H
* 1.593	24.53	MAv1	28.1	-22.3	2.1	32.43	54	-21.57	-	-	63	247	H
* 1.593	36.98	PK2	28.1	-22.3	0	42.78	-	-	74	-31.22	160	183	V
* 1.594	24.37	MAv1	28.1	-22.3	2.1	32.27	54	-21.73	-	-	160	183	V
* 4.884	43.98	PK2	33.8	-32.8	0	44.98	-	-	74	-29.02	116	133	H
* 4.884	35.63	MAv1	33.8	-32.8	2.1	38.73	54	-15.27	-	-	116	133	H
* 7.326	41.58	PK2	35.6	-30.3	0	46.88	-	-	74	-27.12	121	252	H
* 7.325	31.64	MAv1	35.6	-30.3	2.1	39.04	54	-14.96	-	-	121	252	H
* 4.884	42.77	PK2	33.8	-32.8	0	43.77	-	-	74	-30.23	161	110	V
* 4.884	33.86	MAv1	33.8	-32.8	2.1	36.96	54	-17.04	-	-	161	110	V
* 7.327	42.12	PK2	35.6	-30.3	0	47.42	-	-	74	-26.58	168	101	V
* 7.325	32.5	MAv1	35.6	-30.3	2.1	39.9	54	-14.1	-	-	168	101	V

* - indicates frequency in CFR47 Pt 15 / IC RSS-Restricted Band
 PK2 - KDB558074 Method: Maximum Peak
 MAv1 - KDB558074 Option 1 Maximum RMS Average

High Channel Result

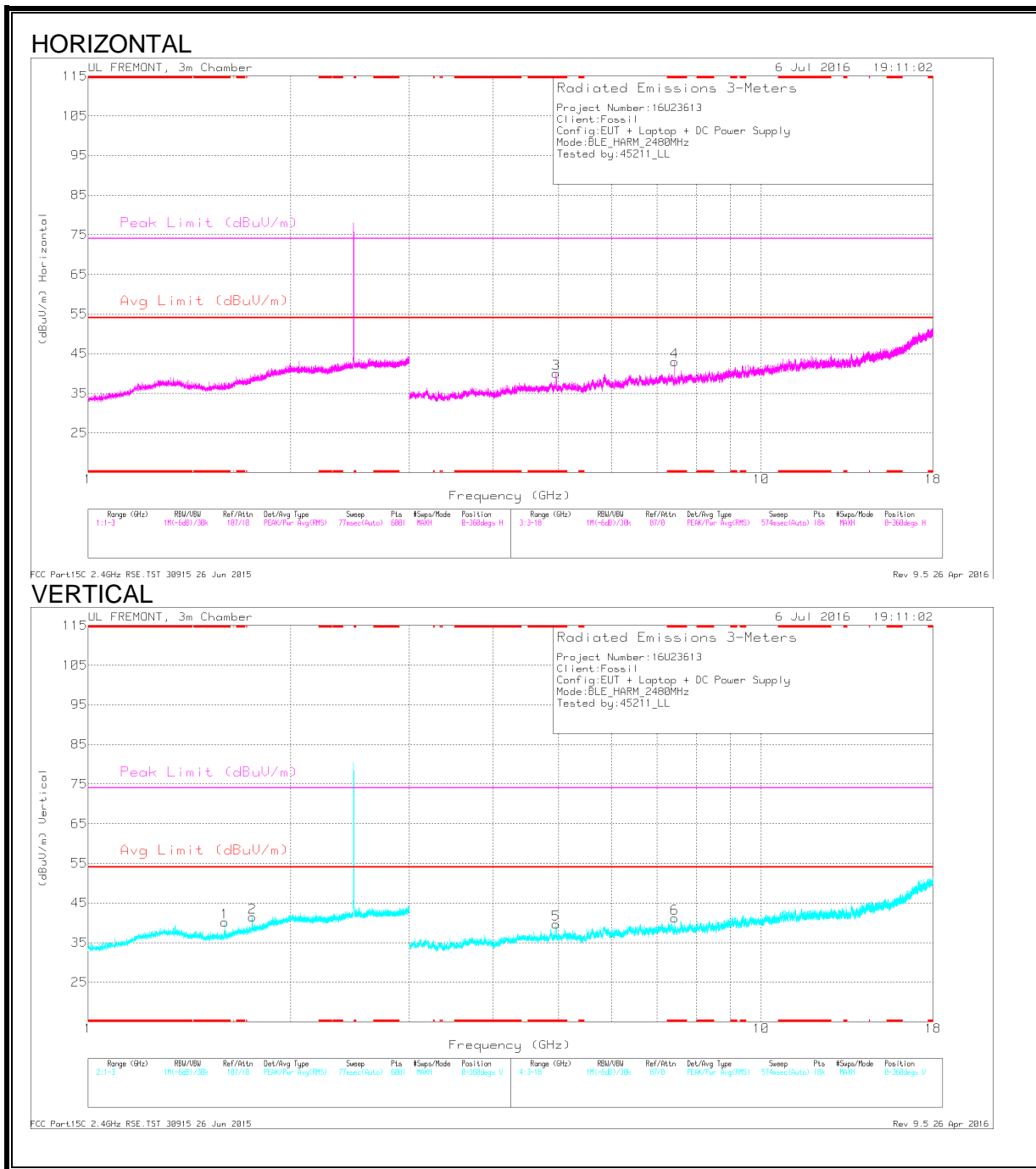

Trace Markers

Marker	Frequency (GHz)	Meter Reading (dBuV)	Det	AF T119 (dB/m)	Amp/Ch/Filter/Pad (dB)	DC Corr (dB)	Corrected Reading (dBuV/m)	Avg Limit (dBuV/m)	Margin (dB)	Peak Limit (dBuV/m)	PK Margin (dB)	Azimuth (Degs)	Height (cm)	Polarity
1	* 1.595	32.39	Pk	27.9	-20.2	0	40.09	-	-	74	-33.91	0-360	100	V
3	* 4.959	33.21	Pk	34.2	-27.4	0	40.01	-	-	74	-33.99	0-360	200	H
4	* 7.44	32.57	Pk	35.7	-25.3	0	42.97	-	-	74	-31.03	0-360	100	H
5	* 4.959	32.83	Pk	34.2	-27.4	0	39.63	-	-	74	-34.37	0-360	100	V
6	* 7.44	30.75	Pk	35.7	-25.3	0	41.15	-	-	74	-32.85	0-360	100	V
2	1.753	31.51	Pk	29.7	-19.8	0	41.41	-	-	-	-	0-360	200	V

* - indicates frequency in CFR47 Pt 15 / IC RSS-Restricted Band
 Pk - Peak detector

Radiated Emissions

Frequency (GHz)	Meter Reading (dBuV)	Det	AF T119 (dB/m)	Amp/Ch/Filter/Pad (dB)	DC Corr (dB)	Corrected Reading (dBuV/m)	Avg Limit (dBuV/m)	Margin (dB)	Peak Limit (dBuV/m)	PK Margin (dB)	Azimuth (Degs)	Height (cm)	Polarity
* 1.596	41.48	PK2	28	-20	0	49.48	-	-	74	-24.52	207	177	V
* 1.595	24.58	MAv1	27.9	-20.2	2.1	34.38	54	-19.62	-	-	207	177	V
* 4.96	41.72	PK2	34.2	-27.4	0	48.52	-	-	74	-25.48	23	281	H
* 4.96	32.86	MAv1	34.2	-27.4	2.1	41.76	54	-12.24	-	-	23	281	H
* 7.439	38.61	PK2	35.7	-25.4	0	48.91	-	-	74	-25.09	347	100	H
* 7.439	29.32	MAv1	35.7	-25.3	2.1	41.82	54	-12.18	-	-	347	100	H
* 4.96	39.01	PK2	34.2	-27.4	0	45.81	-	-	74	-28.19	299	101	V
* 4.96	29.83	MAv1	34.2	-27.4	2.1	38.73	54	-15.27	-	-	299	101	V
* 7.439	37.03	PK2	35.7	-25.3	0	47.43	-	-	74	-26.57	314	332	V
* 7.439	27.14	MAv1	35.7	-25.4	2.1	39.54	54	-14.46	-	-	314	332	V
1.753	31.51	Pk	29.7	-19.8	0	41.41	-	-	74	-32.59	0-360	200	V

* - indicates frequency in CFR47 Pt 15 / IC RSS-Restricted Band
 Pk - Peak detector
 PK2 - KDB558074 Method: Maximum Peak
 MAv1 - KDB558074 Option 1 Maximum RMS Average

7.2.1. WORST-CASE BELOW 30 MHz

SPURIOUS EMISSIONS BELOW 30 MHz

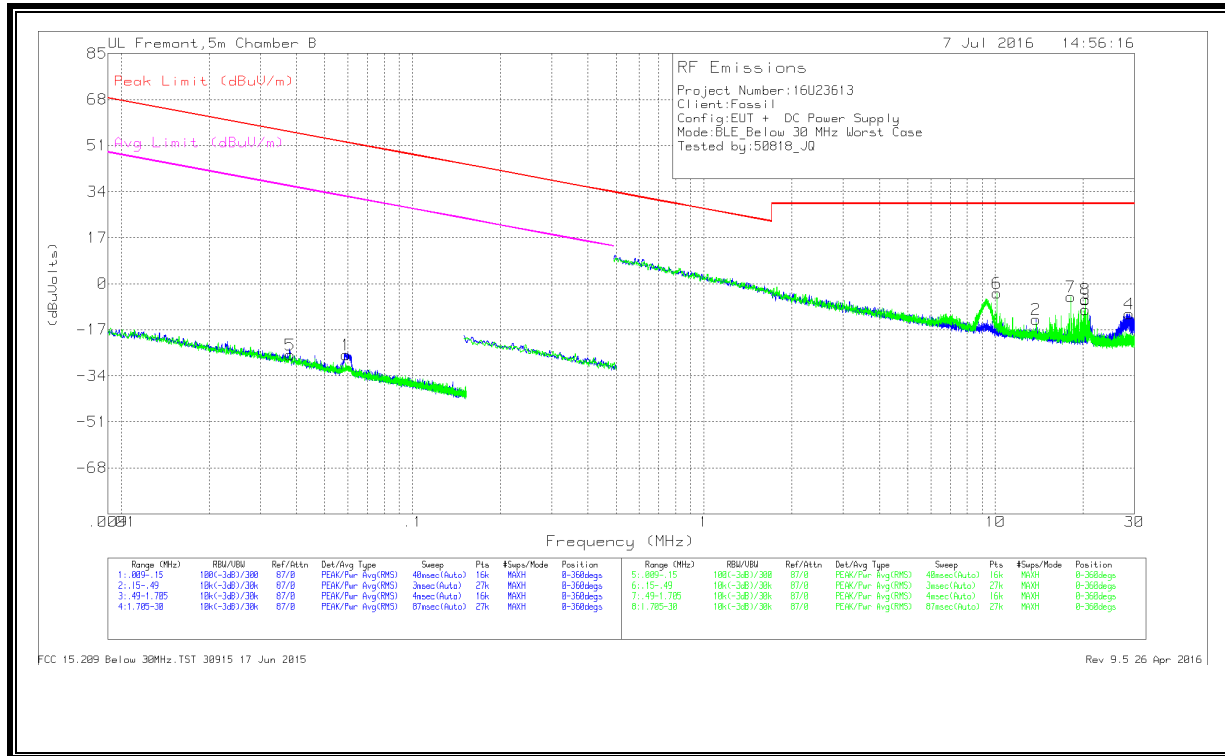

Trace Markers

Marker	Frequency (MHz)	Meter Reading (dBuV)	Det	Loop Antenna (dB/m)	Cbl (dB)	Dist Corr 300m	Corrected Reading (dBuV)	Peak Limit (dBuV/m)	Margin (dB)	Avg Limit (dBuV/m)	Margin (dB)	Azimuth (Degs)
5	.03798	40.04	Pk	12.3	1.4	-80	-26.26	56.01	-82.27	36.01	-62.27	0-360
1	.05909	41.06	Pk	11.2	1.4	-80	-26.34	52.17	-78.51	32.17	-58.51	0-360

Pk - Peak detector

Marker	Frequency (MHz)	Meter Reading (dBuV)	Det	Loop Antenna (dB/m)	Cbl (dB)	Dist Corr 30m	Corrected Reading (dBuV)	Peak Limit (dBuV/m)	Margin (dB)	Avg Limit (dBuV/m)	Margin (dB)	Azimuth (Degs)
6	10.10682	24.08	Pk	10.8	1.6	-40	-3.52	29.54	-33.06	-	-	0-360
2	13.79106	14.69	Pk	10.6	1.6	-40	-13.11	29.54	-42.65	-	-	0-360
7	18.16279	23.18	Pk	10.3	1.6	-40	-4.92	29.54	-34.46	-	-	0-360
3	20.37617	18.81	Pk	10	1.7	-40	-9.49	29.54	-39.03	-	-	0-360
8	20.37722	22.62	Pk	10	1.7	-40	-5.68	29.54	-35.22	-	-	0-360
4	28.77274	18.79	Pk	8.3	1.7	-40	-11.21	29.54	-40.75	-	-	0-360

Pk - Peak detector

7.2.2. WORST-CASE BELOW 1 GHz

SPURIOUS EMISSIONS 30 TO 1000 MHz

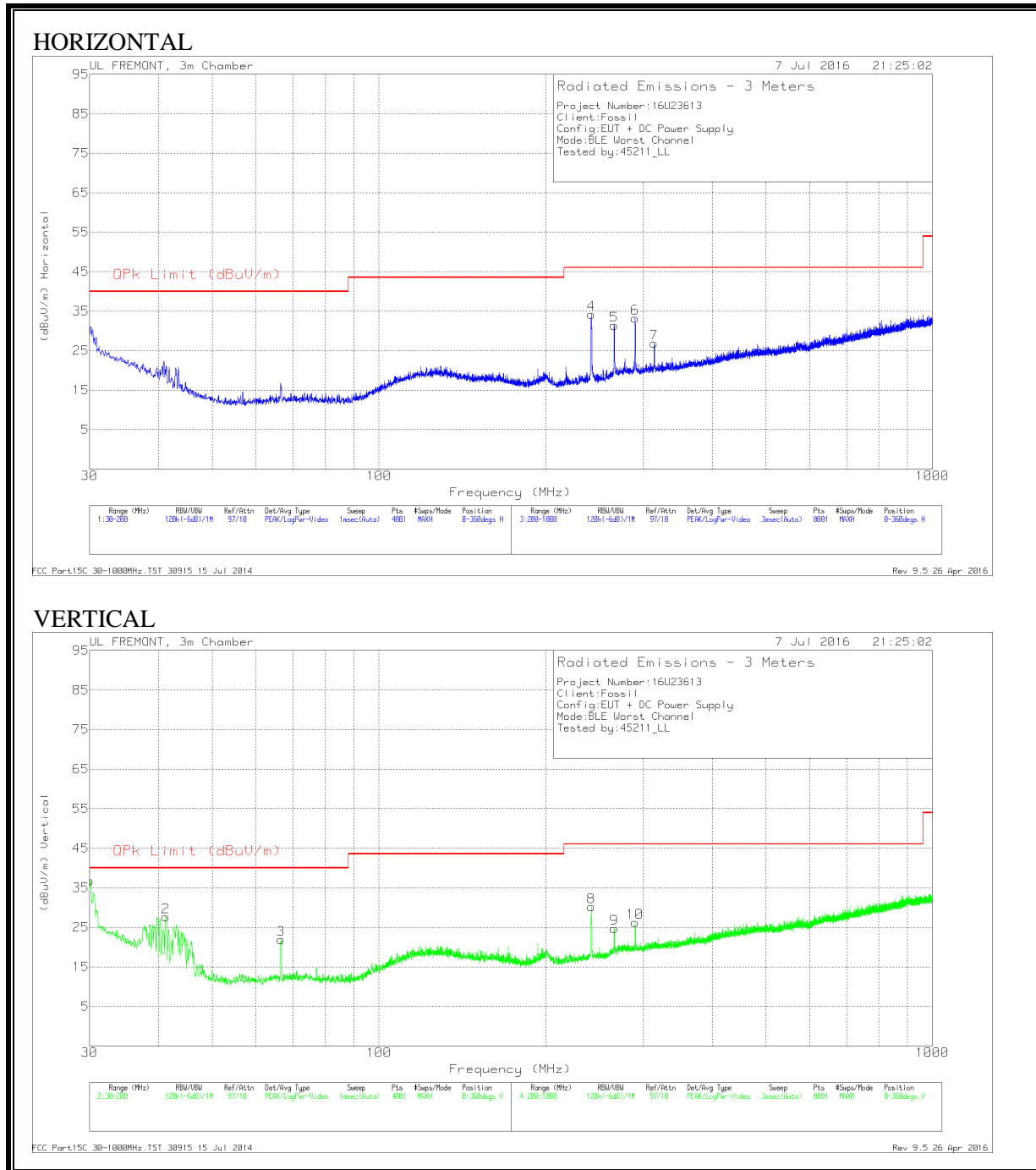

Trace Markers

Marker	Frequency (MHz)	Meter Reading (dBuV)	Det	AF T122 (dB/m)	Amp/Cbl (dB)	Corrected Reading (dBuV/m)	QPk Limit (dBuV/m)	Margin (dB)	Azimuth (Degs)	Height (cm)	Polarity
1	30.085	38.84	Pk	25.2	-27.3	36.74	40	-3.26	0-360	100	V
	30.085	25.88	Qp	25.1	-27.2	23.78	40	-16.22	22	108	V
2	41.1988	37.76	Pk	16.9	-27	27.66	40	-12.34	0-360	100	V
3	66.55	36.68	Pk	11.9	-26.7	21.88	40	-18.12	0-360	100	V
4	242	43.47	Pk	15.5	-24.7	34.27	46.02	-11.75	0-360	100	H
5	266.1	39.17	Pk	16.8	-24.5	31.47	46.02	-14.55	0-360	100	H
6	290.2	40.27	Pk	17.3	-24.4	33.17	46.02	-12.85	0-360	100	H
7	314.4	33.53	Pk	17.7	-24.4	26.83	46.02	-19.19	0-360	100	H
8	242	39.33	Pk	15.5	-24.7	30.13	46.02	-15.89	0-360	200	V
9	266.1	32.38	Pk	16.8	-24.5	24.68	46.02	-21.34	0-360	200	V
10	290.3	33.36	Pk	17.3	-24.4	26.26	46.02	-19.76	0-360	200	V

Pk - Peak detector

Qp - Quasi-Peak detector

7.2.3. WORST-CASE ABOVE 18 GHz

SPURIOUS EMISSIONS 18 TO 26 GHz

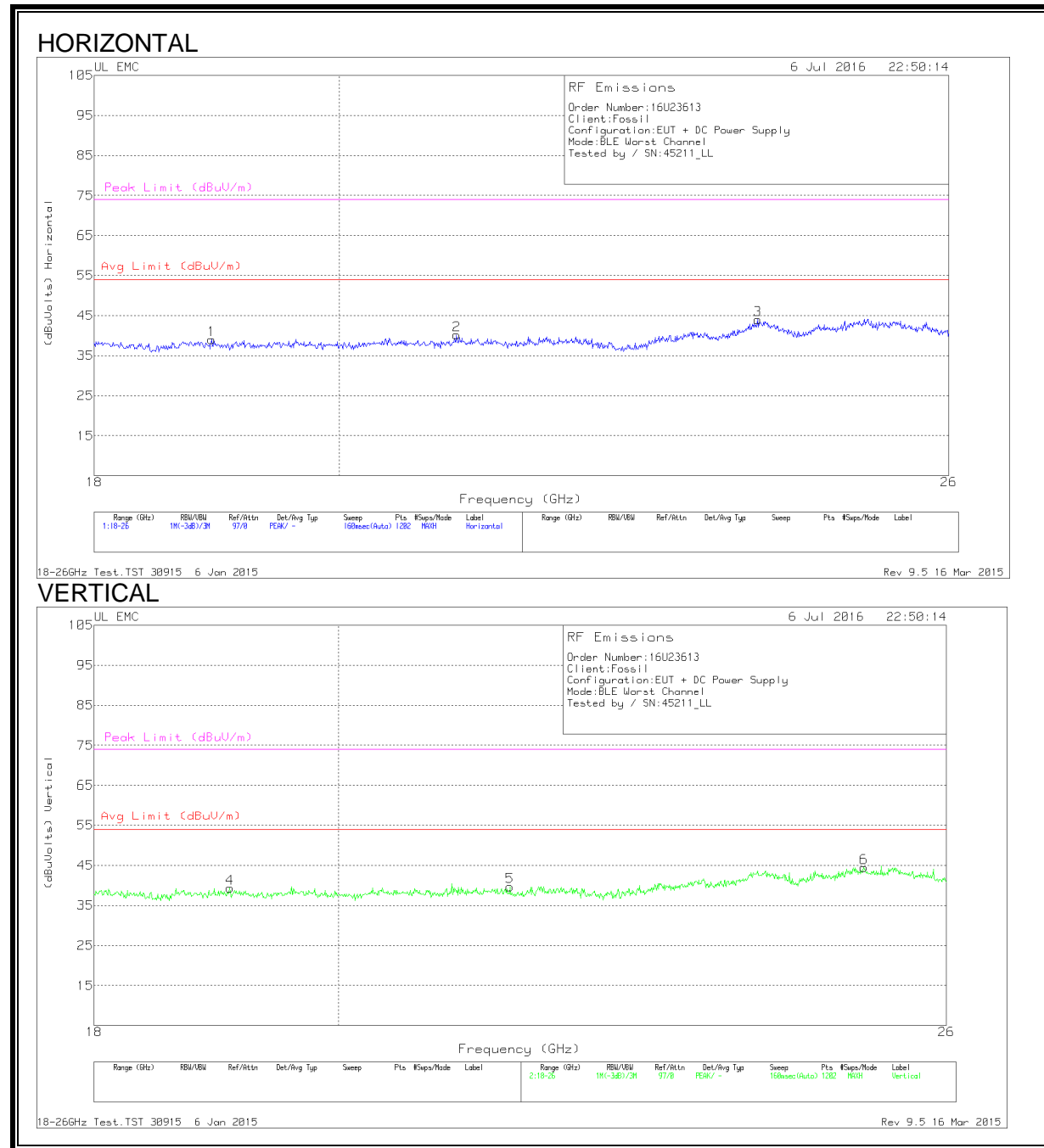

Trace Markers

Marker	Frequency (GHz)	Meter Reading (dBuV)	Det	AF T449 (dB/m)	Amp/Cbl (dB)	Dist Corr (dB)	Corrected Reading (dBuVolts)	Avg Limit (dBuV/m)	Margin (dB)	Peak Limit (dBuV/m)	PK Margin (dB)
1	18.933	41.3	Pk	32.5	-25.3	-9.5	39	54	-15	74	-35
2	21.037	41.77	Pk	33.1	-25.2	-9.5	40.17	54	-13.83	74	-33.83
3	23.948	43.8	Pk	34	-24.3	-9.5	44	54	-10	74	-30
4	19.086	41.13	Pk	32.6	-24.9	-9.5	39.33	54	-14.67	74	-34.67
5	21.537	41.17	Pk	33.2	-25.2	-9.5	39.67	54	-14.33	74	-34.33
6	25.087	44.2	Pk	34.3	-24.5	-9.5	44.5	54	-9.5	74	-29.5

Pk - Peak detector