



**FCC 47 CFR PART 15 SUBPART C
INDUSTRY CANADA RSS-210 ISSUE 8**

CERTIFICATION TEST REPORT

FOR

PEDOMETER

MODEL NUMBER: NDJ3a, NDJ3b, NDJ3c, NDJ3d

FCC ID: UK7-NDJ3

IC: 6708A-NDJ3

REPORT NUMBER: 16U23612-E1V4

ISSUE DATE: AUGUST 2, 2016

Prepared for

Fossil Group, Inc.

901 S. Central Expressway

Richardson, TX 75080 U.S.A.

Prepared by

UL VERIFICATION SERVICES INC.

47173 BENICIA STREET

FREMONT, CA 94538, U.S.A.

TEL: (510) 771-1000

FAX: (510) 661-0888



NVLAP LAB CODE 200065-0

Revision History

Rev.	Issue Date	Revisions	Revised By
V1	07/22/16	Initial Issue	C. Vergonio
V2	07/31/16	Updated Page 1 and 4.	C. Vergonio
V3	08/01/16	Updated Section 6.4, 8.1, and 8.2.	C. Vergonio
V4	08/02/16	Updated Section 8.2.1	C. Vergonio

TABLE OF CONTENTS

1. ATTESTATION OF TEST RESULTS	4
2. TEST METHODOLOGY	5
3. FACILITIES AND ACCREDITATION	5
4. CALIBRATION AND UNCERTAINTY	5
4.1. <i>MEASURING INSTRUMENT CALIBRATION</i>	5
4.2. <i>SAMPLE CALCULATION</i>	5
4.3. <i>MEASUREMENT UNCERTAINTY</i>	6
5. SUMMARY TABLE	7
6. EQUIPMENT UNDER TEST	8
6.1. <i>DESCRIPTION OF EUT</i>	8
6.2. <i>MODEL DIFFERENCES</i>	8
6.3. <i>MAXIMUM OUTPUT E-FIELD STRENGTH</i>	9
6.4. <i>DESCRIPTION OF AVAILABLE ANTENNAS</i>	9
6.5. <i>SOFTWARE AND FIRMWARE</i>	9
6.6. <i>WORST-CASE CONFIGURATION AND MODE</i>	9
6.7. <i>DESCRIPTION OF TEST SETUP</i>	10
7. TEST AND MEASUREMENT EQUIPMENT	12
8. TEST RESULTS	13
8.1. <i>ANTENNA PORT TEST RESULTS</i>	13
8.1.1. <i>ON TIME AND DUTY CYCLE</i>	13
8.1.2. <i>99% & 6 dB BANDWIDTH</i>	14
8.2. <i>RADIATED EMISSIONS</i>	17
8.2.1. <i>FUNDAMENTAL FREQUENCY RADIATED EMISSION</i>	18
8.2.2. <i>TRANSMITTER RESTRICTED BAND EDGES</i>	19
8.2.3. <i>HARMONICS AND SPURIOUS EMISSIONS ABOVE 1GHz</i>	23
8.2.1. <i>WORST-CASE BELOW 30 MHz</i>	29
8.2.2. <i>WORST-CASE BELOW 1 GHz</i>	30
8.2.3. <i>WORST-CASE ABOVE 18 GHz</i>	32
9. SETUP PHOTOS	34

1. ATTESTATION OF TEST RESULTS

COMPANY NAME: Fossil Group, Inc.
901 S. Central Expressway
Richardson, TX 75080 U.S.A.

EUT DESCRIPTION: PEDOMETER

MODEL: NDJ3a, NDJ3b, NDJ3c, NDJ3d

SERIAL NUMBER: 14-07419-000

DATE TESTED: July 19 to August 1, 2016

APPLICABLE STANDARDS	
STANDARD	TEST RESULTS
CFR 47 Part 15 Subpart C	Pass
INDUSTRY CANADA RSS-210 Issue 8	Pass
INDUSTRY CANADA RSS-GEN Issue 4	Pass

UL Verification Services Inc. tested the above equipment in accordance with the requirements set forth in the above standards. All indications of Pass/Fail in this report are opinions expressed by UL Verification Services Inc. based on interpretations and/or observations of test results. Measurement Uncertainties were not taken into account and are published for informational purposes only. The test results show that the equipment tested is capable of demonstrating compliance with the requirements as documented in this report.

Note: The results documented in this report apply only to the tested sample, under the conditions and modes of operation as described herein. This document may not be altered or revised in any way unless done so by UL Verification Services Inc. and all revisions are duly noted in the revisions section. Any alteration of this document not carried out by UL Verification Services Inc. will constitute fraud and shall nullify the document. This report must not be used by the client to claim product certification, approval, or endorsement by NVLAP, NIST, any agency of the Federal Government, or any agency of any government.

Approved & Released For
UL Verification Services Inc. By:

Prepared By:



CHARLES VERGONIO
WiSE ENGINEER
UL Verification Services Inc.

JASON QIAN
WiSE LAB ENGINEER
UL Verification Services Inc.

2. TEST METHODOLOGY

The tests documented in this report were performed in accordance with ANSI C63.10-2013, FCC CFR 47 Part 2, FCC CFR 47 Part 15, RSS-GEN Issue 4, and RSS-210.

3. FACILITIES AND ACCREDITATION

The test sites and measurement facilities used to collect data are located at 47173 Benicia Street, Fremont, California, USA.

The test sites and measurement facilities used to collect data are located at 47173 and 47266 Benicia Street, Fremont, California, USA. Line conducted emissions are measured only at the 47173 address. The following table identifies which facilities were utilized for radiated emission measurements documented in this report. Specific facilities are also identified in the test results sections.

47173 Benicia Street	47266 Benicia Street
<input type="checkbox"/> Chamber A	<input type="checkbox"/> Chamber D
<input checked="" type="checkbox"/> Chamber B	<input type="checkbox"/> Chamber E
<input type="checkbox"/> Chamber C	<input type="checkbox"/> Chamber F
	<input type="checkbox"/> Chamber G
	<input type="checkbox"/> Chamber H

The above test sites and facilities are covered under FCC Test Firm Registration # 208313. Chambers A through H are covered under Industry Canada company address code 2324B with site numbers 2324B -1 through 2324B-8, respectively.

UL Verification Services Inc. is accredited by NVLAP, Laboratory Code 200065-0. The full scope of accreditation can be viewed at <http://ts.nist.gov/standards/scopes/2000650.htm>.

4. CALIBRATION AND UNCERTAINTY

4.1. MEASURING INSTRUMENT CALIBRATION

The measuring equipment utilized to perform the tests documented in this report has been calibrated in accordance with the manufacturer's recommendations, and is traceable to recognized national standards.

4.2. SAMPLE CALCULATION

Where relevant, the following sample calculation is provided:

$$\begin{aligned} \text{Field Strength (dBuV/m)} &= \text{Measured Voltage (dBuV)} + \text{Antenna Factor (dB/m)} + \\ &\text{Cable Loss (dB)} - \text{Preamp Gain (dB)} \\ 36.5 \text{ dBuV} + 18.7 \text{ dB/m} + 0.6 \text{ dB} - 26.9 \text{ dB} &= 28.9 \text{ dBuV/m} \end{aligned}$$

4.3. MEASUREMENT UNCERTAINTY

Where relevant, the following measurement uncertainty levels have been estimated for tests performed on the apparatus:

PARAMETER	UNCERTAINTY
Conducted Disturbance, 9KHz to 0.15 MHz	3.84 dB
Conducted Disturbance, 0.15 to 30 MHz	3.65 dB
Radiated Disturbance, 9KHz to 30 MHz	3.15 dB
Radiated Disturbance, 30 to 1000 MHz	5.36 dB
Radiated Disturbance, 1000 to 18000 MHz	4.32 dB
Radiated Disturbance, 18000 to 26000 MHz	4.45 dB

Uncertainty figures are valid to a confidence level of 95%.

5. SUMMARY TABLE

FCC Part Section	RSS Section(s)	Test Description	Test Limit	Test Condition	Test Result
15.249 (c)	RSS-210	Fundamental Emission	<50mV/m	Radiated	Pass
15.205, 15.209, 15.249	RSS-GEN 8.9/7	Radiated Spurious Emission	< 54dBuV/m		Pass

6. EQUIPMENT UNDER TEST

6.1. DESCRIPTION OF EUT

The EUT is a PEDOMETER. Model Number: NDJ3a covers Michael Kors Crosby, Model Number: NDJ3b covers Michael Kors Reade, Model Number: NDJ3c covers Kate Spade Cat, and Model Number: NDJ3d covers Kate Spade Scallop.

6.2. MODEL DIFFERENCES

According to Manufacturer Attestation Letter, unlicensed radio is electrically identical and the PCBA are identical in all models. They share the same chipset, same power and same antenna performance including antenna gain.

6.3. MAXIMUM OUTPUT E-FIELD STRENGTH

The transmitter has a maximum output peak E-field as follows:

Frequency Range (MHz)	Mode	Output PK E-field Strength (dBuV/m)
2402-2480	BLE	90.88

6.4. DESCRIPTION OF AVAILABLE ANTENNAS

The radio utilizes a Loop Trace antenna, with a maximum gain of -2.71 dBi.

6.5. SOFTWARE AND FIRMWARE

The test utility software used during testing was Connection Manager by Dialog Semiconductor, rev. 3.0.10.

6.6. WORST-CASE CONFIGURATION AND MODE

Radiated emission was performed with the EUT set to transmit at the channel with highest output power as worst-case scenario.

Worst-Case was investigated on Radiated Fundamental and Bandedge testing for all models and styles. Model NDJ3D was determined to be worst-case. Emissions testing were performed on this model.

The fundamental of the EUT was investigated in three orthogonal orientations X, Y, Z, it was determined that Y orientation was worst-case orientation; therefore, all final radiated testing was performed with the EUT in Y orientation.

6.7. DESCRIPTION OF TEST SETUP

SUPPORT EQUIPMENT

Support Equipment List			
Description	Manufacturer	Model	Serial Number
Laptop	Lenovo	2349CW5	PBB4M4Y
AC Adapter	Lenovo	ADLX90NLT2A	N/A
Laptop	HP	Pavilion/TPN-Q121	6CF3473G6S
AC Adapter	HP	709985-002	F240061328020397
DC Power Supply	Sorensen	XT 20-3	1318A00530

I/O CABLES

I/O Cable List						
Cable No	Port	# of identical ports	Connector Type	Cable Type	Cable Length (m)	Remarks
1	USB	1	USB-Serial	Shielded	1.8	EUT to Laptop
2	DC	1	Banana Plug	Shielded	0.5m	EUT to DC Power Supply
3	AC	1	3-prong	Shielded	1.5m	Laptop to AC Mains
4	AC	1	3-prong	Shielded	1.5m	Power Supply to AC Mains

TEST SETUP

The EUT is connected with a host laptop computer by USB to Serial cable during the tests, test software exercised the radio.

SETUP DIAGRAM FOR TESTS

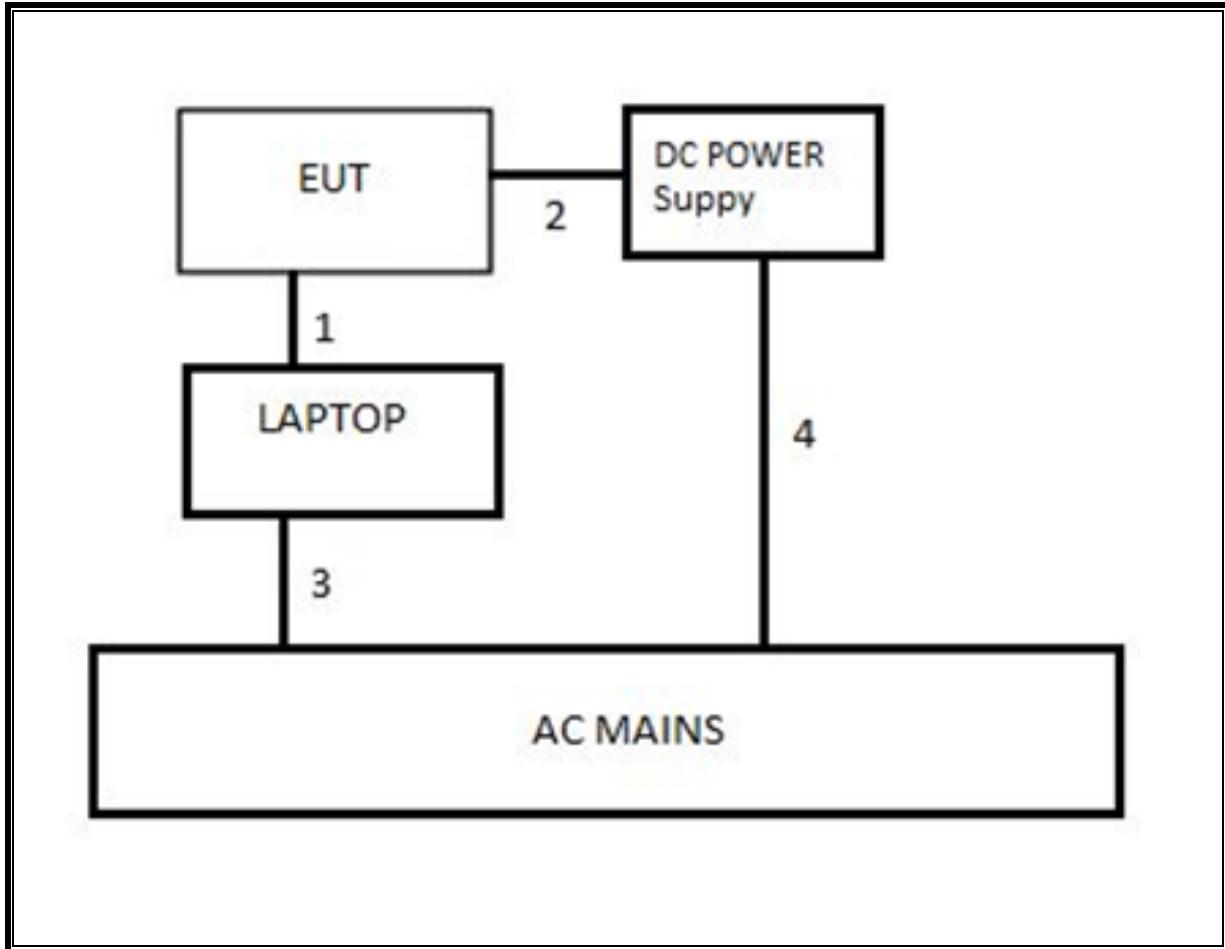

7. TEST AND MEASUREMENT EQUIPMENT

The following test and measurement equipment was utilized for the tests documented in this report:

Test Equipment List				
Description	Manufacturer	Model	T Number	Cal Due
Antenna, Biconolog, 30MHz-1 GHz	Sunol Sciences	JB1	130	09/01/16
Antenna, Horn, 18GHz	ETS Lindgren	3117	119	02/04/17
Antenna, Horn, 18GHz	ETS Lindgren	3117	345	03/07/17
Antenna, Horn, 26.5 GHz	ARA	MWH-1826/B	447	06/16/17
Antenna, Loop, 9KHz to 30MHz	EMCO	80465	35	03/24/17
High Pass Filter 3GHz	Microtronics	HPM17543	485	03/09/17
RF Preamplifier, 18GHz - 26.5GHz	HP	8449B	404	11/29/16
RF Preamplifier, 1GHz - 18GHz	Miteq	NSP4000-SP2	493	04/07/17
RF Preamplifier, 1GHz - 8GHz	Miteq	AMF-4D-01000800-30-29p	1156	03/09/17
RF Preamplifier, 30MHz - 1GHz	HP	8447D	15	08/14/16
Spectrum Analyzer, 40 GHz	Agilent / HP	8564E	106	08/07/16
Spectrum Analyzer, 44 GHz	Agilent / HP	E4446A	123	10/22/16
Spectrum Analyzer, PXA3Hz to 44GHz	Keysight	N9030A	907	01/06/17

Test Software List			
Description	Manufacturer	Model	Version
Radiated Software	UL	UL EMC	Ver 9.5, Apr 26, 2016
Conducted Software	UL	UL EMC	Ver 9.5, May 26, 2015
Conducted Port Software	UL	UL RF	Ver 5.1.1, July 15, 2016

8. TEST RESULTS

8.1. ANTENNA PORT TEST RESULTS

8.1.1. ON TIME AND DUTY CYCLE

LIMITS

None; for reporting purposes only.

RESULTS

Mode	ON Time B (msec)	Period (msec)	Duty Cycle x (linear)	Duty Cycle (%)	Duty Cycle Correction Factor (dB)
BLE	0.3880	0.6250	0.621	62.08%	2.07

DUTY CYCLE PLOT

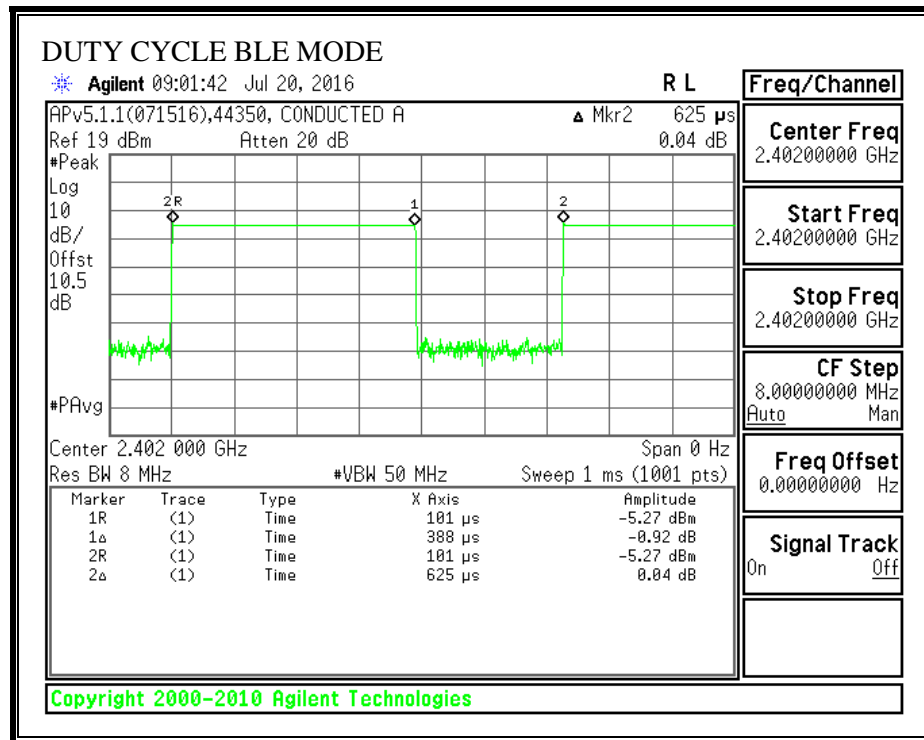

8.1.2. 99% & 20 dB BANDWIDTH

LIMITS

None; for reporting purposes only.

RESULTS

Frequency (MHz)	99% Bandwidth (MHz)	20dB Bandwidth (MHz)
2402	1.0741	1.192
2442	1.0746	1.201
2480	1.075	1.197

99% & 20dB BANDWIDTH

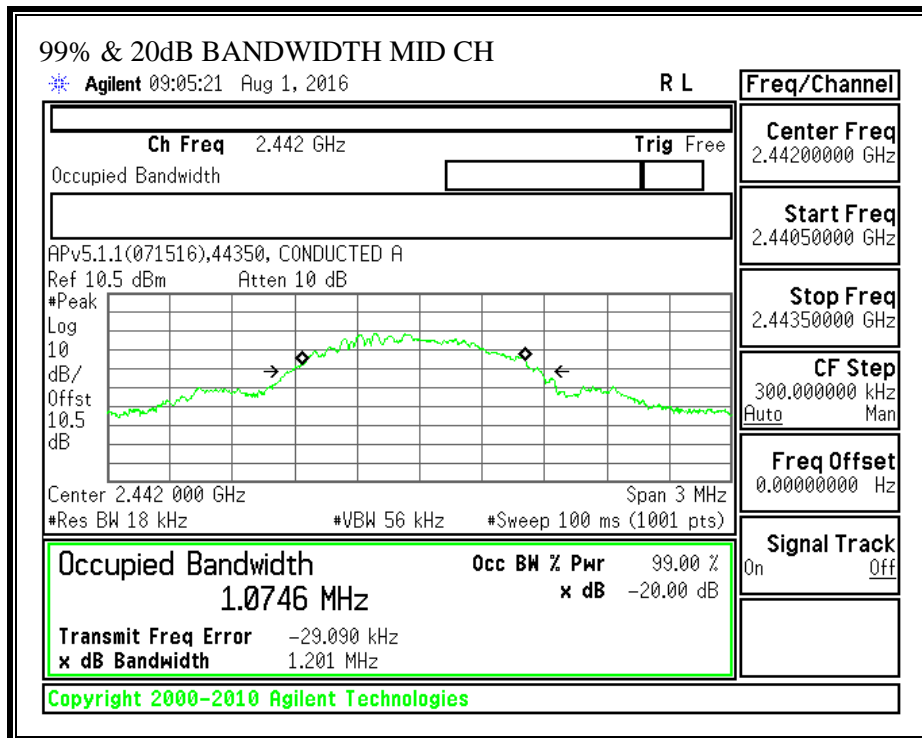
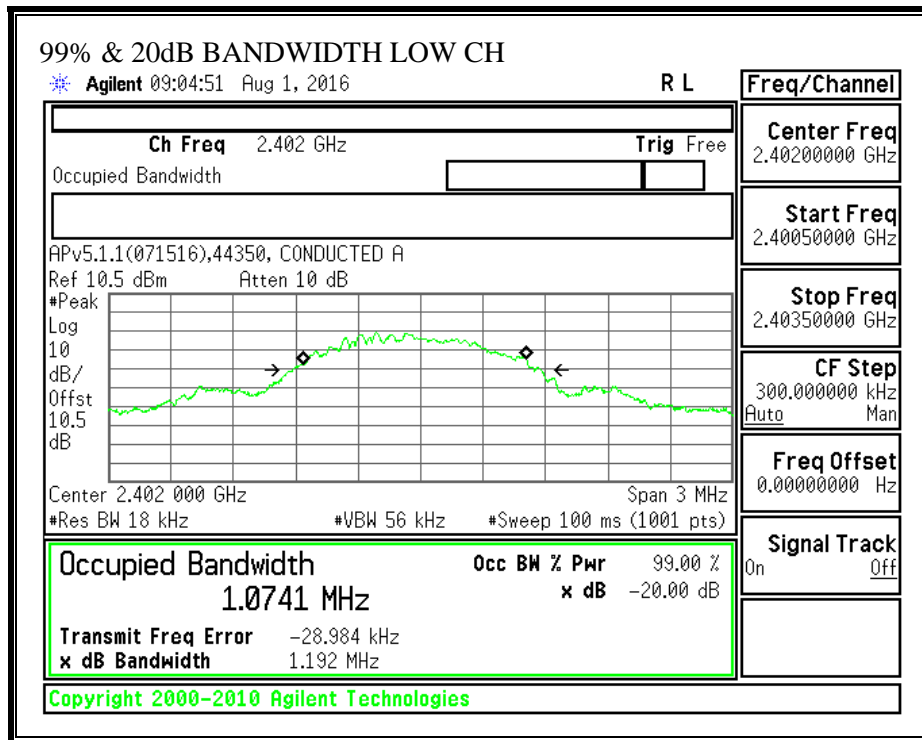

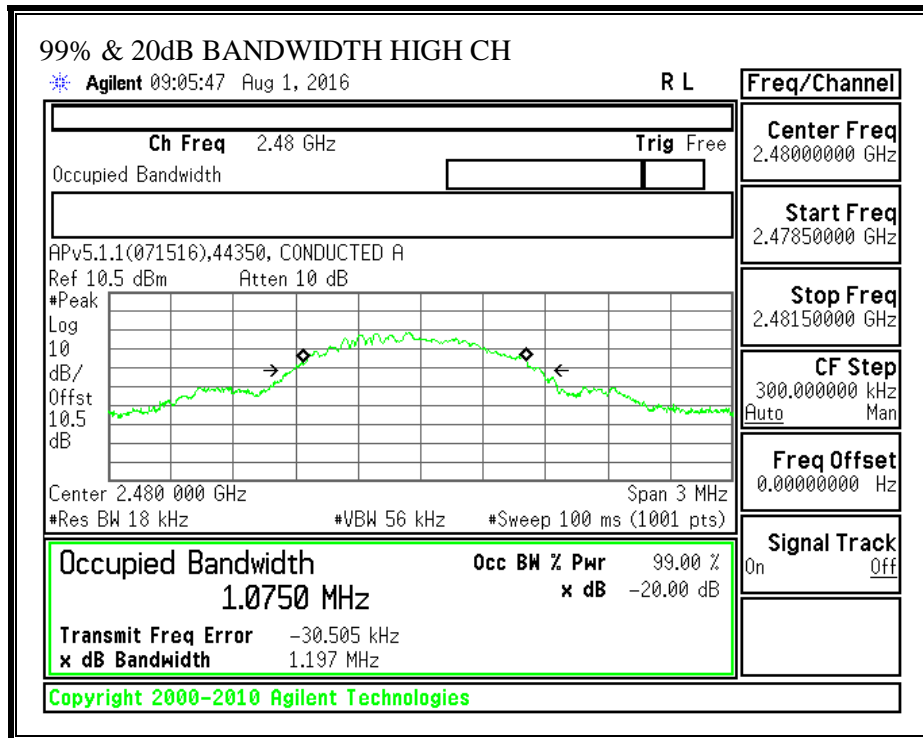

8.2. RADIATED EMISSIONS

LIMIT

FCC 15.249

IC RSS-210
 IC RSS-GEN Clause 8.9 (Transmitter)
 IC RSS-GEN Clause 7 (Receiver)

Operation within the bands 902–928 MHz, 2400–2483.5 MHz, 5725–5875 MHz, and 24.0–24.25 GHz.

(a) Except as provided in paragraph (b) of this section, the field strength of emissions from intentional radiators operated within these frequency bands shall comply with the following:

Fundamental frequency	Field strength of fundamental (millivolts/meter)	Field strength of harmonics (microvolts/meter)
902–928 MHz	50	500
2400–2483.5 MHz	50	500
5725–5875 MHz	50	500
24.0–24.25 GHz	250	2500

(d) Emissions radiated outside of the specified frequency bands, except for harmonics, shall be attenuated by at least 50 dB below the level of the fundamental or to the general radiated emission limits in § 15.209, whichever is the lesser attenuation.

Frequency (MHz)	Field strength (microvolts/meter)	Measurement distance (meters)
0.009–0.490	2400/F(kHz)	300
0.490–1.705	24000/F(kHz)	30
1.705–30.0	30	30
30–88	100 **	3
88–216	150 **	3
216–960	200 **	3
Above 960	500	3

** Except as provided in paragraph (g), fundamental emissions from intentional radiators operating under this section shall not be located in the frequency bands 54–72 MHz, 76–88 MHz, 174–216 MHz or 470–806 MHz. However, operation within these frequency bands is permitted under other sections of this part, e.g., §§15.231 and 15.241.

RESULTS

8.2.1. FUNDAMENTAL FREQUENCY RADIATED EMISSION

Frequency (GHz)	Meter Reading (dBuV)	Det	AF T345 (dB/m)	Amp/Cbl/Filtr/ Pad (dB)	Corrected Reading (dBuV/m)	Avg Limit (dBuV/m)	Margin (dB)	Peak Limit (dBuV/m)	PK Margin (dB)	Azimuth (Degs)	Height (cm)	Polarity
2.402	78.97	PK2	32.2	-22.4	88.77	-	-	114	-25.23	79	368	H
2.402	76.37	MAv1	32.2	-22.4	86.17	94	-7.83	-	-	79	368	H
2.402	75.9	PK2	32.2	-22.4	85.7	-	-	114	-28.3	199	152	V
2.402	72.74	MAv1	32.2	-22.4	82.54	94	-11.46	-	-	199	152	V
2.442	79.58	PK2	32.2	-22.3	89.48	-	-	114	-24.52	196	139	H
2.442	76.57	MAv1	32.2	-22.3	86.47	94	-7.53	-	-	196	139	H
2.442	75.99	PK2	32.2	-22.3	85.89	-	-	114	-28.11	28	122	V
2.442	72.77	MAv1	32.2	-22.3	82.67	94	-11.33	-	-	28	122	V
2.48	80.78	PK2	32.3	-22.2	90.88	-	-	114	-23.12	145	137	H
2.48	77.9	MAv1	32.3	-22.3	87.9	94	-6.1	-	-	145	137	H
2.48	76.27	PK2	32.3	-22.3	86.27	-	-	114	-27.73	127	200	V
2.48	73.48	MAv1	32.3	-22.3	83.48	94	-10.52	-	-	127	200	V

8.2.2. TRANSMITTER RESTRICTED BAND EDGES

RESTRICTED BANDEGE (LOW CHANNEL, HORIZONTAL)

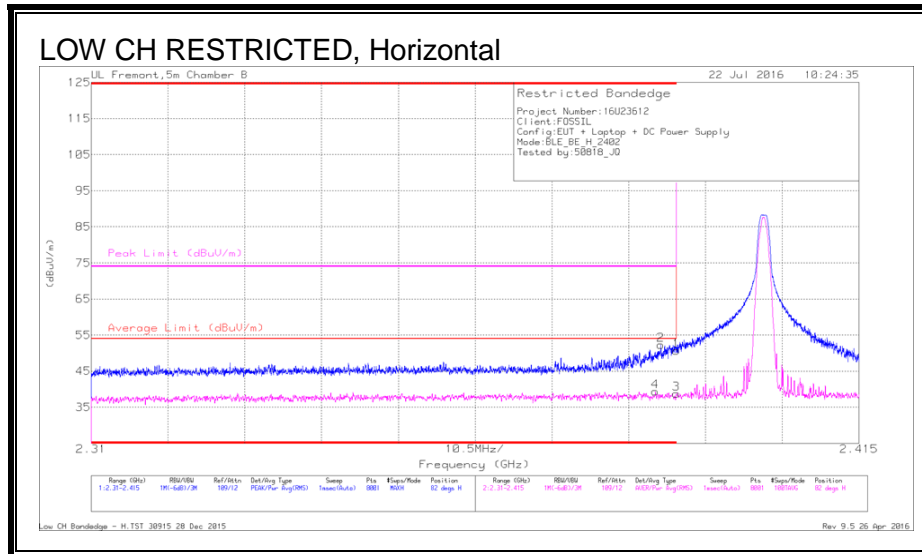

Trace Markers

Marker	Frequency (GHz)	Meter Reading (dBuV)	Det	AF T345 (dB/m)	Amp/Cbl/Ftr/Pad (dB)	Corrected Reading (dBuV/m)	Average Limit (dBuV/m)	Margin (dB)	Peak Limit (dBuV/m)	PK Margin (dB)	Azimuth (Degs)	Height (cm)	Polarity
1	* 2.39	40.92	Pk	32.1	-22.3	50.72	-	-	74	-23.28	82	321	H
2	* 2.388	42.63	Pk	32.1	-22.4	52.33	-	-	74	-21.67	82	321	H
3	* 2.39	26.84	RMS	32.1	-22.3	36.64	54	-17.36	-	-	82	321	H
4	* 2.387	27.64	RMS	32.1	-22.4	37.34	54	-16.66	-	-	82	321	H

* - indicates frequency in CFR15.205/IC8.10 RSS-Restricted Band

Pk - Peak detector

RMS - RMS detection

RESTRICTED BANDEDGE (LOW CHANNEL, VERTICAL)

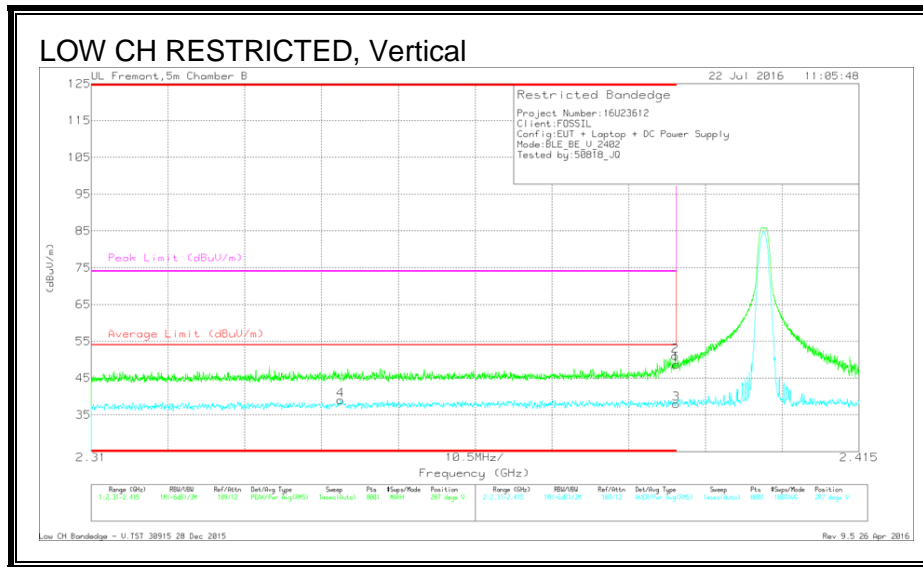

Trace Markers

Marker	Frequency (GHz)	Meter Reading (dBuV)	Det	AF T345 (dBm)	Amp/Chl/Filt/Pad (dB)	Corrected Reading (dBuV/m)	Average Limit (dBuV/m)	Margin (dB)	Peak Limit (dBuV/m)	PK Margin (dB)	Azimuth (Degs)	Height (cm)	Polarity
1	* 2.39	38.83	Pk	32.1	-22.3	48.63	-	-	74	-25.37	287	246	V
2	* 2.39	41.19	Pk	32.1	-22.3	50.99	-	-	74	-23.01	287	246	V
3	* 2.39	26.13	RMS	32.1	-22.3	35.93	54	-18.07	-	-	287	246	V
4	* 2.344	27.57	RMS	31.8	-22.4	36.97	54	-17.03	-	-	287	246	V

* - indicates frequency in CFR15.205/IC8.10 RSS-Restricted Band

Pk - Peak detector

RMS - RMS detection

RESTRICTED BANDEDGE (HIGH CHANNEL, HORIZONTAL)

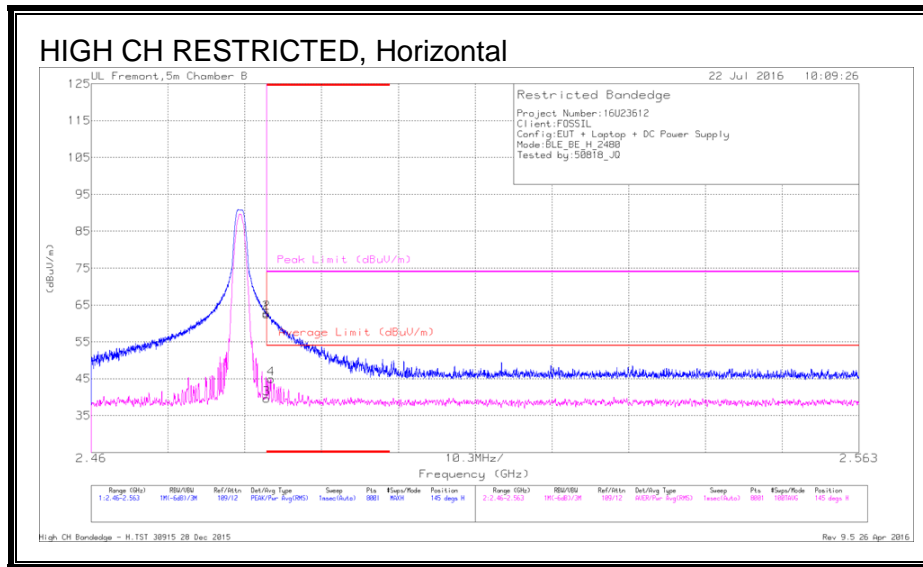

Trace Markers

Marker	Frequency (GHz)	Meter Reading (dBuV)	Det	AF T345 (dB/m)	Amp/Cbl/Ftr/Pad (dB)	Corrected Reading (dBuV/m)	Average Limit (dBuV/m)	Margin (dB)	Peak Limit (dBuV/m)	PK Margin (dB)	Azimuth (Degs)	Height (cm)	Polarity
1	* 2.484	52.52	Pk	32.3	-22.3	62.52	-	-	74	-11.48	145	137	H
2	* 2.484	52.8	Pk	32.3	-22.3	62.8	-	-	74	-11.2	145	137	H
3	* 2.484	27.59	RMS	32.3	-22.3	37.59	54	-16.41	-	-	145	137	H
4	* 2.484	32.85	RMS	32.3	-22.3	42.85	54	-11.15	-	-	145	137	H

* - indicates frequency in CFR15.205/IC8.10 RSS-Restricted Band

Pk - Peak detector

RMS - RMS detection

RESTRICTED BANDEDGE (HIGH CHANNEL, VERTICAL)

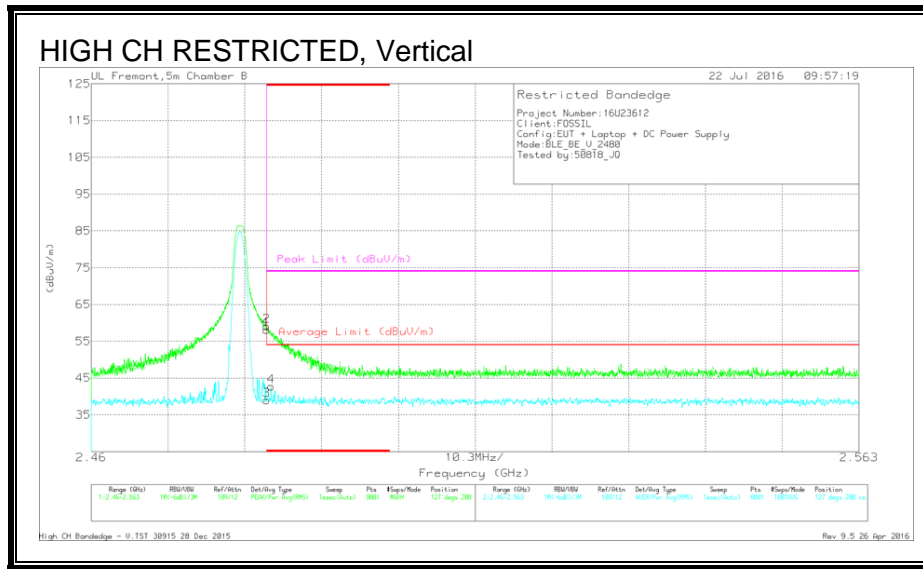

Trace Markers

Marker	Frequency (GHz)	Meter Reading (dBuV)	Det	AF T345 (dBm)	Amp/Ch/Filt/Pad (dB)	Corrected Reading (dBuV/m)	Average Limit (dBuV/m)	Margin (dB)	Peak Limit (dBuV/m)	PK Margin (dB)	Azimuth (Degs)	Height (cm)	Polarity
1	* 2.484	48.13	Pk	32.3	-22.3	58.13	-	-	74	-15.87	127	200	V
2	* 2.484	49.07	Pk	32.3	-22.3	59.07	-	-	74	-14.93	127	200	V
3	* 2.484	26.95	RMS	32.3	-22.3	36.95	54	-17.05	-	-	127	200	V
4	* 2.484	30.61	RMS	32.3	-22.3	40.61	54	-13.39	-	-	127	200	V

* - indicates frequency in CFR15.205/IC8.10 RSS-Restricted Band

Pk - Peak detector

RMS - RMS detection

8.2.3. HARMONICS AND SPURIOUS EMISSIONS ABOVE 1GHz

Low Channel Result

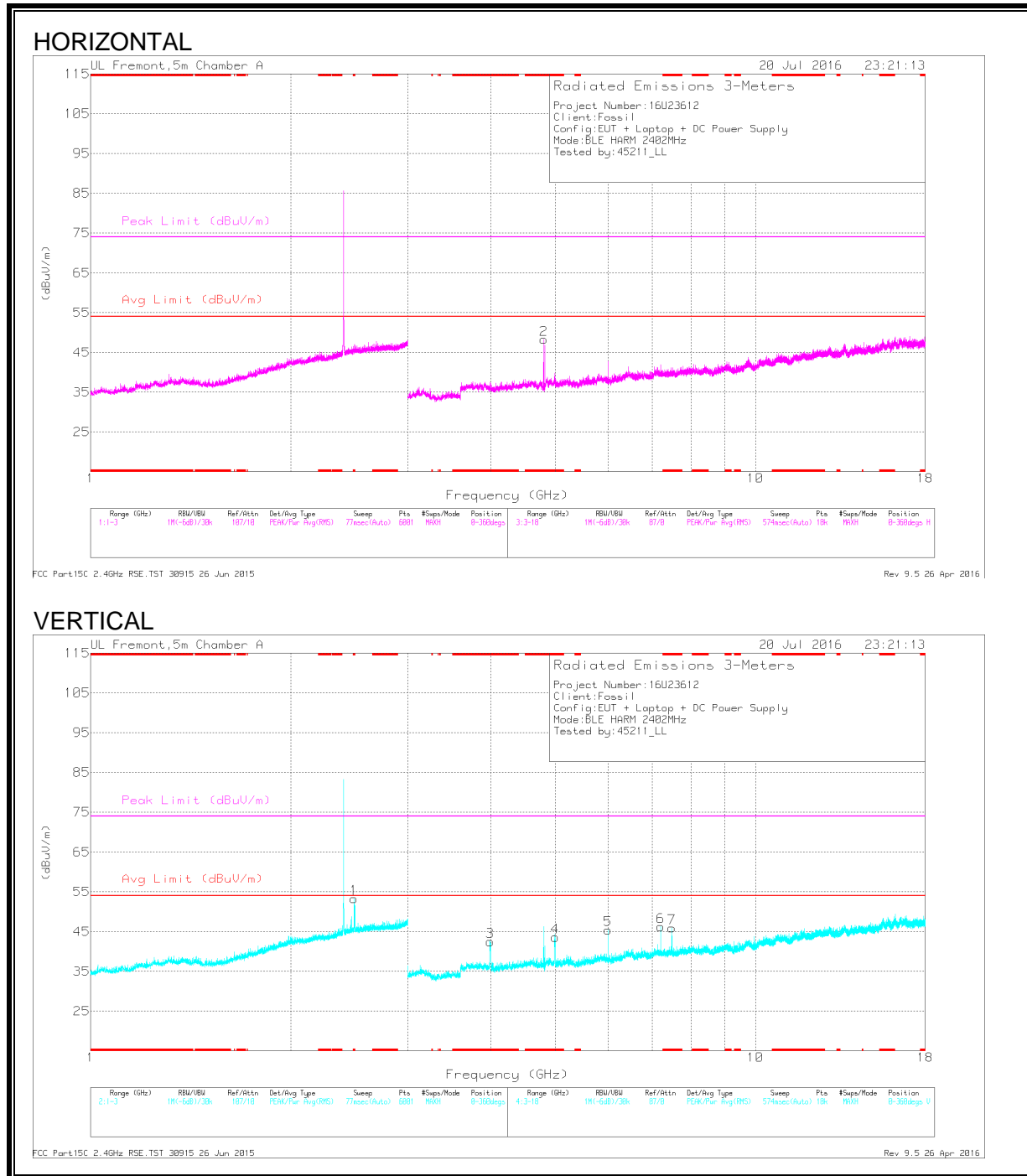

Trace Markers

Marker	Frequency (GHz)	Meter Reading (dBuV)	Det	AF T346 (db/m)	Amp/Ch/Fltr (dB)	DC Corr (dB)	Corrected Reading (dBuV/m)	Avg Limit (dBuV/m)	Margin (dB)	Peak Limit (dBuV/m)	PK Margin (dB)	Azimuth (Degs)	Height (cm)	Polarity
1	* 2.492	38.7	Pk	32.5	-17.9	0	53.3	-	-	74	-20.7	0-360	101	V
3	* 3.991	39.38	Pk	33.4	-30.3	0	42.48	-	-	74	-31.52	0-360	101	V
2	* 4.804	42.85	Pk	34.3	-28.9	0	48.25	-	-	74	-25.75	0-360	101	H
4	* 5	38.8	Pk	34.3	-29.5	0	43.6	-	-	74	-30.4	0-360	101	V
7	* 7.486	33.83	Pk	35.8	-23.7	0	45.93	-	-	74	-28.07	0-360	199	V
5	6	37.86	Pk	35.2	-27.6	0	45.46	-	-	-	-	0-360	199	V
6	7.206	35.14	Pk	35.7	-24.6	0	46.24	-	-	-	-	0-360	101	V

* - indicates frequency in CFR15.205/IC8.10 RSS-Restricted Band
 Pk - Peak detector

Radiated Emissions

Frequency (GHz)	Meter Reading (dBuV)	Det	AF T346 (db/m)	Amp/Ch/Fltr (dB)	Corrected Reading (dBuV/m)	Avg Limit (dBuV/m)	Margin (dB)	Peak Limit (dBuV/m)	PK Margin (dB)	Azimuth (Degs)	Height (cm)	Polarity
* 2.495	45.58	PK2	32.5	-17.9	60.18	-	-	74	-13.82	258	126	V
* 2.492	26.68	MAV1	32.5	-17.9	41.28	54	-12.72	-	-	258	126	V
* 3.994	45.82	PK2	33.4	-30.3	48.92	-	-	74	-25.08	257	101	V
* 3.993	33.48	MAV1	33.4	-30.3	36.58	54	-17.42	-	-	257	101	V
* 4.804	46.66	PK2	34.3	-28.9	52.06	-	-	74	-21.94	38	103	H
* 4.804	39.9	MAV1	34.3	-28.9	45.3	54	-8.7	-	-	38	103	H
* 5	49.41	PK2	34.3	-29.5	54.21	-	-	74	-19.79	280	102	V
* 5	33.61	MAV1	34.3	-29.5	38.41	54	-15.59	-	-	280	102	V
* 7.485	46.12	PK2	35.8	-23.7	58.22	-	-	74	-15.78	217	145	V
* 7.483	25.24	MAV1	35.8	-23.7	37.34	54	-16.66	-	-	217	145	V
6	46.99	PK2	35.2	-27.6	54.59	-	-	-	-	238	124	V
7.207	43.48	PK2	35.7	-24.6	54.58	-	-	-	-	124	288	V

* - indicates frequency in CFR15.205/IC8.10 RSS-Restricted Band
 Pk - Peak detector
 PK2 - KDB558074 Method: Maximum Peak
 MAV1 - KDB558074 Option 1 Maximum RMS Average

Middle Channel Result

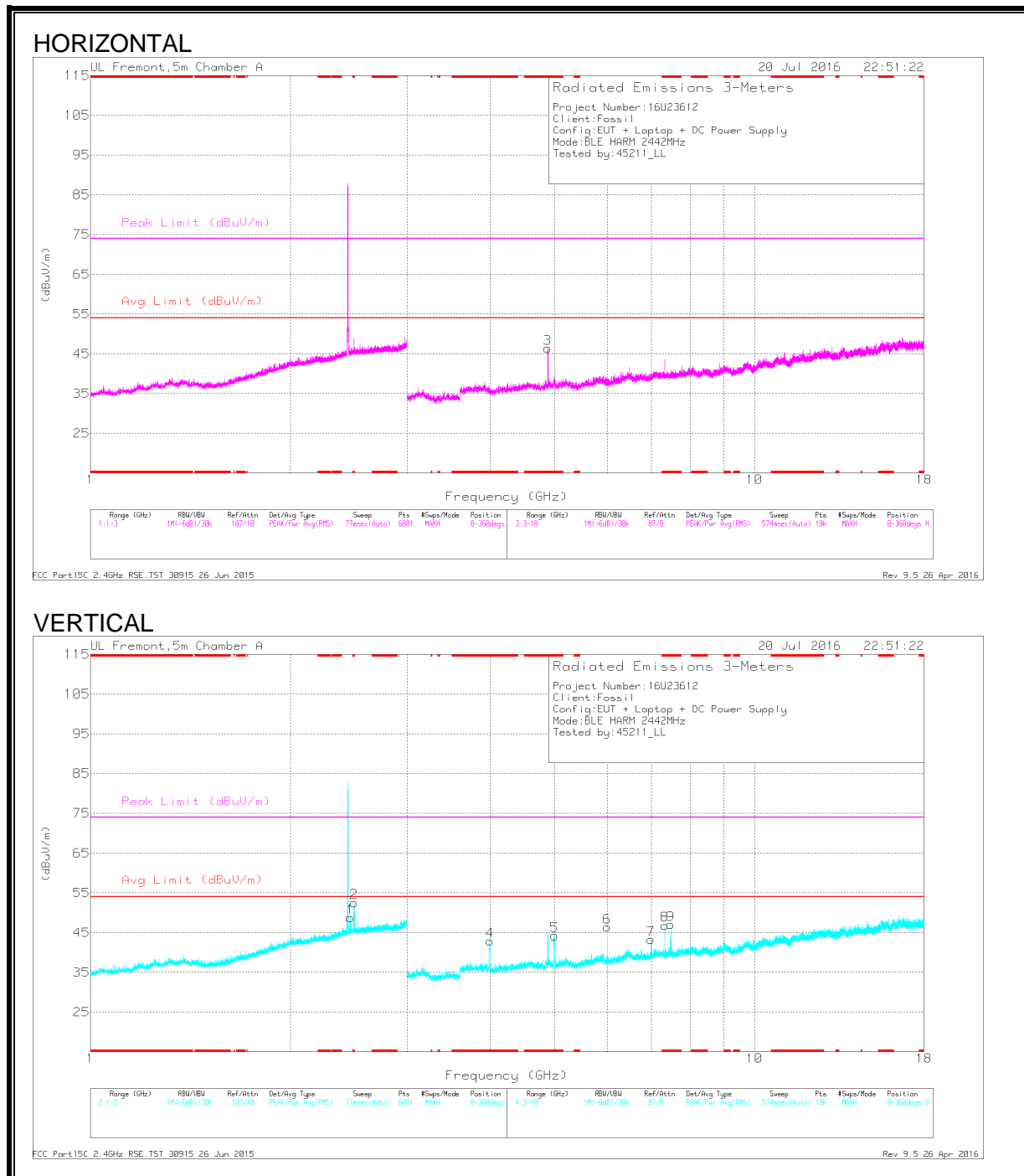

Trace Markers

Marker	Frequency (GHz)	Meter Reading (dBuV)	Det	AF T346 (db/m)	Amp/Cbl/Ftr (dB)	DC Corr (dB)	Corrected Reading (dBuV/m)	Avg Limit (dBuV/m)	Margin (dB)	Peak Limit (dBuV/m)	PK Margin (dB)	Azimuth (Degs)	Height (cm)	Polarity
2	* 2.495	37.94	Pk	32.5	-17.9	0	52.54	-	-	74	-21.46	0-360	199	V
1	2.463	34.38	Pk	32.4	-18	0	48.78	-	-	-	-	0-360	199	V
4	* 4	39.77	Pk	33.4	-30.3	0	42.87	-	-	74	-31.13	0-360	101	V
3	* 4.884	40.29	Pk	34.3	-28.2	0	46.39	-	-	74	-27.61	0-360	101	H
5	* 5	39.44	Pk	34.3	-29.5	0	44.24	-	-	74	-29.76	0-360	101	V
8	* 7.326	36.14	Pk	35.7	-25	0	46.84	-	-	74	-27.16	0-360	101	V
9	* 7.481	34.9	Pk	35.8	-23.7	0	47	-	-	74	-27	0-360	199	V
6	6	38.78	Pk	35.2	-27.6	0	46.38	-	-	-	-	0-360	199	V
7	6.984	32.99	Pk	35.7	-25.4	0	43.29	-	-	-	-	0-360	199	V

* - indicates frequency in CFR15.205/IC8.10 RSS-Restricted Band
 Pk - Peak detector

Radiated Emissions

Frequency (GHz)	Meter Reading (dBuV)	Det	AF T346 (db/m)	Amp/Cbl/Ftr (dB)	Corrected Reading (dBuV/m)	Avg Limit (dBuV/m)	Margin (dB)	Peak Limit (dBuV/m)	PK Margin (dB)	Azimuth (Degs)	Height (cm)	Polarity
* 2.493	45.08	PK2	32.5	-17.9	59.68	-	-	74	-14.32	282	305	V
* 2.493	26.43	MAv1	32.5	-17.9	41.03	54	-12.97	-	-	282	305	V
* 3.996	46.14	PK2	33.4	-30.3	49.24	-	-	74	-24.76	335	113	V
* 4	33.56	MAv1	33.4	-30.3	36.66	54	-17.34	-	-	335	113	V
* 4.884	44.6	PK2	34.3	-28.2	50.7	-	-	74	-23.3	42	114	H
* 4.884	37.19	MAv1	34.3	-28.2	43.29	54	-10.71	-	-	42	114	H
* 5	46.5	PK2	34.3	-29.5	51.3	-	-	74	-22.7	218	106	V
* 5	32.36	MAv1	34.3	-29.5	37.16	54	-16.84	-	-	218	106	V
* 7.325	40.61	PK2	35.7	-25	51.31	-	-	74	-22.69	352	116	V
* 7.325	31.99	MAv1	35.7	-25	42.69	54	-11.31	-	-	352	116	V
* 7.484	45.53	PK2	35.8	-23.7	57.63	-	-	74	-16.37	209	166	V
* 7.481	24.58	MAv1	35.8	-23.7	36.68	54	-17.32	-	-	209	166	V
2.463	41.54	PK2	32.4	-18	55.94	-	-	-	-	95	118	V
6	48.16	PK2	35.2	-27.6	55.76	-	-	-	-	63	135	V
6.984	35.3	PK2	35.7	-25.4	45.6	-	-	-	-	227	116	V

* - indicates frequency in CFR15.205/IC8.10 RSS-Restricted Band
 Pk - Peak detector
 PK2 - KDB558074 Method: Maximum Peak
 MAv1 - KDB558074 Option 1 Maximum RMS Average

High Channel Result

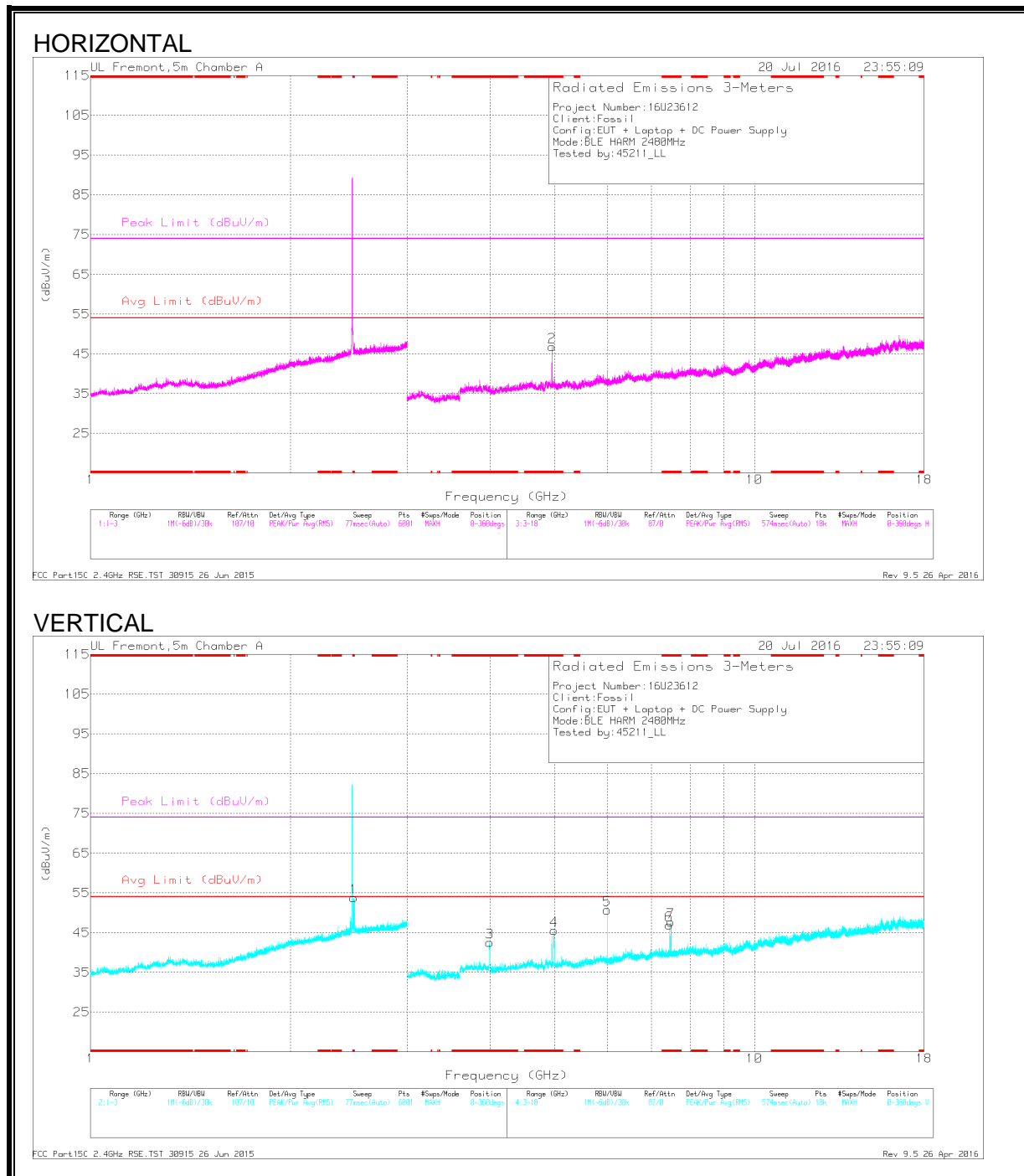

Trace Markers

Marker	Frequency (GHz)	Meter Reading (dBuV)	Det	AF T346 (db/m)	Amp/Ch/Filt (dB)	DC Corr (dB)	Corrected Reading (dBuV/m)	Avg Limit (dBuV/m)	Margin (dB)	Peak Limit (dBuV/m)	PK Margin (dB)	Azimuth (Degs)	Height (cm)	Polarity
1	* 2.492	39.23	Pk	32.5	-17.9	0	53.83	-	-	74	-20.17	0-360	101	V
3	* 3.994	39.49	Pk	33.4	-30.3	0	42.59	-	-	74	-31.41	0-360	101	V
2	* 4.96	41.42	Pk	34.3	-28.9	0	46.82	-	-	74	-27.18	0-360	199	H
4	* 4.992	40.64	Pk	34.3	-29.4	0	45.54	-	-	74	-28.46	0-360	101	V
6	* 7.44	34.74	Pk	35.8	-23.6	0	46.94	-	-	74	-27.06	0-360	101	V
7	* 7.476	35.57	Pk	35.8	-23.7	0	47.67	-	-	74	-26.33	0-360	199	V
5	6	43.13	Pk	35.2	-27.6	0	50.73	-	-	-	-	0-360	199	V

* - indicates frequency in CFR15.205/IC8.10 RSS-Restricted Band
 Pk - Peak detector

Radiated Emissions

Frequency (GHz)	Meter Reading (dBuV)	Det	AF T346 (db/m)	Amp/Ch/Filt (dB)	Corrected Reading (dBuV/m)	Avg Limit (dBuV/m)	Margin (dB)	Peak Limit (dBuV/m)	PK Margin (dB)	Azimuth (Degs)	Height (cm)	Polarity
* 2.495	47.12	PK2	32.5	-17.9	61.72	-	-	74	-12.28	273	196	V
* 2.494	27.76	MAV1	32.5	-17.9	42.36	54	-11.64	-	-	273	196	V
* 3.994	46.25	PK2	33.4	-30.3	49.35	-	-	74	-24.65	332	108	V
* 3.993	33.49	MAV1	33.4	-30.3	36.59	54	-17.41	-	-	332	108	V
* 4.96	43.71	PK2	34.3	-28.9	49.11	-	-	74	-24.89	298	286	H
* 4.96	35.76	MAV1	34.3	-28.9	41.16	54	-12.84	-	-	298	286	H
* 4.993	48.82	PK2	34.3	-29.4	53.72	-	-	74	-20.28	277	109	V
* 4.99	33.06	MAV1	34.3	-29.4	37.96	54	-16.04	-	-	277	109	V
* 7.439	39.04	PK2	35.8	-23.6	51.24	-	-	74	-22.76	357	101	V
* 7.439	31.11	MAV1	35.8	-23.6	43.31	54	-10.69	-	-	357	101	V
* 7.475	34.39	PK2	35.8	-23.7	46.49	-	-	74	-27.51	254	226	V
* 7.477	24.04	MAV1	35.8	-23.7	36.14	54	-17.86	-	-	254	226	V
6	39.42	PK2	35.2	-27.6	47.02	-	-	-	-	319	400	V

* - indicates frequency in CFR15.205/IC8.10 RSS-Restricted Band
 Pk - Peak detector
 PK2 - KDB558074 Method: Maximum Peak
 MAV1 - KDB558074 Option 1 Maximum RMS Average

8.2.1. WORST-CASE BELOW 30 MHz

SPURIOUS EMISSIONS BELOW 30 MHz

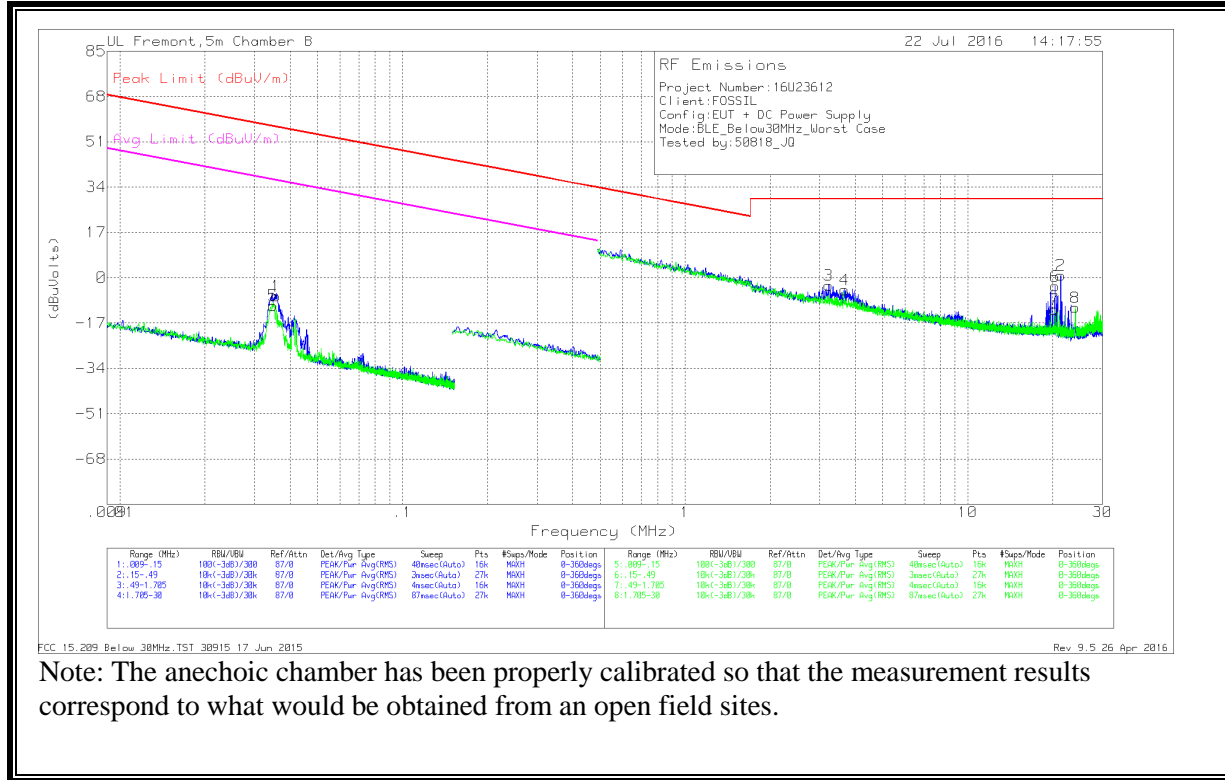

Note: The anechoic chamber has been properly calibrated so that the measurement results correspond to what would be obtained from an open field sites.

Trace Markers

Marker	Frequency (MHz)	Meter Reading (dBuV)	Det	Loop Antenna (dB/m)	Cbl (dB)	Dist Corr 300m	Corrected Reading (dBuVolts)	Peak Limit (dBuV/m)	Margin (dB)	Avg Limit (dBuV/m)	Margin (dB)	Azimuth (Degs)
5	.03481	55.59	Pk	12.6	1.4	-80	-10.41	56.77	-67.18	36.77	-47.18	0-360
1	.03564	59.25	Pk	12.5	1.4	-80	-6.85	56.57	-63.42	36.57	-43.42	0-360

Pk - Peak detector

Marker	Frequency (MHz)	Meter Reading (dBuV)	Det	Loop Antenna (dB/m)	Cbl (dB)	Dist Corr 30m	Corrected Reading (dBuVolts)	Peak Limit (dBuV/m)	Margin (dB)	Avg Limit (dBuV/m)	Margin (dB)	Azimuth (Degs)
3	3.2225	24.89	Pk	10.8	1.5	-40	-2.81	29.54	-32.35	-	-	0-360
4	3.66581	23.03	Pk	10.9	1.5	-40	-4.57	29.54	-34.11	-	-	0-360
7	20.3091	16.38	Pk	10	1.7	-40	-11.92	29.54	-41.46	-	-	0-360
6	20.34892	25.13	Pk	10	1.7	-40	-3.17	29.54	-32.71	-	-	0-360
2	21.32932	29.32	Pk	9.9	1.7	-40	.92	29.54	-28.62	-	-	0-360
8	24.03474	17.74	Pk	9.4	1.7	-40	-11.16	29.54	-40.7	-	-	0-360

Pk - Peak detector

8.2.2. WORST-CASE BELOW 1 GHz

SPURIOUS EMISSIONS 30 TO 1000 MHz

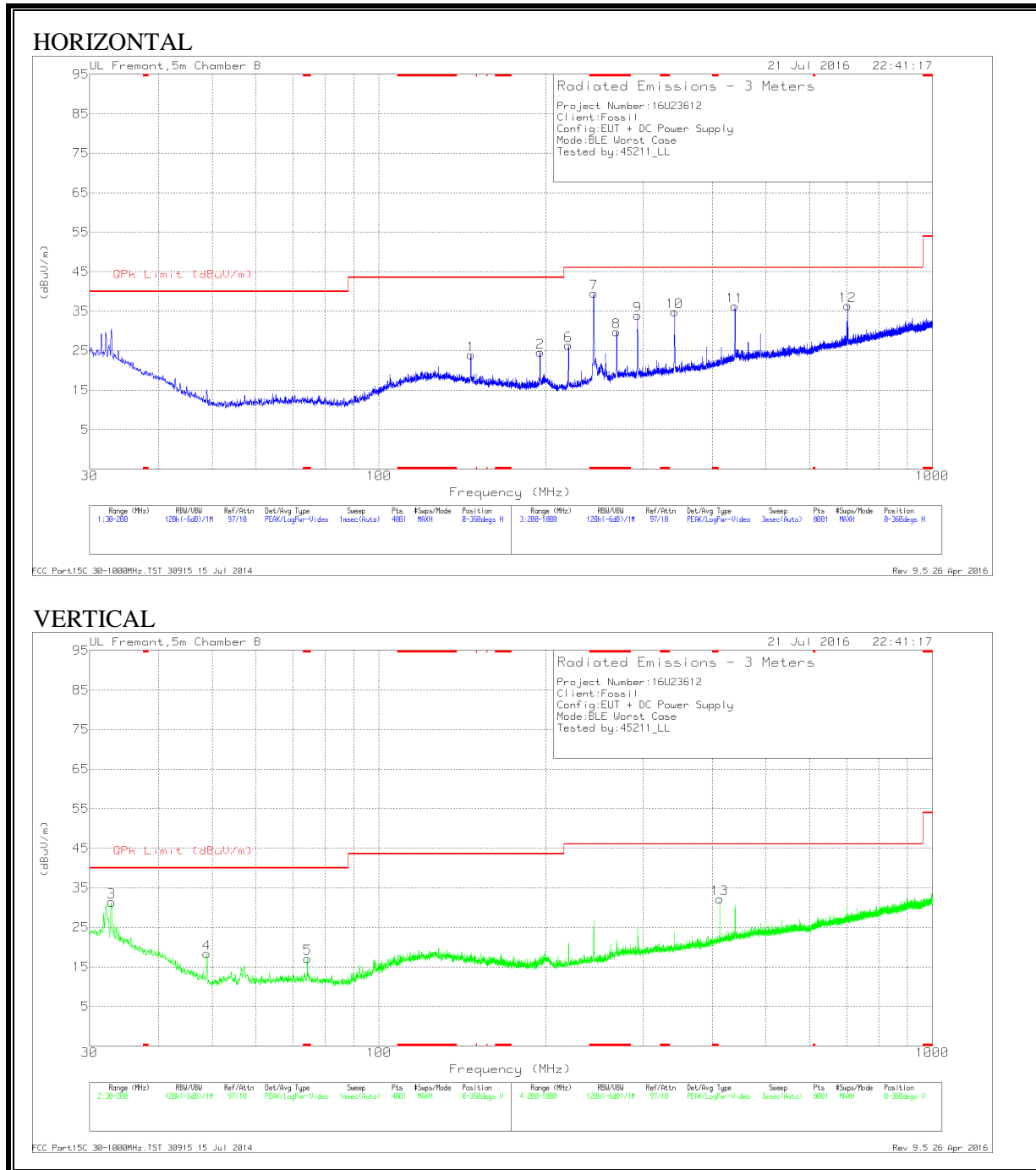

Trace Markers

Marker	Frequency (MHz)	Meter Reading (dBuV)	Det	AF T130 (dB/m)	Amp/Cbl (dB)	Corrected Reading (dBuV/m)	QPk Limit (dBuV/m)	Margin (dB)	Azimuth (Degs)	Height (cm)	Polarity
5	* 74.2425	33.56	Pk	11.9	-28.3	17.16	40	-22.84	0-360	100	V
7	* 244.4	50.65	Pk	15.5	-26.6	39.55	46.02	-6.47	0-360	100	H
8	* 268.8	39.23	Pk	17	-26.4	29.83	46.02	-16.19	0-360	100	H
3	32.8475	36.98	Pk	23.2	-28.8	31.38	40	-8.62	0-360	100	V
4	48.8275	34.99	Pk	12	-28.6	18.39	40	-21.61	0-360	100	V
1	146.5775	34.98	Pk	16.6	-27.6	23.98	43.52	-19.54	0-360	300	H
2	195.4525	35.93	Pk	15.8	-27.1	24.63	43.52	-18.89	0-360	200	H
6	219.9	38.5	Pk	14.7	-26.8	26.4	46.02	-19.62	0-360	200	H
9	293.2	42.99	Pk	17.2	-26.2	33.99	46.02	-12.03	0-360	100	H
10	342.2	42.95	Pk	18	-26.1	34.85	46.02	-11.17	0-360	100	H
13	412.7	38.43	Pk	20	-26.2	32.23	46.02	-13.79	0-360	300	V
11	439.7	41.91	Pk	20.6	-26.2	36.31	46.02	-9.71	0-360	100	H
12	703.1	37.51	Pk	24.2	-25.3	36.41	46.02	-9.61	0-360	200	H

Pk - Peak detector

8.2.3. WORST-CASE ABOVE 18 GHz

SPURIOUS EMISSIONS 18 TO 26 GHz

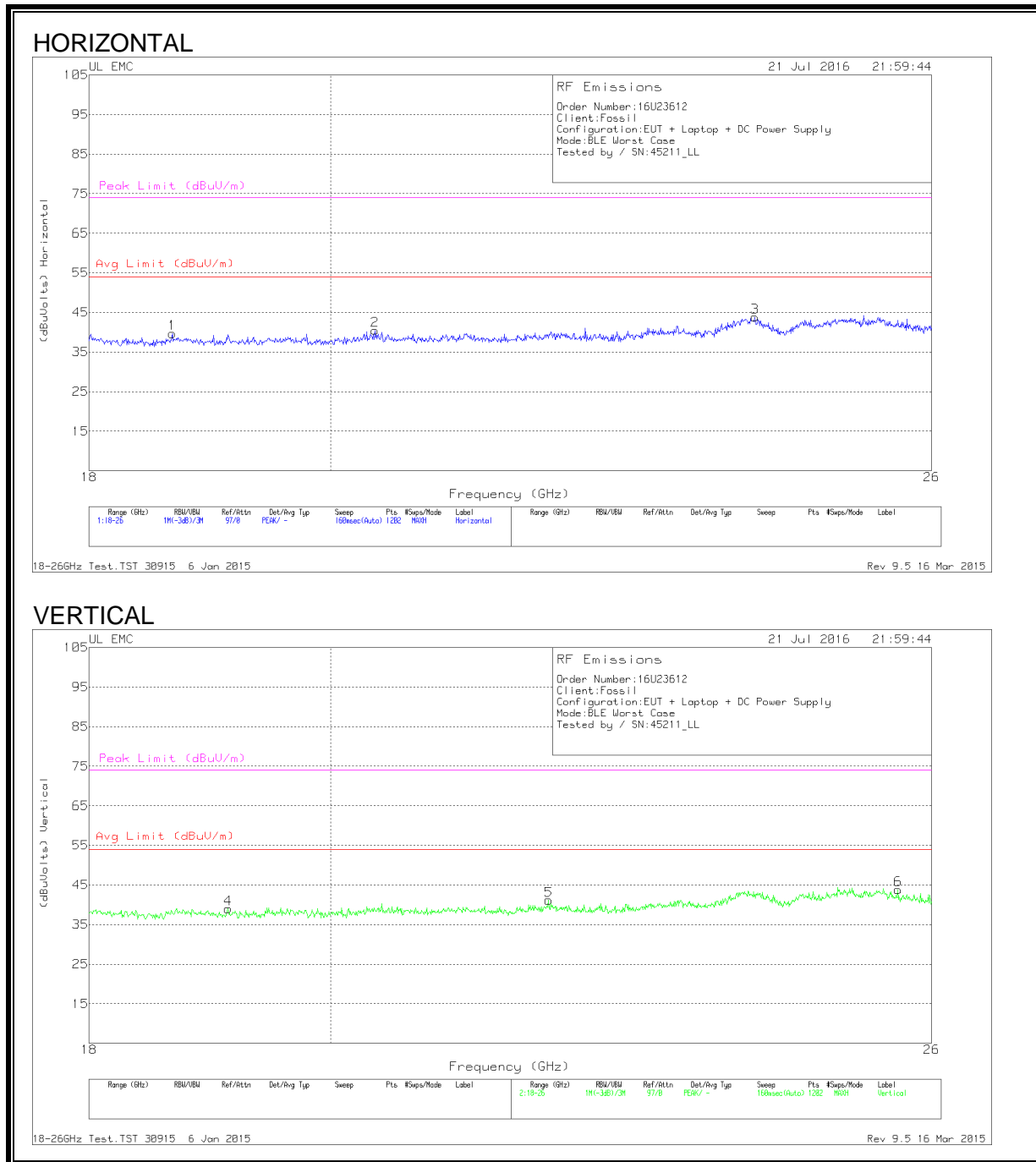

Trace Markers

Marker	Frequency (GHz)	Meter Reading (dBuV)	Det	AF T449 (dB/m)	Amp/Cbl (dB)	Dist Corr (dB)	Corrected Reading (dBuVolts)	Avg Limit (dBuV/m)	Margin (dB)	Peak Limit (dBuV/m)	PK Margin (dB)
1	18.666	41.47	Pk	32.5	-24.8	-9.5	39.67	54	-14.33	74	-34.33
2	20.391	42.2	Pk	32.9	-25.1	-9.5	40.5	54	-13.5	74	-33.5
3	24.068	43.83	Pk	34	-24.5	-9.5	43.83	54	-10.17	74	-30.17
4	19.126	40.2	Pk	32.7	-24.4	-9.5	39	54	-15	74	-35
5	21.997	42.37	Pk	33.5	-25.2	-9.5	41.17	54	-12.83	74	-32.83
6	25.62	43.73	Pk	34.3	-24.7	-9.5	43.83	54	-10.17	74	-30.17

Pk - Peak detector