

Variant FCC Test Report

Report No.: RF181221C17

FCC ID: UK7-DW9

Test Model: DW9B1

Received Date: Dec. 21, 2018

Test Date: Jan. 04, 2019

Issued Date: Jan. 09, 2019

Applicant: Fossil Group, Inc.

Address: 901 S. Central Expressway, Richardson, TX 75080, USA

Issued By: Bureau Veritas Consumer Products Services (H.K.) Ltd., Taoyuan Branch

Lab Address: No. 47-2, 14th Ling, Chia Pau Vil., Lin Kou Dist., New Taipei City, Taiwan
(R.O.C)

Test Location: B2F., No.215, Sec. 3, Beixin Rd., Xindian Dist., New Taipei City 231,
Taiwan, R.O.C

**FCC Registration /
Designation Number:** 427177 / TW0011



This report is for your exclusive use. Any copying or replication of this report to or for any other person or entity, or use of our name or trademark, is permitted only with our prior written permission. This report sets forth our findings solely with respect to the test samples identified herein. The results set forth in this report are not indicative or representative of the quality or characteristics of the lot from which a test sample was taken or any similar or identical product unless specifically and expressly noted. Our report includes all of the tests requested by you and the results thereof based upon the information that you provided to us. You have 60 days from date of issuance of this report to notify us of any material error or omission caused by our negligence, provided, however, that such notice shall be in writing and shall specifically address the issue you wish to raise. A failure to raise such issue within the prescribed time shall constitute your unqualified acceptance of the completeness of this report, the tests conducted and the correctness of the report contents. Unless specific mention, the uncertainty of measurement has been explicitly taken into account to declare the compliance or non-compliance to the specification. The report must not be used by the client to claim product certification, approval, or endorsement by TAF or any government agencies.

Table of Contents

Release Control Record	3
1 Certificate of Conformity	4
2 Summary of Test Results.....	5
2.1 Measurement Uncertainty.....	5
2.2 Modification Record	5
3 General Information	6
3.1 General Description of EUT	6
3.2 Description of Test Modes.....	7
3.2.1 Test Mode Applicability and Tested Channel Detail.....	8
3.3 Description of Support Units	9
3.3.1 Configuration of System under Test	9
3.4 General Description of Applied Standards.....	9
4 Test Types and Results	10
4.1 Radiated Emission and Bandedge Measurement	10
4.1.1 Limits of Radiated Emission and Bandedge Measurement	10
4.1.2 Test Instruments	11
4.1.3 Test Procedures.....	12
4.1.4 Deviation from Test Standard	13
4.1.5 Test Set Up	13
4.1.6 EUT Operating Conditions.....	14
4.1.7 Test Results	15
5 Pictures of Test Arrangements.....	47
Annex A- Band-edge measurement	48
Appendix – Information on the Testing Laboratories	51

Release Control Record

Issue No.	Description	Date Issued
RF181221C17	Original Release	Jan. 09, 2019

1 Certificate of Conformity

Product: Smart Watch

Test Model: DW9B1

Sample Status: Identical Prototype

Applicant: Fossil Group, Inc.

Test Date: Jan. 04, 2019

Standards: 47 CFR FCC Part 15, Subpart C (Section 15.247)
ANSI C63.10:2013

This report is issued as a supplementary report to BV CPS report no.: RF180621C33. This report shall be used by combining with its original report.

Prepared by :  , **Date:** Jan. 09, 2019
Gina Liu / Specialist

Approved by :  , **Date:** Jan. 09, 2019
Dylan Chiou / Project Engineer

2 Summary of Test Results

47 CFR FCC Part 15, Subpart C (Section 15.247)			
FCC Clause	Test Item	Result	Remarks
15.207	AC Power Conducted Emission	N/A	Refer to Note
15.205 / 15.209 / 15.247(d)	Radiated Emissions and Band Edge Measurement	Pass	Meet the requirement of limit. Minimum passing margin is -1.31 dB at 2483.52 MHz.
15.247(d)	Antenna Port Emission	N/A	Refer to Note
15.247(a)(2)	6 dB Bandwidth	N/A	Refer to Note
---	Occupied Bandwidth Measurement	N/A	Refer to Note
15.247(b)	Conducted power	N/A	Refer to Note
15.247(e)	Power Spectral Density	N/A	Refer to Note
15.203	Antenna Requirement	N/A	Refer to Note

Note: Only Radiated Emissions was performed for this report. Refer to original report for other test data.

2.1 Measurement Uncertainty

Where relevant, the following measurement uncertainty levels have been estimated for tests performed on the EUT:

The listed uncertainties are the worst case uncertainty for the entire range of measurement. Please note that the uncertainty values are provided for informational purposes only and are not used in determining the PASS/FAIL results.

Measurement	Frequency	Expanded Uncertainty (k=2) (±)
Radiated Emissions up to 1 GHz	30 MHz ~ 200 MHz	2.93 dB
	200 MHz ~1000 MHz	2.95 dB
Radiated Emissions above 1 GHz	1 GHz ~ 18 GHz	2.26 dB
	18 GHz ~ 40 GHz	1.94 dB

2.2 Modification Record

There were no modifications required for compliance.

3 General Information

3.1 General Description of EUT

Product	Smart Watch
Test Model	DW9B1
Status of EUT	Identical Prototype
Power Supply Rating	5 Vdc (adapter or host equipment) 3.85 Vdc (battery)
Modulation Type	CCK, DQPSK, DBPSK for DSSS 64QAM, 16QAM, QPSK, BPSK for OFDM
Modulation Technology	DSSS, OFDM
Transfer Rate	802.11b: 11.0 / 5.5 / 2.0 / 1.0 Mbps 802.11g: 54.0 / 48.0 / 36.0 / 24.0 / 18.0 / 12.0 / 9.0 / 6.0 Mbps 802.11n: up to 72.2 Mbps
Operating Frequency	2412 ~ 2472 MHz
Number of Channel	13 for 802.11b, 802.11g, 802.11n (HT20)
Antenna Type	Loop antenna
Antenna Connector	N/A
Accessory Device	Refer to Note as below
Data Cable Supplied	Refer to Note as below

Note:

1. This report is issued as a supplementary report to BV CPS report no. RF180621C33. The difference compared with original report is adding model (DW9B1) and new antenna. Therefore, only Radiated Emissions was verified and recorded in this report.
2. The model is listed as below.

Model	WLAN / BT Antenna Gain	GPS Antenna Gain
DW9B1	-5.88 dBi	-4.02 dBi

3. The EUT provide one completed transmitter and one receiver.

Modulation Mode	Tx Function
802.11b	1TX
802.11g	1TX
802.11n (HT20)	1TX

4. The EUT accessories list refer to user manual.
5. Confirmed output power has been verified as original filing before starting the C2PC testing.
6. The above EUT information is declared by manufacturer and for more detailed features description, please refer to the manufacturer's specifications or user's manual.

3.2 Description of Test Modes

13 channels are provided for 802.11b, 802.11g and 802.11n (HT20):

Channel	Frequency (MHz)	Channel	Frequency (MHz)
1	2412	8	2447
2	2417	9	2452
3	2422	10	2457
4	2427	11	2462
5	2432	12	2467
6	2437	13	2472
7	2442		

3.2.1 Test Mode Applicability and Tested Channel Detail

EUT Configure Mode	Applicable To				Description
	RE \geq 1G	RE<1G	PLC	APCM	
-	√	√	-	-	-

Where **RE \geq 1G**: Radiated Emission above 1 GHz **RE<1G**: Radiated Emission below 1 GHz
PLC: Power Line Conducted Emission **APCM**: Antenna Port Conducted Measurement

Note:

1. The EUT had been pre-tested on the positioned of each 3 axis. The worst case was found when positioned on **Y-plane**.
2. "-" means no effect.

Radiated Emission Test (Above 1 GHz):

- Pre-Scan has been conducted to determine the worst-case mode from all possible combinations between available modulations, data rates and antenna ports (if EUT with antenna diversity architecture).
- Following channel(s) was (were) selected for the final test as listed below.

EUT Configure Mode	Mode	Available Channel	Tested Channel	Modulation Technology	Modulation Type	Data Rate (Mbps)
-	802.11b	1 to 13	1, 6, 11, 12, 13	DSSS	DBPSK	1.0
-	802.11g	1 to 13	1, 6, 11, 12, 13	OFDM	BPSK	6.0
-	802.11n (HT20)	1 to 13	1, 6, 11, 12, 13	OFDM	BPSK	6.5

Radiated Emission Test (Below 1 GHz):

- Pre-Scan has been conducted to determine the worst-case mode from all possible combinations between available modulations, data rates and antenna ports (if EUT with antenna diversity architecture).
- Following channel(s) was (were) selected for the final test as listed below.

EUT Configure Mode	Mode	Available Channel	Tested Channel	Modulation Technology	Modulation Type	Data Rate (Mbps)
-	802.11n (HT20)	1 to 13	13	OFDM	BPSK	6.5

Test Condition:

Applicable To	Environmental Conditions	Input Power	Tested by
RE \geq 1G	25 deg. C, 65 % RH	120 Vac, 60 Hz	Charles Hsiao
RE<1G	25 deg. C, 65 % RH	120 Vac, 60 Hz	Karl Lee

3.3 Description of Support Units

The EUT has been tested as an independent unit together with other necessary accessories or support units. The following support units or accessories were used to form a representative test configuration during the tests.

No.	Product	Brand	Model No.	Serial No.	FCC ID
1.	Adapter	HTC	TC U250	N/A	N/A

No.	Signal Cable Description Of The Above Support Units
1.	N/A

Note:

1. All power cords of the above support units are non-shielded (1.8m).

3.3.1 Configuration of System under Test

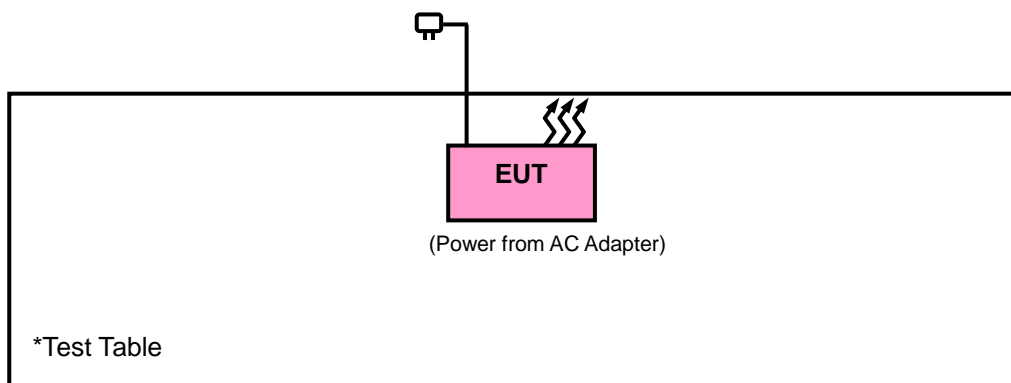

3.4 General Description of Applied Standards

The EUT is a RF Product. According to the specifications of the manufacturer, it must comply with the requirements of the following standards:

FCC Part 15, Subpart C (15.247)

558074 D01 15.247 Meas Guidance v05r01

ANSI C63.10-2013

All test items have been performed and recorded as per the above standards.

NOTE: The EUT has been verified to comply with the requirements of FCC Part 15, Subpart B, Class B (DoC). The test report has been issued separately.

4 Test Types and Results

4.1 Radiated Emission and Bandedge Measurement

4.1.1 Limits of Radiated Emission and Bandedge Measurement

Radiated emissions which fall in the restricted bands must comply with the radiated emission limits specified as below table. Other emissions shall be at least 20 dB below the highest level of the desired power:

Frequencies (MHz)	Field Strength (microvolts/meter)	Measurement Distance (meters)
0.009 ~ 0.490	2400/F (kHz)	300
0.490 ~ 1.705	24000/F (kHz)	30
1.705 ~ 30.0	30	30
30 ~ 88	100	3
88 ~ 216	150	3
216 ~ 960	200	3
Above 960	500	3

NOTE:

1. The lower limit shall apply at the transition frequencies.
2. Emission level (dBuV/m) = 20 log Emission level (uV/m).
3. For frequencies above 1000 MHz, the field strength limits are based on average detector, however, the peak field strength of any emission shall not exceed the maximum permitted average limits, specified above by more than 20 dB under any condition of modulation.

4.1.2 Test Instruments

Description & Manufacturer	Model No.	Serial No.	Date of Calibration	Due Date of Calibration
Test Receiver Agilent Technologies	N9038A	MY51210203	Mar. 16, 2018	Mar. 15, 2019
Spectrum Analyzer ROHDE & SCHWARZ	FSU43	101261	Jan. 11, 2018	Jan. 10, 2019
BILOG Antenna SCHWARZBECK	VULB9168	9168-616	Nov. 27, 2018	Nov. 26, 2019
HORN Antenna ETS-Lindgren	3117	00143293	Nov. 25, 2018	Nov. 24, 2019
HORN Antenna Schwarzbeck	BBHA 9170	9170-480	Nov. 25, 2018	Nov. 24, 2019
Loop Antenna	EM-6879	269	Sep. 07, 2018	Sep. 06, 2019
Preamplifier Agilent	310N	187226	Jun. 19, 2018	Jun. 18, 2019
Preamplifier Agilent	83017A	MY39501357	Jun. 19, 2018	Jun. 18, 2019
RF signal cable ETS-LINDGREN	5D-FB	Cable-CH1-01(RFC -SMS-100-SMS-12 0+RFC-SMS-100-S MS-400)	Jun. 19, 2018	Jun. 18, 2019
RF signal cable ETS-LINDGREN	8D-FB	Cable-CH1-02(RFC -SMS-100-SMS-24)	Jun. 19, 2018	Jun. 18, 2019
Software	E3 8.130425b	NA	NA	NA
Antenna Tower MF	NA	NA	NA	NA
Turn Table MF	NA	NA	NA	NA
Antenna Tower & Turn Table Controller MF	MF-7802	NA	NA	NA

- Note: 1. The calibration interval of the above test instruments is 12 months and the calibrations are traceable to NML/ROC and NIST/USA.
2. The test was performed in HsinTien Chamber 1.
3. The horn antenna and preamplifier (model: 83017A) are used only for the measurement of emission frequency above 1 GHz if tested.
4. The IC Site Registration No. is IC7450I-1.

4.1.3 Test Procedures

For Radiated Emission below 30 MHz

- a. The EUT was placed on the top of a rotating table 0.8 meters above the ground at a 3 meter chamber room. The table was rotated 360 degrees to determine the position of the highest radiation.
- b. The EUT was set 3 meters away from the interference-receiving antenna, which was mounted on the top of a variable-height antenna tower.
- c. Parallel, perpendicular, and ground-parallel orientations of the antenna are set to make the measurement.
- d. For each suspected emission, the EUT was arranged to its worst case and the rotatable table was turned from 0 degrees to 360 degrees to find the maximum reading.
- e. The test-receiver system was set to Quasi-Peak Detect Function and Specified Bandwidth with Maximum Hold Mode.

Note:

1. The resolution bandwidth and video bandwidth of test receiver/spectrum analyzer is 9 kHz at frequency below 30 MHz.
2. There is a comparison data of both open-field test site and semi-Anechoic chamber, and the result came out very similar.

For Radiated Emission above 30 MHz

- a. The EUT was placed on the top of a rotating table 0.8 meters (for 30 MHz ~ 1 GHz) / 1.5 meters (for above 1 GHz) above the ground at 3 meter chamber room for test. The table was rotated 360 degrees to determine the position of the highest radiation.
- b. The EUT was set 3 meters away from the interference-receiving antenna, which was mounted on the top of a variable-height antenna tower.
- c. The height of antenna is varied from one meter to four meters above the ground to determine the maximum value of the field strength. Both horizontal and vertical polarizations of the antenna are set to make the measurement.
- d. For each suspected emission, the EUT was arranged to its worst case and then the antenna was tuned to heights from 1 meter to 4 meters and the rotatable table was turned from 0 degrees to 360 degrees to find the maximum reading.
- e. The test-receiver system was set to quasi-peak detect function and specified bandwidth with maximum hold mode when the test frequency is below 1 GHz.
- f. The test-receiver system was set to peak and average detected function and specified bandwidth with maximum hold mode when the test frequency is above 1 GHz. If the peak reading value also meets average limit, measurement with the average detector is unnecessary.

Note:

1. The resolution bandwidth and video bandwidth of test receiver/spectrum analyzer is 120 kHz for Quasi-peak detection (QP) or Peak detection (PK) at frequency below 1 GHz.
2. The resolution bandwidth of test receiver/spectrum analyzer is 1 MHz and the video bandwidth is 3 MHz for Peak detection (PK) at frequency above 1 GHz.
3. The resolution bandwidth of test receiver/spectrum analyzer is 1 MHz and the video bandwidth is $\geq 1/T$ (Duty cycle < 98 %) or 10 Hz (Duty cycle ≥ 98 %) for Average detection (AV) at frequency above 1 GHz.
(11b: RBW = 1 MHz, VBW = 300 Hz ; 11g: RBW = 1 MHz, VBW = 1 kHz ;
11n (HT20): RBW = 1 MHz, VBW = 1 kHz)
4. All modes of operation were investigated and the worst-case emissions are reported.

4.1.4 Deviation from Test Standard

No deviation.

4.1.5 Test Set Up

<Radiated emission below 30 MHz>

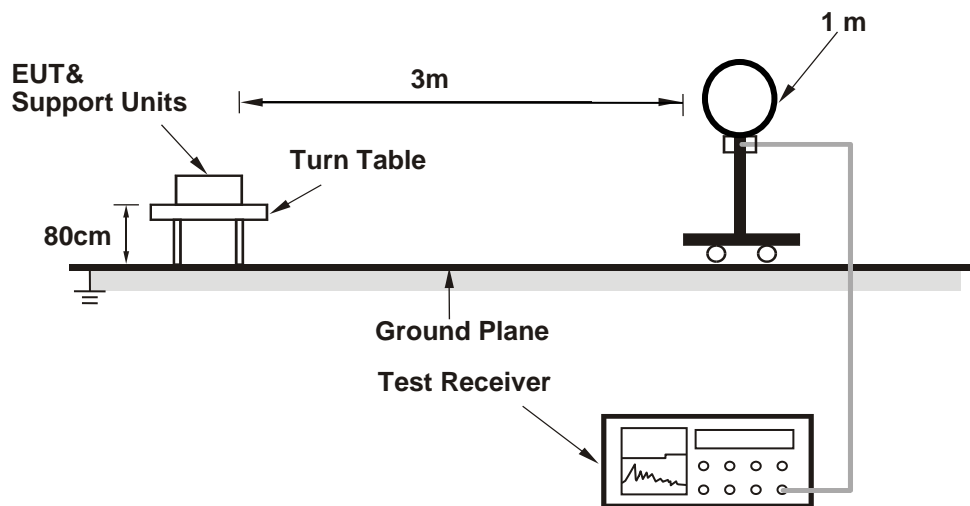

<Frequency Range below 1 GHz>

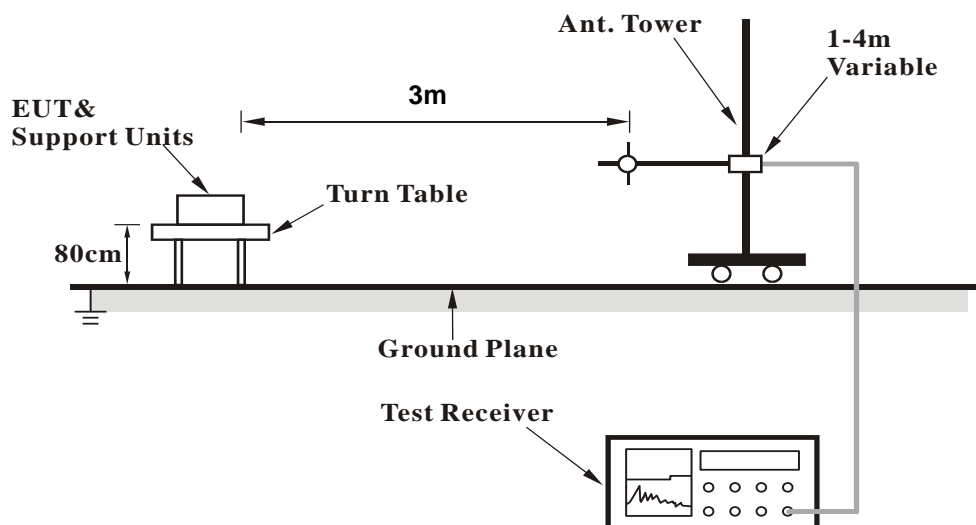

<Frequency Range above 1 GHz>

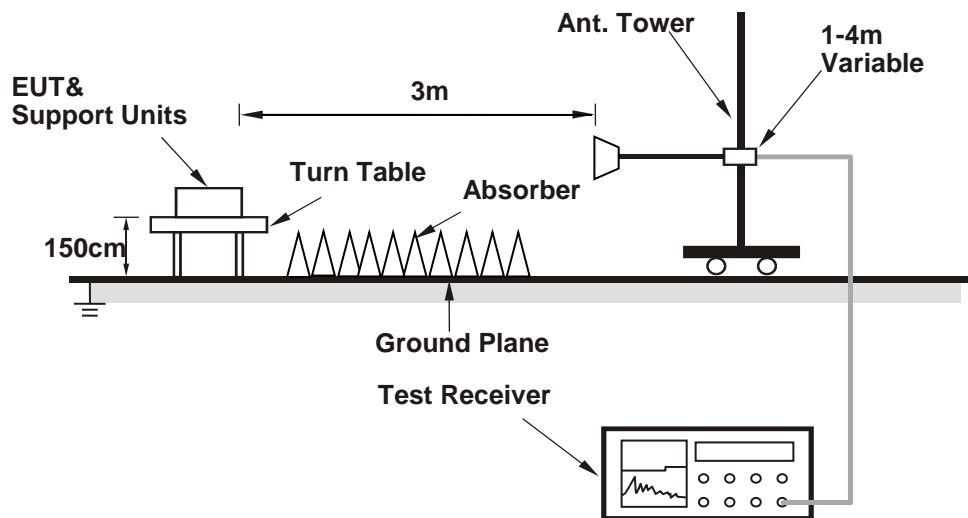

For the actual test configuration, please refer to the attached file (Test Setup Photo).

4.1.6 EUT Operating Conditions

- a. Placed the EUT on a testing table.
- b. Use the software to control the EUT under transmission condition continuously at specific channel frequency.

4.1.7 Test Results
ABOVE 1GHz DATA
802.11b

EUT Test Condition		Measurement Detail	
Channel	Channel 1	Frequency Range	1 GHz ~ 25 GHz
Input Power	120 Vac, 60 Hz	Detector Function	Peak (PK) Average (AV)
Environmental Conditions	25 deg. C, 65 % RH	Tested By	Charles Hsiao

Horizontal

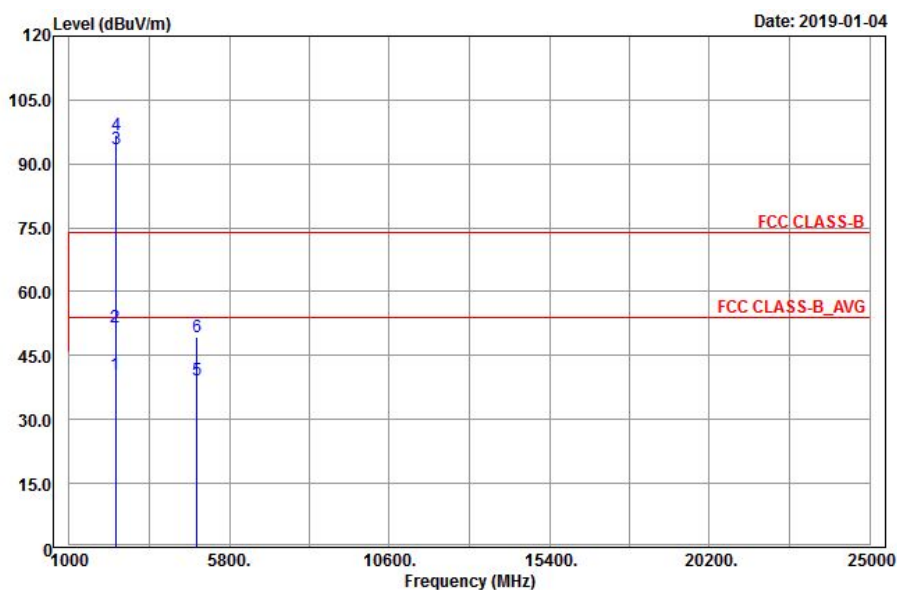

Vertical

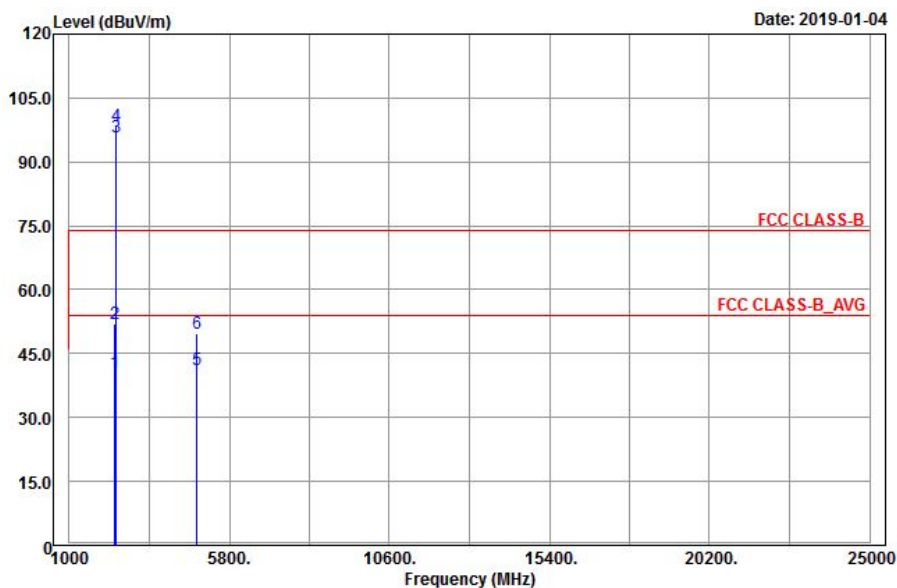

Antennal Polarity & Test Distance: Horizontal at 3 m										
Frequency (MHz)	Emission Level (dBuV/m)	Read Level (dBuV)	Limit (dBuV/m)	Margin (dB)	Antenna Factor (dB/m)	Cable Loss (dB)	Preamp Factor (dB)	Antenna Height (cm)	Table Angle (Degree)	Remark
2389.47	40.5	34.06	54	-13.5	31.8	5.4	30.76	100	8	Average
2389.47	51.66	45.22	74	-22.34	31.8	5.4	30.76	100	8	Peak
2412	93.64	87.13			31.81	5.43	30.73	100	8	Average
2412	96.7	90.19			31.81	5.43	30.73	100	8	Peak
4824	39.28	26.83	54	-14.72	33.97	8.26	29.78	122	165	Average
4824	49.27	36.82	74	-24.73	33.97	8.26	29.78	122	165	Peak
Antennal Polarity & Test Distance: Vertical at 3 m										
Frequency (MHz)	Emission Level (dBuV/m)	Read Level (dBuV)	Limit (dBuV/m)	Margin (dB)	Antenna Factor (dB/m)	Cable Loss (dB)	Preamp Factor (dB)	Antenna Height (cm)	Table Angle (Degree)	Remark
2374.8	40.5	34.11	54	-13.5	31.78	5.37	30.76	277	299	Average
2374.8	51.83	45.44	74	-22.17	31.78	5.37	30.76	277	299	Peak
2412	95.65	89.14			31.81	5.43	30.73	277	299	Average
2412	98.48	91.97			31.81	5.43	30.73	277	299	Peak
4824	41.28	28.83	54	-12.72	33.97	8.26	29.78	155	187	Average
4824	49.61	37.16	74	-24.39	33.97	8.26	29.78	155	187	Peak

Remarks:

- Emission Level = Read Level + Antenna Factor + Cable Loss - Preamp Factor
Margin value = Emission level – Limit value
- 2412 MHz: Fundamental frequency.
- The emission levels of other frequencies were very low against the limit.

EUT Test Condition		Measurement Detail	
Channel	Channel 6	Frequency Range	1 GHz ~ 25 GHz
Input Power	120 Vac, 60 Hz	Detector Function	Peak (PK) Average (AV)
Environmental Conditions	25 deg. C, 65 % RH	Tested By	Charles Hsiao

Horizontal

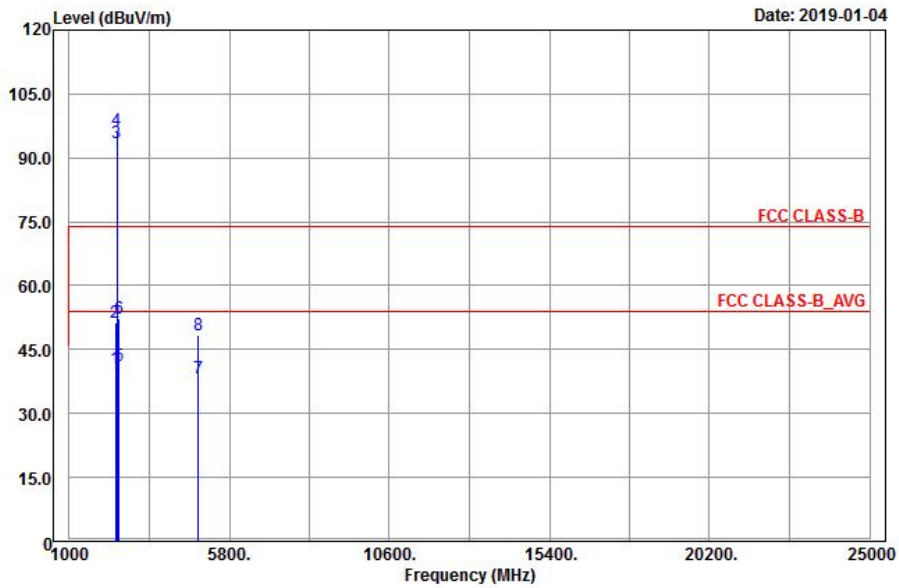

Vertical

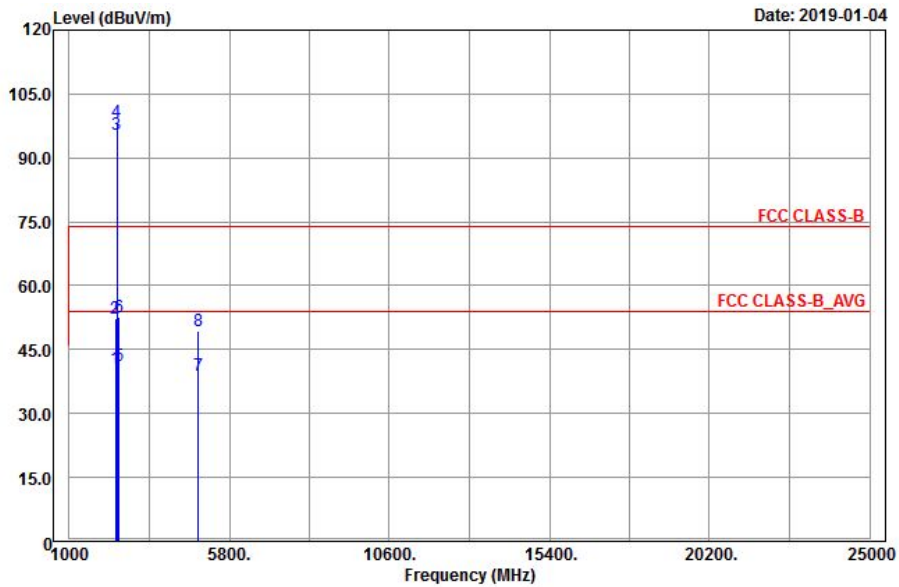

Antennal Polarity & Test Distance: Horizontal at 3 m

Frequency (MHz)	Emission Level (dBuV/m)	Read Level (dBuV)	Limit (dBuV/m)	Margin (dB)	Antenna Factor (dB/m)	Cable Loss (dB)	Preamp Factor (dB)	Antenna Height (cm)	Table Angle (Degree)	Remark
2385.87	40.46	34.02	54	-13.54	31.8	5.4	30.76	100	9	Average
2385.87	51.33	44.89	74	-22.67	31.8	5.4	30.76	100	9	Peak
2437	93.54	86.92			31.85	5.46	30.69	100	9	Average
2437	96.57	89.95			31.85	5.46	30.69	100	9	Peak
2493.32	41.27	34.42	54	-12.73	31.9	5.53	30.58	100	9	Average
2493.32	52.37	45.52	74	-21.63	31.9	5.53	30.58	100	9	Peak
4874	38.35	25.86	54	-15.65	33.98	8.27	29.76	133	162	Average
4874	48.3	35.81	74	-25.7	33.98	8.27	29.76	133	162	Peak

Antennal Polarity & Test Distance: Vertical at 3 m

Frequency (MHz)	Emission Level (dBuV/m)	Read Level (dBuV)	Limit (dBuV/m)	Margin (dB)	Antenna Factor (dB/m)	Cable Loss (dB)	Preamp Factor (dB)	Antenna Height (cm)	Table Angle (Degree)	Remark
2381.46	40.41	33.99	54	-13.59	31.78	5.4	30.76	277	299	Average
2381.46	52.43	46.01	74	-21.57	31.78	5.4	30.76	277	299	Peak
2437	95.55	88.93			31.85	5.46	30.69	277	299	Average
2437	98.27	91.65			31.85	5.46	30.69	277	299	Peak
2492.28	41.21	34.36	54	-12.79	31.9	5.53	30.58	277	299	Average
2492.28	52.54	45.69	74	-21.46	31.9	5.53	30.58	277	299	Peak
4874	39.06	26.57	54	-14.94	33.98	8.27	29.76	166	195	Average
4874	49.21	36.72	74	-24.79	33.98	8.27	29.76	166	195	Peak

Remarks:

- Emission Level = Read Level + Antenna Factor + Cable Loss - Preamp Factor
Margin value = Emission level – Limit value
- 2437 MHz: Fundamental frequency.
- The emission levels of other frequencies were very low against the limit.

EUT Test Condition		Measurement Detail	
Channel	Channel 11	Frequency Range	1 GHz ~ 25 GHz
Input Power	120 Vac, 60 Hz	Detector Function	Peak (PK) Average (AV)
Environmental Conditions	25 deg. C, 65 % RH	Tested By	Charles Hsiao

Horizontal

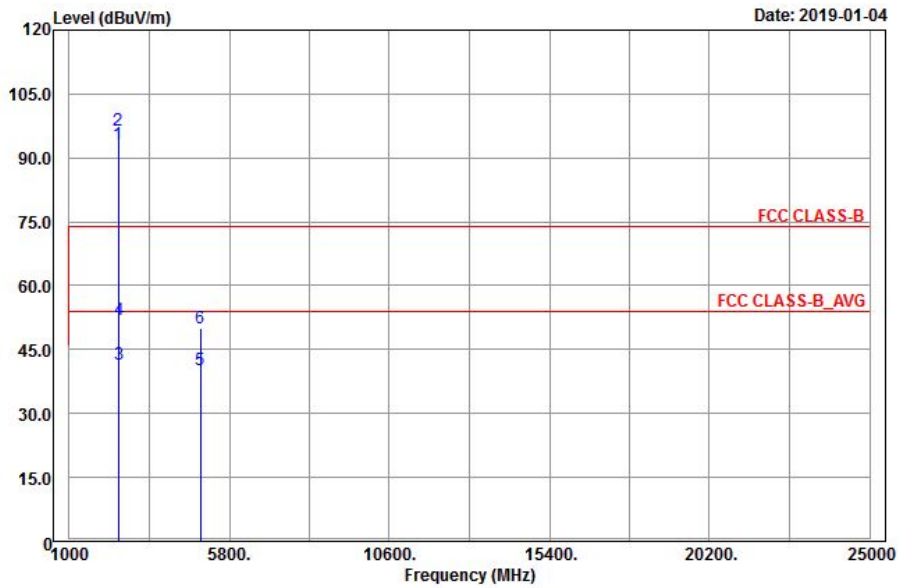

Vertical

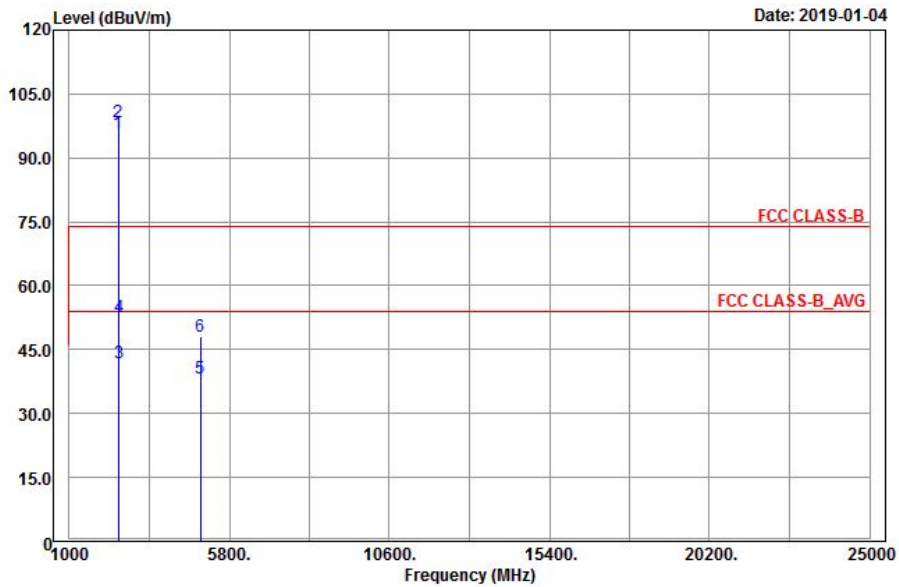

Antennal Polarity & Test Distance: Horizontal at 3 m

Frequency (MHz)	Emission Level (dBuV/m)	Read Level (dBuV)	Limit (dBuV/m)	Margin (dB)	Antenna Factor (dB/m)	Cable Loss (dB)	Preamp Factor (dB)	Antenna Height (cm)	Table Angle (Degree)	Remark
2462	93.22	86.5			31.87	5.5	30.65	100	9	Average
2462	96.35	89.63			31.87	5.5	30.65	100	9	Peak
2483.72	41.5	34.74	54	-12.5	31.88	5.5	30.62	100	9	Average
2483.72	51.86	45.1	74	-22.14	31.88	5.5	30.62	100	9	Peak
4924	40.1	27.56	54	-13.9	33.99	8.28	29.73	155	188	Average
4924	50.19	37.65	74	-23.81	33.99	8.28	29.73	155	188	Peak

Antennal Polarity & Test Distance: Vertical at 3 m

Frequency (MHz)	Emission Level (dBuV/m)	Read Level (dBuV)	Limit (dBuV/m)	Margin (dB)	Antenna Factor (dB/m)	Cable Loss (dB)	Preamp Factor (dB)	Antenna Height (cm)	Table Angle (Degree)	Remark
2462	95.66	88.94			31.87	5.5	30.65	277	299	Average
2462	98.55	91.83			31.87	5.5	30.65	277	299	Peak
2483.52	41.83	35.07	54	-12.17	31.88	5.5	30.62	277	299	Average
2483.52	52.74	45.98	74	-21.26	31.88	5.5	30.62	277	299	Peak
4924	38.19	25.65	54	-15.81	33.99	8.28	29.73	155	142	Average
4924	48.07	35.53	74	-25.93	33.99	8.28	29.73	155	142	Peak

Remarks:

- Emission Level = Read Level + Antenna Factor + Cable Loss - Preamp Factor
Margin value = Emission level – Limit value
- 2462 MHz: Fundamental frequency.
- The emission levels of other frequencies were very low against the limit.

EUT Test Condition		Measurement Detail	
Channel	Channel 12	Frequency Range	1 GHz ~ 25 GHz
Input Power	120 Vac, 60 Hz	Detector Function	Peak (PK) Average (AV)
Environmental Conditions	25 deg. C, 65 % RH	Tested By	Charles Hsiao

Horizontal

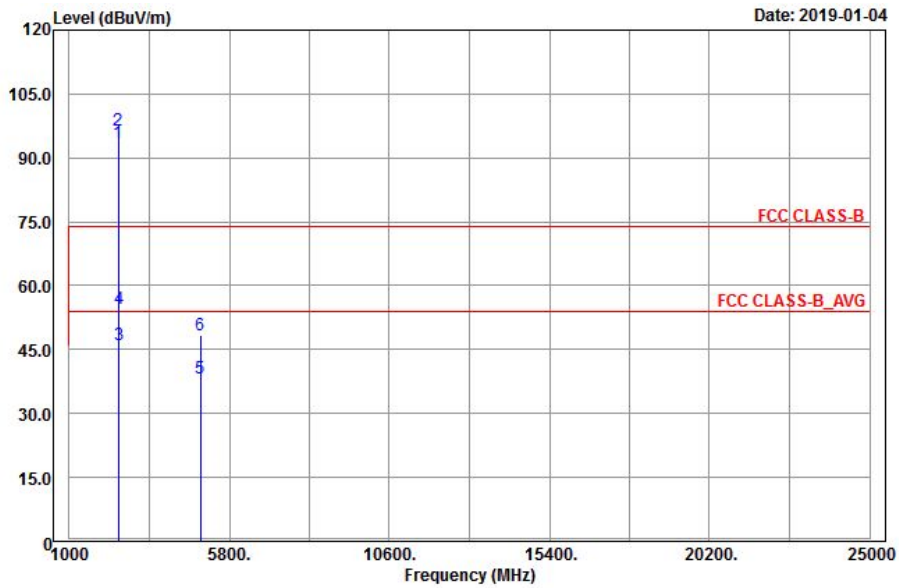

Vertical

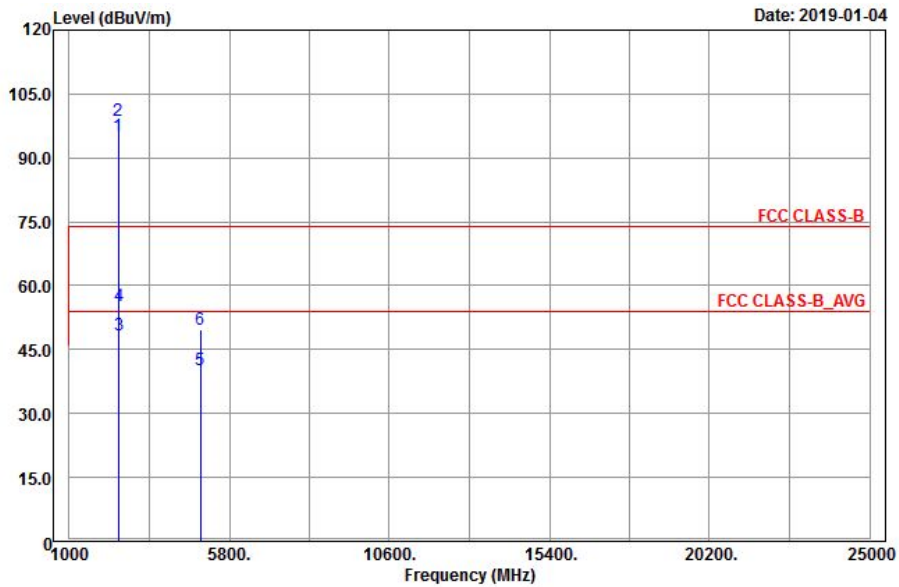

Antennal Polarity & Test Distance: Horizontal at 3 m

Frequency (MHz)	Emission Level (dBuV/m)	Read Level (dBuV)	Limit (dBuV/m)	Margin (dB)	Antenna Factor (dB/m)	Cable Loss (dB)	Preamp Factor (dB)	Antenna Height (cm)	Table Angle (Degree)	Remark
2467	93.44	86.69			31.87	5.5	30.62	100	9	Average
2467	96.31	89.56			31.87	5.5	30.62	100	9	Peak
2484.36	45.96	39.17	54	-8.04	31.88	5.53	30.62	100	9	Average
2484.36	54.68	47.89	74	-19.32	31.88	5.53	30.62	100	9	Peak
4934	38.11	25.56	54	-15.89	33.99	8.29	29.73	166	197	Average
4934	48.43	35.88	74	-25.57	33.99	8.29	29.73	166	197	Peak

Antennal Polarity & Test Distance: Vertical at 3 m

Frequency (MHz)	Emission Level (dBuV/m)	Read Level (dBuV)	Limit (dBuV/m)	Margin (dB)	Antenna Factor (dB/m)	Cable Loss (dB)	Preamp Factor (dB)	Antenna Height (cm)	Table Angle (Degree)	Remark
2467	95.22	88.47			31.87	5.5	30.62	277	299	Average
2467	98.68	91.93			31.87	5.5	30.62	277	299	Peak
2484.52	48.31	41.52	54	-5.69	31.88	5.53	30.62	277	299	Average
2484.52	55.15	48.36	74	-18.85	31.88	5.53	30.62	277	299	Peak
4934	40.14	27.59	54	-13.86	33.99	8.29	29.73	177	184	Average
4934	49.72	37.17	74	-24.28	33.99	8.29	29.73	177	184	Peak

Remarks:

- Emission Level = Read Level + Antenna Factor + Cable Loss - Preamp Factor
Margin value = Emission level – Limit value
- 2467 MHz: Fundamental frequency.
- The emission levels of other frequencies were very low against the limit.

EUT Test Condition		Measurement Detail	
Channel	Channel 13	Frequency Range	1 GHz ~ 25 GHz
Input Power	120 Vac, 60 Hz	Detector Function	Peak (PK) Average (AV)
Environmental Conditions	25 deg. C, 65 % RH	Tested By	Charles Hsiao

Horizontal

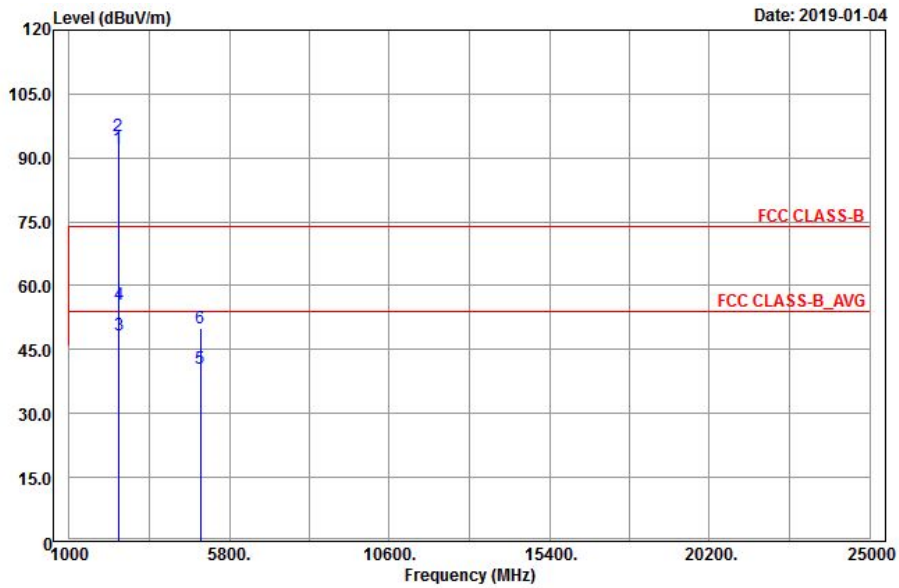

Vertical

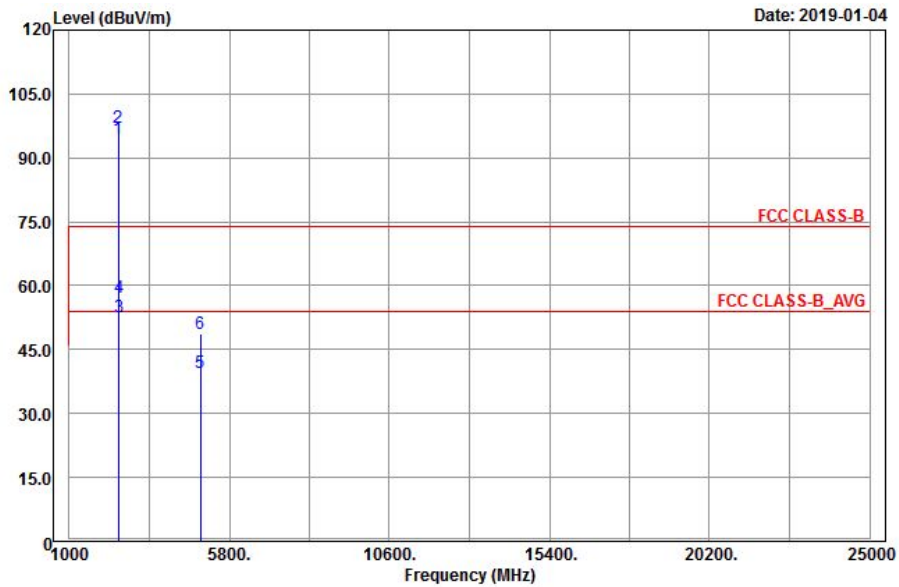

Antennal Polarity & Test Distance: Horizontal at 3 m

Frequency (MHz)	Emission Level (dBuV/m)	Read Level (dBuV)	Limit (dBuV/m)	Margin (dB)	Antenna Factor (dB/m)	Cable Loss (dB)	Preamp Factor (dB)	Antenna Height (cm)	Table Angle (Degree)	Remark
2472	92.22	85.46			31.88	5.5	30.62	100	9	Average
2472	95	88.24			31.88	5.5	30.62	100	9	Peak
2485.24	48.35	41.56	54	-5.65	31.88	5.53	30.62	100	9	Average
2485.24	55.72	48.93	74	-18.28	31.88	5.53	30.62	100	9	Peak
4944	40.42	27.86	54	-13.58	33.99	8.29	29.72	155	121	Average
4944	49.94	37.38	74	-24.06	33.99	8.29	29.72	155	121	Peak

Antennal Polarity & Test Distance: Vertical at 3 m

Frequency (MHz)	Emission Level (dBuV/m)	Read Level (dBuV)	Limit (dBuV/m)	Margin (dB)	Antenna Factor (dB/m)	Cable Loss (dB)	Preamp Factor (dB)	Antenna Height (cm)	Table Angle (Degree)	Remark
2472	94.63	87.87			31.88	5.5	30.62	244	299	Average
2472	97.1	90.34			31.88	5.5	30.62	244	299	Peak
2486.52	52.61	45.82	54	-1.39	31.88	5.53	30.62	244	299	Average
2486.52	57.07	50.28	74	-16.93	31.88	5.53	30.62	244	299	Peak
4944	39.53	26.97	54	-14.47	33.99	8.29	29.72	166	136	Average
4944	48.71	36.15	74	-25.29	33.99	8.29	29.72	166	136	Peak

Remarks:

- Emission Level = Read Level + Antenna Factor + Cable Loss - Preamp Factor
Margin value = Emission level – Limit value
- 2472 MHz: Fundamental frequency.
- The emission levels of other frequencies were very low against the limit.

802.11g

EUT Test Condition		Measurement Detail	
Channel	Channel 1	Frequency Range	1 GHz ~ 25 GHz
Input Power	120 Vac, 60 Hz	Detector Function	Peak (PK) Average (AV)
Environmental Conditions	25 deg. C, 65 % RH	Tested By	Charles Hsiao

Horizontal

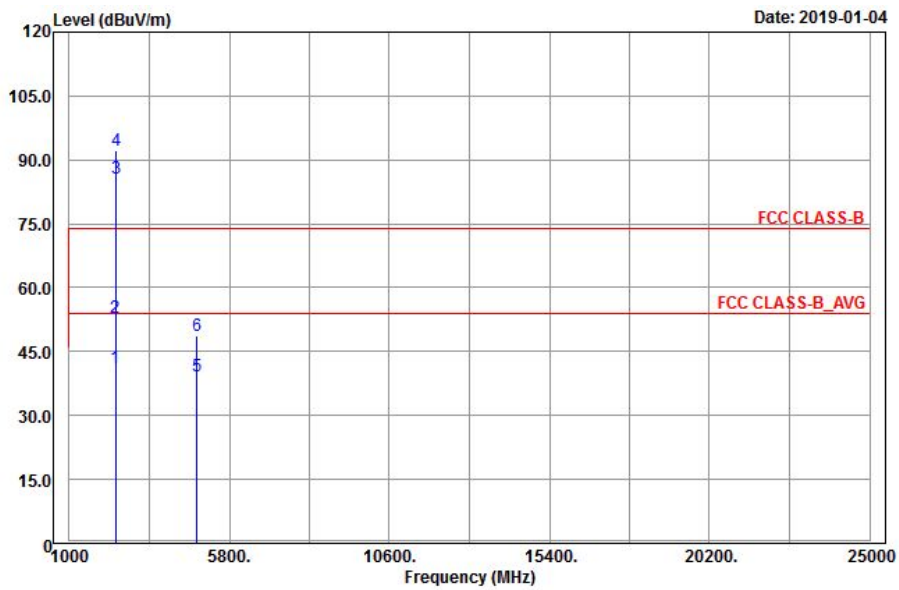

Vertical

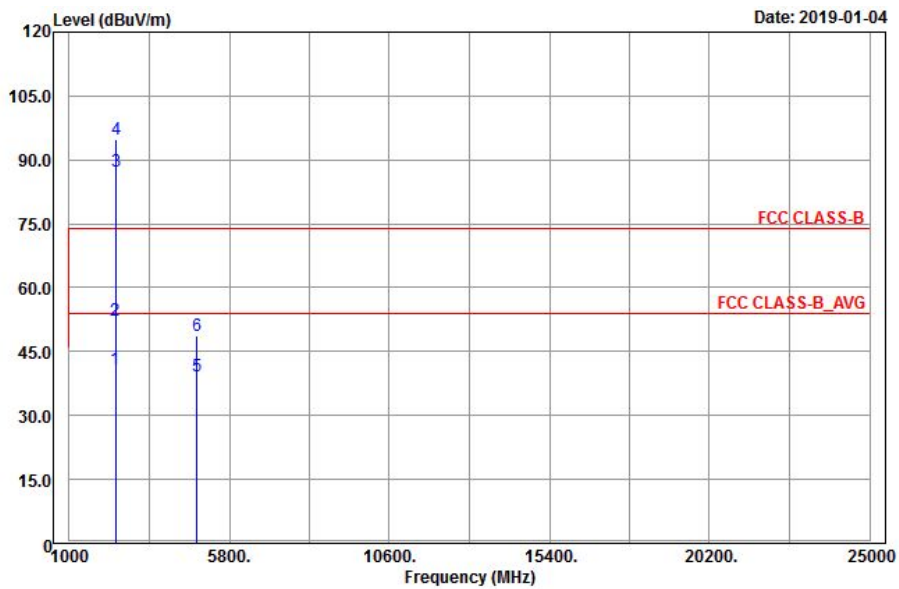

Antennal Polarity & Test Distance: Horizontal at 3 m

Frequency (MHz)	Emission Level (dBuV/m)	Read Level (dBuV)	Limit (dBuV/m)	Margin (dB)	Antenna Factor (dB/m)	Cable Loss (dB)	Preamp Factor (dB)	Antenna Height (cm)	Table Angle (Degree)	Remark
2389.83	41.15	34.68	54	-12.85	31.8	5.4	30.73	100	9	Average
2389.83	53.01	46.54	74	-20.99	31.8	5.4	30.73	100	9	Peak
2412	85.55	79.04			31.81	5.43	30.73	100	9	Average
2412	92.27	85.76			31.81	5.43	30.73	100	9	Peak
4824	39.28	26.83	54	-14.72	33.97	8.26	29.78	124	154	Average
4824	48.83	36.38	74	-25.17	33.97	8.26	29.78	124	154	Peak

Antennal Polarity & Test Distance: Vertical at 3 m

Frequency (MHz)	Emission Level (dBuV/m)	Read Level (dBuV)	Limit (dBuV/m)	Margin (dB)	Antenna Factor (dB/m)	Cable Loss (dB)	Preamp Factor (dB)	Antenna Height (cm)	Table Angle (Degree)	Remark
2389.74	40.99	34.55	54	-13.01	31.8	5.4	30.76	277	299	Average
2389.74	52.35	45.91	74	-21.65	31.8	5.4	30.76	277	299	Peak
2412	87.44	80.93			31.81	5.43	30.73	277	299	Average
2412	94.84	88.33			31.81	5.43	30.73	277	299	Peak
4824	39.28	26.83	54	-14.72	33.97	8.26	29.78	159	187	Average
4824	48.67	36.22	74	-25.33	33.97	8.26	29.78	159	187	Peak

Remarks:

- Emission Level = Read Level + Antenna Factor + Cable Loss - Preamp Factor
Margin value = Emission level – Limit value
- 2412 MHz: Fundamental frequency.
- The emission levels of other frequencies were very low against the limit.

EUT Test Condition		Measurement Detail	
Channel	Channel 6	Frequency Range	1 GHz ~ 25 GHz
Input Power	120 Vac, 60 Hz	Detector Function	Peak (PK) Average (AV)
Environmental Conditions	25 deg. C, 65 % RH	Tested By	Charles Hsiao

Horizontal

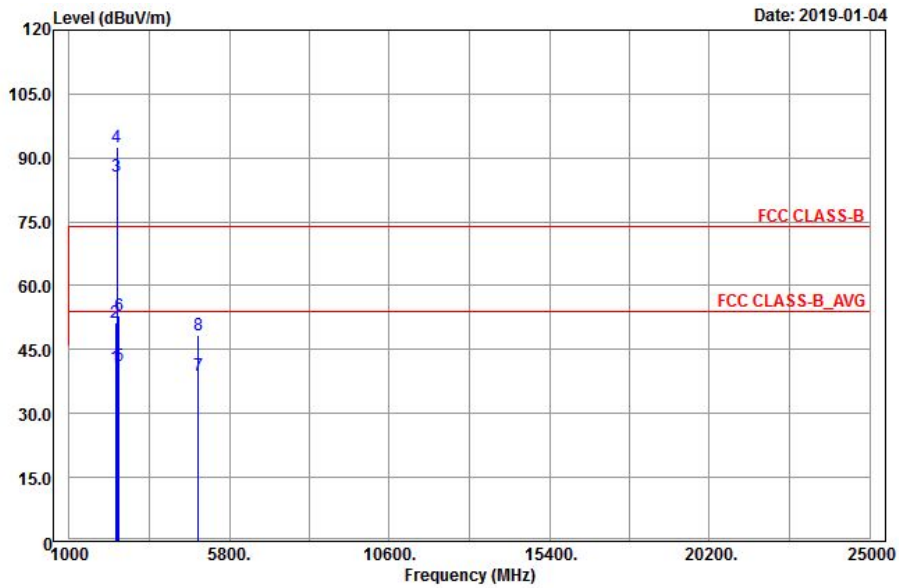

Vertical

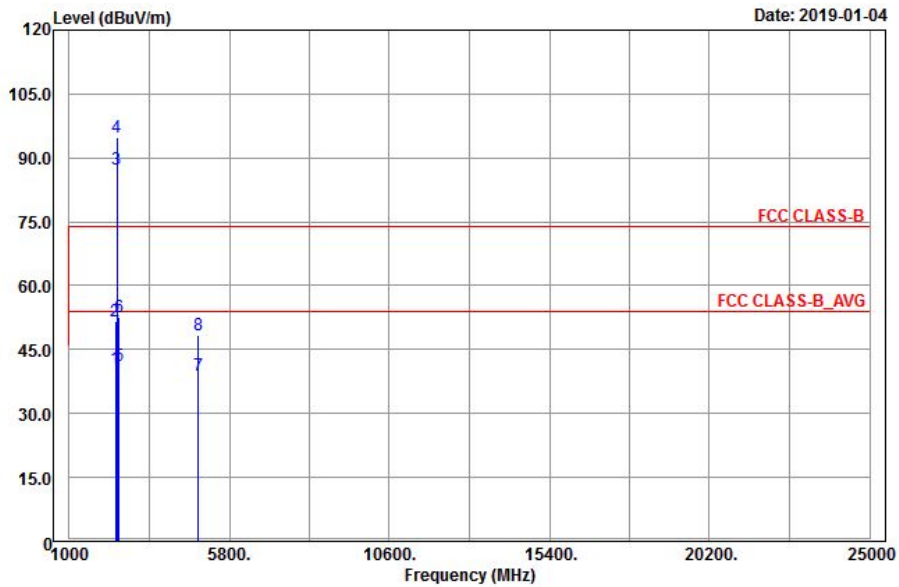

Antennal Polarity & Test Distance: Horizontal at 3 m

Frequency (MHz)	Emission Level (dBuV/m)	Read Level (dBuV)	Limit (dBuV/m)	Margin (dB)	Antenna Factor (dB/m)	Cable Loss (dB)	Preamp Factor (dB)	Antenna Height (cm)	Table Angle (Degree)	Remark
2384.88	40.71	34.29	54	-13.29	31.78	5.4	30.76	100	9	Average
2384.88	51.29	44.87	74	-22.71	31.78	5.4	30.76	100	9	Peak
2437	85.77	79.15			31.85	5.46	30.69	100	9	Average
2437	92.67	86.05			31.85	5.46	30.69	100	9	Peak
2489.08	41.11	34.3	54	-12.89	31.9	5.53	30.62	100	9	Average
2489.08	52.85	46.04	74	-21.15	31.9	5.53	30.62	100	9	Peak
4874	39.02	26.53	54	-14.98	33.98	8.27	29.76	166	198	Average
4874	48.44	35.95	74	-25.56	33.98	8.27	29.76	166	198	Peak

Antennal Polarity & Test Distance: Vertical at 3 m

Frequency (MHz)	Emission Level (dBuV/m)	Read Level (dBuV)	Limit (dBuV/m)	Margin (dB)	Antenna Factor (dB/m)	Cable Loss (dB)	Preamp Factor (dB)	Antenna Height (cm)	Table Angle (Degree)	Remark
2384.25	40.53	34.11	54	-13.47	31.78	5.4	30.76	277	299	Average
2384.25	51.63	45.21	74	-22.37	31.78	5.4	30.76	277	299	Peak
2437	87.41	80.79			31.85	5.46	30.69	277	299	Average
2437	94.92	88.3			31.85	5.46	30.69	277	299	Peak
2488.6	41.29	34.48	54	-12.71	31.9	5.53	30.62	277	299	Average
2488.6	52.62	45.81	74	-21.38	31.9	5.53	30.62	277	299	Peak
4874	39.04	26.55	54	-14.96	33.98	8.27	29.76	177	184	Average
4874	48.31	35.82	74	-25.69	33.98	8.27	29.76	177	184	Peak

Remarks:

- Emission Level = Read Level + Antenna Factor + Cable Loss - Preamp Factor
Margin value = Emission level – Limit value
- 2437 MHz: Fundamental frequency.
- The emission levels of other frequencies were very low against the limit.

EUT Test Condition		Measurement Detail	
Channel	Channel 11	Frequency Range	1 GHz ~ 25 GHz
Input Power	120 Vac, 60 Hz	Detector Function	Peak (PK) Average (AV)
Environmental Conditions	25 deg. C, 65 % RH	Tested By	Charles Hsiao

Horizontal

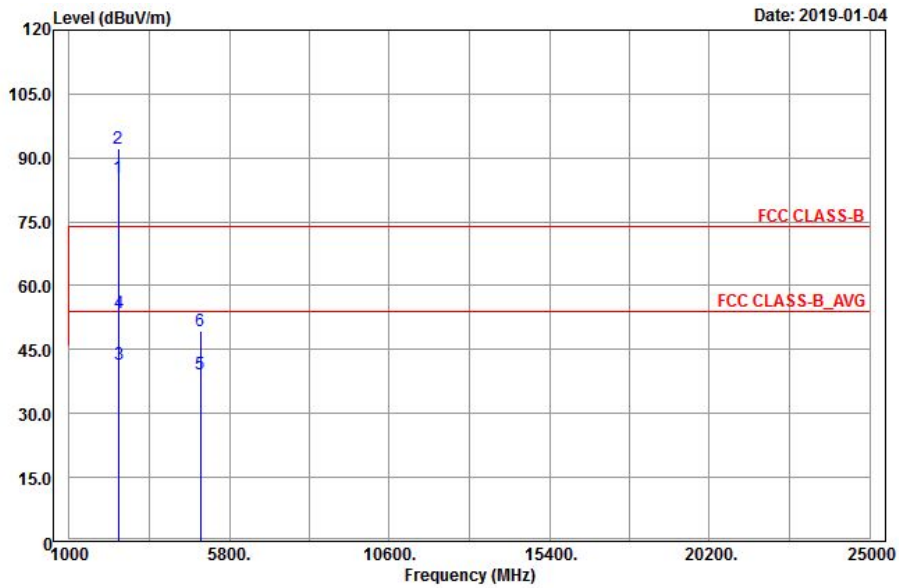

Vertical

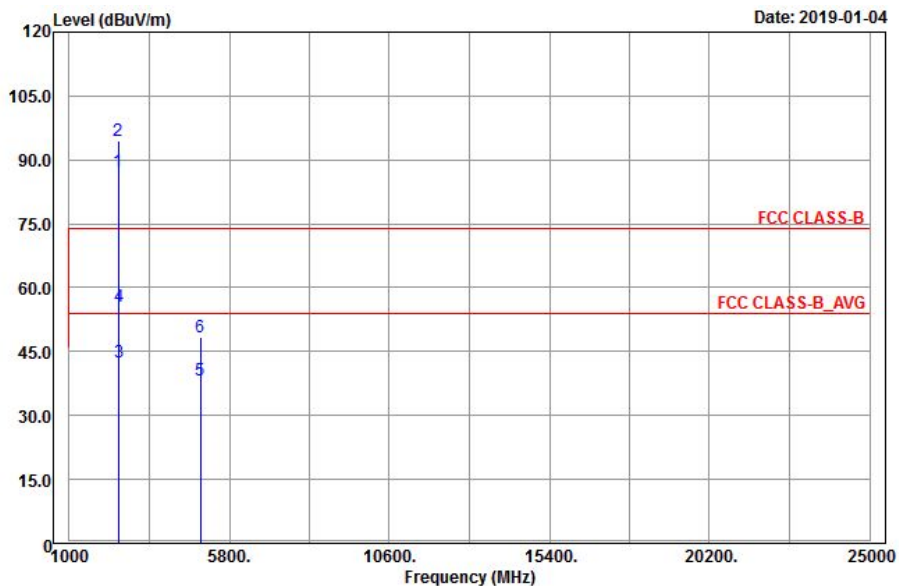

Antennal Polarity & Test Distance: Horizontal at 3 m

Frequency (MHz)	Emission Level (dBuV/m)	Read Level (dBuV)	Limit (dBuV/m)	Margin (dB)	Antenna Factor (dB/m)	Cable Loss (dB)	Preamp Factor (dB)	Antenna Height (cm)	Table Angle (Degree)	Remark
2462	85.21	78.49			31.87	5.5	30.65	100	9	Average
2462	92.21	85.49			31.87	5.5	30.65	100	9	Peak
2483.52	41.66	34.9	54	-12.34	31.88	5.5	30.62	100	9	Average
2483.52	53.66	46.9	74	-20.34	31.88	5.5	30.62	100	9	Peak
4924	39.11	26.57	54	-14.89	33.99	8.28	29.73	144	174	Average
4924	49.37	36.83	74	-24.63	33.99	8.28	29.73	144	174	Peak

Antennal Polarity & Test Distance: Vertical at 3 m

Frequency (MHz)	Emission Level (dBuV/m)	Read Level (dBuV)	Limit (dBuV/m)	Margin (dB)	Antenna Factor (dB/m)	Cable Loss (dB)	Preamp Factor (dB)	Antenna Height (cm)	Table Angle (Degree)	Remark
2462	87.35	80.63			31.87	5.5	30.65	201	299	Average
2462	94.49	87.77			31.87	5.5	30.65	201	299	Peak
2483.96	42.54	35.78	54	-11.46	31.88	5.5	30.62	201	299	Average
2483.96	55.71	48.95	74	-18.29	31.88	5.5	30.62	201	299	Peak
4924	38.2	25.66	54	-15.8	33.99	8.28	29.73	155	125	Average
4924	48.35	35.81	74	-25.65	33.99	8.28	29.73	155	125	Peak

Remarks:

1. Emission Level = Read Level + Antenna Factor + Cable Loss - Preamp Factor
Margin value = Emission level – Limit value
2. 2462 MHz: Fundamental frequency.
3. The emission levels of other frequencies were very low against the limit.

EUT Test Condition		Measurement Detail	
Channel	Channel 12	Frequency Range	1 GHz ~ 25 GHz
Input Power	120 Vac, 60 Hz	Detector Function	Peak (PK) Average (AV)
Environmental Conditions	25 deg. C, 65 % RH	Tested By	Charles Hsiao

Horizontal

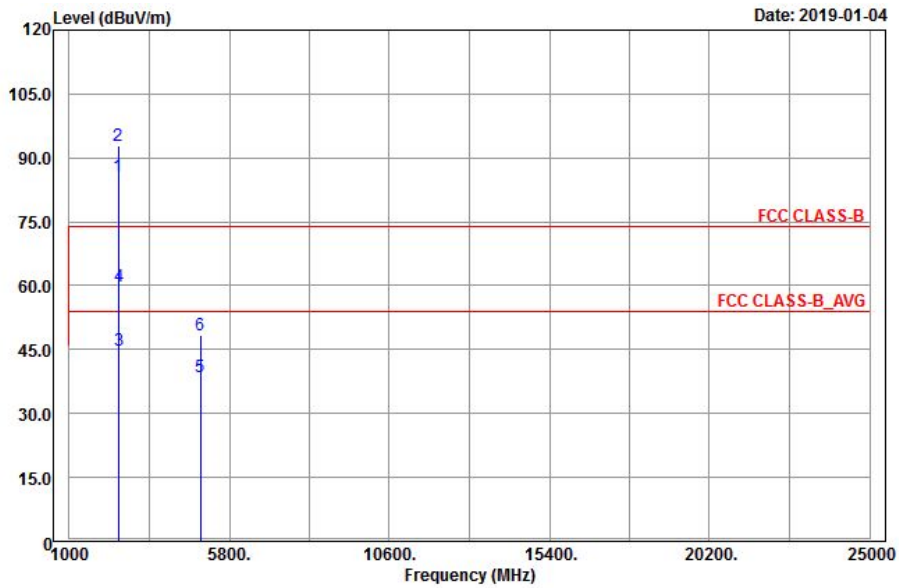

Vertical

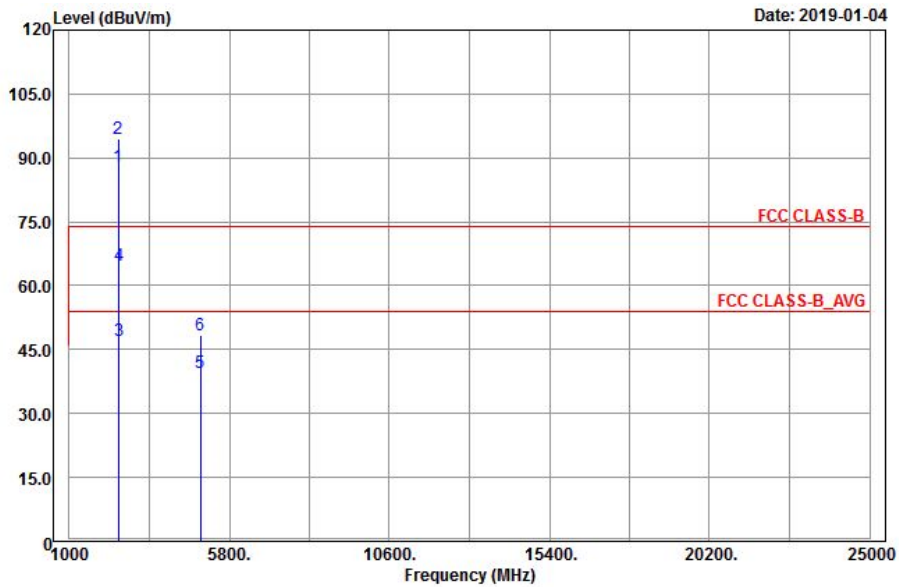

Antennal Polarity & Test Distance: Horizontal at 3 m

Frequency (MHz)	Emission Level (dBuV/m)	Read Level (dBuV)	Limit (dBuV/m)	Margin (dB)	Antenna Factor (dB/m)	Cable Loss (dB)	Preamp Factor (dB)	Antenna Height (cm)	Table Angle (Degree)	Remark
2467	85.55	78.8			31.87	5.5	30.62	100	9	Average
2467	92.84	86.09			31.87	5.5	30.62	100	9	Peak
2483.56	44.86	38.1	54	-9.14	31.88	5.5	30.62	100	9	Average
2483.56	59.76	53	74	-14.24	31.88	5.5	30.62	100	9	Peak
4934	38.51	25.96	54	-15.49	33.99	8.29	29.73	166	175	Average
4934	48.41	35.86	74	-25.59	33.99	8.29	29.73	166	175	Peak

Antennal Polarity & Test Distance: Vertical at 3 m

Frequency (MHz)	Emission Level (dBuV/m)	Read Level (dBuV)	Limit (dBuV/m)	Margin (dB)	Antenna Factor (dB/m)	Cable Loss (dB)	Preamp Factor (dB)	Antenna Height (cm)	Table Angle (Degree)	Remark
2467	87.89	81.14			31.87	5.5	30.62	231	299	Average
2467	94.46	87.71			31.87	5.5	30.62	231	299	Peak
2483.52	46.98	40.22	54	-7.02	31.88	5.5	30.62	231	299	Average
2483.52	64.78	58.02	74	-9.22	31.88	5.5	30.62	231	299	Peak
4934	39.51	26.96	54	-14.49	33.99	8.29	29.73	177	185	Average
4934	48.55	36	74	-25.45	33.99	8.29	29.73	177	185	Peak

Remarks:

- Emission Level = Read Level + Antenna Factor + Cable Loss - Preamp Factor
Margin value = Emission level – Limit value
- 2467 MHz: Fundamental frequency.
- The emission levels of other frequencies were very low against the limit.

EUT Test Condition		Measurement Detail	
Channel	Channel 13	Frequency Range	1 GHz ~ 25 GHz
Input Power	120 Vac, 60 Hz	Detector Function	Peak (PK) Average (AV)
Environmental Conditions	25 deg. C, 65 % RH	Tested By	Charles Hsiao

Horizontal

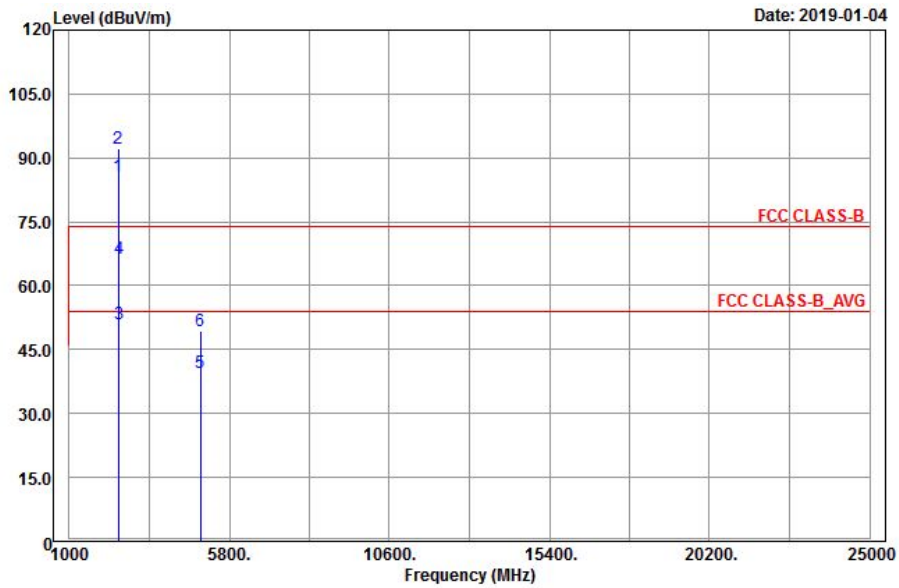

Vertical

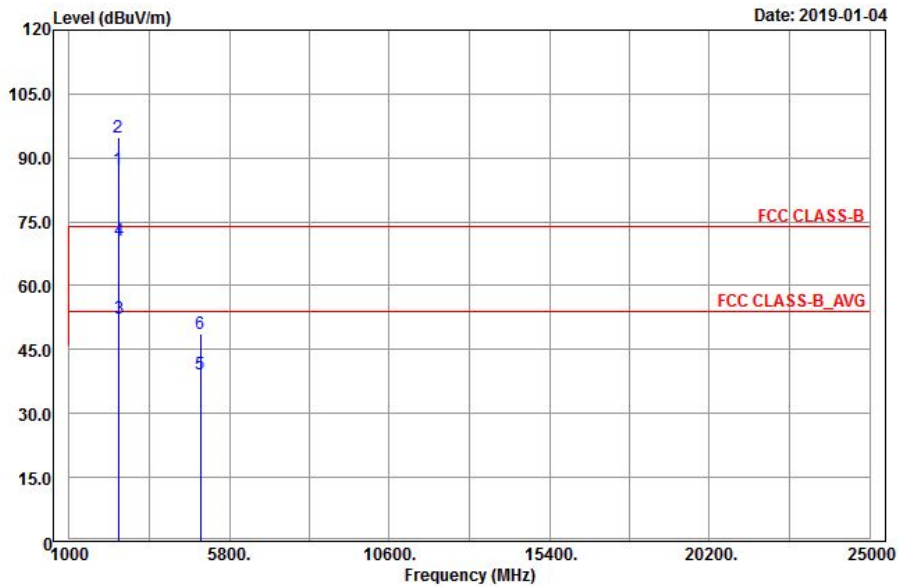

Antennal Polarity & Test Distance: Horizontal at 3 m

Frequency (MHz)	Emission Level (dBuV/m)	Read Level (dBuV)	Limit (dBuV/m)	Margin (dB)	Antenna Factor (dB/m)	Cable Loss (dB)	Preamp Factor (dB)	Antenna Height (cm)	Table Angle (Degree)	Remark
2472	85.77	79.01			31.88	5.5	30.62	100	9	Average
2472	92.17	85.41			31.88	5.5	30.62	100	9	Peak
2483.52	51.01	44.25	54	-2.99	31.88	5.5	30.62	100	9	Average
2483.52	66.53	59.77	74	-7.47	31.88	5.5	30.62	100	9	Peak
4944	39.42	26.86	54	-14.58	33.99	8.29	29.72	153	162	Average
4944	49.28	36.72	74	-24.72	33.99	8.29	29.72	153	162	Peak

Antennal Polarity & Test Distance: Vertical at 3 m

Frequency (MHz)	Emission Level (dBuV/m)	Read Level (dBuV)	Limit (dBuV/m)	Margin (dB)	Antenna Factor (dB/m)	Cable Loss (dB)	Preamp Factor (dB)	Antenna Height (cm)	Table Angle (Degree)	Remark
2472	87.45	80.69			31.88	5.5	30.62	228	299	Average
2472	94.91	88.15			31.88	5.5	30.62	228	299	Peak
2483.52	52.35	45.59	54	-1.65	31.88	5.5	30.62	228	299	Average
2483.52	70.57	63.81	74	-3.43	31.88	5.5	30.62	228	299	Peak
4944	39.34	26.78	54	-14.66	33.99	8.29	29.72	178	184	Average
4944	48.83	36.27	74	-25.17	33.99	8.29	29.72	178	184	Peak

Remarks:

- Emission Level = Read Level + Antenna Factor + Cable Loss - Preamp Factor
Margin value = Emission level – Limit value
- 2472 MHz: Fundamental frequency.
- The emission levels of other frequencies were very low against the limit.

802.11n (HT20)

EUT Test Condition		Measurement Detail	
Channel	Channel 1	Frequency Range	1 GHz ~ 25 GHz
Input Power	120 Vac, 60 Hz	Detector Function	Peak (PK) Average (AV)
Environmental Conditions	25 deg. C, 65 % RH	Tested By	Charles Hsiao

Horizontal

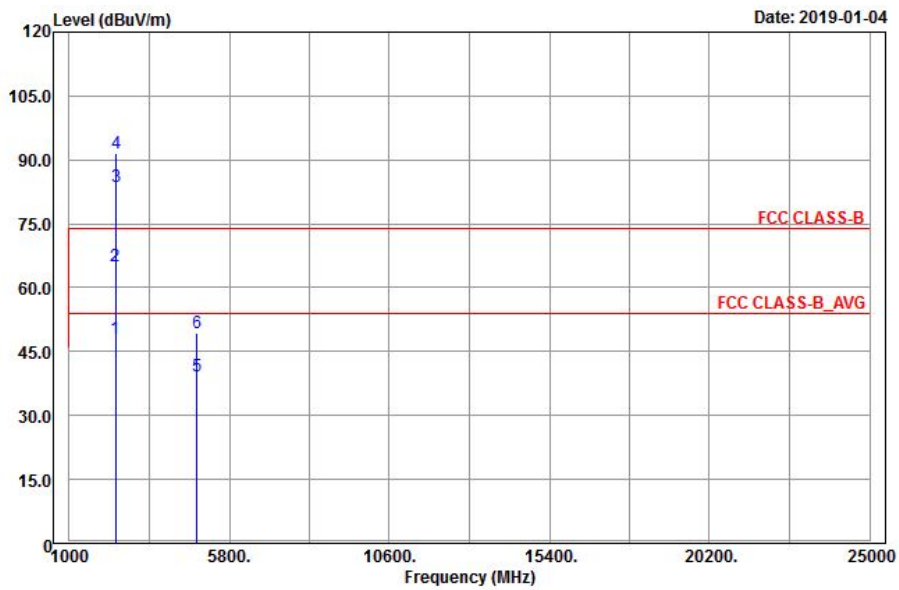

Vertical

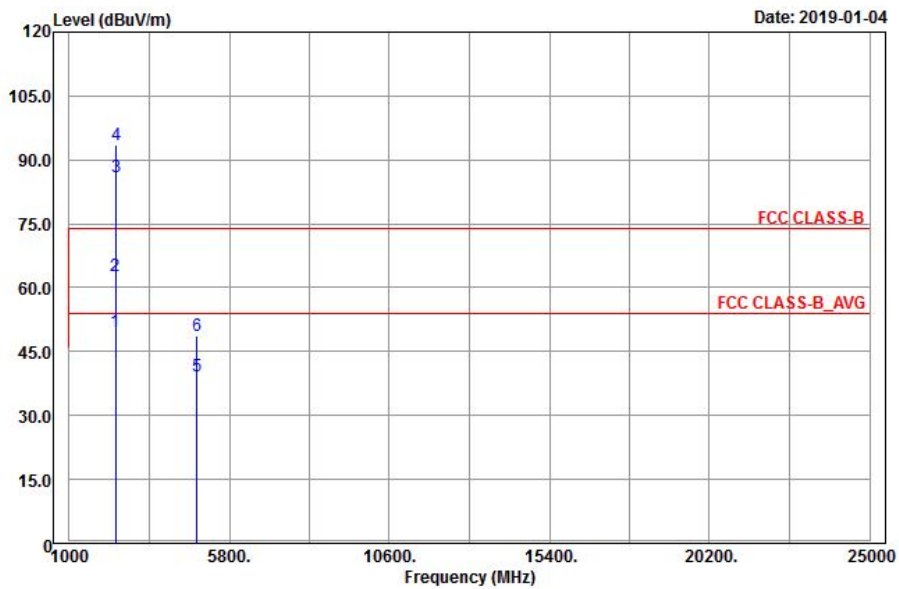

Antennal Polarity & Test Distance: Horizontal at 3 m

Frequency (MHz)	Emission Level (dBuV/m)	Read Level (dBuV)	Limit (dBuV/m)	Margin (dB)	Antenna Factor (dB/m)	Cable Loss (dB)	Preamp Factor (dB)	Antenna Height (cm)	Table Angle (Degree)	Remark
2389.83	48.21	41.74	54	-5.79	31.8	5.4	30.73	100	9	Average
2389.83	65.11	58.64	74	-8.89	31.8	5.4	30.73	100	9	Peak
2412	83.81	77.3			31.81	5.43	30.73	100	9	Average
2412	91.51	85			31.81	5.43	30.73	100	9	Peak
4824	39.3	26.85	54	-14.7	33.97	8.26	29.78	166	195	Average
4824	49.3	36.85	74	-24.7	33.97	8.26	29.78	166	195	Peak

Antennal Polarity & Test Distance: Vertical at 3 m

Frequency (MHz)	Emission Level (dBuV/m)	Read Level (dBuV)	Limit (dBuV/m)	Margin (dB)	Antenna Factor (dB/m)	Cable Loss (dB)	Preamp Factor (dB)	Antenna Height (cm)	Table Angle (Degree)	Remark
2389.92	49.78	43.31	54	-4.22	31.8	5.4	30.73	277	299	Average
2389.92	62.78	56.31	74	-11.22	31.8	5.4	30.73	277	299	Peak
2412	86.1	79.59			31.81	5.43	30.73	277	299	Average
2412	93.64	87.13			31.81	5.43	30.73	277	299	Peak
4824	39.3	26.85	54	-14.7	33.97	8.26	29.78	142	174	Average
4824	48.56	36.11	74	-25.44	33.97	8.26	29.78	142	174	Peak

Remarks:

- Emission Level = Read Level + Antenna Factor + Cable Loss - Preamp Factor
Margin value = Emission level – Limit value
- 2412 MHz: Fundamental frequency.
- The emission levels of other frequencies were very low against the limit.

EUT Test Condition		Measurement Detail	
Channel	Channel 6	Frequency Range	1 GHz ~ 25 GHz
Input Power	120 Vac, 60 Hz	Detector Function	Peak (PK) Average (AV)
Environmental Conditions	25 deg. C, 65 % RH	Tested By	Charles Hsiao

Horizontal

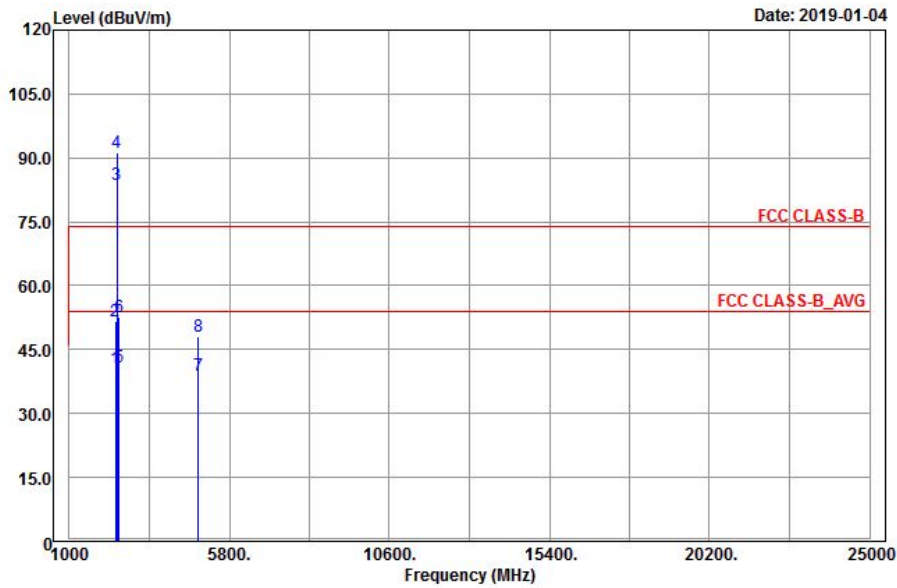

Vertical

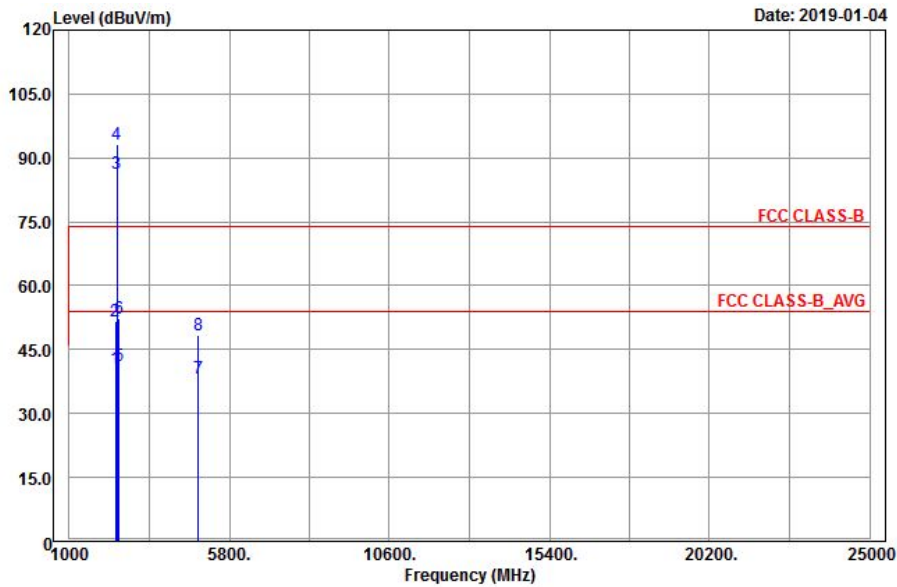

Antennal Polarity & Test Distance: Horizontal at 3 m

Frequency (MHz)	Emission Level (dBuV/m)	Read Level (dBuV)	Limit (dBuV/m)	Margin (dB)	Antenna Factor (dB/m)	Cable Loss (dB)	Preamp Factor (dB)	Antenna Height (cm)	Table Angle (Degree)	Remark
2385.6	40.46	34.02	54	-13.54	31.8	5.4	30.76	100	9	Average
2385.6	51.65	45.21	74	-22.35	31.8	5.4	30.76	100	9	Peak
2437	83.84	77.22			31.85	5.46	30.69	100	9	Average
2437	91.22	84.6			31.85	5.46	30.69	100	9	Peak
2489	41.03	34.22	54	-12.97	31.9	5.53	30.62	100	9	Average
2489	52.63	45.82	74	-21.37	31.9	5.53	30.62	100	9	Peak
4874	39.02	26.53	54	-14.98	33.98	8.27	29.76	166	195	Average
4874	47.96	35.47	74	-26.04	33.98	8.27	29.76	166	195	Peak

Antennal Polarity & Test Distance: Vertical at 3 m

Frequency (MHz)	Emission Level (dBuV/m)	Read Level (dBuV)	Limit (dBuV/m)	Margin (dB)	Antenna Factor (dB/m)	Cable Loss (dB)	Preamp Factor (dB)	Antenna Height (cm)	Table Angle (Degree)	Remark
2384.07	40.62	34.2	54	-13.38	31.78	5.4	30.76	277	360	Average
2384.07	51.51	45.09	74	-22.49	31.78	5.4	30.76	277	360	Peak
2437	86.17	79.55			31.85	5.46	30.69	277	360	Average
2437	93.11	86.49			31.85	5.46	30.69	277	360	Peak
2488.64	41.32	34.51	54	-12.68	31.9	5.53	30.62	277	360	Average
2488.64	52.29	45.48	74	-21.71	31.9	5.53	30.62	277	360	Peak
4874	38.15	25.66	54	-15.85	33.98	8.27	29.76	122	132	Average
4874	48.47	35.98	74	-25.53	33.98	8.27	29.76	122	132	Peak

Remarks:

1. Emission Level = Read Level + Antenna Factor + Cable Loss - Preamp Factor
Margin value = Emission level – Limit value
2. 2437 MHz: Fundamental frequency.
3. The emission levels of other frequencies were very low against the limit.

EUT Test Condition		Measurement Detail	
Channel	Channel 11	Frequency Range	1 GHz ~ 25 GHz
Input Power	120 Vac, 60 Hz	Detector Function	Peak (PK) Average (AV)
Environmental Conditions	25 deg. C, 65 % RH	Tested By	Charles Hsiao

Horizontal

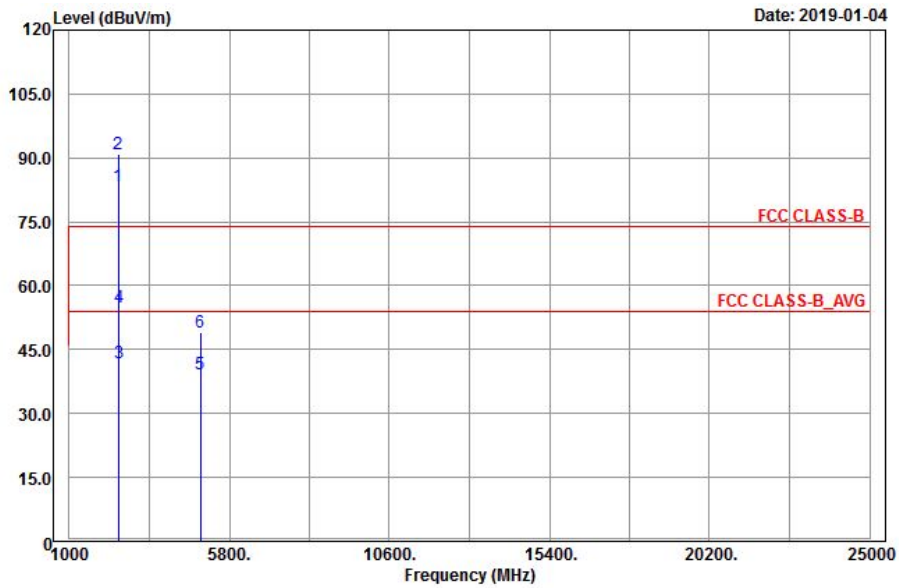

Vertical

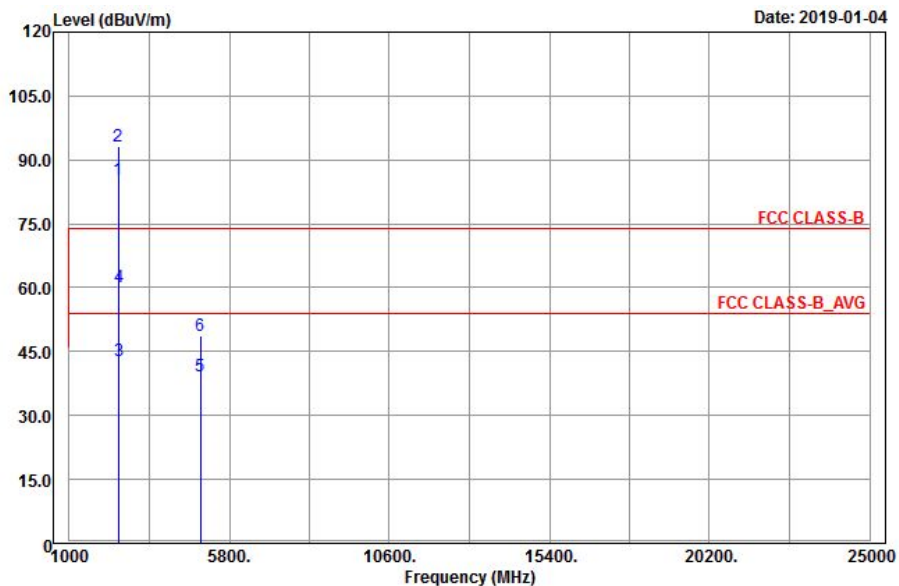

Antennal Polarity & Test Distance: Horizontal at 3 m

Frequency (MHz)	Emission Level (dBuV/m)	Read Level (dBuV)	Limit (dBuV/m)	Margin (dB)	Antenna Factor (dB/m)	Cable Loss (dB)	Preamp Factor (dB)	Antenna Height (cm)	Table Angle (Degree)	Remark
2462	83.22	76.5			31.87	5.5	30.65	100	9	Average
2462	91.04	84.32			31.87	5.5	30.65	100	9	Peak
2483.72	41.9	35.14	54	-12.1	31.88	5.5	30.62	100	9	Average
2483.72	54.81	48.05	74	-19.19	31.88	5.5	30.62	100	9	Peak
4924	39.11	26.57	54	-14.89	33.99	8.28	29.73	155	185	Average
4924	49.12	36.58	74	-24.88	33.99	8.28	29.73	155	185	Peak

Antennal Polarity & Test Distance: Vertical at 3 m

Frequency (MHz)	Emission Level (dBuV/m)	Read Level (dBuV)	Limit (dBuV/m)	Margin (dB)	Antenna Factor (dB/m)	Cable Loss (dB)	Preamp Factor (dB)	Antenna Height (cm)	Table Angle (Degree)	Remark
2462	85.22	78.5			31.87	5.5	30.65	277	360	Average
2462	93.35	86.63			31.87	5.5	30.65	277	360	Peak
2483.56	42.89	36.13	54	-11.11	31.88	5.5	30.62	277	360	Average
2483.56	60.28	53.52	74	-13.72	31.88	5.5	30.62	277	360	Peak
4924	39.11	26.57	54	-14.89	33.99	8.28	29.73	188	175	Average
4924	48.56	36.02	74	-25.44	33.99	8.28	29.73	188	175	Peak

Remarks:

- Emission Level = Read Level + Antenna Factor + Cable Loss - Preamp Factor
Margin value = Emission level – Limit value
- 2462 MHz: Fundamental frequency.
- The emission levels of other frequencies were very low against the limit.

EUT Test Condition		Measurement Detail	
Channel	Channel 12	Frequency Range	1 GHz ~ 25 GHz
Input Power	120 Vac, 60 Hz	Detector Function	Peak (PK) Average (AV)
Environmental Conditions	25 deg. C, 65 % RH	Tested By	Charles Hsiao

Horizontal

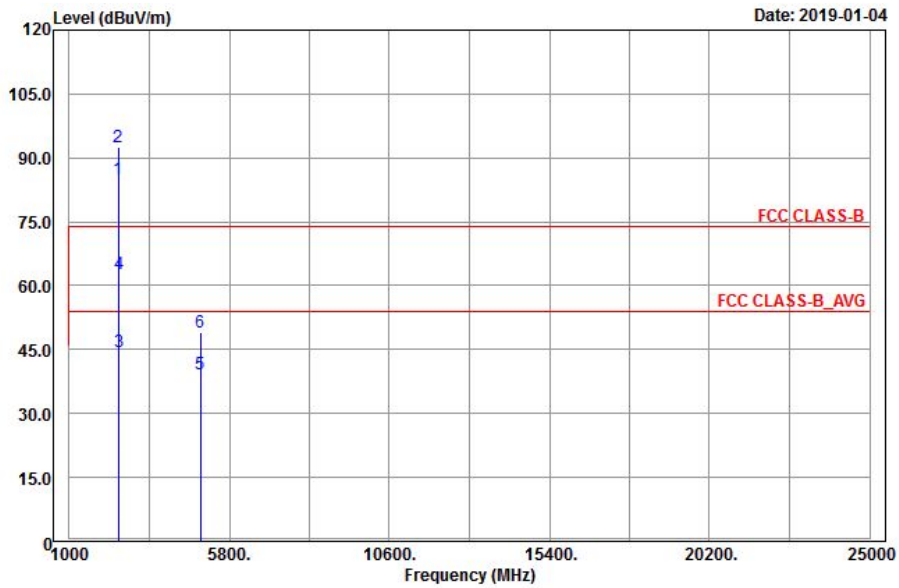

Vertical

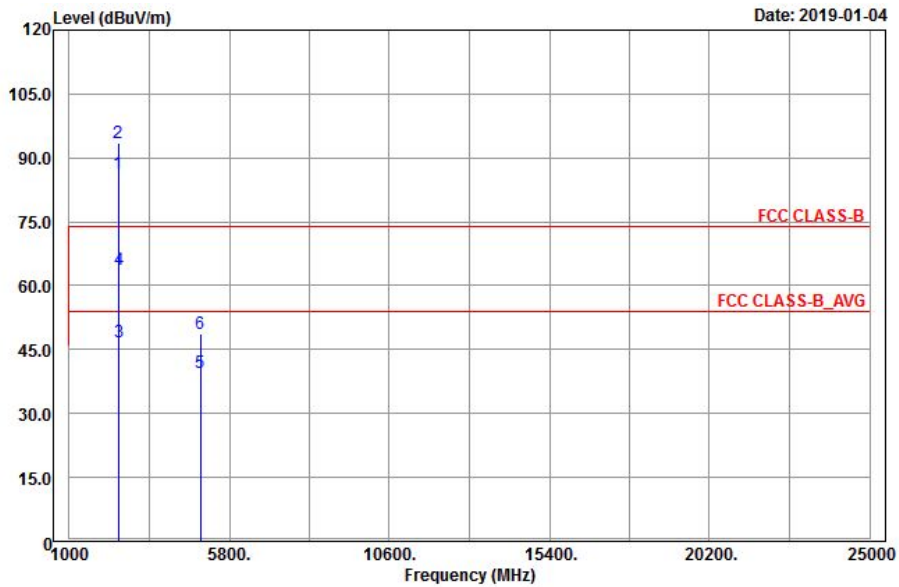

Antennal Polarity & Test Distance: Horizontal at 3 m

Frequency (MHz)	Emission Level (dBuV/m)	Read Level (dBuV)	Limit (dBuV/m)	Margin (dB)	Antenna Factor (dB/m)	Cable Loss (dB)	Preamp Factor (dB)	Antenna Height (cm)	Table Angle (Degree)	Remark
2467	84.93	78.18			31.87	5.5	30.62	100	9	Average
2467	92.48	85.73			31.87	5.5	30.62	100	9	Peak
2483.68	44.56	37.8	54	-9.44	31.88	5.5	30.62	100	9	Average
2483.68	62.83	56.07	74	-11.17	31.88	5.5	30.62	100	9	Peak
4934	39.14	26.59	54	-14.86	33.99	8.29	29.73	122	158	Average
4934	49.04	36.49	74	-24.96	33.99	8.29	29.73	122	158	Peak

Antennal Polarity & Test Distance: Vertical at 3 m

Frequency (MHz)	Emission Level (dBuV/m)	Read Level (dBuV)	Limit (dBuV/m)	Margin (dB)	Antenna Factor (dB/m)	Cable Loss (dB)	Preamp Factor (dB)	Antenna Height (cm)	Table Angle (Degree)	Remark
2467	86.22	79.47			31.87	5.5	30.62	277	360	Average
2467	93.49	86.74			31.87	5.5	30.62	277	360	Peak
2483.56	46.8	40.04	54	-7.2	31.88	5.5	30.62	277	360	Average
2483.56	63.81	57.05	74	-10.19	31.88	5.5	30.62	277	360	Peak
4934	39.44	26.89	54	-14.56	33.99	8.29	29.73	177	184	Average
4934	48.86	36.31	74	-25.14	33.99	8.29	29.73	177	184	Peak

Remarks:

- Emission Level = Read Level + Antenna Factor + Cable Loss - Preamp Factor
Margin value = Emission level – Limit value
- 2467 MHz: Fundamental frequency.
- The emission levels of other frequencies were very low against the limit.

EUT Test Condition		Measurement Detail	
Channel	Channel 13	Frequency Range	1 GHz ~ 25 GHz
Input Power	120 Vac, 60 Hz	Detector Function	Peak (PK) Average (AV)
Environmental Conditions	25 deg. C, 65 % RH	Tested By	Charles Hsiao

Horizontal

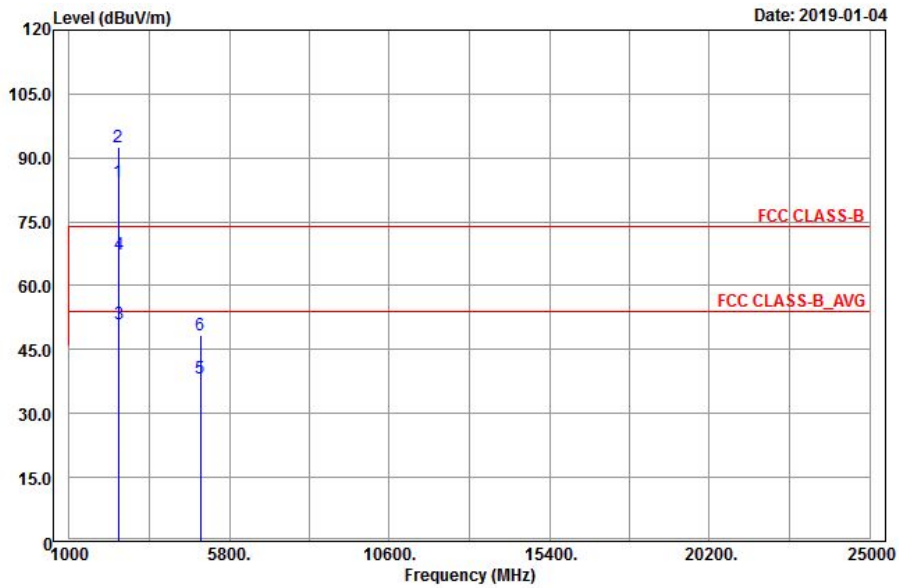

Vertical

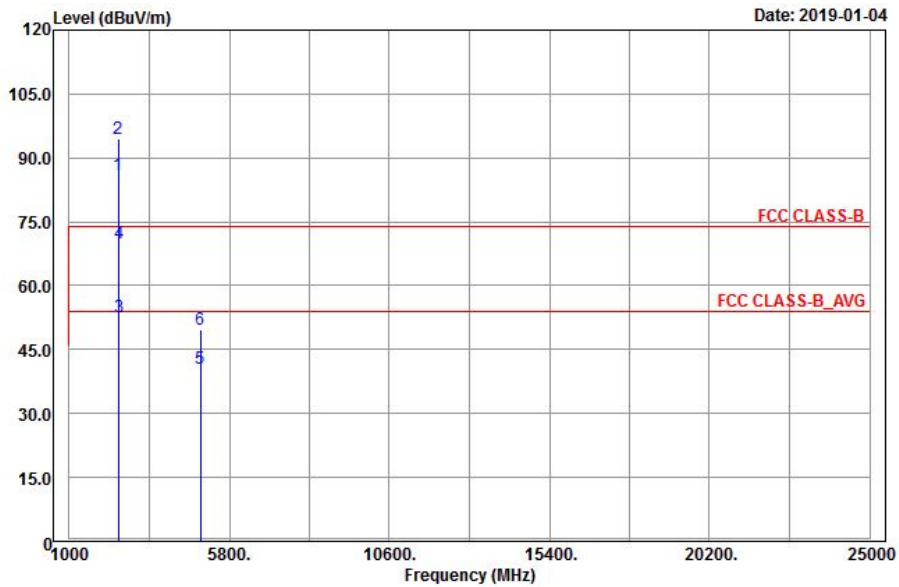

Antennal Polarity & Test Distance: Horizontal at 3 m

Frequency (MHz)	Emission Level (dBuV/m)	Read Level (dBuV)	Limit (dBuV/m)	Margin (dB)	Antenna Factor (dB/m)	Cable Loss (dB)	Preamp Factor (dB)	Antenna Height (cm)	Table Angle (Degree)	Remark
2472	84.37	77.61			31.88	5.5	30.62	100	9	Average
2472	92.47	85.71			31.88	5.5	30.62	100	9	Peak
2483.52	50.89	44.13	54	-3.11	31.88	5.5	30.62	100	9	Average
2483.52	67.4	60.64	74	-6.6	31.88	5.5	30.62	100	9	Peak
4944	38.22	25.66	54	-15.78	33.99	8.29	29.72	166	195	Average
4944	48.45	35.89	74	-25.55	33.99	8.29	29.72	166	195	Peak

Antennal Polarity & Test Distance: Vertical at 3 m

Frequency (MHz)	Emission Level (dBuV/m)	Read Level (dBuV)	Limit (dBuV/m)	Margin (dB)	Antenna Factor (dB/m)	Cable Loss (dB)	Preamp Factor (dB)	Antenna Height (cm)	Table Angle (Degree)	Remark
2472	86.14	79.38			31.88	5.5	30.62	277	360	Average
2472	94.34	87.58			31.88	5.5	30.62	277	360	Peak
2483.52	52.69	45.93	54	-1.31	31.88	5.5	30.62	277	360	Average
2483.52	70.13	63.37	74	-3.87	31.88	5.5	30.62	277	360	Peak
4944	40.46	27.9	54	-13.54	33.99	8.29	29.72	188	175	Average
4944	49.85	37.29	74	-24.15	33.99	8.29	29.72	188	175	Peak

Remarks:

- Emission Level = Read Level + Antenna Factor + Cable Loss - Preamp Factor
Margin value = Emission level – Limit value
- 2472 MHz: Fundamental frequency.
- The emission levels of other frequencies were very low against the limit.

9 kHz ~ 30 MHz Data:

The amplitude of spurious emissions attenuated more than 20 dB below the permissible value is not required to be report.

30 MHz ~ 1 GHz Worst-Case Data:

802.11n (20MHz)

EUT Test Condition		Measurement Detail	
Channel	Channel 13	Frequency Range	30 MHz ~ 1 GHz
Input Power	120 Vac, 60 Hz	Detector Function	Peak (PK) Quasi-peak (QP)
Environmental Conditions	25 deg. C, 65 % RH	Tested By	Karl Lee

Horizontal

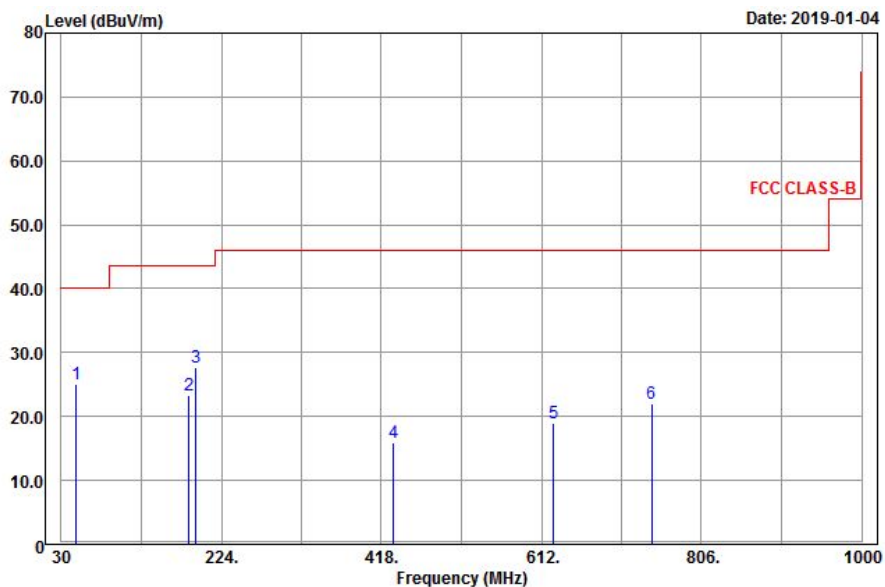

Vertical

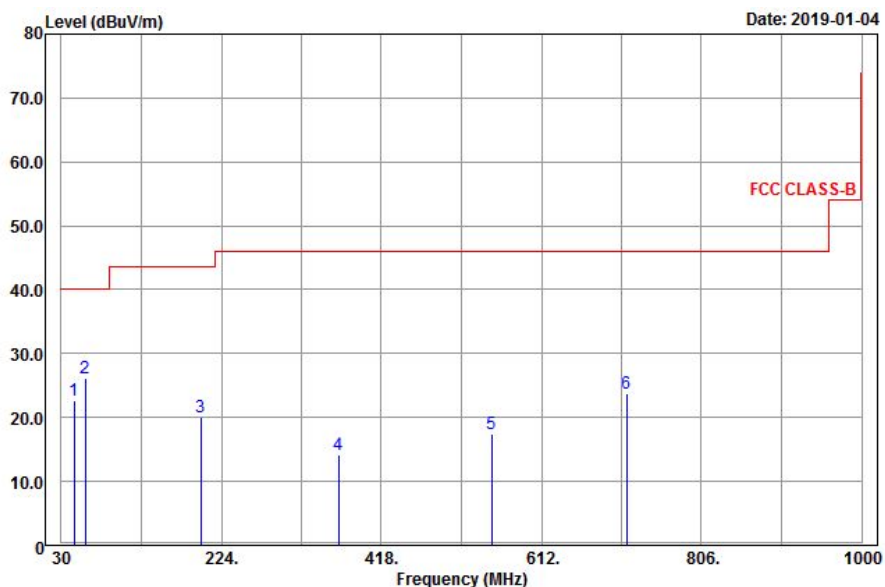

Antennal Polarity & Test Distance: Horizontal at 3 m										
Frequency (MHz)	Emission Level (dBuV/m)	Read Level (dBuV)	Limit (dBuV/m)	Margin (dB)	Antenna Factor (dB/m)	Cable Loss (dB)	Preamp Factor (dB)	Antenna Height (cm)	Table Angle (Degree)	Remark
48.09	25.1	41.86	40	-14.9	14.56	0.9	32.22	166	142	Peak
184.98	23.41	43.84	43.5	-20.09	10.2	1.61	32.24	157	185	Peak
193.62	27.72	47.5	43.5	-15.78	10.88	1.61	32.27	144	187	Peak
433	15.93	30.26	46	-30.07	15.35	2.49	32.17	125	159	Peak
626.9	19	30.06	46	-27	18.18	2.93	32.17	135	187	Peak
745.9	22	31.15	46	-24	19.77	3.22	32.14	155	188	Peak
Antennal Polarity & Test Distance: Vertical at 3 m										
Frequency (MHz)	Emission Level (dBuV/m)	Read Level (dBuV)	Limit (dBuV/m)	Margin (dB)	Antenna Factor (dB/m)	Cable Loss (dB)	Preamp Factor (dB)	Antenna Height (cm)	Table Angle (Degree)	Remark
45.39	22.77	39.68	40	-17.23	14.41	0.9	32.22	129	225	Peak
59.43	26.12	43.93	40	-13.88	13.52	0.9	32.23	155	32	Peak
199.29	20.1	39.67	43.5	-23.4	11.08	1.65	32.3	167	142	Peak
365.8	14.2	29.64	46	-31.8	14.42	2.26	32.12	185	177	Peak
551.3	17.34	29.68	46	-28.66	17.1	2.76	32.2	122	156	Peak
715.1	23.69	33.24	46	-22.31	19.44	3.11	32.1	169	168	Peak

Remarks:

- Emission Level = Read Level + Antenna Factor + Cable Loss - Preamp Factor
Margin value = Emission level – Limit value.
- The emission levels of other frequencies were very low against the limit.

5 Pictures of Test Arrangements

Please refer to the attached file (Test Setup Photo).

Annex A- Band-edge measurement

802.11b

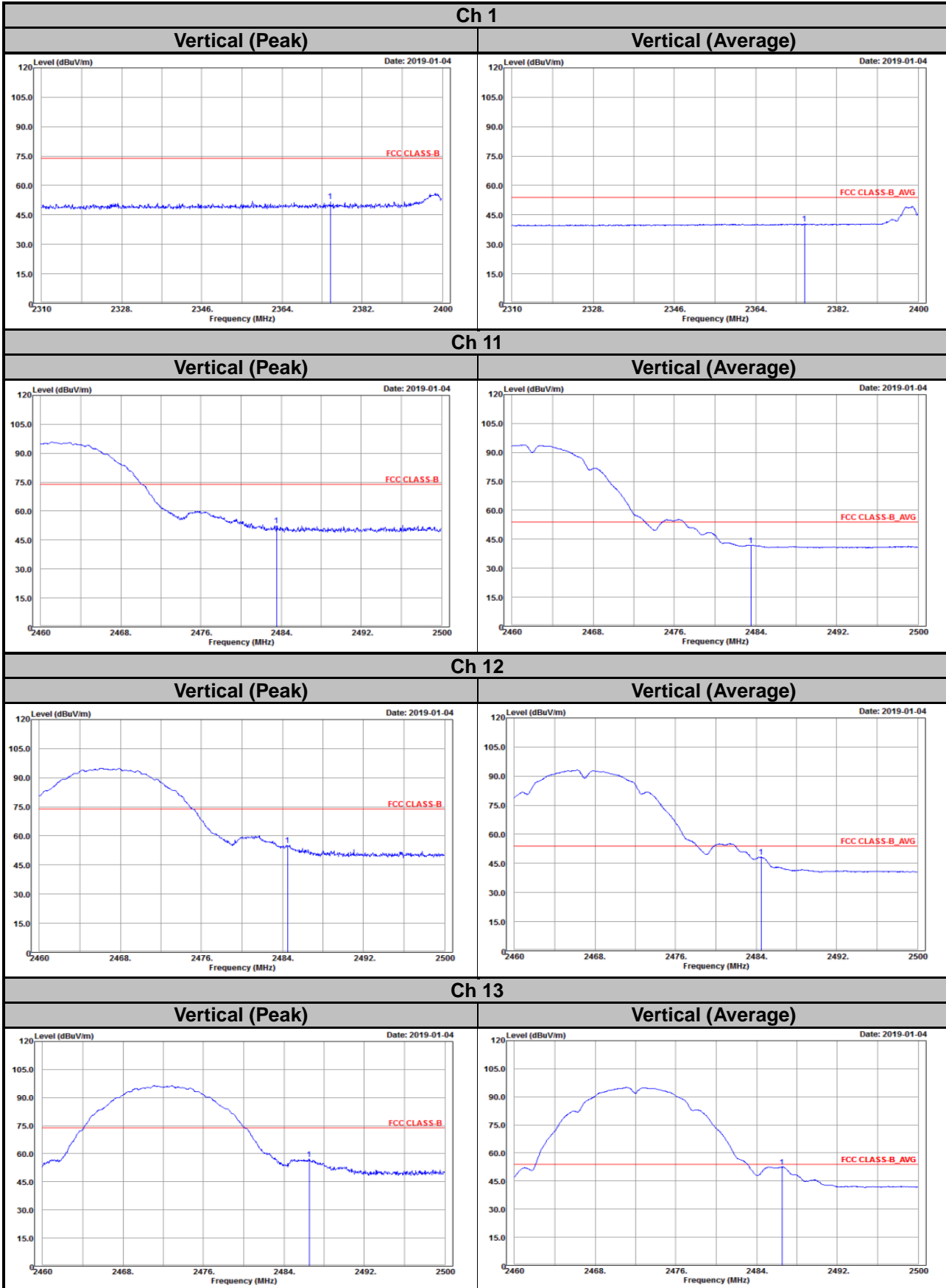

802.11g

Ch 1

Horizontal (Peak)

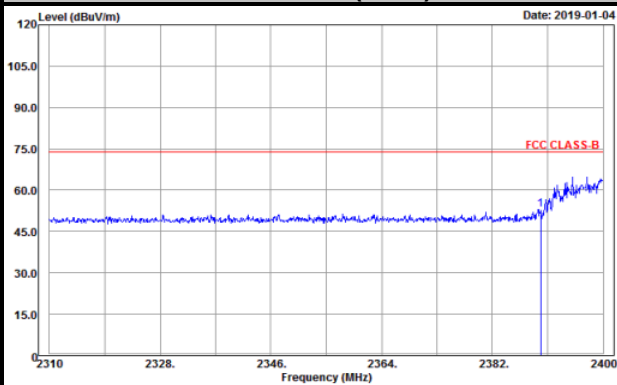

Horizontal (Average)

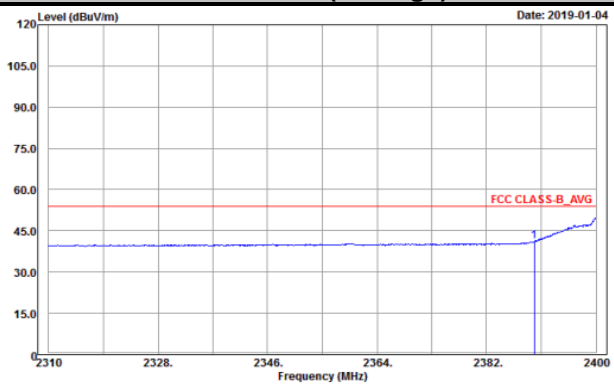

Ch 11

Vertical (Peak)

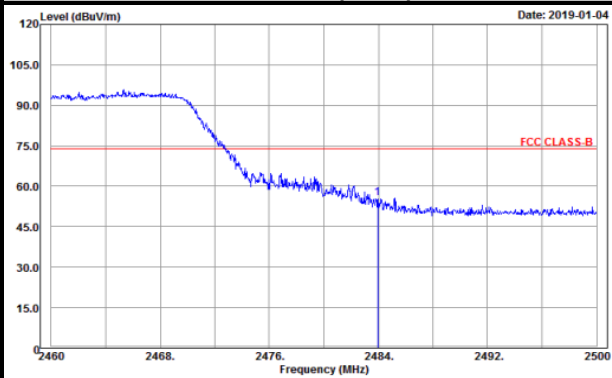

Vertical (Average)

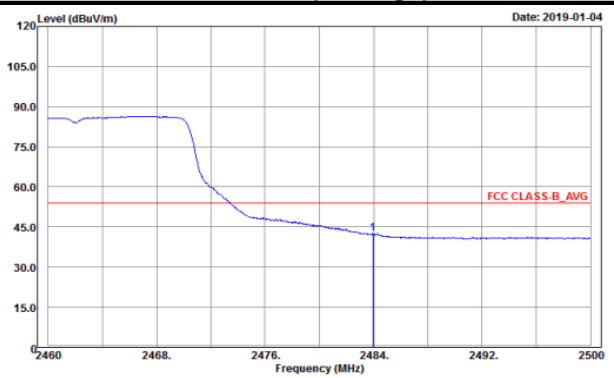

Ch 12

Vertical (Peak)

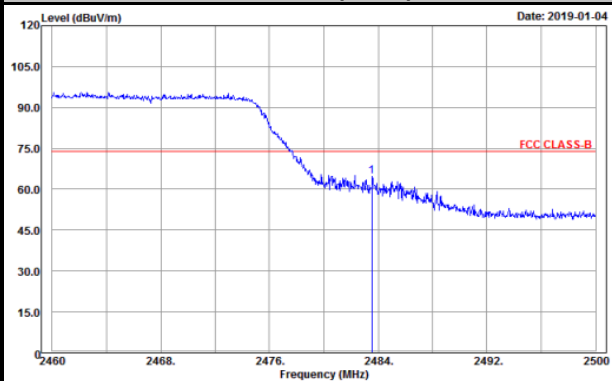

Vertical (Average)

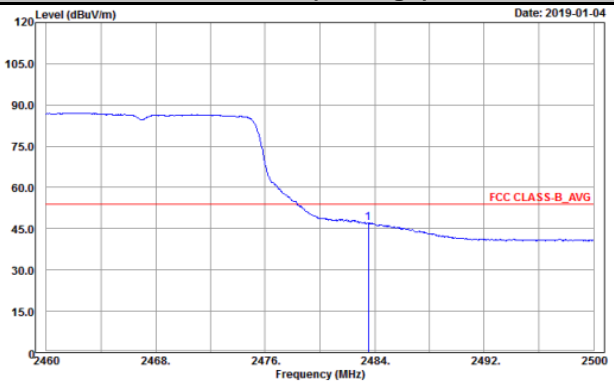

Ch 13

Vertical (Peak)

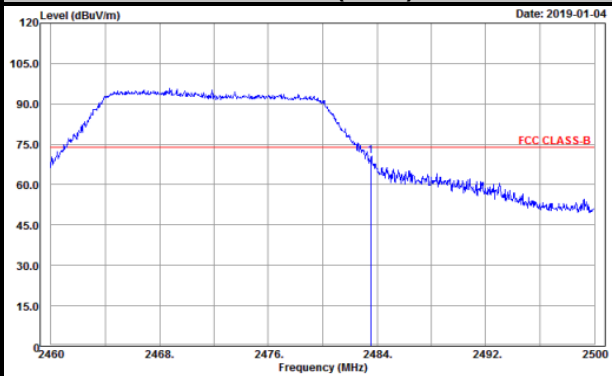

Vertical (Average)

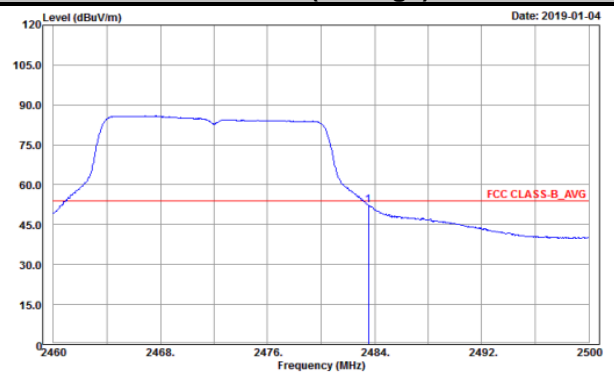

802.11n (HT20)

Ch 1

Vertical (Peak)

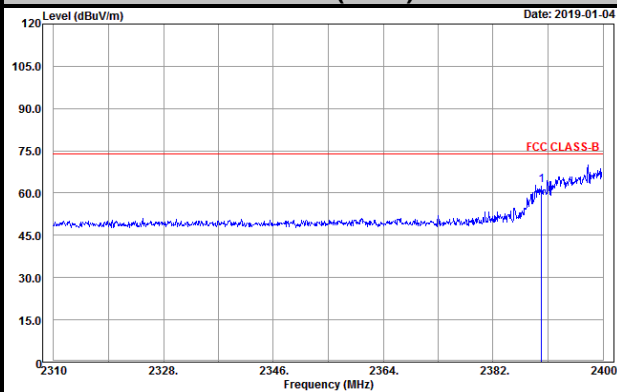

Vertical (Average)

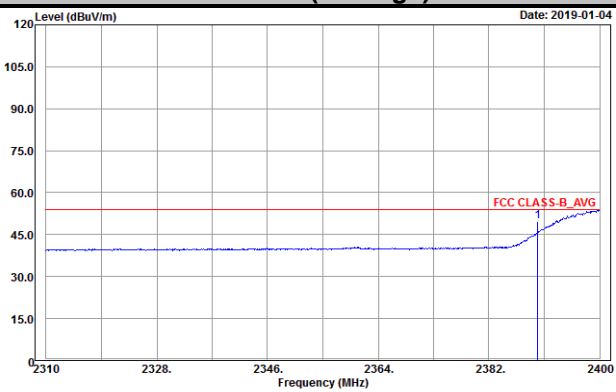

Ch 11

Vertical (Peak)

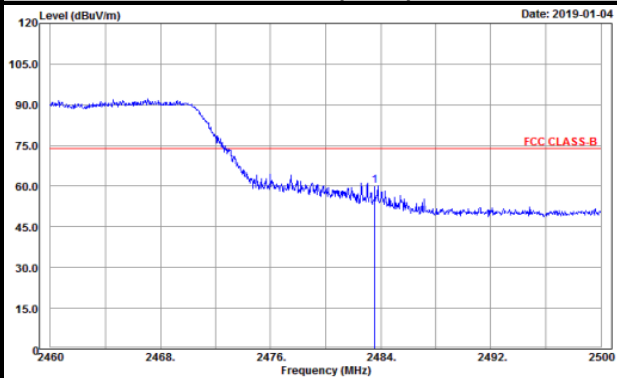

Vertical (Average)

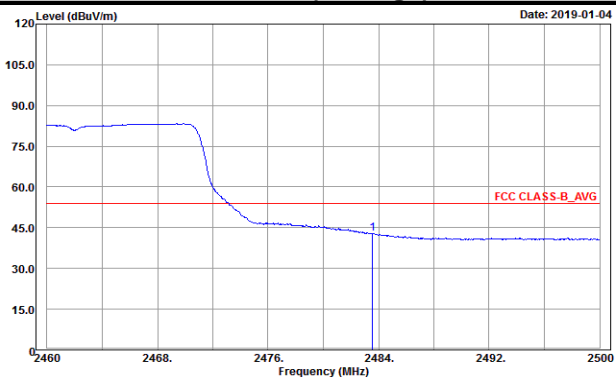

Ch 12

Vertical (Peak)

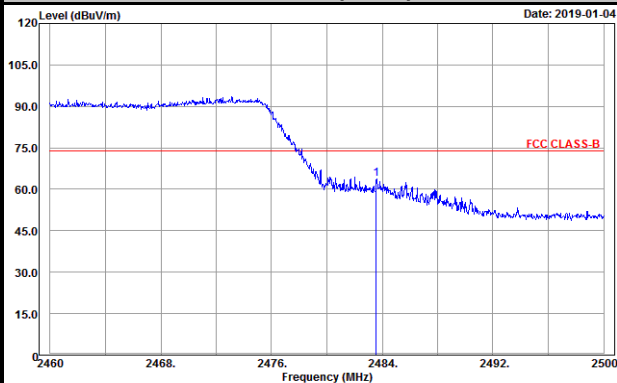

Vertical (Average)

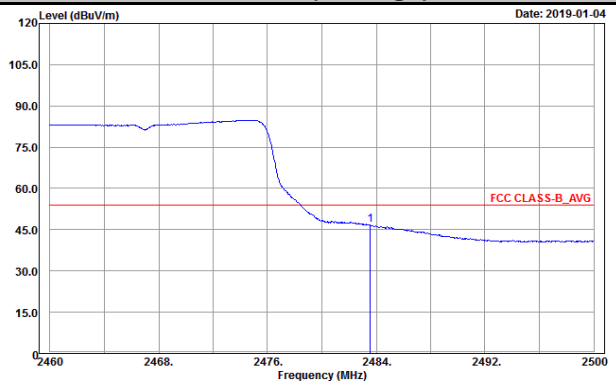

Ch 13

Vertical (Peak)

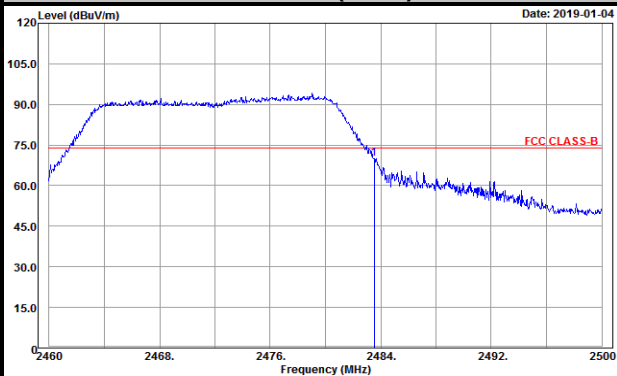

Vertical (Average)

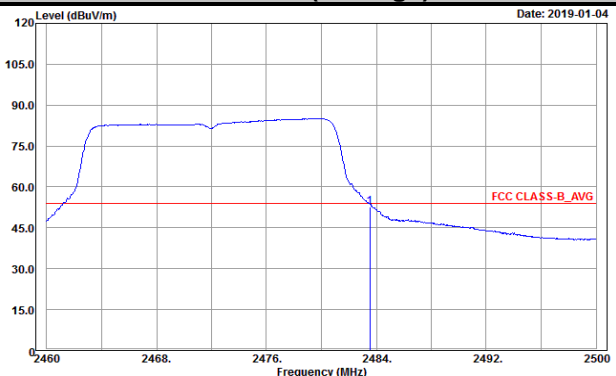

Appendix – Information on the Testing Laboratories

We, Bureau Veritas Consumer Products Services (H.K.) Ltd., Taoyuan Branch, were founded in 1988 to provide our best service in EMC, Radio, Telecom and Safety consultation. Our laboratories are FCC recognized accredited test firms and accredited according to ISO/IEC 17025.

If you have any comments, please feel free to contact us at the following:

Linko EMC/RF Lab

Tel: 886-2-26052180

Fax: 886-2-26051924

Hsin Chu EMC/RF/Telecom Lab

Tel: 886-3-6668565

Fax: 886-3-6668323

Hwa Ya EMC/RF/Safety Lab

Tel: 886-3-3183232

Fax: 886-3-3270892

Email: service.adt@tw.bureauveritas.com

Web Site: www.bureauveritas-adt.com

The address and road map of all our labs can be found in our web site also.

--- END ---