

## FCC Test Report

**Report No.:** RF180621C33

**FCC ID:** UK7-DW9

**Test Model:** DW9F1, DW9F2

**Received Date:** Jun. 21, 2018

**Test Date:** Jul. 21, 2018 ~ Aug. 21, 2018

**Issued Date:** Aug. 30, 2018

**Applicant:** Fossil Group, Inc.

**Address:** 901 S. Central Expressway, Richardson, TX 75080, USA

**Issued By:** Bureau Veritas Consumer Products Services (H.K.) Ltd., Taoyuan Branch

**Lab Address:** No. 47-2, 14th Ling, Chia Pau Vil., Lin Kou Dist., New Taipei City, Taiwan ( R.O.C )

**Test Location:** No.19, Hwa Ya 2nd Rd., Wen Hwa Vil., Kwei Shan Dist., Taoyuan City 33383, Taiwan, R.O.C.

**FCC Registration /  
Designation Number:** 788550 / TW0003



This report is for your exclusive use. Any copying or replication of this report to or for any other person or entity, or use of our name or trademark, is permitted only with our prior written permission. This report sets forth our findings solely with respect to the test samples identified herein. The results set forth in this report are not indicative or representative of the quality or characteristics of the lot from which a test sample was taken or any similar or identical product unless specifically and expressly noted. Our report includes all of the tests requested by you and the results thereof based upon the information that you provided to us. You have 60 days from date of issuance of this report to notify us of any material error or omission caused by our negligence, provided, however, that such notice shall be in writing and shall specifically address the issue you wish to raise. A failure to raise such issue within the prescribed time shall constitute your unqualified acceptance of the completeness of this report, the tests conducted and the correctness of the report contents. Unless specific mention, the uncertainty of measurement has been explicitly taken into account to declare the compliance or non-compliance to the specification. The report must not be used by the client to claim product certification, approval, or endorsement by TAF or any government agencies.

## Table of Contents

<b>Release Control Record</b> .....	<b>6</b>
<b>1 Certificate of Conformity</b> .....	<b>7</b>
<b>2 Summary of Test Results</b> .....	<b>8</b>
2.1 Measurement Uncertainty .....	10
2.2 Modification Record .....	10
<b>3 General Information</b> .....	<b>11</b>
3.1 General Description of EUT .....	11
3.2 Description of Test Modes .....	12
3.2.1 Test Mode Applicability and Tested Channel Detail .....	14
3.3 Duty Cycle of Test Signal .....	20
3.4 Description of Support Units .....	22
3.4.1 Configuration of System under Test .....	22
3.5 General Description of Applied Standards .....	23
<b>4 Test Types and Results</b> .....	<b>24</b>
<Bluetooth EDR> .....	24
4.1 Radiated Emission and Bandedge Measurement .....	24
4.1.1 Limits of Radiated Emission and Bandedge Measurement .....	24
4.1.2 Test Instruments .....	25
4.1.3 Test Procedures .....	27
4.1.4 Deviation from Test Standard .....	28
4.1.5 Test Setup .....	28
4.1.6 EUT Operating Conditions .....	29
4.1.7 Test Results .....	30
4.2 Conducted Emission Measurement .....	58
4.2.1 Limits of Conducted Emission Measurement .....	58
4.2.2 Test Instruments .....	58
4.2.3 Test Procedures .....	59
4.2.4 Deviation from Test Standard .....	59
4.2.5 Test Setup .....	59
4.2.6 EUT Operating Condition .....	59
4.2.7 Test Results .....	60
4.3 Number of Hopping Frequency Used .....	64
4.3.1 Limits of Hopping Frequency Used Measurement .....	64
4.3.2 Test Setup .....	64
4.3.3 Test Instruments .....	64
4.3.4 Test Procedure .....	64
4.3.5 Deviation from Test Standard .....	64
4.3.6 Test Results .....	65
4.4 Dwell Time on Each Channel .....	66
4.4.1 Limits of Dwell Time on Each Channel Measurement .....	66
4.4.2 Test Setup .....	66
4.4.3 Test Instruments .....	66
4.4.4 Test Procedures .....	66
4.4.5 Deviation from Test Standard .....	66
4.4.6 Test Results .....	67
4.5 Channel Bandwidth .....	70
4.5.1 Limits of Channel Bandwidth Measurement .....	70
4.5.2 Test Setup .....	70
4.5.3 Test Instruments .....	70
4.5.4 Test Procedure .....	70
4.5.5 Deviation from Test Standard .....	70
4.5.6 EUT Operating Condition .....	70
4.5.7 Test Results .....	71

4.6	Occupied Bandwidth Measurement.....	72
4.6.1	Test Setup.....	72
4.6.2	Test Instruments.....	72
4.6.3	Test Procedure.....	72
4.6.4	Deviation from Test Standard.....	72
4.6.5	EUT Operating Conditions.....	72
4.6.6	Test Results.....	73
4.7	Hopping Channel Separation.....	74
4.7.1	Limits of Hopping Channel Separation Measurement.....	74
4.7.2	Test Setup.....	74
4.7.3	Test Instruments.....	74
4.7.4	Test Procedure.....	74
4.7.5	Deviation from Test Standard.....	74
4.7.6	Test Results.....	75
4.8	Maximum Output Power.....	76
4.8.1	Limits of Maximum Output Power Measurement.....	76
4.8.2	Test Setup.....	76
4.8.3	Test Instruments.....	76
4.8.4	Test Procedure.....	76
4.8.5	Deviation from Test Standard.....	76
4.8.6	EUT Operating Condition.....	76
4.8.7	Test Results.....	77
4.9	Conducted Out of Band Emission Measurement.....	78
4.9.1	Limits Of Conducted Out of Band Emission Measurement.....	78
4.9.2	Test Instruments.....	78
4.9.3	Test Procedure.....	78
4.9.4	Deviation from Test Standard.....	78
4.9.5	EUT Operating Condition.....	78
4.9.6	Test Results.....	78
	<Bluetooth LE>.....	83
4.10	Radiated Emission and Bandedge Measurement.....	83
4.10.1	Limits of Radiated Emission and Bandedge Measurement.....	83
4.10.2	Test Instruments.....	83
4.10.3	Test Procedures.....	84
4.10.4	Deviation from Test Standard.....	85
4.10.5	Test Set Up.....	85
4.10.6	EUT Operating Conditions.....	86
4.10.7	Test Results.....	87
4.11	Conducted Emission Measurement.....	103
4.11.1	Limits of Conducted Emission Measurement.....	103
4.11.2	Test Instruments.....	103
4.11.3	Test Procedures.....	103
4.11.4	Deviation from Test Standard.....	104
4.11.5	Test Setup.....	104
4.11.6	EUT Operating Conditions.....	104
4.11.7	Test Results.....	105
4.12	6 dB Bandwidth Measurement.....	109
4.12.1	Limits of 6 dB Bandwidth Measurement.....	109
4.12.2	Test Setup.....	109
4.12.3	Test Instruments.....	109
4.12.4	Test Procedure.....	109
4.12.5	Deviation from Test Standard.....	109
4.12.6	EUT Operating Conditions.....	109
4.12.7	Test Results.....	110
4.13	Occupied Bandwidth Measurement.....	111
4.13.1	Test Setup.....	111
4.13.2	Test Instruments.....	111
4.13.3	Test Procedure.....	111

4.13.4	Deviation from Test Standard .....	111
4.13.5	EUT Operating Conditions .....	111
4.13.6	Test Results .....	112
4.14	Conducted Output Power Measurement .....	113
4.14.1	Limits of Conducted Output Power Measurement.....	113
4.14.2	Test Setup .....	113
4.14.3	Test Instruments .....	113
4.14.4	Test Procedures.....	113
4.14.5	Deviation from Test Standard .....	113
4.14.6	EUT Operating Conditions.....	113
4.14.7	Test Results .....	113
4.15	Power Spectral Density Measurement .....	114
4.15.1	Limits of Power Spectral Density Measurement.....	114
4.15.2	Test Setup .....	114
4.15.3	Test Instruments .....	114
4.15.4	Test Procedure .....	114
4.15.5	Deviation from Test Standard .....	114
4.15.6	EUT Operating Condition .....	114
4.15.7	Test Results .....	115
4.16	Conducted Out of Band Emission Measurement .....	116
4.16.1	Limits of Conducted Out of Band Emission Measurement.....	116
4.16.2	Test Setup .....	116
4.16.3	Test Instruments .....	116
4.16.4	Test Procedure .....	116
4.16.5	Deviation from Test Standard .....	116
4.16.6	EUT Operating Condition .....	116
4.16.7	Test Results .....	117
<WLAN>	.....	119
4.17	Radiated Emission and Bandedge Measurement .....	119
4.17.1	Limits of Radiated Emission and Bandedge Measurement .....	119
4.17.2	Test Instruments .....	119
4.17.3	Test Procedures.....	120
4.17.4	Deviation from Test Standard .....	121
4.17.5	Test Set Up .....	121
4.17.6	EUT Operating Conditions.....	122
4.17.7	Test Results .....	123
4.18	Conducted Emission Measurement.....	187
4.18.1	Limits of Conducted Emission Measurement .....	187
4.18.2	Test Instruments .....	187
4.18.3	Test Procedures.....	187
4.18.4	Deviation from Test Standard .....	187
4.18.5	Test Setup .....	188
4.18.6	EUT Operating Conditions.....	188
4.18.7	Test Results .....	189
4.19	6 dB Bandwidth Measurement.....	193
4.19.1	Limits of 6 dB Bandwidth Measurement.....	193
4.19.2	Test Setup .....	193
4.19.3	Test Instruments .....	193
4.19.4	Test Procedure .....	193
4.19.5	Deviation from Test Standard .....	193
4.19.6	EUT Operating Conditions.....	193
4.19.7	Test Results .....	194
4.20	Occupied Bandwidth Measurement.....	196
4.20.1	Test Setup .....	196
4.20.2	Test Instruments .....	196
4.20.3	Test Procedure .....	196
4.20.4	Deviation from Test Standard .....	196
4.20.5	EUT Operating Conditions.....	196

4.20.6	Test Results .....	197
4.21	Conducted Output Power Measurement .....	199
4.21.1	Limits of Conducted Output Power Measurement.....	199
4.21.2	Test Setup.....	199
4.21.3	Test Instruments .....	199
4.21.4	Test Procedures.....	199
4.21.5	Deviation from Test Standard .....	199
4.21.6	EUT Operating Conditions.....	199
4.21.7	Test Results .....	200
4.22	Power Spectral Density Measurement .....	201
4.22.1	Limits of Power Spectral Density Measurement.....	201
4.22.2	Test Setup.....	201
4.22.3	Test Instruments .....	201
4.22.4	Test Procedure .....	201
4.22.5	Deviation from Test Standard .....	201
4.22.6	EUT Operating Condition .....	201
4.22.7	Test Results .....	202
4.23	Conducted Out of Band Emission Measurement .....	204
4.23.1	Limits of Conducted Out of Band Emission Measurement.....	204
4.23.2	Test Setup.....	204
4.23.3	Test Instruments .....	204
4.23.4	Test Procedure .....	204
4.23.5	Deviation from Test Standard .....	204
4.23.6	EUT Operating Condition .....	204
4.23.7	Test Results .....	205
<b>5</b>	<b>Pictures of Test Arrangements.....</b>	<b>211</b>
	<b>Appendix – Information on the Testing Laboratories .....</b>	<b>212</b>

### Release Control Record

Issue No.	Description	Date Issued
RF180621C33	Original Release	Aug. 30, 2018

## 1 Certificate of Conformity

**Product:** Smart Watch

**Sample Status:** Identical Prototype

**Applicant:** Fossil Group, Inc.

**Test Date:** Jul. 21, 2018 ~ Aug. 21, 2018

**Standards:** 47 CFR FCC Part 15, Subpart C (Section 15.247)  
ANSI C63.10:2013

The above equipment has been tested by **Bureau Veritas Consumer Products Services (H.K.) Ltd., Taoyuan Branch**, and found compliance with the requirement of the above standards. The test record, data evaluation & Equipment Under Test (EUT) configurations represented herein are true and accurate accounts of the measurements of the sample's RF characteristics under the conditions specified in this report.

**Prepared by :** Rona Chen, **Date:** Aug. 30, 2018  
Rona Chen / Specialist

**Approved by :** Dylan Chiou, **Date:** Aug. 30, 2018  
Dylan Chiou / Project Engineer

## 2 Summary of Test Results

### <Bluetooth EDR>

47 CFR FCC Part 15, Subpart C (Section 15.247)			
FCC Clause	Test Item	Result	Remarks
15.207	AC Power Conducted Emission	Pass	Meet the requirement of limit. Minimum passing margin is -19.34 dB at 0.59965 MHz.
15.247(a)(1)(iii)	Number of Hopping Frequency Used	Pass	Meet the requirement of limit.
15.247(a)(1)(iii)	Dwell Time on Each Channel	Pass	Meet the requirement of limit.
15.247(a)(1)	1. Hopping Channel Separation 2. Spectrum Bandwidth of a Frequency Hopping Sequence Spread Spectrum System	Pass	Meet the requirement of limit.
15.247(b)	Maximum Peak Output Power	Pass	Meet the requirement of limit.
---	Occupied Bandwidth Measurement	Pass	Reference only
15.205 & 209	Radiated Emissions	Pass	Meet the requirement of limit. Minimum passing margin is -5.44 dB at 859.35 MHz.
15.247(d)	Band Edge Measurement	Pass	Meet the requirement of limit.
15.247(d)	Antenna Port Emission	Pass	Meet the requirement of limit.
15.203	Antenna Requirement	Pass	No antenna connector is used.

**Note:** If The Frequency Hopping System operating in 2400-2483.5 MHz band and the output power less than 125 mW. The hopping channel carrier frequencies separated by a minimum of 25 kHz or two-thirds of the 20 dB bandwidth of hopping channel whichever is greater.



<Bluetooth LE>

47 CFR FCC Part 15, Subpart C (Section 15.247)			
FCC Clause	Test Item	Result	Remarks
15.207	AC Power Conducted Emission	Pass	Meet the requirement of limit. Minimum passing margin is -19.79 dB at 0.60356 MHz.
15.205 & 209	Radiated Emissions	Pass	Meet the requirement of limit. Minimum passing margin is -4.99 dB at 872.93 MHz.
15.247(d)	Band Edge Measurement	Pass	Meet the requirement of limit.
15.247(d)	Antenna Port Emission	Pass	Meet the requirement of limit.
15.247(a)(2)	6 dB Bandwidth	Pass	Meet the requirement of limit.
---	Occupied Bandwidth Measurement	Pass	Reference only
15.247(b)	Conducted Power	Pass	Meet the requirement of limit.
15.247(e)	Power Spectral Density	Pass	Meet the requirement of limit.
15.203	Antenna Requirement	Pass	No antenna connector is used.

<WLAN>

47 CFR FCC Part 15, Subpart C (Section 15.247)			
FCC Clause	Test Item	Result	Remarks
15.207	AC Power Conducted Emission	Pass	Meet the requirement of limit. Minimum passing margin is -18.62 dB at 0.59183 MHz.
15.205 / 15.209 / 15.247(d)	Radiated Emissions and Band Edge Measurement	Pass	Meet the requirement of limit. Minimum passing margin is -0.44 dB at 2483.6 MHz.
15.247(d)	Antenna Port Emission	Pass	Meet the requirement of limit.
15.247(a)(2)	6 dB Bandwidth	Pass	Meet the requirement of limit.
---	Occupied Bandwidth Measurement	Pass	Reference only
15.247(b)	Conducted power	Pass	Meet the requirement of limit.
15.247(e)	Power Spectral Density	Pass	Meet the requirement of limit.
15.203	Antenna Requirement	Pass	No antenna connector is used.

## 2.1 Measurement Uncertainty

Where relevant, the following measurement uncertainty levels have been estimated for tests performed on the EUT as specified in CISPR 16-4-2:

Measurement	Frequency	Expanded Uncertainty (k=2) (±)
Conducted Emissions at mains ports	150 kHz ~ 30 MHz	2.44 dB
Radiated Emissions up to 1 GHz	9 kHz ~ 30 MHz	2.855 dB
	30 MHz ~ 200 MHz	2.93 dB
	200 MHz ~ 1000 MHz	2.95 dB
Radiated Emissions above 1 GHz	1 GHz ~ 18 GHz	2.26 dB
	18 GHz ~ 40 GHz	1.94 dB

## 2.2 Modification Record

There were no modifications required for compliance.

### 3 General Information

#### 3.1 General Description of EUT

<b>Product</b>	Smart Watch	
<b>Test Model</b>	DW9F1, DW9F2	
<b>Status of EUT</b>	Identical Prototype	
<b>Power Supply Rating</b>	5.0 Vdc (Host equipment or Charging Dock or Adapter) 3.85 Vdc (Battery)	
<b>Modulation Type</b>	Bluetooth EDR	GFSK, $\pi/4$ -DQPSK, 8DPSK
	Bluetooth LE	GFSK
	WLAN	CCK, DQPSK, DBPSK for DSSS 64QAM, 16QAM, QPSK, BPSK for OFDM
<b>Transfer Rate</b>	Bluetooth EDR	1/2/3 Mbps
	Bluetooth LE	1 Mbps
	WLAN	802.11b: 11.0 / 5.5 / 2.0 / 1.0 Mbps 802.11g: 54.0 / 48.0 / 36.0 / 24.0 / 18.0 / 12.0 / 9.0 / 6.0 Mbps 802.11n: up to 72.2 Mbps
<b>Operating Frequency</b>	Bluetooth EDR	2402 ~ 2480 MHz
	Bluetooth LE	2402 ~ 2480 MHz
	WLAN	2412 ~ 2472 MHz
<b>Number of Channel</b>	Bluetooth EDR	79
	Bluetooth LE	40
	WLAN	13 for 802.11b, 802.11g, 802.11n (HT20)
<b>Output Power</b>	Bluetooth EDR	13.366 mW
	Bluetooth LE	1.578 mW
	WLAN	93.541 mW
<b>Antenna Type</b>	Loop antenna	
<b>Antenna Connector</b>	N/A	
<b>Accessory Device</b>	Refer to Note as below	
<b>Data Cable Supplied</b>	Refer to Note as below	

Note:

1. All models are listed as below.

Sample	Model	Antenna Gain (dBi)		Description
		2.4G / BT	GPS	
1	DW9F1	-9.7	-7.15	The samples are different in the appearance and antenna only.
2	DW9F2	-8.26	-5.26	

2. The EUT EUT provides one completed transmitter and one receiver.

Modulation Mode	Tx Function
802.11b	1TX
802.11g	1TX
802.11n (HT20)	1TX

3. The EUT's accessories list refers to EUT Photo.pdf.
4. The above EUT information is declared by manufacturer and for more detailed features description, please refers to the manufacturer's specifications or User's Manual.

### 3.2 Description of Test Modes

#### <Bluetooth EDR>

79 channels are provided to this EUT:

Channel	Freq. (MHz)	Channel	Freq. (MHz)	Channel	Freq. (MHz)	Channel	Freq. (MHz)
0	2402	20	2422	40	2442	60	2462
1	2403	21	2423	41	2443	61	2463
2	2404	22	2424	42	2444	62	2464
3	2405	23	2425	43	2445	63	2465
4	2406	24	2426	44	2446	64	2466
5	2407	25	2427	45	2447	65	2467
6	2408	26	2428	46	2448	66	2468
7	2409	27	2429	47	2449	67	2469
8	2410	28	2430	48	2450	68	2470
9	2411	29	2431	49	2451	69	2471
10	2412	30	2432	50	2452	70	2472
11	2413	31	2433	51	2453	71	2473
12	2414	32	2434	52	2454	72	2474
13	2415	33	2435	53	2455	73	2475
14	2416	34	2436	54	2456	74	2476
15	2417	35	2437	55	2457	75	2477
16	2418	36	2438	56	2458	76	2478
17	2419	37	2439	57	2459	77	2479
18	2420	38	2440	58	2460	78	2480
19	2421	39	2441	59	2461		

#### <Bluetooth LE>

40 channels are provided to this EUT:

Channel	Freq. (MHz)	Channel	Freq. (MHz)	Channel	Freq. (MHz)	Channel	Freq. (MHz)
0	2402	10	2422	20	2442	30	2462
1	2404	11	2424	21	2444	31	2464
2	2406	12	2426	22	2446	32	2466
3	2408	13	2428	23	2448	33	2468
4	2410	14	2430	24	2450	34	2470
5	2412	15	2432	25	2452	35	2472
6	2414	16	2434	26	2454	36	2474
7	2416	17	2436	27	2456	37	2476
8	2418	18	2438	28	2458	38	2478
9	2420	19	2440	29	2460	39	2480

**<WLAN>**

13 channels are provided for 802.11b, 802.11g and 802.11n (HT20):

Channel	Frequency (MHz)	Channel	Frequency (MHz)
1	2412	8	2447
2	2417	9	2452
3	2422	10	2457
4	2427	11	2462
5	2432	12	2467
6	2437	13	2472
7	2442		

### 3.2.1 Test Mode Applicability and Tested Channel Detail

#### <Bluetooth EDR>

EUT Configure Mode	Applicable To				Description
	RE $\geq$ 1G	RE<1G	PLC	APCM	
A	√	√	√	√	Sample 1
B	√	√	√	-	Sample 2

Where **RE $\geq$ 1G**: Radiated Emission above 1 GHz      **RE<1G**: Radiated Emission below 1 GHz  
**PLC**: Power Line Conducted Emission      **APCM**: Antenna Port Conducted Measurement

**Note:**

1. The EUT had been pre-tested on the positioned of each 3 axis. The worst case was found when positioned on **Y-plane** for Mode A and **Z-plane** for Mode B.
2. "-" means no effect.

#### **Radiated Emission Test (Above 1 GHz):**

- Pre-Scan has been conducted to determine the worst-case mode from all possible combinations between available modulations, data rates and antenna ports (if EUT with antenna diversity architecture).
- Following channel(s) was (were) selected for the final test as listed below.

EUT Configure Mode	Available Channel	Tested Channel	Modulation Technology	Modulation Type	Packet Type
A, B	0 to 78	0, 39, 78	FHSS	GFSK	DH5
	0 to 78	0, 39, 78	FHSS	8DPSK	3DH5

#### **Radiated Emission Test (Below 1 GHz):**

- Pre-Scan has been conducted to determine the worst-case mode from all possible combinations between available modulations, data rates and antenna ports (if EUT with antenna diversity architecture).
- Following channel(s) was (were) selected for the final test as listed below.

EUT Configure Mode	Available Channel	Tested Channel	Modulation Technology	Modulation Type	Packet Type
A, B	0 to 78	0	FHSS	GFSK	3DH5

#### **Power Line Conducted Emission Test:**

- Pre-Scan has been conducted to determine the worst-case mode from all possible combinations between available modulations, data rates and antenna ports (if EUT with antenna diversity architecture).
- Following channel(s) was (were) selected for the final test as listed below.

EUT Configure Mode	Available Channel	Tested Channel	Modulation Technology	Modulation Type	Packet Type
A, B	0 to 78	0	FHSS	GFSK	3DH5

**Antenna Port Conducted Measurement:**

- This item includes all test value of each mode, but only includes spectrum plot of worst value of each mode.
- Pre-Scan has been conducted to determine the worst-case mode from all possible combinations between available modulations, data rates and antenna ports (if EUT with antenna diversity architecture).
- Following channel(s) was (were) selected for the final test as listed below.

EUT Configure Mode	Available Channel	Tested Channel	Modulation Technology	Modulation Type	Packet Type
A	0 to 78	0, 39, 78	FHSS	GFSK	DH5
	0 to 78	0, 39, 78	FHSS	8DPSK	3DH5

### <Bluetooth LE>

EUT Configure Mode	Applicable To				Description
	RE $\geq$ 1G	RE<1G	PLC	APCM	
A	√	√	√	√	Sample 1
B	√	√	√	-	Sample 2

Where **RE $\geq$ 1G**: Radiated Emission above 1 GHz      **RE<1G**: Radiated Emission below 1 GHz  
**PLC**: Power Line Conducted Emission      **APCM**: Antenna Port Conducted Measurement

**Note:**

1. The EUT had been pre-tested on the positioned of each 3 axis. The worst case was found when positioned on **Y-plane** for Mode A and **Z-plane** for Mode B.
2. "-" means no effect.

#### **Radiated Emission Test (Above 1 GHz):**

- Pre-Scan has been conducted to determine the worst-case mode from all possible combinations between available modulations, data rates and antenna ports (if EUT with antenna diversity architecture).
- Following channel(s) was (were) selected for the final test as listed below.

EUT Configure Mode	Available Channel	Tested Channel	Modulation Type	Data Rate (Mbps)
A, B	0 to 39	0, 19, 39	GFSK	1

#### **Radiated Emission Test (Below 1 GHz):**

- Pre-Scan has been conducted to determine the worst-case mode from all possible combinations between available modulations, data rates and antenna ports (if EUT with antenna diversity architecture).
- Following channel(s) was (were) selected for the final test as listed below.

EUT Configure Mode	Available Channel	Tested Channel	Modulation Type	Data Rate (Mbps)
A	0 to 39	39	GFSK	1
B	0 to 39	0	GFSK	1

#### **Power Line Conducted Emission Test:**

- Pre-Scan has been conducted to determine the worst-case mode from all possible combinations between available modulations, data rates and antenna ports (if EUT with antenna diversity architecture).
- Following channel(s) was (were) selected for the final test as listed below.

EUT Configure Mode	Available Channel	Tested Channel	Modulation Type	Data Rate (Mbps)
A	0 to 39	39	GFSK	1
B	0 to 39	0	GFSK	1



**Antenna Port Conducted Measurement:**

- This item includes all test value of each mode, but only includes spectrum plot of worst value of each mode.
- Pre-Scan has been conducted to determine the worst-case mode from all possible combinations between available modulations, data rates and antenna ports (if EUT with antenna diversity architecture).
- Following channel(s) was (were) selected for the final test as listed below.

EUT Configure Mode	Available Channel	Tested Channel	Modulation Type	Data Rate (Mbps)
A	0 to 39	0, 19, 39	GFSK	1

<WLAN>

EUT Configure Mode	Applicable To				Description
	RE≥1G	RE<1G	PLC	APCM	
A	√	√	√	√	Sample 1
B	√	√	√	-	Sample 2

Where **RE≥1G**: Radiated Emission above 1 GHz      **RE<1G**: Radiated Emission below 1 GHz  
**PLC**: Power Line Conducted Emission      **APCM**: Antenna Port Conducted Measurement

**NOTE:**

1. The EUT had been pre-tested on the positioned of each 3 axis. The worst case was found when positioned on **Z-plane** for Mode A and **Y-plane** for Mode B.
2. "-" means no effect.

**Radiated Emission Test (Above 1 GHz):**

- Pre-Scan has been conducted to determine the worst-case mode from all possible combinations between available modulations, data rates and antenna ports (if EUT with antenna diversity architecture).
- Following channel(s) was (were) selected for the final test as listed below.

EUT Configure Mode	Mode	Available Channel	Tested Channel	Modulation Technology	Modulation Type	Data Rate (Mbps)
-	802.11b	1 to 13	1, 6, 11, 12, 13	DSSS	DBPSK	1.0
-	802.11g	1 to 13	1, 6, 11, 12, 13	OFDM	BPSK	6.0
-	802.11n (HT20)	1 to 13	1, 6, 11, 12, 13	OFDM	BPSK	6.5

**Radiated Emission Test (Below 1 GHz):**

- Pre-Scan has been conducted to determine the worst-case mode from all possible combinations between available modulations, data rates and antenna ports (if EUT with antenna diversity architecture).
- Following channel(s) was (were) selected for the final test as listed below.

EUT Configure Mode	Mode	Available Channel	Tested Channel	Modulation Technology	Modulation Type	Data Rate (Mbps)
A, B	802.11n (HT20)	1 to 13	13	OFDM	BPSK	6.5

**Power Line Conducted Emission Test:**

- Pre-Scan has been conducted to determine the worst-case mode from all possible combinations between available modulations, data rates and antenna ports (if EUT with antenna diversity architecture).
- Following channel(s) was (were) selected for the final test as listed below.

EUT Configure Mode	Mode	Available Channel	Tested Channel	Modulation Technology	Modulation Type	Data Rate (Mbps)
A, B	802.11n (HT20)	1 to 13	13	OFDM	BPSK	6.5

### Antenna Port Conducted Measurement:

- This item includes all test value of each mode, but only includes spectrum plot of worst value of each mode.
- Pre-Scan has been conducted to determine the worst-case mode from all possible combinations between available modulations, data rates and antenna ports (if EUT with antenna diversity architecture).
- Following channel(s) was (were) selected for the final test as listed below.

EUT Configure Mode	Mode	Available Channel	Tested Channel	Modulation Technology	Modulation Type	Data Rate (Mbps)
-	802.11b	1 to 13	1, 6, 11, 12, 13	DSSS	DBPSK	1.0
-	802.11g	1 to 13	1, 6, 11, 12, 13	OFDM	BPSK	6.0
-	802.11n (HT20)	1 to 13	1, 6, 11, 12, 13	OFDM	BPSK	6.5

### Test Condition:

Applicable To	Environmental Conditions	Input Power	Tested by
RE $\geq$ 1G	25 deg. C, 65 % RH	120 Vac, 60 Hz	Thomas Wei
RE $<$ 1G	25 deg. C, 65 % RH	120 Vac, 60 Hz	Thomas Wei
PLC	25 deg. C, 65 % RH	120 Vac, 60 Hz	Jisyong Wang
APCM	25 deg. C, 65 % RH	3.8 Vdc	Frank Chiu

### 3.3 Duty Cycle of Test Signal

#### <Bluetooth EDR>

Duty cycle =  $2.882/3.752 = 0.768$ , Duty factor =  $10 * \log(1/0.768) = 1.15$

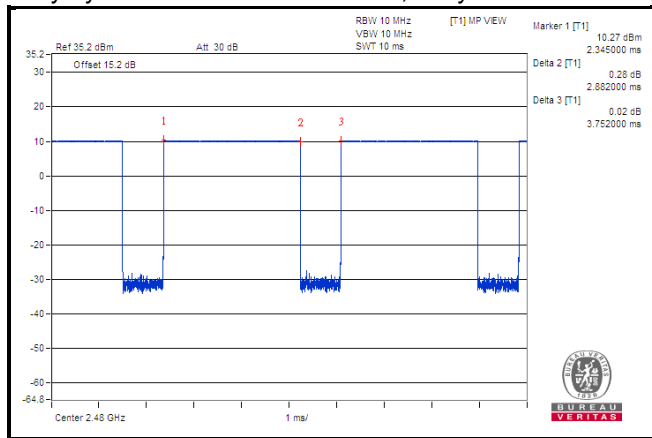

#### <Bluetooth LE>

Duty cycle =  $0.377/0.627 = 0.601$ , Duty factor =  $10 * \log(1/0.601) = 2.21$

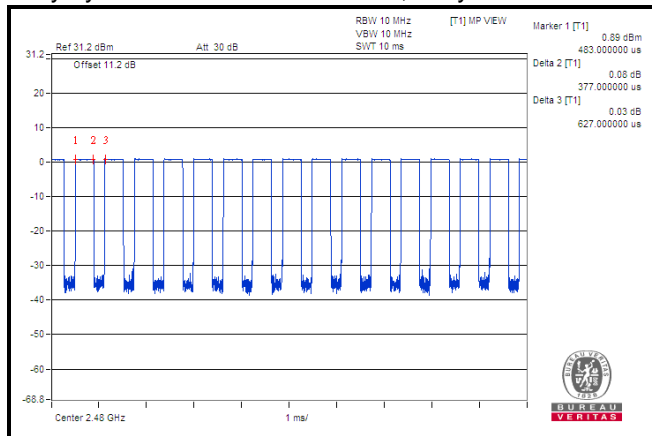

<WLAN>

**802.11b:** Duty cycle =  $8.220/8.430 = 0.975$ , Duty factor =  $10 * \log( 1/0.975) = 0.11$

**802.11g:** Duty cycle =  $1.358/1.565 = 0.868$ , Duty factor =  $10 * \log( 1/0.868) = 0.62$

**802.11n (HT20):** Duty cycle =  $1.274/1.475 = 0.864$ , Duty factor =  $10 * \log( 1/0.864) = 0.64$

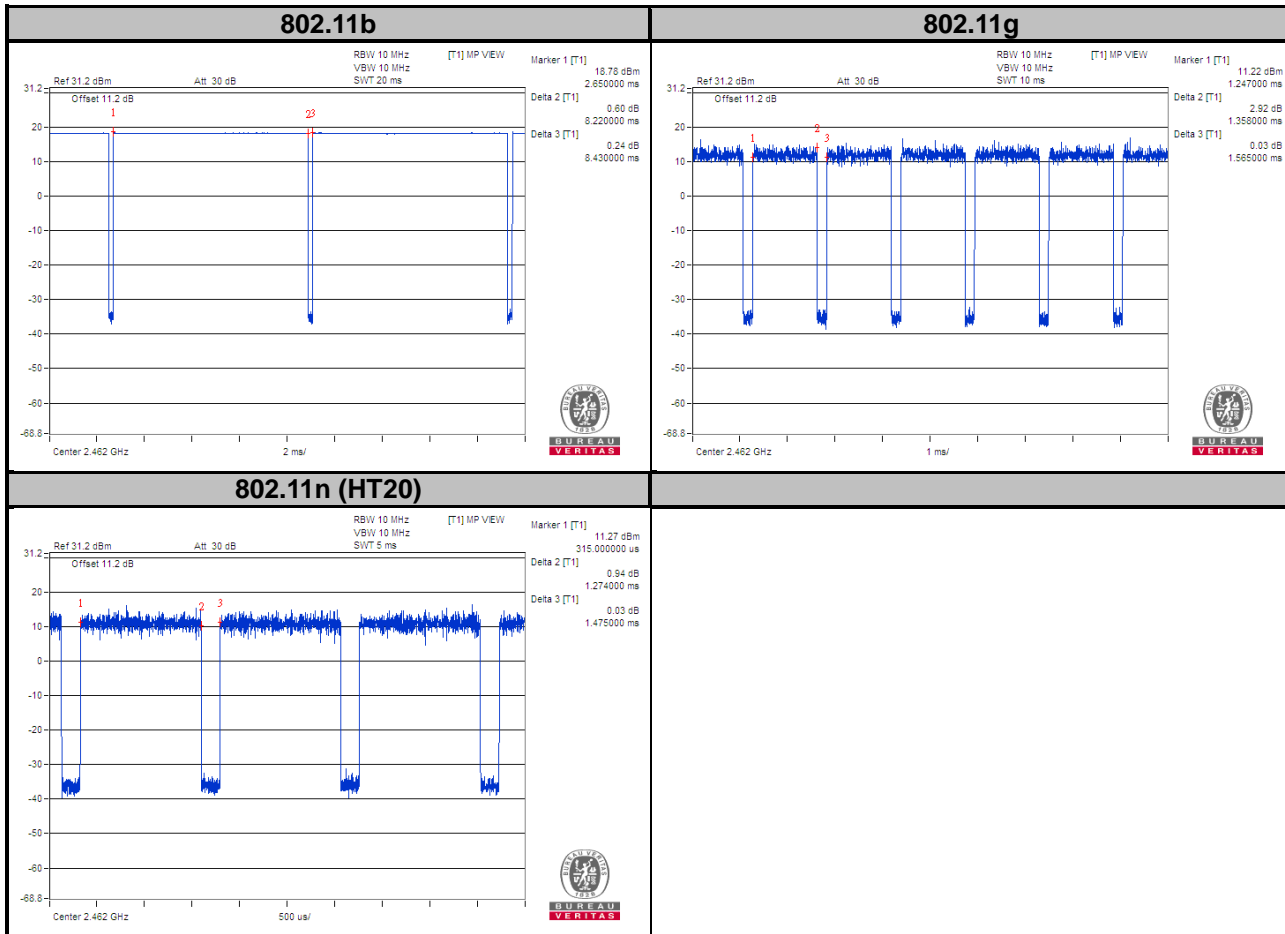

### 3.4 Description of Support Units

The EUT has been tested as an independent unit together with other necessary accessories or support units. The following support units or accessories were used to form a representative test configuration during the tests.

No.	Product	Brand	Model No.	Serial No.	FCC ID
1.	Bluetooth Tester	R&S	CBT	100980	N/A
2.	Adapter	HTC	TC U250	N/A	N/A

No.	Signal Cable Description Of The Above Support Units
1.	N/A
2.	1m shielded cable

Note:

1. All power cords of the above support units are non-shielded (1.8m).
2. Items 1 acted as communication partners to transfer data.

#### 3.4.1 Configuration of System under Test

<Bluetooth EDR>

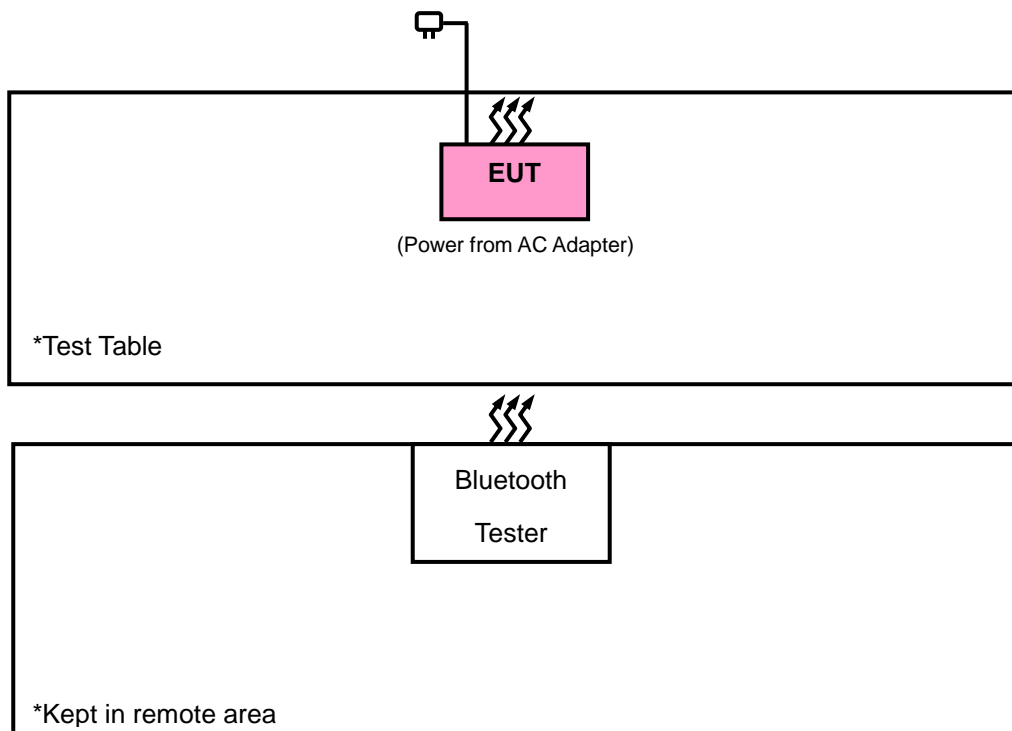

<Bluetooth LE & WLAN>

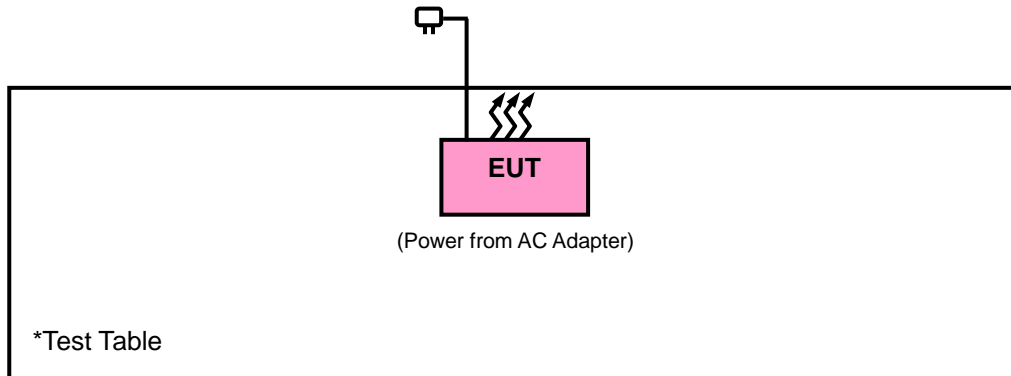

### 3.5 General Description of Applied Standards

The EUT is a RF Product. According to the specifications of the manufacturer, it must comply with the requirements of the following standards:

**FCC Part 15, Subpart C (15.247)**

**KDB 558074 D01 15.247 Meas Guidance v05**

ANSI C63.10-2013

All test items have been performed and recorded as per the above standards.

## 4 Test Types and Results

### <BLUETOOTH EDR>

#### 4.1 Radiated Emission and Bandedge Measurement

##### 4.1.1 Limits of Radiated Emission and Bandedge Measurement

Radiated emissions which fall in the restricted bands must comply with the radiated emission limits specified as below table. Other emissions shall be at least 20 dB below the highest level of the desired power:

Frequencies (MHz)	Field Strength (microvolts/meter)	Measurement Distance (meters)
0.009 ~ 0.490	2400/F (kHz)	300
0.490 ~ 1.705	24000/F (kHz)	30
1.705 ~ 30.0	30	30
30 ~ 88	100	3
88 ~ 216	150	3
216 ~ 960	200	3
Above 960	500	3

**Note:**

- The lower limit shall apply at the transition frequencies.
- Emission level (dBuV/m) = 20 log Emission level (uV/m).
- For frequencies above 1000 MHz, the field strength limits are based on average detector, however, the peak field strength of any emission shall not exceed the maximum permitted average limits, specified above by more than 20 dB under any condition of modulation.



#### 4.1.2 Test Instruments

Description & Manufacturer	Model No.	Serial No.	Date of Calibration	Due Date of Calibration
Test Receiver Agilent	N9038A	MY51210203	Mar. 16, 2018	Mar. 15, 2019
Spectrum Analyzer Agilent	N9010A	MY52220314	Nov. 24, 2017	Nov. 23, 2018
Spectrum Analyzer ROHDE & SCHWARZ	FSU43	101261	Jan. 11, 2018	Jan. 10, 2019
Double Ridge Guide Horn Antenna EMCO	3115	5619	Nov. 30, 2017	Nov. 29, 2018
BILOG Antenna SCHWARZBECK	VULB 9168	9168-153	Dec. 06, 2017	Dec. 05, 2018
RF signal cable ETS-LINDGREN	5D-FB	Cable-CH1-01(RFC -SMS-100-SMS-12 0+RFC-SMS-100-S MS-400)	Jun. 19, 2018	Jun. 18, 2019
Fixed Attenuator Mini-Circuits	MDCS18N-10	MDCS18N-10-01	Apr. 16, 2018	Apr. 15, 2019
Loop Antenna TESEQ	HLA 6121	45745	Jun. 14, 2018	Jun. 13, 2019
Bluetooth Tester	CBT	100980	Jul. 28, 2017	Jul. 27, 2019
Preamplifier EMCI	EMC001340	980201	Nov. 01, 2017	Oct. 30, 2018
Preamplifier EMCI	EMC 012645	980115	Oct. 20, 2017	Oct. 19, 2018
Preamplifier EMCI	EMC 184045	980116	Oct. 20, 2017	Oct. 19, 2018
Preamplifier EMCI	EMC 330H	980112	Oct. 13, 2017	Oct. 12, 2018
Power Meter Anritsu	ML2495A	1232002	Dec. 07, 1017	Dec. 06, 2018
Power Sensor Anritsu	MA2411B	1207325	Dec. 07, 1017	Dec. 06, 2018
RF Coaxial Cable HUBER+SUHNNER	EMC104-SM-SM-8 000&3000	140811+170717	Oct. 20, 2017	Oct. 19, 2018
RF Coaxial Cable HUBER+SUHNNER	SUCOFLEX 104	EMC104-SM-SM-1 000(140807)	Oct. 20, 2017	Oct. 19, 2018
RF Coaxial Cable Worken	8D-FB	Cable-Ch10-01	Oct. 20, 2017	Oct. 19, 2018
Boresight Antenna Fixture	FBA-01	FBA-SIP01	NA	NA
Software BV ADT	E3 6.120103	NA	NA	NA
Antenna Tower MF	MFA-440H	NA	NA	NA
Turn Table MF	MFT-201SS	NA	NA	NA

Antenna Tower & Turn Table Controller MF	MF-7802	NA	NA	NA
--	---------	----	----	----

- Note: 1. The calibration interval of the above test instruments is 12 / 24 months and the calibrations are traceable to NML/ROC and NIST/USA.
2. The test was performed in HwaYa Chamber 10.
3. The horn antenna and preamplifier (model: EMC 184045) are used only for the measurement of emission frequency above 1 GHz if tested.
4. The IC Site Registration No. is IC7450F-10.

#### 4.1.3 Test Procedures

##### **For Radiated Emission below 30 MHz**

- a. The EUT was placed on the top of a rotating table 0.8 meters above the ground at a 3 meter chamber room. The table was rotated 360 degrees to determine the position of the highest radiation.
- b. The EUT was set 3 meters away from the interference-receiving antenna, which was mounted on the top of a variable-height antenna tower.
- c. Both Parallel, perpendicular, and ground-parallel orientations of the antenna are set to make the measurement.
- d. For each suspected emission, the EUT was arranged to its worst case and the rotatable table was turned from 0 degrees to 360 degrees to find the maximum reading.
- e. The test-receiver system was set to Quasi-Peak Detect Function and Specified Bandwidth with Maximum Hold Mode.

##### **Note:**

1. The resolution bandwidth and video bandwidth of test receiver/spectrum analyzer is 9 kHz at frequency below 30 MHz.
2. There is a comparison data of both open-field test site and semi-Anechoic chamber, and the result came out very similar.

##### **For Radiated Emission above 30 MHz**

- a. The EUT was placed on the top of a rotating table 0.8 meters (for 30 MHz ~ 1 GHz) / 1.5 meters (for above 1 GHz) above the ground at 3 meter chamber room for test. The table was rotated 360 degrees to determine the position of the highest radiation.
- b. The EUT was set 3 meters away from the interference-receiving antenna, which was mounted on the top of a variable-height antenna tower.
- c. The height of antenna is varied from one meter to four meters above the ground to determine the maximum value of the field strength. Both horizontal and vertical polarizations of the antenna are set to make the measurement.
- d. For each suspected emission, the EUT was arranged to its worst case and then the antenna was tuned to heights from 1 meter to 4 meters and the rotatable table was turned from 0 degrees to 360 degrees to find the maximum reading.
- e. The test-receiver system was set to quasi-peak detect function and specified bandwidth with maximum hold mode when the test frequency is below 1 GHz.
- f. The test-receiver system was set to peak and average detected function and specified bandwidth with maximum hold mode when the test frequency is above 1 GHz. If the peak reading value also meets average limit, measurement with the average detector is unnecessary.

##### **Note:**

1. The resolution bandwidth and video bandwidth of test receiver/spectrum analyzer is 120 kHz for Quasi-peak detection (QP) at frequency below 1 GHz.
2. The resolution bandwidth of test receiver/spectrum analyzer is 1 MHz and the video bandwidth is 3 MHz for Peak detection (PK) at frequency above 1 GHz.
3. The resolution bandwidth of test receiver/spectrum analyzer is 1 MHz and the video bandwidth is  $\geq 1/T$  (Duty cycle < 98 %) or 10 Hz (Duty cycle  $\geq 98$  %) for Average detection (AV) at frequency above 1 GHz. (RBW = 1 MHz, VBW = 1 kHz)
4. All modes of operation were investigated and the worst-case emissions are reported.

4.1.4 Deviation from Test Standard

No deviation.

4.1.5 Test Setup

<Radiated Emission below 30 MHz>

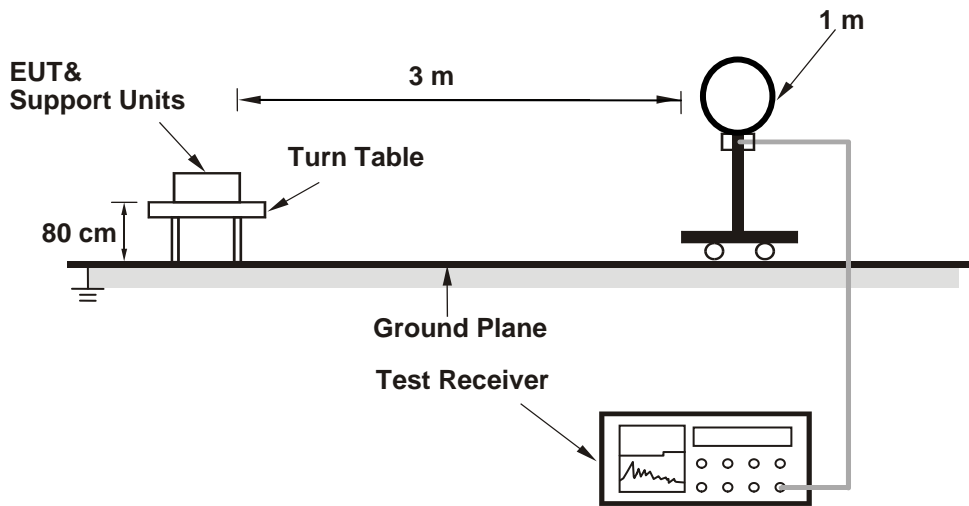

<Radiated Emission 30 MHz to 1 GHz>

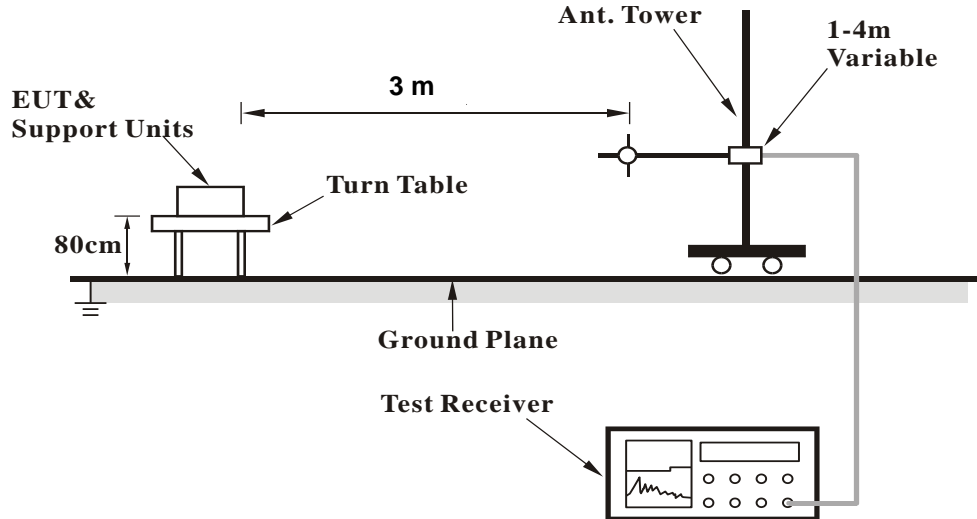

**<Radiated Emission above 1 GHz>**

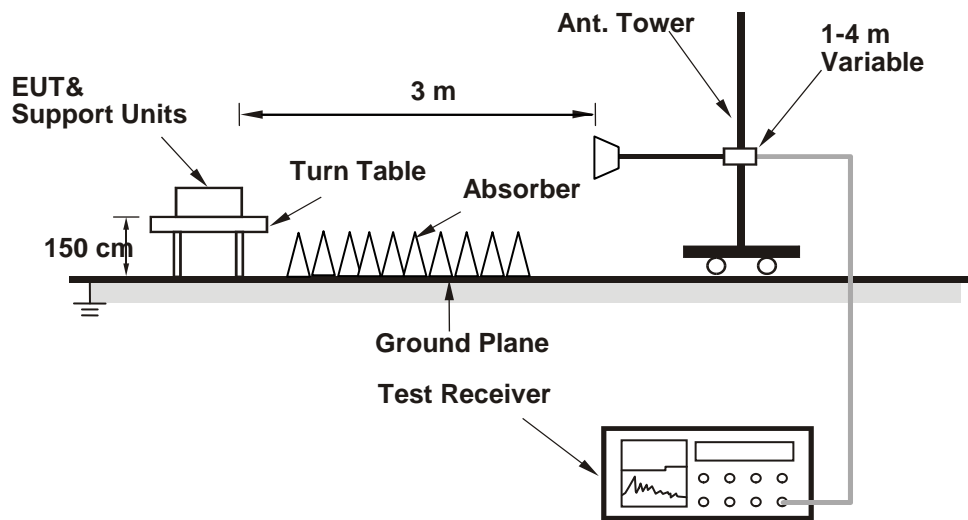

For the actual test configuration, please refer to the attached file (Test Setup Photo).

**4.1.6 EUT Operating Conditions**

Set the EUT under transmission condition continuously at specific channel frequency.

#### 4.1.7 Test Results

##### Above 1 GHz Data:

Mode A

GFSK

EUT Test Condition		Measurement Detail	
Channel	Channel 0	Frequency Range	1 GHz ~ 25 GHz
Input Power	120 Vac, 60 Hz	Detector Function	Peak (PK) Average (AV)
Environmental Conditions	25 deg. C, 65 % RH	Tested By	Thomas Wei

#### Horizontal

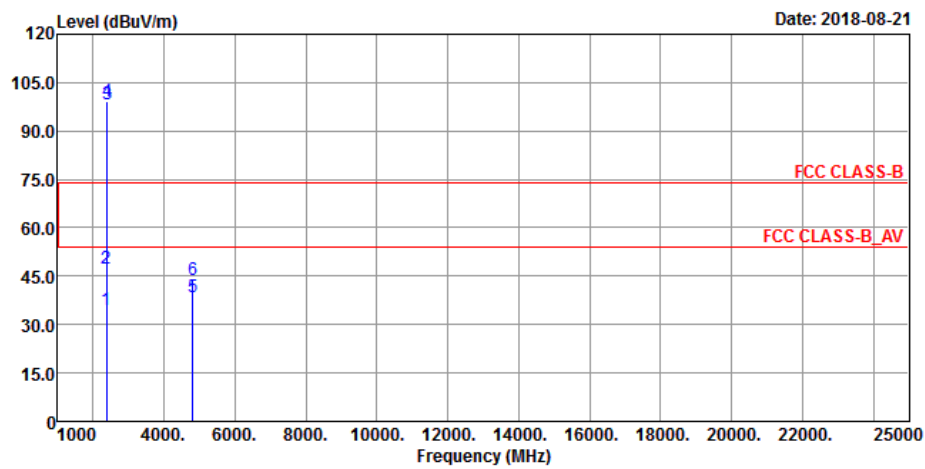

#### Vertical

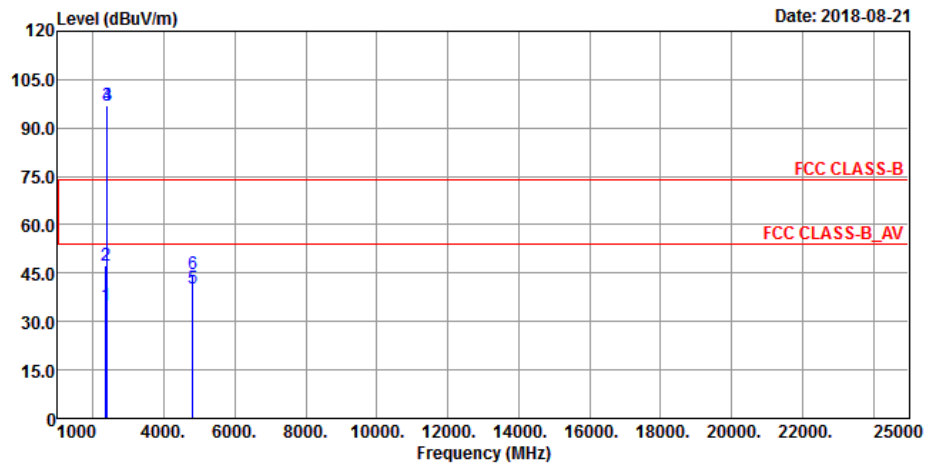

Antenna Polarity & Test Distance: Horizontal at 3 m										
Frequency (MHz)	Emission Level (dBuV/m)	Read Level (dBuV)	Limit (dBuV/m)	Margin (dB)	Antenna Factor (dB/m)	Cable Loss (dB)	Preamp Factor (dB)	Antenna Height (cm)	Table Angle (Degree)	Remark
2378.06	34.37	40.44	54	-19.63	27.08	4.35	37.5	133	284	Average
2378.06	47.57	53.64	74	-26.43	27.08	4.35	37.5	133	284	Peak
2402	98.38	104.37			27.16	4.37	37.52	133	284	Average
2402	99.2	105.19			27.16	4.37	37.52	133	284	Peak
4804	38.64	54.33	54	-15.36	31.14	6.07	52.9	128	114	Average
4804	44.02	59.71	74	-29.98	31.14	6.07	52.9	128	114	Peak
Antenna Polarity & Test Distance: Vertical at 3 m										
Frequency (MHz)	Emission Level (dBuV/m)	Read Level (dBuV)	Limit (dBuV/m)	Margin (dB)	Antenna Factor (dB/m)	Cable Loss (dB)	Preamp Factor (dB)	Antenna Height (cm)	Table Angle (Degree)	Remark
2357.16	34.94	40.93	54	-19.06	27.16	4.35	37.5	164	66	Average
2357.16	47.19	53.18	74	-26.81	27.16	4.35	37.5	164	66	Peak
2402	96.83	102.82			27.16	4.37	37.52	164	66	Average
2402	97.17	103.16			27.16	4.37	37.52	164	66	Peak
4804	40.32	56.01	54	-13.68	31.14	6.07	52.9	147	193	Average
4804	44.71	60.4	74	-29.29	31.14	6.07	52.9	147	193	Peak

Remarks:

1. Emission Level = Read Level + Antenna Factor + Cable Loss - Preamp Factor  
Margin value = Emission level – Limit value
2. 2402 MHz: Fundamental frequency.
3. The other emission levels were very low against the limit.

EUT Test Condition		Measurement Detail	
Channel	Channel 39	Frequency Range	1 GHz ~ 25 GHz
Input Power	120 Vac, 60 Hz	Detector Function	Peak (PK) Average (AV)
Environmental Conditions	25 deg. C, 65 % RH	Tested By	Thomas Wei

**Horizontal**

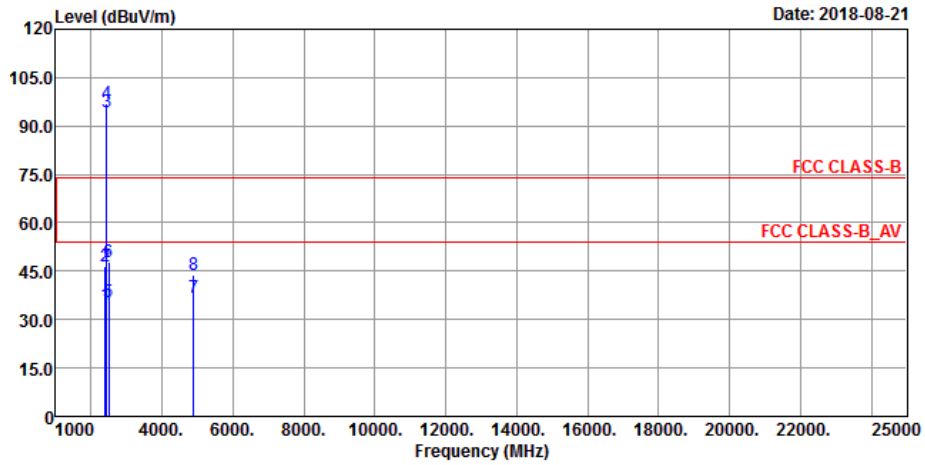

**Vertical**

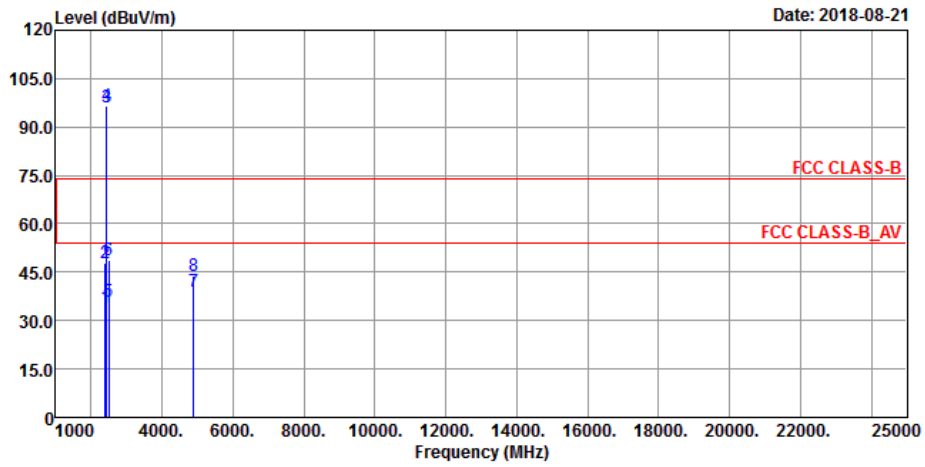



**Antenna Polarity & Test Distance: Horizontal at 3 m**

Frequency (MHz)	Emission Level (dBuV/m)	Read Level (dBuV)	Limit (dBuV/m)	Margin (dB)	Antenna Factor (dB/m)	Cable Loss (dB)	Preamp Factor (dB)	Antenna Height (cm)	Table Angle (Degree)	Remark
2384.55	34.7	40.78	54	-19.3	27.08	4.34	37.5	138	182	Average
2384.55	46.59	52.67	74	-27.41	27.08	4.34	37.5	138	182	Peak
2441	94.42	100.03			27.38	4.4	37.39	138	182	Average
2441	97.02	102.63			27.38	4.4	37.39	138	182	Peak
2489.37	35.53	40.73	54	-18.47	27.61	4.44	37.25	138	182	Average
2489.37	47.83	53.03	74	-26.17	27.61	4.44	37.25	138	182	Peak
4882	36.74	52.19	54	-17.26	31.25	6.16	52.86	128	243	Average
4882	43.92	59.38	74	-30.08	31.25	6.15	52.86	128	243	Peak

**Antenna Polarity & Test Distance: Vertical at 3 m**

Frequency (MHz)	Emission Level (dBuV/m)	Read Level (dBuV)	Limit (dBuV/m)	Margin (dB)	Antenna Factor (dB/m)	Cable Loss (dB)	Preamp Factor (dB)	Antenna Height (cm)	Table Angle (Degree)	Remark
2389.77	34.24	40.23	54	-19.76	27.16	4.35	37.5	185	63	Average
2389.77	47.82	53.81	74	-26.18	27.16	4.35	37.5	185	63	Peak
2441	96.12	101.73			27.38	4.4	37.39	185	63	Average
2441	96.59	102.2			27.38	4.4	37.39	185	63	Peak
2499.58	36.03	41.23	54	-17.97	27.61	4.44	37.25	185	63	Average
2499.58	48.92	54.12	74	-25.08	27.61	4.44	37.25	185	63	Peak
4882	38.97	54.42	54	-15.03	31.25	6.16	52.86	149	147	Average
4882	43.98	59.44	74	-30.02	31.25	6.15	52.86	149	147	Peak

Remarks:

- Emission Level = Read Level + Antenna Factor + Cable Loss - Preamp Factor  
Margin value = Emission level – Limit value
- 2441 MHz: Fundamental frequency.
- The other emission levels were very low against the limit.

EUT Test Condition		Measurement Detail	
Channel	Channel 78	Frequency Range	1 GHz ~ 25 GHz
Input Power	120 Vac, 60 Hz	Detector Function	Peak (PK) Average (AV)
Environmental Conditions	25 deg. C, 65 % RH	Tested By	Thomas Wei

### Horizontal

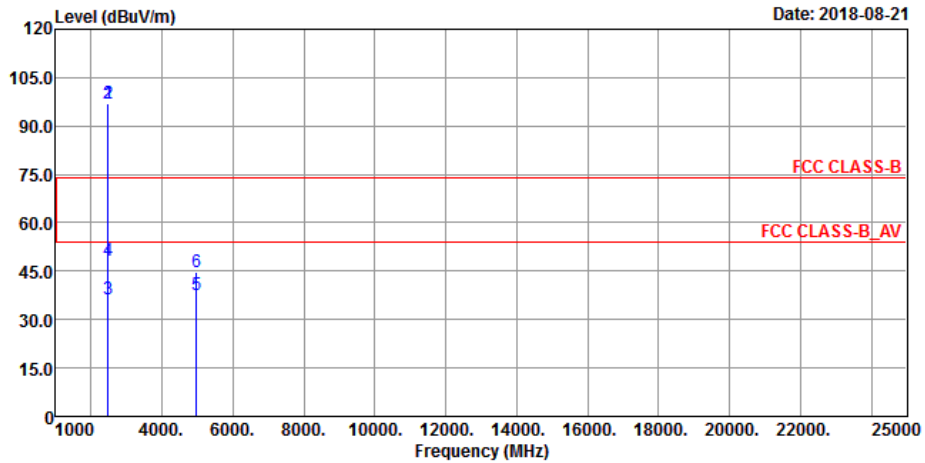

### Vertical

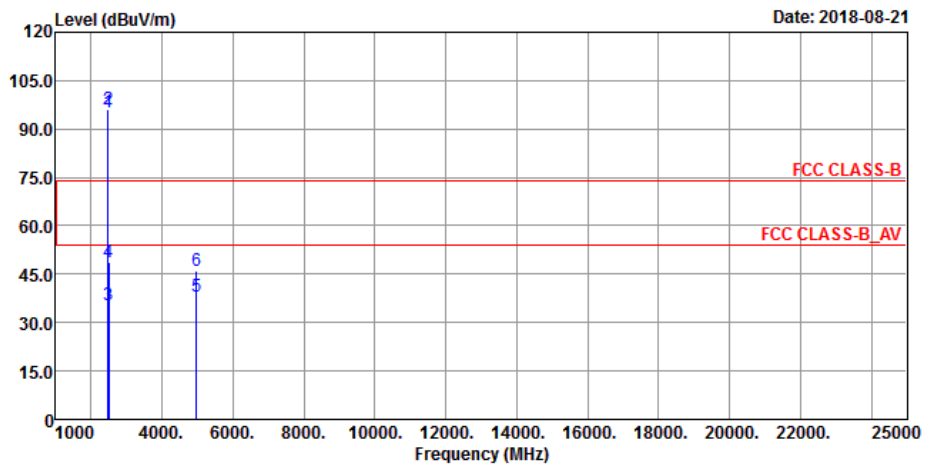

Antenna Polarity & Test Distance: Horizontal at 3 m										
Frequency (MHz)	Emission Level (dBuV/m)	Read Level (dBuV)	Limit (dBuV/m)	Margin (dB)	Antenna Factor (dB/m)	Cable Loss (dB)	Preamp Factor (dB)	Antenna Height (cm)	Table Angle (Degree)	Remark
2480	96.8	102.16			27.53	4.43	37.32	125	274	Average
2480	97.19	102.55			27.53	4.43	37.32	125	274	Peak
2483.68	36.45	41.81	54	-17.55	27.53	4.43	37.32	125	274	Average
2483.68	48.22	53.58	74	-25.78	27.53	4.43	37.32	125	274	Peak
4960	37.46	52.78	54	-16.54	31.4	6.2	52.92	137	203	Average
4960	44.7	60.02	74	-29.3	31.4	6.2	52.92	137	203	Peak
Antenna Polarity & Test Distance: Vertical at 3 m										
Frequency (MHz)	Emission Level (dBuV/m)	Read Level (dBuV)	Limit (dBuV/m)	Margin (dB)	Antenna Factor (dB/m)	Cable Loss (dB)	Preamp Factor (dB)	Antenna Height (cm)	Table Angle (Degree)	Remark
2480	95.25	100.61			27.53	4.43	37.32	172	256	Average
2480	95.87	101.23			27.53	4.43	37.32	172	256	Peak
2491.17	35.23	40.59	54	-18.77	27.53	4.43	37.32	172	256	Average
2491.17	48.51	53.87	74	-25.49	27.53	4.43	37.32	172	256	Peak
4960	37.9	53.22	54	-16.1	31.4	6.2	52.92	155	201	Average
4960	45.98	61.3	74	-28.02	31.4	6.2	52.92	155	201	Peak

Remarks:

1. Emission Level = Read Level + Antenna Factor + Cable Loss - Preamp Factor  
Margin value = Emission level – Limit value
2. 2480 MHz: Fundamental frequency.
3. The other emission levels were very low against the limit.

### 8DPSK

EUT Test Condition		Measurement Detail	
Channel	Channel 0	Frequency Range	1 GHz ~ 25 GHz
Input Power	120 Vac, 60 Hz	Detector Function	Peak (PK) Average (AV)
Environmental Conditions	25 deg. C, 65 % RH	Tested By	Thomas Wei

#### Horizontal

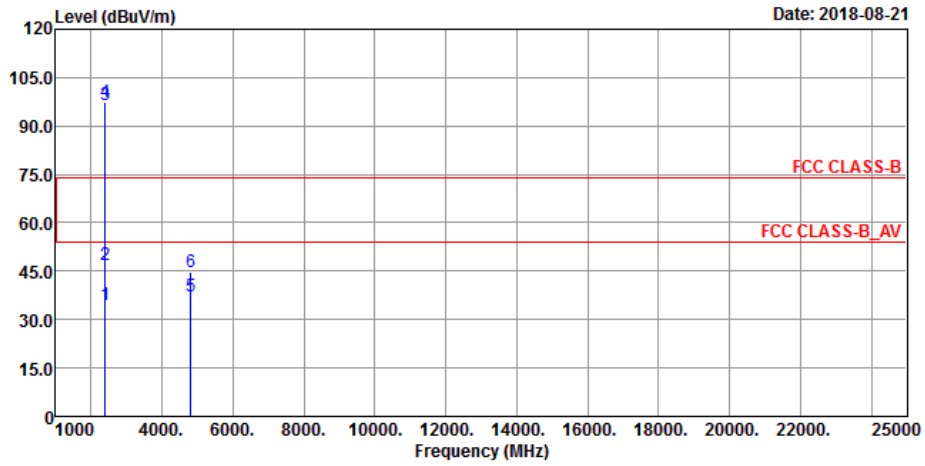

#### Vertical

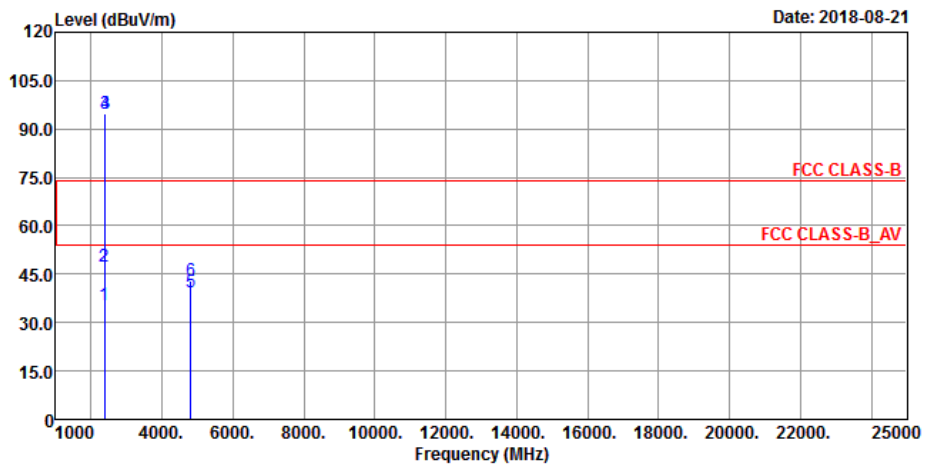

Antenna Polarity & Test Distance: Horizontal at 3 m										
Frequency (MHz)	Emission Level (dBuV/m)	Read Level (dBuV)	Limit (dBuV/m)	Margin (dB)	Antenna Factor (dB/m)	Cable Loss (dB)	Preamp Factor (dB)	Antenna Height (cm)	Table Angle (Degree)	Remark
2388.29	34.72	40.79	54	-19.28	27.08	4.35	37.5	144	281	Average
2388.29	47.09	53.16	74	-26.91	27.08	4.35	37.5	144	281	Peak
2402	96.63	102.62			27.16	4.37	37.52	144	281	Average
2402	97.47	103.46			27.16	4.37	37.52	144	281	Peak
4804	36.99	52.68	54	-17.01	31.14	6.07	52.9	116	319	Average
4804	44.72	60.41	74	-29.28	31.14	6.07	52.9	116	319	Peak
Antenna Polarity & Test Distance: Vertical at 3 m										
Frequency (MHz)	Emission Level (dBuV/m)	Read Level (dBuV)	Limit (dBuV/m)	Margin (dB)	Antenna Factor (dB/m)	Cable Loss (dB)	Preamp Factor (dB)	Antenna Height (cm)	Table Angle (Degree)	Remark
2366.48	35.34	41.33	54	-18.66	27.16	4.35	37.5	159	72	Average
2366.48	47.6	53.59	74	-26.4	27.16	4.35	37.5	159	72	Peak
2402	94.59	100.58			27.16	4.37	37.52	159	72	Average
2402	94.97	100.96			27.16	4.37	37.52	159	72	Peak
4804	39.42	55.11	54	-14.58	31.14	6.07	52.9	184	71	Average
4804	43.06	58.75	74	-30.94	31.14	6.07	52.9	184	71	Peak

Remarks:

1. Emission Level = Read Level + Antenna Factor + Cable Loss - Preamp Factor  
Margin value = Emission level – Limit value
2. 2402 MHz: Fundamental frequency.
3. The other emission levels were very low against the limit.

EUT Test Condition		Measurement Detail	
Channel	Channel 39	Frequency Range	1 GHz ~ 25 GHz
Input Power	120 Vac, 60 Hz	Detector Function	Peak (PK) Average (AV)
Environmental Conditions	25 deg. C, 65 % RH	Tested By	Thomas Wei

### Horizontal

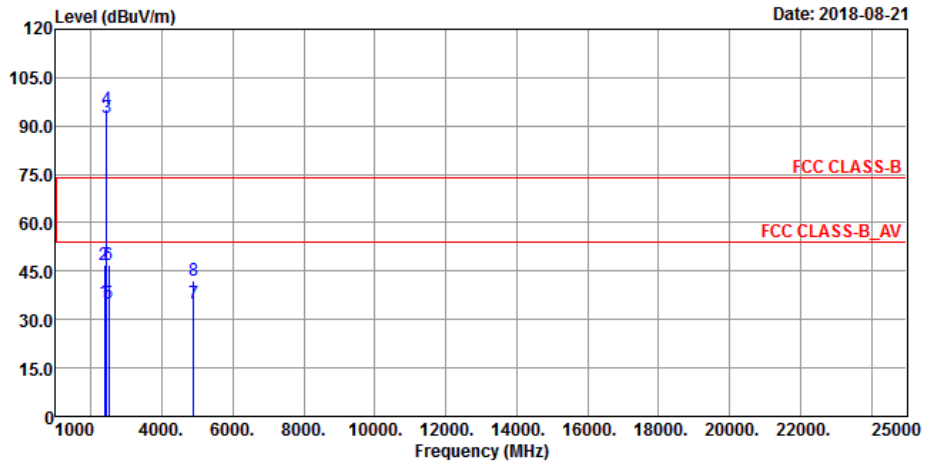

### Vertical

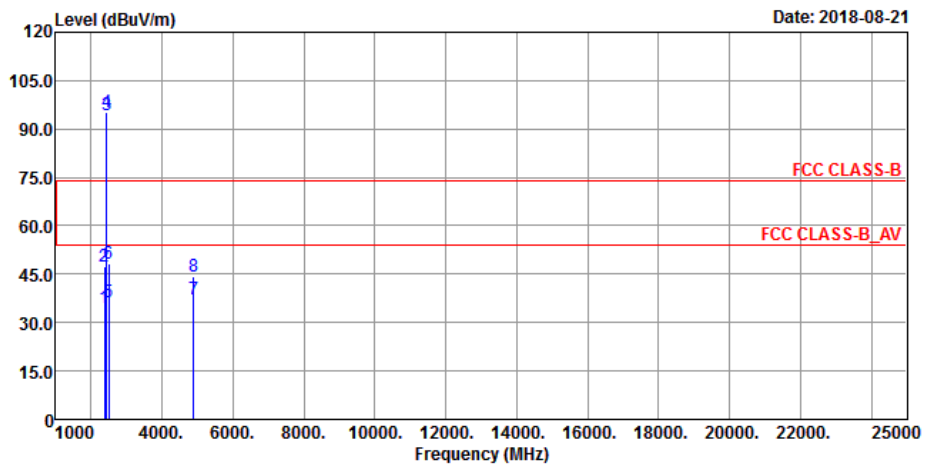

**Antenna Polarity & Test Distance: Horizontal at 3 m**

Frequency (MHz)	Emission Level (dBuV/m)	Read Level (dBuV)	Limit (dBuV/m)	Margin (dB)	Antenna Factor (dB/m)	Cable Loss (dB)	Preamp Factor (dB)	Antenna Height (cm)	Table Angle (Degree)	Remark
2379.55	35.37	41.45	54	-18.63	27.08	4.34	37.5	155	196	Average
2379.55	46.94	53.02	74	-27.06	27.08	4.34	37.5	155	196	Peak
2441	92.51	98.12			27.38	4.4	37.39	155	196	Average
2441	95.36	100.97			27.38	4.4	37.39	155	196	Peak
2485.33	35.13	40.33	54	-18.87	27.61	4.44	37.25	155	196	Average
2485.33	46.93	52.13	74	-27.07	27.61	4.44	37.25	155	196	Peak
4882	34.94	50.39	54	-19.06	31.25	6.16	52.86	142	157	Average
4882	42.01	57.47	74	-31.99	31.25	6.15	52.86	142	157	Peak

**Antenna Polarity & Test Distance: Vertical at 3 m**

Frequency (MHz)	Emission Level (dBuV/m)	Read Level (dBuV)	Limit (dBuV/m)	Margin (dB)	Antenna Factor (dB/m)	Cable Loss (dB)	Preamp Factor (dB)	Antenna Height (cm)	Table Angle (Degree)	Remark
2371.9	34.65	40.64	54	-19.35	27.16	4.35	37.5	177	68	Average
2371.9	47.19	53.18	74	-26.81	27.16	4.35	37.5	177	68	Peak
2441	94.15	99.76			27.38	4.4	37.39	177	68	Average
2441	95.28	100.89			27.38	4.4	37.39	177	68	Peak
2499.58	36.52	41.72	54	-17.48	27.61	4.44	37.25	177	68	Average
2499.58	48.25	53.45	74	-25.75	27.61	4.44	37.25	177	68	Peak
4882	37.27	52.72	54	-16.73	31.25	6.16	52.86	161	227	Average
4882	44.29	59.75	74	-29.71	31.25	6.15	52.86	161	227	Peak

Remarks:

- Emission Level = Read Level + Antenna Factor + Cable Loss - Preamp Factor  
Margin value = Emission level – Limit value
- 2441 MHz: Fundamental frequency.
- The other emission levels were very low against the limit.

EUT Test Condition		Measurement Detail	
Channel	Channel 78	Frequency Range	1 GHz ~ 25 GHz
Input Power	120 Vac, 60 Hz	Detector Function	Peak (PK) Average (AV)
Environmental Conditions	25 deg. C, 65 % RH	Tested By	Thomas Wei

### Horizontal

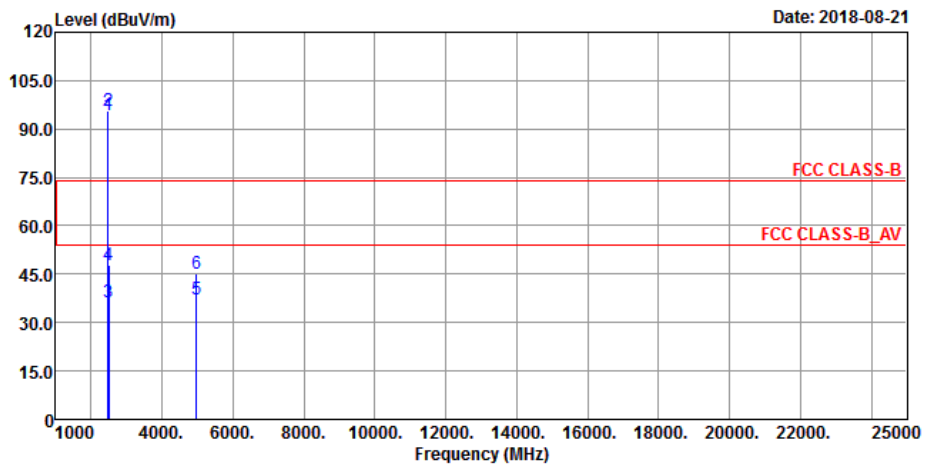

### Vertical

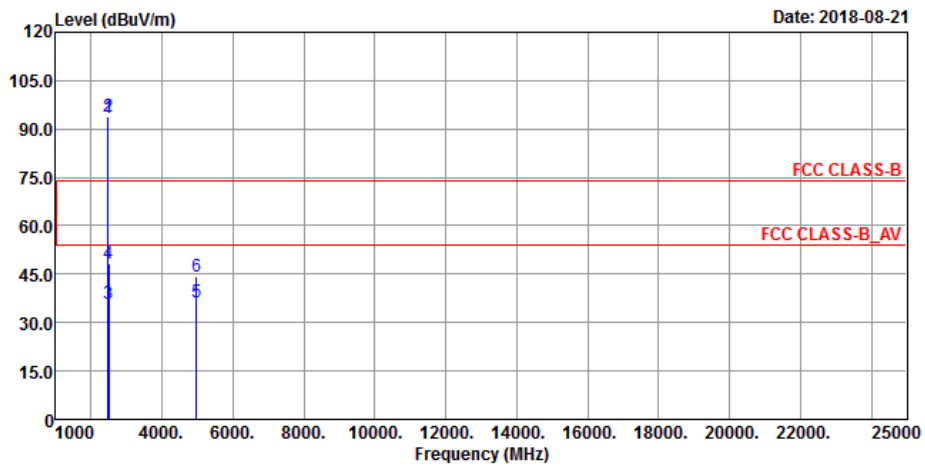



Antenna Polarity & Test Distance: Horizontal at 3 m										
Frequency (MHz)	Emission Level (dBuV/m)	Read Level (dBuV)	Limit (dBuV/m)	Margin (dB)	Antenna Factor (dB/m)	Cable Loss (dB)	Preamp Factor (dB)	Antenna Height (cm)	Table Angle (Degree)	Remark
2480	94.5	99.86			27.53	4.43	37.32	138	262	Average
2480	95.45	100.81			27.53	4.43	37.32	138	262	Peak
2484.88	36.47	41.83	54	-17.53	27.53	4.43	37.32	138	262	Average
2484.88	47.87	53.23	74	-26.13	27.53	4.43	37.32	138	262	Peak
4960	37.05	52.37	74	-36.95	31.4	6.2	52.92	118	126	Average
4960	45.16	60.48	74	-28.84	31.4	6.2	52.92	118	126	Peak
Antenna Polarity & Test Distance: Vertical at 3 m										
Frequency (MHz)	Emission Level (dBuV/m)	Read Level (dBuV)	Limit (dBuV/m)	Margin (dB)	Antenna Factor (dB/m)	Cable Loss (dB)	Preamp Factor (dB)	Antenna Height (cm)	Table Angle (Degree)	Remark
2480	93.39	98.75			27.53	4.43	37.32	164	239	Average
2480	94.07	99.43			27.53	4.43	37.32	164	239	Peak
2486.33	36.03	41.39	54	-17.97	27.53	4.43	37.32	164	239	Average
2486.33	48.41	53.77	74	-25.59	27.53	4.43	37.32	164	239	Peak
4960	36.27	51.59	54	-17.73	31.4	6.2	52.92	133	322	Average
4960	44.28	59.6	74	-29.72	31.4	6.2	52.92	133	322	Peak

Remarks:

1. Emission Level = Read Level + Antenna Factor + Cable Loss - Preamp Factor  
Margin value = Emission level – Limit value
2. 2480 MHz: Fundamental frequency.
3. The other emission levels were very low against the limit.

**Mode B**  
**GFSK**

EUT Test Condition		Measurement Detail	
Channel	Channel 0	Frequency Range	1 GHz ~ 25 GHz
Input Power	120 Vac, 60 Hz	Detector Function	Peak (PK) Average (AV)
Environmental Conditions	25 deg. C, 65 % RH	Tested By	Thomas Wei

**Horizontal**

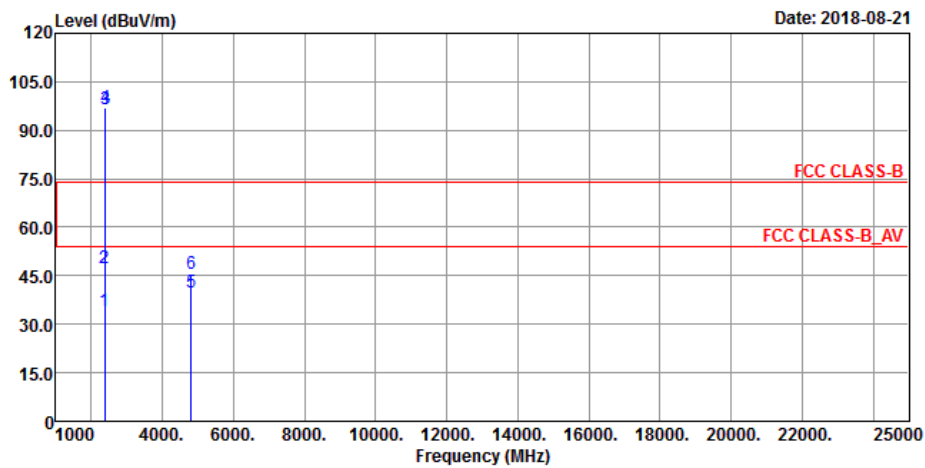

**Vertical**

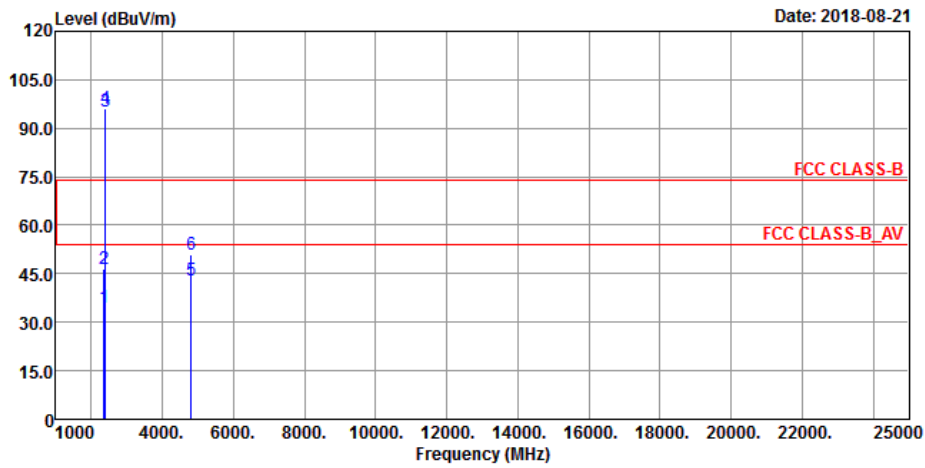

Antenna Polarity & Test Distance: Horizontal at 3 m										
Frequency (MHz)	Emission Level (dBuV/m)	Read Level (dBuV)	Limit (dBuV/m)	Margin (dB)	Antenna Factor (dB/m)	Cable Loss (dB)	Preamp Factor (dB)	Antenna Height (cm)	Table Angle (Degree)	Remark
2381.55	34.29	40.27	54	-19.71	27.16	4.36	37.5	178	192	Average
2381.55	47.36	53.34	74	-26.64	27.16	4.36	37.5	178	192	Peak
2402	96.44	102.43			27.16	4.37	37.52	178	192	Average
2402	96.84	102.83			27.16	4.37	37.52	178	192	Peak
4804	39.97	54.94	54	-14.03	31.14	6.79	52.9	156	103	Average
4804	45.39	60.36	74	-28.61	31.14	6.79	52.9	156	103	Peak
Antenna Polarity & Test Distance: Vertical at 3 m										
Frequency (MHz)	Emission Level (dBuV/m)	Read Level (dBuV)	Limit (dBuV/m)	Margin (dB)	Antenna Factor (dB/m)	Cable Loss (dB)	Preamp Factor (dB)	Antenna Height (cm)	Table Angle (Degree)	Remark
2359.88	34.41	40.39	54	-19.59	27.16	4.36	37.5	132	233	Average
2359.88	46.52	52.5	74	-27.48	27.16	4.36	37.5	132	233	Peak
2402	95.33	101.32			27.16	4.37	37.52	132	233	Average
2402	95.94	101.93			27.16	4.37	37.52	132	233	Peak
4804	42.76	57.73	54	-11.24	31.14	6.79	52.9	161	149	Average
4804	50.91	65.88	74	-23.09	31.14	6.79	52.9	161	149	Peak

Remarks:

1. Emission Level = Read Level + Antenna Factor + Cable Loss - Preamp Factor  
Margin value = Emission level – Limit value
2. 2402 MHz: Fundamental frequency.
3. The other emission levels were very low against the limit.

EUT Test Condition		Measurement Detail	
Channel	Channel 39	Frequency Range	1 GHz ~ 25 GHz
Input Power	120 Vac, 60 Hz	Detector Function	Peak (PK) Average (AV)
Environmental Conditions	25 deg. C, 65 % RH	Tested By	Thomas Wei

### Horizontal

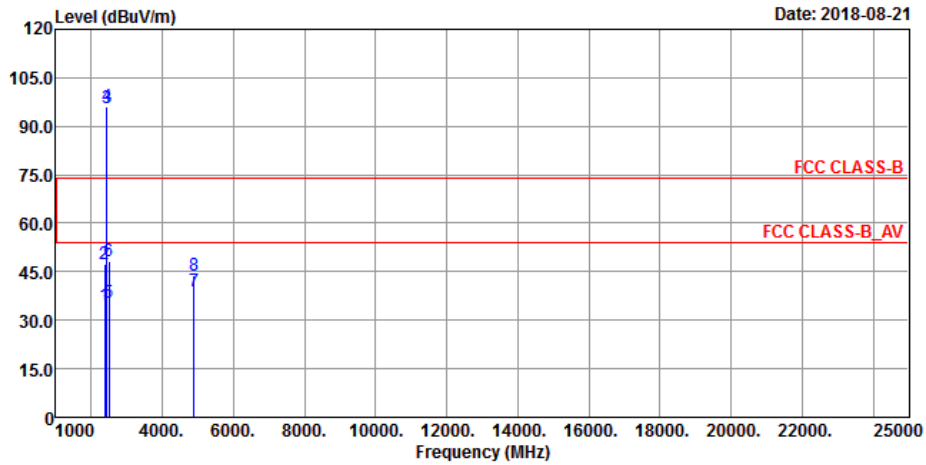

### Vertical

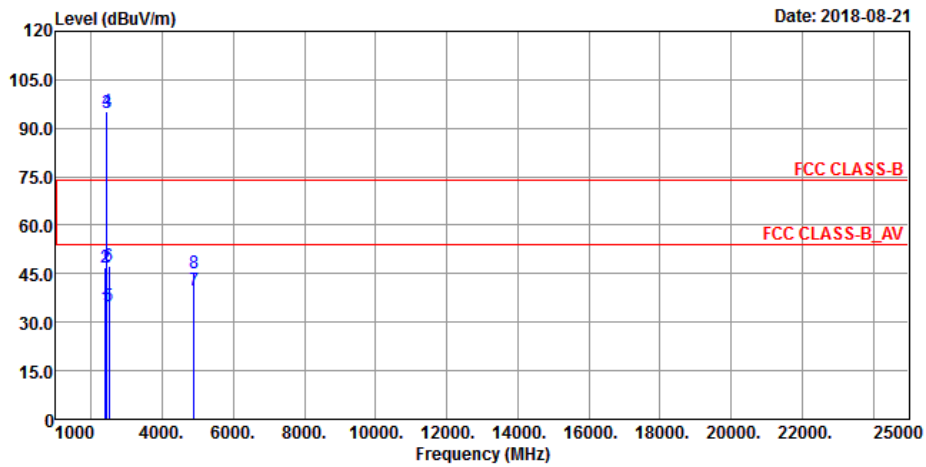

**Antenna Polarity & Test Distance: Horizontal at 3 m**

Frequency (MHz)	Emission Level (dBuV/m)	Read Level (dBuV)	Limit (dBuV/m)	Margin (dB)	Antenna Factor (dB/m)	Cable Loss (dB)	Preamp Factor (dB)	Antenna Height (cm)	Table Angle (Degree)	Remark
2376	34.58	40.65	54	-19.42	27.08	4.35	37.5	170	242	Average
2376	47.52	53.59	74	-26.48	27.08	4.35	37.5	170	242	Peak
2441	95.82	101.43			27.38	4.4	37.39	170	242	Average
2441	96.25	101.86			27.38	4.4	37.39	170	242	Peak
2488.5	35.51	40.71	54	-18.49	27.61	4.44	37.25	170	242	Average
2488.5	48.32	53.52	74	-25.68	27.61	4.44	37.25	170	242	Peak
4882	38.9	54.35	54	-15.1	31.25	6.16	52.86	148	69	Average
4882	43.91	59.37	74	-30.09	31.25	6.15	52.86	148	69	Peak

**Antenna Polarity & Test Distance: Vertical at 3 m**

Frequency (MHz)	Emission Level (dBuV/m)	Read Level (dBuV)	Limit (dBuV/m)	Margin (dB)	Antenna Factor (dB/m)	Cable Loss (dB)	Preamp Factor (dB)	Antenna Height (cm)	Table Angle (Degree)	Remark
2386.9	34.44	40.51	54	-19.56	27.08	4.35	37.5	134	198	Average
2386.9	46.73	52.8	74	-27.27	27.08	4.35	37.5	134	198	Peak
2441	94.72	100.33			27.38	4.4	37.39	134	198	Average
2441	95.03	100.64			27.38	4.4	37.39	134	198	Peak
2498.12	35.19	40.39	54	-18.81	27.61	4.44	37.25	134	198	Average
2498.12	47.57	52.77	74	-26.43	27.61	4.44	37.25	134	198	Peak
4882	39.74	55.19	54	-14.26	31.25	6.16	52.86	163	166	Average
4882	45.04	60.49	74	-28.96	31.25	6.16	52.86	163	166	Peak

Remarks:

- Emission Level = Read Level + Antenna Factor + Cable Loss - Preamp Factor  
Margin value = Emission level – Limit value
- 2441 MHz: Fundamental frequency.
- The other emission levels were very low against the limit.

EUT Test Condition		Measurement Detail	
Channel	Channel 78	Frequency Range	1 GHz ~ 25 GHz
Input Power	120 Vac, 60 Hz	Detector Function	Peak (PK) Average (AV)
Environmental Conditions	25 deg. C, 65 % RH	Tested By	Thomas Wei

### Horizontal

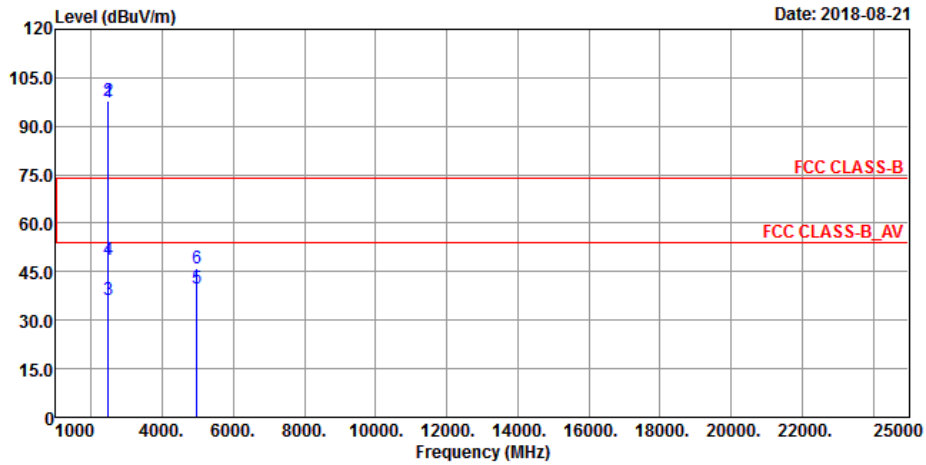

### Vertical

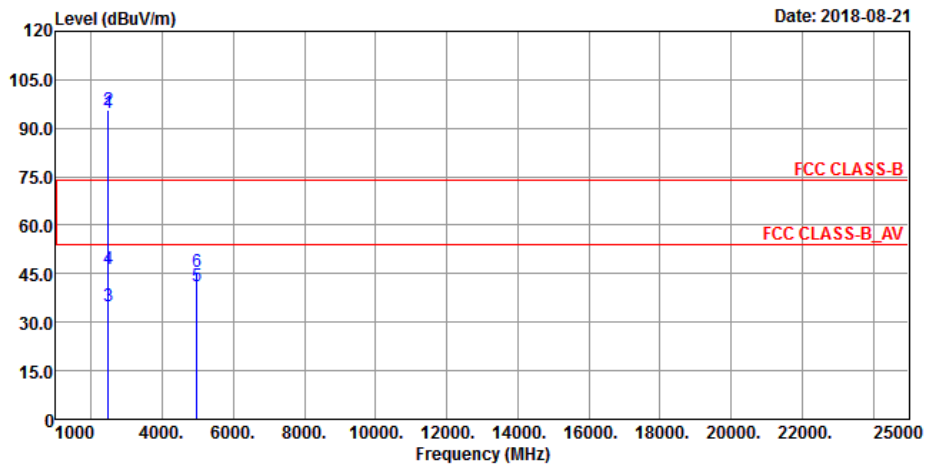

Antenna Polarity & Test Distance: Horizontal at 3 m										
Frequency (MHz)	Emission Level (dBuV/m)	Read Level (dBuV)	Limit (dBuV/m)	Margin (dB)	Antenna Factor (dB/m)	Cable Loss (dB)	Preamp Factor (dB)	Antenna Height (cm)	Table Angle (Degree)	Remark
2480	97.48	102.84			27.53	4.43	37.32	168	241	Average
2480	97.97	103.33			27.53	4.43	37.32	168	241	Peak
2483.52	36.45	41.81	54	-17.55	27.53	4.43	37.32	168	241	Average
2483.52	48.74	54.1	74	-25.26	27.53	4.43	37.32	168	241	Peak
4960	39.85	55.17	54	-14.15	31.4	6.2	52.92	153	220	Average
4960	46.17	61.49	74	-27.83	31.4	6.2	52.92	153	220	Peak
Antenna Polarity & Test Distance: Vertical at 3 m										
Frequency (MHz)	Emission Level (dBuV/m)	Read Level (dBuV)	Limit (dBuV/m)	Margin (dB)	Antenna Factor (dB/m)	Cable Loss (dB)	Preamp Factor (dB)	Antenna Height (cm)	Table Angle (Degree)	Remark
2480	94.85	100.21			27.53	4.43	37.32	138	233	Average
2480	95.59	100.95			27.53	4.43	37.32	138	233	Peak
2483.92	35.18	40.54	54	-18.82	27.53	4.43	37.32	138	233	Average
2483.92	46.33	51.69	74	-27.67	27.53	4.43	37.32	138	233	Peak
4960	41.23	56.55	54	-12.77	31.4	6.2	52.92	142	194	Average
4960	45.76	61.08	74	-28.24	31.4	6.2	52.92	142	194	Peak

Remarks:

1. Emission Level = Read Level + Antenna Factor + Cable Loss - Preamp Factor  
Margin value = Emission level – Limit value
2. 2480 MHz: Fundamental frequency.
3. The other emission levels were very low against the limit.

### 8DPSK

EUT Test Condition		Measurement Detail	
Channel	Channel 0	Frequency Range	1 GHz ~ 25 GHz
Input Power	120 Vac, 60 Hz	Detector Function	Peak (PK) Average (AV)
Environmental Conditions	25 deg. C, 65 % RH	Tested By	Thomas Wei

#### Horizontal

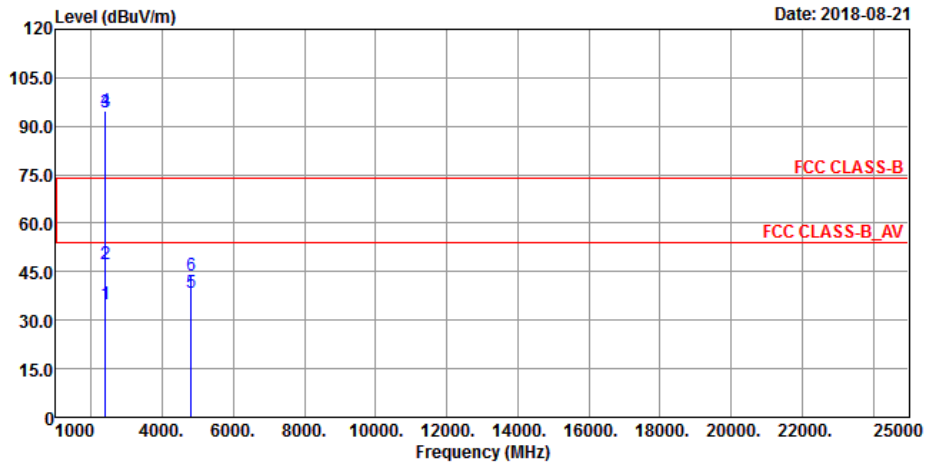

#### Vertical

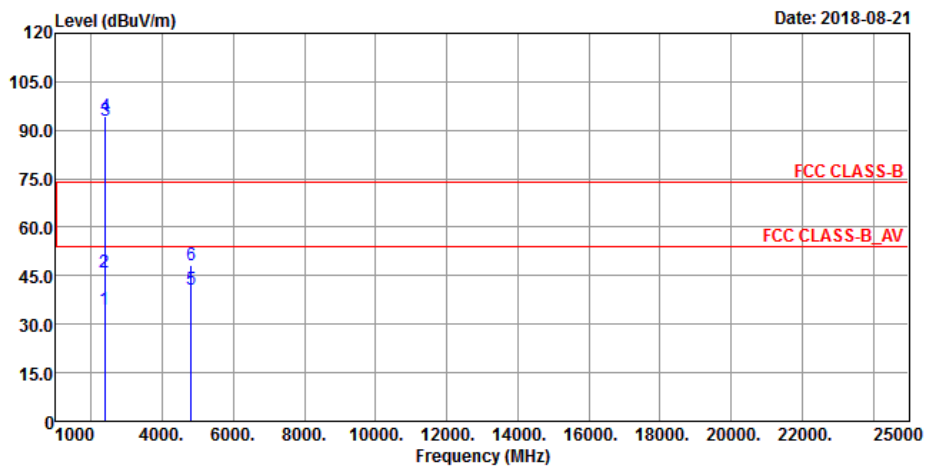



Antenna Polarity & Test Distance: Horizontal at 3 m										
Frequency (MHz)	Emission Level (dBuV/m)	Read Level (dBuV)	Limit (dBuV/m)	Margin (dB)	Antenna Factor (dB/m)	Cable Loss (dB)	Preamp Factor (dB)	Antenna Height (cm)	Table Angle (Degree)	Remark
2387.33	34.79	40.77	54	-19.21	27.16	4.36	37.5	189	211	Average
2387.33	47.55	69.42	74	-26.45	27.16	4.84	53.87	189	211	Peak
2402	94.28	100.27			27.16	4.37	37.52	189	211	Average
2402	94.71	100.7			27.16	4.37	37.52	189	211	Peak
4804	38.66	53.63	54	-15.34	31.14	6.79	52.9	126	203	Average
4804	43.89	58.86	74	-30.11	31.14	6.79	52.9	126	203	Peak
Antenna Polarity & Test Distance: Vertical at 3 m										
Frequency (MHz)	Emission Level (dBuV/m)	Read Level (dBuV)	Limit (dBuV/m)	Margin (dB)	Antenna Factor (dB/m)	Cable Loss (dB)	Preamp Factor (dB)	Antenna Height (cm)	Table Angle (Degree)	Remark
2379.46	34.53	40.51	54	-19.47	27.16	4.36	37.5	147	213	Average
2379.46	46.23	52.21	74	-27.77	27.16	4.36	37.5	147	213	Peak
2402	93.19	99.18			27.16	4.37	37.52	147	213	Average
2402	94.48	100.47			27.16	4.37	37.52	147	213	Peak
4804	40.89	55.86	54	-13.11	31.14	6.79	52.9	179	66	Average
4804	48.12	63.09	74	-25.88	31.14	6.79	52.9	179	66	Peak

Remarks:

1. Emission Level = Read Level + Antenna Factor + Cable Loss - Preamp Factor  
Margin value = Emission level – Limit value
2. 2402 MHz: Fundamental frequency.
3. The other emission levels were very low against the limit.

EUT Test Condition		Measurement Detail	
Channel	Channel 39	Frequency Range	1 GHz ~ 25 GHz
Input Power	120 Vac, 60 Hz	Detector Function	Peak (PK) Average (AV)
Environmental Conditions	25 deg. C, 65 % RH	Tested By	Thomas Wei

### Horizontal

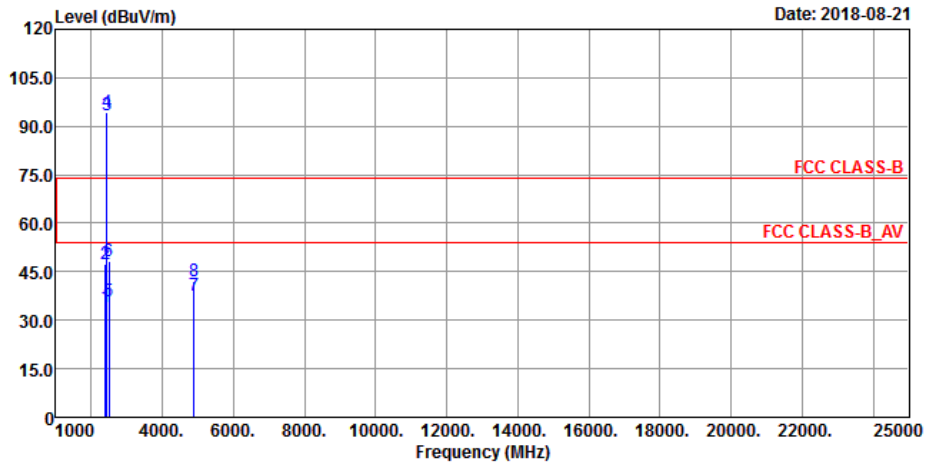

### Vertical

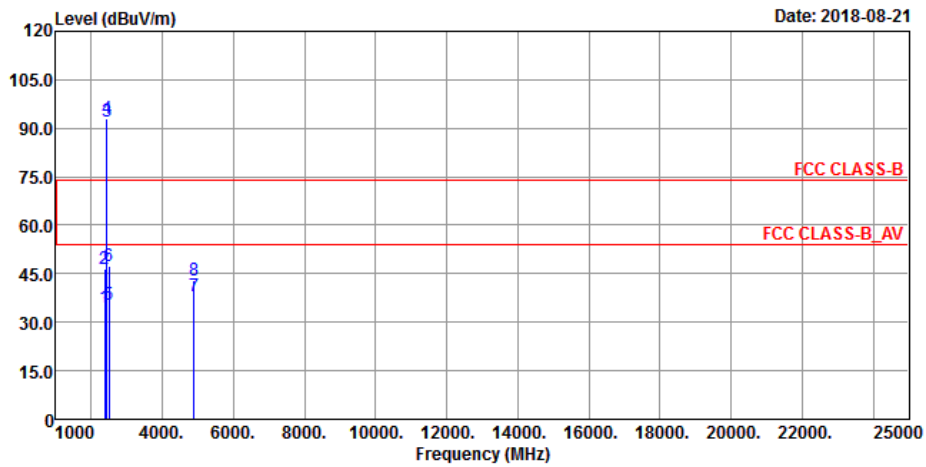

**Antenna Polarity & Test Distance: Horizontal at 3 m**

Frequency (MHz)	Emission Level (dBuV/m)	Read Level (dBuV)	Limit (dBuV/m)	Margin (dB)	Antenna Factor (dB/m)	Cable Loss (dB)	Preamp Factor (dB)	Antenna Height (cm)	Table Angle (Degree)	Remark
2384.22	34.17	40.24	54	-19.83	27.08	4.35	37.5	157	206	Average
2384.22	47.26	53.33	74	-26.74	27.08	4.35	37.5	157	206	Peak
2441	93.51	99.12			27.38	4.4	37.39	157	206	Average
2441	94.4	100.01			27.38	4.4	37.39	157	206	Peak
2492.13	35.71	40.91	54	-18.29	27.61	4.44	37.25	157	206	Average
2492.13	48.06	53.26	74	-25.94	27.61	4.44	37.25	157	206	Peak
4882	37.66	53.11	54	-16.34	31.25	6.16	52.86	127	239	Average
4882	41.88	57.34	74	-32.12	31.25	6.15	52.86	127	239	Peak

**Antenna Polarity & Test Distance: Vertical at 3 m**

Frequency (MHz)	Emission Level (dBuV/m)	Read Level (dBuV)	Limit (dBuV/m)	Margin (dB)	Antenna Factor (dB/m)	Cable Loss (dB)	Preamp Factor (dB)	Antenna Height (cm)	Table Angle (Degree)	Remark
2368.12	34.69	40.76	54	-19.31	27.08	4.35	37.5	152	211	Average
2368.12	46.38	52.45	74	-27.62	27.08	4.35	37.5	152	211	Peak
2441	92.32	97.93			27.38	4.4	37.39	152	211	Average
2441	93.18	98.79			27.38	4.4	37.39	152	211	Peak
2486.5	35.4	40.6	54	-18.6	27.61	4.44	37.25	152	211	Average
2486.5	47.19	52.39	74	-26.81	27.61	4.44	37.25	152	211	Peak
4882	37.92	53.37	54	-16.08	31.25	6.16	52.86	191	87	Average
4882	42.74	58.19	74	-31.26	31.25	6.16	52.86	191	87	Peak

**Remarks:**

- Emission Level = Read Level + Antenna Factor + Cable Loss - Preamp Factor  
Margin value = Emission level – Limit value
- 2441 MHz: Fundamental frequency.
- The other emission levels were very low against the limit.

EUT Test Condition		Measurement Detail	
Channel	Channel 78	Frequency Range	1 GHz ~ 25 GHz
Input Power	120 Vac, 60 Hz	Detector Function	Peak (PK) Average (AV)
Environmental Conditions	25 deg. C, 65 % RH	Tested By	Thomas Wei

### Horizontal

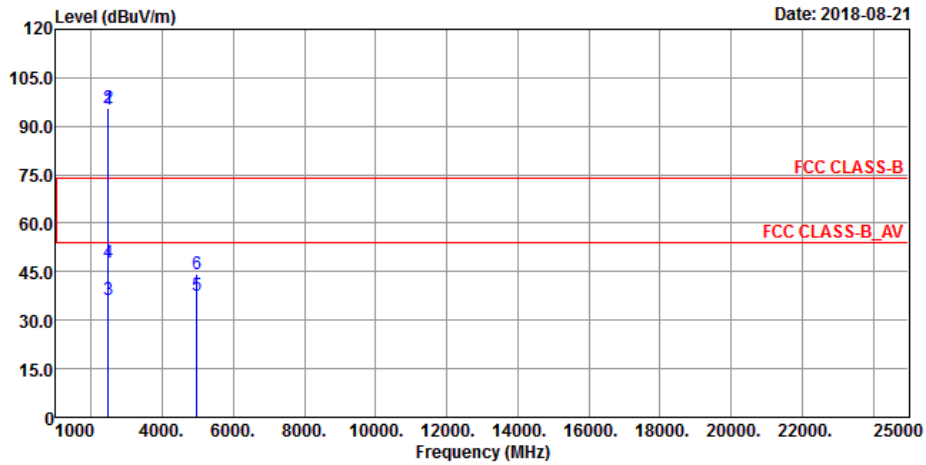

### Vertical

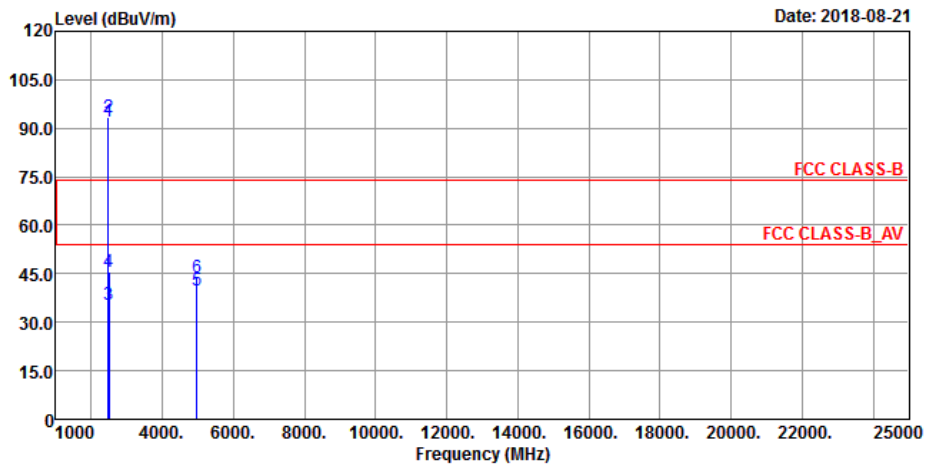

Antenna Polarity & Test Distance: Horizontal at 3 m										
Frequency (MHz)	Emission Level (dBuV/m)	Read Level (dBuV)	Limit (dBuV/m)	Margin (dB)	Antenna Factor (dB/m)	Cable Loss (dB)	Preamp Factor (dB)	Antenna Height (cm)	Table Angle (Degree)	Remark
2480	95.28	100.64			27.53	4.43	37.32	145	272	Average
2480	95.67	101.03			27.53	4.43	37.32	145	272	Peak
2483.97	36.29	41.65	54	-17.71	27.53	4.43	37.32	145	272	Average
2483.97	47.95	53.31	74	-26.05	27.53	4.43	37.32	145	272	Peak
4960	37.45	52.77	54	-16.55	31.4	6.2	52.92	136	155	Average
4960	44.27	59.59	74	-29.73	31.4	6.2	52.92	136	155	Peak
Antenna Polarity & Test Distance: Vertical at 3 m										
Frequency (MHz)	Emission Level (dBuV/m)	Read Level (dBuV)	Limit (dBuV/m)	Margin (dB)	Antenna Factor (dB/m)	Cable Loss (dB)	Preamp Factor (dB)	Antenna Height (cm)	Table Angle (Degree)	Remark
2480	92.13	97.49			27.53	4.43	37.32	153	201	Average
2480	93.35	98.71			27.53	4.43	37.32	153	201	Peak
2485.77	35.59	40.95	54	-18.41	27.53	4.43	37.32	153	201	Average
2485.77	45.66	51.02	74	-28.34	27.53	4.43	37.32	153	201	Peak
4960	39.83	55.15	54	-14.17	31.4	6.2	52.92	182	216	Average
4960	43.81	59.13	74	-30.19	31.4	6.2	52.92	182	216	Peak

Remarks:

1. Emission Level = Read Level + Antenna Factor + Cable Loss - Preamp Factor  
Margin value = Emission level – Limit value
2. 2480 MHz: Fundamental frequency.
3. The other emission levels were very low against the limit.

**9 kHz ~ 30 MHz Data:**

The amplitude of spurious emissions attenuated more than 20 dB below the permissible value is not required to be report.

**30 MHz ~ 1 GHz Worst-Case Data: GFSK**

**Mode A**

EUT Test Condition		Measurement Detail	
Channel	Channel 0	Frequency Range	30 MHz ~ 1 GHz
Input Power	120 Vac, 60 Hz	Detector Function	Peak (PK) Quasi-peak (QP)
Environmental Conditions	25 deg. C, 65 % RH	Tested By	Thomas Wei

**Horizontal**

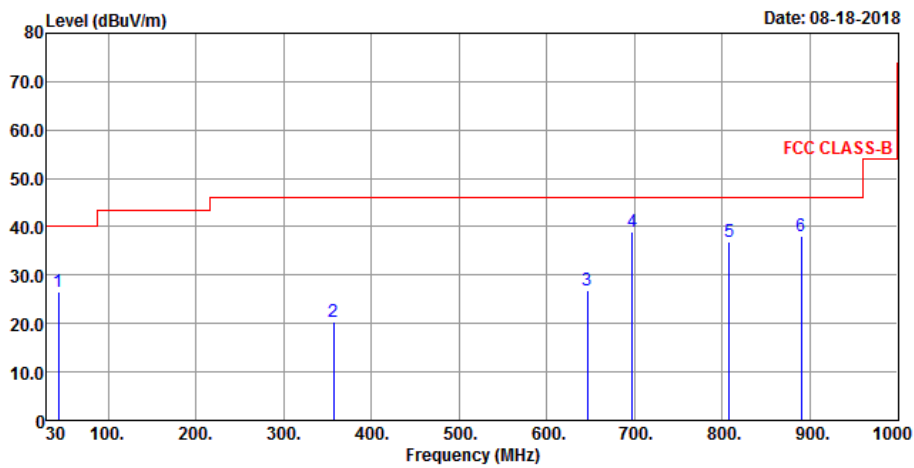

**Vertical**

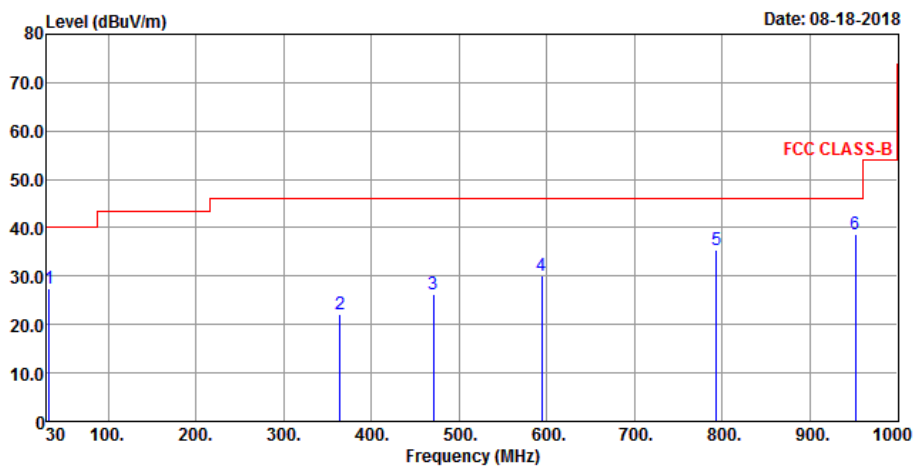

**Antenna Polarity & Test Distance: Horizontal at 3 m**

Frequency (MHz)	Emission Level (dBuV/m)	Read Level (dBuV)	Limit (dBuV/m)	Margin (dB)	Antenna Factor (dB/m)	Cable Loss (dB)	Preamp Factor (dB)	Antenna Height (cm)	Table Angle (Degree)	Remark
43.58	26.7	43.72	40	-13.3	13.59	0.5	31.11	288	329	Peak
356.89	20.25	35.96	46	-25.75	14.31	1.91	31.93	246	233	Peak
645.95	26.97	35.77	46	-19.03	20.16	3.09	32.05	219	188	Peak
697.36	38.98	46.7	46	-7.02	20.78	3.3	31.8	169	158	Peak
807.94	37	42.42	46	-9	22.33	3.7	31.45	132	109	Peak
890.39	38.22	42.83	46	-7.78	23.39	3.99	31.99	119	71	Peak

**Antenna Polarity & Test Distance: Vertical at 3 m**

Frequency (MHz)	Emission Level (dBuV/m)	Read Level (dBuV)	Limit (dBuV/m)	Margin (dB)	Antenna Factor (dB/m)	Cable Loss (dB)	Preamp Factor (dB)	Antenna Height (cm)	Table Angle (Degree)	Remark
32.91	27.33	45.49	40	-12.67	12.47	0.46	31.09	139	222	Peak
364.65	22.2	37.72	46	-23.8	14.49	1.94	31.95	155	78	Peak
470.38	26.4	39.19	46	-19.6	16.73	2.37	31.89	168	138	Peak
594.54	29.99	39.82	46	-16.01	19.48	2.88	32.19	189	191	Peak
793.39	35.3	40.94	46	-10.7	22.13	3.64	31.41	248	255	Peak
951.5	38.77	42.57	46	-7.23	23.8	4.24	31.84	294	311	Peak

**Remarks:**

- Emission Level = Read Level + Antenna Factor + Cable Loss - Preamp Factor  
Margin value = Emission level – Limit value
- The other emission levels were very low against the limit.

### Mode B

EUT Test Condition		Measurement Detail	
Channel	Channel 0	Frequency Range	30 MHz ~ 1 GHz
Input Power	120 Vac, 60 Hz	Detector Function	Peak (PK) Quasi-peak (QP)
Environmental Conditions	25 deg. C, 65 % RH	Tested By	Thomas Wei

### Horizontal

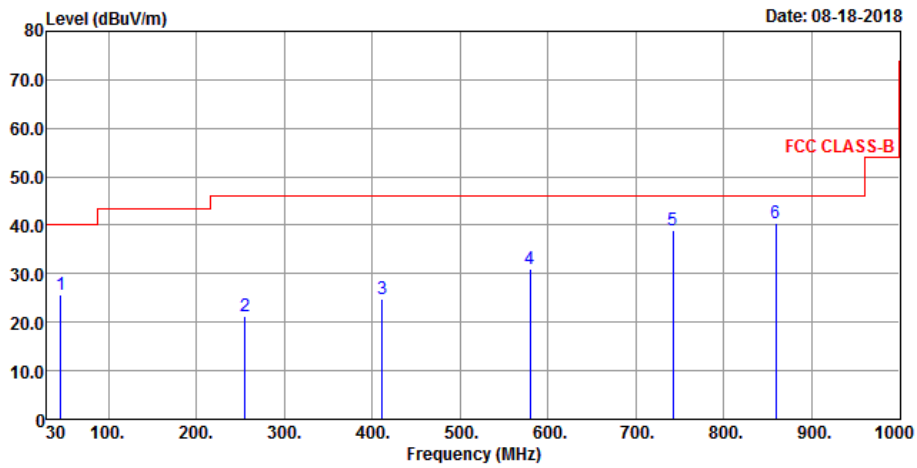

### Vertical

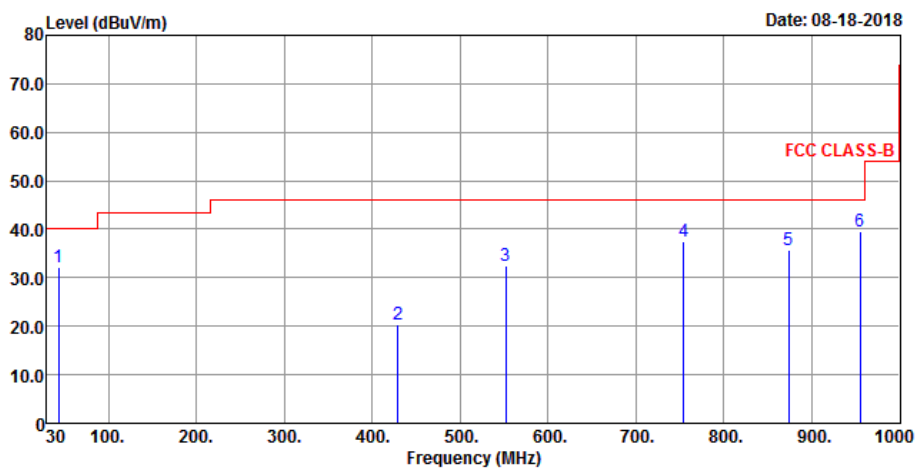



Antenna Polarity & Test Distance: Horizontal at 3 m										
Frequency (MHz)	Emission Level (dBuV/m)	Read Level (dBuV)	Limit (dBuV/m)	Margin (dB)	Antenna Factor (dB/m)	Cable Loss (dB)	Preamp Factor (dB)	Antenna Height (cm)	Table Angle (Degree)	Remark
45.52	25.65	42.8	40	-14.35	13.5	0.51	31.16	200	201	Peak
255.04	21.17	39.97	46	-24.83	11.62	1.48	31.9	159	66	Peak
411.21	24.79	39.11	46	-21.21	15.56	2.12	32	137	319	Peak
579.99	30.9	41.05	46	-15.1	19.15	2.82	32.12	269	114	Peak
741.98	39.01	45.56	46	-6.99	21.41	3.48	31.44	284	305	Peak
<b>859.35</b>	<b>40.56</b>	<b>45.58</b>	<b>46</b>	<b>-5.44</b>	<b>22.99</b>	<b>3.89</b>	<b>31.9</b>	<b>185</b>	<b>191</b>	<b>Peak</b>
Antenna Polarity & Test Distance: Vertical at 3 m										
Frequency (MHz)	Emission Level (dBuV/m)	Read Level (dBuV)	Limit (dBuV/m)	Margin (dB)	Antenna Factor (dB/m)	Cable Loss (dB)	Preamp Factor (dB)	Antenna Height (cm)	Table Angle (Degree)	Remark
43.58	32.06	49.08	40	-7.94	13.59	0.5	31.11	126	37	Peak
429.64	20.4	34.29	46	-25.6	15.93	2.19	32.01	155	109	Peak
551.86	32.6	43.37	46	-13.4	18.5	2.7	31.97	188	114	Peak
754.59	37.35	43.6	46	-8.65	21.59	3.53	31.37	244	191	Peak
873.9	35.63	40.51	46	-10.37	23.17	3.95	32	249	188	Peak
955.38	39.65	43.46	46	-6.35	23.82	4.25	31.88	277	311	Peak

Remarks:

1. Emission Level = Read Level + Antenna Factor + Cable Loss - Preamp Factor  
Margin value = Emission level – Limit value
2. The other emission levels were very low against the limit.

## 4.2 Conducted Emission Measurement

### 4.2.1 Limits of Conducted Emission Measurement

Frequency (MHz)	Conducted Limit (dBuV)	
	Quasi-Peak	Average
0.15 - 0.5	66 - 56	56 - 46
0.50 - 5.0	56	46
5.0 - 30.0	60	50

- Note: 1. The lower limit shall apply at the transition frequencies.  
 2. The limit decreases in line with the logarithm of the frequency in the range of 0.15 to 0.50 MHz.

### 4.2.2 Test Instruments

Description & Manufacturer	Model No.	Serial No.	Date of Calibration	Due Date of Calibration
Test Receiver ROHDE & SCHWARZ	ESCI	100613	Nov. 23, 2017	Nov. 22, 2018
RF signal cable Woken	5D-FB	Cable-cond1-01	Sep. 05, 2017	Sep. 04, 2018
LISN ROHDE & SCHWARZ (EUT)	ENV216	101826	Feb. 26, 2018	Feb. 25, 2019
LISN ROHDE & SCHWARZ (Peripheral)	ESH3-Z5	100311	Aug. 15, 2017	Aug. 14, 2018
Software ADT	BV ADT_Cond_ V7.3.7.4	NA	NA	NA

- Note: 1. The calibration interval of the above test instruments is 12 months and the calibrations are traceable to NML/ROC and NIST/USA.  
 2. The test was performed in HwaYa Shielded Room 1.  
 3. The VCCI Site Registration No. is C-2040.

#### 4.2.3 Test Procedures

- a. The EUT was placed 0.4 meters from the conducting wall of the shielded room with EUT being connected to the power mains through a line impedance stabilization network (LISN). Other support units were connected to the power mains through another LISN. The two LISNs provide 50 ohm/ 50 uH of coupling impedance for the measuring instrument.
- b. Both lines of the power mains connected to the EUT were checked for maximum conducted interference.
- c. The frequency range from 150 kHz to 30 MHz was searched. Emission levels under (Limit – 20 dB) was not recorded.

**Note:** The resolution bandwidth and video bandwidth of test receiver is 9 kHz for quasi-peak detection (QP) and average detection (AV) at frequency 0.15 MHz - 30 MHz.

#### 4.2.4 Deviation from Test Standard

No deviation.

#### 4.2.5 Test Setup

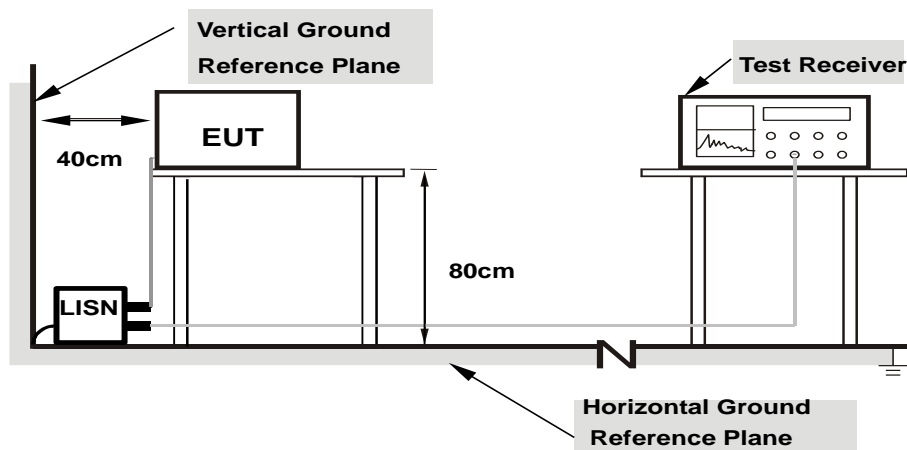

- Note:**
1. Support units were connected to second LISN.
  2. Both of LISNs (AMN) are 80 cm from EUT and at least 80 cm from other units and other metal planes

For the actual test configuration, please refer to the attached file (Test Setup Photo).

#### 4.2.6 EUT Operating Condition

Set the EUT under transmission condition continuously at specific channel frequency.

4.2.7 Test Results

**CONDUCTED WORST-CASE DATA : GFSK**

**Mode A**

Frequency Range	150kHz ~ 30MHz	Detector Function & Resolution Bandwidth	Quasi-Peak (QP) / Average (AV), 9kHz
Input Power	120Vac, 60Hz	Environmental Conditions	25°C, 65%RH
Tested by	Jisyong Wang	Test Date	2018/7/21

Phase Of Power : Line (L)										
No	Frequency (MHz)	Correction Factor (dB)	Reading Value (dBuV)		Emission Level (dBuV)		Limit (dBuV)		Margin (dB)	
			Q.P.	AV.	Q.P.	AV.	Q.P.	AV.	Q.P.	AV.
1	0.16955	9.67	28.98	13.79	38.65	23.46	64.98	54.98	-26.33	-31.52
2	0.23211	9.67	26.90	10.88	36.57	20.55	62.37	52.37	-25.80	-31.82
3	0.31031	9.67	25.11	9.86	34.78	19.53	59.96	49.96	-25.18	-30.43
4	0.59574	9.67	24.41	10.01	34.08	19.68	56.00	46.00	-21.92	-26.32
5	9.86244	9.87	20.30	5.04	30.17	14.91	60.00	50.00	-29.83	-35.09
6	16.00505	9.92	20.09	4.67	30.01	14.59	60.00	50.00	-29.99	-35.41

Remarks:

1. Q.P. and AV. are abbreviations of quasi-peak and average individually.
2. The emission levels of other frequencies were very low against the limit.
3. Margin value = Emission level – Limit value
4. Correction factor = Insertion loss + Cable loss
5. Emission Level = Correction Factor + Reading Value

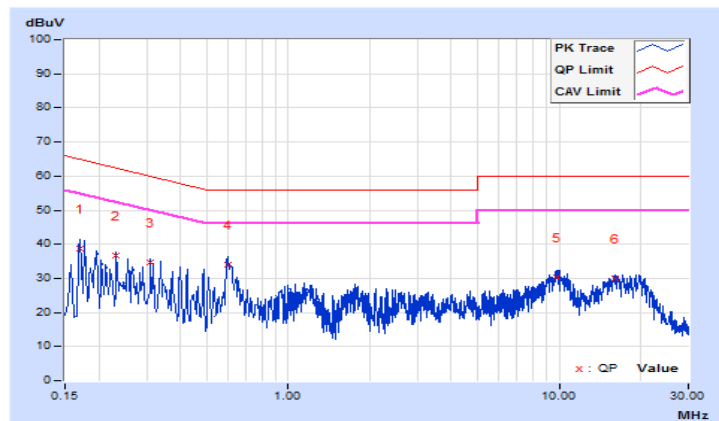

Frequency Range	150kHz ~ 30MHz	Detector Function & Resolution Bandwidth	Quasi-Peak (QP) / Average (AV), 9kHz
Input Power	120Vac, 60Hz	Environmental Conditions	25°C, 65%RH
Tested by	Jisyong Wang	Test Date	2018/7/21

Phase Of Power : Neutral (N)										
No	Frequency (MHz)	Correction Factor (dB)	Reading Value (dBuV)		Emission Level (dBuV)		Limit (dBuV)		Margin (dB)	
			Q.P.	AV.	Q.P.	AV.	Q.P.	AV.	Q.P.	AV.
1	0.15391	9.68	31.08	14.50	40.76	24.18	65.79	55.79	-25.03	-31.61
2	0.18075	9.68	26.89	12.48	36.57	22.16	64.45	54.45	-27.88	-32.29
3	0.32204	9.68	18.50	5.50	28.18	15.18	59.65	49.65	-31.47	-34.47
<b>4</b>	<b>0.59965</b>	<b>9.68</b>	<b>26.98</b>	<b>11.05</b>	<b>36.66</b>	<b>20.73</b>	<b>56.00</b>	<b>46.00</b>	<b>-19.34</b>	<b>-25.27</b>
5	9.60047	9.87	23.55	7.64	33.42	17.51	60.00	50.00	-26.58	-32.49
6	16.50553	9.99	21.67	3.00	31.66	12.99	60.00	50.00	-28.34	-37.01

Remarks:

1. Q.P. and AV. are abbreviations of quasi-peak and average individually.
2. The emission levels of other frequencies were very low against the limit.
3. Margin value = Emission level – Limit value
4. Correction factor = Insertion loss + Cable loss
5. Emission Level = Correction Factor + Reading Value

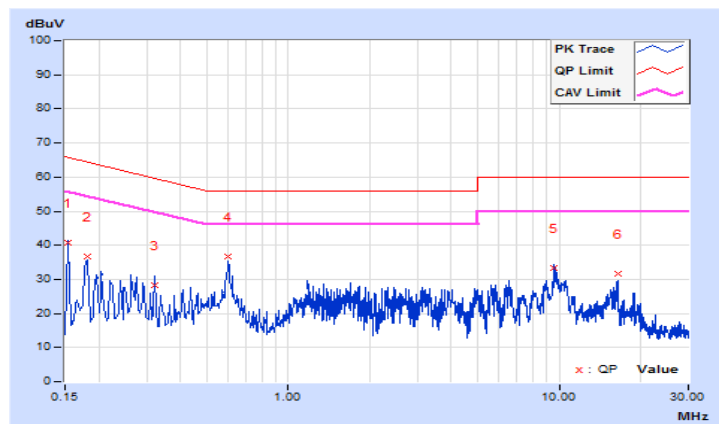

**Mode B**

Frequency Range	150kHz ~ 30MHz	Detector Function & Resolution Bandwidth	Quasi-Peak (QP) / Average (AV), 9kHz
Input Power	120Vac, 60Hz	Environmental Conditions	25°C, 65%RH
Tested by	Jisyong Wang	Test Date	2018/7/21

Phase Of Power : Line (L)										
No	Frequency (MHz)	Correction Factor (dB)	Reading Value (dBuV)		Emission Level (dBuV)		Limit (dBuV)		Margin (dB)	
			Q.P.	AV.	Q.P.	AV.	Q.P.	AV.	Q.P.	AV.
1	0.18128	9.67	27.43	11.43	37.10	21.10	64.43	54.43	-27.33	-33.33
2	0.20674	9.67	26.74	12.47	36.41	22.14	63.34	53.34	-26.93	-31.20
3	0.23216	9.67	26.29	12.67	35.96	22.34	62.37	52.37	-26.41	-30.03
4	0.60356	9.67	22.81	8.36	32.48	18.03	56.00	46.00	-23.52	-27.97
5	1.18224	9.69	19.62	6.59	29.31	16.28	56.00	46.00	-26.69	-29.72
6	11.28959	9.88	19.65	1.42	29.53	11.30	60.00	50.00	-30.47	-38.70

Remarks:

1. Q.P. and AV. are abbreviations of quasi-peak and average individually.
2. The emission levels of other frequencies were very low against the limit.
3. Margin value = Emission level – Limit value
4. Correction factor = Insertion loss + Cable loss
5. Emission Level = Correction Factor + Reading Value

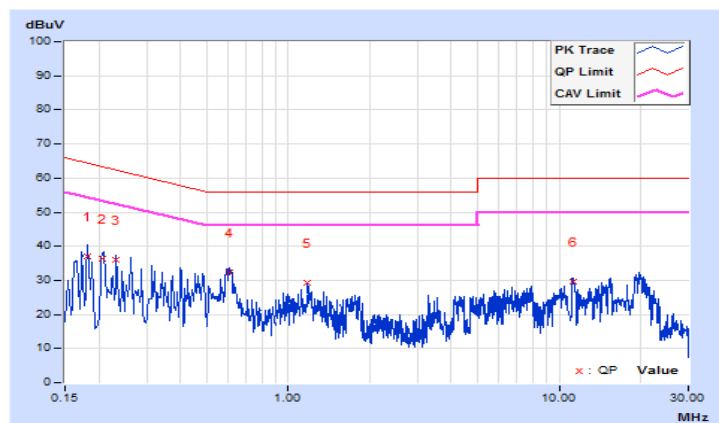

Frequency Range	150kHz ~ 30MHz	Detector Function & Resolution Bandwidth	Quasi-Peak (QP) / Average (AV), 9kHz
Input Power	120Vac, 60Hz	Environmental Conditions	25°C, 65%RH
Tested by	Jisyong Wang	Test Date	2018/7/21

Phase Of Power : Neutral (N)										
No	Frequency (MHz)	Correction Factor (dB)	Reading Value (dBuV)		Emission Level (dBuV)		Limit (dBuV)		Margin (dB)	
			Q.P.	AV.	Q.P.	AV.	Q.P.	AV.	Q.P.	AV.
1	0.17346	9.68	26.93	8.85	36.61	18.53	64.79	54.79	-28.18	-36.26
2	0.23211	9.68	24.74	7.59	34.42	17.27	62.37	52.37	-27.95	-35.10
3	0.31765	9.68	26.00	10.60	35.68	20.28	59.77	49.77	-24.09	-29.49
4	0.61138	9.68	26.55	12.67	36.23	22.35	56.00	46.00	-19.77	-23.65
5	9.55746	9.87	23.64	9.04	33.51	18.91	60.00	50.00	-26.49	-31.09
6	15.52803	9.98	19.56	4.51	29.54	14.49	60.00	50.00	-30.46	-35.51

Remarks:

1. Q.P. and AV. are abbreviations of quasi-peak and average individually.
2. The emission levels of other frequencies were very low against the limit.
3. Margin value = Emission level – Limit value
4. Correction factor = Insertion loss + Cable loss
5. Emission Level = Correction Factor + Reading Value

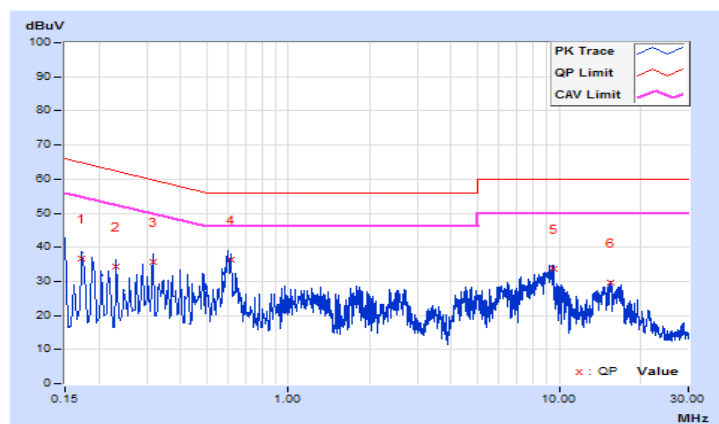

### 4.3 Number of Hopping Frequency Used

#### 4.3.1 Limits of Hopping Frequency Used Measurement

At least 15 channels frequencies, and should be equally spaced.

#### 4.3.2 Test Setup

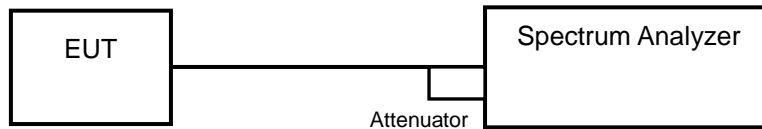

#### 4.3.3 Test Instruments

Refer to section 4.1.2 to get information of above instrument.

#### 4.3.4 Test Procedure

- Check the calibration of the measuring instrument (SA) using either an internal calibrator or a known signal from an external generator.
- Turn on the EUT and connect its antenna terminal to measurement via a low loss cable. Then set it to any one measured frequency within its operating range and make sure the instrument is operated in its linear range.
- Set the SA on MaxHold Mode, and then keep the EUT in hopping mode. Record all the signals from each channel until each one has been recorded.
- Set the SA on View mode and then plot the result on SA screen.
- Repeat above procedures until all frequencies measured were complete.

#### 4.3.5 Deviation from Test Standard

No deviation.



### 4.3.6 Test Results

There are 79 hopping frequencies in the hopping mode and 20 hopping frequencies in the AFH mode. Please refer to next page for the test result. On the plots, it shows that the hopping frequencies are equally spaced.

Number of Hopping (Channel)	Adaptive Frequency Hopping (Channel)	Limit	Pass / Fail
79	20	> 15	Pass

#### <GFSK>

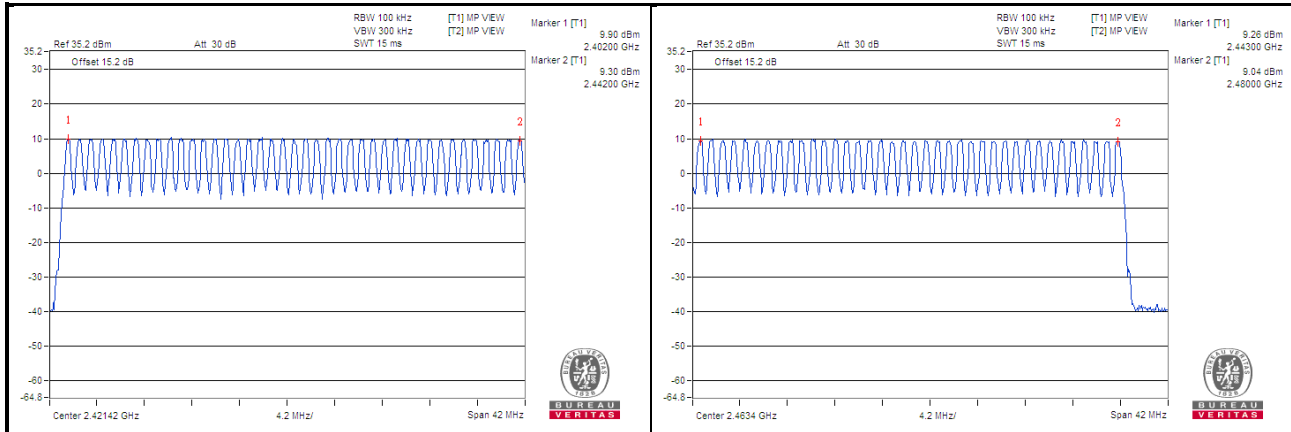

#### <8DPSK>

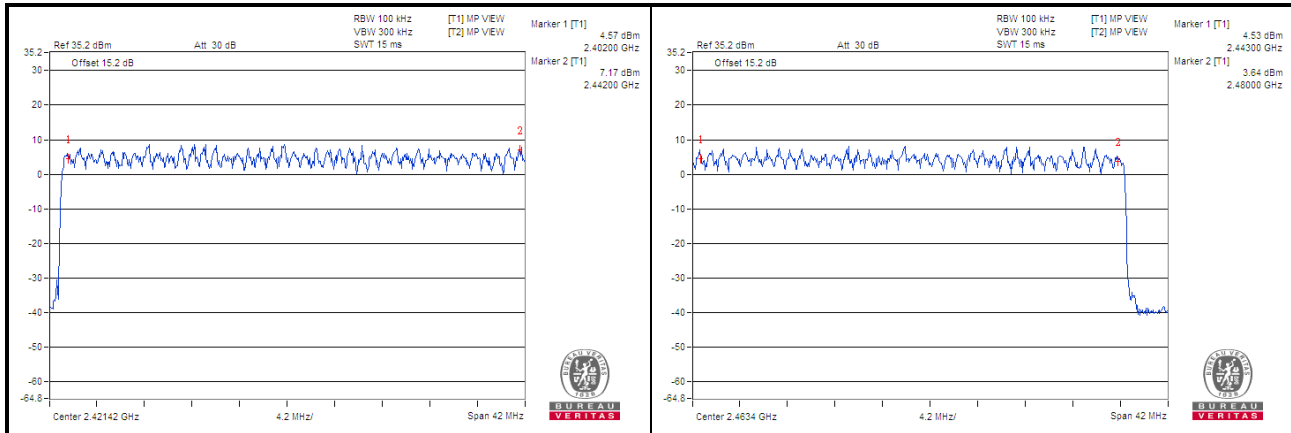

#### 4.4 Dwell Time on Each Channel

##### 4.4.1 Limits of Dwell Time on Each Channel Measurement

The average time of occupancy on any channel shall not be greater than 0.4 seconds within a period of 0.4 seconds multiplied by the number of hopping channels employed.

##### 4.4.2 Test Setup

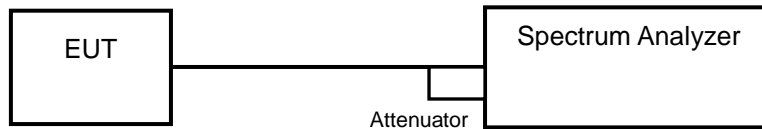

##### 4.4.3 Test Instruments

Refer to section 4.1.2 to get information of above instrument.

##### 4.4.4 Test Procedures

- a. Check the calibration of the measuring instrument (SA) using either an internal calibrator or a known signal from an external generator.
- b. Turn on the EUT and connect its antenna terminal to measurement via a low loss cable. Then set it to any one measured frequency within its operating range and make sure the instrument is operated in its linear range.
- c. Adjust the center frequency of SA on any frequency be measured and set SA to zero span mode. And then, set RBW and VBW of spectrum analyzer to proper value.
- d. Measure the time duration of one transmission on the measured frequency. And then plot the result with time difference of this time duration.
- e. Repeat above procedures until all different time-slot modes have been completed.

##### 4.4.5 Deviation from Test Standard

No deviation.

### 4.4.6 Test Results

#### GFSK

Mode	Number of Transmission in a 31.6 (79 Hopping*0.4)	Length of Transmission Time (msec)	Result (msec)	Limit (sec)
DH1	51 (times / 5 sec) * 6.32 = 322.32 times	0.45	145	0.4
DH3	25 (times / 5 sec) * 6.32 = 158 times	1.7	268.6	0.4
DH5	17 (times / 5 sec) * 6.32 = 107.44 times	2.98	320.2	0.4

**Note:** Test plots of the transmitting time slot are shown as below.



### 8DPSK

Mode	Number of Transmission in a 31.6 (79 Hopping*0.4)	Length of Transmission Time (msec)	Result (msec)	Limit (sec)
3DH1	50 (times / 5 sec) * 6.32 = 316 times	0.456	144.1	0.4
3DH3	26 (times / 5 sec) * 6.32 = 164.32 times	1.7	279.3	0.4
3DH5	18 (times / 5 sec) * 6.32 = 113.76 times	3	341.3	0.4

**Note:** Test plots of the transmitting time slot are shown as below.



### AFH Mode

Mode	Number of Transmission in a 31.6 (79 Hopping*0.4)	Length of Transmission Time (msec)	Result (msec)	Limit (sec)
DH1	50 (times / 5 sec) * 6.32 = 316 times	0.445	140.6	0.4
DH3	26 (times / 5 sec) * 6.32 = 164.32 times	1.695	278.5	0.4
DH5	17 (times / 5 sec) * 6.32 = 107.44 times	2.93	314.8	0.4

**Note:** Test plots of the transmitting time slot are shown as below.

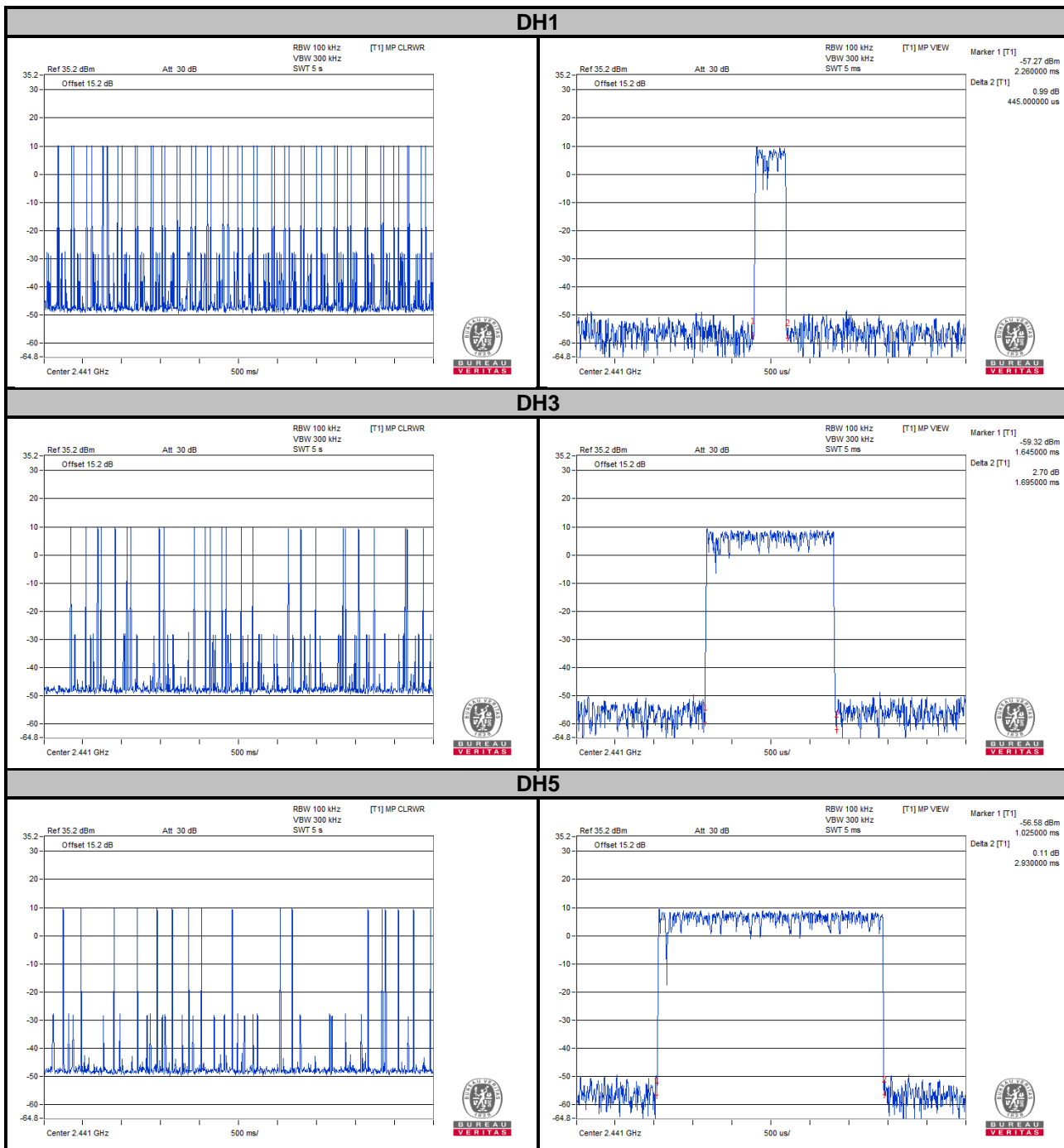

## 4.5 Channel Bandwidth

### 4.5.1 Limits of Channel Bandwidth Measurement

For frequency hopping system operating in the 2400-2483.5 MHz, if the 20 dB bandwidth of hopping channel is greater than 25 kHz, two-thirds 20 dB bandwidth of hopping channel shall be a minimum limit for the hopping channel separation.

### 4.5.2 Test Setup

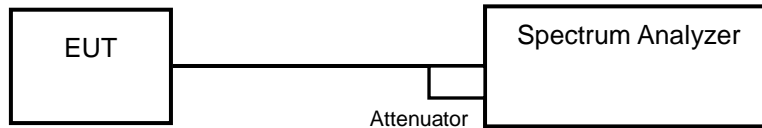

### 4.5.3 Test Instruments

Refer to section 4.1.2 to get information of above instrument.

### 4.5.4 Test Procedure

- a. Check the calibration of the measuring instrument using either an internal calibrator or a known signal from an external generator.
- b. Turn on the EUT and connect it to measurement instrument. Then set it to any one convenient frequency within its operating range. Set a reference level on the measuring instrument equal to the highest peak value.
- c. Measure the frequency difference of two frequencies that were attenuated 20 dB from the reference level. Record the frequency difference as the emission bandwidth.
- d. Repeat above procedures until all frequencies measured were complete.

### 4.5.5 Deviation from Test Standard

No deviation.

### 4.5.6 EUT Operating Condition

The software provided by client enabled the EUT to transmit and receive data at lowest, middle and highest channel frequencies individually.

#### 4.5.7 Test Results

Channel	Frequency (MHz)	20 dB Bandwidth (MHz)	
		GFSK	8DPSK
0	2402	0.98	1.31
39	2441	0.99	1.31
78	2480	0.99	1.31

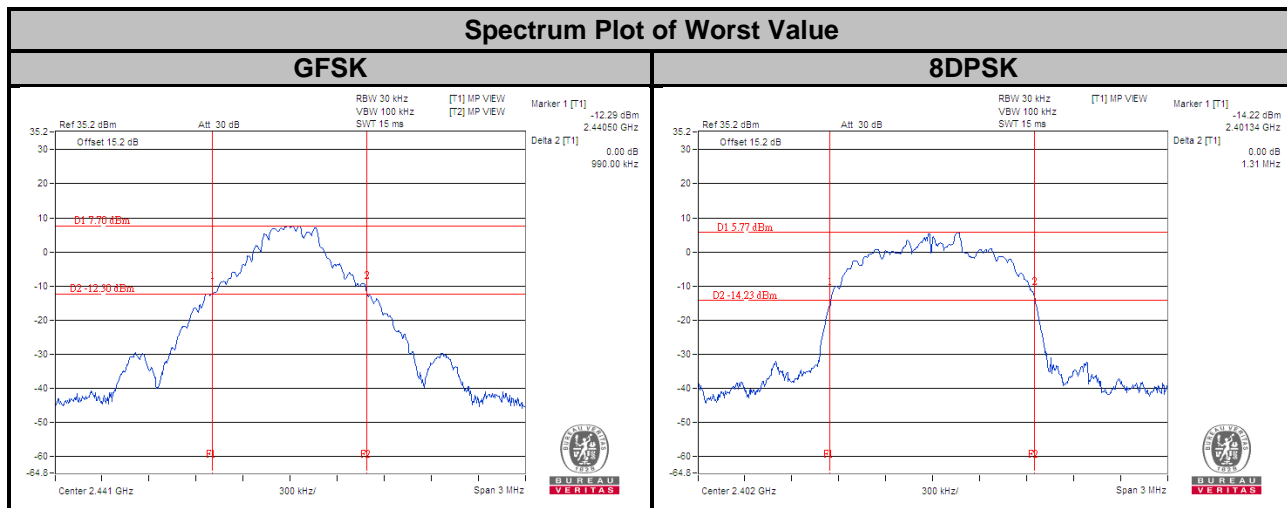

## 4.6 Occupied Bandwidth Measurement

### 4.6.1 Test Setup

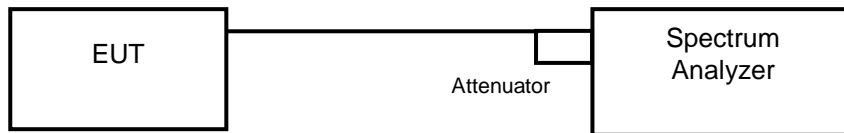

### 4.6.2 Test Instruments

Refer to section 4.1.2 to get information of above instrument

### 4.6.3 Test Procedure

The transmitter output was connected to the spectrum analyzer through an attenuator. The bandwidth of the fundamental frequency was measured by spectrum analyzer with resolution bandwidth in the range of 1 % to 5 % of the anticipated emission bandwidth, and a video bandwidth at least 3x the resolution bandwidth and set the detector to PEAK. The width of a frequency band such that, below the lower and above the upper frequency limits, the mean powers emitted are each equal to a specified percentage 0.5 % of the total mean power of a given emission.

### 4.6.4 Deviation from Test Standard

No deviation.

### 4.6.5 EUT Operating Conditions

The software provided by client to enable the EUT under transmission condition continuously at lowest, middle and highest channel frequencies individually.



#### 4.6.6 Test Results

Channel	Frequency (MHz)	Occupied Bandwidth (MHz)	
		GFSK	8DPSK
0	2402	0.90	1.18
39	2441	0.91	1.18
78	2480	0.90	1.18

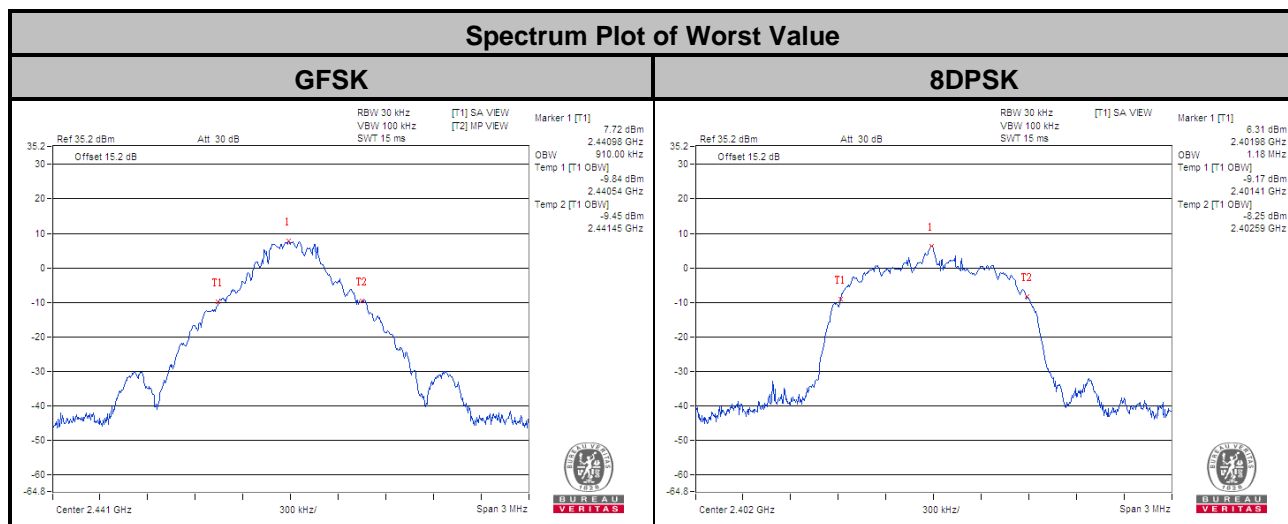

## 4.7 Hopping Channel Separation

### 4.7.1 Limits of Hopping Channel Separation Measurement

At least 25 kHz or two-third of 20 dB hopping channel bandwidth (whichever is greater).

### 4.7.2 Test Setup



### 4.7.3 Test Instruments

Refer to section 4.1.2 to get information of above instrument.

### 4.7.4 Test Procedure

#### Measurement Procedure REF

- Check the calibration of the measuring instrument using either an internal calibrator or a known signal from an external generator.
- Turn on the EUT and connect it to measurement instrument. Then set it to any one convenient frequency within its operating range.
- By using the MaxHold function record the separation of two adjacent channels.
- Measure the frequency difference of these two adjacent channels by SA MARK function. And then plot the result on SA screen.
- Repeat above procedures until all frequencies measured were complete.

### 4.7.5 Deviation from Test Standard

No deviation.

#### 4.7.6 Test Results

Channel	Freq. (MHz)	Adjacent Channel Separation (MHz)		20 dB Bandwidth (MHz)		Minimum Limit (MHz)		Pass / Fail
		GFSK	8DPSK	GFSK	8DPSK	GFSK	8DPSK	
0	2402	1.00	1.00	0.98	1.31	0.66	0.88	Pass
39	2441	1.00	1.00	0.99	1.31	0.66	0.88	Pass
78	2480	1.00	1.00	0.99	1.31	0.66	0.88	Pass

**Note:**

- The minimum limit is two-third 20 dB bandwidth.

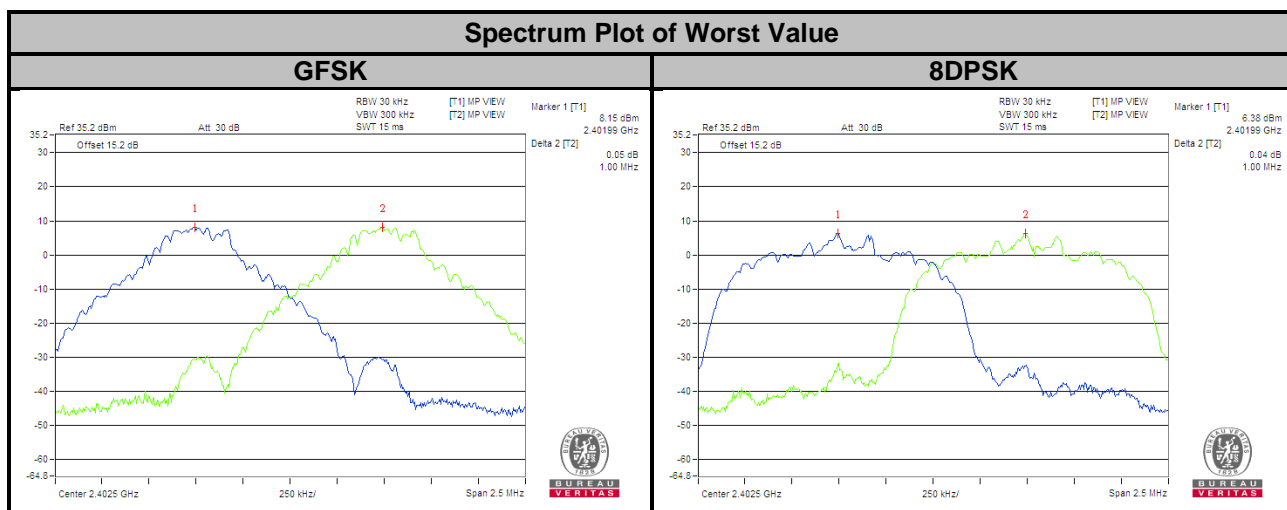

## 4.8 Maximum Output Power

### 4.8.1 Limits of Maximum Output Power Measurement

The Maximum Output Power Measurement is 125 mW.

### 4.8.2 Test Setup

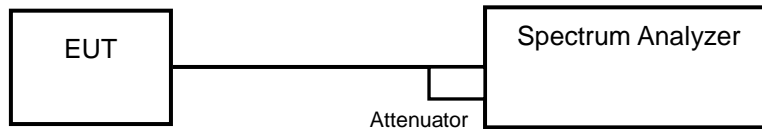

### 4.8.3 Test Instruments

Refer to section 4.1.2 to get information of above instrument.

### 4.8.4 Test Procedure

- Check the calibration of the measuring instrument using either an internal calibrator or a known signal from an external generator.
- Turn on the EUT and connect it to measurement instrument. Then set it to any one convenient frequency within its operating range. Set a reference level on the measuring instrument equal to the highest peak value.
- The center frequency of the spectrum analyzer is set to the fundamental frequency and using 3 MHz RBW and 10 MHz VBW.
- Measure the captured power within the band and recording the plot.
- Repeat above procedures until all frequencies required were complete.

### 4.8.5 Deviation from Test Standard

No deviation.

### 4.8.6 EUT Operating Condition

The software provided by client enabled the EUT to transmit and receive data at lowest, middle and highest channel frequencies individually.

#### 4.8.7 Test Results

##### <GFSK>

Channel	Freq. (MHz)	Output Power (mW)	Output Power (dBm)	Power Limit (mW)	Pass / Fail
0	2402	12.445	10.95	125	Pass
39	2441	11.508	10.61	125	Pass
78	2480	10.351	10.15	125	Pass

##### <8DPSK>

Channel	Freq. (MHz)	Output Power (mW)	Output Power (dBm)	Power Limit (mW)	Pass / Fail
0	2402	13.366	11.26	125	Pass
39	2441	12.417	10.94	125	Pass
78	2480	11.22	10.50	125	Pass

#### Spectrum Plot of Worst Value

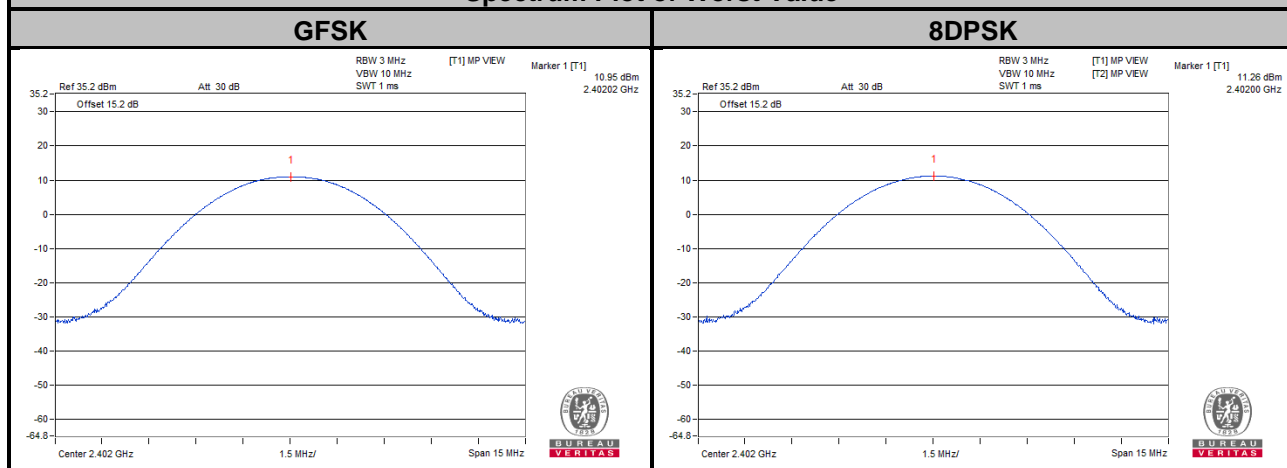

## 4.9 Conducted Out of Band Emission Measurement

### 4.9.1 Limits Of Conducted Out of Band Emission Measurement

Below  $-20$  dB of the highest emission level of operating band (in 100 kHz RBW).

### 4.9.2 Test Instruments

Refer to section 4.1.2 to get information of above instrument.

### 4.9.3 Test Procedure

The transmitter output was connected to the spectrum analyzer via a low lose cable. Set both RBW and VBW of spectrum analyzer to 100 kHz and 300 kHz with suitable frequency span including 100 MHz bandwidth from band edge. The band edges was measured and recorded.

### 4.9.4 Deviation from Test Standard

No deviation.

### 4.9.5 EUT Operating Condition

The software provided by client enabled the EUT to transmit and receive data at lowest, middle and highest channel frequencies individually.

### 4.9.6 Test Results

The spectrum plots are attached on the following images. D1 line indicates the highest level, D2 line indicates the 20 dB offset below D1. It shows compliance with the requirement.

GFSK

Hopping Disabled\_Low Channel

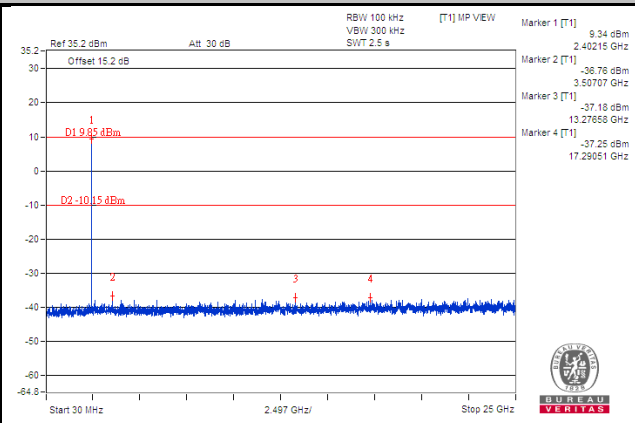
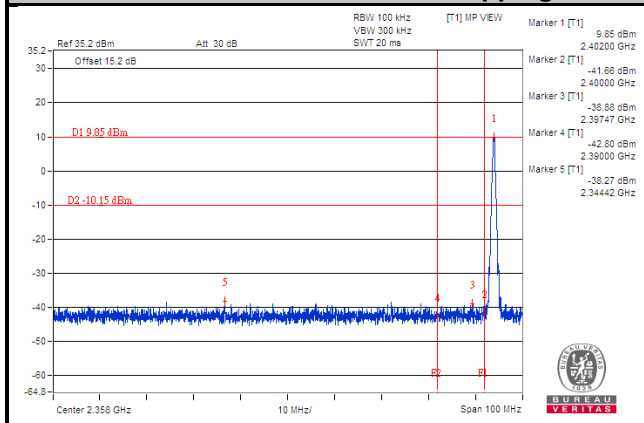

Hopping Disabled\_Middle Channel

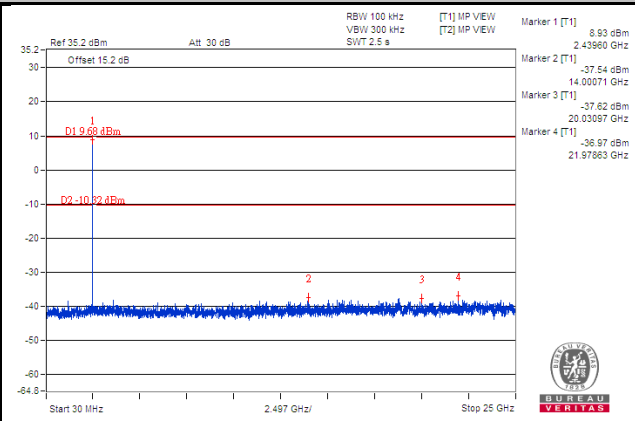
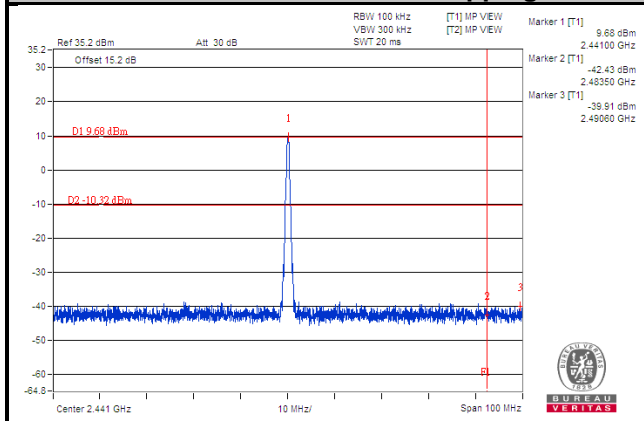

Hopping Disabled\_High Channel

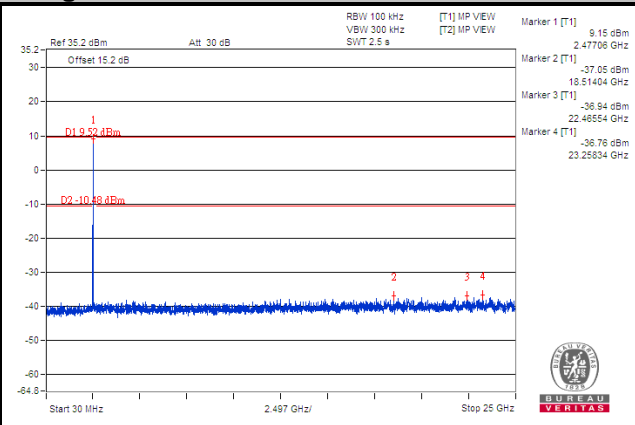
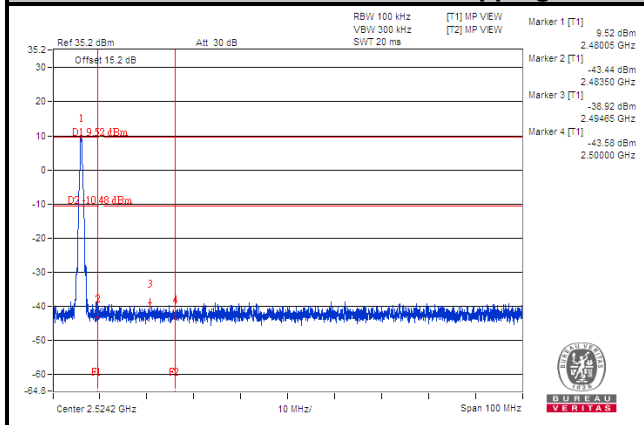

### Hopping Enabled\_Low Channel

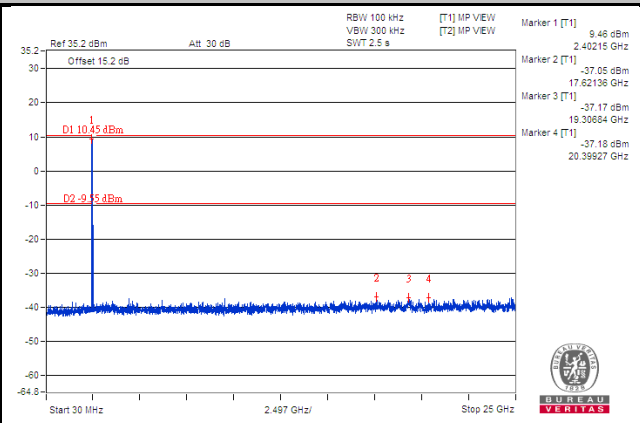
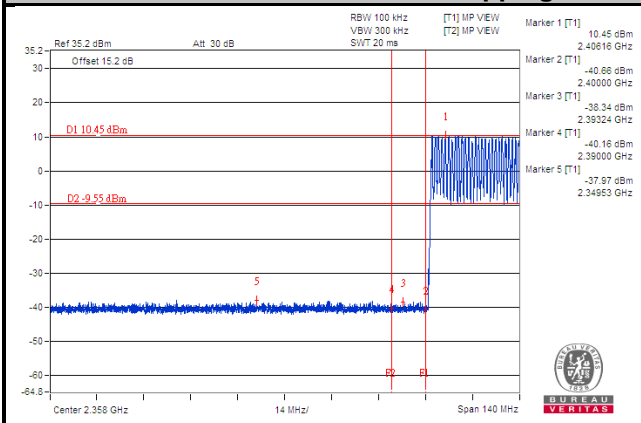

### Hopping Enabled\_High Channel

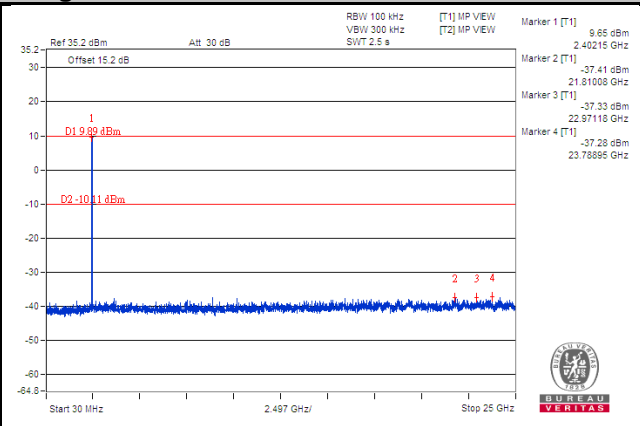
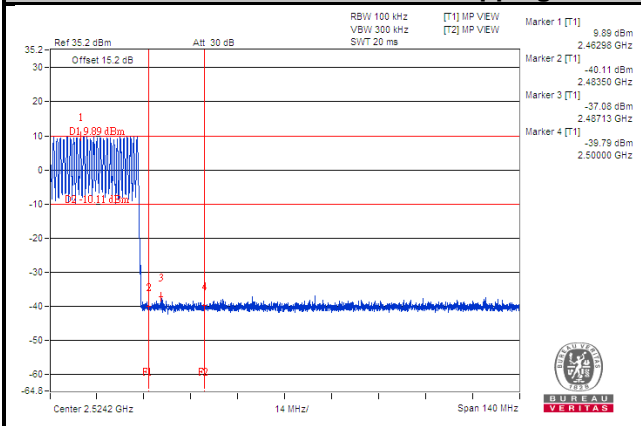



# 8DPSK

## Hopping Disabled\_Low Channel

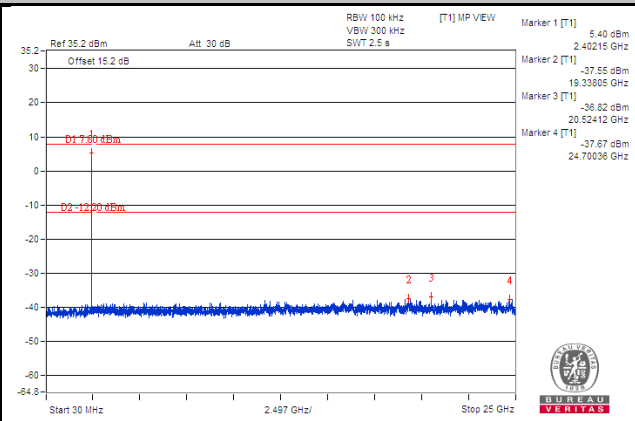
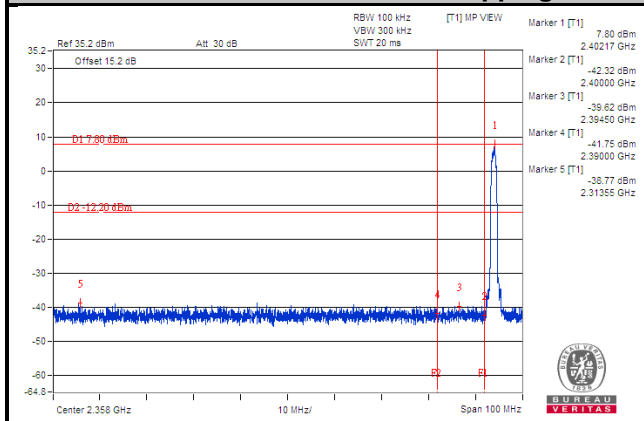

## Hopping Disabled\_Middle Channel

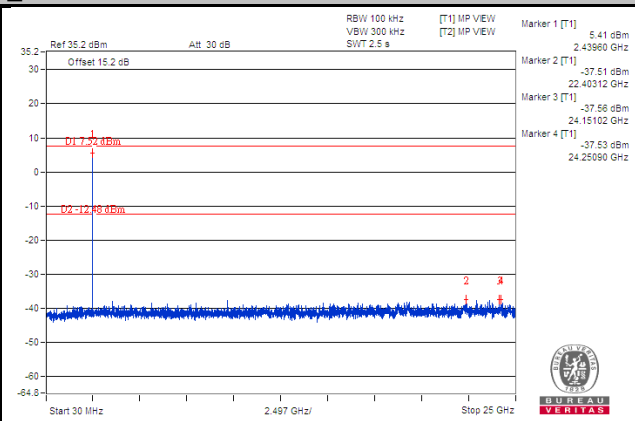
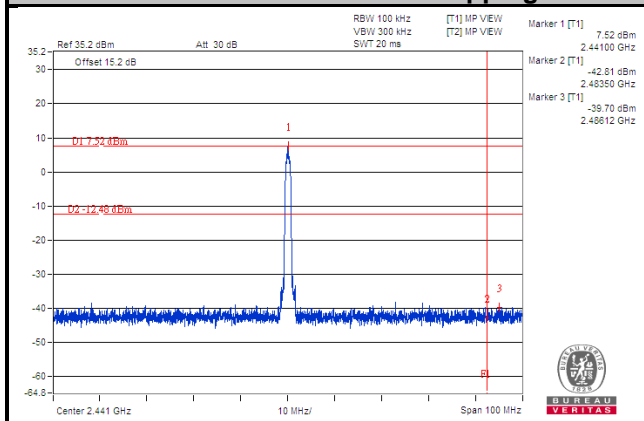

## Hopping Disabled\_High Channel

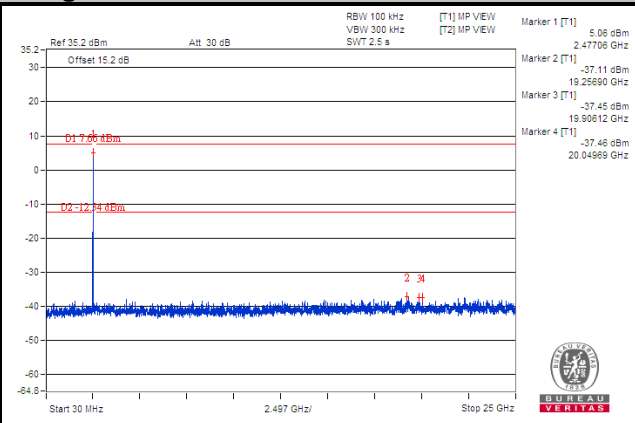
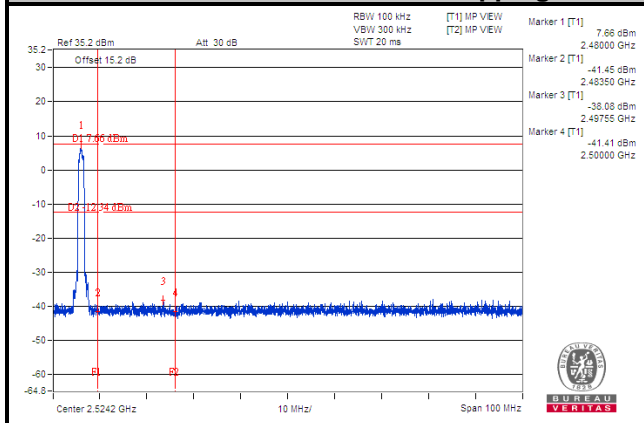

### Hopping Enabled\_Low Channel

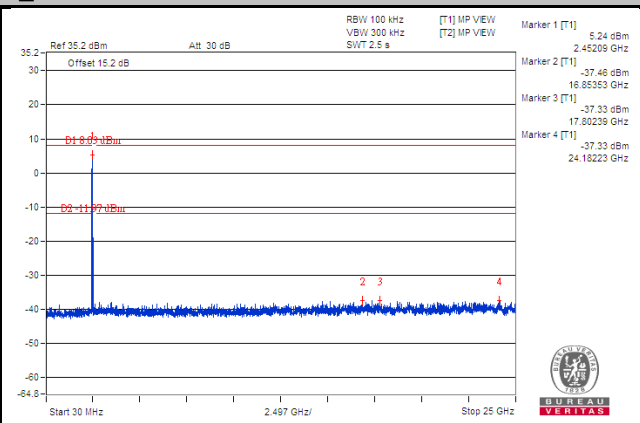
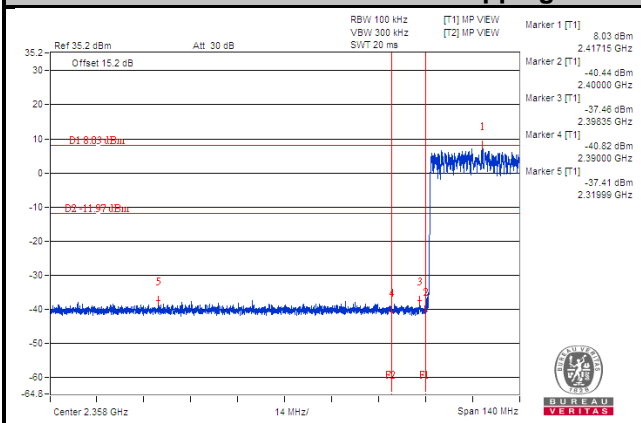

### Hopping Enabled\_High Channel

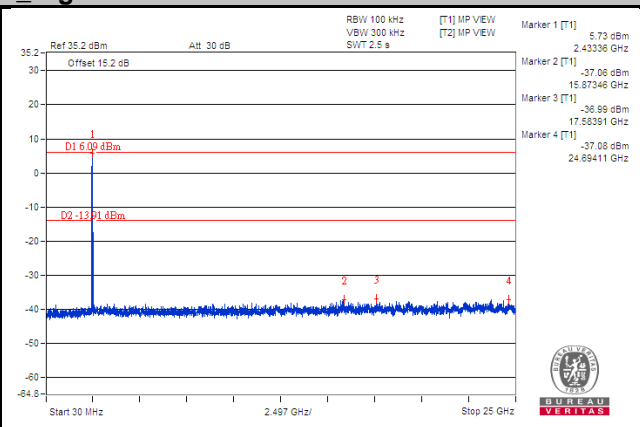
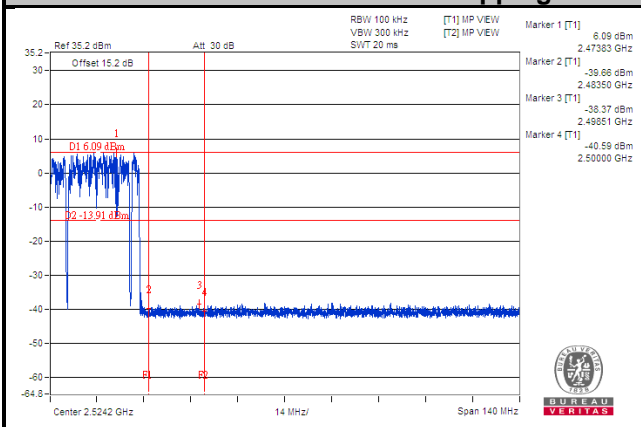

## <BLUETOOTH LE>

### 4.10 Radiated Emission and Bandedge Measurement

#### 4.10.1 Limits of Radiated Emission and Bandedge Measurement

Radiated emissions which fall in the restricted bands must comply with the radiated emission limits specified as below table. Other emissions shall be at least 20 dB below the highest level of the desired power:

Frequencies (MHz)	Field Strength (microvolts/meter)	Measurement Distance (meters)
0.009 ~ 0.490	2400/F (kHz)	300
0.490 ~ 1.705	24000/F (kHz)	30
1.705 ~ 30.0	30	30
30 ~ 88	100	3
88 ~ 216	150	3
216 ~ 960	200	3
Above 960	500	3

#### Note:

1. The lower limit shall apply at the transition frequencies.
2. Emission level (dBuV/m) = 20 log Emission level (uV/m).
3. For frequencies above 1000 MHz, the field strength limits are based on average detector, however, the peak field strength of any emission shall not exceed the maximum permitted average limits, specified above by more than 20 dB under any condition of modulation.

#### 4.10.2 Test Instruments

Refer to section 4.1.2 to get information of the instrument.

#### 4.10.3 Test Procedures

##### **For Radiated Emission below 30 MHz**

- a. The EUT was placed on the top of a rotating table 0.8 meters above the ground at a 3 meter chamber room. The table was rotated 360 degrees to determine the position of the highest radiation.
- b. The EUT was set 3 meters away from the interference-receiving antenna, which was mounted on the top of a variable-height antenna tower.
- c. Parallel, perpendicular, and ground-parallel orientations of the antenna are set to make the measurement.
- d. For each suspected emission, the EUT was arranged to its worst case and the rotatable table was turned from 0 degrees to 360 degrees to find the maximum reading.
- e. The test-receiver system was set to Quasi-Peak Detect Function and Specified Bandwidth with Maximum Hold Mode.

##### **Note:**

1. The resolution bandwidth and video bandwidth of test receiver/spectrum analyzer is 9 kHz at frequency below 30 MHz.
2. There is a comparison data of both open-field test site and semi-Anechoic chamber, and the result came out very similar.

##### **For Radiated Emission above 30 MHz**

- a. The EUT was placed on the top of a rotating table 0.8 meters (for 30 MHz ~ 1 GHz) / 1.5 meters (for above 1 GHz) above the ground at 3 meter chamber room for test. The table was rotated 360 degrees to determine the position of the highest radiation.
- b. The EUT was set 3 meters away from the interference-receiving antenna, which was mounted on the top of a variable-height antenna tower.
- c. The height of antenna is varied from one meter to four meters above the ground to determine the maximum value of the field strength. Both horizontal and vertical polarizations of the antenna are set to make the measurement.
- d. For each suspected emission, the EUT was arranged to its worst case and then the antenna was tuned to heights from 1 meter to 4 meters and the rotatable table was turned from 0 degrees to 360 degrees to find the maximum reading.
- e. The test-receiver system was set to quasi-peak detect function and specified bandwidth with maximum hold mode when the test frequency is below 1 GHz.
- f. The test-receiver system was set to peak and average detected function and specified bandwidth with maximum hold mode when the test frequency is above 1 GHz. If the peak reading value also meets average limit, measurement with the average detector is unnecessary.

##### **Note:**

1. The resolution bandwidth and video bandwidth of test receiver/spectrum analyzer is 120 kHz for Quasi-peak detection (QP) at frequency below 1 GHz.
2. The resolution bandwidth of test receiver/spectrum analyzer is 1 MHz and the video bandwidth is 3 MHz for Peak detection (PK) at frequency above 1 GHz.
3. The resolution bandwidth of test receiver/spectrum analyzer is 1 MHz and the video bandwidth is  $\geq 1/T$  (Duty cycle < 98 %) or 10 Hz (Duty cycle  $\geq 98$  %) for Average detection (AV) at frequency above 1 GHz. (RBW = 1 MHz, VBW = 3 kHz)
4. All modes of operation were investigated and the worst-case emissions are reported.

4.10.4 Deviation from Test Standard

No deviation.

4.10.5 Test Set Up

<Radiated Emission below 30 MHz>

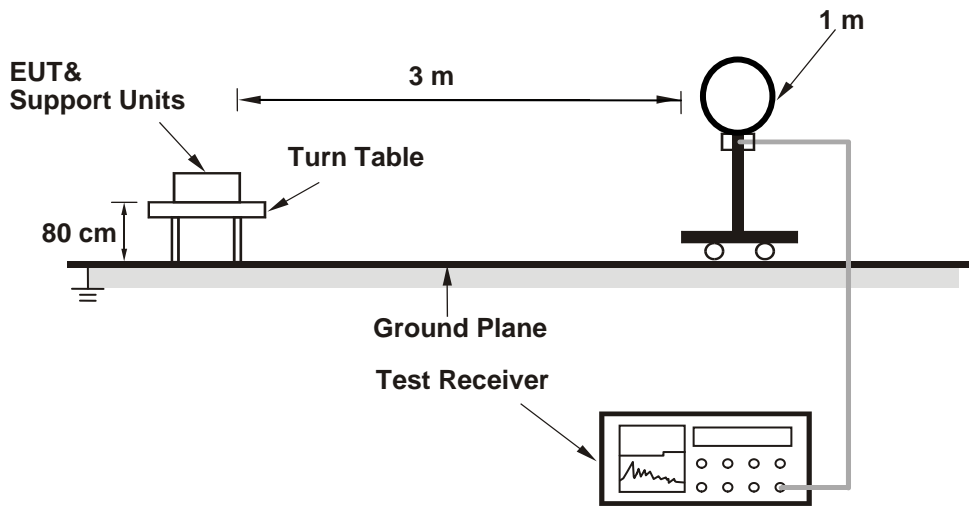

<Radiated Emission 30 MHz to 1 GHz>

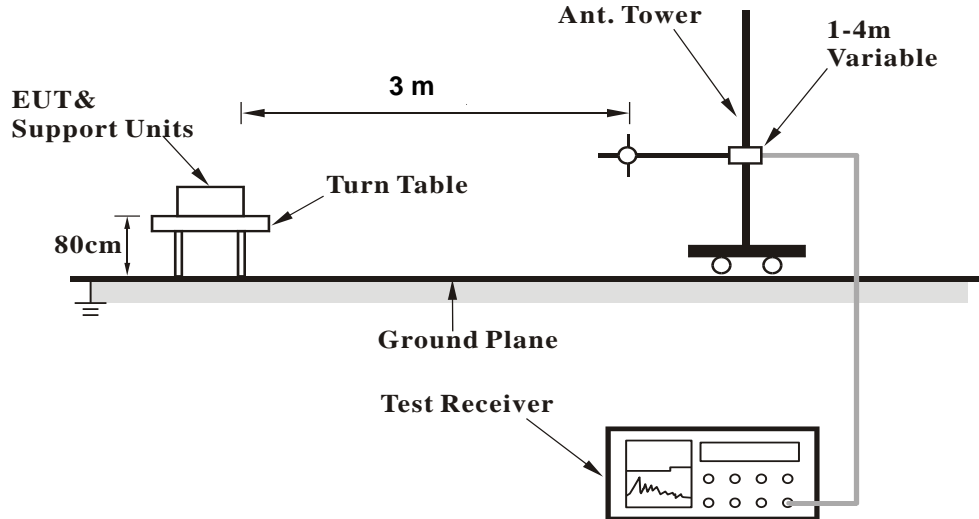

### <Radiated Emission above 1 GHz>

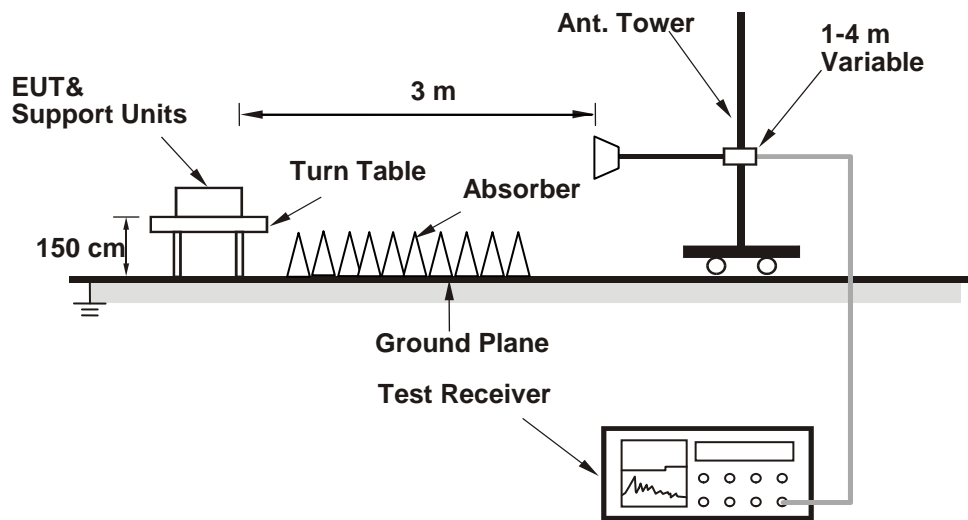

For the actual test configuration, please refer to the attached file (Test Setup Photo).

#### 4.10.6 EUT Operating Conditions

- a. Placed the EUT on the testing table.
- b. Set the EUT under transmission condition continuously at specific channel frequency.

#### 4.10.7 Test Results

#### Above 1 GHz Data:

#### Mode A

EUT Test Condition		Measurement Detail	
Channel	Channel 0	Frequency Range	1 GHz ~ 25 GHz
Input Power	120 Vac, 60 Hz	Detector Function	Peak (PK) Average (AV)
Environmental Conditions	25 deg. C, 65 % RH	Tested By	Thomas Wei

#### Horizontal

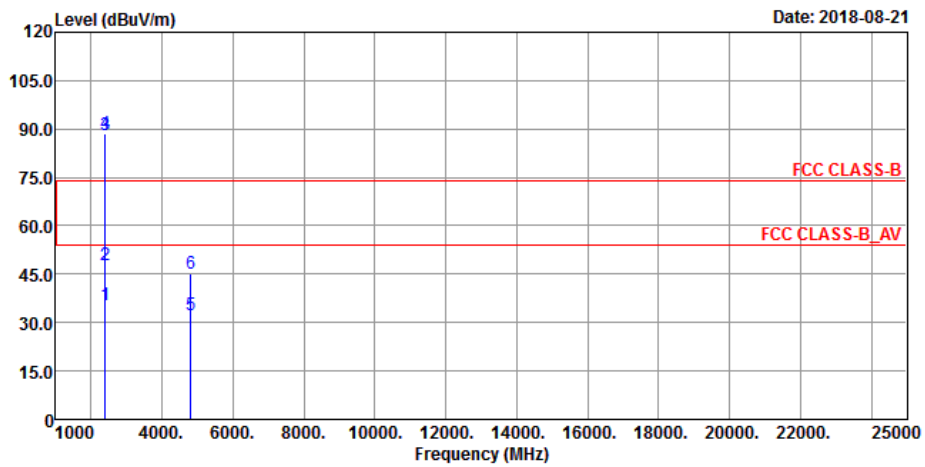

#### Vertical

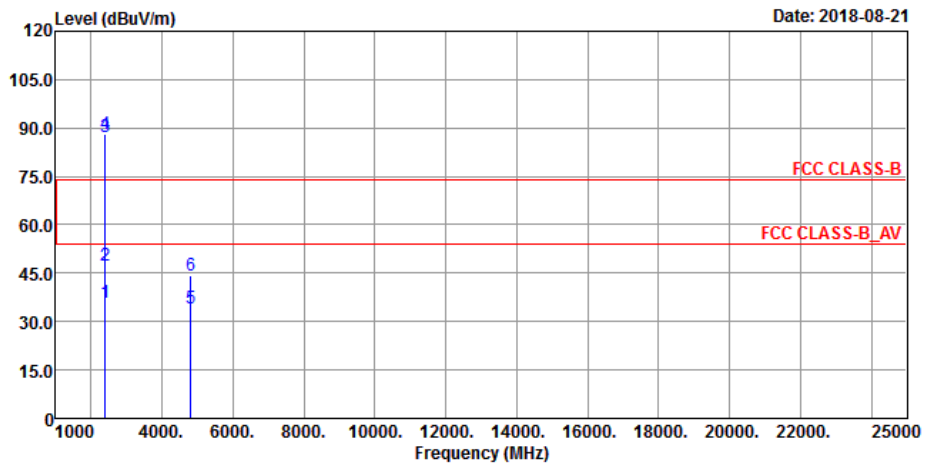

Antenna Polarity & Test Distance: Horizontal at 3 m										
Frequency (MHz)	Emission Level (dBuV/m)	Read Level (dBuV)	Limit (dBuV/m)	Margin (dB)	Antenna Factor (dB/m)	Cable Loss (dB)	Preamp Factor (dB)	Antenna Height (cm)	Table Angle (Degree)	Remark
2388.56	35.44	41.51	54	-18.56	27.08	4.35	37.5	132	261	Average
2388.56	47.73	53.8	74	-26.27	27.08	4.35	37.5	132	261	Peak
2402	87.93	93.92			27.16	4.37	37.52	132	261	Average
2402	88.66	94.65			27.16	4.37	37.52	132	261	Peak
4804	32.19	47.88	54	-21.81	31.14	6.07	52.9	155	301	Average
4804	45.2	60.89	74	-28.8	31.14	6.07	52.9	155	301	Peak
Antenna Polarity & Test Distance: Vertical at 3 m										
Frequency (MHz)	Emission Level (dBuV/m)	Read Level (dBuV)	Limit (dBuV/m)	Margin (dB)	Antenna Factor (dB/m)	Cable Loss (dB)	Preamp Factor (dB)	Antenna Height (cm)	Table Angle (Degree)	Remark
2389.06	35.65	41.81	54	-18.35	27.01	4.33	37.5	139	58	Average
2389.06	47.52	53.68	74	-26.48	27.01	4.33	37.5	139	58	Peak
2402	87.26	93.25			27.16	4.37	37.52	139	58	Average
2402	88.05	94.04			27.16	4.37	37.52	139	58	Peak
4804	33.9	49.59	54	-20.1	31.14	6.07	52.9	118	200	Average
4804	44.1	59.79	74	-29.9	31.14	6.07	52.9	118	200	Peak

Remarks:

1. Emission Level = Read Level + Antenna Factor + Cable Loss - Preamp Factor  
Margin value = Emission level – Limit value
2. 2402 MHz: Fundamental frequency.
3. The other emission levels were very low against the limit.



EUT Test Condition		Measurement Detail	
Channel	Channel 19	Frequency Range	1 GHz ~ 25 GHz
Input Power	120 Vac, 60 Hz	Detector Function	Peak (PK) Average (AV)
Environmental Conditions	25 deg. C, 65 % RH	Tested By	Thomas Wei

### Horizontal

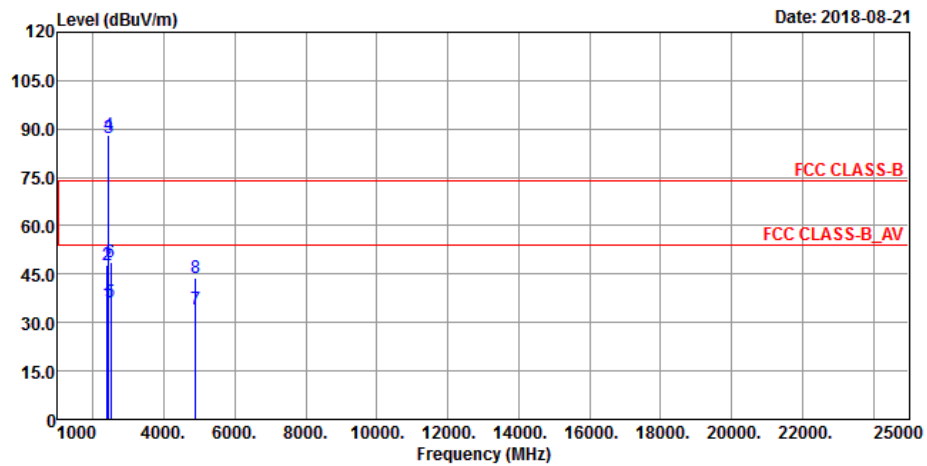

### Vertical

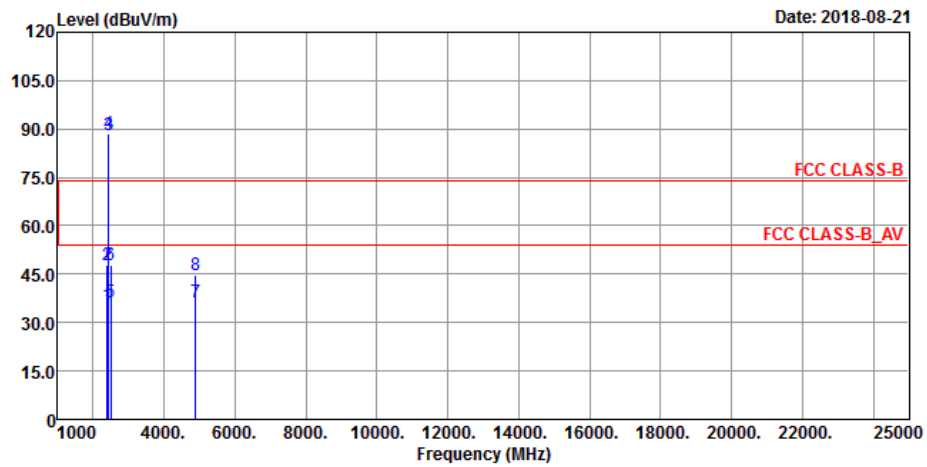

**Antenna Polarity & Test Distance: Horizontal at 3 m**

Frequency (MHz)	Emission Level (dBuV/m)	Read Level (dBuV)	Limit (dBuV/m)	Margin (dB)	Antenna Factor (dB/m)	Cable Loss (dB)	Preamp Factor (dB)	Antenna Height (cm)	Table Angle (Degree)	Remark
2386.55	35.98	42.05	54	-18.02	27.08	4.35	37.5	164	357	Average
2386.55	47.91	53.98	74	-26.09	27.08	4.35	37.5	164	357	Peak
2440	87.45	93.13			27.38	4.4	37.46	164	357	Average
2440	88.14	93.82			27.38	4.4	37.46	164	357	Peak
2490	36.49	41.69	54	-17.51	27.61	4.44	37.25	164	357	Average
2490	48.92	54.12	74	-25.08	27.61	4.44	37.25	164	357	Peak
4880	33.89	48.64	54	-20.11	31.25	6.86	52.86	143	207	Average
4880	43.94	58.69	74	-30.06	31.25	6.86	52.86	143	207	Peak

**Antenna Polarity & Test Distance: Vertical at 3 m**

Frequency (MHz)	Emission Level (dBuV/m)	Read Level (dBuV)	Limit (dBuV/m)	Margin (dB)	Antenna Factor (dB/m)	Cable Loss (dB)	Preamp Factor (dB)	Antenna Height (cm)	Table Angle (Degree)	Remark
2389.44	35.25	41.33	54	-18.75	27.08	4.34	37.5	146	355	Average
2389.44	47.77	53.85	74	-26.23	27.08	4.34	37.5	146	355	Peak
2440	87.99	93.67			27.38	4.4	37.46	146	355	Average
2440	88.75	94.43			27.38	4.4	37.46	146	355	Peak
2485.12	36.19	41.39	54	-17.81	27.61	4.44	37.25	146	355	Average
2485.12	47.98	53.18	74	-26.02	27.61	4.44	37.25	146	355	Peak
4880	36.2	50.95	54	-17.8	31.25	6.86	52.86	144	163	Average
4880	44.87	59.62	74	-29.13	31.25	6.86	52.86	144	163	Peak

Remarks:

- Emission Level = Read Level + Antenna Factor + Cable Loss - Preamp Factor  
Margin value = Emission level – Limit value
- 2440 MHz: Fundamental frequency.
- The other emission levels were very low against the limit.

EUT Test Condition		Measurement Detail	
Channel	Channel 39	Frequency Range	1 GHz ~ 25 GHz
Input Power	120 Vac, 60 Hz	Detector Function	Peak (PK) Average (AV)
Environmental Conditions	25 deg. C, 65 % RH	Tested By	Thomas Wei

### Horizontal

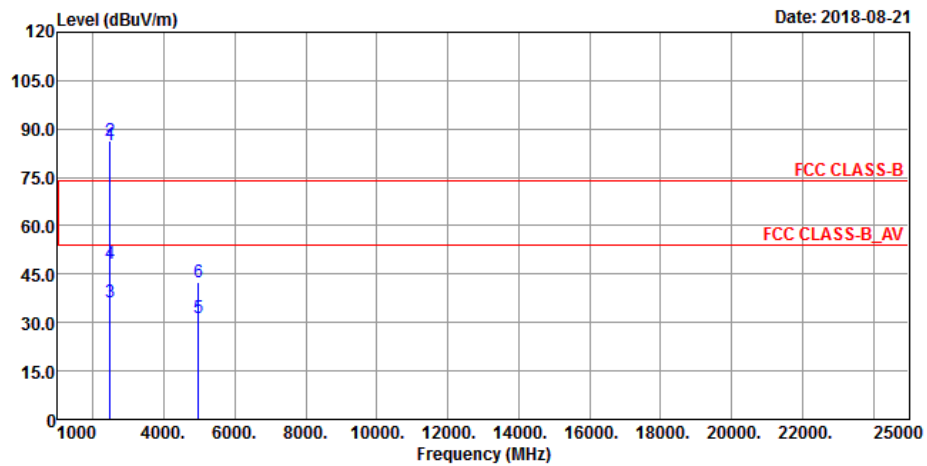

### Vertical

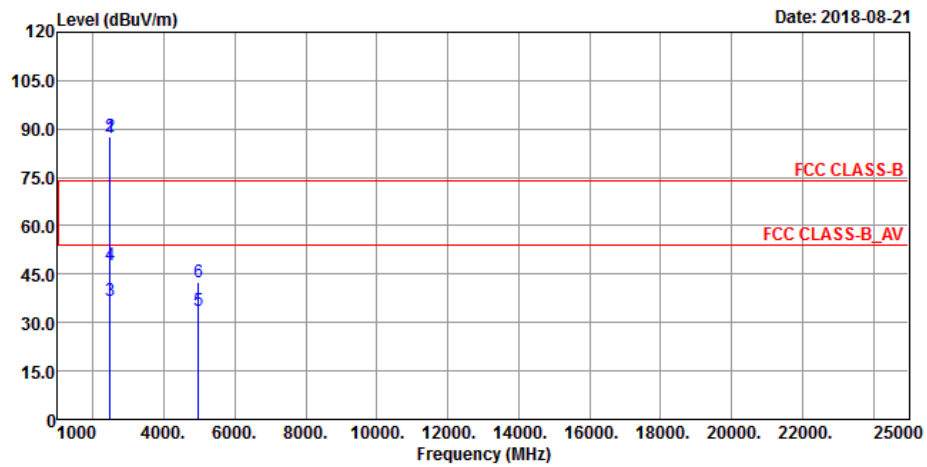

Antenna Polarity & Test Distance: Horizontal at 3 m										
Frequency (MHz)	Emission Level (dBuV/m)	Read Level (dBuV)	Limit (dBuV/m)	Margin (dB)	Antenna Factor (dB/m)	Cable Loss (dB)	Preamp Factor (dB)	Antenna Height (cm)	Table Angle (Degree)	Remark
2480	84.95	90.31			27.53	4.43	37.32	157	51	Average
2480	86.48	91.84			27.53	4.43	37.32	157	51	Peak
2483.5	36.41	41.61	54	-17.59	27.61	4.44	37.25	157	51	Average
2483.5	48.42	53.62	74	-25.58	27.61	4.44	37.25	157	51	Peak
4960	31.64	46.96	54	-22.36	31.4	6.2	52.92	155	179	Average
4960	42.48	57.8	74	-31.52	31.4	6.2	52.92	155	179	Peak
Antenna Polarity & Test Distance: Vertical at 3 m										
Frequency (MHz)	Emission Level (dBuV/m)	Read Level (dBuV)	Limit (dBuV/m)	Margin (dB)	Antenna Factor (dB/m)	Cable Loss (dB)	Preamp Factor (dB)	Antenna Height (cm)	Table Angle (Degree)	Remark
2480	87.1	92.46			27.53	4.43	37.32	172	336	Average
2480	87.85	93.21			27.53	4.43	37.32	172	336	Peak
2483.89	36.59	41.87	54	-17.41	27.61	4.43	37.32	172	336	Average
2483.89	48.03	53.31	74	-25.97	27.61	4.43	37.32	172	336	Peak
4960	33.44	48.76	54	-20.56	31.4	6.2	52.92	114	325	Average
4960	42.29	57.61	74	-31.71	31.4	6.2	52.92	114	325	Peak

Remarks:

1. Emission Level = Read Level + Antenna Factor + Cable Loss - Preamp Factor  
Margin value = Emission level – Limit value
2. 2480 MHz: Fundamental frequency.
3. The other emission levels were very low against the limit.

**Mode B**

EUT Test Condition		Measurement Detail	
Channel	Channel 0	Frequency Range	1 GHz ~ 25 GHz
Input Power	120 Vac, 60 Hz	Detector Function	Peak (PK) Average (AV)
Environmental Conditions	25 deg. C, 65 % RH	Tested By	Thomas Wei

**Horizontal**

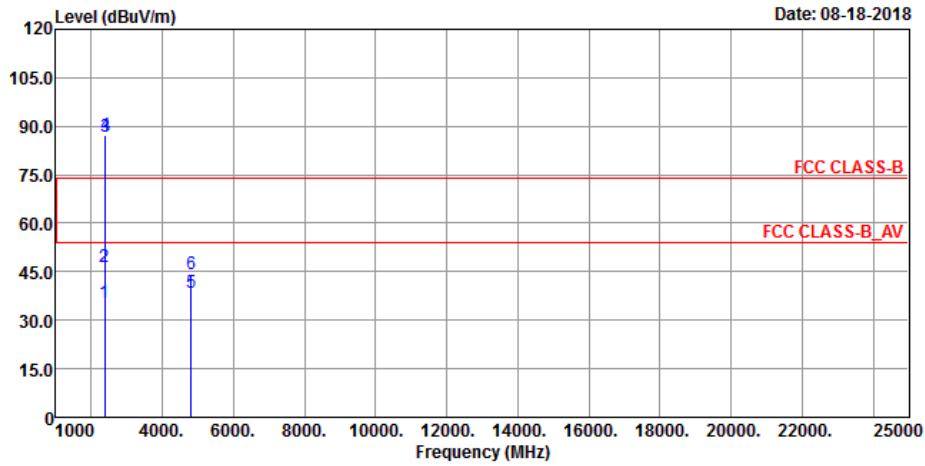

**Vertical**

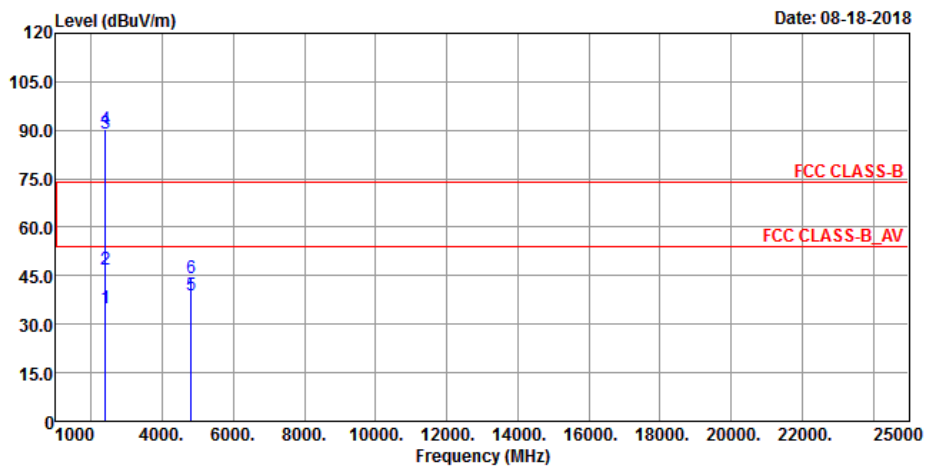

Antenna Polarity & Test Distance: Horizontal at 3 m										
Frequency (MHz)	Emission Level (dBuV/m)	Read Level (dBuV)	Limit (dBuV/m)	Margin (dB)	Antenna Factor (dB/m)	Cable Loss (dB)	Preamp Factor (dB)	Antenna Height (cm)	Table Angle (Degree)	Remark
2376.49	35.5	41.48	54	-18.5	27.16	4.36	37.5	172	258	Average
2376.49	46.37	52.35	74	-27.63	27.16	4.36	37.5	172	258	Peak
2402	86.65	92.64			27.16	4.37	37.52	172	258	Average
2402	87.31	93.3			27.16	4.37	37.52	172	258	Peak
4804	38.35	54.04	54	-15.65	31.14	6.07	52.9	152	169	Average
4804	44.35	60.04	74	-29.65	31.14	6.07	52.9	152	169	Peak
Antenna Polarity & Test Distance: Vertical at 3 m										
Frequency (MHz)	Emission Level (dBuV/m)	Read Level (dBuV)	Limit (dBuV/m)	Margin (dB)	Antenna Factor (dB/m)	Cable Loss (dB)	Preamp Factor (dB)	Antenna Height (cm)	Table Angle (Degree)	Remark
2388.03	35.11	41.18	54	-18.89	27.08	4.35	37.5	181	210	Average
2388.03	47.14	53.21	74	-26.86	27.08	4.35	37.5	181	210	Peak
2402	89.18	95.17			27.16	4.37	37.52	181	210	Average
2402	90.28	96.27			27.16	4.37	37.52	181	210	Peak
4804	38.84	54.53	54	-15.16	31.14	6.07	52.9	168	71	Average
4804	44.08	59.77	74	-29.92	31.14	6.07	52.9	168	71	Peak

Remarks:

1. Emission Level = Read Level + Antenna Factor + Cable Loss - Preamp Factor  
Margin value = Emission level – Limit value
2. 2402 MHz: Fundamental frequency.
3. The other emission levels were very low against the limit.

EUT Test Condition		Measurement Detail	
Channel	Channel 19	Frequency Range	1 GHz ~ 25 GHz
Input Power	120 Vac, 60 Hz	Detector Function	Peak (PK) Average (AV)
Environmental Conditions	25 deg. C, 65 % RH	Tested By	Thomas Wei

### Horizontal

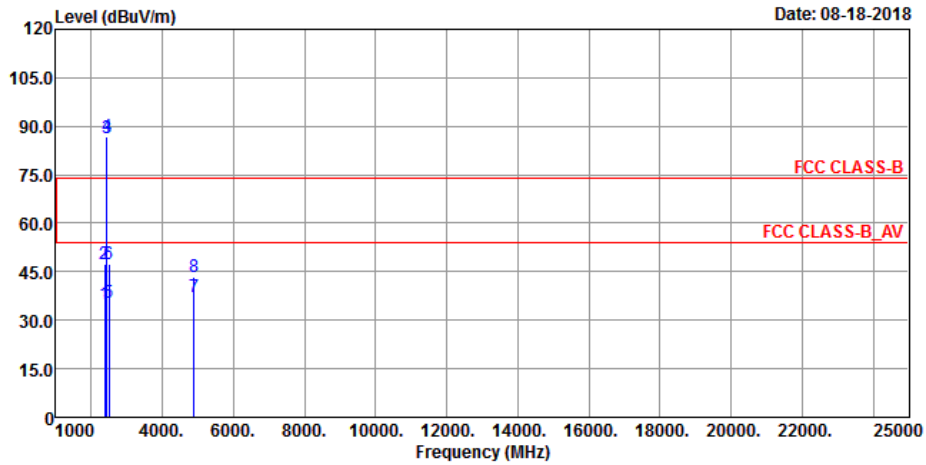

### Vertical

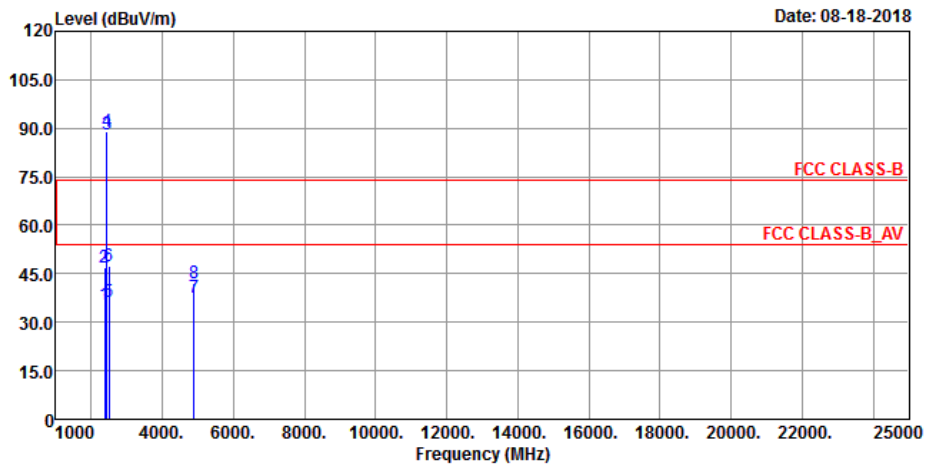

**Antenna Polarity & Test Distance: Horizontal at 3 m**

Frequency (MHz)	Emission Level (dBuV/m)	Read Level (dBuV)	Limit (dBuV/m)	Margin (dB)	Antenna Factor (dB/m)	Cable Loss (dB)	Preamp Factor (dB)	Antenna Height (cm)	Table Angle (Degree)	Remark
2376.55	35.14	41.21	54	-18.86	27.08	4.35	37.5	192	241	Average
2376.55	47.28	53.35	74	-26.72	27.08	4.35	37.5	192	241	Peak
2440	86.22	91.9			27.38	4.4	37.46	192	241	Average
2440	86.63	92.31			27.38	4.4	37.46	192	241	Peak
2486.38	35.42	40.7	54	-18.58	27.61	4.43	37.32	192	241	Average
2486.38	47.31	52.59	74	-26.69	27.61	4.43	37.32	192	241	Peak
4880	37.37	52.82	54	-16.63	31.25	6.16	52.86	155	147	Average
4880	43.27	58.73	74	-30.73	31.25	6.15	52.86	155	147	Peak

**Antenna Polarity & Test Distance: Vertical at 3 m**

Frequency (MHz)	Emission Level (dBuV/m)	Read Level (dBuV)	Limit (dBuV/m)	Margin (dB)	Antenna Factor (dB/m)	Cable Loss (dB)	Preamp Factor (dB)	Antenna Height (cm)	Table Angle (Degree)	Remark
2381	35.49	41.56	54	-18.51	27.08	4.35	37.5	167	175	Average
2381	46.88	52.95	74	-27.12	27.08	4.35	37.5	167	175	Peak
2440	88.24	93.92			27.38	4.4	37.46	167	175	Average
2440	89.07	94.75			27.38	4.4	37.46	167	175	Peak
2496.56	36.22	41.42	54	-17.78	27.61	4.44	37.25	167	175	Average
2496.56	47.39	52.59	74	-26.61	27.61	4.44	37.25	167	175	Peak
4880	37.42	52.87	54	-16.58	31.25	6.16	52.86	133	322	Average
4880	41.99	57.44	74	-32.01	31.25	6.16	52.86	133	322	Peak

Remarks:

- Emission Level = Read Level + Antenna Factor + Cable Loss - Preamp Factor  
Margin value = Emission level – Limit value
- 2440 MHz: Fundamental frequency.
- The other emission levels were very low against the limit.



EUT Test Condition		Measurement Detail	
Channel	Channel 39	Frequency Range	1 GHz ~ 25 GHz
Input Power	120 Vac, 60 Hz	Detector Function	Peak (PK) Average (AV)
Environmental Conditions	25 deg. C, 65 % RH	Tested By	Thomas Wei

**Horizontal**

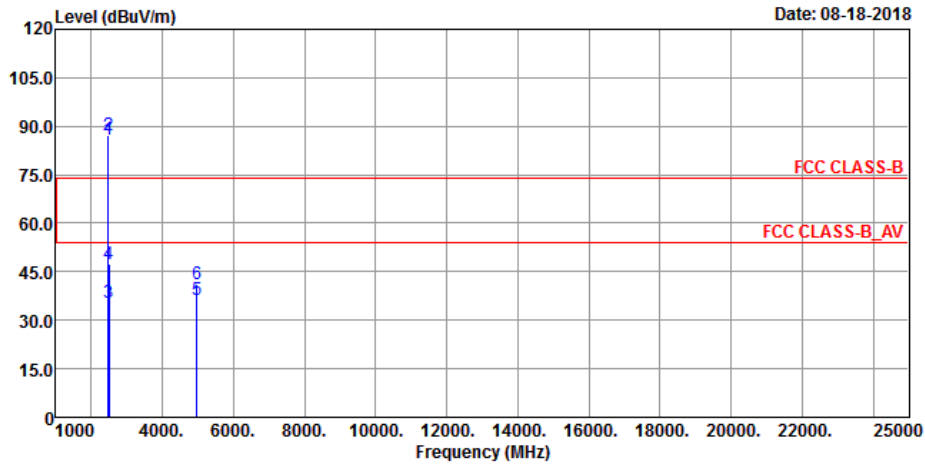

**Vertical**

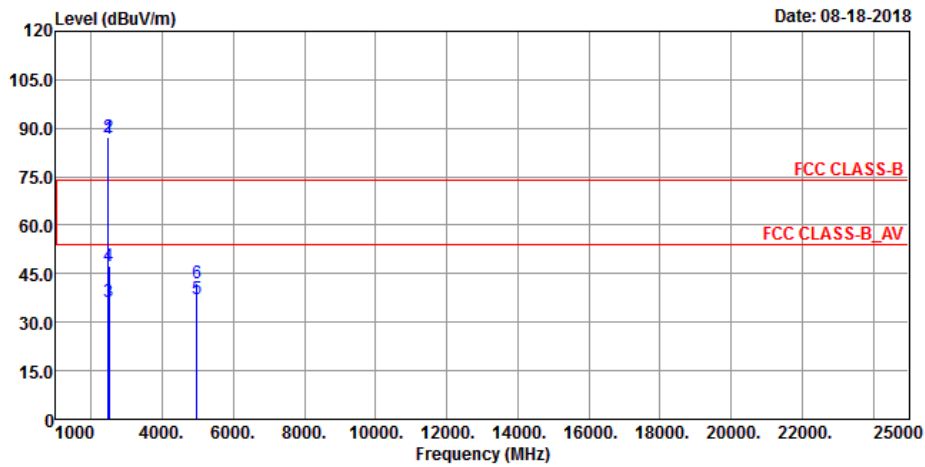

Antenna Polarity & Test Distance: Horizontal at 3 m										
Frequency (MHz)	Emission Level (dBuV/m)	Read Level (dBuV)	Limit (dBuV/m)	Margin (dB)	Antenna Factor (dB/m)	Cable Loss (dB)	Preamp Factor (dB)	Antenna Height (cm)	Table Angle (Degree)	Remark
2480	86.03	91.39			27.53	4.43	37.32	175	192	Average
2480	87.13	92.49			27.53	4.43	37.32	175	195	Peak
2488.69	35.27	40.48	54	-18.73	27.61	4.43	37.25	175	192	Average
2488.69	47.23	52.44	74	-26.77	27.61	4.43	37.25	175	192	Peak
4960	36.25	51.57	54	-17.75	31.4	6.2	52.92	104	324	Average
4960	41.32	56.64	74	-32.68	31.4	6.2	52.92	104	324	Peak
Antenna Polarity & Test Distance: Vertical at 3 m										
Frequency (MHz)	Emission Level (dBuV/m)	Read Level (dBuV)	Limit (dBuV/m)	Margin (dB)	Antenna Factor (dB/m)	Cable Loss (dB)	Preamp Factor (dB)	Antenna Height (cm)	Table Angle (Degree)	Remark
2480	86.78	92.14			27.53	4.43	37.32	143	306	Average
2480	87.45	92.81			27.53	4.43	37.32	143	306	Peak
2491.22	36.18	41.54	54	-17.82	27.53	4.43	37.32	143	306	Average
2491.22	47.55	52.91	74	-26.45	27.53	4.43	37.32	143	306	Peak
4960	37.29	52.61	54	-16.71	31.4	6.2	52.92	135	81	Average
4960	42.15	57.47	74	-31.85	31.4	6.2	52.92	135	81	Peak

Remarks:

1. Emission Level = Read Level + Antenna Factor + Cable Loss - Preamp Factor  
Margin value = Emission level – Limit value
2. 2480 MHz: Fundamental frequency.
3. The other emission levels were very low against the limit.

**9 kHz ~ 30 MHz Data:**

The amplitude of spurious emissions attenuated more than 20 dB below the permissible value is not required to be report.

**30 MHz ~ 1 GHz Worst-Case Data:**

**Mode A**

EUT Test Condition		Measurement Detail	
Channel	Channel 39	Frequency Range	30 MHz ~ 1 GHz
Input Power	120 Vac, 60 Hz	Detector Function	Peak (PK) Quasi-peak (QP)
Environmental Conditions	25 deg. C, 65 % RH	Tested By	Thomas Wei

**Horizontal**

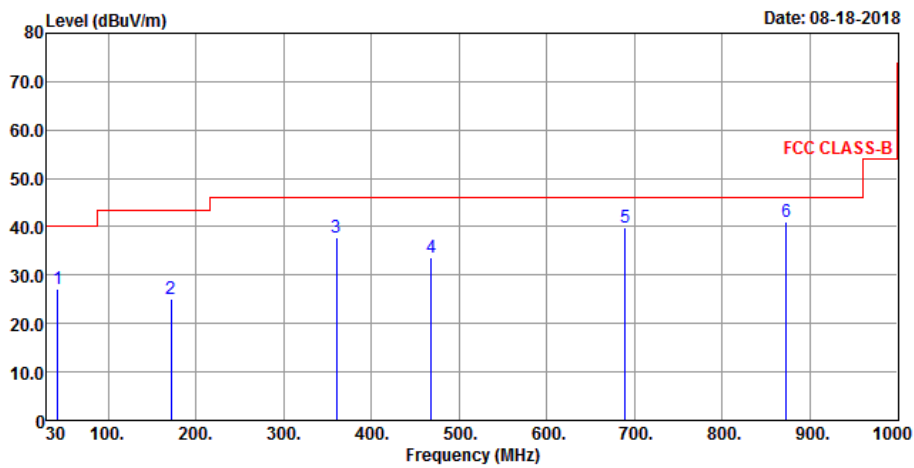

**Vertical**

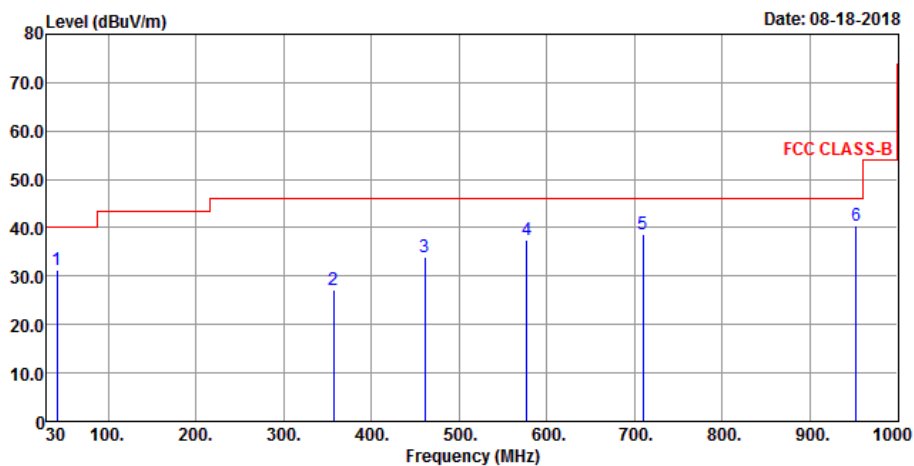

**Antenna Polarity & Test Distance: Horizontal at 3 m**

Frequency (MHz)	Emission Level (dBuV/m)	Read Level (dBuV)	Limit (dBuV/m)	Margin (dB)	Antenna Factor (dB/m)	Cable Loss (dB)	Preamp Factor (dB)	Antenna Height (cm)	Table Angle (Degree)	Remark
42.61	27.09	44.09	40	-12.91	13.58	0.5	31.08	168	222	Peak
171.62	24.99	44.09	43.5	-18.51	11.57	1.08	31.75	194	225	Peak
359.8	37.73	53.4	46	-8.27	14.38	1.92	31.97	147	58	Peak
468.44	33.59	46.44	46	-12.41	16.7	2.36	31.91	227	179	Peak
689.6	39.96	47.85	46	-6.04	20.69	3.26	31.84	312	208	Peak
<b>872.93</b>	<b>41.01</b>	<b>45.91</b>	<b>46</b>	<b>-4.99</b>	<b>23.16</b>	<b>3.94</b>	<b>32</b>	<b>197</b>	<b>223</b>	<b>Peak</b>

**Antenna Polarity & Test Distance: Vertical at 3 m**

Frequency (MHz)	Emission Level (dBuV/m)	Read Level (dBuV)	Limit (dBuV/m)	Margin (dB)	Antenna Factor (dB/m)	Cable Loss (dB)	Preamp Factor (dB)	Antenna Height (cm)	Table Angle (Degree)	Remark
41.64	31.38	48.37	40	-8.62	13.56	0.5	31.05	301	159	Peak
356.89	27.25	42.96	46	-18.75	14.31	1.91	31.93	267	68	Peak
460.68	33.94	47.06	46	-12.06	16.54	2.32	31.98	249	115	Peak
577.08	37.56	47.79	46	-8.44	19.08	2.8	32.11	227	189	Peak
709.97	38.8	46.23	46	-7.2	20.96	3.35	31.74	181	233	Peak
952.47	40.54	44.35	46	-5.46	23.8	4.24	31.85	158	311	Peak

## Remarks:

- Emission Level = Read Level + Antenna Factor + Cable Loss - Preamp Factor  
Margin value = Emission level – Limit value
- The other emission levels were very low against the limit.

### Mode B

EUT Test Condition		Measurement Detail	
Channel	Channel 0	Frequency Range	30 MHz ~ 1 GHz
Input Power	120 Vac, 60 Hz	Detector Function	Peak (PK) Quasi-peak (QP)
Environmental Conditions	25 deg. C, 65 % RH	Tested By	Thomas Wei

### Horizontal

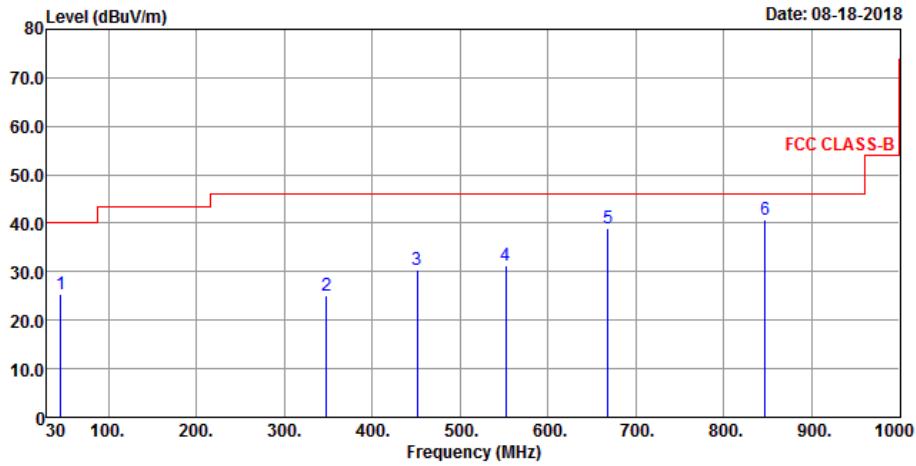

### Vertical

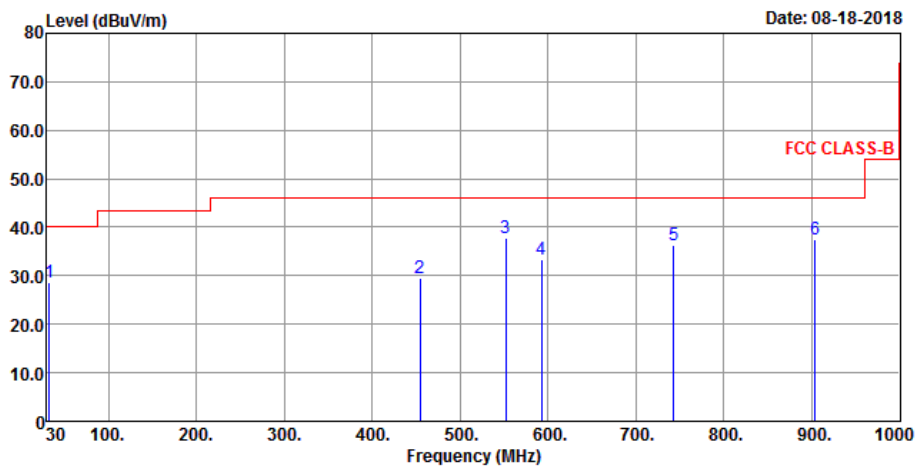

Antenna Polarity & Test Distance: Horizontal at 3 m										
Frequency (MHz)	Emission Level (dBuV/m)	Read Level (dBuV)	Limit (dBuV/m)	Margin (dB)	Antenna Factor (dB/m)	Cable Loss (dB)	Preamp Factor (dB)	Antenna Height (cm)	Table Angle (Degree)	Remark
45.52	25.35	42.5	40	-14.65	13.5	0.51	31.16	319	233	Peak
348.16	25.03	40.9	46	-20.97	14.1	1.87	31.84	255	322	Peak
450.98	30.32	43.66	46	-15.68	16.35	2.29	31.98	238	158	Peak
551.86	31.31	42.08	46	-14.69	18.5	2.7	31.97	206	199	Peak
668.26	38.92	47.16	46	-7.08	20.43	3.17	31.84	155	31	Peak
846.74	40.81	46	46	-5.19	22.83	3.83	31.85	122	147	Peak
Antenna Polarity & Test Distance: Vertical at 3 m										
Frequency (MHz)	Emission Level (dBuV/m)	Read Level (dBuV)	Limit (dBuV/m)	Margin (dB)	Antenna Factor (dB/m)	Cable Loss (dB)	Preamp Factor (dB)	Antenna Height (cm)	Table Angle (Degree)	Remark
32.91	28.65	46.81	40	-11.35	12.47	0.46	31.09	136	258	Peak
454.86	29.38	42.64	46	-16.62	16.43	2.3	31.99	189	233	Peak
552.37	37.8	48.57	46	-8.2	18.5	2.7	31.97	235	46	Peak
592.6	33.32	43.19	46	-12.68	19.43	2.87	32.17	287	315	Peak
742.95	36.33	42.86	46	-9.67	21.42	3.48	31.43	227	196	Peak
903.97	37.35	41.8	46	-8.65	23.53	4.05	32.03	203	247	Peak

Remarks:

1. Emission Level = Read Level + Antenna Factor + Cable Loss - Preamp Factor  
Margin value = Emission level – Limit value
2. The other emission levels were very low against the limit.

## 4.11 Conducted Emission Measurement

### 4.11.1 Limits of Conducted Emission Measurement

Frequency (MHz)	Conducted Limit (dBuV)	
	Quasi-Peak	Average
0.15 - 0.5	66 - 56	56 - 46
0.50 - 5.0	56	46
5.0 - 30.0	60	50

Note: 1. The lower limit shall apply at the transition frequencies.  
 2. The limit decreases in line with the logarithm of the frequency in the range of 0.15 to 0.50 MHz.

### 4.11.2 Test Instruments

Refer to section 4.2.2 to get information of the instrument.

### 4.11.3 Test Procedures

- a. The EUT was placed 0.4 meters from the conducting wall of the shielded room with EUT being connected to the power mains through a line impedance stabilization network (LISN). Other support units were connected to the power mains through another LISN. The two LISNs provide 50 ohm/50 uH of coupling impedance for the measuring instrument.
- b. Both lines of the power mains connected to the EUT were checked for maximum conducted interference.
- c. The frequency range from 150 kHz to 30 MHz was searched. Emission levels under (Limit – 20 dB) was not recorded.

**Note:** The resolution bandwidth and video bandwidth of test receiver is 9 kHz for quasi-peak detection (QP) and average detection (AV) at frequency 0.15 MHz - 30 MHz.

#### 4.11.4 Deviation from Test Standard

No deviation.

#### 4.11.5 Test Setup

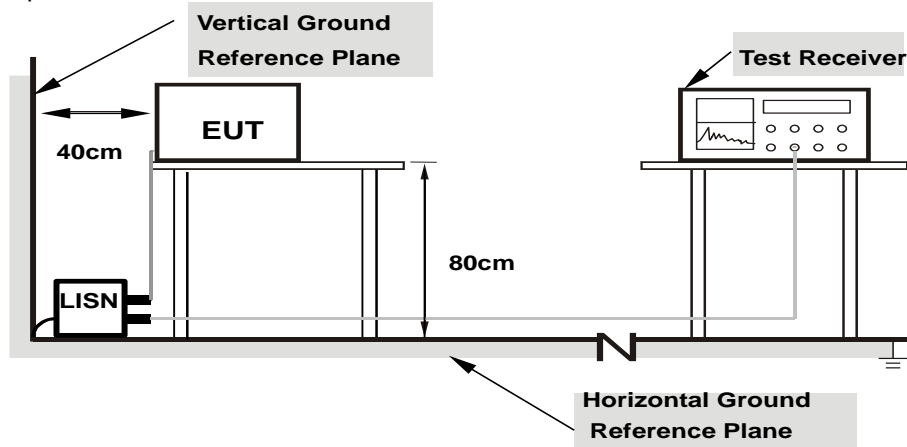

- Note: 1.Support units were connected to second LISN.**  
**2.Both of LISNs (AMN) are 80 cm from EUT and at least 80 from other units and other metal planes**

#### 4.11.6 EUT Operating Conditions

- Placed the EUT on the testing table.
- Set the EUT under transmission condition continuously at specific channel frequency.



#### 4.11.7 Test Results

### CONDUCTED WORST-CASE DATA

#### Mode A

Frequency Range	150kHz ~ 30MHz	Detector Function & Resolution Bandwidth	Quasi-Peak (QP) / Average (AV), 9kHz
Input Power	120Vac, 60Hz	Environmental Conditions	25°C, 65%RH
Tested by	Jisyong Wang	Test Date	2018/7/21

Phase Of Power : Line (L)										
No	Frequency (MHz)	Correction Factor (dB)	Reading Value (dBuV)		Emission Level (dBuV)		Limit (dBuV)		Margin (dB)	
			Q.P.	AV.	Q.P.	AV.	Q.P.	AV.	Q.P.	AV.
1	0.19305	9.67	27.00	12.66	36.67	22.33	63.90	53.90	-27.23	-31.57
2	0.22038	9.67	27.53	8.69	37.20	18.36	62.80	52.80	-25.60	-34.44
3	0.33377	9.67	26.05	5.10	35.72	14.77	59.36	49.36	-23.64	-34.59
4	0.61138	9.67	23.99	10.02	33.66	19.69	56.00	46.00	-22.34	-26.31
5	10.15960	9.87	20.11	5.29	29.98	15.16	60.00	50.00	-30.02	-34.84
6	18.52309	9.94	20.12	6.27	30.06	16.21	60.00	50.00	-29.94	-33.79

#### Remarks:

1. Q.P. and AV. are abbreviations of quasi-peak and average individually.
2. The emission levels of other frequencies were very low against the limit.
3. Margin value = Emission level – Limit value
4. Correction factor = Insertion loss + Cable loss
5. Emission Level = Correction Factor + Reading Value

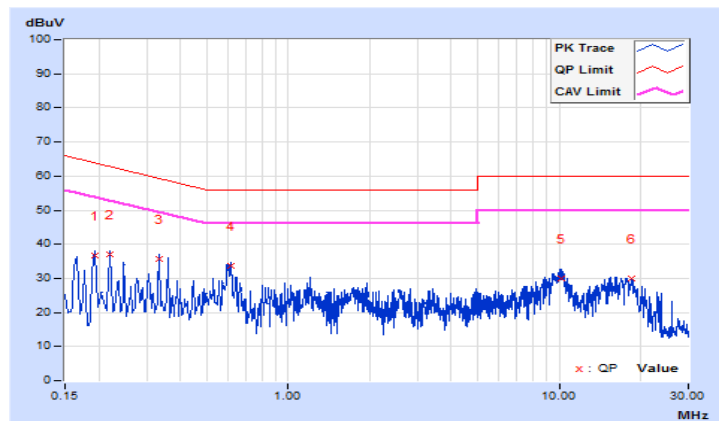

Frequency Range	150kHz ~ 30MHz	Detector Function & Resolution Bandwidth	Quasi-Peak (QP) / Average (AV), 9kHz
Input Power	120Vac, 60Hz	Environmental Conditions	25°C, 65%RH
Tested by	Jisyong Wang	Test Date	2018/7/21

Phase Of Power : Neutral (N)										
No	Frequency (MHz)	Correction Factor (dB)	Reading Value (dBuV)		Emission Level (dBuV)		Limit (dBuV)		Margin (dB)	
			Q.P.	AV.	Q.P.	AV.	Q.P.	AV.	Q.P.	AV.
1	0.15760	9.68	26.54	8.32	36.22	18.00	65.59	55.59	-29.37	-37.59
2	0.18508	9.68	23.41	7.29	33.09	16.97	64.25	54.25	-31.16	-37.28
3	0.60747	9.68	22.90	9.36	32.58	19.04	56.00	46.00	-23.42	-26.96
4	1.98793	9.71	19.45	4.29	29.16	14.00	56.00	46.00	-26.84	-32.00
5	9.13909	9.86	24.13	8.88	33.99	18.74	60.00	50.00	-26.01	-31.26
6	15.82519	9.98	21.31	3.56	31.29	13.54	60.00	50.00	-28.71	-36.46

Remarks:

1. Q.P. and AV. are abbreviations of quasi-peak and average individually.
2. The emission levels of other frequencies were very low against the limit.
3. Margin value = Emission level – Limit value
4. Correction factor = Insertion loss + Cable loss
5. Emission Level = Correction Factor + Reading Value

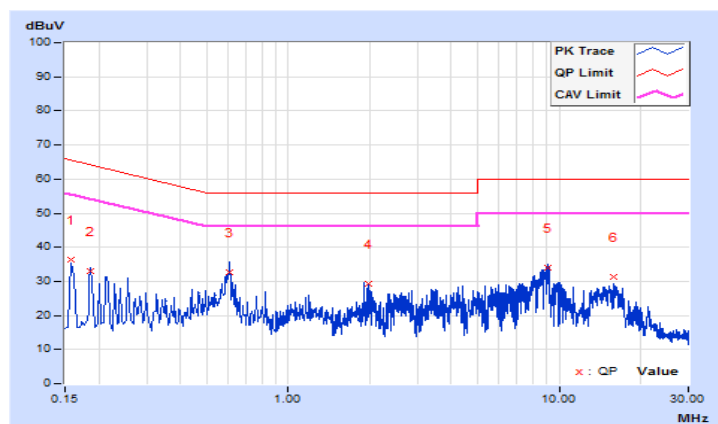

**Mode B**

Frequency Range	150kHz ~ 30MHz	Detector Function & Resolution Bandwidth	Quasi-Peak (QP) / Average (AV), 9kHz
Input Power	120Vac, 60Hz	Environmental Conditions	25°C, 65%RH
Tested by	Jisyong Wang	Test Date	2018/7/21

Phase Of Power : Line (L)										
No	Frequency (MHz)	Correction Factor (dB)	Reading Value (dBuV)		Emission Level (dBuV)		Limit (dBuV)		Margin (dB)	
			Q.P.	AV.	Q.P.	AV.	Q.P.	AV.	Q.P.	AV.
1	0.15782	9.67	28.47	10.74	38.14	20.41	65.58	55.58	-27.44	-35.17
2	0.24384	9.67	23.00	8.59	32.67	18.26	61.96	51.96	-29.29	-33.70
3	0.32595	9.67	21.36	3.93	31.03	13.60	59.55	49.55	-28.52	-35.95
4	0.59158	9.67	21.90	8.50	31.57	18.17	56.00	46.00	-24.43	-27.83
5	10.46458	9.88	19.06	5.34	28.94	15.22	60.00	50.00	-31.06	-34.78
6	20.50155	9.95	21.20	5.90	31.15	15.85	60.00	50.00	-28.85	-34.15

Remarks:

1. Q.P. and AV. are abbreviations of quasi-peak and average individually.
2. The emission levels of other frequencies were very low against the limit.
3. Margin value = Emission level – Limit value
4. Correction factor = Insertion loss + Cable loss
5. Emission Level = Correction Factor + Reading Value

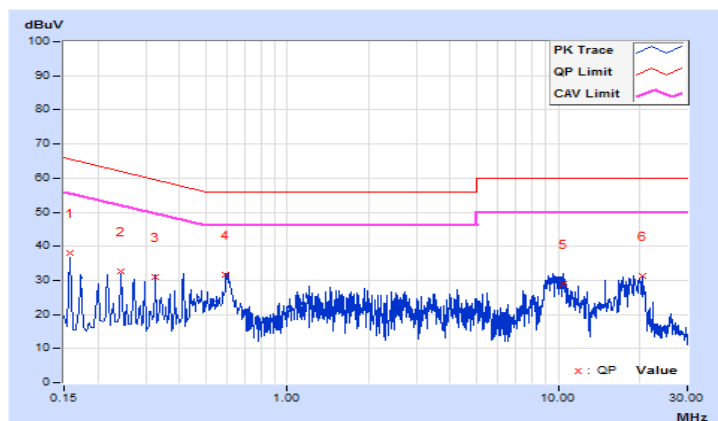

Frequency Range	150kHz ~ 30MHz	Detector Function & Resolution Bandwidth	Quasi-Peak (QP) / Average (AV), 9kHz
Input Power	120Vac, 60Hz	Environmental Conditions	25°C, 65%RH
Tested by	Jisyong Wang	Test Date	2018/7/21

Phase Of Power : Neutral (N)										
No	Frequency (MHz)	Correction Factor (dB)	Reading Value (dBuV)		Emission Level (dBuV)		Limit (dBuV)		Margin (dB)	
			Q.P.	AV.	Q.P.	AV.	Q.P.	AV.	Q.P.	AV.
1	0.18128	9.68	28.42	8.48	38.10	18.16	64.43	54.43	-26.33	-36.27
2	0.26730	9.68	28.47	9.24	38.15	18.92	61.20	51.20	-23.05	-32.28
<b>3</b>	<b>0.60356</b>	<b>9.68</b>	<b>26.53</b>	<b>11.94</b>	<b>36.21</b>	<b>21.62</b>	<b>56.00</b>	<b>46.00</b>	<b>-19.79</b>	<b>-24.38</b>
4	4.00135	9.75	23.77	6.85	33.52	16.60	56.00	46.00	-22.48	-29.40
5	10.19088	9.89	24.59	8.67	34.48	18.56	60.00	50.00	-25.52	-31.44
6	18.37060	10.02	19.60	5.93	29.62	15.95	60.00	50.00	-30.38	-34.05

Remarks:

1. Q.P. and AV. are abbreviations of quasi-peak and average individually.
2. The emission levels of other frequencies were very low against the limit.
3. Margin value = Emission level – Limit value
4. Correction factor = Insertion loss + Cable loss
5. Emission Level = Correction Factor + Reading Value

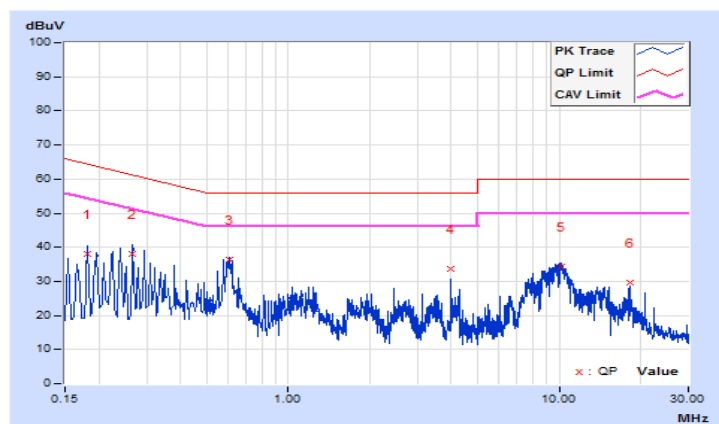

## 4.12 6 dB Bandwidth Measurement

### 4.12.1 Limits of 6 dB Bandwidth Measurement

The minimum of 6 dB Bandwidth Measurement is 0.5 MHz.

### 4.12.2 Test Setup

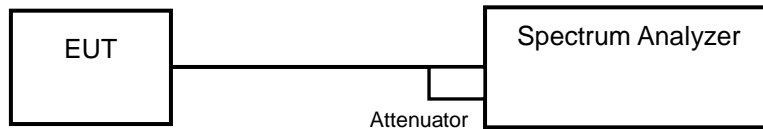

### 4.12.3 Test Instruments

Refer to section 4.1.2 to get information of above instrument.

### 4.12.4 Test Procedure

- Set resolution bandwidth (RBW) = 100 kHz
- Set the video bandwidth (VBW)  $\geq 3 \times$  RBW, Detector = Peak.
- Trace mode = max hold.
- Sweep = auto couple.
- Measure the maximum width of the emission that is constrained by the frequencies associated with the two amplitude points (upper and lower) that are attenuated by 6 dB relative to the maximum level measured in the fundamental emission

### 4.12.5 Deviation from Test Standard

No deviation.

### 4.12.6 EUT Operating Conditions

The software provided by client to enable the EUT under transmission condition continuously at lowest, middle and highest channel frequencies individually.

#### 4.12.7 Test Results

Channel	Frequency (MHz)	6 dB Bandwidth (MHz)	Minimum Limit (MHz)	Pass / Fail
0	2402	0.68	0.5	Pass
19	2440	0.68	0.5	Pass
39	2480	0.67	0.5	Pass

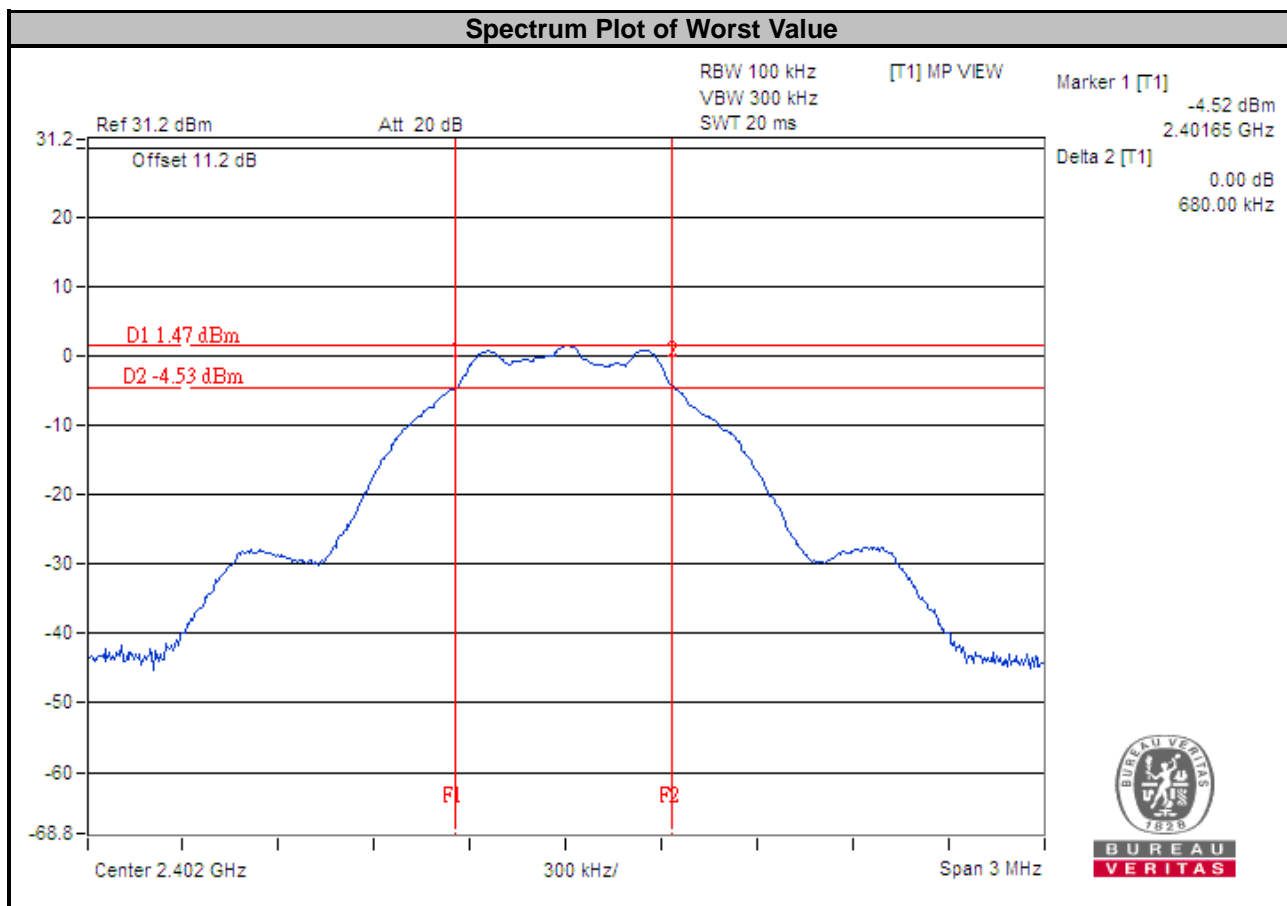

## 4.13 Occupied Bandwidth Measurement

### 4.13.1 Test Setup

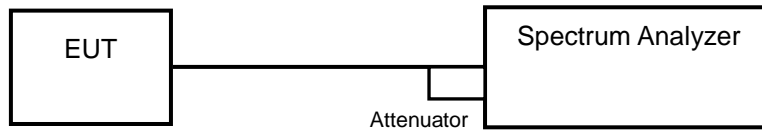

### 4.13.2 Test Instruments

Refer to section 4.1.2 to get information of above instrument.

### 4.13.3 Test Procedure

The transmitter output was connected to the spectrum analyzer through an attenuator. The bandwidth of the fundamental frequency was measured by spectrum analyzer with resolution bandwidth in the range of 1 % to 5 % of the anticipated emission bandwidth, and a video bandwidth at least 3x the resolution bandwidth and set the detector to PEAK. The width of a frequency band such that, below the lower and above the upper frequency limits, the mean powers emitted are each equal to a specified percentage 0.5 % of the total mean power of a given emission.

### 4.13.4 Deviation from Test Standard

No deviation.

### 4.13.5 EUT Operating Conditions

The software provided by client to enable the EUT under transmission condition continuously at lowest, middle and highest channel frequencies individually.





#### 4.14 Conducted Output Power Measurement

##### 4.14.1 Limits of Conducted Output Power Measurement

For systems using digital modulation in the 2400–2483.5 MHz bands: 1 Watt (30 dBm)

##### 4.14.2 Test Setup

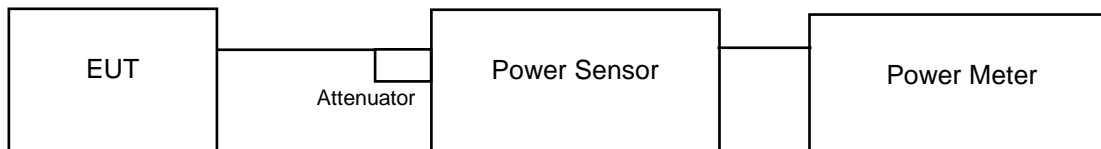

##### 4.14.3 Test Instruments

Refer to section 4.1.2 to get information of above instrument.

##### 4.14.4 Test Procedures

A peak power sensor was used on the output port of the EUT. A power meter was used to read the response of the peak power sensor. Record the power level.

##### 4.14.5 Deviation from Test Standard

No deviation.

##### 4.14.6 EUT Operating Conditions

The software provided by client to enable the EUT under transmission condition continuously at lowest, middle and highest channel frequencies individually.

##### 4.14.7 Test Results

Channel	Frequency (MHz)	Peak Power (mW)	Peak Power (dBm)	Limit (dBm)	Pass / Fail
0	2402	1.578	1.98	30	Pass
19	2440	1.445	1.60	30	Pass
39	2480	1.361	1.34	30	Pass

## 4.15 Power Spectral Density Measurement

### 4.15.1 Limits of Power Spectral Density Measurement

The Maximum of Power Spectral Density Measurement is 8 dBm.

### 4.15.2 Test Setup



### 4.15.3 Test Instruments

Refer to section 4.1.2 to get information of above instrument.

### 4.15.4 Test Procedure

- Set analyzer center frequency to DTS channel center frequency.
- Set the span to 1.5 times the DTS bandwidth.
- Set the RBW to:  $3 \text{ kHz} \leq \text{RBW} \leq 100 \text{ kHz}$ .
- Set the VBW  $\geq 3 \times \text{RBW}$ .
- Detector = peak.
- Sweep time = auto couple.
- Trace mode = max hold.
- Allow trace to fully stabilize.
- Use the peak marker function to determine the maximum amplitude level within the RBW.

### 4.15.5 Deviation from Test Standard

No deviation.

### 4.15.6 EUT Operating Condition

The software provided by client to enable the EUT under transmission condition continuously at lowest, middle and highest channel frequencies individually.

#### 4.15.7 Test Results

Channel	Frequency (MHz)	PSD (dBm/3 kHz)	Limit (dBm/3 kHz)	Pass / Fail
0	2402	-13.67	8	Pass
19	2440	-13.93	8	Pass
39	2480	-14.34	8	Pass

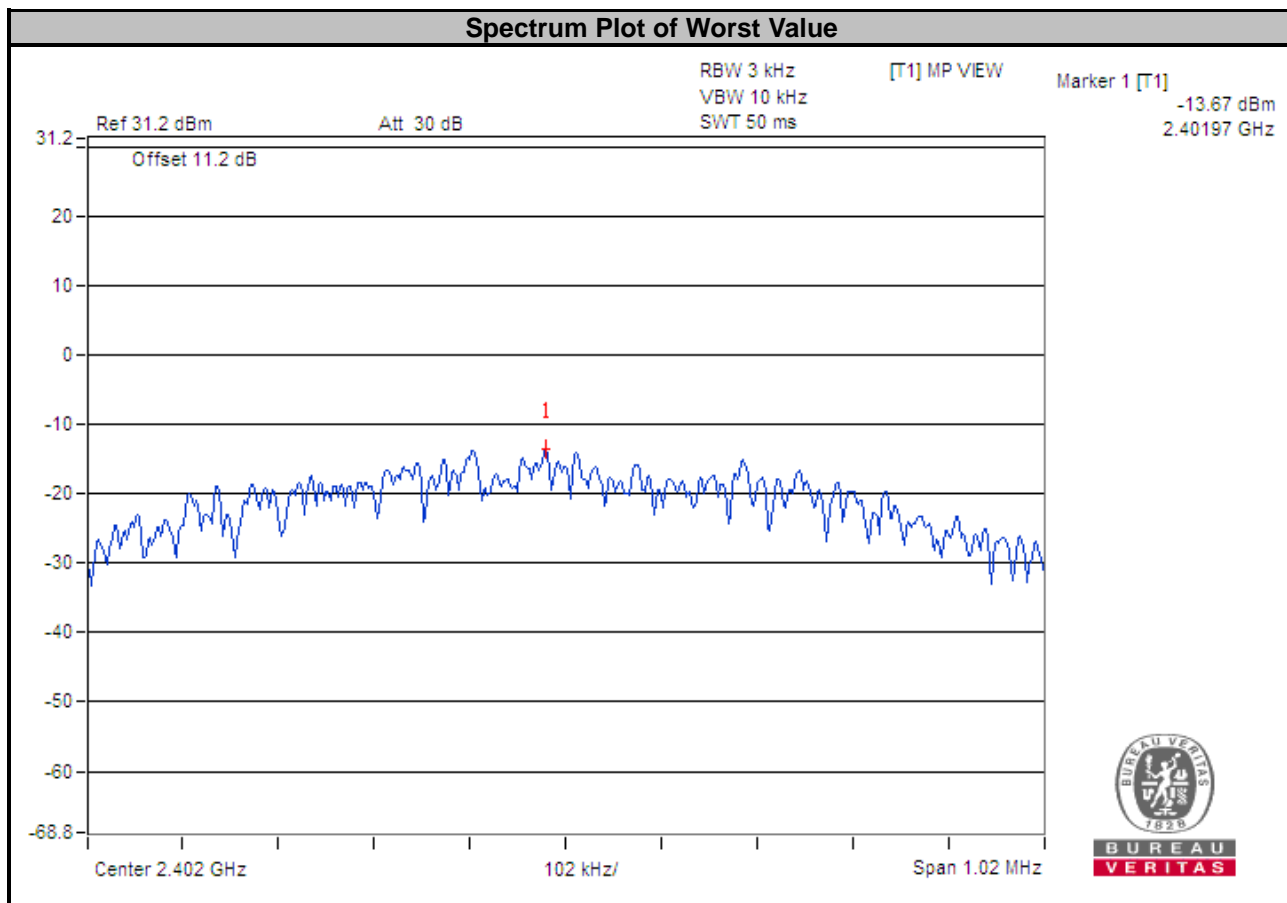

## 4.16 Conducted Out of Band Emission Measurement

### 4.16.1 Limits of Conducted Out of Band Emission Measurement

Below  $-20$  dB of the highest emission level of operating band (in 100 kHz Resolution Bandwidth).

### 4.16.2 Test Setup

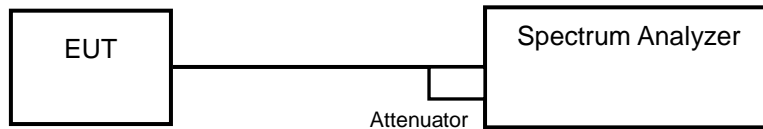

### 4.16.3 Test Instruments

Refer to section 4.1.2 to get information of above instrument.

### 4.16.4 Test Procedure

#### MEASUREMENT PROCEDURE REF

1. Set the RBW = 100 kHz.
2. Set the VBW  $\geq$  300 kHz.
3. Detector = peak.
4. Sweep time = auto couple.
5. Trace mode = max hold.
6. Allow trace to fully stabilize.
7. Use the peak marker function to determine the maximum power level in any 100 kHz band segment within the fundamental EBW.

#### MEASUREMENT PROCEDURE OOBE

1. Set RBW = 100 kHz.
2. Set VBW  $\geq$  300 kHz.
3. Detector = peak.
4. Sweep = auto couple.
5. Trace Mode = max hold.
6. Allow trace to fully stabilize.
7. Use the peak marker function to determine the maximum amplitude level.

### 4.16.5 Deviation from Test Standard

No deviation.

### 4.16.6 EUT Operating Condition

The software provided by client to enable the EUT under transmission condition continuously at lowest, middle and highest channel frequencies individually.

### 4.16.7 Test Results

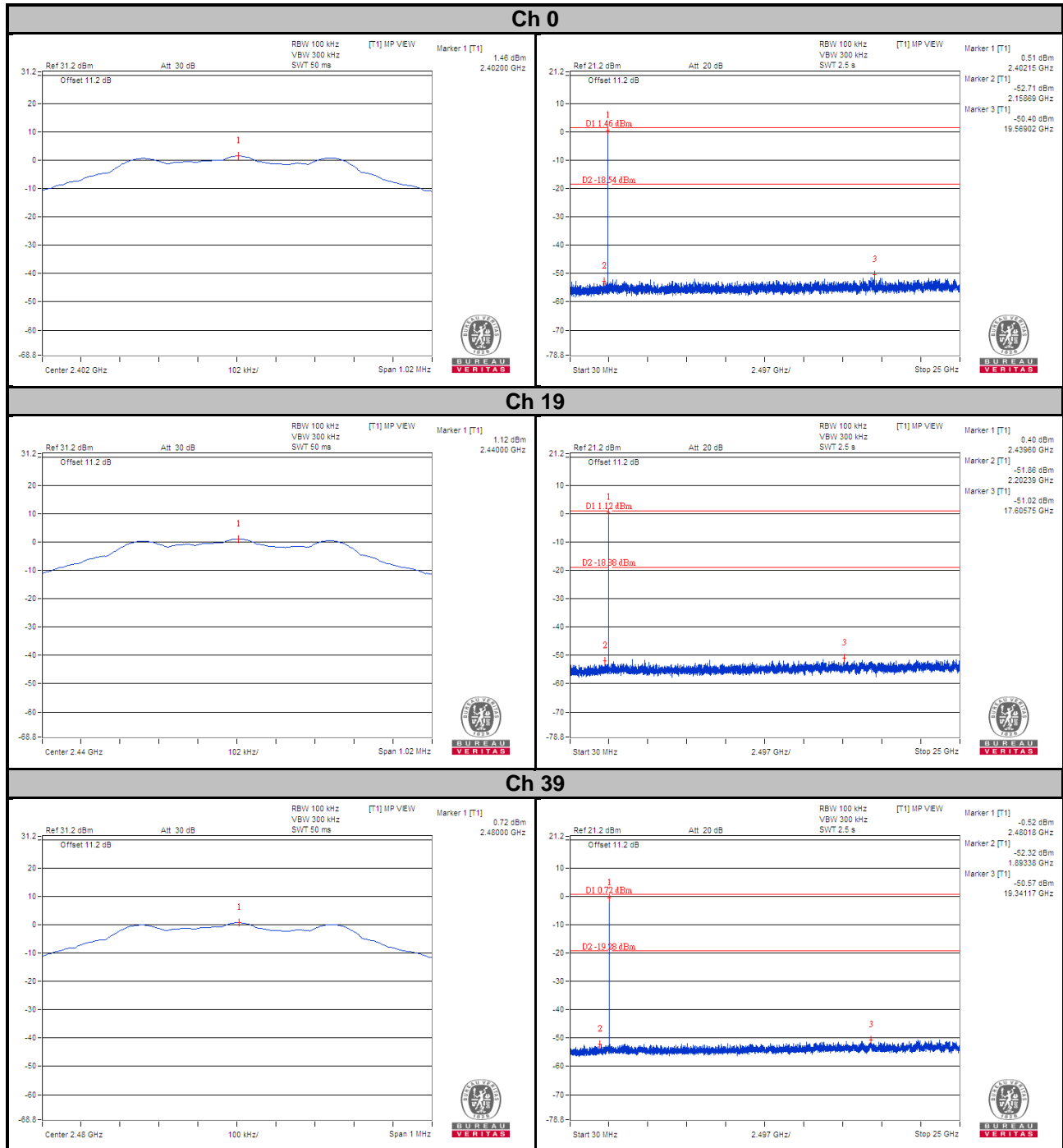

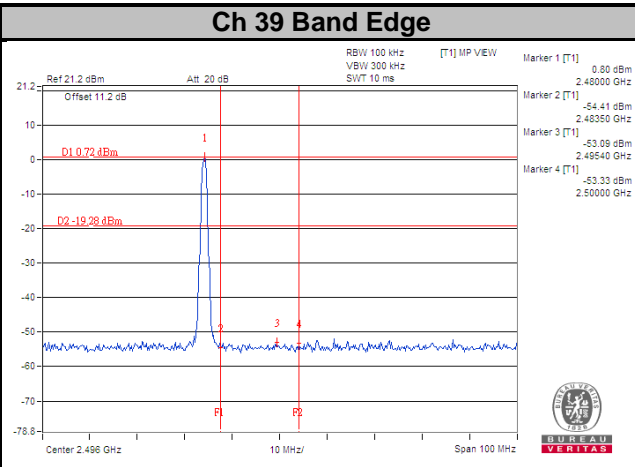
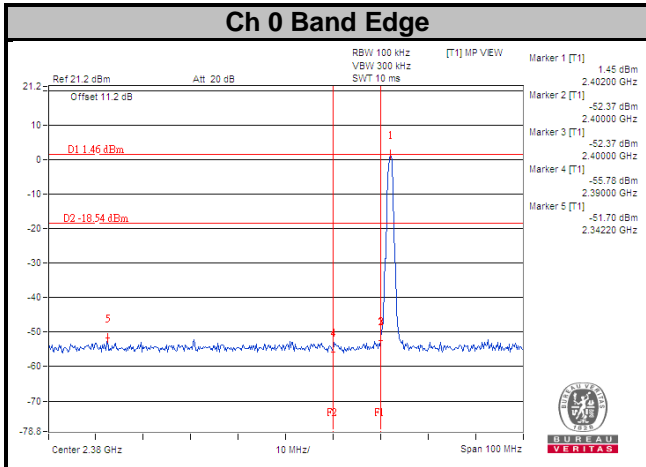

<WLAN>

#### 4.17 Radiated Emission and Bandedge Measurement

##### 4.17.1 Limits of Radiated Emission and Bandedge Measurement

Radiated emissions which fall in the restricted bands must comply with the radiated emission limits specified as below table. Other emissions shall be at least 20 dB below the highest level of the desired power:

Frequencies (MHz)	Field Strength (microvolts/meter)	Measurement Distance (meters)
0.009 ~ 0.490	2400/F (kHz)	300
0.490 ~ 1.705	24000/F (kHz)	30
1.705 ~ 30.0	30	30
30 ~ 88	100	3
88 ~ 216	150	3
216 ~ 960	200	3
Above 960	500	3

**NOTE:**

1. The lower limit shall apply at the transition frequencies.
2. Emission level (dBuV/m) = 20 log Emission level (uV/m).
3. For frequencies above 1000 MHz, the field strength limits are based on average detector, however, the peak field strength of any emission shall not exceed the maximum permitted average limits, specified above by more than 20 dB under any condition of modulation.

##### 4.17.2 Test Instruments

Refer to section 4.1.2 to get information of the instrument.

#### 4.17.3 Test Procedures

##### **For Radiated Emission below 30 MHz**

- a. The EUT was placed on the top of a rotating table 0.8 meters above the ground at a 3 meter chamber room. The table was rotated 360 degrees to determine the position of the highest radiation.
- b. The EUT was set 3 meters away from the interference-receiving antenna, which was mounted on the top of a variable-height antenna tower.
- c. Parallel, perpendicular, and ground-parallel orientations of the antenna are set to make the measurement.
- d. For each suspected emission, the EUT was arranged to its worst case and the rotatable table was turned from 0 degrees to 360 degrees to find the maximum reading.
- e. The test-receiver system was set to Quasi-Peak Detect Function and Specified Bandwidth with Maximum Hold Mode.

##### **Note:**

1. The resolution bandwidth and video bandwidth of test receiver/spectrum analyzer is 9 kHz at frequency below 30 MHz.
2. There is a comparison data of both open-field test site and semi-Anechoic chamber, and the result came out very similar.

##### **For Radiated Emission above 30 MHz**

- a. The EUT was placed on the top of a rotating table 0.8 meters (for 30 MHz ~ 1 GHz) / 1.5 meters (for above 1 GHz) above the ground at 3 meter chamber room for test. The table was rotated 360 degrees to determine the position of the highest radiation.
- b. The EUT was set 3 meters away from the interference-receiving antenna, which was mounted on the top of a variable-height antenna tower.
- c. The height of antenna is varied from one meter to four meters above the ground to determine the maximum value of the field strength. Both horizontal and vertical polarizations of the antenna are set to make the measurement.
- d. For each suspected emission, the EUT was arranged to its worst case and then the antenna was tuned to heights from 1 meter to 4 meters and the rotatable table was turned from 0 degrees to 360 degrees to find the maximum reading.
- e. The test-receiver system was set to quasi-peak detect function and specified bandwidth with maximum hold mode when the test frequency is below 1 GHz.
- f. The test-receiver system was set to peak and average detected function and specified bandwidth with maximum hold mode when the test frequency is above 1 GHz. If the peak reading value also meets average limit, measurement with the average detector is unnecessary.

##### **Note:**

1. The resolution bandwidth and video bandwidth of test receiver/spectrum analyzer is 120 kHz for Quasi-peak detection (QP) at frequency below 1 GHz.
2. The resolution bandwidth of test receiver/spectrum analyzer is 1 MHz and the video bandwidth is 3 MHz for Peak detection (PK) at frequency above 1 GHz.
3. The resolution bandwidth of test receiver/spectrum analyzer is 1 MHz and the video bandwidth is  $\geq 1/T$  (Duty cycle < 98 %) or 10 Hz (Duty cycle  $\geq 98$  %) for Average detection (AV) at frequency above 1 GHz.  
(11b: RBW = 1 MHz, VBW = 300 Hz ; 11g: RBW = 1 MHz, VBW = 1 kHz ;  
11n (HT20): RBW = 1 MHz, VBW = 1 kHz)
4. All modes of operation were investigated and the worst-case emissions are reported.



4.17.4 Deviation from Test Standard

No deviation.

4.17.5 Test Set Up

<Radiated Emission below 30 MHz>

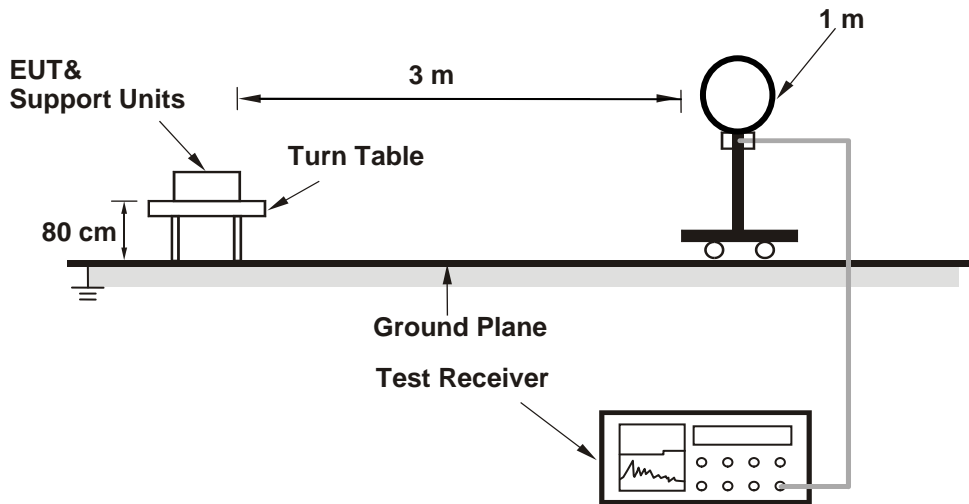

<Radiated Emission 30 MHz to 1 GHz>

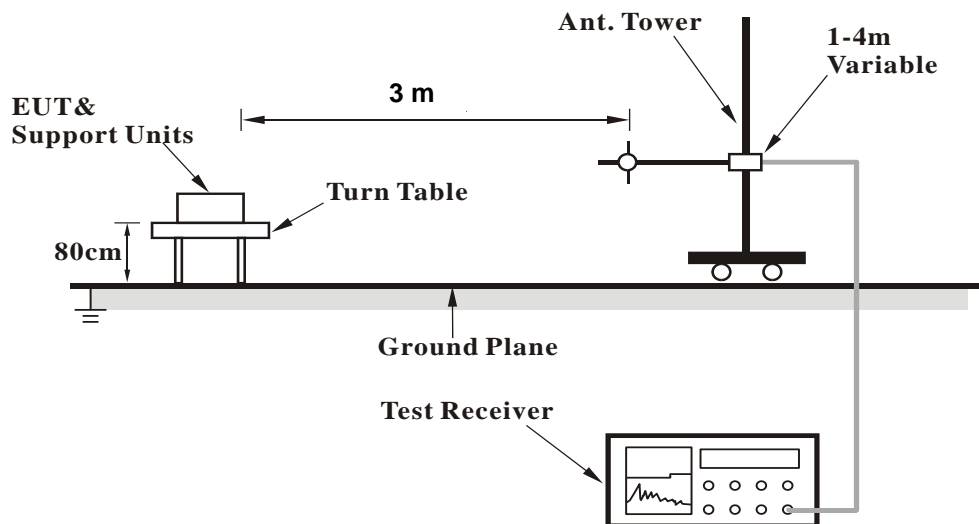

### <Radiated Emission above 1 GHz>

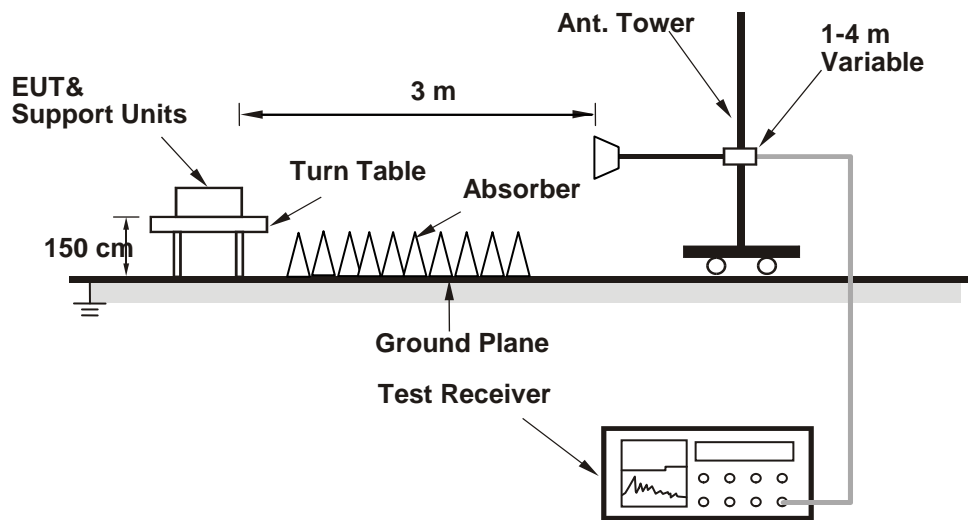

For the actual test configuration, please refer to the attached file (Test Setup Photo).

#### 4.17.6 EUT Operating Conditions

- Placed the EUT on a testing table.
- Use the software to control the EUT under transmission condition continuously at specific channel frequency.

4.17.7 Test Results

Above 1 GHz Data :

Mode A

802.11b

EUT Test Condition		Measurement Detail	
Channel	Channel 1	Frequency Range	1 GHz ~ 25 GHz
Input Power	120 Vac, 60 Hz	Detector Function	Peak (PK) Average (AV)
Environmental Conditions	25 deg. C, 65 % RH	Tested By	Thomas Wei

Horizontal

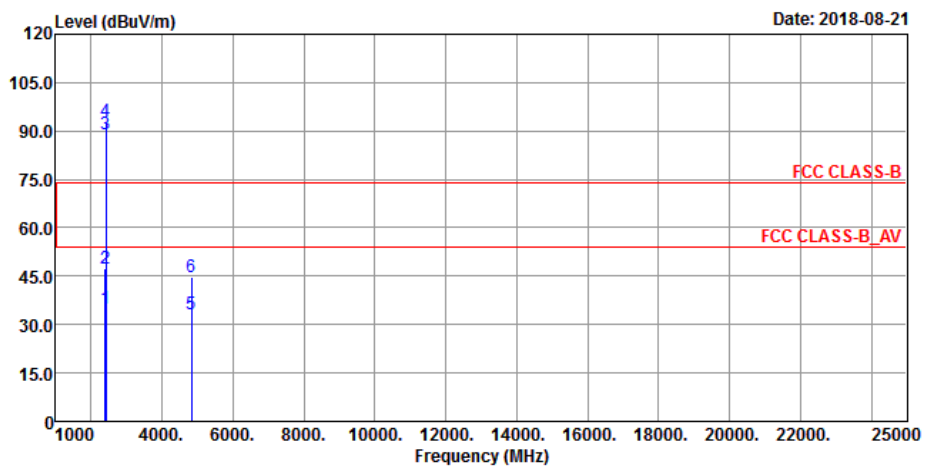

Vertical

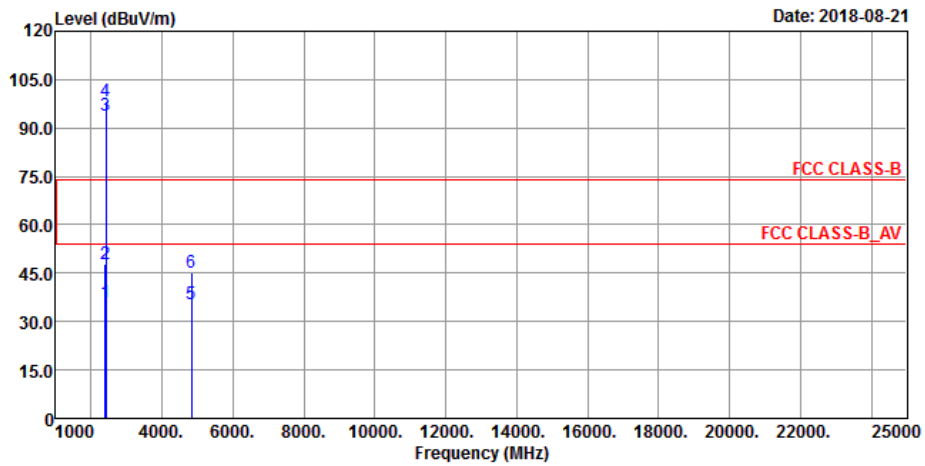

Antenna Polarity & Test Distance: Horizontal at 3 m										
Frequency (MHz)	Emission Level (dBuV/m)	Read Level (dBuV)	Limit (dBuV/m)	Margin (dB)	Antenna Factor (dB/m)	Cable Loss (dB)	Preamp Factor (dB)	Antenna Height (cm)	Table Angle (Degree)	Remark
2388.29	35.13	41.2	54	-18.87	27.08	4.35	37.5	122	239	Average
2388.29	47.16	53.23	74	-26.84	27.08	4.35	37.5	122	239	Peak
2412	89.08	94.99			27.23	4.38	37.52	122	239	Average
2412	93.03	98.94			27.23	4.38	37.52	122	239	Peak
4824	33.01	47.92	54	-20.99	31.17	6.81	52.89	118	233	Average
4824	44.94	59.85	74	-29.06	31.17	6.81	52.89	118	233	Peak
Antenna Polarity & Test Distance: Vertical at 3 m										
Frequency (MHz)	Emission Level (dBuV/m)	Read Level (dBuV)	Limit (dBuV/m)	Margin (dB)	Antenna Factor (dB/m)	Cable Loss (dB)	Preamp Factor (dB)	Antenna Height (cm)	Table Angle (Degree)	Remark
2389.8	36.01	41.99	54	-17.99	27.16	4.36	37.5	114	81	Average
2389.8	47.95	53.93	74	-26.05	27.16	4.36	37.5	114	81	Peak
2412	93.71	99.62			27.23	4.38	37.52	114	81	Average
2412	98.26	104.17			27.23	4.38	37.52	114	81	Peak
4824	35.64	50.55	54	-18.36	31.17	6.81	52.89	148	315	Average
4824	45.38	60.29	74	-28.62	31.17	6.81	52.89	148	315	Peak

Remarks:

1. Emission Level = Read Level + Antenna Factor + Cable Loss - Preamp Factor  
Margin value = Emission level – Limit value
2. 2412 MHz: Fundamental frequency.
3. The other emission levels were very low against the limit.

EUT Test Condition		Measurement Detail	
Channel	Channel 6	Frequency Range	1 GHz ~ 25 GHz
Input Power	120 Vac, 60 Hz	Detector Function	Peak (PK) Average (AV)
Environmental Conditions	25 deg. C, 65 % RH	Tested By	Thomas Wei

### Horizontal

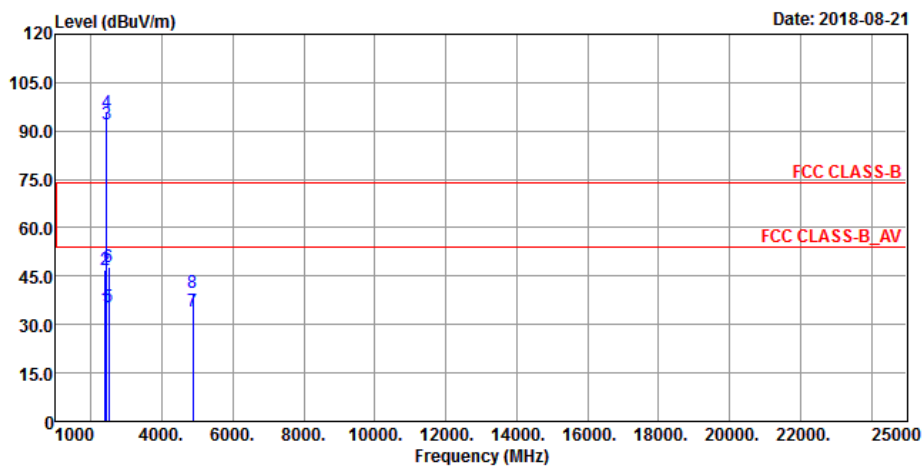

### Vertical

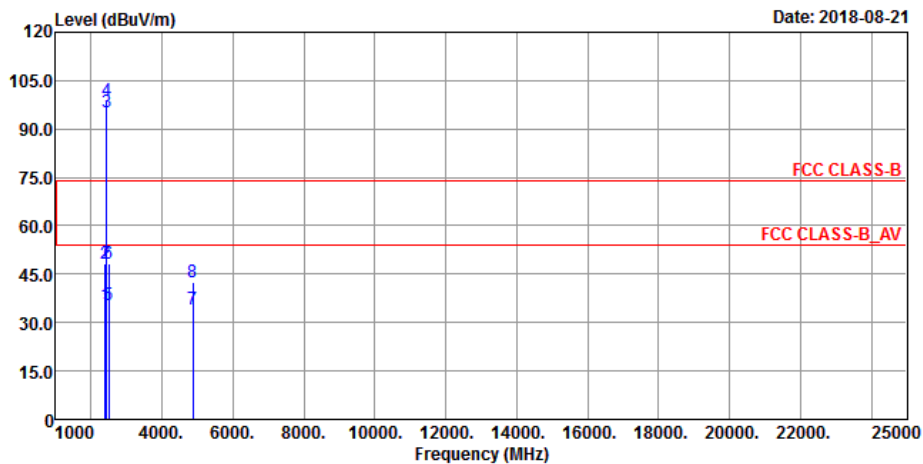

Antenna Polarity & Test Distance: Horizontal at 3 m										
Frequency (MHz)	Emission Level (dBuV/m)	Read Level (dBuV)	Limit (dBuV/m)	Margin (dB)	Antenna Factor (dB/m)	Cable Loss (dB)	Preamp Factor (dB)	Antenna Height (cm)	Table Angle (Degree)	Remark
2386.22	35.09	41.16	54	-18.91	27.08	4.35	37.5	167	219	Average
2386.22	46.95	53.02	74	-27.05	27.08	4.35	37.5	167	219	Peak
2437	91.93	97.61			27.38	4.4	37.46	167	219	Average
2437	95.82	101.5			27.38	4.4	37.46	167	219	Peak
2486.09	35.45	40.65	54	-18.55	27.61	4.44	37.25	167	219	Average
2499.08	47.77	52.97	74	-26.23	27.61	4.44	37.25	167	219	Peak
4874	34.06	48.81	54	-19.94	31.25	6.86	52.86	132	166	Average
4874	39.97	54.72	74	-34.03	31.25	6.86	52.86	132	166	Peak

Antenna Polarity & Test Distance: Vertical at 3 m										
Frequency (MHz)	Emission Level (dBuV/m)	Read Level (dBuV)	Limit (dBuV/m)	Margin (dB)	Antenna Factor (dB/m)	Cable Loss (dB)	Preamp Factor (dB)	Antenna Height (cm)	Table Angle (Degree)	Remark
2384.29	35.54	41.61	54	-18.46	27.08	4.35	37.5	164	86	Average
2384.29	48.27	54.34	74	-25.73	27.08	4.35	37.5	164	86	Peak
2437	95.33	101.01			27.38	4.4	37.46	164	86	Average
2437	98.78	104.46			27.38	4.4	37.46	164	86	Peak
2499.18	35.46	40.67	54	-18.54	27.61	4.43	37.25	164	86	Average
2499.18	48.15	53.36	74	-25.85	27.61	4.43	37.25	164	86	Peak
4874	34	48.75	54	-20	31.25	6.86	52.86	127	58	Average
4874	42.61	57.36	74	-31.39	31.25	6.86	52.86	127	58	Peak

Remarks:

- Emission Level = Read Level + Antenna Factor + Cable Loss - Preamp Factor  
Margin value = Emission level – Limit value
- 2437 MHz: Fundamental frequency.
- The other emission levels were very low against the limit.

EUT Test Condition		Measurement Detail	
Channel	Channel 11	Frequency Range	1 GHz ~ 25 GHz
Input Power	120 Vac, 60 Hz	Detector Function	Peak (PK) Average (AV)
Environmental Conditions	25 deg. C, 65 % RH	Tested By	Thomas Wei

### Horizontal

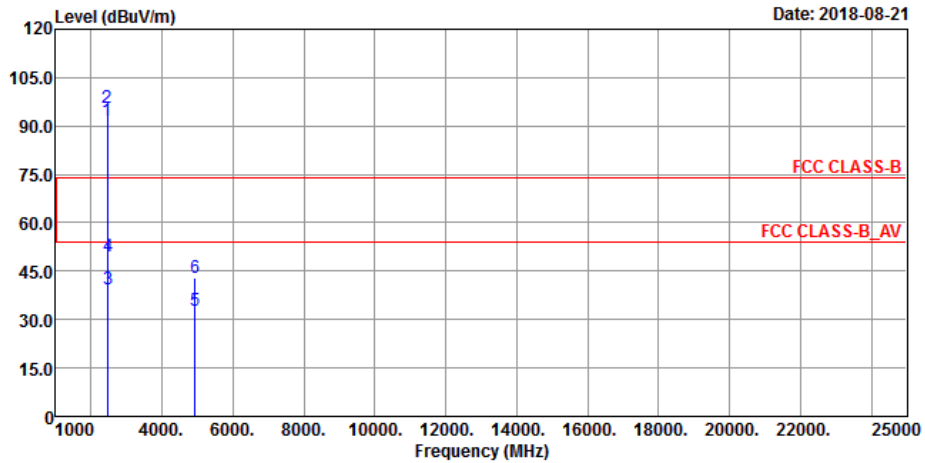

### Vertical

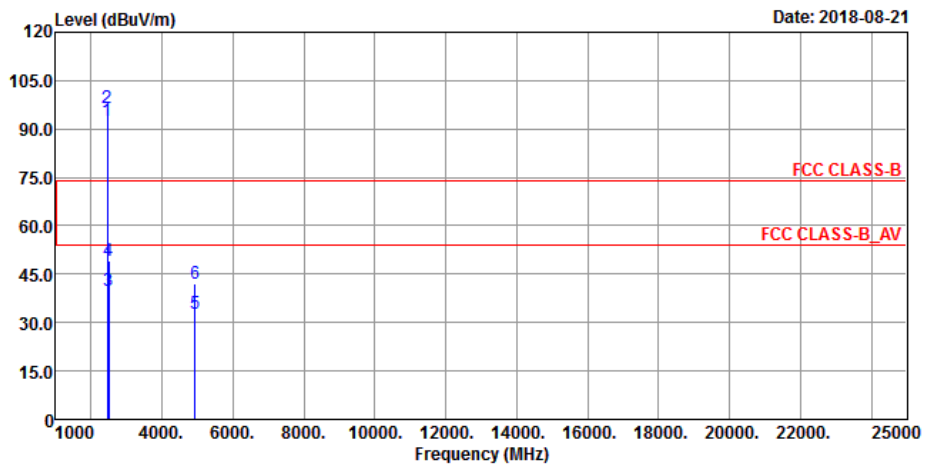

**Antenna Polarity & Test Distance: Horizontal at 3 m**

Frequency (MHz)	Emission Level (dBuV/m)	Read Level (dBuV)	Limit (dBuV/m)	Margin (dB)	Antenna Factor (dB/m)	Cable Loss (dB)	Preamp Factor (dB)	Antenna Height (cm)	Table Angle (Degree)	Remark
2462	91.64	97.16			27.46	4.41	37.39	129	213	Average
2462	95.75	101.27			27.46	4.41	37.39	127	213	Peak
2483.94	39.29	44.57	54	-14.71	27.61	4.43	37.32	129	213	Average
2483.94	49.49	54.77	74	-24.51	27.61	4.43	37.32	129	213	Peak
4924	32.62	47.28	54	-21.38	31.34	6.89	52.89	171	222	Average
4924	42.86	57.52	74	-31.14	31.34	6.89	52.89	171	222	Peak

**Antenna Polarity & Test Distance: Vertical at 3 m**

Frequency (MHz)	Emission Level (dBuV/m)	Read Level (dBuV)	Limit (dBuV/m)	Margin (dB)	Antenna Factor (dB/m)	Cable Loss (dB)	Preamp Factor (dB)	Antenna Height (cm)	Table Angle (Degree)	Remark
2462	92.37	97.89			27.46	4.41	37.39	139	71	Average
2462	96.47	101.99			27.46	4.41	37.39	139	71	Peak
2491	39.81	45.09	54	-14.19	27.61	4.43	37.32	139	71	Average
2491	49.26	54.54	74	-24.74	27.61	4.43	37.32	139	71	Peak
4924	32.57	47.23	54	-21.43	31.34	6.89	52.89	126	181	Average
4924	42.16	56.82	74	-31.84	31.34	6.89	52.89	126	181	Peak

**Remarks:**

1. Emission Level = Read Level + Antenna Factor + Cable Loss - Preamp Factor  
Margin value = Emission level – Limit value
2. 2462 MHz: Fundamental frequency.
3. The other emission levels were very low against the limit.



EUT Test Condition		Measurement Detail	
Channel	Channel 12	Frequency Range	1 GHz ~ 25 GHz
Input Power	120 Vac, 60 Hz	Detector Function	Peak (PK) Average (AV)
Environmental Conditions	25 deg. C, 65 % RH	Tested By	Thomas Wei

**Horizontal**

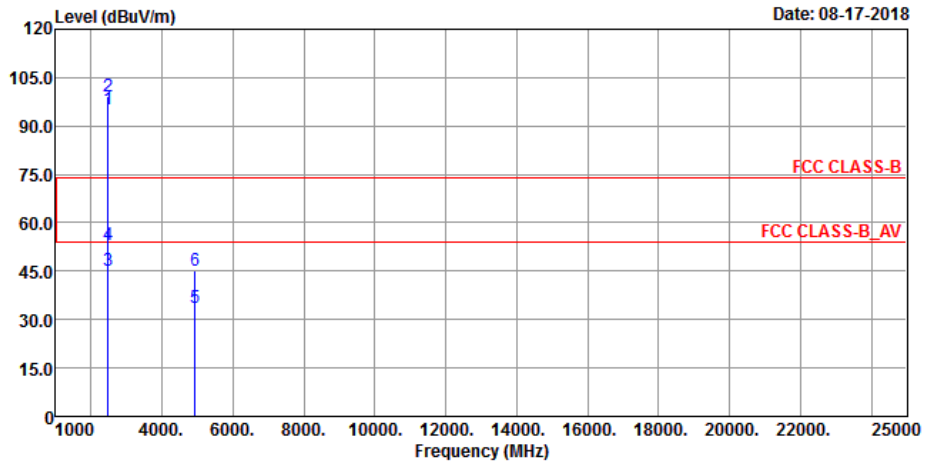

**Vertical**

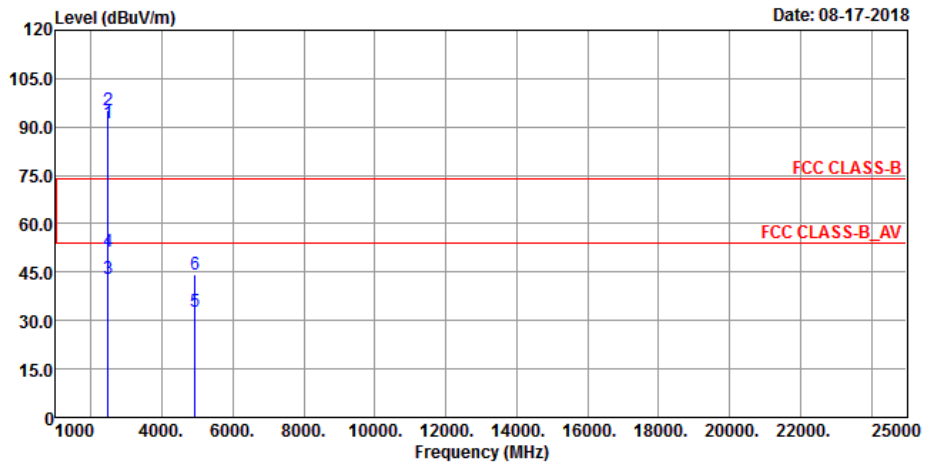

Antenna Polarity & Test Distance: Horizontal at 3 m										
Frequency (MHz)	Emission Level (dBuV/m)	Read Level (dBuV)	Limit (dBuV/m)	Margin (dB)	Antenna Factor (dB/m)	Cable Loss (dB)	Preamp Factor (dB)	Antenna Height (cm)	Table Angle (Degree)	Remark
2467	95.39	100.83			27.46	4.42	37.32	143	185	Average
2467	99.28	104.72			27.46	4.42	37.32	143	185	Peak
2483.52	45.35	50.71	54	-8.65	27.53	4.43	37.32	143	185	Average
2483.52	53.05	58.41	74	-20.95	27.53	4.43	37.32	143	185	Peak
4934	33.64	48.3	54	-20.36	31.34	6.89	52.89	172	68	Average
4934	45.36	60.02	74	-28.64	31.34	6.89	52.89	172	68	Peak
Antenna Polarity & Test Distance: Vertical at 3 m										
Frequency (MHz)	Emission Level (dBuV/m)	Read Level (dBuV)	Limit (dBuV/m)	Margin (dB)	Antenna Factor (dB/m)	Cable Loss (dB)	Preamp Factor (dB)	Antenna Height (cm)	Table Angle (Degree)	Remark
2467	91.33	96.77			27.46	4.42	37.32	210	199	Average
2467	95.24	100.68			27.46	4.42	37.32	210	199	Peak
2483.52	42.88	48.24	54	-11.12	27.53	4.43	37.32	210	199	Average
2483.52	51.24	56.6	74	-22.76	27.53	4.43	37.32	210	199	Peak
4934	32.87	47.53	54	-21.13	31.34	6.89	52.89	121	249	Average
4934	44.13	58.79	74	-29.87	31.34	6.89	52.89	121	249	Peak

Remarks:

1. Emission Level = Read Level + Antenna Factor + Cable Loss - Preamp Factor  
Margin value = Emission level – Limit value
2. 2467 MHz: Fundamental frequency.
3. The other emission levels were very low against the limit.

EUT Test Condition		Measurement Detail	
Channel	Channel 13	Frequency Range	1 GHz ~ 25 GHz
Input Power	120 Vac, 60 Hz	Detector Function	Peak (PK) Average (AV)
Environmental Conditions	25 deg. C, 65 % RH	Tested By	Thomas Wei

### Horizontal

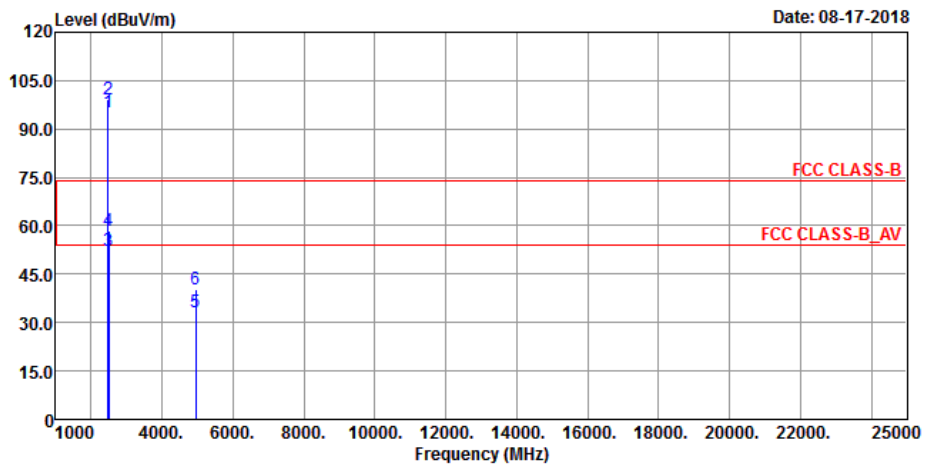

### Vertical

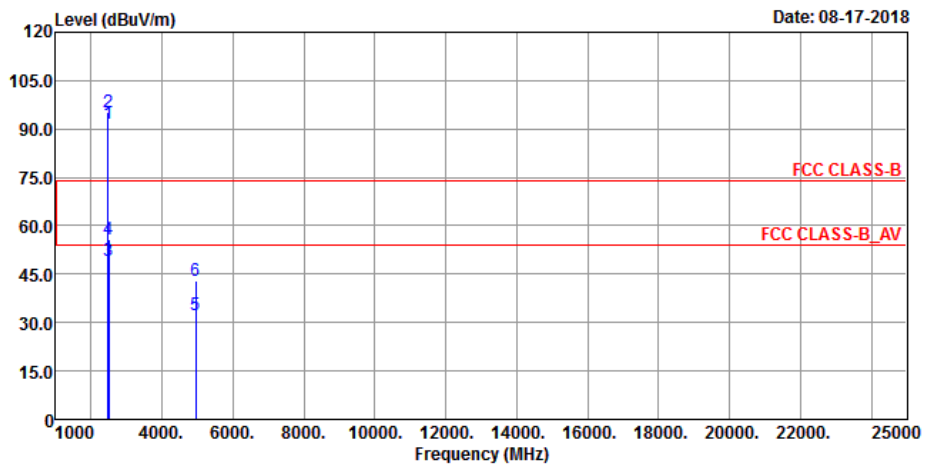

Antenna Polarity & Test Distance: Horizontal at 3 m										
Frequency (MHz)	Emission Level (dBUV/m)	Read Level (dBUV)	Limit (dBUV/m)	Margin (dB)	Antenna Factor (dB/m)	Cable Loss (dB)	Preamp Factor (dB)	Antenna Height (cm)	Table Angle (Degree)	Remark
2472	95.2	100.57			27.53	4.42	37.32	178	186	Average
2472	99	104.37			27.53	4.42	37.32	178	186	Peak
2485.24	52.29	57.65	54	-1.71	27.53	4.43	37.32	178	186	Average
2485.24	58.27	63.63	74	-15.73	27.53	4.43	37.32	178	186	Peak
4944	33.19	48.55	54	-20.81	31.37	6.19	52.92	158	239	Average
4944	40.19	55.55	74	-33.81	31.37	6.19	52.92	158	239	Peak
Antenna Polarity & Test Distance: Vertical at 3 m										
Frequency (MHz)	Emission Level (dBUV/m)	Read Level (dBUV)	Limit (dBUV/m)	Margin (dB)	Antenna Factor (dB/m)	Cable Loss (dB)	Preamp Factor (dB)	Antenna Height (cm)	Table Angle (Degree)	Remark
2472	91.55	96.92			27.53	4.42	37.32	117	333	Average
2472	95.39	100.76			27.53	4.42	37.32	117	333	Peak
2485.28	49.15	54.51	54	-4.85	27.53	4.43	37.32	117	333	Average
2485.28	55.98	61.34	74	-18.02	27.53	4.43	37.32	117	333	Peak
4944	32.49	47.85	54	-21.51	31.37	6.19	52.92	123	49	Average
4944	43.03	58.39	74	-30.97	31.37	6.19	52.92	123	49	Peak

Remarks:

1. Emission Level = Read Level + Antenna Factor + Cable Loss - Preamp Factor  
Margin value = Emission level – Limit value
2. 2472 MHz: Fundamental frequency.
3. The other emission levels were very low against the limit.

802.11g

EUT Test Condition		Measurement Detail	
Channel	Channel 1	Frequency Range	1 GHz ~ 25 GHz
Input Power	120 Vac, 60 Hz	Detector Function	Peak (PK) Average (AV)
Environmental Conditions	25 deg. C, 65 % RH	Tested By	Thomas Wei

Horizontal

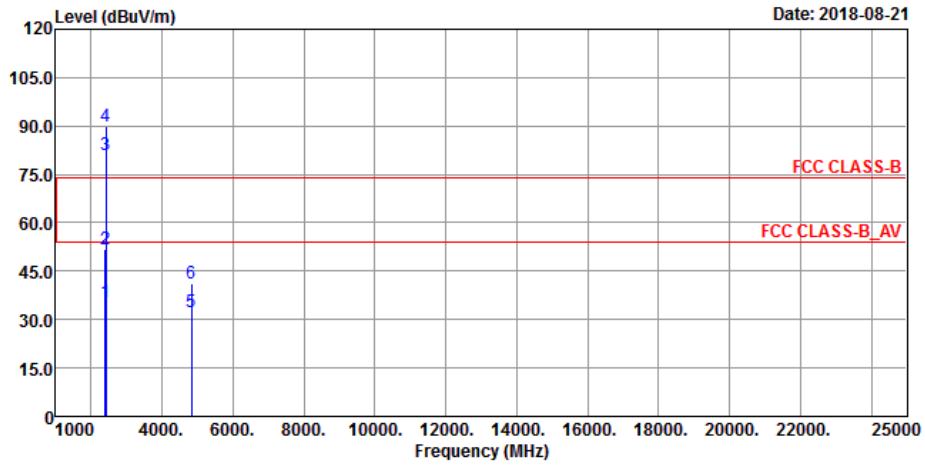

Vertical

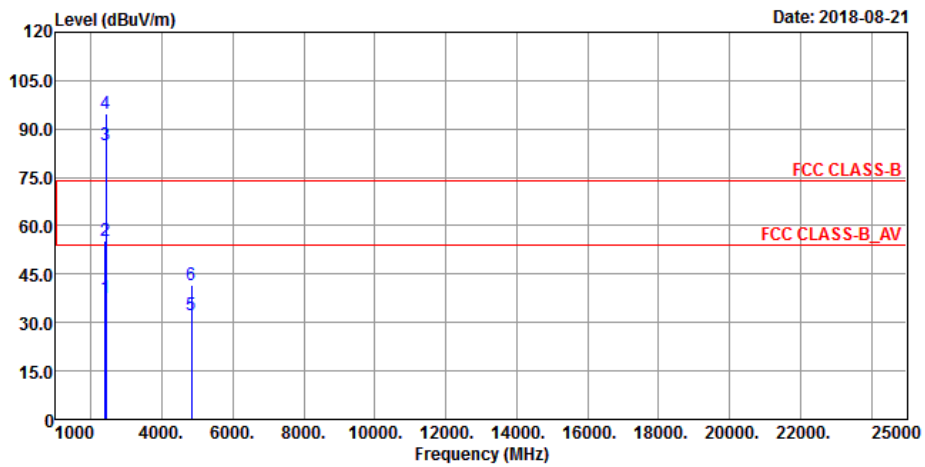

Antenna Polarity & Test Distance: Horizontal at 3 m										
Frequency (MHz)	Emission Level (dBuV/m)	Read Level (dBuV)	Limit (dBuV/m)	Margin (dB)	Antenna Factor (dB/m)	Cable Loss (dB)	Preamp Factor (dB)	Antenna Height (cm)	Table Angle (Degree)	Remark
2389.87	35.48	41.48	54	-18.52	27.16	4.36	37.52	154	276	Average
2389.87	51.69	57.69	74	-22.31	27.16	4.36	37.52	154	276	Peak
2412	80.91	86.82			27.23	4.38	37.52	154	276	Average
2412	90.07	95.98			27.23	4.38	37.52	154	276	Peak
4824	32.31	47.22	54	-21.69	31.17	6.81	52.89	133	167	Average
4824	41.01	55.92	74	-32.99	31.17	6.81	52.89	133	167	Peak
Antenna Polarity & Test Distance: Vertical at 3 m										
Frequency (MHz)	Emission Level (dBuV/m)	Read Level (dBuV)	Limit (dBuV/m)	Margin (dB)	Antenna Factor (dB/m)	Cable Loss (dB)	Preamp Factor (dB)	Antenna Height (cm)	Table Angle (Degree)	Remark
2389.94	37.43	43.43	54	-16.57	27.16	4.36	37.52	166	113	Average
2389.94	55.49	61.49	74	-18.51	27.16	4.36	37.52	166	113	Peak
2412	84.98	90.89			27.23	4.38	37.52	166	113	Average
2412	94.72	100.63			27.23	4.38	37.52	166	113	Peak
4824	32.48	47.39	54	-21.52	31.17	6.81	52.89	122	181	Average
4824	41.55	56.46	74	-32.45	31.17	6.81	52.89	122	181	Peak

Remarks:

1. Emission Level = Read Level + Antenna Factor + Cable Loss - Preamp Factor  
Margin value = Emission level – Limit value
2. 2412 MHz: Fundamental frequency.
3. The other emission levels were very low against the limit.

EUT Test Condition		Measurement Detail	
Channel	Channel 6	Frequency Range	1 GHz ~ 25 GHz
Input Power	120 Vac, 60 Hz	Detector Function	Peak (PK) Average (AV)
Environmental Conditions	25 deg. C, 65 % RH	Tested By	Thomas Wei

### Horizontal

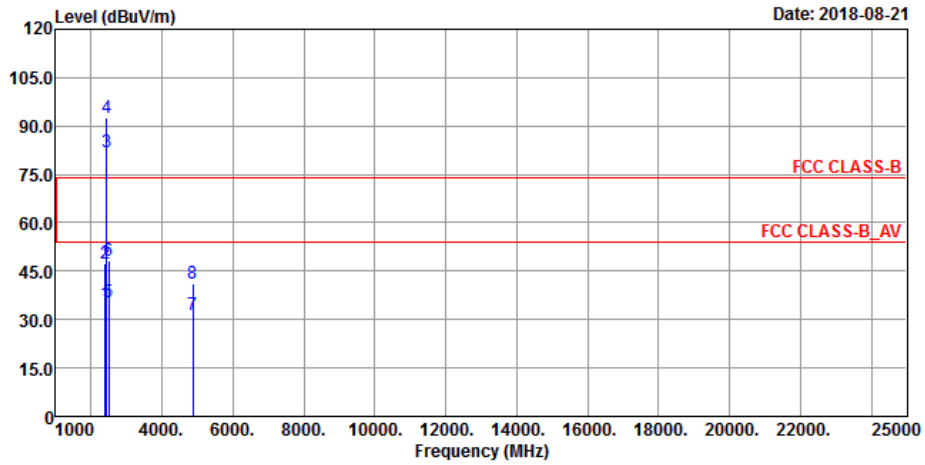

### Vertical

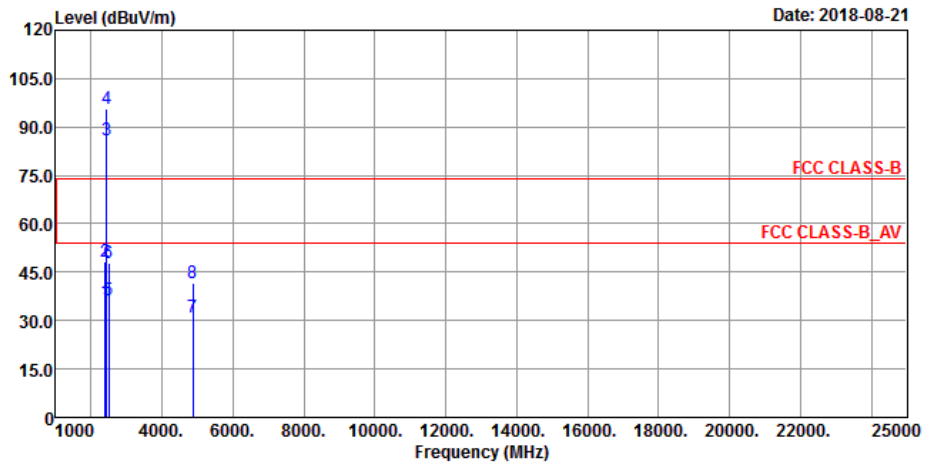

**Antenna Polarity & Test Distance: Horizontal at 3 m**

Frequency (MHz)	Emission Level (dBuV/m)	Read Level (dBuV)	Limit (dBuV/m)	Margin (dB)	Antenna Factor (dB/m)	Cable Loss (dB)	Preamp Factor (dB)	Antenna Height (cm)	Table Angle (Degree)	Remark
2384.89	34.82	40.89	54	-19.18	27.08	4.35	37.5	174	159	Average
2384.89	47.35	53.42	74	-26.65	27.08	4.35	37.5	174	159	Peak
2437	81.79	87.47			27.38	4.4	37.46	174	159	Average
2437	92.43	98.11			27.38	4.4	37.46	174	159	Peak
2490.58	35.46	40.74	54	-18.54	27.61	4.43	37.32	174	159	Average
2490.58	48.38	53.66	74	-25.62	27.61	4.43	37.32	174	159	Peak
4874	31.27	46.73	54	-22.73	31.25	6.15	52.86	129	117	Average
4874	41.03	56.49	74	-32.97	31.25	6.15	52.86	127	117	Peak

**Antenna Polarity & Test Distance: Vertical at 3 m**

Frequency (MHz)	Emission Level (dBuV/m)	Read Level (dBuV)	Limit (dBuV/m)	Margin (dB)	Antenna Factor (dB/m)	Cable Loss (dB)	Preamp Factor (dB)	Antenna Height (cm)	Table Angle (Degree)	Remark
2386.49	36.05	42.12	54	-17.95	27.08	4.35	37.5	157	326	Average
2386.49	48.28	54.35	74	-25.72	27.08	4.35	37.5	157	326	Peak
2437	86.09	91.77			27.38	4.4	37.46	157	326	Average
2437	95.86	101.54			27.38	4.4	37.46	157	326	Peak
2495.11	36.19	41.47	54	-17.81	27.61	4.43	37.32	157	326	Average
2495.11	47.82	53.1	74	-26.18	27.61	4.43	37.32	157	326	Peak
4874	30.92	46.38	54	-23.08	31.25	6.15	52.86	152	248	Average
4874	41.84	57.3	74	-32.16	31.25	6.15	52.86	152	248	Peak

Remarks:

- Emission Level = Read Level + Antenna Factor + Cable Loss - Preamp Factor  
Margin value = Emission level – Limit value
- 2437 MHz: Fundamental frequency.
- The other emission levels were very low against the limit.



EUT Test Condition		Measurement Detail	
Channel	Channel 11	Frequency Range	1 GHz ~ 25 GHz
Input Power	120 Vac, 60 Hz	Detector Function	Peak (PK) Average (AV)
Environmental Conditions	25 deg. C, 65 % RH	Tested By	Thomas Wei

### Horizontal

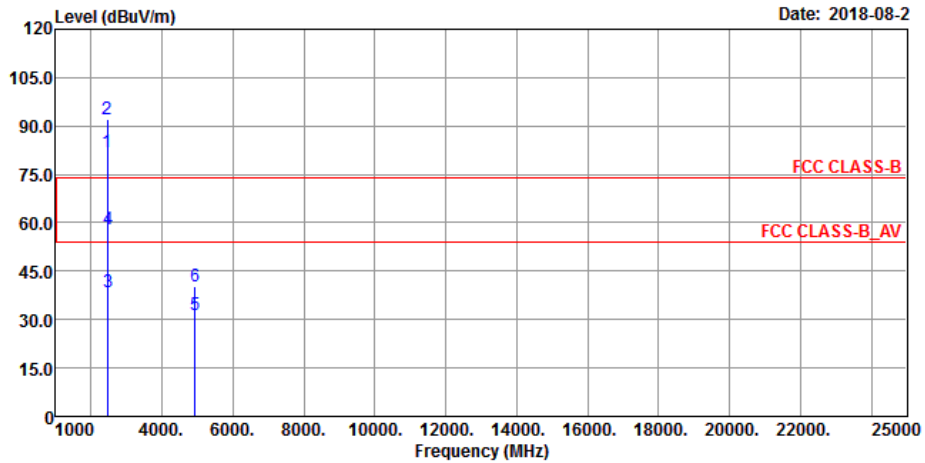

### Vertical

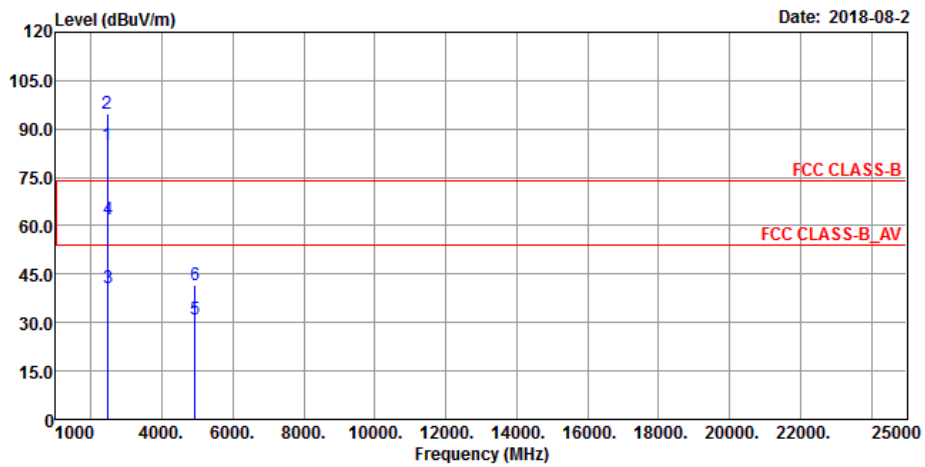

**Antenna Polarity & Test Distance: Horizontal at 3 m**

Frequency (MHz)	Emission Level (dBuV/m)	Read Level (dBuV)	Limit (dBuV/m)	Margin (dB)	Antenna Factor (dB/m)	Cable Loss (dB)	Preamp Factor (dB)	Antenna Height (cm)	Table Angle (Degree)	Remark
2462	82.02	87.54			27.46	4.41	37.39	143	198	Average
2462	91.91	97.43			27.46	4.41	37.39	143	198	Peak
2483.6	38.57	43.93	54	-15.43	27.53	4.43	37.32	143	198	Average
2483.6	58.09	63.45	74	-15.91	27.53	4.43	37.32	143	198	Peak
4924	31.38	46.74	54	-22.62	31.34	6.19	52.89	169	128	Average
4924	40.37	55.73	74	-33.63	31.34	6.19	52.89	169	128	Peak

**Antenna Polarity & Test Distance: Vertical at 3 m**

Frequency (MHz)	Emission Level (dBuV/m)	Read Level (dBuV)	Limit (dBuV/m)	Margin (dB)	Antenna Factor (dB/m)	Cable Loss (dB)	Preamp Factor (dB)	Antenna Height (cm)	Table Angle (Degree)	Remark
2462	84.97	90.49			27.46	4.41	37.39	154	113	Average
2462	94.63	100.15			27.46	4.41	37.39	154	113	Peak
2483.52	40.52	45.88	54	-13.48	27.53	4.43	37.32	154	113	Average
2483.52	61.96	67.32	74	-12.04	27.53	4.43	37.32	154	113	Peak
4924	31.1	46.46	54	-22.9	31.34	6.19	52.89	109	77	Average
4924	41.48	56.84	74	-32.52	31.34	6.19	52.89	109	77	Peak

**Remarks:**

- Emission Level = Read Level + Antenna Factor + Cable Loss - Preamp Factor  
Margin value = Emission level – Limit value
- 2462 MHz: Fundamental frequency.
- The other emission levels were very low against the limit.

EUT Test Condition		Measurement Detail	
Channel	Channel 12	Frequency Range	1 GHz ~ 25 GHz
Input Power	120 Vac, 60 Hz	Detector Function	Peak (PK) Average (AV)
Environmental Conditions	25 deg. C, 65 % RH	Tested By	Thomas Wei

### Horizontal

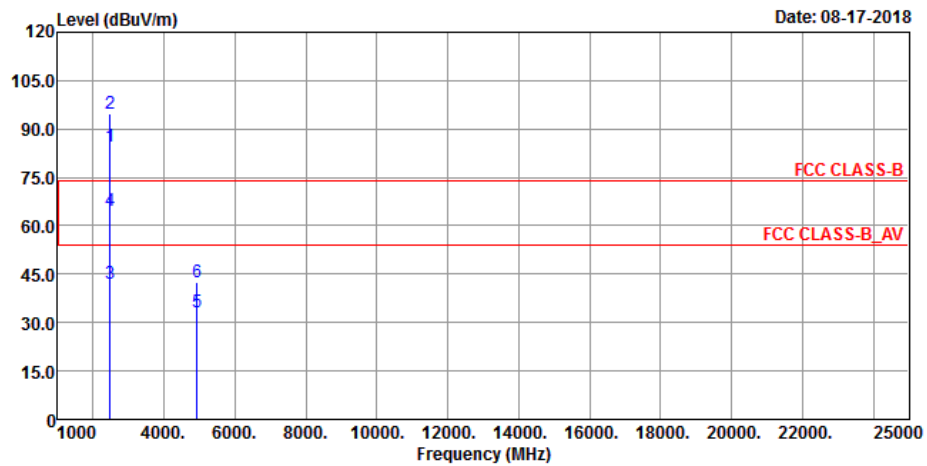

### Vertical

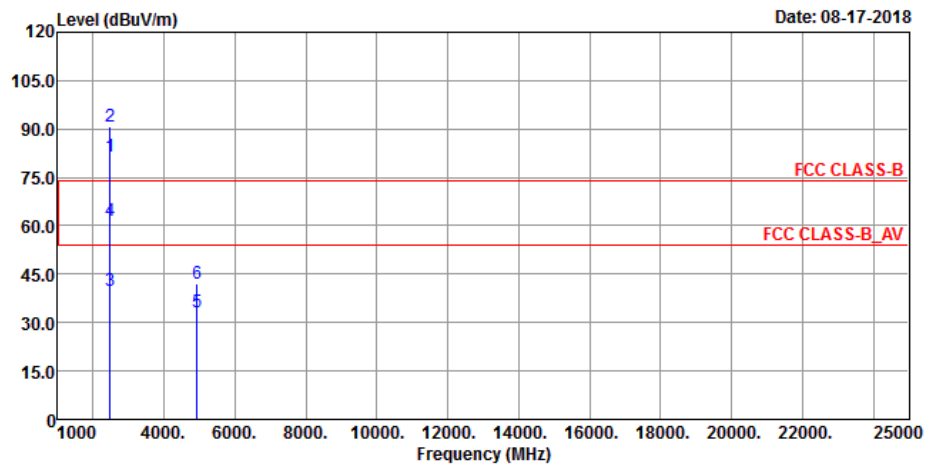

**Antenna Polarity & Test Distance: Horizontal at 3 m**

Frequency (MHz)	Emission Level (dBuV/m)	Read Level (dBuV)	Limit (dBuV/m)	Margin (dB)	Antenna Factor (dB/m)	Cable Loss (dB)	Preamp Factor (dB)	Antenna Height (cm)	Table Angle (Degree)	Remark
2467	84.75	90.19			27.46	4.42	37.32	127	184	Average
2467	94.55	99.99			27.46	4.42	37.32	127	184	Peak
2483.52	42.19	47.55	54	-11.81	27.53	4.43	37.32	127	184	Average
2483.52	64.46	69.82	74	-9.54	27.53	4.43	37.32	127	184	Peak
4934	33.06	47.72	54	-20.94	31.34	6.89	52.89	146	248	Average
4934	42.34	57	74	-31.66	31.34	6.89	52.89	146	248	Peak

**Antenna Polarity & Test Distance: Vertical at 3 m**

Frequency (MHz)	Emission Level (dBuV/m)	Read Level (dBuV)	Limit (dBuV/m)	Margin (dB)	Antenna Factor (dB/m)	Cable Loss (dB)	Preamp Factor (dB)	Antenna Height (cm)	Table Angle (Degree)	Remark
2467	81.41	86.85			27.46	4.42	37.32	119	335	Average
2467	90.95	96.39			27.46	4.42	37.32	119	335	Peak
2483.52	39.68	45.04	54	-14.32	27.53	4.43	37.32	119	335	Average
2483.52	61.52	66.88	74	-12.48	27.53	4.43	37.32	119	335	Peak
4934	33.26	47.92	54	-20.74	31.34	6.89	52.89	168	201	Average
4934	42.21	56.87	74	-31.79	31.34	6.89	52.89	168	201	Peak

**Remarks:**

- Emission Level = Read Level + Antenna Factor + Cable Loss - Preamp Factor  
Margin value = Emission level – Limit value
- 2467 MHz: Fundamental frequency.
- The other emission levels were very low against the limit.

EUT Test Condition		Measurement Detail	
Channel	Channel 13	Frequency Range	1 GHz ~ 25 GHz
Input Power	120 Vac, 60 Hz	Detector Function	Peak (PK) Average (AV)
Environmental Conditions	25 deg. C, 65 % RH	Tested By	Thomas Wei

### Horizontal

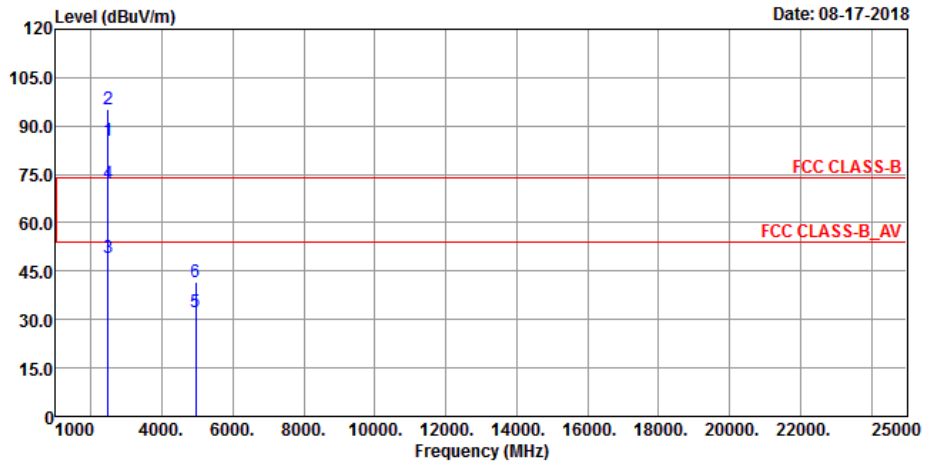

### Vertical

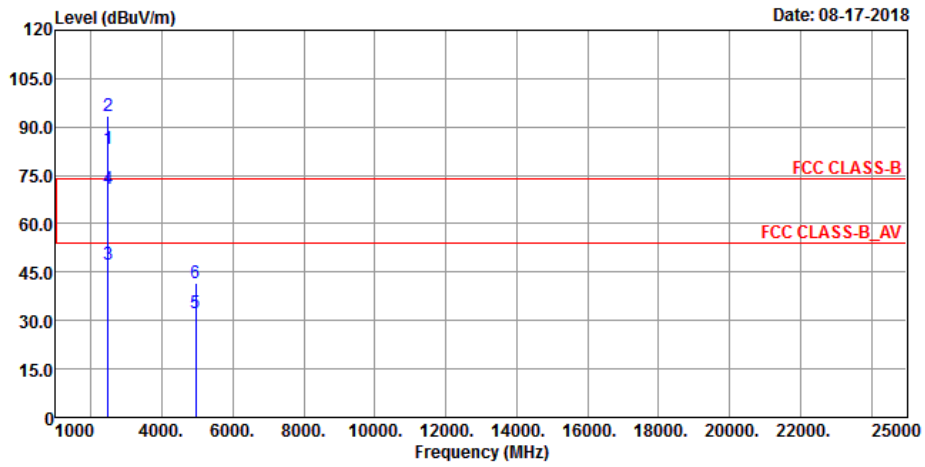

Antenna Polarity & Test Distance: Horizontal at 3 m										
Frequency (MHz)	Emission Level (dBuV/m)	Read Level (dBuV)	Limit (dBuV/m)	Margin (dB)	Antenna Factor (dB/m)	Cable Loss (dB)	Preamp Factor (dB)	Antenna Height (cm)	Table Angle (Degree)	Remark
2472	85.3	90.67			27.53	4.42	37.32	128	189	Average
2472	95.16	100.53			27.53	4.42	37.32	128	189	Peak
2483.52	49.22	54.58	54	-4.78	27.53	4.43	37.32	128	189	Average
2483.52	72.34	77.7	74	-1.66	27.53	4.43	37.32	128	189	Peak
4944	32.25	47.61	54	-21.75	31.37	6.19	52.92	162	321	Average
4944	41.81	57.17	74	-32.19	31.37	6.19	52.92	162	321	Peak
Antenna Polarity & Test Distance: Vertical at 3 m										
Frequency (MHz)	Emission Level (dBuV/m)	Read Level (dBuV)	Limit (dBuV/m)	Margin (dB)	Antenna Factor (dB/m)	Cable Loss (dB)	Preamp Factor (dB)	Antenna Height (cm)	Table Angle (Degree)	Remark
2472	83.42	88.79			27.53	4.42	37.32	174	356	Average
2472	93.38	98.75			27.53	4.42	37.32	174	356	Peak
2483.52	47.46	52.82	54	-6.54	27.53	4.43	37.32	174	356	Average
2483.52	70.67	76.03	74	-3.33	27.53	4.43	37.32	174	356	Peak
4944	32.45	47.81	54	-21.55	31.37	6.19	52.92	191	67	Average
4944	41.5	56.86	74	-32.5	31.37	6.19	52.92	191	67	Peak

Remarks:

1. Emission Level = Read Level + Antenna Factor + Cable Loss - Preamp Factor  
Margin value = Emission level – Limit value
2. 2472 MHz: Fundamental frequency.
3. The other emission levels were very low against the limit.

### 802.11n (HT20)

EUT Test Condition		Measurement Detail	
Channel	Channel 1	Frequency Range	1 GHz ~ 25 GHz
Input Power	120 Vac, 60 Hz	Detector Function	Peak (PK) Average (AV)
Environmental Conditions	25 deg. C, 65 % RH	Tested By	Thomas Wei

#### Horizontal

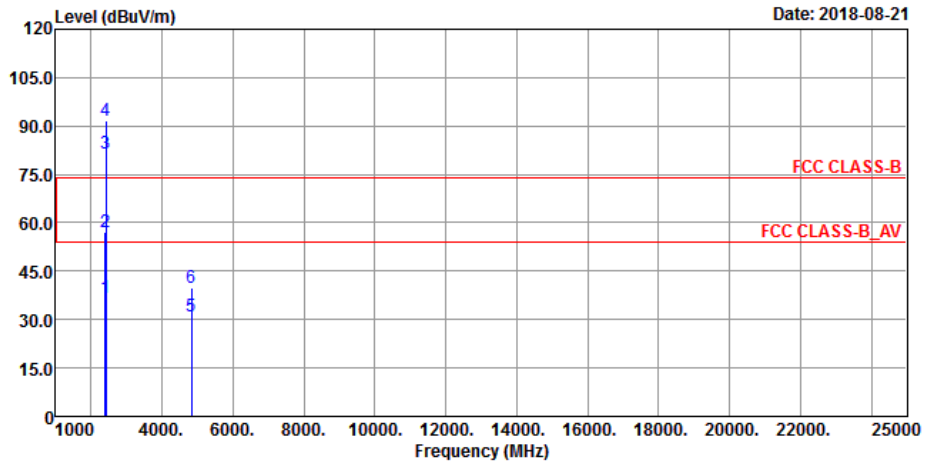

#### Vertical

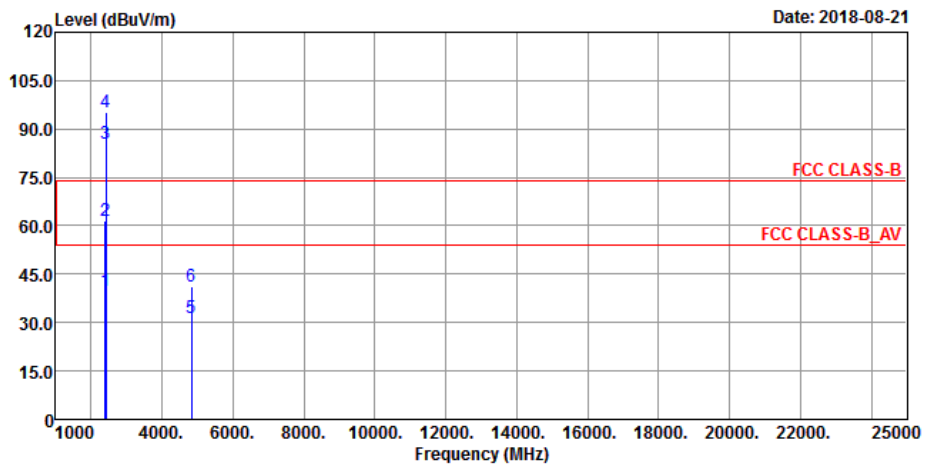

Antenna Polarity & Test Distance: Horizontal at 3 m										
Frequency (MHz)	Emission Level (dBuV/m)	Read Level (dBuV)	Limit (dBuV/m)	Margin (dB)	Antenna Factor (dB/m)	Cable Loss (dB)	Preamp Factor (dB)	Antenna Height (cm)	Table Angle (Degree)	Remark
2389.41	36.95	42.95	54	-17.05	27.16	4.36	37.52	139	204	Average
2389.41	57.05	63.05	74	-16.95	27.16	4.36	37.52	139	204	Peak
2412	81.51	87.42			27.23	4.38	37.52	139	204	Average
2412	91.56	97.47			27.23	4.38	37.52	139	204	Peak
4824	30.89	46.51	54	-23.11	31.17	6.1	52.89	187	239	Average
4824	39.64	55.26	74	-34.36	31.17	6.1	52.89	187	239	Peak
Antenna Polarity & Test Distance: Vertical at 3 m										
Frequency (MHz)	Emission Level (dBuV/m)	Read Level (dBuV)	Limit (dBuV/m)	Margin (dB)	Antenna Factor (dB/m)	Cable Loss (dB)	Preamp Factor (dB)	Antenna Height (cm)	Table Angle (Degree)	Remark
2389.94	39.95	45.95	54	-14.05	27.16	4.36	37.52	166	103	Average
2389.94	61.49	67.49	74	-12.51	27.16	4.36	37.52	166	103	Peak
2412	85.31	91.22			27.23	4.38	37.52	166	103	Average
2412	95.07	100.98			27.23	4.38	37.52	166	103	Peak
4824	31.39	47.01	54	-22.61	31.17	6.1	52.89	163	337	Average
4824	41.12	56.74	74	-32.88	31.17	6.1	52.89	163	337	Peak

Remarks:

1. Emission Level = Read Level + Antenna Factor + Cable Loss - Preamp Factor  
Margin value = Emission level – Limit value
2. 2412 MHz: Fundamental frequency.
3. The other emission levels were very low against the limit.



EUT Test Condition		Measurement Detail	
Channel	Channel 6	Frequency Range	1 GHz ~ 25 GHz
Input Power	120 Vac, 60 Hz	Detector Function	Peak (PK) Average (AV)
Environmental Conditions	25 deg. C, 65 % RH	Tested By	Thomas Wei

### Horizontal

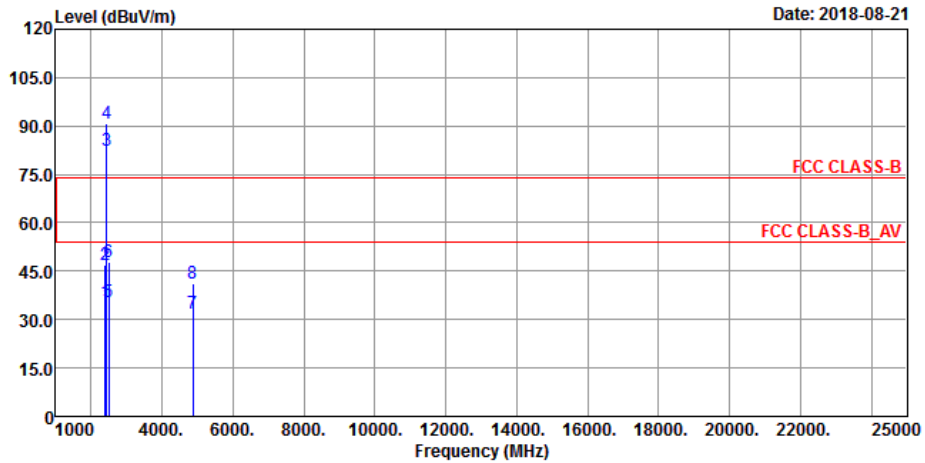

### Vertical

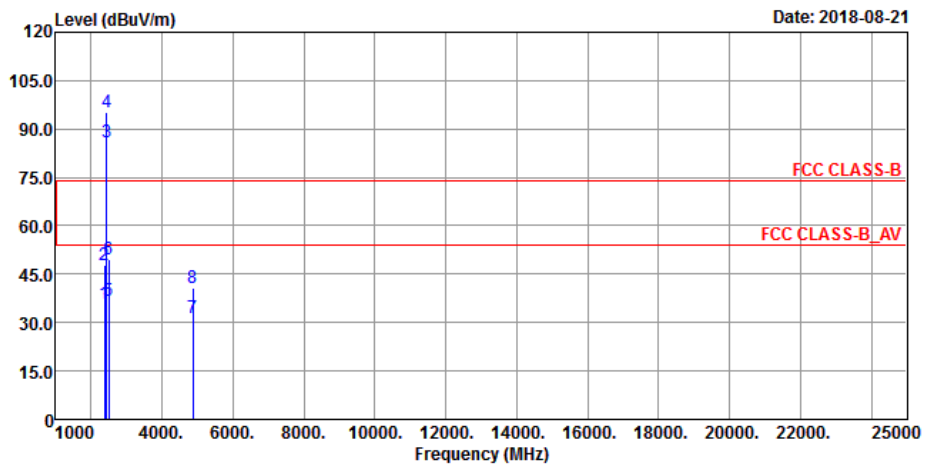

Antenna Polarity & Test Distance: Horizontal at 3 m										
Frequency (MHz)	Emission Level (dBuV/m)	Read Level (dBuV)	Limit (dBuV/m)	Margin (dB)	Antenna Factor (dB/m)	Cable Loss (dB)	Preamp Factor (dB)	Antenna Height (cm)	Table Angle (Degree)	Remark
2388.33	35.23	41.22	54	-18.77	27.16	4.35	37.5	149	135	Average
2388.33	46.81	52.8	74	-27.19	27.16	4.35	37.5	149	135	Peak
2437	82.49	88.17			27.38	4.4	37.46	149	135	Average
2437	90.83	96.51			27.38	4.4	37.46	149	135	Peak
2490	35.62	40.9	54	-18.38	27.61	4.43	37.32	149	135	Average
2490	48.04	53.32	74	-25.96	27.61	4.43	37.32	149	135	Peak
4874	31.74	47.2	54	-22.26	31.25	6.15	52.86	143	179	Average
4874	41.05	56.51	74	-32.95	31.25	6.15	52.86	143	179	Peak

Antenna Polarity & Test Distance: Vertical at 3 m										
Frequency (MHz)	Emission Level (dBuV/m)	Read Level (dBuV)	Limit (dBuV/m)	Margin (dB)	Antenna Factor (dB/m)	Cable Loss (dB)	Preamp Factor (dB)	Antenna Height (cm)	Table Angle (Degree)	Remark
2377.8	35.71	41.78	54	-18.29	27.08	4.35	37.5	171	83	Average
2377.8	48.02	54.09	74	-25.98	27.08	4.35	37.5	171	83	Peak
2437	85.73	91.41			27.38	4.4	37.46	171	83	Average
2437	95.06	100.74			27.38	4.4	37.46	171	83	Peak
2487.81	36.94	42.22	54	-17.06	27.61	4.43	37.32	171	83	Average
2487.81	49.59	54.87	74	-24.41	27.61	4.43	37.32	171	83	Peak
4874	31.26	46.72	54	-22.74	31.25	6.15	52.86	135	81	Average
4874	40.8	56.26	74	-33.2	31.25	6.15	52.86	135	81	Peak

Remarks:

- Emission Level = Read Level + Antenna Factor + Cable Loss - Preamp Factor  
Margin value = Emission level – Limit value
- 2437 MHz: Fundamental frequency.
- The other emission levels were very low against the limit.

EUT Test Condition		Measurement Detail	
Channel	Channel 11	Frequency Range	1 GHz ~ 25 GHz
Input Power	120 Vac, 60 Hz	Detector Function	Peak (PK) Average (AV)
Environmental Conditions	25 deg. C, 65 % RH	Tested By	Thomas Wei

### Horizontal

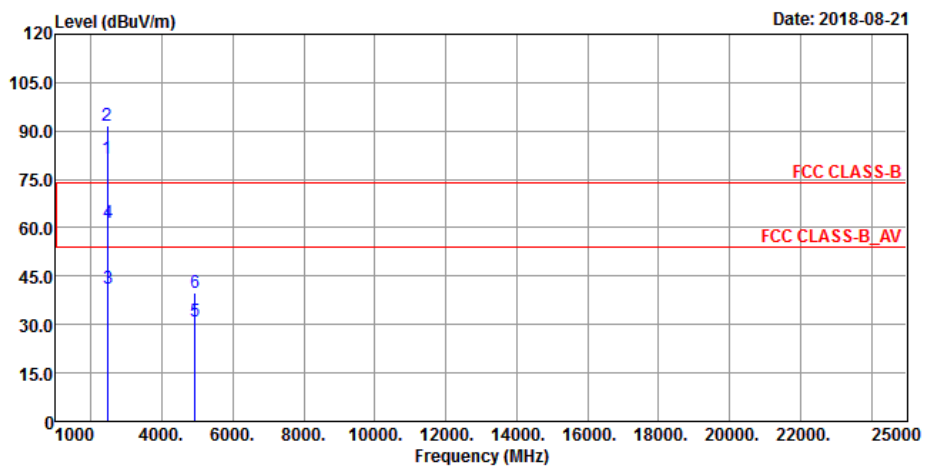

### Vertical

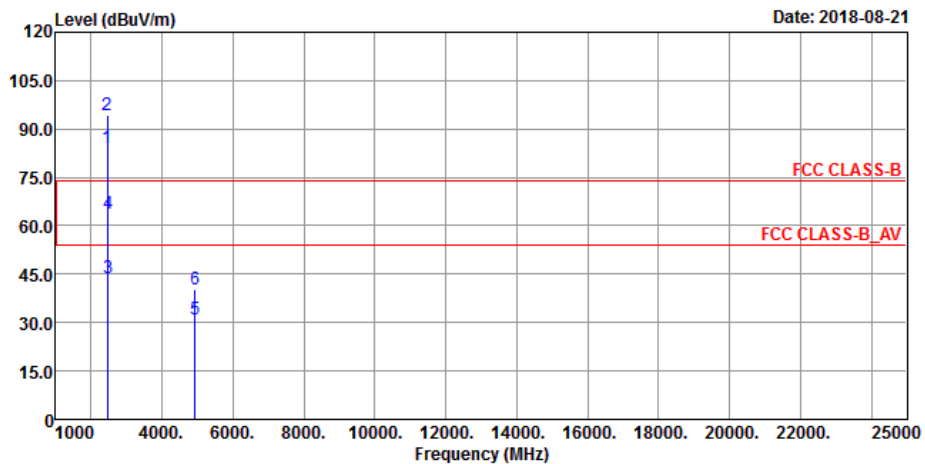

Antenna Polarity & Test Distance: Horizontal at 3 m										
Frequency (MHz)	Emission Level (dBuV/m)	Read Level (dBuV)	Limit (dBuV/m)	Margin (dB)	Antenna Factor (dB/m)	Cable Loss (dB)	Preamp Factor (dB)	Antenna Height (cm)	Table Angle (Degree)	Remark
2462	81.54	87.06			27.46	4.41	37.39	116	193	Average
2462	91.77	97.29			27.46	4.41	37.39	116	193	Peak
2483.92	41.22	46.58	54	-12.78	27.53	4.43	37.32	116	193	Average
2483.92	61.37	66.73	74	-12.63	27.53	4.43	37.32	116	193	Peak
4924	30.93	46.29	54	-23.07	31.34	6.19	52.89	114	327	Average
4924	39.79	55.15	74	-34.21	31.34	6.19	52.89	114	327	Peak
Antenna Polarity & Test Distance: Vertical at 3 m										
Frequency (MHz)	Emission Level (dBuV/m)	Read Level (dBuV)	Limit (dBuV/m)	Margin (dB)	Antenna Factor (dB/m)	Cable Loss (dB)	Preamp Factor (dB)	Antenna Height (cm)	Table Angle (Degree)	Remark
2462	83.97	89.49			27.46	4.41	37.39	151	47	Average
2462	94.49	100.01			27.46	4.41	37.39	151	47	Peak
2483.52	43.71	49.07	54	-10.29	27.53	4.43	37.32	151	47	Average
2483.52	63.68	69.04	74	-10.32	27.53	4.43	37.32	151	47	Peak
4924	30.82	46.18	54	-23.18	31.34	6.19	52.89	169	77	Average
4924	40.45	55.81	74	-33.55	31.34	6.19	52.89	169	77	Peak

Remarks:

1. Emission Level = Read Level + Antenna Factor + Cable Loss - Preamp Factor  
Margin value = Emission level – Limit value
2. 2462 MHz: Fundamental frequency.
3. The other emission levels were very low against the limit.

EUT Test Condition		Measurement Detail	
Channel	Channel 12	Frequency Range	1 GHz ~ 25 GHz
Input Power	120 Vac, 60 Hz	Detector Function	Peak (PK) Average (AV)
Environmental Conditions	25 deg. C, 65 % RH	Tested By	Thomas Wei

### Horizontal

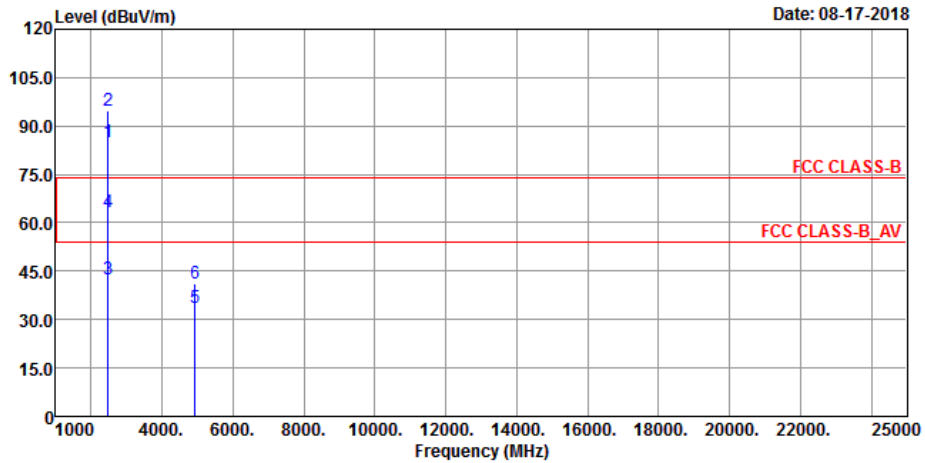

### Vertical

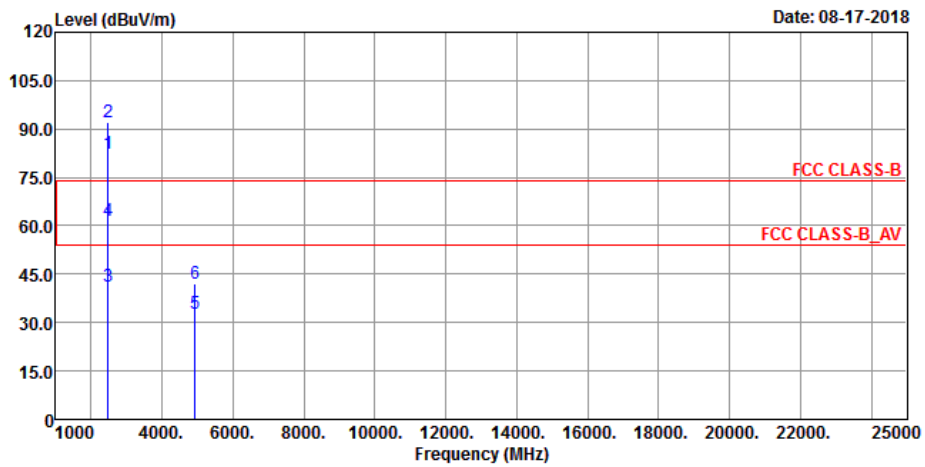

Antenna Polarity & Test Distance: Horizontal at 3 m										
Frequency (MHz)	Emission Level (dBUV/m)	Read Level (dBUV)	Limit (dBUV/m)	Margin (dB)	Antenna Factor (dB/m)	Cable Loss (dB)	Preamp Factor (dB)	Antenna Height (cm)	Table Angle (Degree)	Remark
2467	84.88	90.32			27.46	4.42	37.32	160	190	Average
2467	94.81	100.25			27.46	4.42	37.32	160	190	Peak
2483.6	42.63	47.99	54	-11.37	27.53	4.43	37.32	160	190	Average
2483.6	63.32	68.68	74	-10.68	27.53	4.43	37.32	160	190	Peak
4934	33.54	48.2	54	-20.46	31.34	6.89	52.89	167	225	Average
4934	41.03	55.69	74	-32.97	31.34	6.89	52.89	167	225	Peak
Antenna Polarity & Test Distance: Vertical at 3 m										
Frequency (MHz)	Emission Level (dBUV/m)	Read Level (dBUV)	Limit (dBUV/m)	Margin (dB)	Antenna Factor (dB/m)	Cable Loss (dB)	Preamp Factor (dB)	Antenna Height (cm)	Table Angle (Degree)	Remark
2467	82.55	87.99			27.46	4.42	37.32	178	0	Average
2467	92.15	97.59			27.46	4.42	37.32	178	0	Peak
2483.68	41.27	46.63	54	-12.73	27.53	4.43	37.32	178	0	Average
2483.68	61.76	67.12	74	-12.24	27.53	4.43	37.32	178	0	Peak
4934	32.84	47.5	54	-21.16	31.34	6.89	52.89	160	334	Average
4934	42.07	56.73	74	-31.93	31.34	6.89	52.89	160	334	Peak

Remarks:

1. Emission Level = Read Level + Antenna Factor + Cable Loss - Preamp Factor  
Margin value = Emission level – Limit value
2. 2467 MHz: Fundamental frequency.
3. The other emission levels were very low against the limit.

EUT Test Condition		Measurement Detail	
Channel	Channel 13	Frequency Range	1 GHz ~ 25 GHz
Input Power	120 Vac, 60 Hz	Detector Function	Peak (PK) Average (AV)
Environmental Conditions	25 deg. C, 65 % RH	Tested By	Thomas Wei

### Horizontal

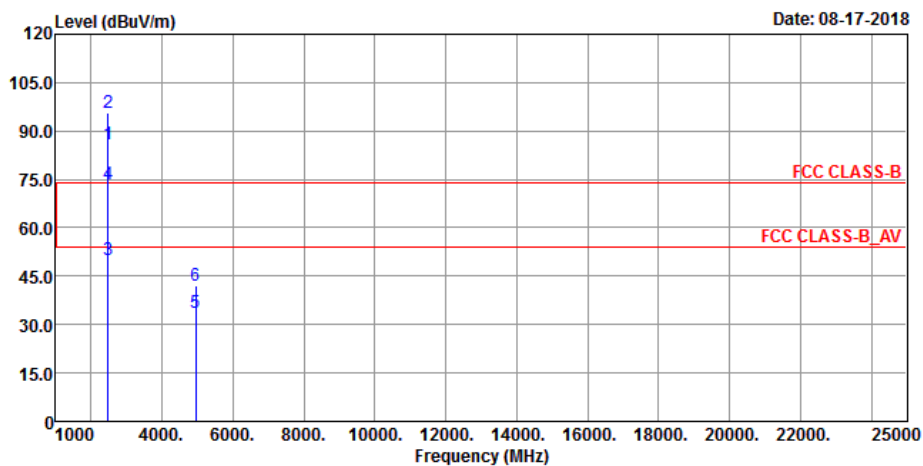

### Vertical

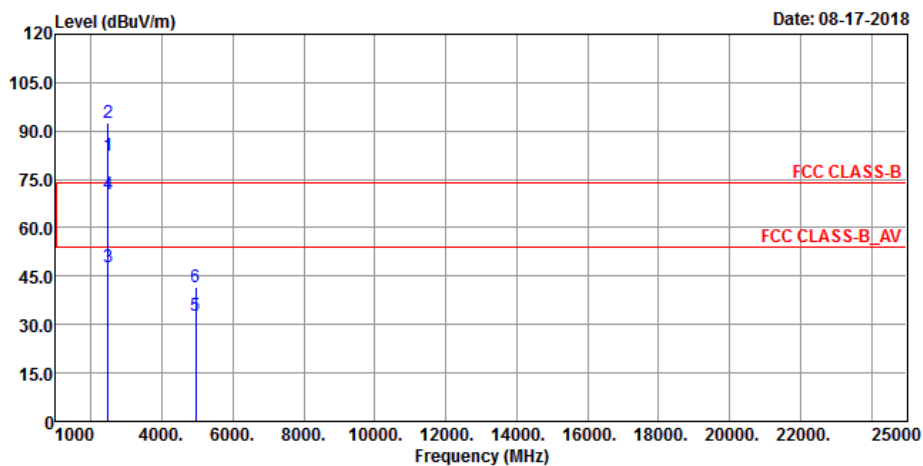

Antenna Polarity & Test Distance: Horizontal at 3 m										
Frequency (MHz)	Emission Level (dBuV/m)	Read Level (dBuV)	Limit (dBuV/m)	Margin (dB)	Antenna Factor (dB/m)	Cable Loss (dB)	Preamp Factor (dB)	Antenna Height (cm)	Table Angle (Degree)	Remark
2472	85.7	91.07			27.53	4.42	37.32	126	187	Average
2472	95.74	101.11			27.53	4.42	37.32	126	187	Peak
2483.6	49.93	55.29	54	-4.07	27.53	4.43	37.32	126	187	Average
<b>2483.6</b>	<b>73.56</b>	<b>78.92</b>	<b>74</b>	<b>-0.44</b>	<b>27.53</b>	<b>4.43</b>	<b>37.32</b>	<b>126</b>	<b>187</b>	<b>Peak</b>
4944	33.75	48.41	54	-20.25	31.37	6.89	52.92	204	155	Average
4944	42.26	56.92	74	-31.74	31.37	6.89	52.92	204	155	Peak
Antenna Polarity & Test Distance: Vertical at 3 m										
Frequency (MHz)	Emission Level (dBuV/m)	Read Level (dBuV)	Limit (dBuV/m)	Margin (dB)	Antenna Factor (dB/m)	Cable Loss (dB)	Preamp Factor (dB)	Antenna Height (cm)	Table Angle (Degree)	Remark
2472	82.45	87.82			27.53	4.42	37.32	173	0	Average
2472	92.33	97.7			27.53	4.42	37.32	173	0	Peak
2483.56	47.67	53.03	54	-6.33	27.53	4.43	37.32	173	0	Average
2483.56	70.49	75.85	74	-3.51	27.53	4.43	37.32	173	0	Peak
4944	32.93	47.59	54	-21.07	31.37	6.89	52.92	139	124	Average
4944	41.49	56.15	74	-32.51	31.37	6.89	52.92	139	124	Peak

Remarks:

1. Emission Level = Read Level + Antenna Factor + Cable Loss - Preamp Factor  
Margin value = Emission level – Limit value
2. 2472 MHz: Fundamental frequency.
3. The other emission levels were very low against the limit.



**Mode B**  
**802.11b**

EUT Test Condition		Measurement Detail	
Channel	Channel 1	Frequency Range	1 GHz ~ 25 GHz
Input Power	120 Vac, 60 Hz	Detector Function	Peak (PK) Average (AV)
Environmental Conditions	25 deg. C, 65 % RH	Tested By	Thomas Wei

**Horizontal**

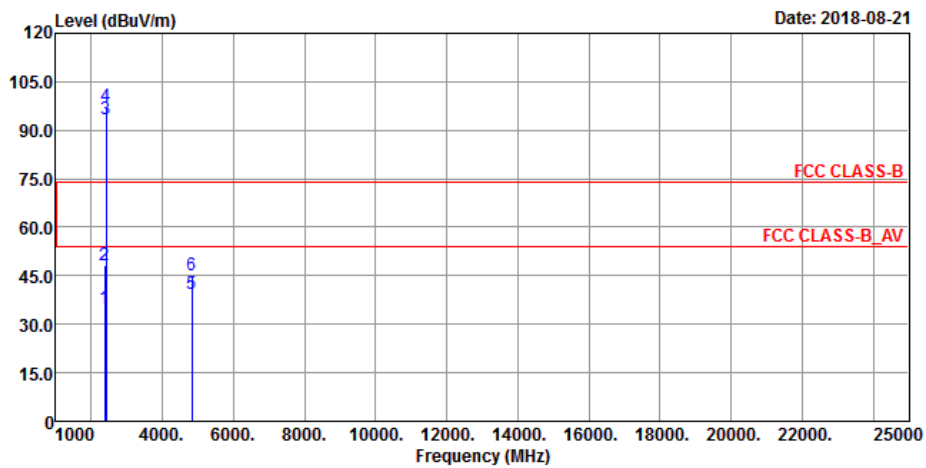

**Vertical**

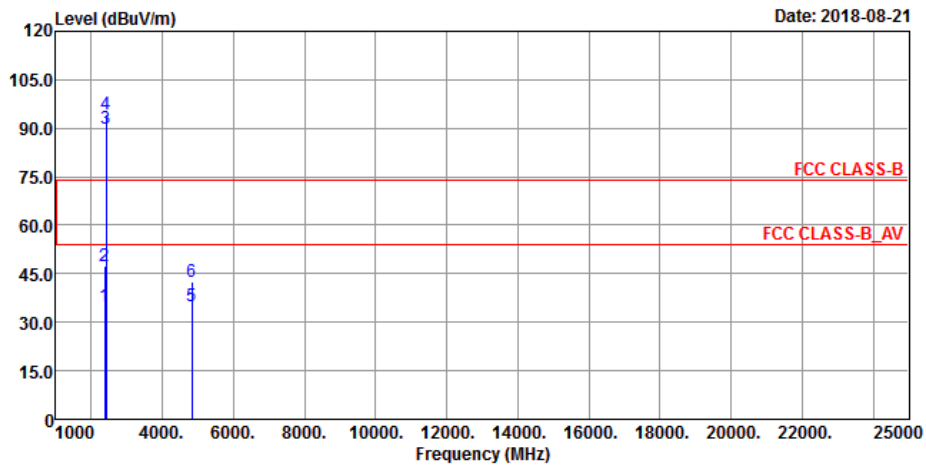

Antenna Polarity & Test Distance: Horizontal at 3 m										
Frequency (MHz)	Emission Level (dBuV/m)	Read Level (dBuV)	Limit (dBuV/m)	Margin (dB)	Antenna Factor (dB/m)	Cable Loss (dB)	Preamp Factor (dB)	Antenna Height (cm)	Table Angle (Degree)	Remark
2381.66	35.19	41.26	54	-18.81	27.08	4.35	37.5	159	233	Average
2381.66	48.06	54.13	74	-25.94	27.08	4.35	37.5	159	233	Peak
2412	93.28	99.19			27.23	4.38	37.52	159	233	Average
2412	97.28	103.19			27.23	4.38	37.52	159	233	Peak
4824	39.27	54.89	54	-14.73	31.17	6.1	52.89	122	311	Average
4824	45.13	60.75	74	-28.87	31.17	6.1	52.89	122	311	Peak
Antenna Polarity & Test Distance: Vertical at 3 m										
Frequency (MHz)	Emission Level (dBuV/m)	Read Level (dBuV)	Limit (dBuV/m)	Margin (dB)	Antenna Factor (dB/m)	Cable Loss (dB)	Preamp Factor (dB)	Antenna Height (cm)	Table Angle (Degree)	Remark
2371.8	35.18	41.17	54	-18.82	27.16	4.35	37.5	161	170	Average
2371.8	47.26	69.71	74	-26.74	27.08	4.34	53.87	161	170	Peak
2412	90.08	95.99			27.23	4.38	37.52	161	170	Average
2412	94.24	100.15			27.23	4.38	37.52	161	170	Peak
4824	35.16	50.78	54	-18.84	31.17	6.1	52.89	138	79	Average
4824	42.31	57.93	74	-31.69	31.17	6.1	52.89	138	79	Peak

Remarks:

1. Emission Level = Read Level + Antenna Factor + Cable Loss - Preamp Factor  
Margin value = Emission level – Limit value
2. 2412 MHz: Fundamental frequency.
3. The other emission levels were very low against the limit.

EUT Test Condition		Measurement Detail	
Channel	Channel 6	Frequency Range	1 GHz ~ 25 GHz
Input Power	120 Vac, 60 Hz	Detector Function	Peak (PK) Average (AV)
Environmental Conditions	25 deg. C, 65 % RH	Tested By	Thomas Wei

### Horizontal

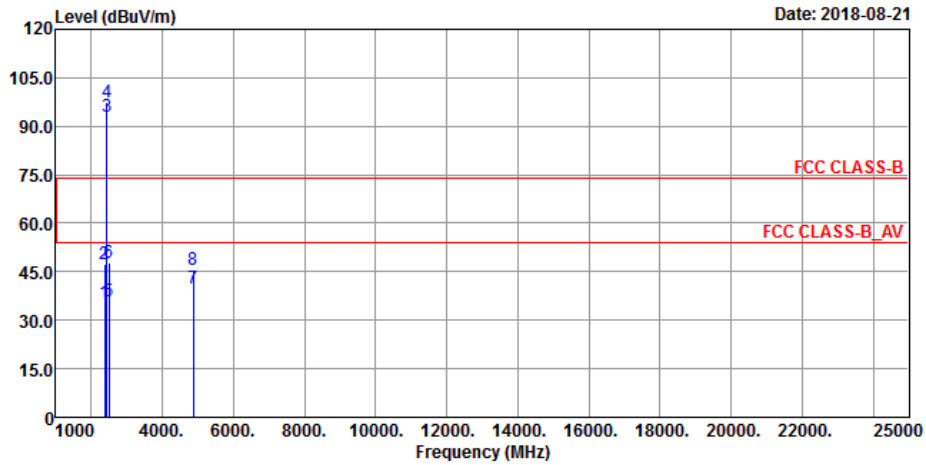

### Vertical

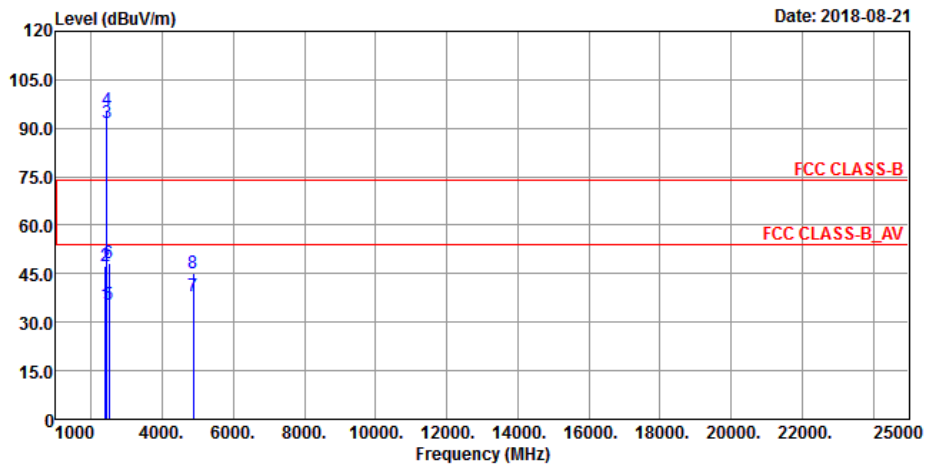

Antenna Polarity & Test Distance: Horizontal at 3 m										
Frequency (MHz)	Emission Level (dBuV/m)	Read Level (dBuV)	Limit (dBuV/m)	Margin (dB)	Antenna Factor (dB/m)	Cable Loss (dB)	Preamp Factor (dB)	Antenna Height (cm)	Table Angle (Degree)	Remark
2380.01	35.33	41.4	54	-18.67	27.08	4.35	37.5	176	126	Average
2380.01	47.31	53.38	74	-26.69	27.08	4.35	37.5	176	126	Peak
2437	92.93	98.61			27.38	4.4	37.46	176	126	Average
2437	97.3	102.98			27.38	4.4	37.46	176	126	Peak
2494.86	35.68	40.89	54	-18.32	27.61	4.43	37.25	176	126	Average
2494.86	47.83	53.04	74	-26.17	27.61	4.43	37.25	176	126	Peak
4874	39.98	55.44	54	-14.02	31.25	6.15	52.86	161	227	Average
4874	45.43	60.89	74	-28.57	31.25	6.15	52.86	161	227	Peak

Antenna Polarity & Test Distance: Vertical at 3 m										
Frequency (MHz)	Emission Level (dBuV/m)	Read Level (dBuV)	Limit (dBuV/m)	Margin (dB)	Antenna Factor (dB/m)	Cable Loss (dB)	Preamp Factor (dB)	Antenna Height (cm)	Table Angle (Degree)	Remark
2387.66	35.3	41.37	54	-18.7	27.08	4.35	37.5	142	241	Average
2387.66	47.17	53.24	74	-26.83	27.08	4.35	37.5	142	241	Peak
2437	91.83	97.51			27.38	4.4	37.46	142	241	Average
2437	95.72	101.4			27.38	4.4	37.46	142	241	Peak
2493.04	35.49	40.77	54	-18.51	27.61	4.43	37.32	142	241	Average
2493.04	48.4	53.68	74	-25.6	27.61	4.43	37.32	142	241	Peak
4874	38.26	53.01	54	-15.74	31.25	6.86	52.86	164	55	Average
4874	45.09	59.84	74	-28.91	31.25	6.86	52.86	164	55	Peak

Remarks:

- Emission Level = Read Level + Antenna Factor + Cable Loss - Preamp Factor  
Margin value = Emission level – Limit value
- 2437 MHz: Fundamental frequency.
- The other emission levels were very low against the limit.

EUT Test Condition		Measurement Detail	
Channel	Channel 11	Frequency Range	1 GHz ~ 25 GHz
Input Power	120 Vac, 60 Hz	Detector Function	Peak (PK) Average (AV)
Environmental Conditions	25 deg. C, 65 % RH	Tested By	Thomas Wei

### Horizontal

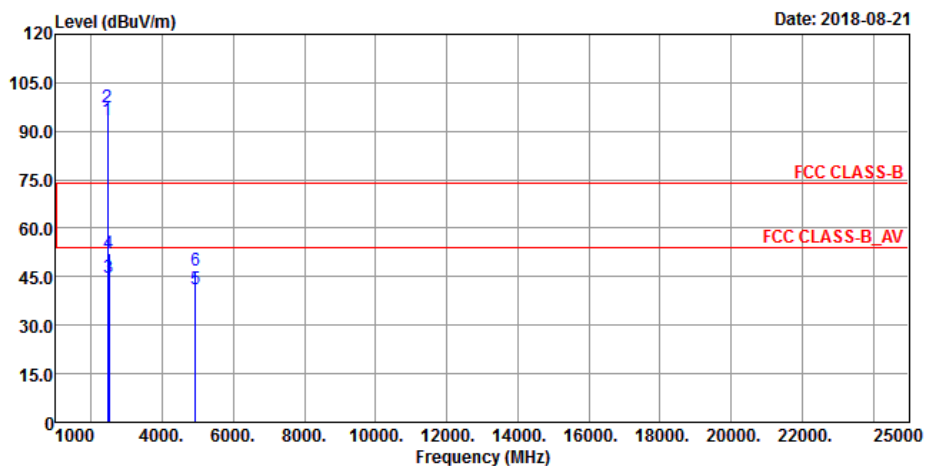

### Vertical

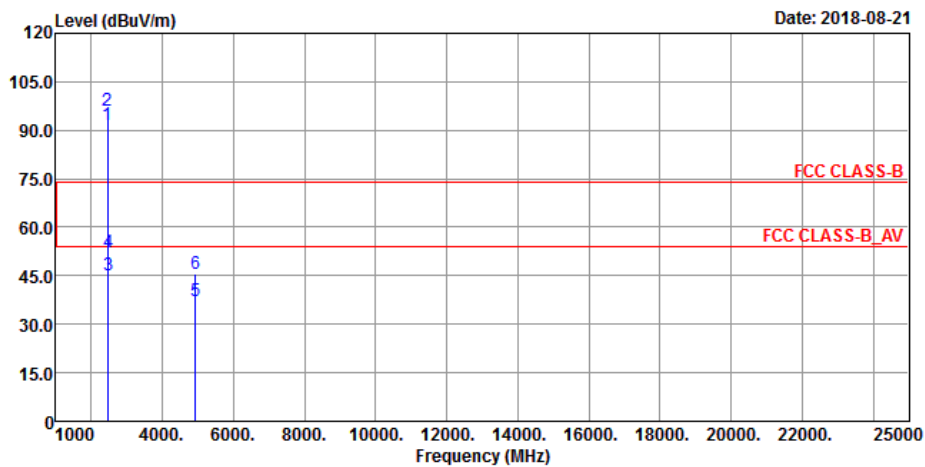

Antenna Polarity & Test Distance: Horizontal at 3 m										
Frequency (MHz)	Emission Level (dBuV/m)	Read Level (dBuV)	Limit (dBuV/m)	Margin (dB)	Antenna Factor (dB/m)	Cable Loss (dB)	Preamp Factor (dB)	Antenna Height (cm)	Table Angle (Degree)	Remark
2462	93.37	98.89			27.46	4.41	37.39	149	195	Average
2462	97.23	102.75			27.46	4.41	37.39	149	195	Peak
2488.69	44.7	50.06	54	-9.3	27.53	4.43	37.32	149	195	Average
2488.69	52.39	57.75	74	-21.61	27.53	4.43	37.32	149	195	Peak
4924	41.03	55.69	54	-12.97	31.34	6.89	52.89	147	113	Average
4924	46.82	61.48	74	-27.18	31.34	6.89	52.89	147	113	Peak
Antenna Polarity & Test Distance: Vertical at 3 m										
Frequency (MHz)	Emission Level (dBuV/m)	Read Level (dBuV)	Limit (dBuV/m)	Margin (dB)	Antenna Factor (dB/m)	Cable Loss (dB)	Preamp Factor (dB)	Antenna Height (cm)	Table Angle (Degree)	Remark
2462	91.72	97.24			27.46	4.41	37.39	137	12	Average
2462	95.88	101.4			27.46	4.41	37.39	137	12	Peak
2483.66	45.19	50.47	54	-8.81	27.61	4.43	37.32	137	12	Average
2483.66	52.38	57.74	74	-21.62	27.53	4.43	37.32	137	12	Peak
4924	36.98	51.64	54	-17.02	31.34	6.89	52.89	113	164	Average
4924	45.51	60.17	74	-28.49	31.34	6.89	52.89	113	164	Peak

Remarks:

1. Emission Level = Read Level + Antenna Factor + Cable Loss - Preamp Factor  
Margin value = Emission level – Limit value
2. 2462 MHz: Fundamental frequency.
3. The other emission levels were very low against the limit.

EUT Test Condition		Measurement Detail	
Channel	Channel 12	Frequency Range	1 GHz ~ 25 GHz
Input Power	120 Vac, 60 Hz	Detector Function	Peak (PK) Average (AV)
Environmental Conditions	25 deg. C, 65 % RH	Tested By	Thomas Wei

### Horizontal

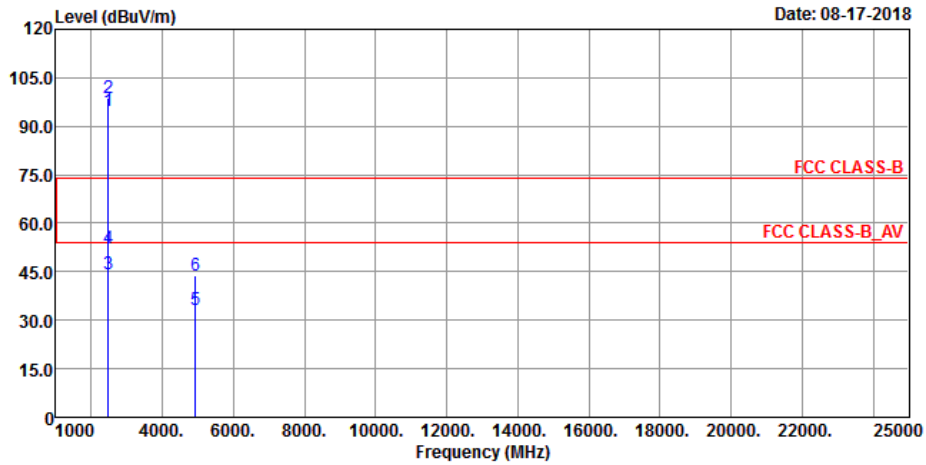

### Vertical

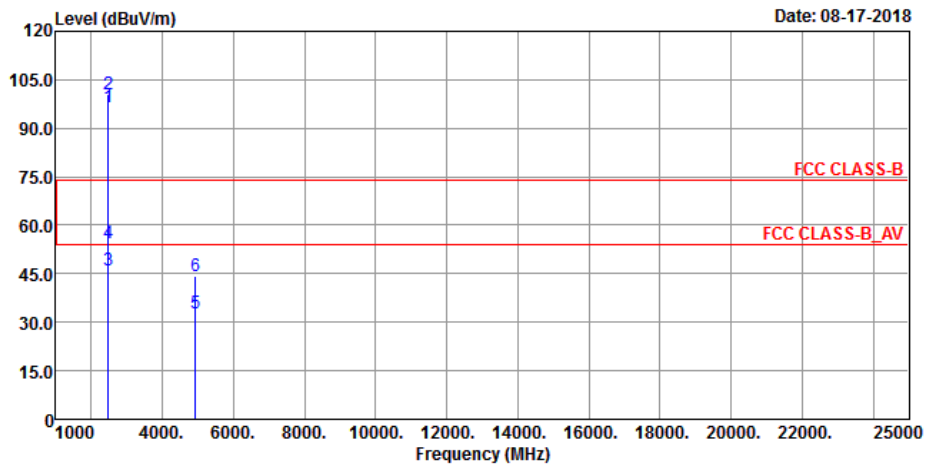

Antenna Polarity & Test Distance: Horizontal at 3 m										
Frequency (MHz)	Emission Level (dBuV/m)	Read Level (dBuV)	Limit (dBuV/m)	Margin (dB)	Antenna Factor (dB/m)	Cable Loss (dB)	Preamp Factor (dB)	Antenna Height (cm)	Table Angle (Degree)	Remark
2467	94.67	100.11			27.46	4.42	37.32	146	165	Average
2467	98.71	104.15			27.46	4.42	37.32	146	165	Peak
2483.52	44.14	49.5	54	-9.86	27.53	4.43	37.32	146	165	Average
2483.52	52.22	57.58	74	-21.78	27.53	4.43	37.32	146	165	Peak
4934	33.18	47.84	54	-20.82	31.34	6.89	52.89	118	162	Average
4934	43.91	58.57	74	-30.09	31.34	6.89	52.89	118	162	Peak
Antenna Polarity & Test Distance: Vertical at 3 m										
Frequency (MHz)	Emission Level (dBuV/m)	Read Level (dBuV)	Limit (dBuV/m)	Margin (dB)	Antenna Factor (dB/m)	Cable Loss (dB)	Preamp Factor (dB)	Antenna Height (cm)	Table Angle (Degree)	Remark
2467	96.55	101.99			27.46	4.42	37.32	132	183	Average
2467	100.6	106.04			27.46	4.42	37.32	132	183	Peak
2483.52	45.87	51.23	54	-8.13	27.53	4.43	37.32	132	183	Average
2483.52	54.41	59.77	74	-19.59	27.53	4.43	37.32	132	183	Peak
4934	32.9	47.56	54	-21.1	31.34	6.89	52.89	122	251	Average
4934	44.36	59.02	74	-29.64	31.34	6.89	52.89	122	251	Peak

Remarks:

1. Emission Level = Read Level + Antenna Factor + Cable Loss - Preamp Factor  
Margin value = Emission level – Limit value
2. 2467 MHz: Fundamental frequency.
3. The other emission levels were very low against the limit.



EUT Test Condition		Measurement Detail	
Channel	Channel 13	Frequency Range	1 GHz ~ 25 GHz
Input Power	120 Vac, 60 Hz	Detector Function	Peak (PK) Average (AV)
Environmental Conditions	25 deg. C, 65 % RH	Tested By	Thomas Wei

### Horizontal

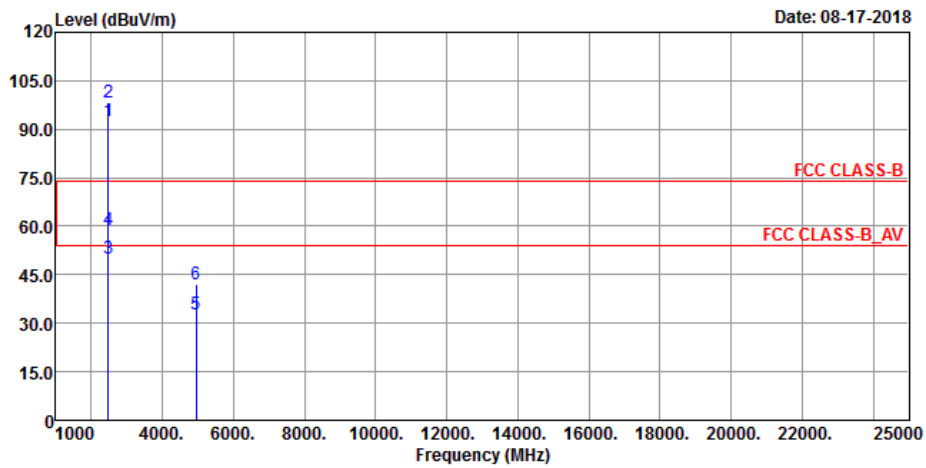

### Vertical

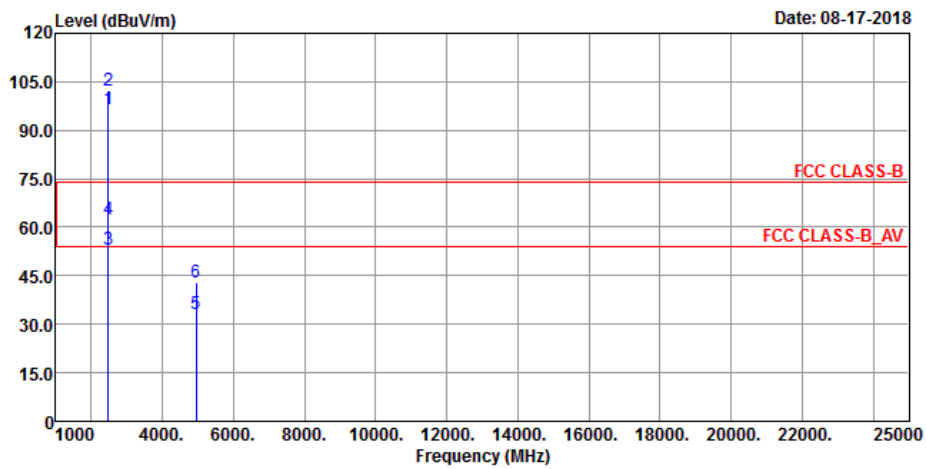

Antenna Polarity & Test Distance: Horizontal at 3 m										
Frequency (MHz)	Emission Level (dBuV/m)	Read Level (dBuV)	Limit (dBuV/m)	Margin (dB)	Antenna Factor (dB/m)	Cable Loss (dB)	Preamp Factor (dB)	Antenna Height (cm)	Table Angle (Degree)	Remark
2472	92.65	98.02			27.53	4.42	37.32	143	152	Average
2472	98.43	103.8			27.53	4.42	37.32	143	152	Peak
2483.52	49.89	55.25	54	-4.11	27.53	4.43	37.32	143	152	Average
2483.52	58.79	64.15	74	-15.21	27.53	4.43	37.32	143	152	Peak
4944	32.83	47.49	54	-21.17	31.37	6.89	52.92	141	203	Average
4944	42.06	56.72	74	-31.94	31.37	6.89	52.92	141	203	Peak
Antenna Polarity & Test Distance: Vertical at 3 m										
Frequency (MHz)	Emission Level (dBuV/m)	Read Level (dBuV)	Limit (dBuV/m)	Margin (dB)	Antenna Factor (dB/m)	Cable Loss (dB)	Preamp Factor (dB)	Antenna Height (cm)	Table Angle (Degree)	Remark
2472	96.48	101.85			27.53	4.42	37.32	117	170	Average
2472	102.41	107.78			27.53	4.42	37.32	117	170	Peak
2483.52	53.16	58.52	54	-0.84	27.53	4.43	37.32	117	170	Average
2483.52	62.43	67.79	74	-11.57	27.53	4.43	37.32	117	170	Peak
4944	33.06	47.72	54	-20.94	31.37	6.89	52.92	152	216	Average
4944	43.05	57.71	74	-30.95	31.37	6.89	52.92	152	216	Peak

Remarks:

1. Emission Level = Read Level + Antenna Factor + Cable Loss - Preamp Factor  
Margin value = Emission level – Limit value
2. 2472 MHz: Fundamental frequency.
3. The other emission levels were very low against the limit.

802.11g

EUT Test Condition		Measurement Detail	
Channel	Channel 1	Frequency Range	1 GHz ~ 25 GHz
Input Power	120 Vac, 60 Hz	Detector Function	Peak (PK) Average (AV)
Environmental Conditions	25 deg. C, 65 % RH	Tested By	Thomas Wei

Horizontal

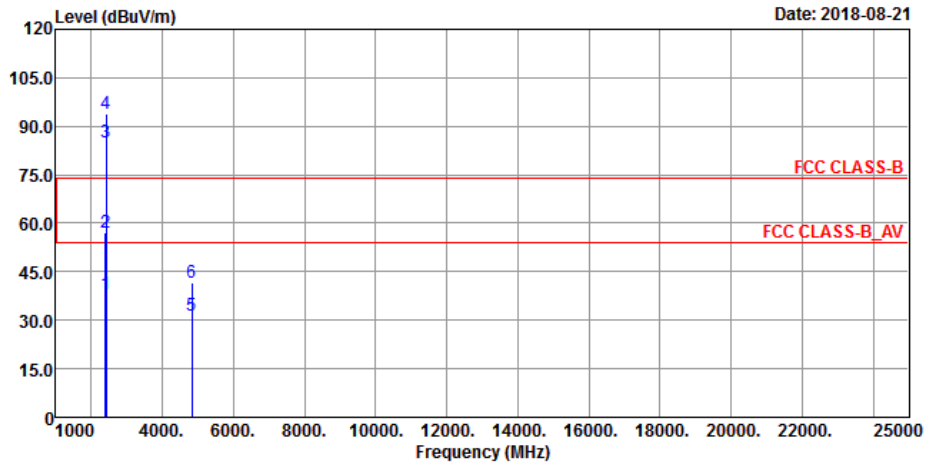

Vertical

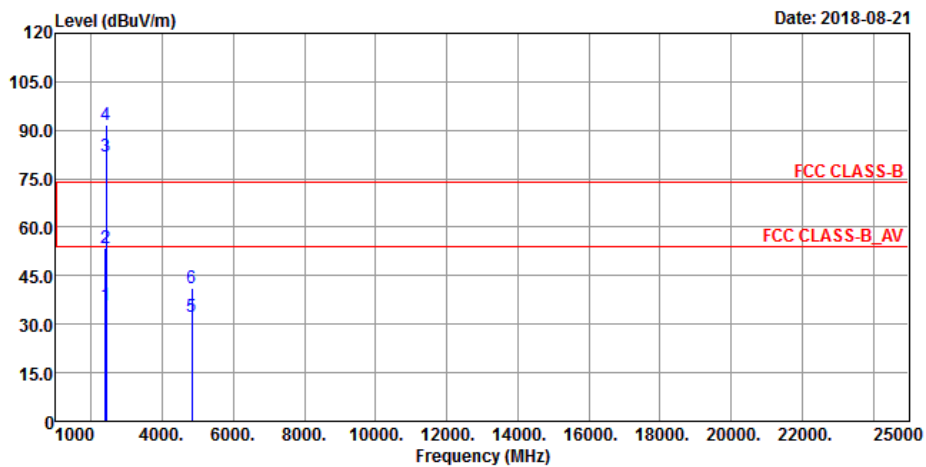

Antenna Polarity & Test Distance: Horizontal at 3 m										
Frequency (MHz)	Emission Level (dBuV/m)	Read Level (dBuV)	Limit (dBuV/m)	Margin (dB)	Antenna Factor (dB/m)	Cable Loss (dB)	Preamp Factor (dB)	Antenna Height (cm)	Table Angle (Degree)	Remark
2389.94	37.86	43.86	54	-16.14	27.16	4.36	37.52	152	210	Average
2389.94	57.15	63.15	74	-16.85	27.16	4.36	37.52	152	210	Peak
2412	84.82	90.73			27.23	4.38	37.52	152	210	Average
2412	94	99.91			27.23	4.38	37.52	152	210	Peak
4824	31.47	46.38	54	-22.53	31.17	6.81	52.89	149	122	Average
4824	41.64	56.55	74	-32.36	31.17	6.81	52.89	149	122	Peak
Antenna Polarity & Test Distance: Vertical at 3 m										
Frequency (MHz)	Emission Level (dBuV/m)	Read Level (dBuV)	Limit (dBuV/m)	Margin (dB)	Antenna Factor (dB/m)	Cable Loss (dB)	Preamp Factor (dB)	Antenna Height (cm)	Table Angle (Degree)	Remark
2389.94	35.98	41.98	54	-18.02	27.16	4.36	37.52	170	167	Average
2389.94	53.71	59.71	74	-20.29	27.16	4.36	37.52	170	167	Peak
2412	81.78	87.69			27.23	4.38	37.52	170	167	Average
2412	91.67	97.58			27.23	4.38	37.52	170	167	Peak
4824	32.12	47.03	54	-21.88	31.17	6.81	52.89	114	250	Average
4824	41.28	56.19	74	-32.72	31.17	6.81	52.89	114	250	Peak

Remarks:

1. Emission Level = Read Level + Antenna Factor + Cable Loss - Preamp Factor  
Margin value = Emission level – Limit value
2. 2412 MHz: Fundamental frequency.
3. The other emission levels were very low against the limit.

EUT Test Condition		Measurement Detail	
Channel	Channel 6	Frequency Range	1 GHz ~ 25 GHz
Input Power	120 Vac, 60 Hz	Detector Function	Peak (PK) Average (AV)
Environmental Conditions	25 deg. C, 65 % RH	Tested By	Thomas Wei

### Horizontal

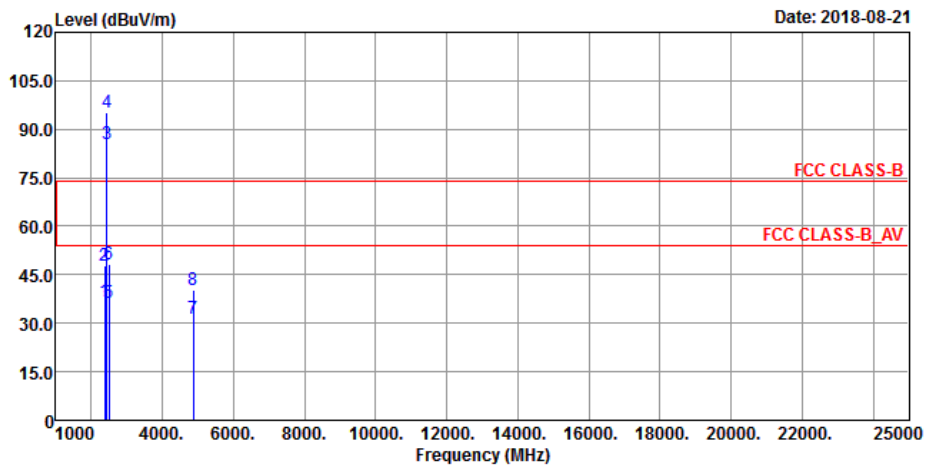

### Vertical

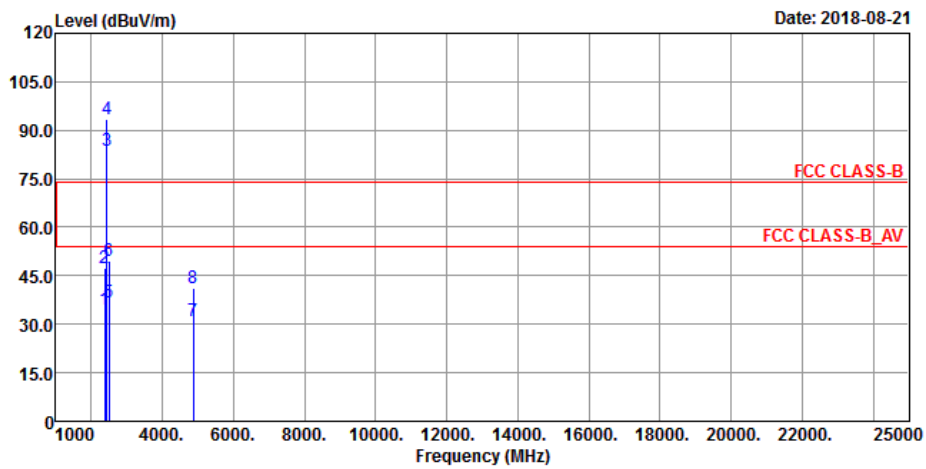

**Antenna Polarity & Test Distance: Horizontal at 3 m**

Frequency (MHz)	Emission Level (dBuV/m)	Read Level (dBuV)	Limit (dBuV/m)	Margin (dB)	Antenna Factor (dB/m)	Cable Loss (dB)	Preamp Factor (dB)	Antenna Height (cm)	Table Angle (Degree)	Remark
2371.08	36.58	42.65	54	-17.42	27.08	4.35	37.5	157	193	Average
2371.08	47.79	53.86	74	-26.21	27.08	4.35	37.5	157	193	Peak
2437	85.49	91.17			27.38	4.4	37.46	157	193	Average
2437	95.25	100.93			27.38	4.4	37.46	157	193	Peak
2485.33	36.22	41.5	54	-17.78	27.61	4.43	37.32	157	193	Average
2485.33	48.33	53.61	74	-25.67	27.61	4.43	37.32	157	193	Peak
4874	31.33	46.79	54	-22.67	31.25	6.15	52.86	108	49	Average
4874	40.38	55.84	74	-33.62	31.25	6.15	52.86	108	49	Peak

**Antenna Polarity & Test Distance: Vertical at 3 m**

Frequency (MHz)	Emission Level (dBuV/m)	Read Level (dBuV)	Limit (dBuV/m)	Margin (dB)	Antenna Factor (dB/m)	Cable Loss (dB)	Preamp Factor (dB)	Antenna Height (cm)	Table Angle (Degree)	Remark
2376.51	34.71	40.78	54	-19.29	27.08	4.35	37.5	156	10	Average
2376.51	47.28	53.35	74	-26.72	27.08	4.35	37.5	156	10	Peak
2437	83.64	89.32			27.38	4.4	37.46	156	10	Average
2437	93.47	99.15			27.38	4.4	37.46	156	10	Peak
2492.13	36.59	41.87	54	-17.41	27.61	4.43	37.32	156	10	Average
2492.13	49.79	55.07	74	-24.21	27.61	4.43	37.32	156	10	Peak
4874	31.03	46.49	54	-22.97	31.25	6.15	52.86	141	214	Average
4874	41.07	56.53	74	-32.93	31.25	6.15	52.86	141	214	Peak

Remarks:

- Emission Level = Read Level + Antenna Factor + Cable Loss - Preamp Factor  
Margin value = Emission level – Limit value
- 2437 MHz: Fundamental frequency.
- The other emission levels were very low against the limit.

EUT Test Condition		Measurement Detail	
Channel	Channel 11	Frequency Range	1 GHz ~ 25 GHz
Input Power	120 Vac, 60 Hz	Detector Function	Peak (PK) Average (AV)
Environmental Conditions	25 deg. C, 65 % RH	Tested By	Thomas Wei

### Horizontal

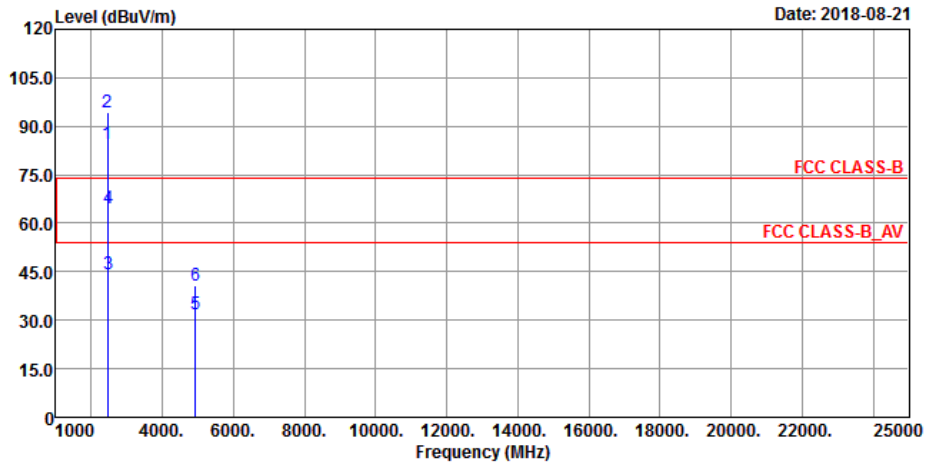

### Vertical

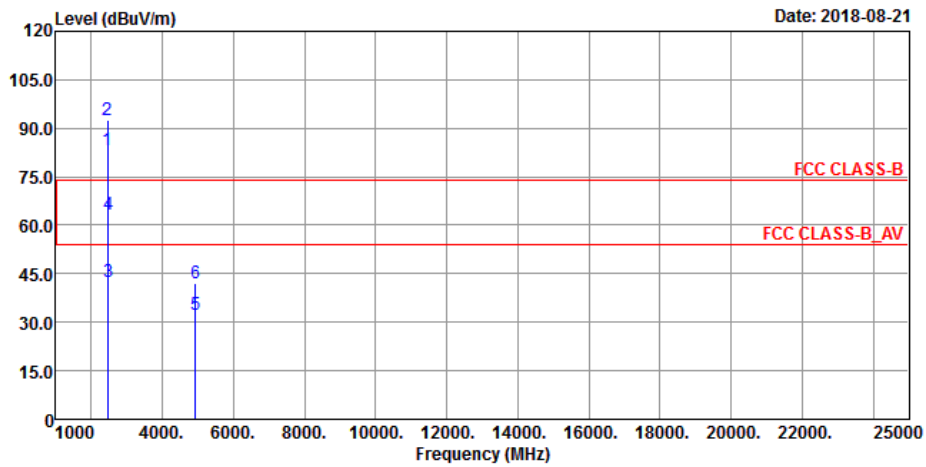

Antenna Polarity & Test Distance: Horizontal at 3 m										
Frequency (MHz)	Emission Level (dBuV/m)	Read Level (dBuV)	Limit (dBuV/m)	Margin (dB)	Antenna Factor (dB/m)	Cable Loss (dB)	Preamp Factor (dB)	Antenna Height (cm)	Table Angle (Degree)	Remark
2462	84.72	90.24			27.46	4.41	37.39	129	198	Average
2462	94.33	99.85			27.46	4.41	37.39	129	198	Peak
2483.52	44.36	49.72	54	-9.64	27.53	4.43	37.32	129	198	Average
2483.52	64.58	69.94	74	-9.42	27.53	4.43	37.32	129	198	Peak
4924	31.8	47.16	54	-22.2	31.34	6.19	52.89	184	339	Average
4924	40.91	56.27	74	-33.09	31.34	6.19	52.89	184	339	Peak
Antenna Polarity & Test Distance: Vertical at 3 m										
Frequency (MHz)	Emission Level (dBuV/m)	Read Level (dBuV)	Limit (dBuV/m)	Margin (dB)	Antenna Factor (dB/m)	Cable Loss (dB)	Preamp Factor (dB)	Antenna Height (cm)	Table Angle (Degree)	Remark
2462	83.36	88.88			27.46	4.41	37.39	150	241	Average
2462	92.39	97.91			27.46	4.41	37.39	150	241	Peak
2483.77	42.39	47.75	54	-11.61	27.53	4.43	37.32	150	241	Average
2483.77	63.17	68.53	74	-10.83	27.53	4.43	37.32	150	241	Peak
4924	32.43	47.09	54	-21.57	31.34	6.89	52.89	171	155	Average
4924	42.16	56.82	74	-31.84	31.34	6.89	52.89	171	155	Peak

Remarks:

1. Emission Level = Read Level + Antenna Factor + Cable Loss - Preamp Factor  
Margin value = Emission level – Limit value
2. 2462 MHz: Fundamental frequency.
3. The other emission levels were very low against the limit.



EUT Test Condition		Measurement Detail	
Channel	Channel 12	Frequency Range	1 GHz ~ 25 GHz
Input Power	120 Vac, 60 Hz	Detector Function	Peak (PK) Average (AV)
Environmental Conditions	25 deg. C, 65 % RH	Tested By	Thomas Wei

### Horizontal

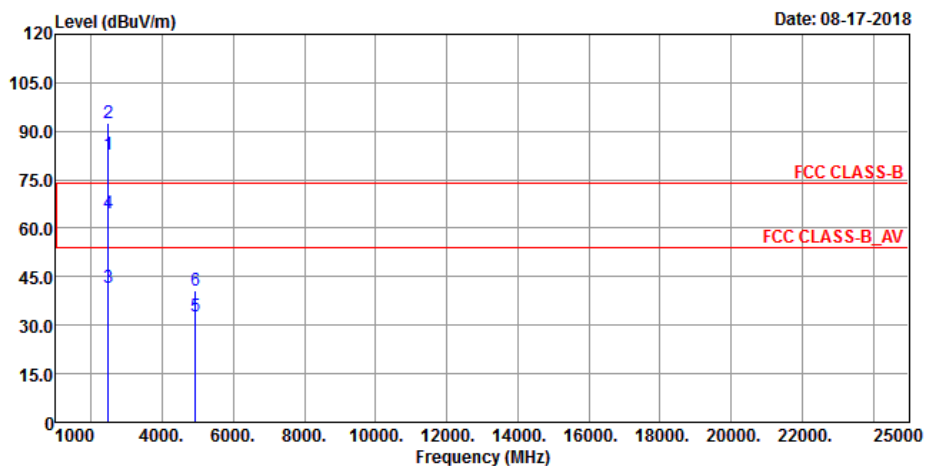

### Vertical

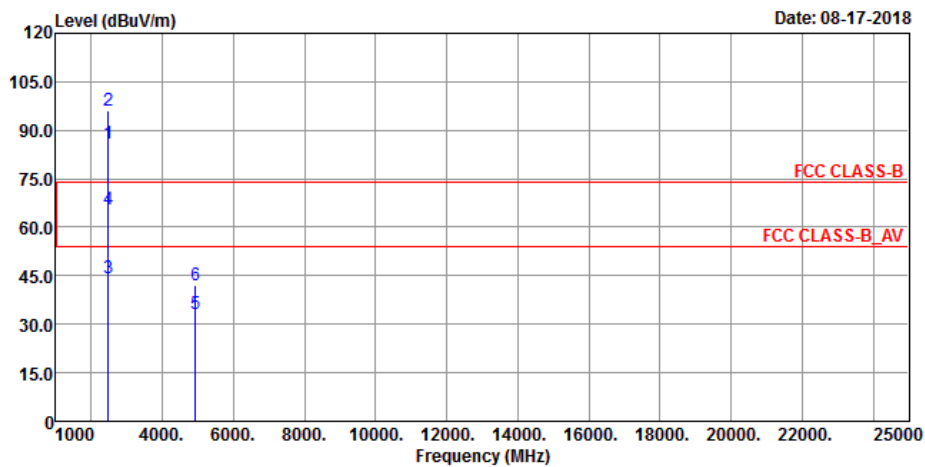

Antenna Polarity & Test Distance: Horizontal at 3 m										
Frequency (MHz)	Emission Level (dBuV/m)	Read Level (dBuV)	Limit (dBuV/m)	Margin (dB)	Antenna Factor (dB/m)	Cable Loss (dB)	Preamp Factor (dB)	Antenna Height (cm)	Table Angle (Degree)	Remark
2467	82.97	88.41			27.46	4.42	37.32	160	152	Average
2467	92.74	98.18			27.46	4.42	37.32	160	152	Peak
2483.52	41.71	47.07	54	-12.29	27.53	4.43	37.32	160	152	Average
2483.52	64.46	69.82	74	-9.54	27.53	4.43	37.32	160	152	Peak
4934	32.93	47.59	54	-21.07	31.34	6.89	52.89	156	233	Average
4934	40.94	55.6	74	-33.06	31.34	6.89	52.89	156	233	Peak
Antenna Polarity & Test Distance: Vertical at 3 m										
Frequency (MHz)	Emission Level (dBuV/m)	Read Level (dBuV)	Limit (dBuV/m)	Margin (dB)	Antenna Factor (dB/m)	Cable Loss (dB)	Preamp Factor (dB)	Antenna Height (cm)	Table Angle (Degree)	Remark
2467	86.07	91.51			27.46	4.42	37.32	118	157	Average
2467	95.97	101.41			27.46	4.42	37.32	118	157	Peak
2483.52	44.38	49.74	54	-9.62	27.53	4.43	37.32	118	157	Average
2483.52	65.5	70.86	74	-8.5	27.53	4.43	37.32	118	157	Peak
4934	33.08	47.74	54	-20.92	31.34	6.89	52.89	138	301	Average
4934	42.23	56.89	74	-31.77	31.34	6.89	52.89	138	301	Peak

Remarks:

1. Emission Level = Read Level + Antenna Factor + Cable Loss - Preamp Factor  
Margin value = Emission level – Limit value
2. 2467 MHz: Fundamental frequency.
3. The other emission levels were very low against the limit.

EUT Test Condition		Measurement Detail	
Channel	Channel 13	Frequency Range	1 GHz ~ 25 GHz
Input Power	120 Vac, 60 Hz	Detector Function	Peak (PK) Average (AV)
Environmental Conditions	25 deg. C, 65 % RH	Tested By	Thomas Wei

### Horizontal

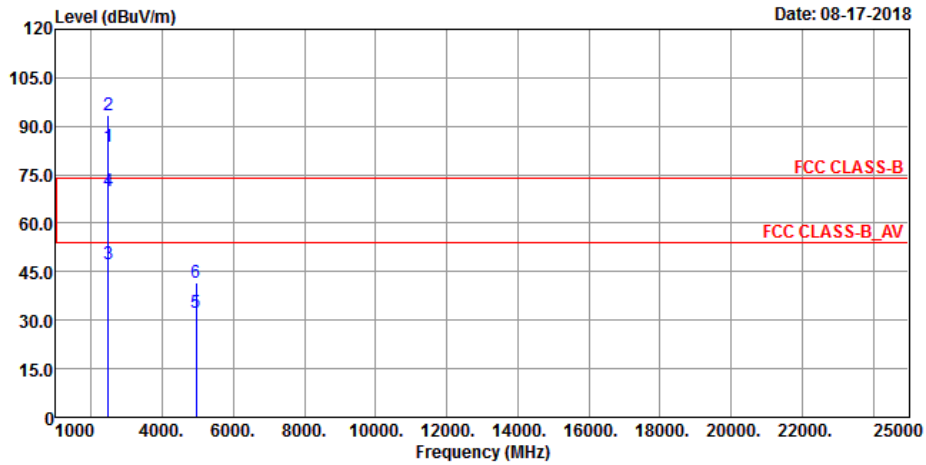

### Vertical

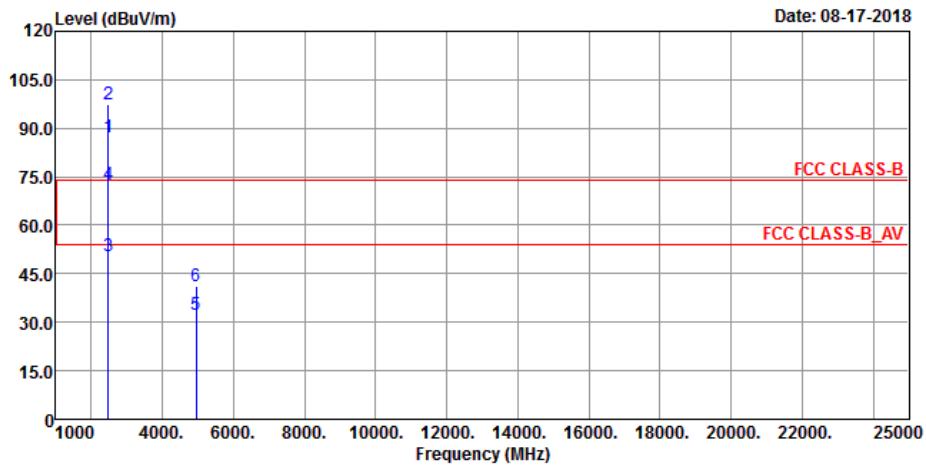

Antenna Polarity & Test Distance: Horizontal at 3 m										
Frequency (MHz)	Emission Level (dBuV/m)	Read Level (dBuV)	Limit (dBuV/m)	Margin (dB)	Antenna Factor (dB/m)	Cable Loss (dB)	Preamp Factor (dB)	Antenna Height (cm)	Table Angle (Degree)	Remark
2472	83.62	88.99			27.53	4.42	37.32	159	151	Average
2472	93.26	98.63			27.53	4.42	37.32	159	151	Peak
2483.52	47.32	52.68	54	-6.68	27.53	4.43	37.32	159	151	Average
2483.52	69.9	75.26	74	-4.1	27.53	4.43	37.32	159	151	Peak
4944	32.32	47.68	54	-21.68	31.37	6.19	52.92	151	183	Average
4944	41.62	56.98	74	-32.38	31.37	6.19	52.92	151	183	Peak
Antenna Polarity & Test Distance: Vertical at 3 m										
Frequency (MHz)	Emission Level (dBuV/m)	Read Level (dBuV)	Limit (dBuV/m)	Margin (dB)	Antenna Factor (dB/m)	Cable Loss (dB)	Preamp Factor (dB)	Antenna Height (cm)	Table Angle (Degree)	Remark
2472	87.4	92.77			27.53	4.42	37.32	117	168	Average
2472	97.31	102.68			27.53	4.42	37.32	117	168	Peak
2483.56	50.31	55.67	54	-3.69	27.53	4.43	37.32	117	168	Average
2483.56	72.67	78.03	74	-1.33	27.53	4.43	37.32	117	168	Peak
4944	32.35	47.71	54	-21.65	31.37	6.19	52.92	134	201	Average
4944	41.21	56.57	74	-32.79	31.37	6.19	52.92	134	201	Peak

Remarks:

1. Emission Level = Read Level + Antenna Factor + Cable Loss - Preamp Factor  
Margin value = Emission level – Limit value
2. 2472 MHz: Fundamental frequency.
3. The other emission levels were very low against the limit.

802.11n (HT20)

EUT Test Condition		Measurement Detail	
Channel	Channel 1	Frequency Range	1 GHz ~ 25 GHz
Input Power	120 Vac, 60 Hz	Detector Function	Peak (PK) Average (AV)
Environmental Conditions	25 deg. C, 65 % RH	Tested By	Thomas Wei

Horizontal

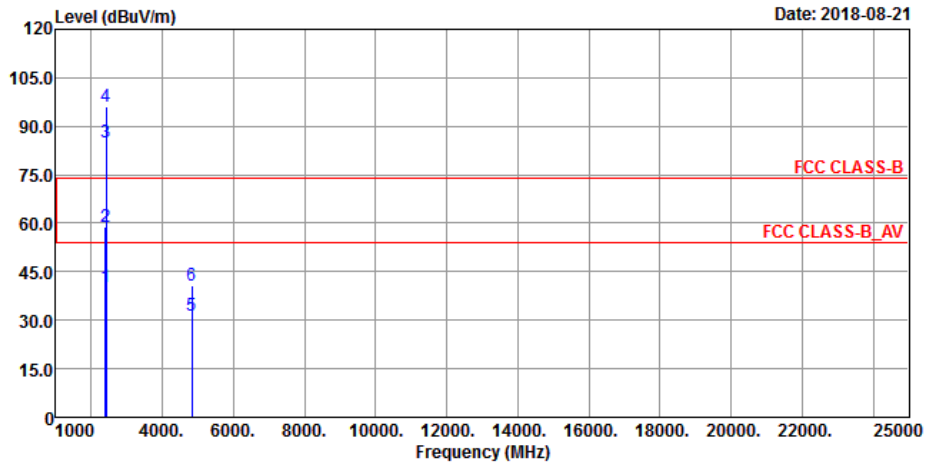

Vertical

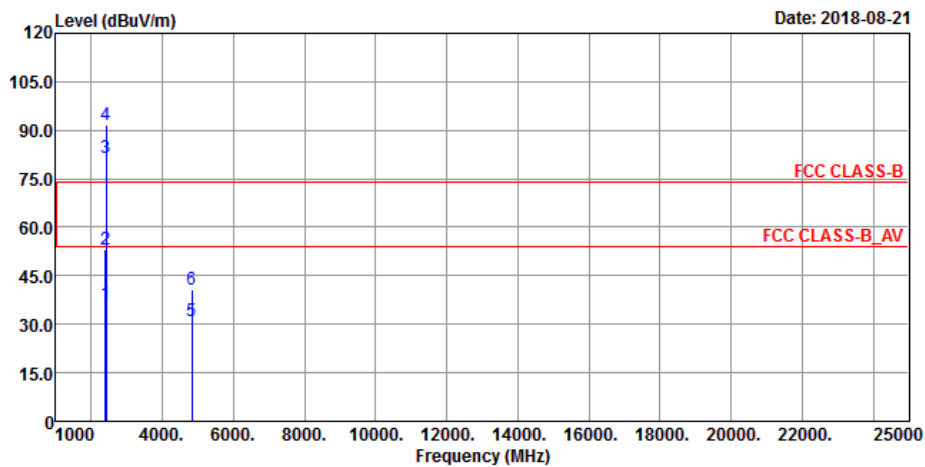

Antenna Polarity & Test Distance: Horizontal at 3 m										
Frequency (MHz)	Emission Level (dBuV/m)	Read Level (dBuV)	Limit (dBuV/m)	Margin (dB)	Antenna Factor (dB/m)	Cable Loss (dB)	Preamp Factor (dB)	Antenna Height (cm)	Table Angle (Degree)	Remark
2389.94	40.37	46.37	54	-13.63	27.16	4.36	37.52	179	233	Average
2389.94	58.76	64.76	74	-15.24	27.16	4.36	37.52	179	233	Peak
2412	85.18	91.09			27.23	4.38	37.52	179	233	Average
2412	96.28	102.19			27.23	4.38	37.52	179	233	Peak
4824	31.49	47.11	54	-22.51	31.17	6.1	52.89	124	211	Average
4824	40.69	56.31	74	-33.31	31.17	6.1	52.89	124	211	Peak
Antenna Polarity & Test Distance: Vertical at 3 m										
Frequency (MHz)	Emission Level (dBuV/m)	Read Level (dBuV)	Limit (dBuV/m)	Margin (dB)	Antenna Factor (dB/m)	Cable Loss (dB)	Preamp Factor (dB)	Antenna Height (cm)	Table Angle (Degree)	Remark
2389.94	36.52	42.52	54	-17.48	27.16	4.36	37.52	184	293	Average
2389.94	53.09	59.09	74	-20.91	27.16	4.36	37.52	184	293	Peak
2412	81.61	87.52			27.23	4.38	37.52	184	293	Average
2412	91.57	97.48			27.23	4.38	37.52	184	293	Peak
4824	31	46.62	54	-23	31.17	6.1	52.89	117	305	Average
4824	40.79	56.41	74	-33.21	31.17	6.1	52.89	117	305	Peak

Remarks:

1. Emission Level = Read Level + Antenna Factor + Cable Loss - Preamp Factor  
Margin value = Emission level – Limit value
2. 2412 MHz: Fundamental frequency.
3. The other emission levels were very low against the limit.

EUT Test Condition		Measurement Detail	
Channel	Channel 6	Frequency Range	1 GHz ~ 25 GHz
Input Power	120 Vac, 60 Hz	Detector Function	Peak (PK) Average (AV)
Environmental Conditions	25 deg. C, 65 % RH	Tested By	Thomas Wei

### Horizontal

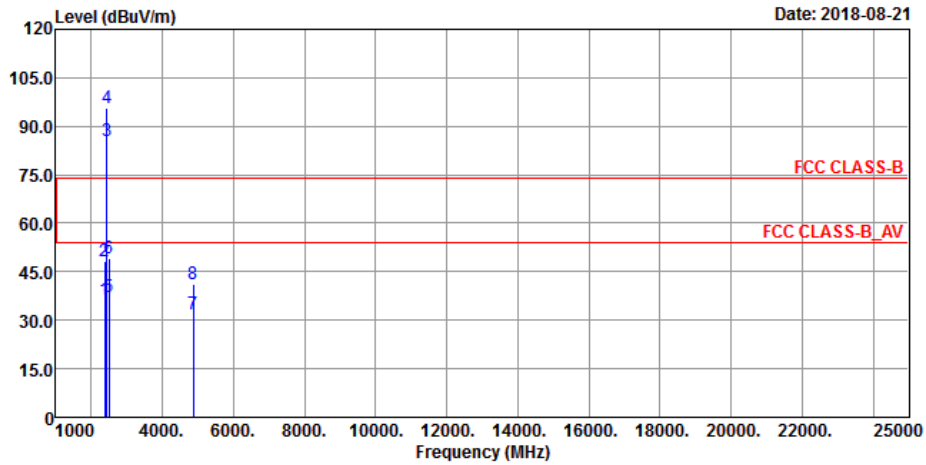

### Vertical

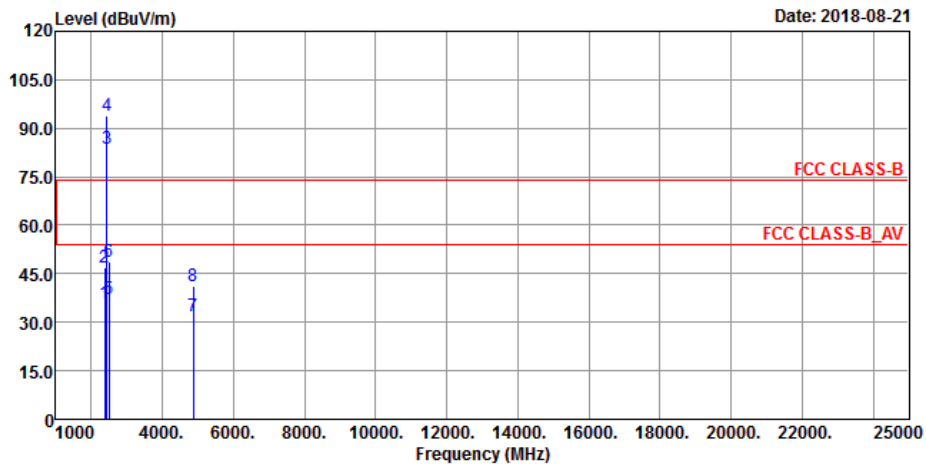

**Antenna Polarity & Test Distance: Horizontal at 3 m**

Frequency (MHz)	Emission Level (dBuV/m)	Read Level (dBuV)	Limit (dBuV/m)	Margin (dB)	Antenna Factor (dB/m)	Cable Loss (dB)	Preamp Factor (dB)	Antenna Height (cm)	Table Angle (Degree)	Remark
2371.66	36.49	42.56	54	-17.51	27.08	4.35	37.5	206	191	Average
2371.66	48.37	54.44	74	-25.63	27.08	4.35	37.5	206	191	Peak
2437	85.64	91.32			27.38	4.4	37.46	206	191	Average
2437	95.5	101.18			27.38	4.4	37.46	206	191	Peak
2486.44	37.01	42.29	54	-16.99	27.61	4.43	37.32	206	191	Average
2486.44	49.03	54.31	74	-24.97	27.61	4.43	37.32	206	191	Peak
4874	32.04	47.5	54	-21.96	31.25	6.15	52.86	170	206	Average
4874	41.25	56.71	74	-32.75	31.25	6.15	52.86	170	206	Peak

**Antenna Polarity & Test Distance: Vertical at 3 m**

Frequency (MHz)	Emission Level (dBuV/m)	Read Level (dBuV)	Limit (dBuV/m)	Margin (dB)	Antenna Factor (dB/m)	Cable Loss (dB)	Preamp Factor (dB)	Antenna Height (cm)	Table Angle (Degree)	Remark
2381.56	35.71	41.78	54	-18.29	27.08	4.35	37.5	161	357	Average
2381.56	47.06	53.13	74	-26.94	27.08	4.35	37.5	161	357	Peak
2437	83.85	89.53			27.38	4.4	37.46	161	357	Average
2437	93.95	99.63			27.38	4.4	37.46	161	357	Peak
2494.17	37.21	42.49	54	-16.79	27.61	4.43	37.32	161	357	Average
2494.17	48.58	53.86	74	-25.42	27.61	4.43	37.32	161	357	Peak
4874	31.77	47.23	54	-22.23	31.25	6.15	52.86	122	183	Average
4874	41.01	56.47	74	-32.99	31.25	6.15	52.86	122	183	Peak

Remarks:

- Emission Level = Read Level + Antenna Factor + Cable Loss - Preamp Factor  
Margin value = Emission level – Limit value
- 2437 MHz: Fundamental frequency.
- The other emission levels were very low against the limit.



EUT Test Condition		Measurement Detail	
Channel	Channel 11	Frequency Range	1 GHz ~ 25 GHz
Input Power	120 Vac, 60 Hz	Detector Function	Peak (PK) Average (AV)
Environmental Conditions	25 deg. C, 65 % RH	Tested By	Thomas Wei

### Horizontal

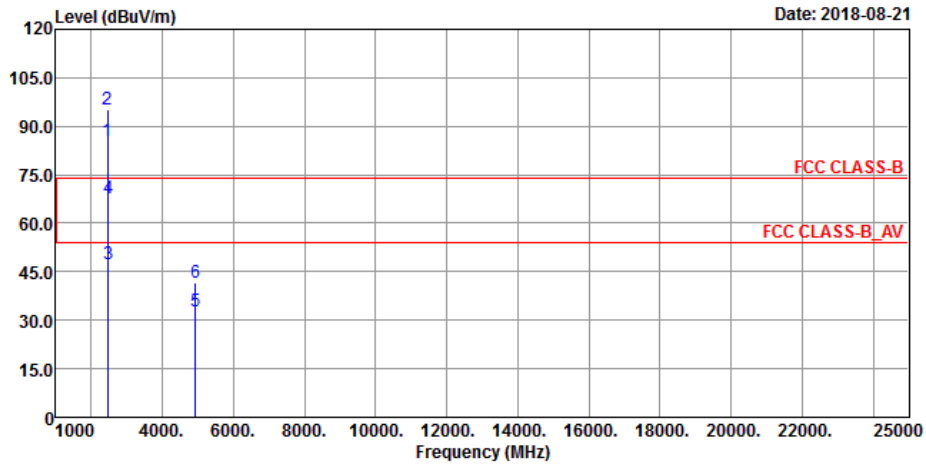

### Vertical

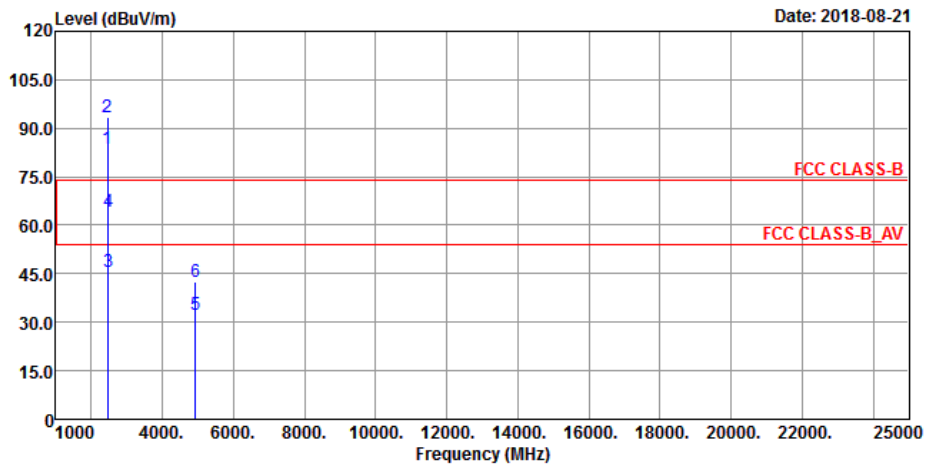

Antenna Polarity & Test Distance: Horizontal at 3 m										
Frequency (MHz)	Emission Level (dBuV/m)	Read Level (dBuV)	Limit (dBuV/m)	Margin (dB)	Antenna Factor (dB/m)	Cable Loss (dB)	Preamp Factor (dB)	Antenna Height (cm)	Table Angle (Degree)	Remark
2462	85.37	90.89			27.46	4.41	37.39	157	213	Average
2462	95.17	100.69			27.46	4.41	37.39	157	213	Peak
2483.52	47.26	52.62	54	-6.74	27.53	4.43	37.32	157	213	Average
2483.52	67.61	72.97	74	-6.39	27.53	4.43	37.32	157	213	Peak
4924	32.63	47.29	54	-21.37	31.34	6.89	52.89	107	134	Average
4924	41.77	56.43	74	-32.23	31.34	6.89	52.89	107	134	Peak
Antenna Polarity & Test Distance: Vertical at 3 m										
Frequency (MHz)	Emission Level (dBuV/m)	Read Level (dBuV)	Limit (dBuV/m)	Margin (dB)	Antenna Factor (dB/m)	Cable Loss (dB)	Preamp Factor (dB)	Antenna Height (cm)	Table Angle (Degree)	Remark
2462	83.62	89.14			27.46	4.41	37.39	145	193	Average
2462	93.65	99.17			27.46	4.41	37.39	145	193	Peak
2483.52	45.63	50.99	54	-8.37	27.53	4.43	37.32	145	193	Average
2483.52	64.33	69.69	74	-9.67	27.53	4.43	37.32	145	193	Peak
4924	32.18	46.84	54	-21.82	31.34	6.89	52.89	162	139	Average
4924	42.56	57.22	74	-31.44	31.34	6.89	52.89	162	139	Peak

Remarks:

1. Emission Level = Read Level + Antenna Factor + Cable Loss - Preamp Factor  
Margin value = Emission level – Limit value
2. 2462 MHz: Fundamental frequency.
3. The other emission levels were very low against the limit.

EUT Test Condition		Measurement Detail	
Channel	Channel 12	Frequency Range	1 GHz ~ 25 GHz
Input Power	120 Vac, 60 Hz	Detector Function	Peak (PK) Average (AV)
Environmental Conditions	25 deg. C, 65 % RH	Tested By	Thomas Wei

### Horizontal

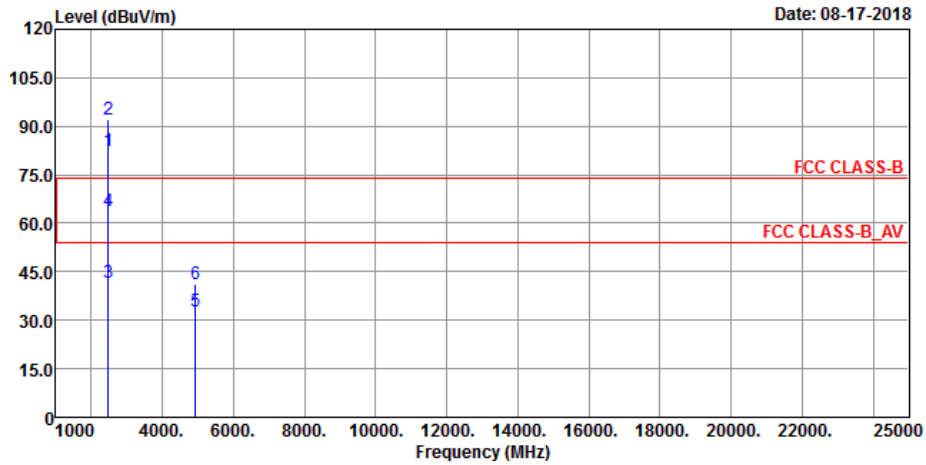

### Vertical

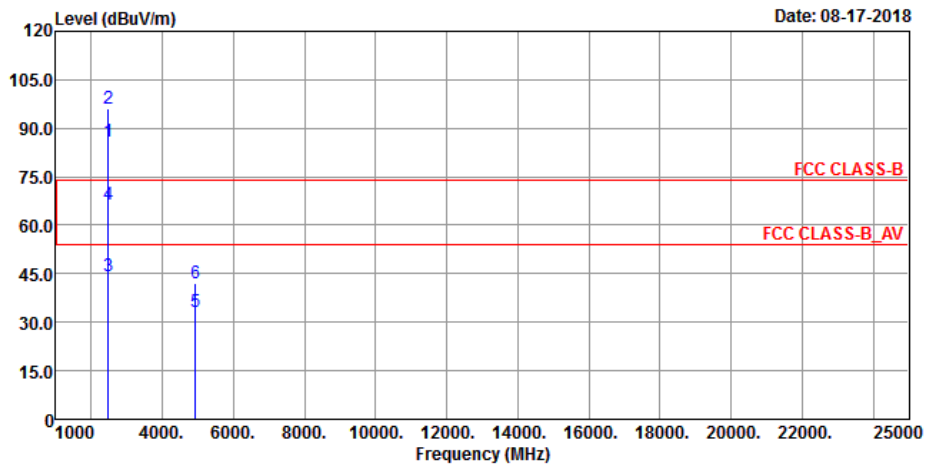

Antenna Polarity & Test Distance: Horizontal at 3 m										
Frequency (MHz)	Emission Level (dBuV/m)	Read Level (dBuV)	Limit (dBuV/m)	Margin (dB)	Antenna Factor (dB/m)	Cable Loss (dB)	Preamp Factor (dB)	Antenna Height (cm)	Table Angle (Degree)	Remark
2467	82.46	87.9			27.46	4.42	37.32	161	147	Average
2467	92.24	97.68			27.46	4.42	37.32	161	147	Peak
2483.6	41.76	47.12	54	-12.24	27.53	4.43	37.32	161	147	Average
2483.6	63.7	69.06	74	-10.3	27.53	4.43	37.32	161	147	Peak
4934	32.86	47.52	54	-21.14	31.34	6.89	52.89	162	64	Average
4934	41.32	55.98	74	-32.68	31.34	6.89	52.89	162	64	Peak
Antenna Polarity & Test Distance: Vertical at 3 m										
Frequency (MHz)	Emission Level (dBuV/m)	Read Level (dBuV)	Limit (dBuV/m)	Margin (dB)	Antenna Factor (dB/m)	Cable Loss (dB)	Preamp Factor (dB)	Antenna Height (cm)	Table Angle (Degree)	Remark
2467	86.06	91.5			27.46	4.42	37.32	116	169	Average
2467	95.92	101.36			27.46	4.42	37.32	116	169	Peak
2483.52	44.48	49.84	54	-9.52	27.53	4.43	37.32	116	169	Average
2483.52	66.44	71.8	74	-7.56	27.53	4.43	37.32	116	169	Peak
4934	33.38	48.04	54	-20.62	31.34	6.89	52.89	129	254	Average
4934	42.23	56.89	74	-31.77	31.34	6.89	52.89	129	254	Peak

Remarks:

1. Emission Level = Read Level + Antenna Factor + Cable Loss - Preamp Factor  
Margin value = Emission level – Limit value
2. 2467 MHz: Fundamental frequency.
3. The other emission levels were very low against the limit.

EUT Test Condition		Measurement Detail	
Channel	Channel 13	Frequency Range	1 GHz ~ 25 GHz
Input Power	120 Vac, 60 Hz	Detector Function	Peak (PK) Average (AV)
Environmental Conditions	25 deg. C, 65 % RH	Tested By	Thomas Wei

### Horizontal

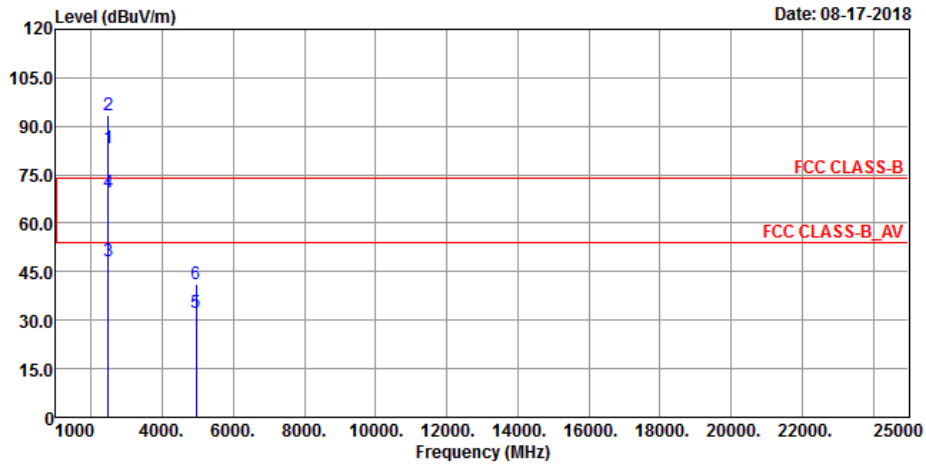

### Vertical

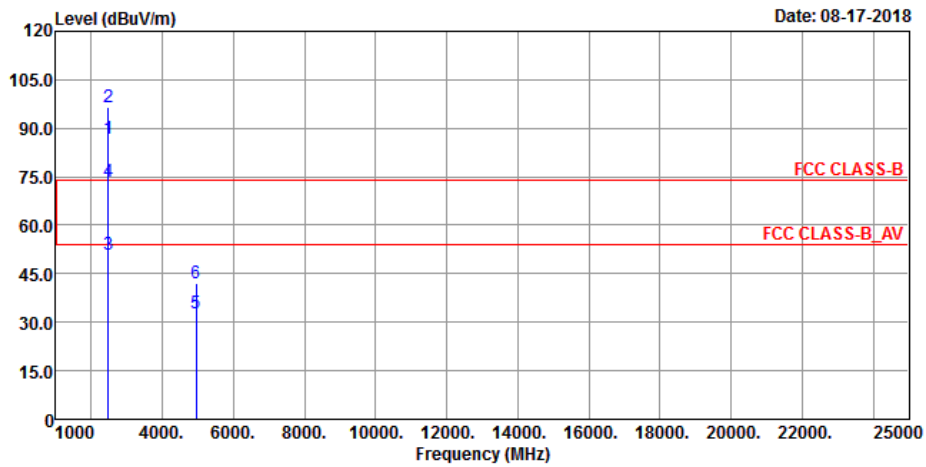

Antenna Polarity & Test Distance: Horizontal at 3 m										
Frequency (MHz)	Emission Level (dBuV/m)	Read Level (dBuV)	Limit (dBuV/m)	Margin (dB)	Antenna Factor (dB/m)	Cable Loss (dB)	Preamp Factor (dB)	Antenna Height (cm)	Table Angle (Degree)	Remark
2472	83.46	88.83			27.53	4.42	37.32	162	148	Average
2472	93.26	98.63			27.53	4.42	37.32	162	148	Peak
2483.52	48.18	53.54	54	-5.82	27.53	4.43	37.32	162	148	Average
2483.52	69.53	74.89	74	-4.47	27.53	4.43	37.32	162	148	Peak
4944	32.26	47.62	54	-21.74	31.37	6.19	52.92	163	201	Average
4944	41.22	56.58	74	-32.78	31.37	6.19	52.92	163	201	Peak
Antenna Polarity & Test Distance: Vertical at 3 m										
Frequency (MHz)	Emission Level (dBuV/m)	Read Level (dBuV)	Limit (dBuV/m)	Margin (dB)	Antenna Factor (dB/m)	Cable Loss (dB)	Preamp Factor (dB)	Antenna Height (cm)	Table Angle (Degree)	Remark
2472	86.82	92.19			27.53	4.42	37.32	118	174	Average
2472	96.54	101.91			27.53	4.42	37.32	118	174	Peak
2483.52	50.9	56.26	54	-3.1	27.53	4.43	37.32	118	174	Average
2483.52	73.51	78.87	74	-0.49	27.53	4.43	37.32	118	174	Peak
4944	32.56	47.92	54	-21.44	31.37	6.19	52.92	177	139	Average
4944	42.06	57.42	74	-31.94	31.37	6.19	52.92	177	139	Peak

Remarks:

1. Emission Level = Read Level + Antenna Factor + Cable Loss - Preamp Factor  
Margin value = Emission level – Limit value
2. 2472 MHz: Fundamental frequency.
3. The other emission levels were very low against the limit.

**9 kHz ~ 30 MHz Data:**

The amplitude of spurious emissions attenuated more than 20 dB below the permissible value is not required to be report.

**30 MHz ~ 1 GHz Worst-Case Data:**

**Mode A**

**802.11n (HT20)**

EUT Test Condition		Measurement Detail	
Channel	Channel 13	Frequency Range	30 MHz ~ 1 GHz
Input Power	120 Vac, 60 Hz	Detector Function	Peak (PK) Quasi-peak (QP)
Environmental Conditions	25 deg. C, 65 % RH	Tested By	Thomas Wei

**Horizontal**

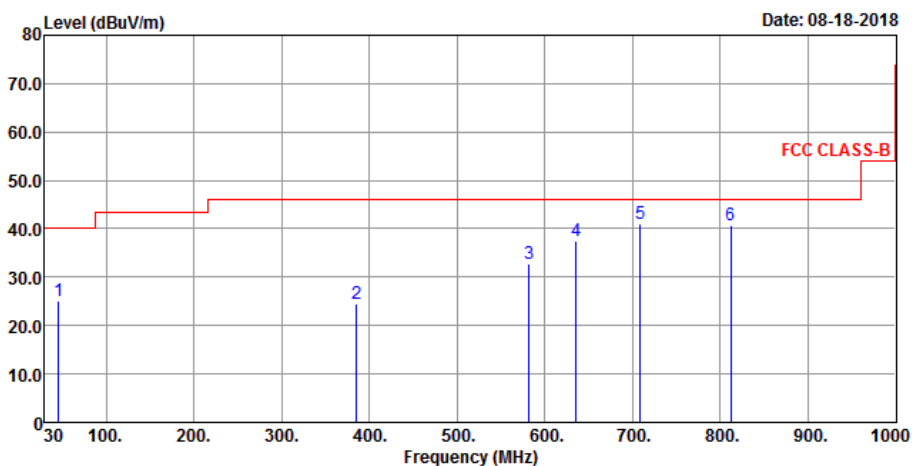

**Vertical**

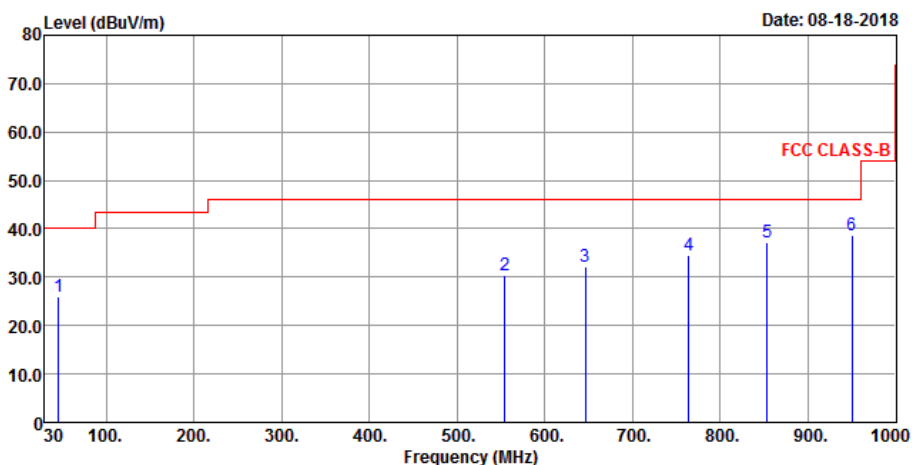

**Antenna Polarity & Test Distance: Horizontal at 3 m**

Frequency (MHz)	Emission Level (dBuV/m)	Read Level (dBuV)	Limit (dBuV/m)	Margin (dB)	Antenna Factor (dB/m)	Cable Loss (dB)	Preamp Factor (dB)	Antenna Height (cm)	Table Angle (Degree)	Remark
45.52	25.08	42.23	40	-14.92	13.5	0.51	31.16	149	337	Peak
385.02	24.61	39.6	46	-21.39	14.98	2.03	32	177	261	Peak
581.93	32.85	42.95	46	-13.15	19.19	2.83	32.12	194	207	Peak
635.28	37.38	46.41	46	-8.62	20.03	3.05	32.11	182	239	Peak
709	40.99	48.44	46	-5.01	20.94	3.35	31.74	246	255	Peak
811.82	40.65	46.03	46	-5.35	22.38	3.72	31.48	288	313	Peak

**Antenna Polarity & Test Distance: Vertical at 3 m**

Frequency (MHz)	Emission Level (dBuV/m)	Read Level (dBuV)	Limit (dBuV/m)	Margin (dB)	Antenna Factor (dB/m)	Cable Loss (dB)	Preamp Factor (dB)	Antenna Height (cm)	Table Angle (Degree)	Remark
45.52	26.02	43.17	40	-13.98	13.5	0.51	31.16	113	314	Peak
554.77	30.35	41.07	46	-15.65	18.57	2.72	32.01	158	287	Peak
645.95	32.04	40.84	46	-13.96	20.16	3.09	32.05	189	183	Peak
764.29	34.64	40.76	46	-11.36	21.72	3.55	31.39	199	173	Peak
853.53	37.1	42.21	46	-8.9	22.91	3.86	31.88	248	126	Peak
950.53	38.56	42.36	46	-7.44	23.79	4.24	31.83	269	69	Peak

**Remarks:**

1. Emission Level = Read Level + Antenna Factor + Cable Loss - Preamp Factor  
Margin value = Emission level – Limit value
2. The other emission levels were very low against the limit.



**Mode B**

**802.11n (HT20)**

EUT Test Condition		Measurement Detail	
Channel	Channel 13	Frequency Range	30 MHz ~ 1 GHz
Input Power	120 Vac, 60 Hz	Detector Function	Peak (PK) Quasi-peak (QP)
Environmental Conditions	25 deg. C, 65 % RH	Tested By	Thomas Wei

**Horizontal**

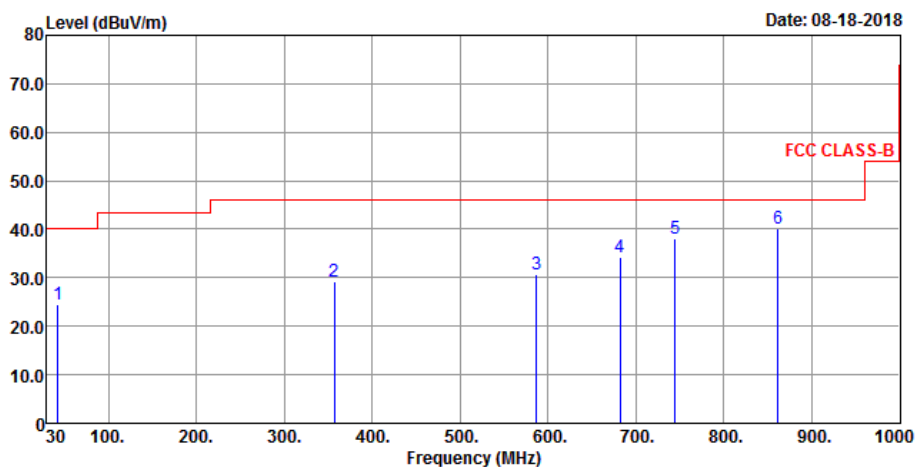

**Vertical**

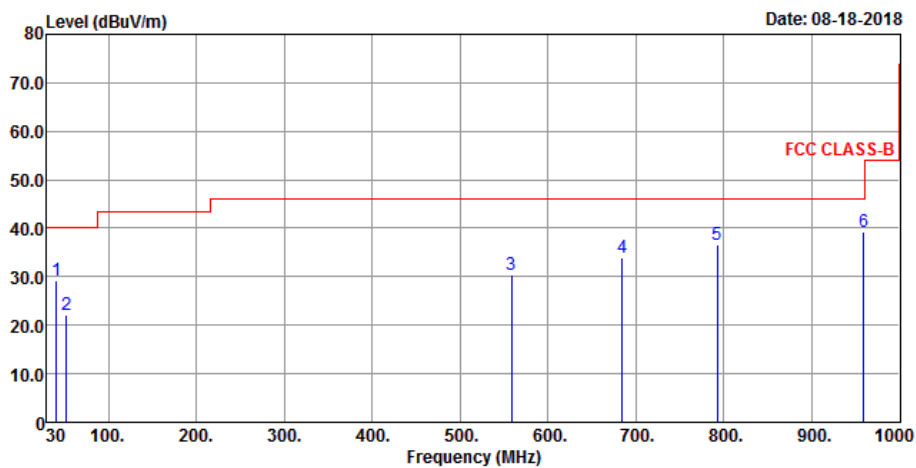

**Antenna Polarity & Test Distance: Horizontal at 3 m**

Frequency (MHz)	Emission Level (dBuV/m)	Read Level (dBuV)	Limit (dBuV/m)	Margin (dB)	Antenna Factor (dB/m)	Cable Loss (dB)	Preamp Factor (dB)	Antenna Height (cm)	Table Angle (Degree)	Remark
42.61	24.42	41.42	40	-15.58	13.58	0.5	31.08	134	333	Peak
356.89	29.32	45.03	46	-16.68	14.31	1.91	31.93	159	288	Peak
586.78	30.81	40.8	46	-15.19	19.3	2.84	32.13	188	212	Peak
681.84	34.2	42.21	46	-11.8	20.6	3.23	31.84	233	166	Peak
744.89	38.21	44.66	46	-7.79	21.45	3.49	31.39	257	119	Peak
861.29	40.06	45.07	46	-5.94	23.01	3.89	31.91	277	66	Peak

**Antenna Polarity & Test Distance: Vertical at 3 m**

Frequency (MHz)	Emission Level (dBuV/m)	Read Level (dBuV)	Limit (dBuV/m)	Margin (dB)	Antenna Factor (dB/m)	Cable Loss (dB)	Preamp Factor (dB)	Antenna Height (cm)	Table Angle (Degree)	Remark
40.67	29.27	46.25	40	-10.73	13.55	0.49	31.02	288	155	Peak
52.31	22.07	40.09	40	-17.93	12.76	0.54	31.32	255	173	Peak
558.65	30.35	41.01	46	-15.65	18.66	2.73	32.05	166	67	Peak
684.75	33.89	41.86	46	-12.11	20.63	3.24	31.84	249	115	Peak
792.42	36.48	42.13	46	-9.52	22.12	3.64	31.41	201	188	Peak
959.26	39.19	43	46	-6.81	23.84	4.27	31.92	236	88	Peak

**Remarks:**

1. Emission Level = Read Level + Antenna Factor + Cable Loss - Preamp Factor  
Margin value = Emission level – Limit value
2. The other emission levels were very low against the limit.

## 4.18 Conducted Emission Measurement

### 4.18.1 Limits of Conducted Emission Measurement

Frequency (MHz)	Conducted Limit (dBuV)	
	Quasi-Peak	Average
0.15 - 0.5	66 - 56	56 - 46
0.50 - 5.0	56	46
5.0 - 30.0	60	50

- Note: 1. The lower limit shall apply at the transition frequencies.  
 2. The limit decreases in line with the logarithm of the frequency in the range of 0.15 to 0.50 MHz.

### 4.18.2 Test Instruments

Refer to section 4.2.2 to get information of the instrument.

### 4.18.3 Test Procedures

- The EUT was placed 0.4 meters from the conducting wall of the shielded room with EUT being connected to the power mains through a line impedance stabilization network (LISN). Other support units were connected to the power mains through another LISN. The two LISNs provide 50 ohm/50 uH of coupling impedance for the measuring instrument.
- Both lines of the power mains connected to the EUT were checked for maximum conducted interference.
- The frequency range from 150 kHz to 30 MHz was searched. Emission levels under (Limit – 20 dB) was not recorded.

**Note:** The resolution bandwidth and video bandwidth of test receiver is 9 kHz for quasi-peak detection (QP) and average detection (AV) at frequency 0.15 MHz – 30 MHz.

### 4.18.4 Deviation from Test Standard

No deviation.

#### 4.18.5 Test Setup

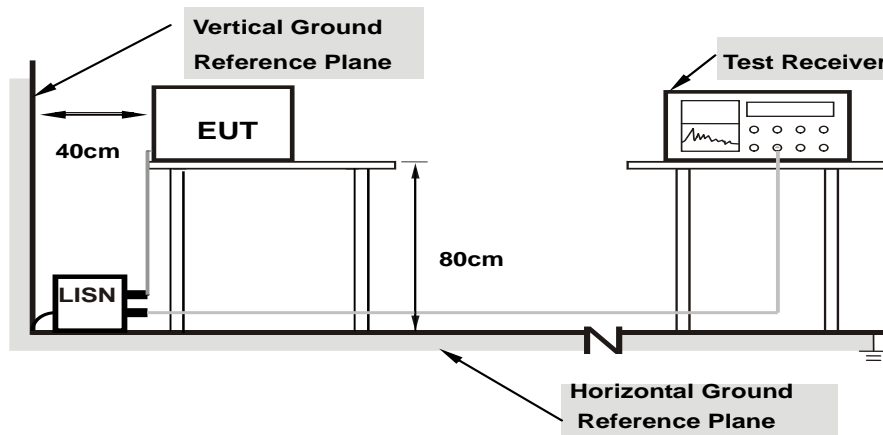

**Note: 1.Support units were connected to second LISN.**

For the actual test configuration, please refer to the attached file (Test Setup Photo).

#### 4.18.6 EUT Operating Conditions

- Placed the EUT on a testing table.
- Use the software to control the EUT under transmission condition continuously at specific channel frequency.

#### 4.18.7 Test Results

##### Mode A

Frequency Range	150kHz ~ 30MHz	Detector Function & Resolution Bandwidth	Quasi-Peak (QP) / Average (AV), 9kHz
Input Power	120Vac, 60Hz	Environmental Conditions	25°C, 65%RH
Tested by	Jisyong Wang	Test Date	2018/7/21

Phase Of Power : Line (L)										
No	Frequency (MHz)	Correction Factor (dB)	Reading Value (dBuV)		Emission Level (dBuV)		Limit (dBuV)		Margin (dB)	
			Q.P.	AV.	Q.P.	AV.	Q.P.	AV.	Q.P.	AV.
1	0.15782	9.67	30.84	10.27	40.51	19.94	65.58	55.58	-25.07	-35.64
2	0.20084	9.67	31.39	6.90	41.06	16.57	63.58	53.58	-22.52	-37.01
3	0.25557	9.67	30.09	9.75	39.76	19.42	61.57	51.57	-21.81	-32.15
4	0.61529	9.67	27.31	12.41	36.98	22.08	56.00	46.00	-19.02	-23.92
5	9.91718	9.87	24.24	7.02	34.11	16.89	60.00	50.00	-25.89	-33.11
6	17.74109	9.93	21.31	7.55	31.24	17.48	60.00	50.00	-28.76	-32.52

##### Remarks:

1. Q.P. and AV. are abbreviations of quasi-peak and average individually.
2. The emission levels of other frequencies were very low against the limit.
3. Margin value = Emission level – Limit value
4. Correction factor = Insertion loss + Cable loss
5. Emission Level = Correction Factor + Reading Value

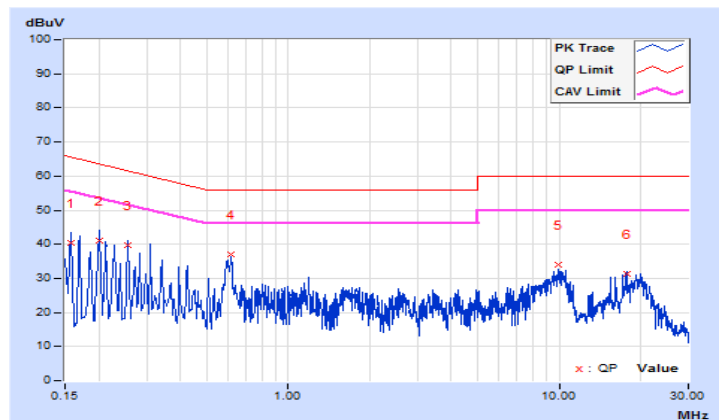

Frequency Range	150kHz ~ 30MHz	Detector Function & Resolution Bandwidth	Quasi-Peak (QP) / Average (AV), 9kHz
Input Power	120Vac, 60Hz	Environmental Conditions	25°C, 65%RH
Tested by	Jisyong Wang	Test Date	2018/7/21

Phase Of Power : Neutral (N)										
No	Frequency (MHz)	Correction Factor (dB)	Reading Value (dBuV)		Emission Level (dBuV)		Limit (dBuV)		Margin (dB)	
			Q.P.	AV.	Q.P.	AV.	Q.P.	AV.	Q.P.	AV.
1	0.16955	9.68	31.56	14.04	41.24	23.72	64.98	54.98	-23.74	-31.26
2	0.21256	9.68	29.68	12.87	39.36	22.55	63.10	53.10	-23.74	-30.55
3	0.33768	9.68	23.95	4.98	33.63	14.66	59.26	49.26	-25.63	-34.60
<b>4</b>	<b>0.59183</b>	<b>9.68</b>	<b>27.70</b>	<b>10.17</b>	<b>37.38</b>	<b>19.85</b>	<b>56.00</b>	<b>46.00</b>	<b>-18.62</b>	<b>-26.15</b>
5	9.78815	9.88	23.41	8.57	33.29	18.45	60.00	50.00	-26.71	-31.55
6	15.97377	9.98	20.11	7.89	30.09	17.87	60.00	50.00	-29.91	-32.13

Remarks:

1. Q.P. and AV. are abbreviations of quasi-peak and average individually.
2. The emission levels of other frequencies were very low against the limit.
3. Margin value = Emission level – Limit value
4. Correction factor = Insertion loss + Cable loss
5. Emission Level = Correction Factor + Reading Value

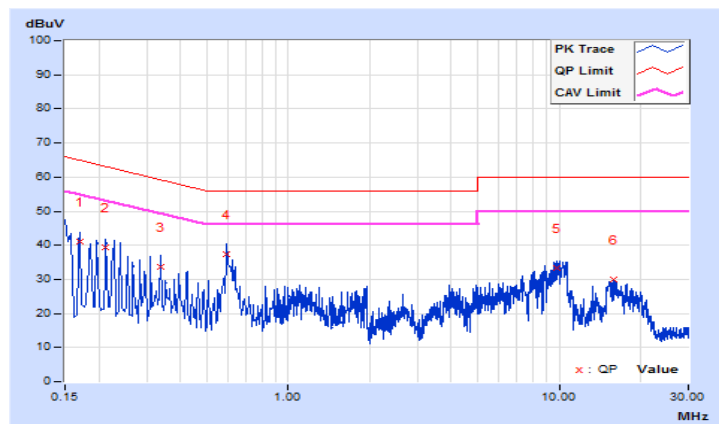

**Mode B**

Frequency Range	150kHz ~ 30MHz	Detector Function & Resolution Bandwidth	Quasi-Peak (QP) / Average (AV), 9kHz
Input Power	120Vac, 60Hz	Environmental Conditions	25°C, 65%RH
Tested by	Jisyong Wang	Test Date	2018/7/21

Phase Of Power : Line (L)										
No	Frequency (MHz)	Correction Factor (dB)	Reading Value (dBuV)		Emission Level (dBuV)		Limit (dBuV)		Margin (dB)	
			Q.P.	AV.	Q.P.	AV.	Q.P.	AV.	Q.P.	AV.
1	0.21256	9.67	30.06	11.29	39.73	20.96	63.10	53.10	-23.37	-32.14
2	0.35332	9.67	21.93	4.55	31.60	14.22	58.88	48.88	-27.28	-34.66
3	0.60356	9.67	25.03	10.54	34.70	20.21	56.00	46.00	-21.30	-25.79
4	9.10390	9.86	21.11	5.33	30.97	15.19	60.00	50.00	-29.03	-34.81
5	15.39900	9.91	21.31	5.49	31.22	15.40	60.00	50.00	-28.78	-34.60
6	20.95120	9.95	21.42	5.76	31.37	15.71	60.00	50.00	-28.63	-34.29

Remarks:

1. Q.P. and AV. are abbreviations of quasi-peak and average individually.
2. The emission levels of other frequencies were very low against the limit.
3. Margin value = Emission level – Limit value
4. Correction factor = Insertion loss + Cable loss
5. Emission Level = Correction Factor + Reading Value

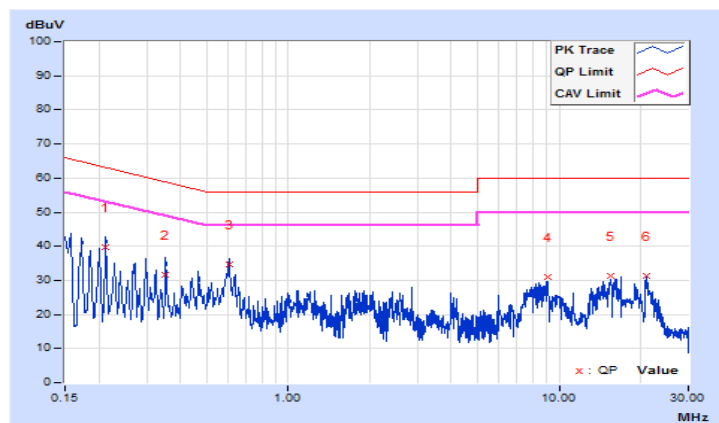

Frequency Range	150kHz ~ 30MHz	Detector Function & Resolution Bandwidth	Quasi-Peak (QP) / Average (AV), 9kHz
Input Power	120Vac, 60Hz	Environmental Conditions	25°C, 65%RH
Tested by	Jisyong Wang	Test Date	2018/7/21

Phase Of Power : Neutral (N)										
No	Frequency (MHz)	Correction Factor (dB)	Reading Value (dBuV)		Emission Level (dBuV)		Limit (dBuV)		Margin (dB)	
			Q.P.	AV.	Q.P.	AV.	Q.P.	AV.	Q.P.	AV.
1	0.18122	9.68	25.38	9.27	35.06	18.95	64.43	54.43	-29.37	-35.48
2	0.37678	9.68	21.71	9.50	31.39	19.18	58.35	48.35	-26.96	-29.17
3	0.60356	9.68	23.84	10.43	33.52	20.11	56.00	46.00	-22.48	-25.89
4	0.90895	9.69	21.62	3.47	31.31	13.16	56.00	46.00	-24.69	-32.84
5	9.00224	9.86	22.45	6.45	32.31	16.31	60.00	50.00	-27.69	-33.69
6	16.22401	9.99	19.52	6.17	29.51	16.16	60.00	50.00	-30.49	-33.84

Remarks:

1. Q.P. and AV. are abbreviations of quasi-peak and average individually.
2. The emission levels of other frequencies were very low against the limit.
3. Margin value = Emission level – Limit value
4. Correction factor = Insertion loss + Cable loss
5. Emission Level = Correction Factor + Reading Value

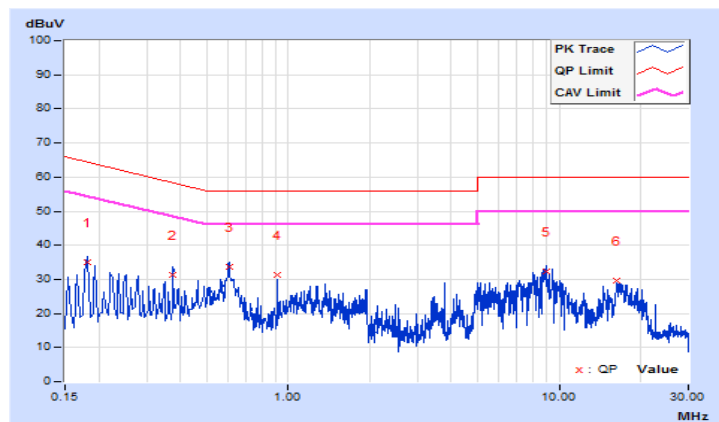



## 4.19 6 dB Bandwidth Measurement

### 4.19.1 Limits of 6 dB Bandwidth Measurement

The minimum of 6 dB Bandwidth Measurement is 0.5 MHz.

### 4.19.2 Test Setup

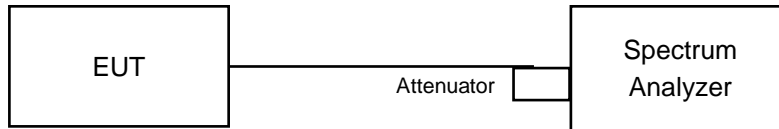

### 4.19.3 Test Instruments

Refer to section 4.1.2 to get information of above instrument.

### 4.19.4 Test Procedure

- a. Set resolution bandwidth (RBW) = 100 kHz
- b. Set the video bandwidth (VBW)  $\geq 3 \times$  RBW, Detector = Peak.
- c. Trace mode = max hold.
- d. Sweep = auto couple.
- e. Measure the maximum width of the emission that is constrained by the frequencies associated with the two amplitude points (upper and lower) that are attenuated by 6 dB relative to the maximum level measured in the fundamental emission

### 4.19.5 Deviation from Test Standard

No deviation.

### 4.19.6 EUT Operating Conditions

The software provided by client to enable the EUT under transmission condition continuously at lowest, middle and highest channel frequencies individually.

## 4.19.7 Test Results

## 802.11b

Channel	Frequency (MHz)	6 dB Bandwidth (MHz)	Minimum Limit (MHz)	Pass / Fail
1	2412	9.06	0.5	Pass
6	2437	8.09	0.5	Pass
11	2462	8.10	0.5	Pass
12	2467	8.10	0.5	Pass
13	2472	8.09	0.5	Pass

## 802.11g

Channel	Frequency (MHz)	6 dB Bandwidth (MHz)	Minimum Limit (MHz)	Pass / Fail
1	2412	16.40	0.5	Pass
6	2437	16.41	0.5	Pass
11	2462	16.41	0.5	Pass
12	2467	16.40	0.5	Pass
13	2472	16.40	0.5	Pass

## 802.11n (HT20)

Channel	Frequency (MHz)	6 dB Bandwidth (MHz)	Minimum Limit (MHz)	Pass / Fail
1	2412	17.63	0.5	Pass
6	2437	17.66	0.5	Pass
11	2462	17.65	0.5	Pass
12	2467	17.64	0.5	Pass
13	2472	17.63	0.5	Pass

### Spectrum Plot of Worst Value

#### 802.11b

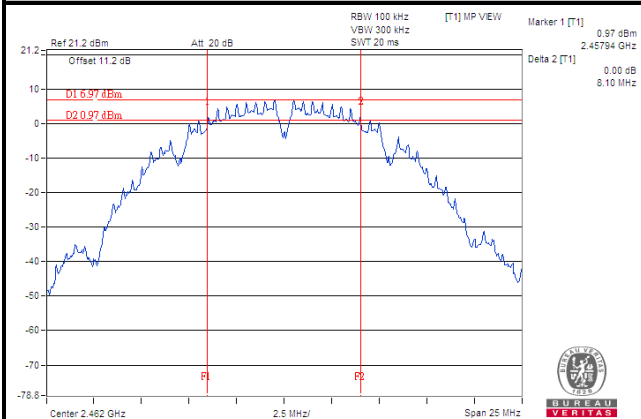

#### 802.11g

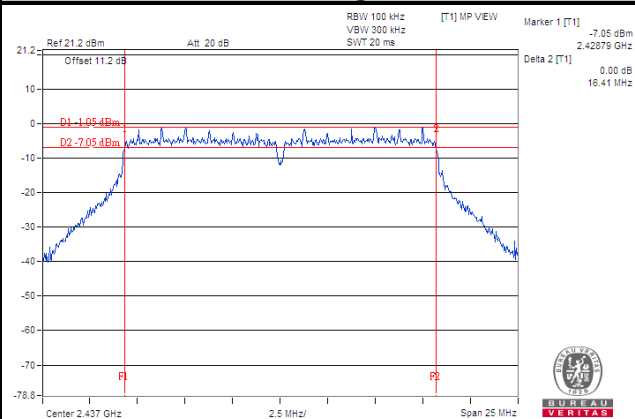

#### 802.11n (HT20)

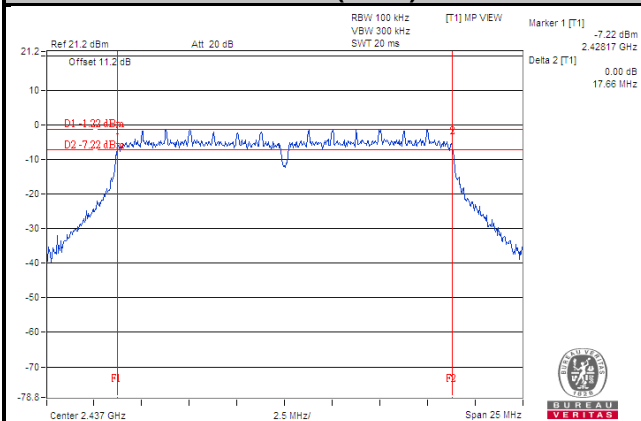

## 4.20 Occupied Bandwidth Measurement

### 4.20.1 Test Setup

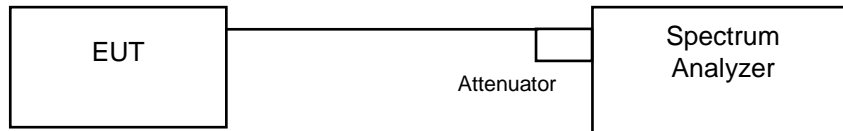

### 4.20.2 Test Instruments

Refer to section 4.1.2 to get information of above instrument.

### 4.20.3 Test Procedure

The transmitter output was connected to the spectrum analyzer through an attenuator. The bandwidth of the fundamental frequency was measured by spectrum analyzer with resolution bandwidth in the range of 1 % to 5 % of the anticipated emission bandwidth, and a video bandwidth at least 3x the resolution bandwidth and set the detector to PEAK. The width of a frequency band such that, below the lower and above the upper frequency limits, the mean powers emitted are each equal to a specified percentage 0.5 % of the total mean power of a given emission.

### 4.20.4 Deviation from Test Standard

No deviation.

### 4.20.5 EUT Operating Conditions

The software provided by client to enable the EUT under transmission condition continuously at lowest, middle and highest channel frequencies individually.

#### 4.20.6 Test Results

##### 802.11b

Channel	Frequency (MHz)	Occupied Bandwidth (MHz)	Pass / Fail
1	2412	13.26	Pass
6	2437	13.26	Pass
11	2462	13.26	Pass
12	2467	13.08	Pass
13	2472	13.17	Pass

##### 802.11g

Channel	Frequency (MHz)	Occupied Bandwidth (MHz)	Pass / Fail
1	2412	17.12	Pass
6	2437	17.11	Pass
11	2462	17.21	Pass
12	2467	16.92	Pass
13	2472	17.02	Pass

##### 802.11n (HT20)

Channel	Frequency (MHz)	Occupied Bandwidth (MHz)	Pass / Fail
1	2412	18.08	Pass
6	2437	18.17	Pass
11	2462	18.08	Pass
12	2467	18.07	Pass
13	2472	18.08	Pass



## 4.21 Conducted Output Power Measurement

### 4.21.1 Limits of Conducted Output Power Measurement

For systems using digital modulation in the 2400–2483.5 MHz bands: 1 Watt (30 dBm)

### 4.21.2 Test Setup

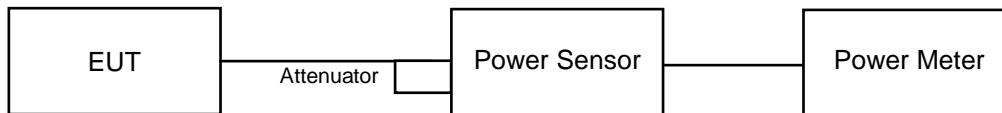

### 4.21.3 Test Instruments

Refer to section 4.1.2 to get information of above instrument.

### 4.21.4 Test Procedures

A peak power sensor was used on the output port of the EUT. A power meter was used to read the response of the peak power sensor. Record the power level.

### 4.21.5 Deviation from Test Standard

No deviation.

### 4.21.6 EUT Operating Conditions

The software provided by client to enable the EUT under transmission condition continuously at lowest, middle and highest channel frequencies individually.

#### 4.21.7 Test Results

##### 802.11b

Channel	Frequency (MHz)	Peak Power (mW)	Peak Power (dBm)	Limit (dBm)	Pass / Fail
1	2412	72.611	18.61	30	Pass
6	2437	77.446	18.89	30	Pass
11	2462	68.234	18.34	30	Pass
12	2467	71.614	18.55	30	Pass
13	2472	70.958	18.51	30	Pass

##### 802.11g

Channel	Frequency (MHz)	Peak Power (mW)	Peak Power (dBm)	Limit (dBm)	Pass / Fail
1	2412	90.573	19.57	30	Pass
6	2437	84.723	19.28	30	Pass
11	2462	86.497	19.37	30	Pass
12	2467	87.297	19.41	30	Pass
13	2472	86.497	19.37	30	Pass

##### 802.11n (HT20)

Channel	Frequency (MHz)	Peak Power (mW)	Peak Power (dBm)	Limit (dBm)	Pass / Fail
1	2412	87.297	19.41	30	Pass
6	2437	83.946	19.24	30	Pass
11	2462	93.541	19.71	30	Pass
12	2467	89.125	19.50	30	Pass
13	2472	87.902	19.44	30	Pass



## 4.22 Power Spectral Density Measurement

### 4.22.1 Limits of Power Spectral Density Measurement

The Maximum of Power Spectral Density Measurement is 8 dBm.

### 4.22.2 Test Setup

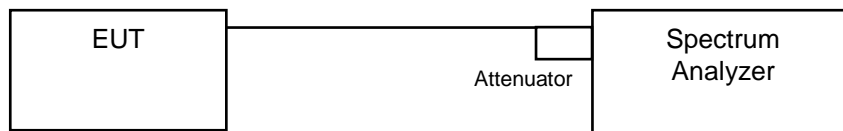

### 4.22.3 Test Instruments

Refer to section 4.1.2 to get information of above instrument.

### 4.22.4 Test Procedure

- a. Set analyzer center frequency to DTS channel center frequency.
- b. Set the span to 1.5 times the DTS bandwidth.
- c. Set the RBW to:  $3 \text{ kHz} \leq \text{RBW} \leq 100 \text{ kHz}$ .
- d. Set the VBW  $\geq 3 \times \text{RBW}$ .
- e. Detector = peak.
- f. Sweep time = auto couple.
- g. Trace mode = max hold.
- h. Allow trace to fully stabilize.
- i. Use the peak marker function to determine the maximum amplitude level within the RBW.

### 4.22.5 Deviation from Test Standard

No deviation.

### 4.22.6 EUT Operating Condition

The software provided by client to enable the EUT under transmission condition continuously at lowest, middle and highest channel frequencies individually.

#### 4.22.7 Test Results

##### 802.11b

Channel	Frequency (MHz)	PSD (dBm/3 kHz)	Limit (dBm/3 kHz)	Pass / Fail
1	2412	-7.45	8	Pass
6	2437	-7.24	8	Pass
11	2462	-8.08	8	Pass
12	2467	-7.37	8	Pass
13	2472	-7.10	8	Pass

##### 802.11g

Channel	Frequency (MHz)	PSD (dBm/3 kHz)	Limit (dBm/3 kHz)	Pass / Fail
1	2412	-16.05	8	Pass
6	2437	-15.53	8	Pass
11	2462	-15.40	8	Pass
12	2467	-15.50	8	Pass
13	2472	-15.43	8	Pass

##### 802.11n (HT20)

Channel	Frequency (MHz)	PSD (dBm/3 kHz)	Limit (dBm/3 kHz)	Pass / Fail
1	2412	-15.64	8	Pass
6	2437	-16.42	8	Pass
11	2462	-16.65	8	Pass
12	2467	-16.35	8	Pass
13	2472	-15.82	8	Pass



## 4.23 Conducted Out of Band Emission Measurement

### 4.23.1 Limits of Conducted Out of Band Emission Measurement

Below -20 dB of the highest emission level of operating band (in 100 kHz Resolution Bandwidth).

### 4.23.2 Test Setup

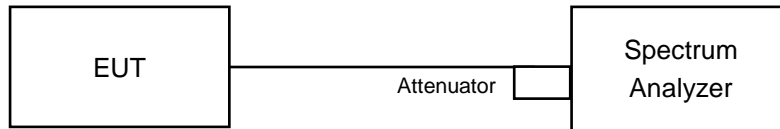

### 4.23.3 Test Instruments

Refer to section 4.1.2 to get information of above instrument.

### 4.23.4 Test Procedure

#### MEASUREMENT PROCEDURE REF

1. Set the RBW = 100 kHz.
2. Set the VBW  $\geq$  300 kHz.
3. Detector = peak.
4. Sweep time = auto couple.
5. Trace mode = max hold.
6. Allow trace to fully stabilize.
7. Use the peak marker function to determine the maximum power level in any 100 kHz band segment within the fundamental EBW.

#### MEASUREMENT PROCEDURE OOB

1. Set RBW = 100 kHz.
2. Set VBW  $\geq$  300 kHz.
3. Detector = peak.
4. Sweep = auto couple.
5. Trace Mode = max hold.
6. Allow trace to fully stabilize.
7. Use the peak marker function to determine the maximum amplitude level.

### 4.23.5 Deviation from Test Standard

No deviation.

### 4.23.6 EUT Operating Condition

The software provided by client to enable the EUT under transmission condition continuously at lowest, middle and highest channel frequencies individually.

### 4.23.7 Test Results

The spectrum plots are attached on the following images. D1 line indicates the highest level, and D2 line indicates the 20 dB offset below D1. It shows compliance with the requirement.

#### 802.11b

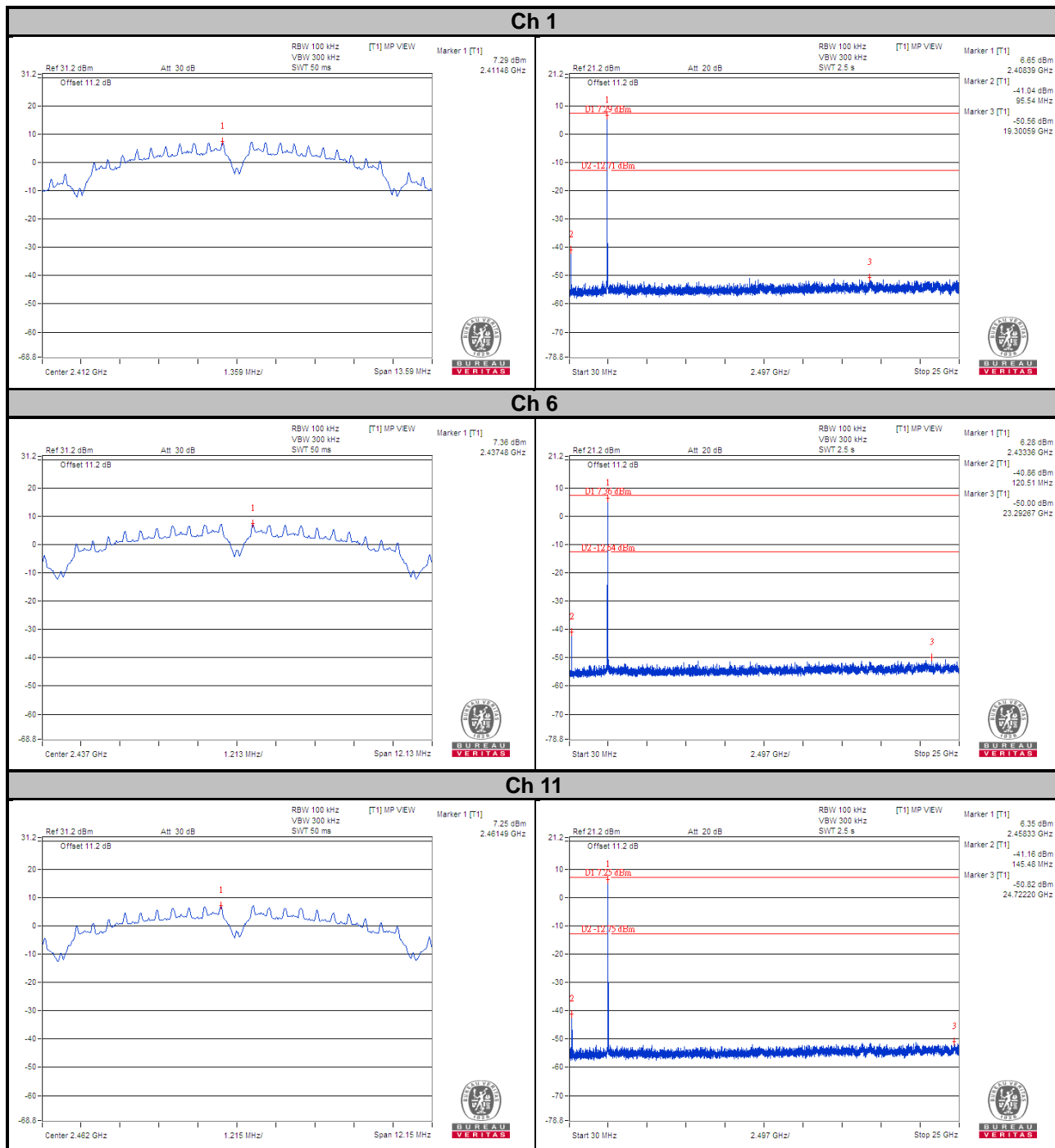

### Ch 12

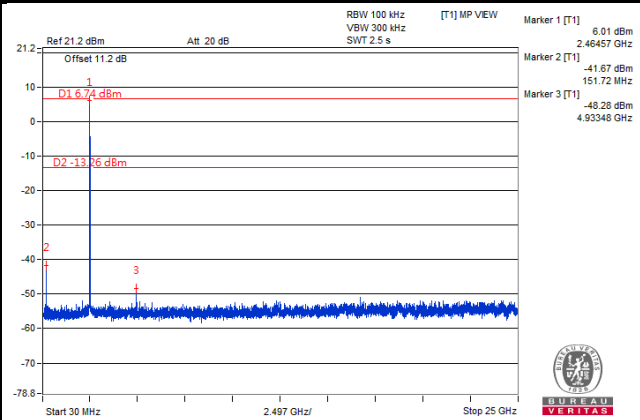
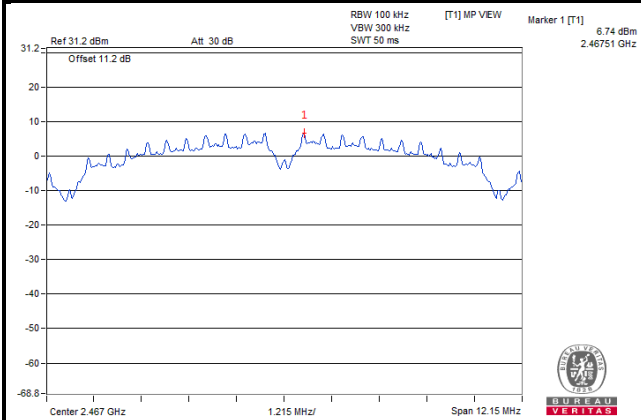

### Ch 13

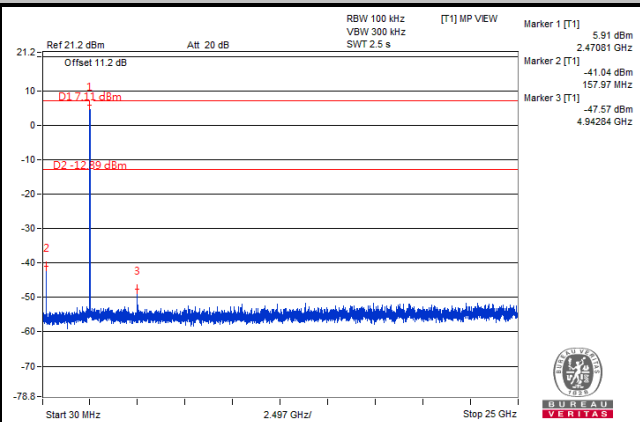
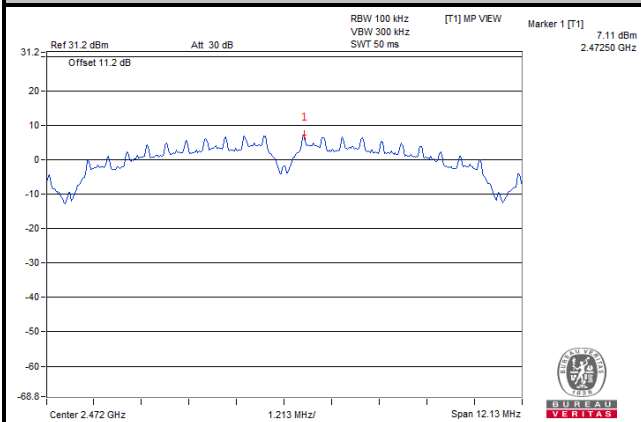

### Ch 1 Band Edge

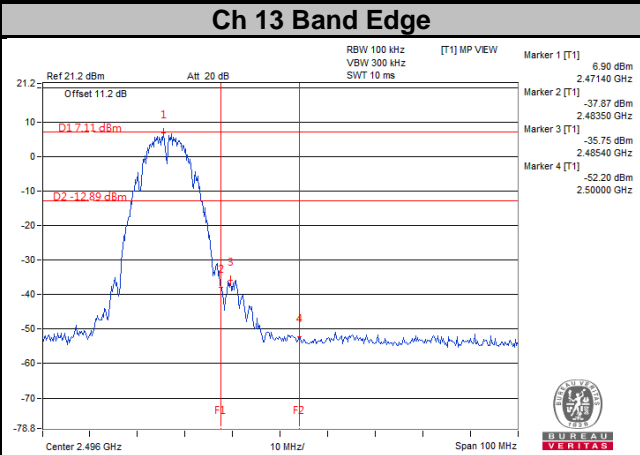
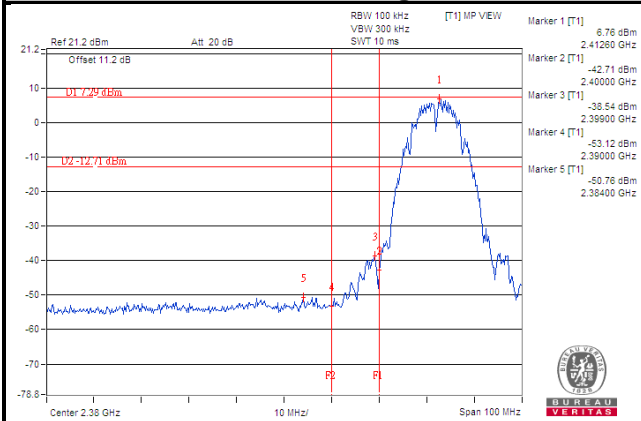

# 802.11g

## Ch 1

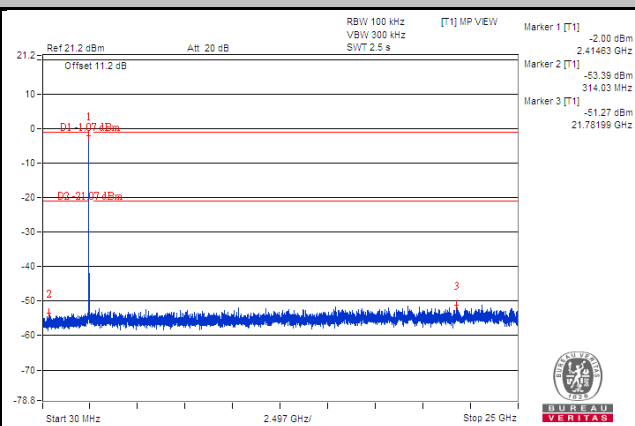
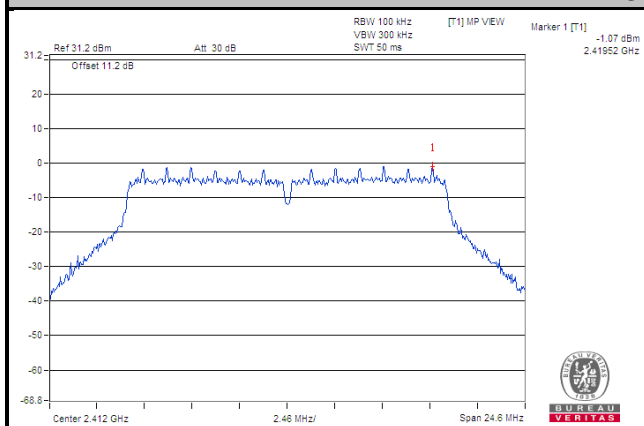

## Ch 6

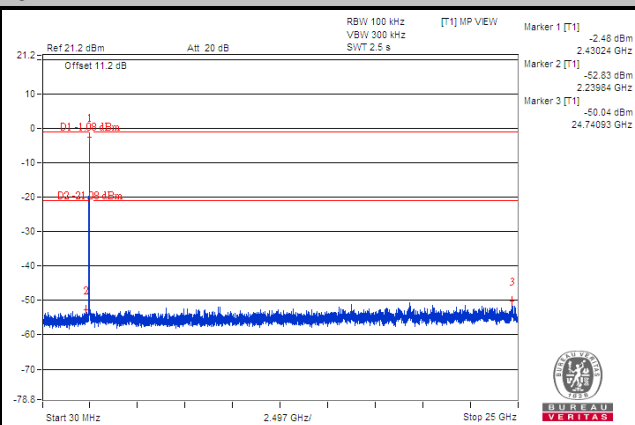
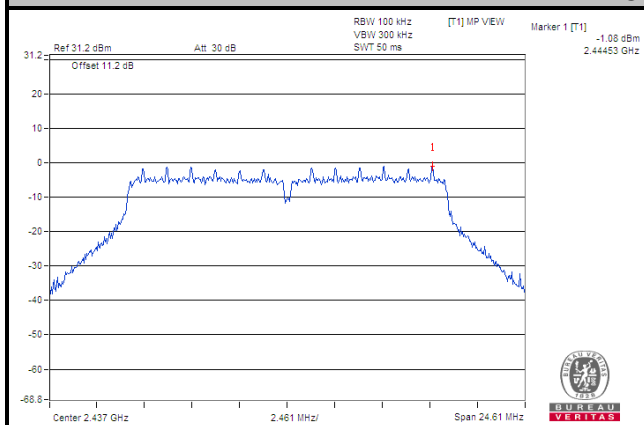

## Ch 11

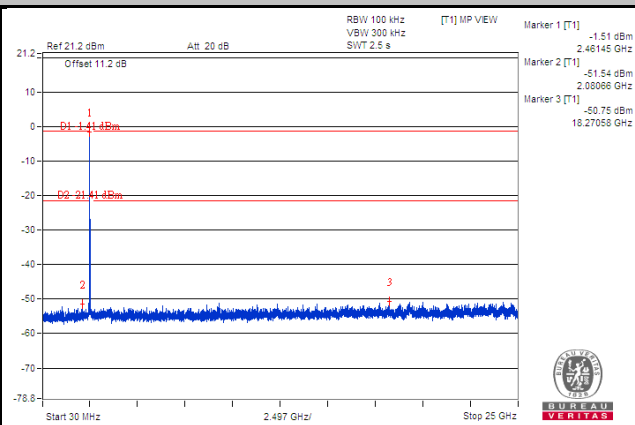
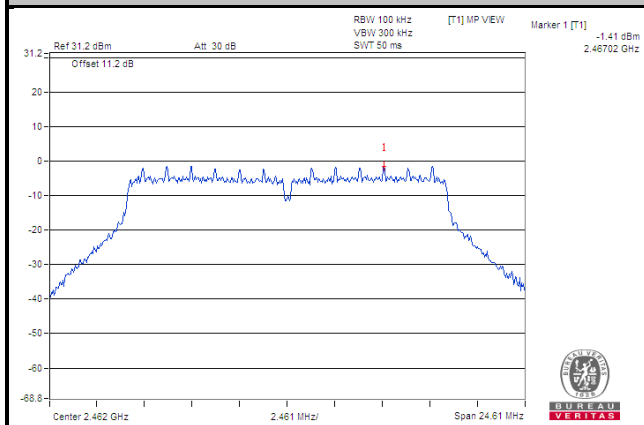

### Ch 12

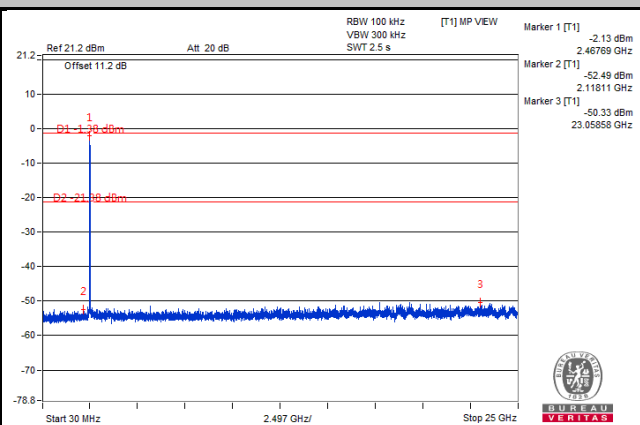
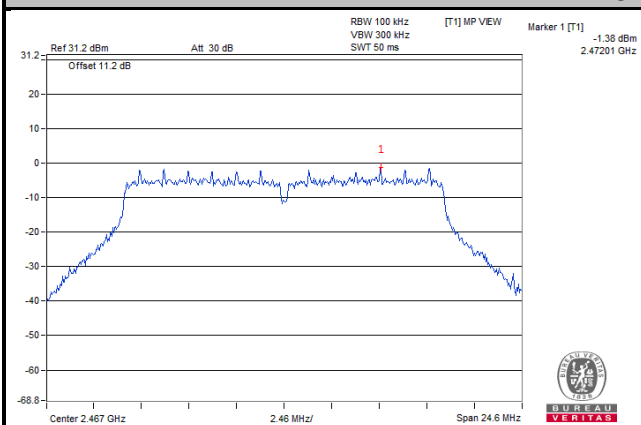

### Ch 13

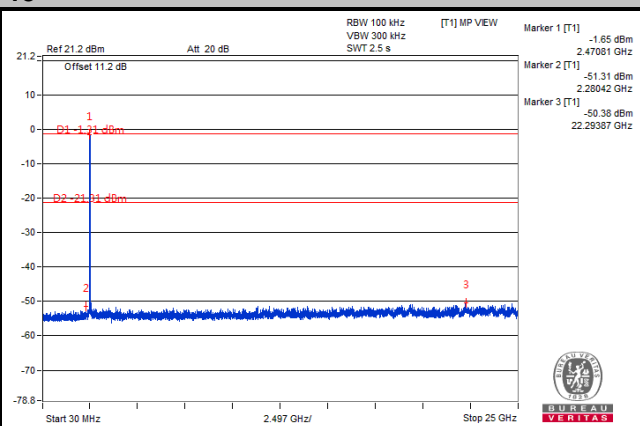
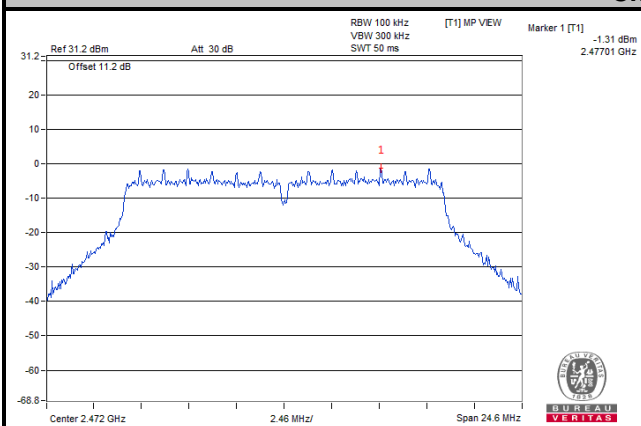

### Ch 1 Band Edge

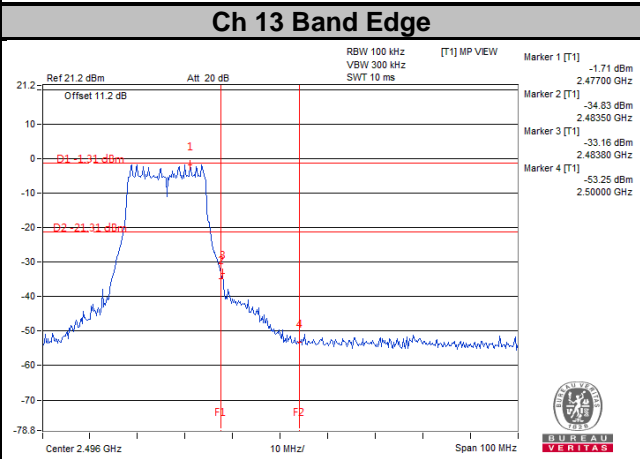
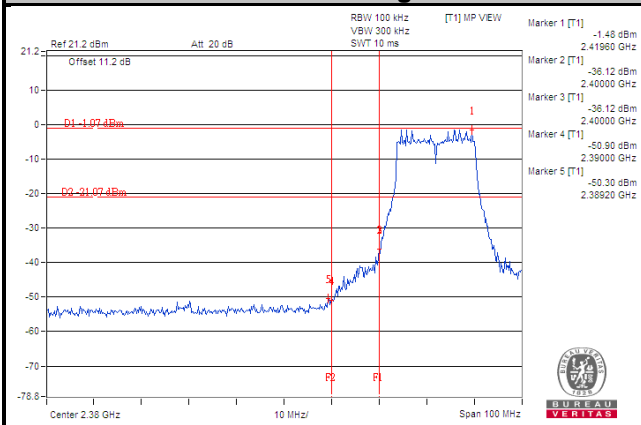



# 802.11n (HT20)

## Ch 1

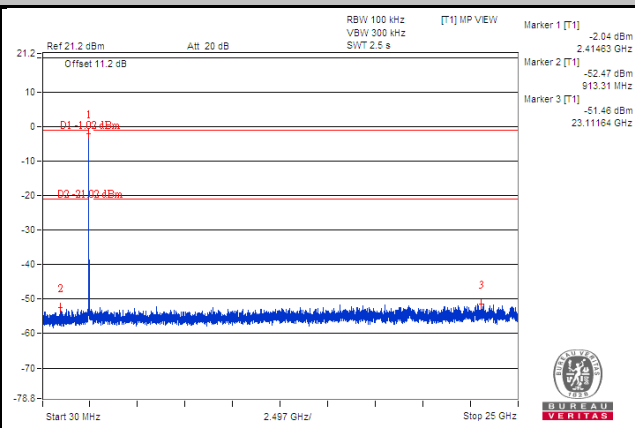
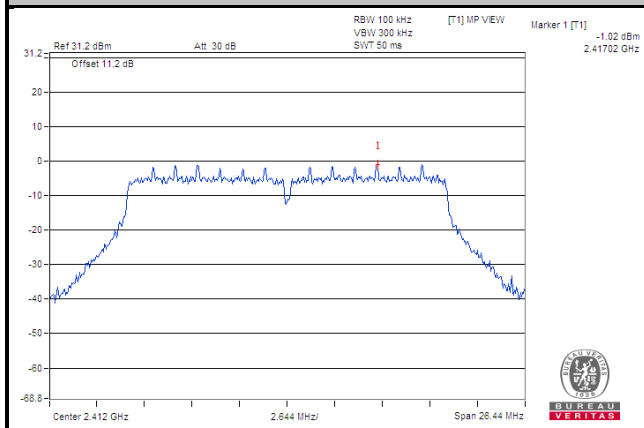

## Ch 6

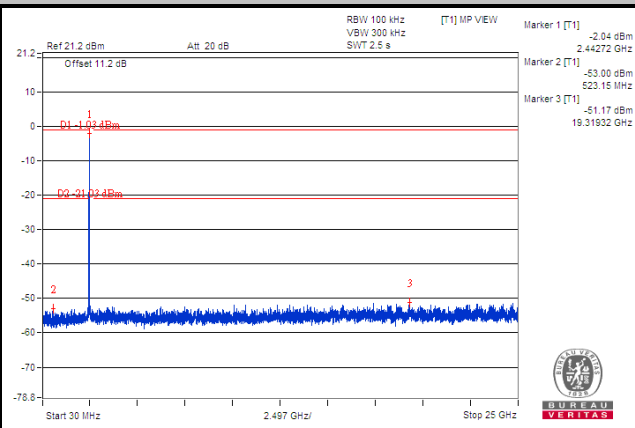
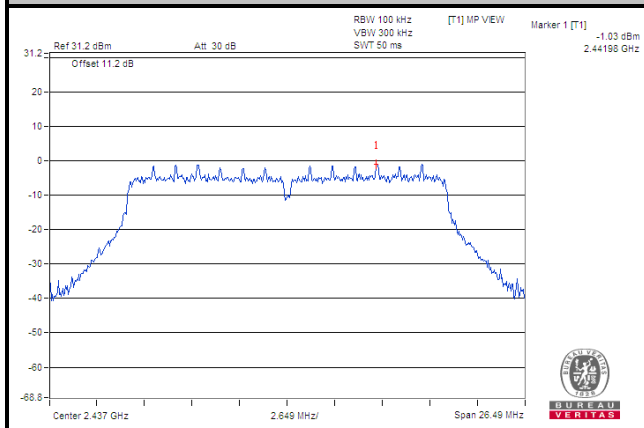

## Ch 11

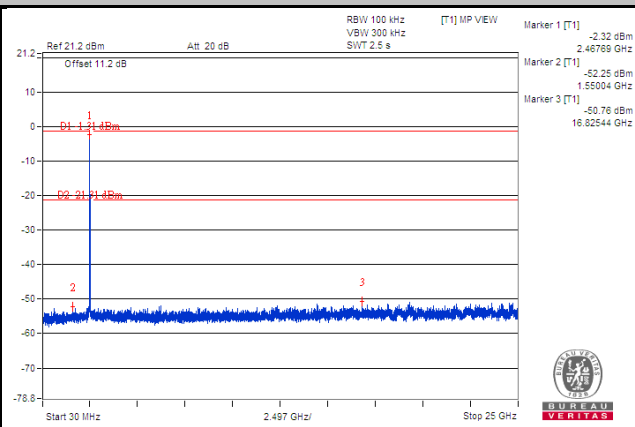
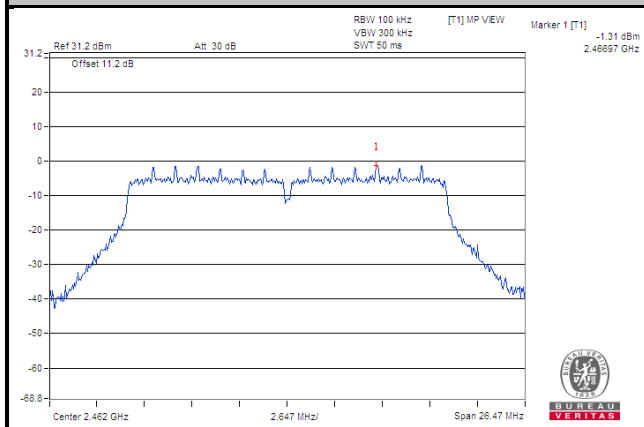

### Ch 12

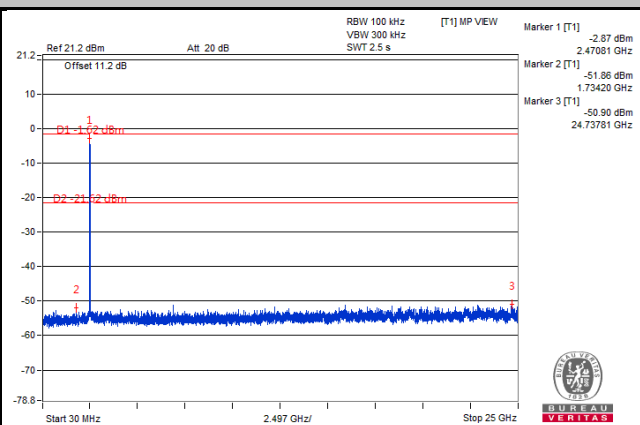
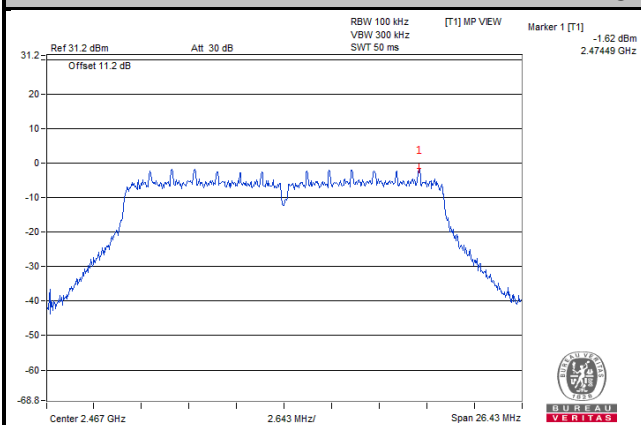

### Ch 13

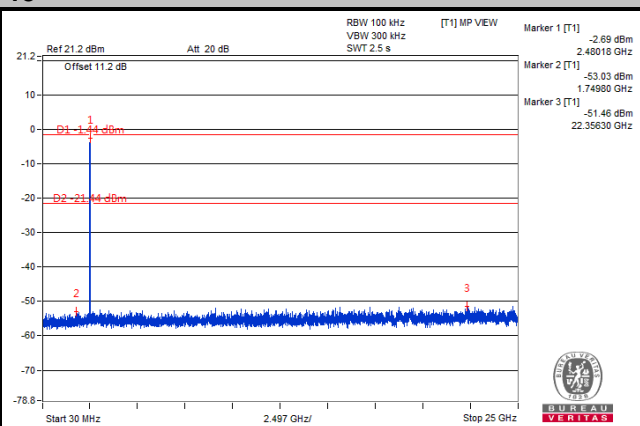
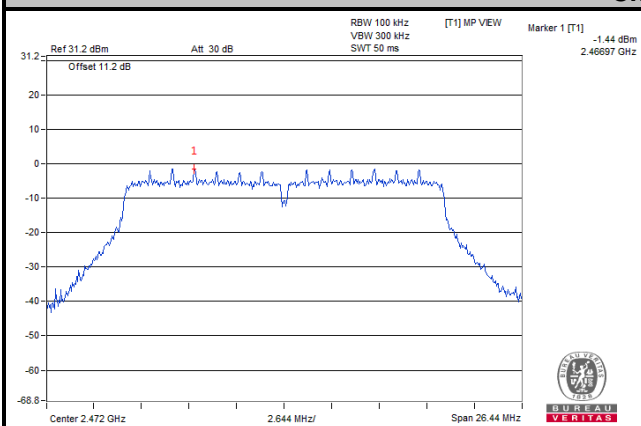

### Ch 1 Band Edge

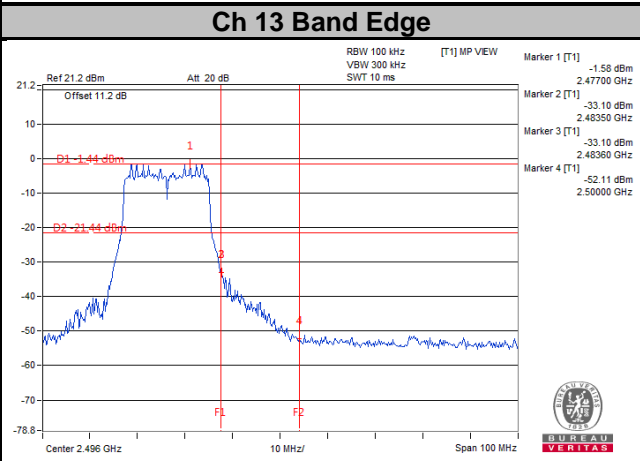
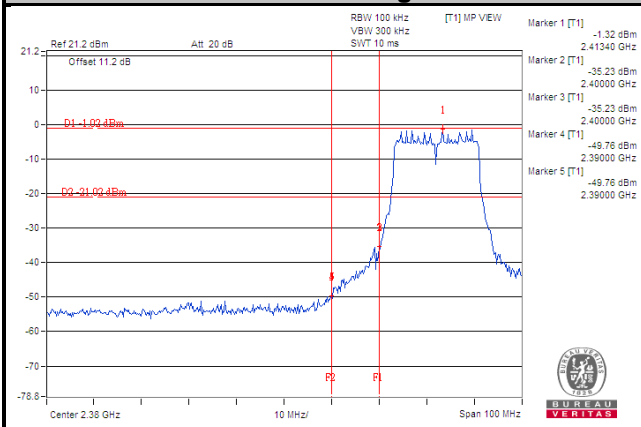

## 5 Pictures of Test Arrangements

Please refer to the attached file (Test Setup Photo).

## Appendix – Information on the Testing Laboratories

We, Bureau Veritas Consumer Products Services (H.K.) Ltd., Taoyuan Branch, were founded in 1988 to provide our best service in EMC, Radio, Telecom and Safety consultation. Our laboratories are FCC recognized accredited test firms and accredited according to ISO/IEC 17025.

If you have any comments, please feel free to contact us at the following:

**Linko EMC/RF Lab**

Tel: 886-2-26052180

Fax: 886-2-26051924

**Hsin Chu EMC/RF/Telecom Lab**

Tel: 886-3-6668565

Fax: 886-3-6668323

**Hwa Ya EMC/RF/Safety**

Tel: 886-3-3183232

Fax: 886-3-3270892

**Email:** [service.adt@tw.bureauveritas.com](mailto:service.adt@tw.bureauveritas.com)

**Web Site:** [www.bureauveritas-adt.com](http://www.bureauveritas-adt.com)

The address and road map of all our labs can be found in our web site also.

--- END ---