

## FCC Test Report

**Report No.:** RF170327C09

**FCC ID:** UK7-DW5A

**Received Date:** Mar. 27, 2017

**Test Date:** Apr. 05, 2017 ~ May 27, 2017

**Issued Date:** Jun. 14, 2017

**Applicant:** Fossil Group, Inc.

**Address:** 901 S. Central Expwy., Richardson, TX 75080 USA

**Issued By:** Bureau Veritas Consumer Products Services (H.K.) Ltd., Taoyuan Branch

**Lab Address:** No. 47-2, 14th Ling, Chia Pau Vil., Lin Kou Dist., New Taipei City, Taiwan  
( R.O.C )

**Test Location (1):** No. 19, Hwa Ya 2nd Rd, Wen Hwa Tsuen, Kwei Shan Hsiang, Taoyuan  
Hsien 333, Taiwan, R.O.C.



This report is for your exclusive use. Any copying or replication of this report to or for any other person or entity, or use of our name or trademark, is permitted only with our prior written permission. This report sets forth our findings solely with respect to the test samples identified herein. The results set forth in this report are not indicative or representative of the quality or characteristics of the lot from which a test sample was taken or any similar or identical product unless specifically and expressly noted. Our report includes all of the tests requested by you and the results thereof based upon the information that you provided to us. You have 60 days from date of issuance of this report to notify us of any material error or omission caused by our negligence, provided, however, that such notice shall be in writing and shall specifically address the issue you wish to raise. A failure to raise such issue within the prescribed time shall constitute your unqualified acceptance of the completeness of this report, the tests conducted and the correctness of the report contents. Unless specific mention, the uncertainty of measurement has been explicitly taken into account to declare the compliance or non-compliance to the specification.

## Table of Contents

<b>Release Control Record</b> .....	<b>4</b>
<b>1 Certificate of Conformity</b> .....	<b>5</b>
<b>2 Summary of Test Results</b> .....	<b>6</b>
2.1 Measurement Uncertainty .....	6
2.2 Modification Record .....	6
<b>3 General Information</b> .....	<b>7</b>
3.1 General Description of EUT .....	7
3.2 Description of Test Modes .....	8
3.2.1 Test Mode Applicability and Tested Channel Detail .....	9
3.3 Description of Support Units .....	11
3.3.1 Configuration of System under Test .....	11
3.4 General Description of Applied Standards .....	12
<b>4 Test Types and Results</b> .....	<b>13</b>
4.1 Radiated Emission and Bandedge Measurement .....	13
4.1.1 Limits of Radiated Emission and Bandedge Measurement .....	13
4.1.2 Test Instruments .....	14
4.1.3 Test Procedures .....	15
4.1.4 Deviation from Test Standard .....	15
4.1.5 Test Set Up .....	16
4.1.6 EUT Operating Conditions .....	16
4.1.7 Test Results .....	17
4.2 Conducted Emission Measurement .....	39
4.2.1 Limits of Conducted Emission Measurement .....	39
4.2.2 Test Instruments .....	39
4.2.3 Test Procedures .....	40
4.2.4 Deviation from Test Standard .....	40
4.2.5 Test Setup .....	40
4.2.6 EUT Operating Condition .....	40
4.2.7 Test Results .....	41
4.3 Number of Hopping Frequency Used .....	47
4.3.1 Limits of Hopping Frequency Used Measurement .....	47
4.3.2 Test Setup .....	47
4.3.3 Test Instruments .....	47
4.3.4 Test Procedure .....	47
4.3.5 Deviation from Test Standard .....	47
4.3.6 Test Results .....	47
4.4 Dwell Time on Each Channel .....	49
4.4.1 Limits of Dwell Time on Each Channel Measurement .....	49
4.4.2 Test Setup .....	49
4.4.3 Test Instruments .....	49
4.4.4 Test Procedures .....	49
4.4.5 Deviation from Test Standard .....	49
4.4.6 Test Results .....	50
4.5 Channel Bandwidth .....	53
4.5.1 Limits of Channel Bandwidth Measurement .....	53
4.5.2 Test Setup .....	53
4.5.3 Test Instruments .....	53
4.5.4 Test Procedure .....	53
4.5.5 Deviation from Test Standard .....	53
4.5.6 EUT Operating Condition .....	53
4.5.7 Test Results .....	54
4.6 Hopping Channel Separation .....	55
4.6.1 Limits of Hopping Channel Separation Measurement .....	55

4.6.2	Test Setup .....	55
4.6.3	Test Instruments .....	55
4.6.4	Test Procedure .....	55
4.6.5	Deviation from Test Standard .....	55
4.6.6	Test Results .....	56
4.7	Maximum Output Power .....	57
4.7.1	Limits of Maximum Output Power Measurement .....	57
4.7.2	Test Setup .....	57
4.7.3	Test Instruments .....	57
4.7.4	Test Procedure .....	57
4.7.5	Deviation from Test Standard .....	57
4.7.6	EUT Operating Condition .....	57
4.7.7	Test Results .....	58
4.8	Conducted Out of Band Emission Measurement .....	59
4.8.1	Limits Of Conducted Out Of Band Emission Measurement .....	59
4.8.2	Test Instruments .....	59
4.8.3	Test Procedure .....	59
4.8.4	Deviation from Test Standard .....	59
4.8.5	EUT Operating Condition .....	59
4.8.6	Test Results .....	59
<b>5</b>	<b>Pictures of Test Arrangements.....</b>	<b>66</b>
	<b>Appendix – Information on the Testing Laboratories .....</b>	<b>67</b>

### Release Control Record

Issue No.	Description	Date Issued
RF170327C09	Original Release	Jun. 14, 2017

## 1 Certificate of Conformity

**Product:** Smart Watch

**Sample Status:** Production Unit

**Applicant:** Fossil Group, Inc.

**Test Date:** Apr. 05, 2017 ~ May 27, 2017

**Standards:** 47 CFR FCC Part 15, Subpart C (Section 15.247)  
ANSI C63.10:2013

The above equipment has been tested by **Bureau Veritas Consumer Products Services (H.K.) Ltd., Taoyuan Branch**, and found compliance with the requirement of the above standards. The test record, data evaluation & Equipment Under Test (EUT) configurations represented herein are true and accurate accounts of the measurements of the sample's EMC characteristics under the conditions specified in this report.

**Prepared by :**  \_\_\_\_\_, **Date:** \_\_\_\_\_ Jun. 14, 2017  
Ivonne Wu / Supervisor

**Approved by :**  \_\_\_\_\_, **Date:** \_\_\_\_\_ Jun. 14, 2017  
David Huang / Project Engineer

## 2 Summary of Test Results

47 CFR FCC Part 15, Subpart C (Section 15.247)			
FCC Clause	Test Item	Result	Remarks
15.207	AC Power Conducted Emission	Pass	Meet the requirement of limit. Minimum passing margin is -0.80 dB at 1.85800 MHz.
15.247(a)(1)(iii)	Number of Hopping Frequency Used	Pass	Meet the requirement of limit.
15.247(a)(1)(iii)	Dwell Time on Each Channel	Pass	Meet the requirement of limit.
15.247(a)(1)	1. Hopping Channel Separation 2. Spectrum Bandwidth of a Frequency Hopping Sequence Spread Spectrum System	Pass	Meet the requirement of limit.
15.247(b)	Maximum Peak Output Power	Pass	Meet the requirement of limit.
15.205 & 209	Radiated Emissions	Pass	Meet the requirement of limit. Minimum passing margin is -2.41 dB at 32.91 MHz.
15.247(d)	Band Edge Measurement	Pass	Meet the requirement of limit.
15.247(d)	Antenna Port Emission	Pass	Meet the requirement of limit.
15.203	Antenna Requirement	Pass	No antenna connector is used.

**Note:** If The Frequency Hopping System operating in 2400-2483.5 MHz band and the output power less than 125 mW. The hopping channel carrier frequencies separated by a minimum of 25 kHz or two-thirds of the 20 dB bandwidth of hopping channel whichever is greater.

### 2.1 Measurement Uncertainty

Where relevant, the following measurement uncertainty levels have been estimated for tests performed on the EUT:

The listed uncertainties are the worst case uncertainty for the entire range of measurement. Please note that the uncertainty values are provided for informational purposes only and are not used in determining the PASS/FAIL results.

Measurement	Frequency	Expanded Uncertainty (k=2) (±)
Conducted Emissions at mains ports	150 kHz ~ 30 MHz	2.44 dB
Radiated Emissions up to 1 GHz	30 MHz ~ 200 MHz	2.93 dB
	200 MHz ~ 1000 MHz	2.95 dB
Radiated Emissions above 1 GHz	1 GHz ~ 18 GHz	2.26 dB
	18 GHz ~ 40 GHz	1.94 dB

### 2.2 Modification Record

There were no modifications required for compliance.

### 3 General Information

#### 3.1 General Description of EUT

<b>Product</b>	Smart Watch
<b>Status of EUT</b>	Production Unit
<b>Power Supply Rating</b>	5.0 Vdc (from wireless charger) 3.8 Vdc (from battery)
<b>Modulation Type</b>	GFSK, $\pi/4$ -DQPSK, 8DPSK
<b>Transfer Rate</b>	1/2/3 Mbps
<b>Operating Frequency</b>	2402 ~ 2480 MHz
<b>Number of Channel</b>	79
<b>Output Power</b>	18.155 mW
<b>Antenna Type</b>	Loop antenna
<b>Antenna Connector</b>	N/A
<b>Accessory Device</b>	Refer to Note as below
<b>Data Cable Supplied</b>	Refer to Note as below

Note:

- There're 3 configurations for the EUT listed as below.

Sample	Antenna Gain (dBi)	Difference
A	-4.85	The samples are different in the appearance and antenna only.
B	-3.75	
C	-2.55	

- The EUT's accessories list refers to Ext. Pho.

### 3.2 Description of Test Modes

79 channels are provided to this EUT:

Channel	Freq. (MHz)	Channel	Freq. (MHz)	Channel	Freq. (MHz)	Channel	Freq. (MHz)
0	2402	20	2422	40	2442	60	2462
1	2403	21	2423	41	2443	61	2463
2	2404	22	2424	42	2444	62	2464
3	2405	23	2425	43	2445	63	2465
4	2406	24	2426	44	2446	64	2466
5	2407	25	2427	45	2447	65	2467
6	2408	26	2428	46	2448	66	2468
7	2409	27	2429	47	2449	67	2469
8	2410	28	2430	48	2450	68	2470
9	2411	29	2431	49	2451	69	2471
10	2412	30	2432	50	2452	70	2472
11	2413	31	2433	51	2453	71	2473
12	2414	32	2434	52	2454	72	2474
13	2415	33	2435	53	2455	73	2475
14	2416	34	2436	54	2456	74	2476
15	2417	35	2437	55	2457	75	2477
16	2418	36	2438	56	2458	76	2478
17	2419	37	2439	57	2459	77	2479
18	2420	38	2440	58	2460	78	2480
19	2421	39	2441	59	2461		



### 3.2.1 Test Mode Applicability and Tested Channel Detail

EUT Configure Mode	Applicable To				Description
	RE $\geq$ 1G	RE $<$ 1G	PLC	APCM	
A	√	√	√	√	Sample C
B	√	√	√	-	Sample B
C	√	√	√	-	Sample A

Where **RE $\geq$ 1G**: Radiated Emission above 1 GHz      **RE $<$ 1G**: Radiated Emission below 1 GHz  
**PLC**: Power Line Conducted Emission      **APCM**: Antenna Port Conducted Measurement

**Note:**

1. For Radiated emission test, pre-tested GFSK,  $\pi/4$ -DQPSK, 8DPSK modulation type and found 8DPSK was the worse, therefore chosen for the final test and presented in the test report.
2. The EUT had been pre-tested on the positioned of each 3 axis. The worst case was found when positioned on **Z-plane**.
3. "-" means no effect.

**Radiated Emission Test (Above 1 GHz):**

- Pre-Scan has been conducted to determine the worst-case mode from all possible combinations between available modulations, data rates and antenna ports (if EUT with antenna diversity architecture).
- Following channel(s) was (were) selected for the final test as listed below.

EUT Configure Mode	Available Channel	Tested Channel	Modulation Technology	Modulation Type	Packet Type
A	0 to 78	0, 39, 78	FHSS	8DPSK	DH5
B, C	0 to 78	78	FHSS	8DPSK	DH5

**Radiated Emission Test (Below 1 GHz):**

- Pre-Scan has been conducted to determine the worst-case mode from all possible combinations between available modulations, data rates and antenna ports (if EUT with antenna diversity architecture).
- Following channel(s) was (were) selected for the final test as listed below.

EUT Configure Mode	Available Channel	Tested Channel	Modulation Technology	Modulation Type	Packet Type
A, B, C	0 to 78	78	FHSS	8DPSK	DH5

**Power Line Conducted Emission Test:**

- Pre-Scan has been conducted to determine the worst-case mode from all possible combinations between available modulations, data rates and antenna ports (if EUT with antenna diversity architecture).
- Following channel(s) was (were) selected for the final test as listed below.

EUT Configure Mode	Available Channel	Tested Channel	Modulation Technology	Modulation Type	Packet Type
A, B, C	0 to 78	78	FHSS	8DPSK	DH5

**Antenna Port Conducted Measurement:**

- This item includes all test value of each mode, but only includes spectrum plot of worst value of each mode.
- Pre-Scan has been conducted to determine the worst-case mode from all possible combinations between available modulations, data rates and antenna ports (if EUT with antenna diversity architecture).
- Following channel(s) was (were) selected for the final test as listed below.

EUT Configure Mode	Available Channel	Tested Channel	Modulation Technology	Modulation Type	Packet Type
A	0 to 78	0, 39, 78	FHSS	GFSK	DH5
	0 to 78	0, 39, 78	FHSS	$\pi/4$ -DQPSK	DH5
	0 to 78	0, 39, 78	FHSS	8DPSK	DH5

**Test Condition:**

Applicable To	Environmental Conditions	Input Power	Tested by
RE $\geq$ 1G	25 deg. C, 65 % RH	5 Vdc	Getaz Yang
RE $<$ 1G	25 deg. C, 65 % RH	5 Vdc	Getaz Yang
PLC	25 deg. C, 65 % RH	5 Vdc	Getaz Yang
APCM	25 deg. C, 65 % RH	3.8 Vdc	Wayne Lin

### 3.3 Description of Support Units

The EUT has been tested as an independent unit together with other necessary accessories or support units. The following support units or accessories were used to form a representative test configuration during the tests.

No.	Product	Brand	Model No.	Serial No.	FCC ID
1.	Adapter	XIAOMI	MDY-08-EF	N/A	N/A

No.	Signal Cable Description Of The Above Support Units
1.	N/A

Note:

1. All power cords of the above support units are non-shielded (1.8m).

#### 3.3.1 Configuration of System under Test

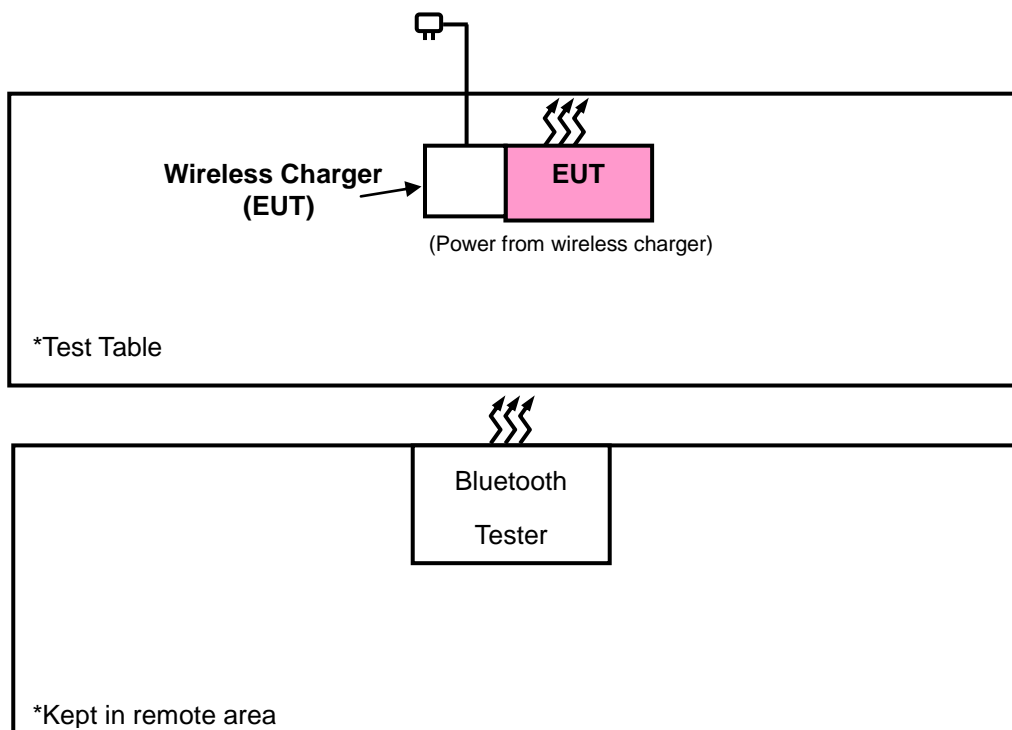

### 3.4 General Description of Applied Standards

The EUT is a RF Product. According to the specifications of the manufacturer, it must comply with the requirements of the following standards:

**FCC Part 15, Subpart C (15.247)**

**FCC Public Notice DA 00-705**

ANSI C63.10-2013

All test items have been performed and recorded as per the above standards.

**Note:** The EUT has been verified to comply with the requirements of FCC Part 15, Subpart B, Class B (Verification). The test report has been issued separately.

## 4 Test Types and Results

### 4.1 Radiated Emission and Bandedge Measurement

#### 4.1.1 Limits of Radiated Emission and Bandedge Measurement

Radiated emissions which fall in the restricted bands must comply with the radiated emission limits specified as below table. Other emissions shall be at least 20 dB below the highest level of the desired power:

Frequencies (MHz)	Field Strength (microvolts/meter)	Measurement Distance (meters)
0.009 ~ 0.490	2400/F (kHz)	300
0.490 ~ 1.705	24000/F (kHz)	30
1.705 ~ 30.0	30	30
30 ~ 88	100	3
88 ~ 216	150	3
216 ~ 960	200	3
Above 960	500	3

**Note:**

1. The lower limit shall apply at the transition frequencies.
2. Emission level (dBuV/m) = 20 log Emission level (uV/m).
3. For frequencies above 1000 MHz, the field strength limits are based on average detector, however, the peak field strength of any emission shall not exceed the maximum permitted average limits, specified above by more than 20 dB under any condition of modulation.

#### 4.1.2 Test Instruments

Description & Manufacturer	Model No.	Serial No.	Date of Calibration	Due Date of Calibration
Test Receiver Agilent	N9038A	MY51210203	Feb. 17, 2017	Feb. 16, 2018
Spectrum Analyzer Agilent	N9010A	MY52220314	Dec. 16, 2016	Dec. 15, 2017
Spectrum Analyzer ROHDE & SCHWARZ	FSU43	101261	Dec. 13, 2016	Dec. 12, 2017
BILOG Antenna SCHWARZBECK	VULB9168	9168-472	Dec. 26, 2016	Dec. 27, 2017
HORN Antenna SCHWARZBECK	BBHA 9120 D	9120D-969	Dec. 12, 2016	Dec. 13, 2017
HORN Antenna SCHWARZBECK	BBHA 9170	9170-480	Dec. 14, 2016	Dec. 13, 2017
Fixed Attenuator Mini-Circuits	BW-N10W5+	NA	Jul. 08, 2016	Jul. 07, 2017
Loop Antenna	EM-6879	269	Aug. 11, 2016	Aug. 10, 2017
Bluetooth Tester	CBT	100946	Jul. 29, 2016	Jul. 28, 2018
Preamplifier EMCI	EMC 012645	980115	Oct. 21, 2016	Oct. 20, 2017
Preamplifier EMCI	EMC 184045	980116	Oct. 21, 2016	Oct. 20, 2017
Preamplifier EMCI	EMC 330H	980112	Oct. 21, 2016	Oct. 20, 2017
Power Meter Anritsu	ML2495A	1232002	Sep. 08, 2016	Sep. 07, 2017
Power Sensor Anritsu	MA2411B	1207325	Sep. 08, 2016	Sep. 07, 2017
RF signal cable HUBER+SUHNNER	SUCOFLEX 104	309219/4 2950114	Oct. 21, 2016	Oct. 20, 2017
RF signal cable HUBER+SUHNNER	SUCOFLEX 104	250130/4	Oct. 21, 2016	Oct. 20, 2017
RF Coaxial Cable Worken	8D-FB	Cable-Ch10-01	Oct. 21, 2016	Oct. 20, 2017
Software BV ADT	E3 6.120103	NA	NA	NA
Antenna Tower MF	MFA-440H	NA	NA	NA
Turn Table MF	MFT-201SS	NA	NA	NA
Antenna Tower & Turn Table Controller MF	MF-7802	NA	NA	NA

- Note: 1. The calibration interval of the above test instruments is 12 months and the calibrations are traceable to NML/ROC and NIST/USA.
2. The test was performed in HwaYa Chamber 10.
3. The horn antenna and preamplifier (model: EMC 184045) are used only for the measurement of emission frequency above 1 GHz if tested.
4. The FCC Site Registration No. is 690701.
5. The IC Site Registration No. is IC7450F-10.

#### 4.1.3 Test Procedures

- a. The EUT was placed on the top of a rotating table 0.8 meters (for below 1 GHz) / 1.5 meters (for above 1 GHz) above the ground at 3 meter chamber room for test. The table was rotated 360 degrees to determine the position of the highest radiation.
- b. The EUT was set 3 meters away from the interference-receiving antenna, which was mounted on the top of a variable-height antenna tower.
- c. The height of antenna is varied from one meter to four meters above the ground to determine the maximum value of the field strength. Both horizontal and vertical polarizations of the antenna are set to make the measurement.
- d. For each suspected emission, the EUT was arranged to its worst case and then the antenna was tuned to heights from 1 meter to 4 meters and the rotatable table was turned from 0 degrees to 360 degrees to find the maximum reading.
- e. The test-receiver system was set to quasi-peak detect function and specified bandwidth with maximum hold mode when the test frequency is below 1 GHz.
- f. The test-receiver system was set to peak and average detected function and specified bandwidth with maximum hold mode when the test frequency is above 1 GHz. If the peak reading value also meets average limit, measurement with the average detector is unnecessary.

**Note:**

1. The resolution bandwidth and video bandwidth of test receiver/spectrum analyzer is 120 kHz & 360 kHz for Quasi-peak detection (QP) at frequency below 1 GHz.
2. The resolution bandwidth of test receiver/spectrum analyzer is 1 MHz and the video bandwidth is 3 MHz for Peak detection (PK) at frequency above 1 GHz.
3. The resolution bandwidth of test receiver/spectrum analyzer is 1 MHz and the video bandwidth is 1/T for Average (Duty cycle < 98 %) detection at frequency above 1 GHz.  
Please see page 52 for plotted duty.
4. The resolution bandwidth of test receiver/spectrum analyzer is 1 MHz and the video bandwidth is 10 Hz (Duty cycle  $\geq$  98 %) for Average detection (AV) at frequency above 1 GHz.
5. All modes of operation were investigated and the worst-case emissions are reported.

#### 4.1.4 Deviation from Test Standard

No deviation.

#### 4.1.5 Test Set Up

##### <Frequency Range below 1 GHz>

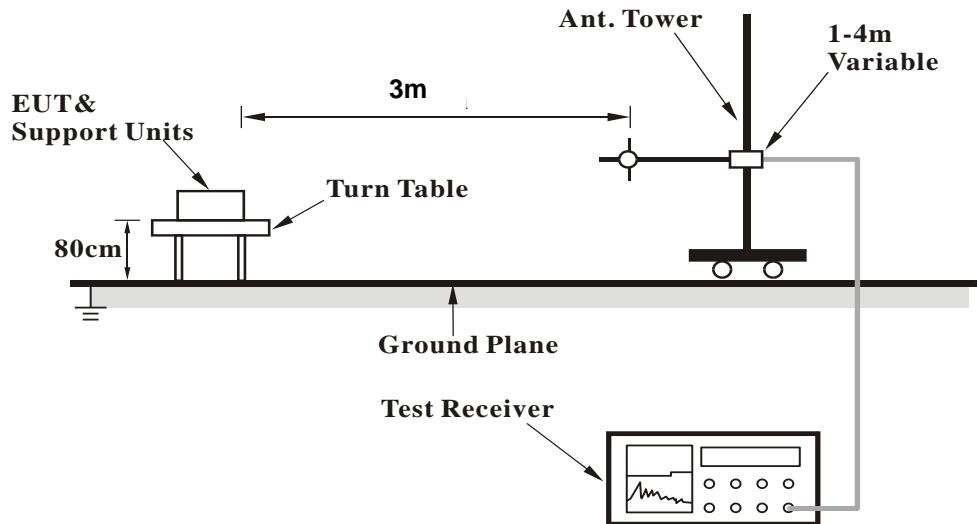

##### <Frequency Range above 1 GHz>

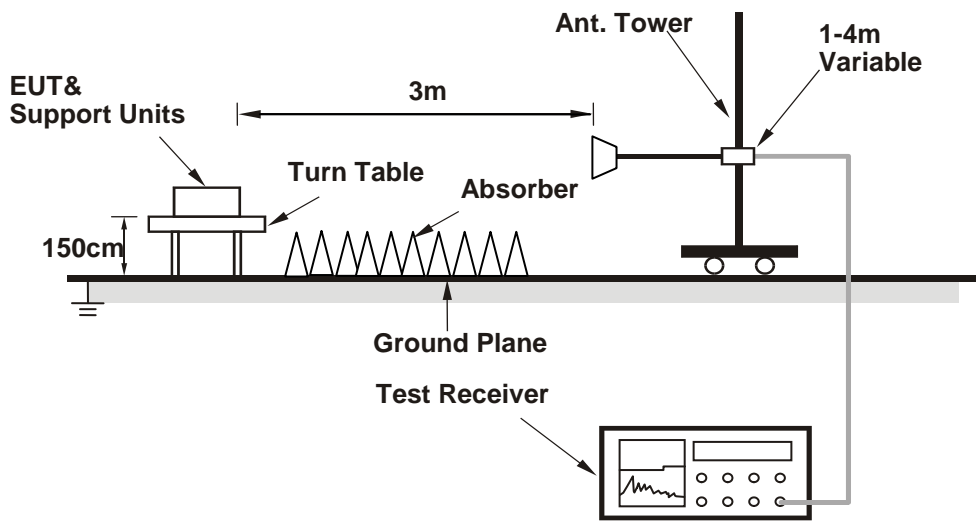

For the actual test configuration, please refer to the attached file (Test Setup Photo).

#### 4.1.6 EUT Operating Conditions

Set the EUT under transmission condition continuously at specific channel frequency.



4.1.7 Test Results

ABOVE 1 GHz DATA :

8DPSK

Mode A

EUT Test Condition		Measurement Detail	
Channel	Channel 0	Frequency Range	1 GHz ~ 25 GHz
Input Power	120 Vac, 60 Hz	Detector Function	Peak (PK) Average (AV)
Environmental Conditions	25 deg. C, 65 % RH	Tested By	Getaz Yang

Horizontal

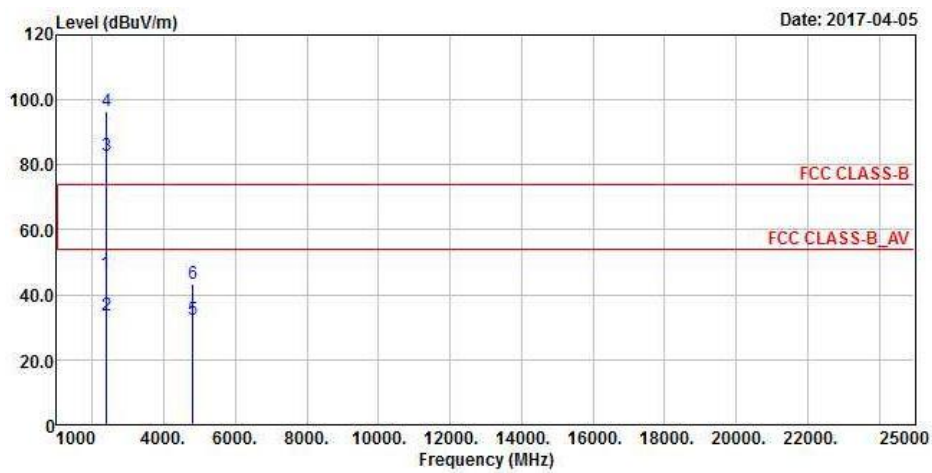

Vertical

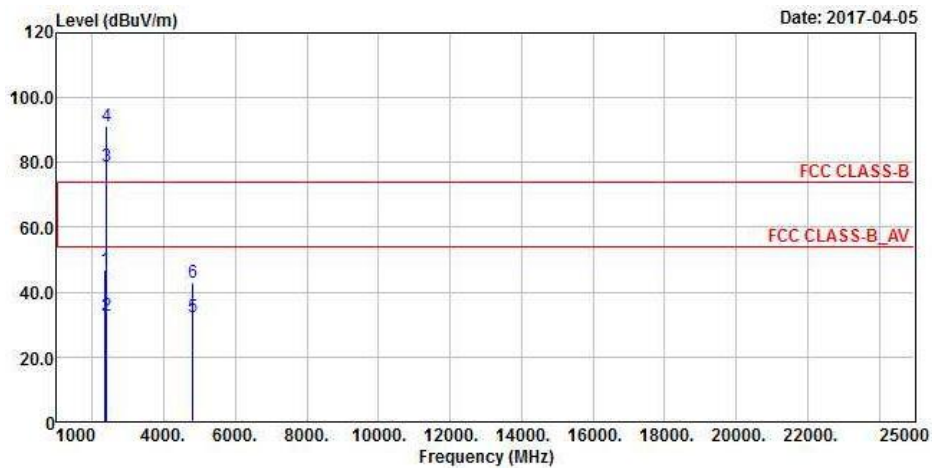

**Antenna Polarity & Test Distance: Horizontal at 3 m**

Frequency (MHz)	Emission Level (dBuV/m)	Read Level (dBuV)	Limit (dBuV/m)	Margin (dB)	Antenna Factor (dB/m)	Cable Loss (dB)	Preamp Factor (dB)	Antenna Height (cm)	Table Angle (Degree)	Remark
2368.32	46.56	53.18	74	-27.44	26.81	4.07	37.5	209	197	Peak
2388.48	33.45	39.96	54	-20.55	26.91	4.08	37.5	209	197	Average
2402	82.87	89.39			26.91	4.09	37.52	209	197	Average
2402	96.49	103.01			26.91	4.09	37.52	209	197	Peak
4804	32.45	47.79	54	-21.55	30.97	6.79	53.1	121	136	Average
4804	43.4	58.74	74	-30.6	30.97	6.79	53.1	121	136	Peak

**Antenna Polarity & Test Distance: Vertical at 3 m**

Frequency (MHz)	Emission Level (dBuV/m)	Read Level (dBuV)	Limit (dBuV/m)	Margin (dB)	Antenna Factor (dB/m)	Cable Loss (dB)	Preamp Factor (dB)	Antenna Height (cm)	Table Angle (Degree)	Remark
2347.14	47.1	53.77	74	-26.9	26.77	4.05	37.49	208	357	Peak
2388.13	32.89	39.4	54	-21.11	26.91	4.08	37.5	208	357	Average
2402	78.92	85.44			26.91	4.09	37.52	208	357	Average
2402	91.16	97.68			26.91	4.09	37.52	208	357	Peak
4804	32.15	47.49	54	-21.85	30.97	6.79	53.1	115	276	Average
4804	42.87	58.21	74	-31.13	30.97	6.79	53.1	115	276	Peak

Remarks:

1. Emission Level = Read Level + Antenna Factor + Cable Loss - Preamp Factor

Margin value = Emission level – Limit value

2. 2402 MHz: Fundamental frequency.

EUT Test Condition		Measurement Detail	
Channel	Channel 39	Frequency Range	1 GHz ~ 25 GHz
Input Power	120 Vac, 60 Hz	Detector Function	Peak (PK) Average (AV)
Environmental Conditions	25 deg. C, 65 % RH	Tested By	Getaz Yang

**Horizontal**

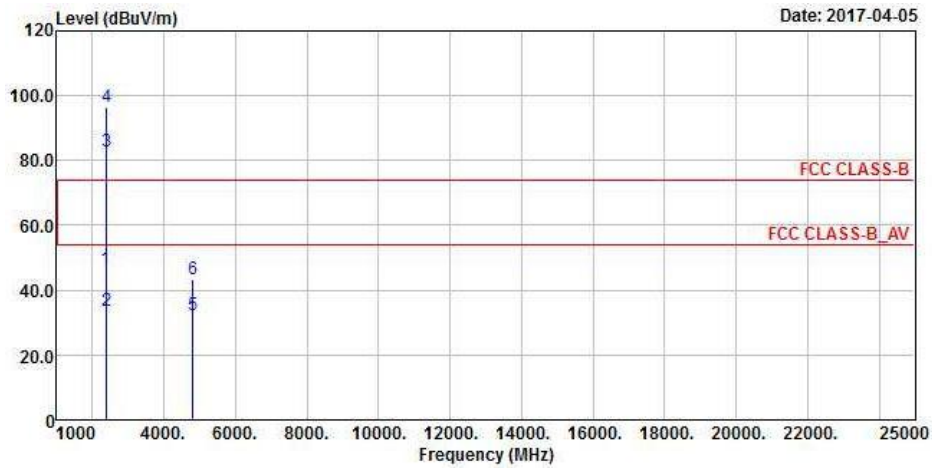

**Vertical**

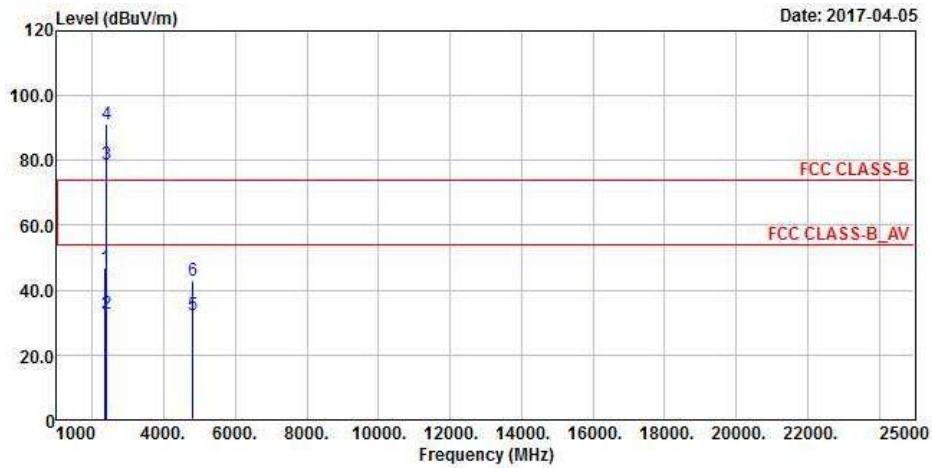

**Antenna Polarity & Test Distance: Horizontal at 3 m**

Frequency (MHz)	Emission Level (dBuV/m)	Read Level (dBuV)	Limit (dBuV/m)	Margin (dB)	Antenna Factor (dB/m)	Cable Loss (dB)	Preamp Factor (dB)	Antenna Height (cm)	Table Angle (Degree)	Remark
2377.23	47.05	53.62	74	-26.95	26.86	4.07	37.5	210	194	Peak
2388.57	32.96	39.47	54	-21.04	26.91	4.08	37.5	210	194	Average
2441	82.94	89.15			27.06	4.12	37.39	210	194	Average
2441	96.41	102.62			27.06	4.12	37.39	210	194	Peak
2498.12	46.94	52.83	74	-27.06	27.2	4.16	37.25	210	194	Peak
2499.16	33.5	39.39	54	-20.5	27.2	4.16	37.25	210	194	Average
4882	32.71	47.85	54	-21.29	31.06	6.85	53.05	128	142	Average
4882	43.17	58.31	74	-30.83	31.06	6.85	53.05	128	142	Peak

**Antenna Polarity & Test Distance: Vertical at 3 m**

Frequency (MHz)	Emission Level (dBuV/m)	Read Level (dBuV)	Limit (dBuV/m)	Margin (dB)	Antenna Factor (dB/m)	Cable Loss (dB)	Preamp Factor (dB)	Antenna Height (cm)	Table Angle (Degree)	Remark
2384.16	46.47	53.03	74	-27.53	26.86	4.08	37.5	210	353	Peak
2386.5	33.02	39.53	54	-20.98	26.91	4.08	37.5	210	353	Average
2441	78.83	85.04			27.06	4.12	37.39	210	353	Average
2441	91.36	97.57			27.06	4.12	37.39	210	353	Peak
2488.68	47.18	53.14	74	-26.82	27.2	4.16	37.32	210	353	Peak
2497.76	33.47	39.36	54	-20.53	27.2	4.16	37.25	210	353	Average
4882	32.31	47.45	54	-21.69	31.06	6.85	53.05	106	281	Average
4882	42.93	58.07	74	-31.07	31.06	6.85	53.05	106	281	Peak

Remarks:

- Emission Level = Read Level + Antenna Factor + Cable Loss - Preamp Factor  
Margin value = Emission level – Limit value
- 2441 MHz: Fundamental frequency.

EUT Test Condition		Measurement Detail	
Channel	Channel 78	Frequency Range	1 GHz ~ 25 GHz
Input Power	120 Vac, 60 Hz	Detector Function	Peak (PK) Average (AV)
Environmental Conditions	25 deg. C, 65 % RH	Tested By	Getaz Yang

### Horizontal

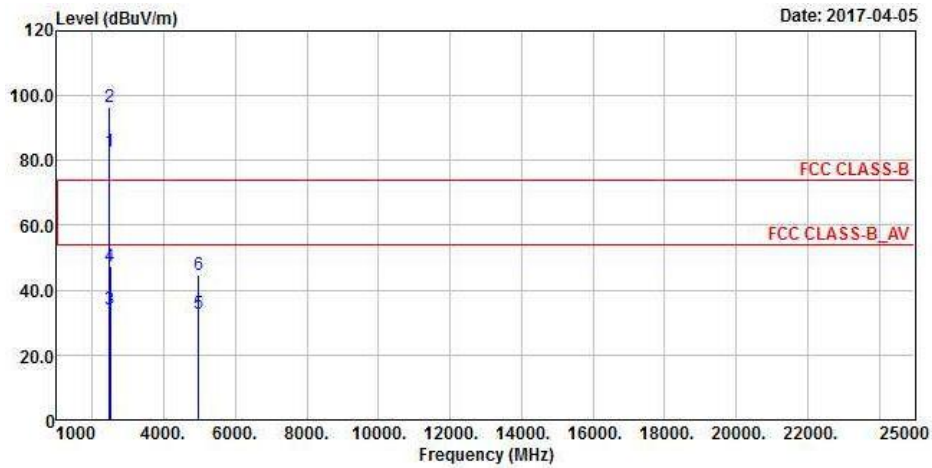

### Vertical

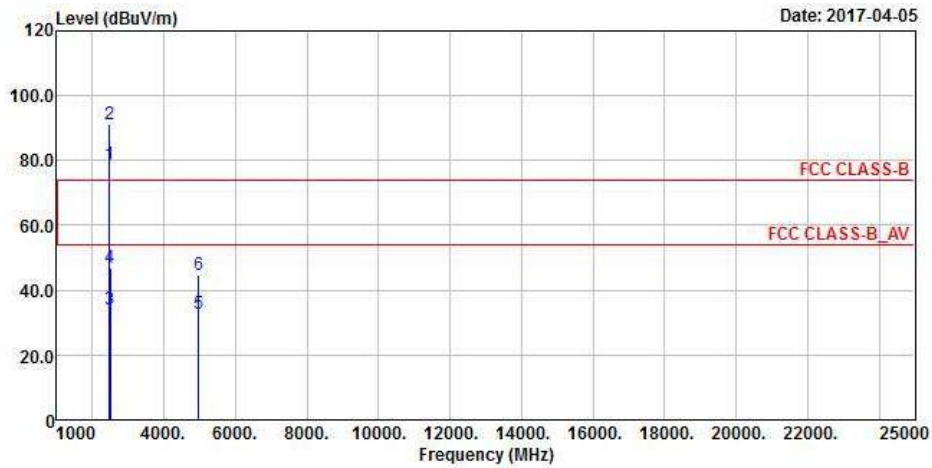

**Band Edge  
Peak  
Horizontal**

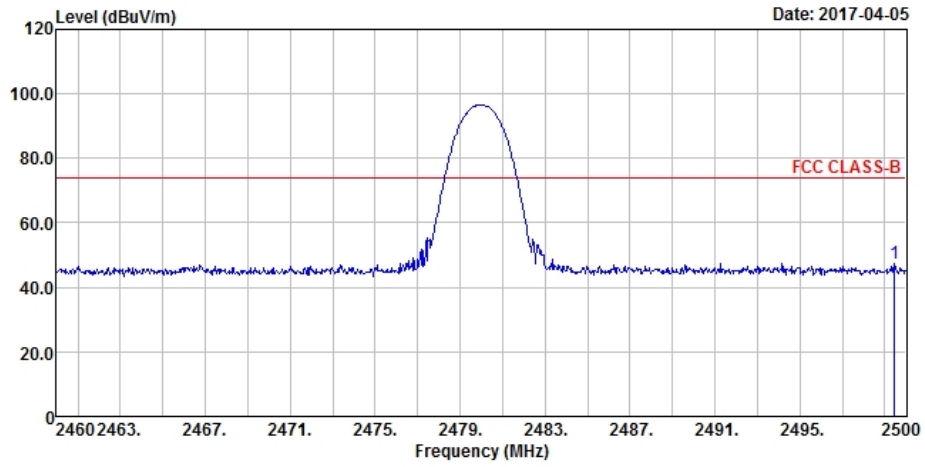

**Vertical**

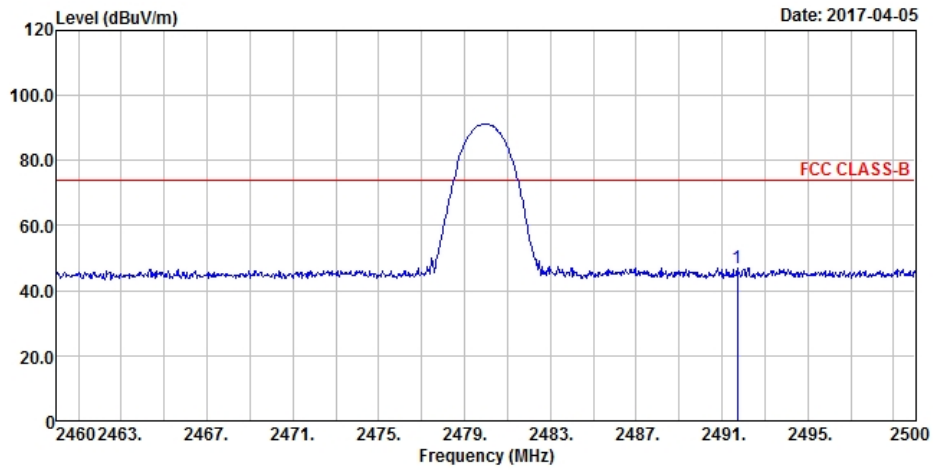

### Average Horizontal

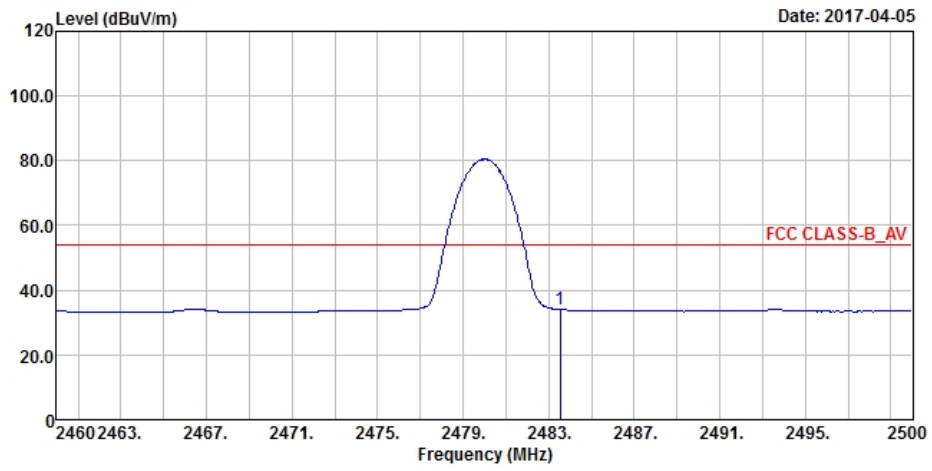

### Vertical

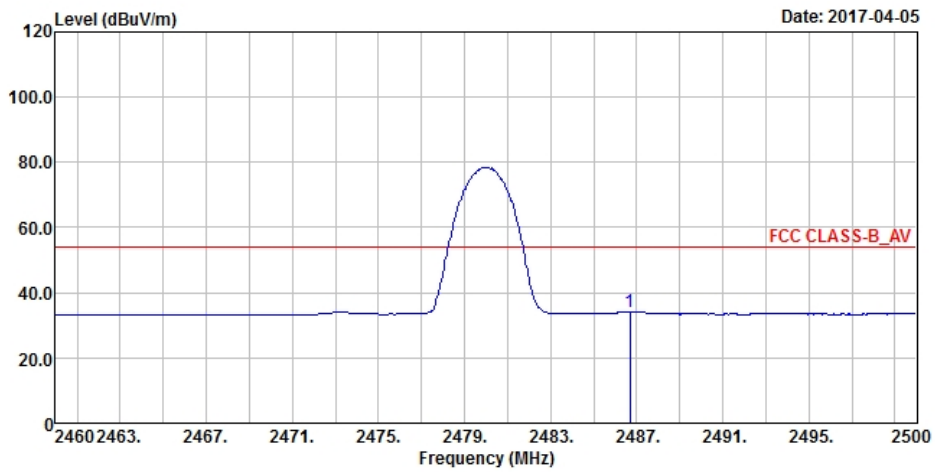

**Antenna Polarity & Test Distance: Horizontal at 3 m**

Frequency (MHz)	Emission Level (dBuV/m)	Read Level (dBuV)	Limit (dBuV/m)	Margin (dB)	Antenna Factor (dB/m)	Cable Loss (dB)	Preamp Factor (dB)	Antenna Height (cm)	Table Angle (Degree)	Remark
2480	82.86	88.88			27.15	4.15	37.32	208	195	Average
2480	96.57	102.59			27.15	4.15	37.32	208	195	Peak
2483.52	34.03	40.05	54	-19.97	27.15	4.15	37.32	208	195	Average
2499.44	47.29	53.18	74	-26.71	27.2	4.16	37.25	208	195	Peak
4960	32.97	47.94	54	-21.03	31.16	6.91	53.04	126	139	Average
4960	44.68	59.65	74	-29.32	31.16	6.91	53.04	126	139	Peak

**Antenna Polarity & Test Distance: Vertical at 3 m**

Frequency (MHz)	Emission Level (dBuV/m)	Read Level (dBuV)	Limit (dBuV/m)	Margin (dB)	Antenna Factor (dB/m)	Cable Loss (dB)	Preamp Factor (dB)	Antenna Height (cm)	Table Angle (Degree)	Remark
2480	78.81	84.83			27.15	4.15	37.32	198	354	Average
2480	91.34	97.36			27.15	4.15	37.32	198	354	Peak
2486.68	34.23	40.25	54	-19.77	27.15	4.15	37.32	198	354	Average
2491.72	47.14	53.1	74	-26.86	27.2	4.16	37.32	198	354	Peak
4960	32.66	47.63	54	-21.34	31.16	6.91	53.04	113	289	Average
4960	44.59	59.56	74	-29.41	31.16	6.91	53.04	113	289	Peak

Remarks:

- Emission Level = Read Level + Antenna Factor + Cable Loss - Preamp Factor  
Margin value = Emission level – Limit value
- 2480 MHz: Fundamental frequency.



### Mode B

EUT Test Condition		Measurement Detail	
Channel	Channel 78	Frequency Range	1 GHz ~ 25 GHz
Input Power	120 Vac, 60 Hz	Detector Function	Peak (PK) Average (AV)
Environmental Conditions	25 deg. C, 65 % RH	Tested By	Getaz Yang

### Horizontal

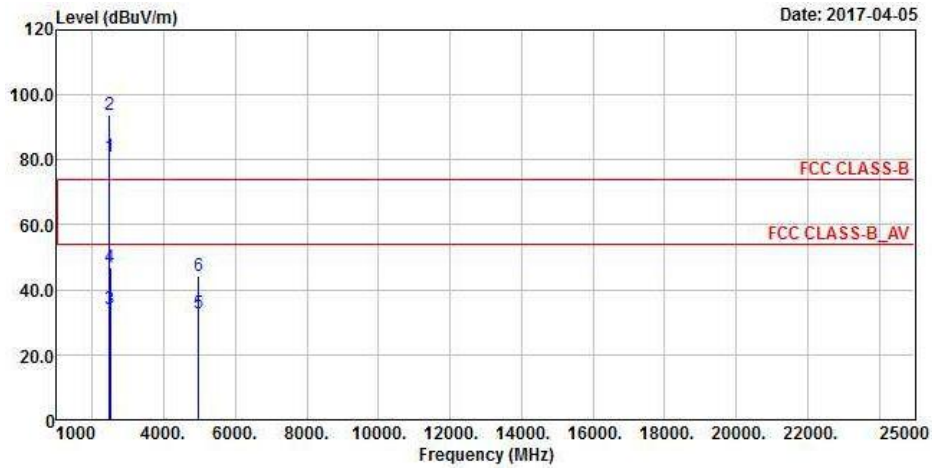

### Vertical

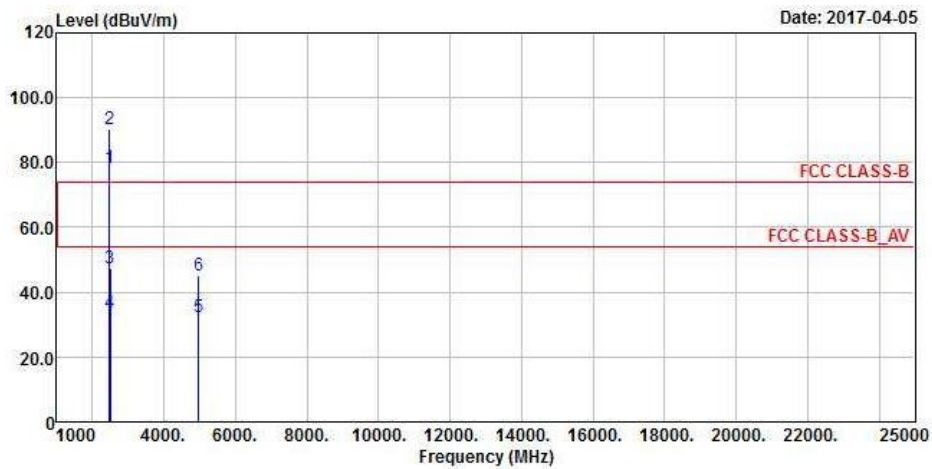

**Band Edge  
Peak  
Horizontal**

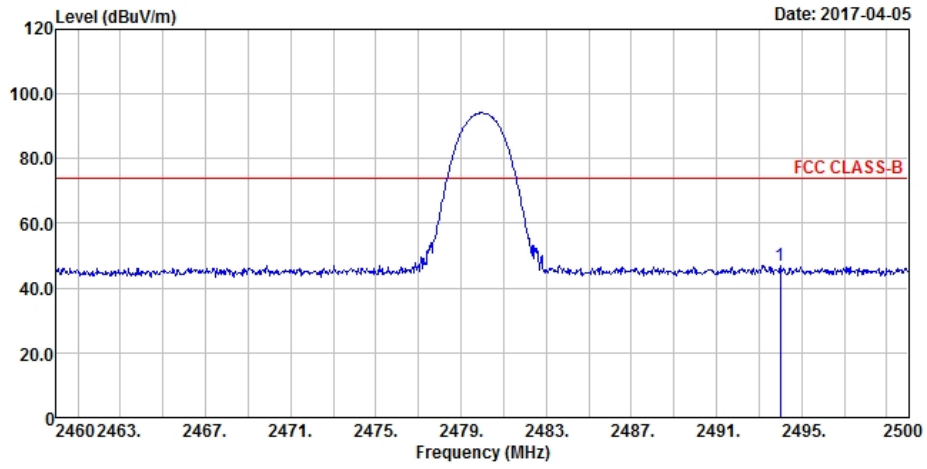

**Vertical**

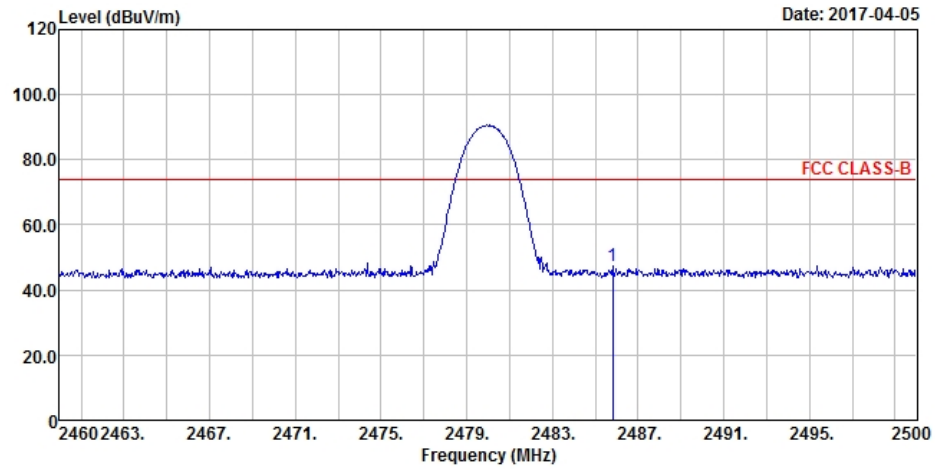

### Average Horizontal

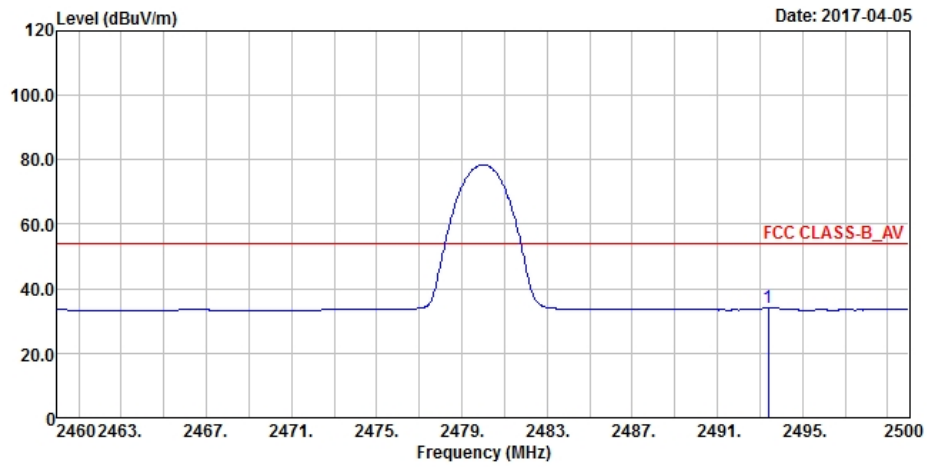

### Vertical

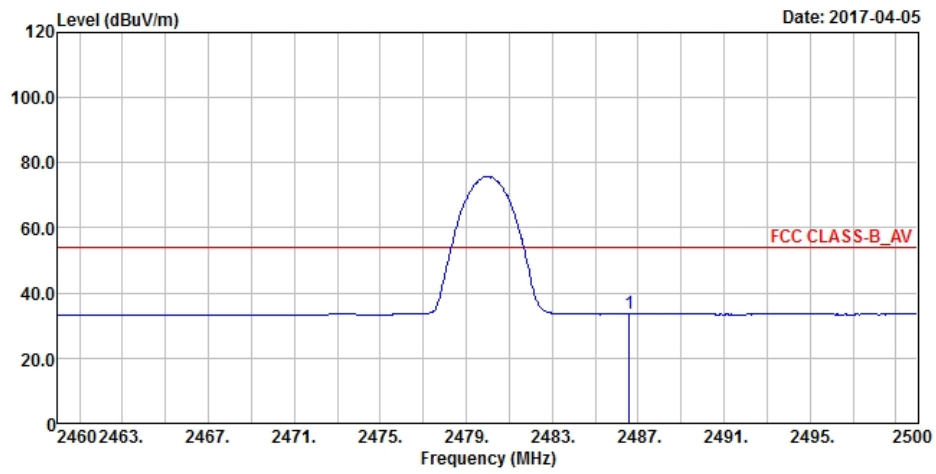

**Antenna Polarity & Test Distance: Horizontal at 3 m**

Frequency (MHz)	Emission Level (dBuV/m)	Read Level (dBuV)	Limit (dBuV/m)	Margin (dB)	Antenna Factor (dB/m)	Cable Loss (dB)	Preamp Factor (dB)	Antenna Height (cm)	Table Angle (Degree)	Remark
2480	80.86	86.88			27.15	4.15	37.32	149	188	Average
2480	93.82	99.84			27.15	4.15	37.32	149	188	Peak
2493.4	33.99	39.88	54	-20.01	27.2	4.16	37.25	149	188	Average
2494	46.94	52.83	74	-27.06	27.2	4.16	37.25	149	188	Peak
4960	32.74	47.71	54	-21.26	31.16	6.91	53.04	133	176	Average
4960	44.44	59.41	74	-29.56	31.16	6.91	53.04	133	176	Peak

**Antenna Polarity & Test Distance: Vertical at 3 m**

Frequency (MHz)	Emission Level (dBuV/m)	Read Level (dBuV)	Limit (dBuV/m)	Margin (dB)	Antenna Factor (dB/m)	Cable Loss (dB)	Preamp Factor (dB)	Antenna Height (cm)	Table Angle (Degree)	Remark
2480	78.36	84.38			27.15	4.15	37.32	143	87	Average
2480	90.42	96.44			27.15	4.15	37.32	143	87	Peak
2485.8	47.4	53.42	74	-26.6	27.15	4.15	37.32	143	87	Peak
2486.6	33.82	39.84	54	-20.18	27.15	4.15	37.32	143	87	Average
4960	32.31	47.28	54	-21.69	31.16	6.91	53.04	125	243	Average
4960	45.17	60.14	74	-28.83	31.16	6.91	53.04	125	243	Peak

Remarks:

- Emission Level = Read Level + Antenna Factor + Cable Loss - Preamp Factor  
Margin value = Emission level – Limit value
- 2480 MHz: Fundamental frequency.

### Mode C

EUT Test Condition		Measurement Detail	
Channel	Channel 78	Frequency Range	1 GHz ~ 25 GHz
Input Power	120 Vac, 60 Hz	Detector Function	Peak (PK) Average (AV)
Environmental Conditions	25 deg. C, 65 % RH	Tested By	Getaz Yang

### Horizontal

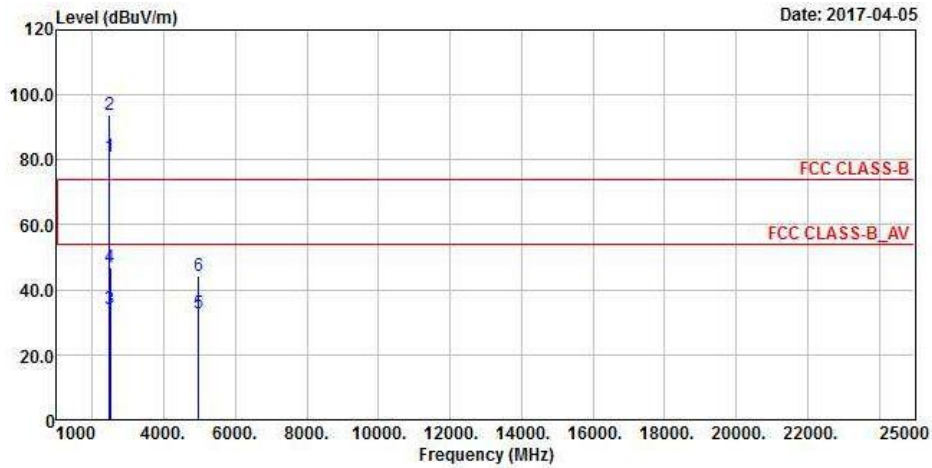

### Vertical

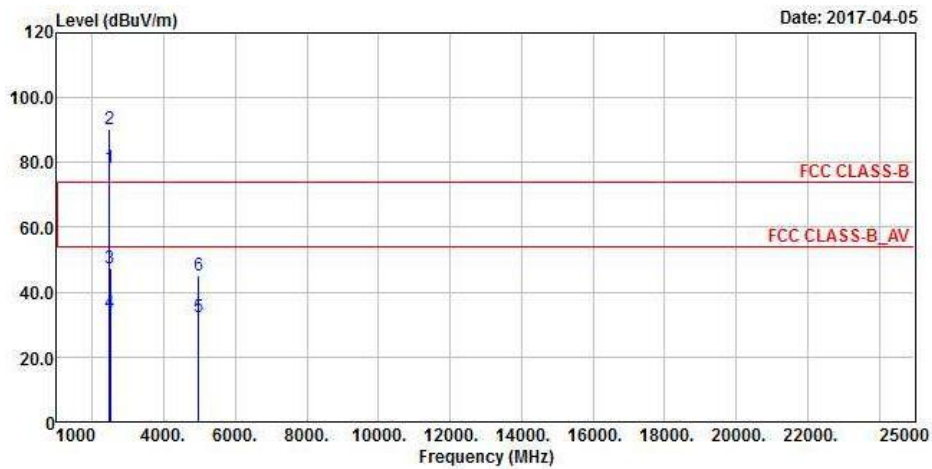

**Band Edge  
Peak  
Horizontal**

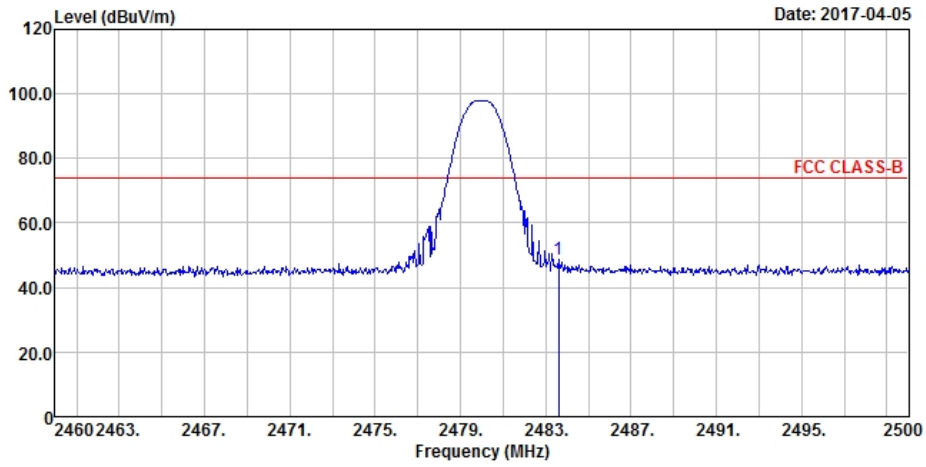

**Vertical**

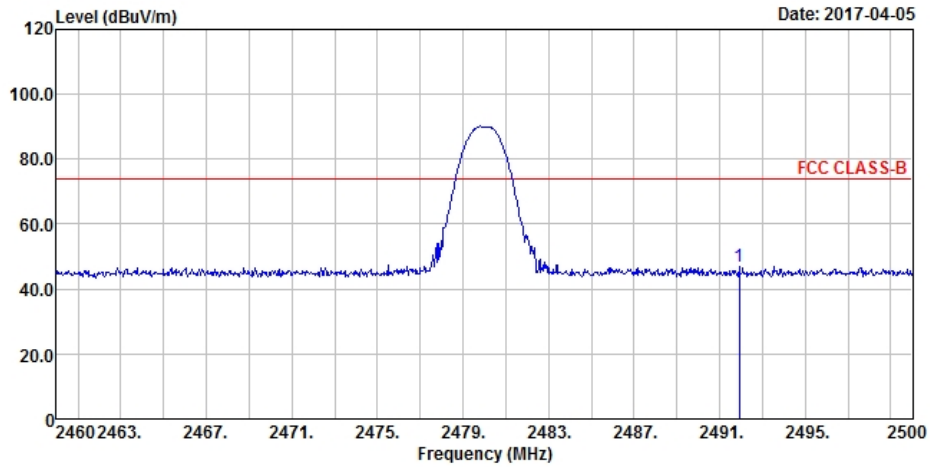

### Average Horizontal

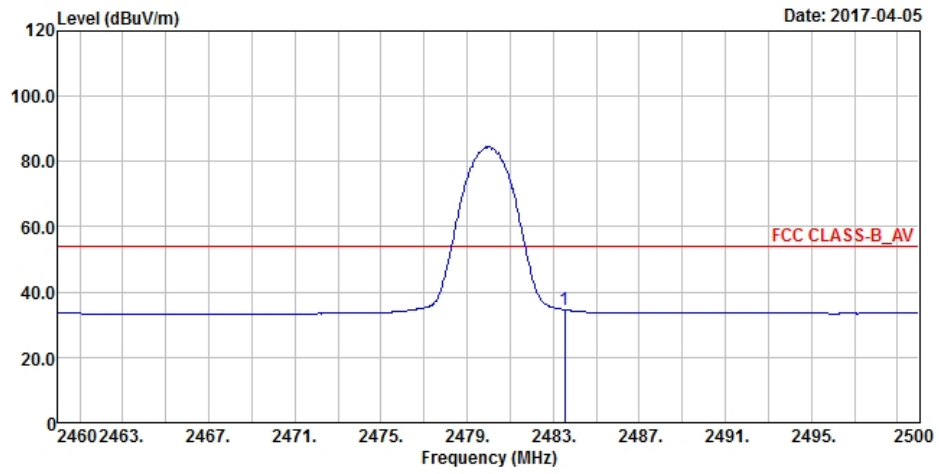

### Vertical

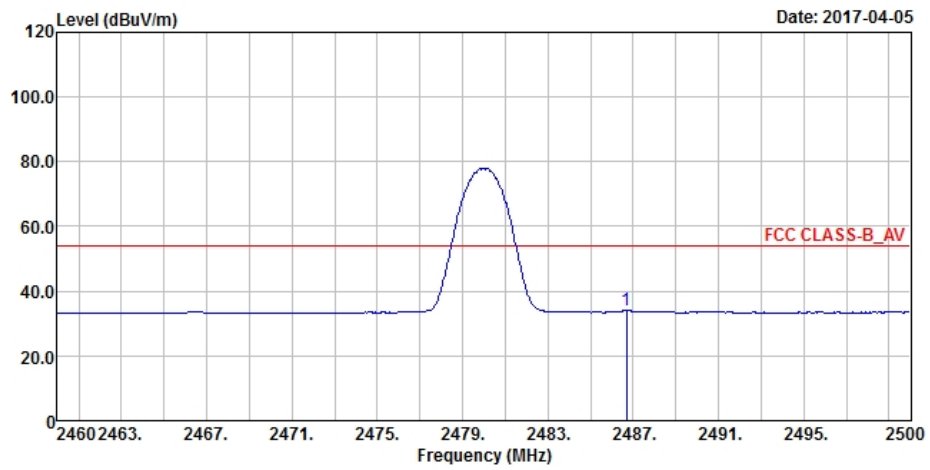

**Antenna Polarity & Test Distance: Horizontal at 3 m**

Frequency (MHz)	Emission Level (dBuV/m)	Read Level (dBuV)	Limit (dBuV/m)	Margin (dB)	Antenna Factor (dB/m)	Cable Loss (dB)	Preamp Factor (dB)	Antenna Height (cm)	Table Angle (Degree)	Remark
2480	86.77	92.79			27.15	4.15	37.32	164	29	Average
2480	98.13	104.15			27.15	4.15	37.32	164	29	Peak
2483.52	34.63	40.65	54	-19.37	27.15	4.15	37.32	164	29	Average
2483.6	48.57	54.59	74	-25.43	27.15	4.15	37.32	164	29	Peak
4960	32.65	47.62	54	-21.35	31.16	6.91	53.04	167	153	Average
4960	44.69	59.66	74	-29.31	31.16	6.91	53.04	167	153	Peak

**Antenna Polarity & Test Distance: Vertical at 3 m**

Frequency (MHz)	Emission Level (dBuV/m)	Read Level (dBuV)	Limit (dBuV/m)	Margin (dB)	Antenna Factor (dB/m)	Cable Loss (dB)	Preamp Factor (dB)	Antenna Height (cm)	Table Angle (Degree)	Remark
2480	80.93	86.95			27.15	4.15	37.32	180	352	Average
2480	90.55	96.57			27.15	4.15	37.32	180	352	Peak
2486.68	33.94	39.96	54	-20.06	27.15	4.15	37.32	180	352	Average
2491.92	46.8	52.69	74	-27.2	27.2	4.16	37.25	180	352	Peak
4960	32.24	47.21	54	-21.76	31.16	6.91	53.04	105	229	Average
4960	45.02	59.99	74	-28.98	31.16	6.91	53.04	105	229	Peak

Remarks:

- Emission Level = Read Level + Antenna Factor + Cable Loss - Preamp Factor  
Margin value = Emission level – Limit value
- 2480 MHz: Fundamental frequency.



**9 kHz ~ 30 MHz DATA:**

The amplitude of spurious emissions attenuated more than 20 dB below the permissible value is not required to be report.

**30 MHz ~ 1 GHz WORST-CASE DATA:**

**Mode A**

EUT Test Condition		Measurement Detail	
Channel	Channel 78	Frequency Range	30 MHz ~ 1 GHz
Input Power	120 Vac, 60 Hz	Detector Function	Peak (PK) Quasi-peak (QP)
Environmental Conditions	25 deg. C, 65 % RH	Tested By	Getaz Yang

**Horizontal**

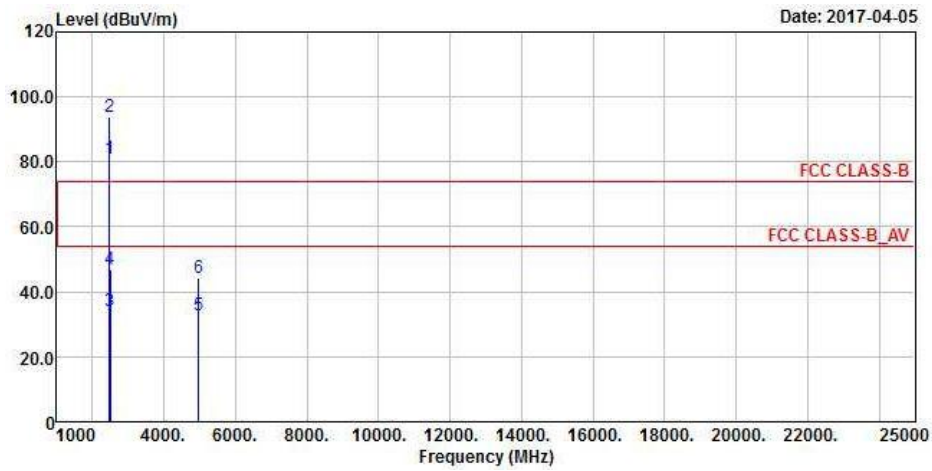

**Vertical**

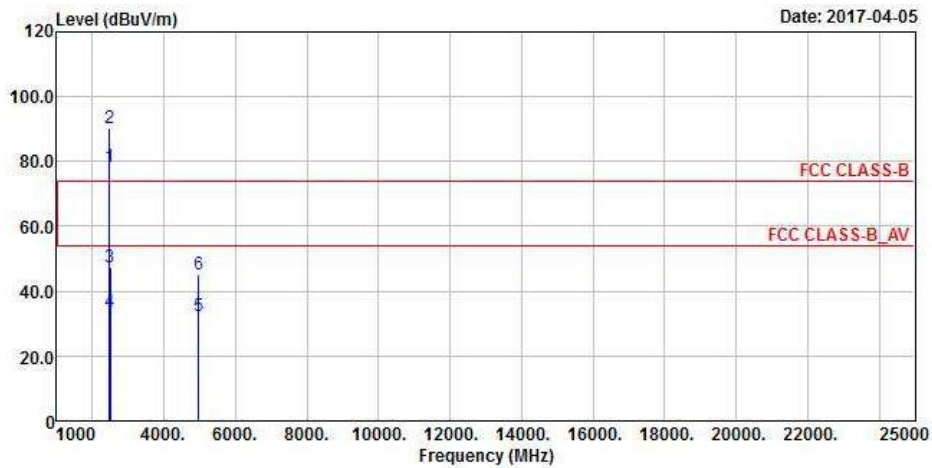

**Antenna Polarity & Test Distance: Horizontal at 3 m**

Frequency (MHz)	Emission Level (dBuV/m)	Read Level (dBuV)	Limit (dBuV/m)	Margin (dB)	Antenna Factor (dB/m)	Cable Loss (dB)	Preamp Factor (dB)	Antenna Height (cm)	Table Angle (Degree)	Remark
32.91	24.26	42.28	40	-15.74	12.47	0.6	31.09	109	13	Peak
91.11	24.52	47.13	43.5	-18.98	8.38	0.97	31.96	103	336	Peak
108.57	27.05	47.9	43.5	-16.45	9.9	1.1	31.85	129	257	Peak
159.01	22.17	40.15	43.5	-21.33	12.73	1.14	31.85	126	69	Peak
180.35	20.98	40.86	43.5	-22.52	10.74	1.22	31.84	105	70	Peak
287.05	19.09	36.64	46	-26.91	12.57	1.6	31.72	129	337	Peak

**Antenna Polarity & Test Distance: Vertical at 3 m**

Frequency (MHz)	Emission Level (dBuV/m)	Read Level (dBuV)	Limit (dBuV/m)	Margin (dB)	Antenna Factor (dB/m)	Cable Loss (dB)	Preamp Factor (dB)	Antenna Height (cm)	Table Angle (Degree)	Remark
31.94	37.38	55.6	40	-2.62	12.3	0.59	31.11	111	252	Peak
41.64	30.19	47.02	40	-9.81	13.56	0.66	31.05	115	107	Peak
66.86	30.09	49.8	40	-9.91	11.12	0.85	31.68	117	101	Peak
89.17	26.35	49.02	43.5	-17.15	8.28	0.96	31.91	133	217	Peak
159.98	20.8	38.8	43.5	-22.7	12.73	1.15	31.88	118	262	Peak
280.26	20.77	38.64	46	-25.23	12.37	1.58	31.82	134	77	Peak

Remarks:

- Emission Level = Read Level + Antenna Factor + Cable Loss - Preamp Factor  
Margin value = Emission level – Limit value

**Mode B**

EUT Test Condition		Measurement Detail	
Channel	Channel 78	Frequency Range	30 MHz ~ 1 GHz
Input Power	120 Vac, 60 Hz	Detector Function	Peak (PK) Quasi-peak (QP)
Environmental Conditions	25 deg. C, 65 % RH	Tested By	Getaz Yang

**Horizontal**

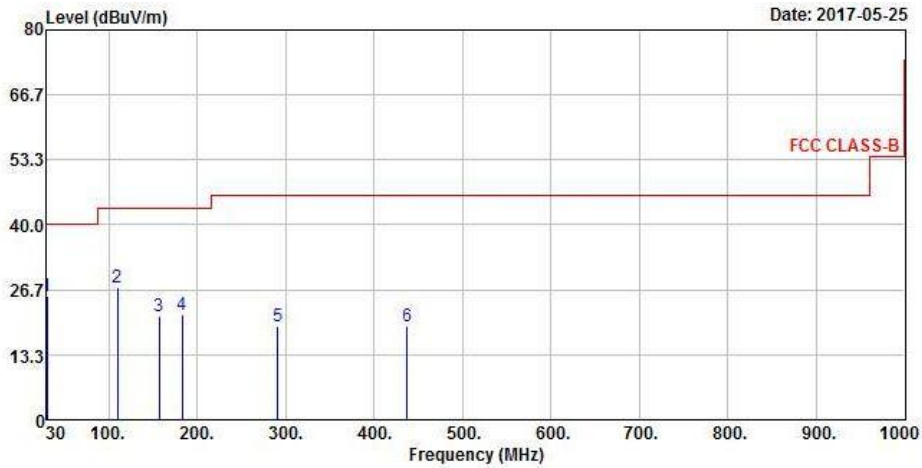

**Vertical**

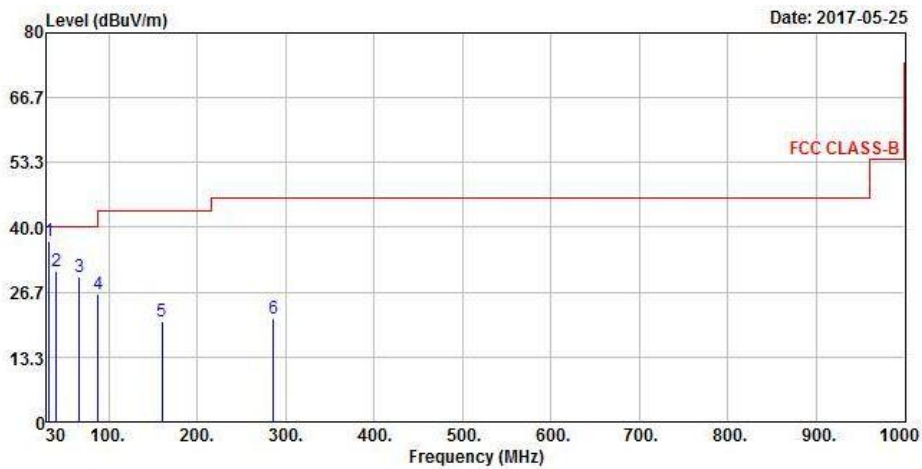

**Antenna Polarity & Test Distance: Horizontal at 3 m**

Frequency (MHz)	Emission Level (dBuV/m)	Read Level (dBuV)	Limit (dBuV/m)	Margin (dB)	Antenna Factor (dB/m)	Cable Loss (dB)	Preamp Factor (dB)	Antenna Height (cm)	Table Angle (Degree)	Remark
30	25.43	44.01	40	-14.57	11.98	0.58	31.14	114	238	Peak
109.54	27.06	47.81	43.5	-16.44	9.99	1.1	31.84	139	44	Peak
157.07	21.13	39.08	43.5	-22.37	12.72	1.13	31.8	138	261	Peak
183.26	21.62	41.65	43.5	-21.88	10.53	1.23	31.79	119	13	Peak
290.93	19.23	36.63	46	-26.77	12.68	1.61	31.69	114	10	Peak
437.4	19.33	33.28	46	-26.67	16.08	1.97	32	108	113	Peak

**Antenna Polarity & Test Distance: Vertical at 3 m**

Frequency (MHz)	Emission Level (dBuV/m)	Read Level (dBuV)	Limit (dBuV/m)	Margin (dB)	Antenna Factor (dB/m)	Cable Loss (dB)	Preamp Factor (dB)	Antenna Height (cm)	Table Angle (Degree)	Remark
32.91	37.1	55.12	40	-2.9	12.47	0.6	31.09	122	307	Peak
40.67	31.02	47.84	40	-8.98	13.55	0.65	31.02	121	119	Peak
66.86	29.73	49.44	40	-10.27	11.12	0.85	31.68	120	96	Peak
88.2	26.37	49.02	43.5	-17.13	8.27	0.95	31.87	124	62	Peak
159.98	20.75	38.75	43.5	-22.75	12.73	1.15	31.88	126	139	Peak
286.08	21.11	38.71	46	-24.89	12.54	1.59	31.73	118	66	Peak

Remarks:

- Emission Level = Read Level + Antenna Factor + Cable Loss - Preamp Factor  
Margin value = Emission level – Limit value

**Mode C**

EUT Test Condition		Measurement Detail	
Channel	Channel 78	Frequency Range	30 MHz ~ 1 GHz
Input Power	120 Vac, 60 Hz	Detector Function	Peak (PK) Quasi-peak (QP)
Environmental Conditions	25 deg. C, 65 % RH	Tested By	Getaz Yang

**Horizontal**

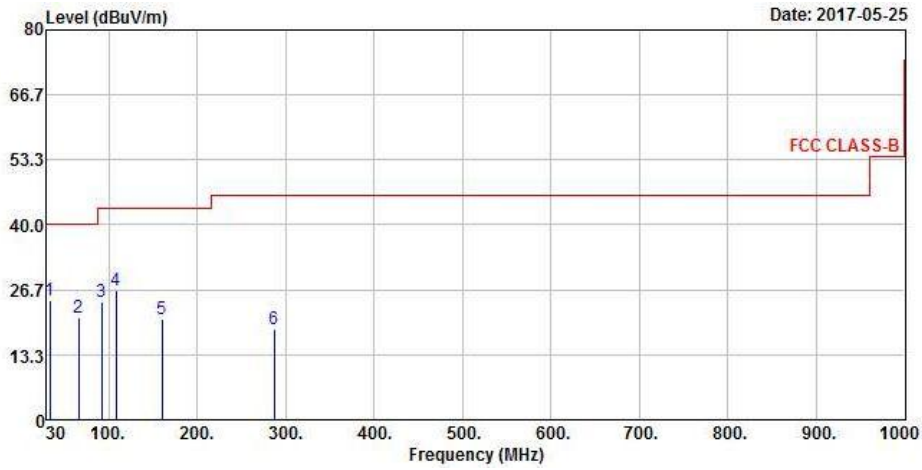

**Vertical**

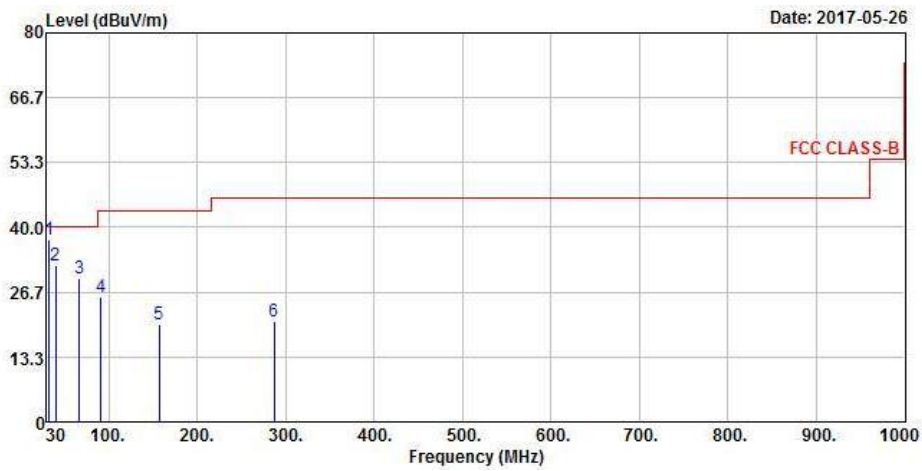

**Antenna Polarity & Test Distance: Horizontal at 3 m**

Frequency (MHz)	Emission Level (dBuV/m)	Read Level (dBuV)	Limit (dBuV/m)	Margin (dB)	Antenna Factor (dB/m)	Cable Loss (dB)	Preamp Factor (dB)	Antenna Height (cm)	Table Angle (Degree)	Remark
33.88	24.63	42.48	40	-15.37	12.63	0.6	31.08	111	126	Peak
65.89	20.91	40.46	40	-19.09	11.24	0.85	31.64	137	150	Peak
92.08	24.16	46.68	43.5	-19.34	8.45	0.99	31.96	102	259	Peak
108.57	26.69	47.54	43.5	-16.81	9.9	1.1	31.85	106	187	Peak
159.98	20.63	38.63	43.5	-22.87	12.73	1.15	31.88	132	256	Peak
287.05	18.61	36.16	46	-27.39	12.57	1.6	31.72	134	347	Peak

**Antenna Polarity & Test Distance: Vertical at 3 m**

Frequency (MHz)	Emission Level (dBuV/m)	Read Level (dBuV)	Limit (dBuV/m)	Margin (dB)	Antenna Factor (dB/m)	Cable Loss (dB)	Preamp Factor (dB)	Antenna Height (cm)	Table Angle (Degree)	Remark
32.91	37.59	55.61	40	-2.41	12.47	0.6	31.09	123	227	Peak
39.7	32.12	48.93	40	-7.88	13.54	0.64	30.99	105	137	Peak
66.86	29.58	49.29	40	-10.42	11.12	0.85	31.68	134	186	Peak
91.11	25.6	48.21	43.5	-17.9	8.38	0.97	31.96	126	105	Peak
157.07	20.09	38.04	43.5	-23.41	12.72	1.13	31.8	139	113	Peak
287.05	20.65	38.2	46	-25.35	12.57	1.6	31.72	121	92	Peak

Remarks:

- Emission Level = Read Level + Antenna Factor + Cable Loss - Preamp Factor  
Margin value = Emission level – Limit value

## 4.2 Conducted Emission Measurement

### 4.2.1 Limits of Conducted Emission Measurement

Frequency (MHz)	Conducted Limit (dBuV)	
	Quasi-peak	Average
0.15 - 0.5	66 - 56	56 - 46
0.50 - 5.0	56	46
5.0 - 30.0	60	50

- Note: 1. The lower limit shall apply at the transition frequencies.  
 2. The limit decreases in line with the logarithm of the frequency in the range of 0.15 to 0.50 MHz.  
 3. All emanations from a class A/B digital device or system, including any network of conductors and apparatus connected thereto, shall not exceed the level of field strengths specified above.

### 4.2.2 Test Instruments

Description & Manufacturer	Model No.	Serial No.	Date Of Calibration	Due Date Of Calibration
Test Receiver ROHDE & SCHWARZ	ESCI	100613	Nov. 21, 2016	Nov. 20, 2017
RF signal cable (with 10dB PAD) Woken	5D-FB	Cable-cond1-01	Dec. 22, 2016	Dec. 21, 2017
LISN ROHDE & SCHWARZ (EUT)	ESH3-Z5	835239/001	Mar. 10, 2017	Mar. 09, 2018
LISN ROHDE & SCHWARZ (Peripheral)	ESH3-Z5	100311	Jul. 28, 2016	Jul. 27, 2017
Software ADT	BV ADT_Cond_ V7.3.7.3	NA	NA	NA

- Note: 1. The calibration interval of the above test instruments is 12 months and the calibrations are traceable to NML/ROC and NIST/USA.  
 2. The test was performed in HwaYa Shielded Room 1.  
 3. The VCCI Site Registration No. is C-2040.

#### 4.2.3 Test Procedures

- a. The EUT was placed 0.4 meters from the conducting wall of the shielded room with EUT being connected to the power mains through a line impedance stabilization network (LISN). Other support units were connected to the power mains through another LISN. The two LISNs provide 50 ohm/ 50 uH of coupling impedance for the measuring instrument.
- b. Both lines of the power mains connected to the EUT were checked for maximum conducted interference.
- c. The frequency range from 150 kHz to 30 MHz was searched. Emission levels under (Limit – 20 dB) was not recorded.

**Note:** All modes of operation were investigated and the worst-case emissions are reported.

#### 4.2.4 Deviation from Test Standard

No deviation.

#### 4.2.5 Test Setup

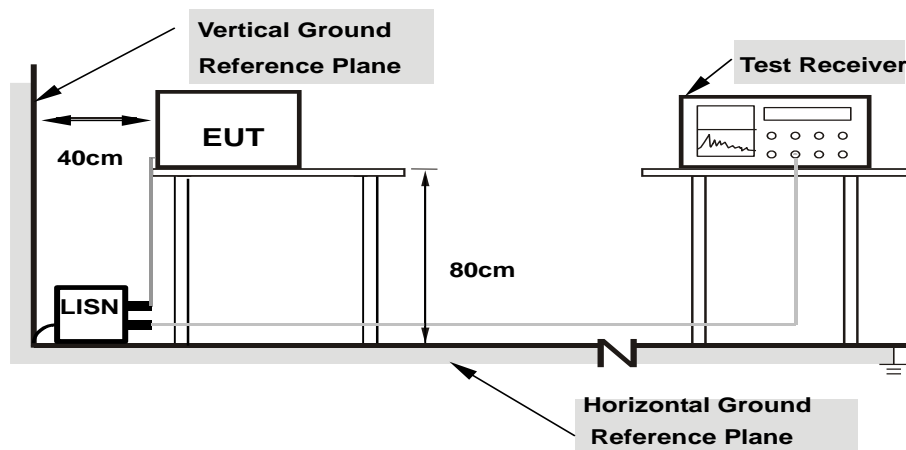

- Note:**
- 1.Support units were connected to second LISN.
  - 2.Both of LISNs (AMN) are 80 cm from EUT and at least 80 from other units and other metal planes

For the actual test configuration, please refer to the attached file (Test Setup Photo).

#### 4.2.6 EUT Operating Condition

Set the EUT under transmission condition continuously at specific channel frequency.



4.2.7 Test Results

**CONDUCTED WORST-CASE DATA : 8DPSK**

**Mode A**

Frequency Range	150kHz ~ 30MHz	Detector Function & Resolution Bandwidth	Quasi-Peak (QP) / Average (AV), 9kHz
Input Power	120Vac, 60Hz	Environmental Conditions	25°C, 65%RH
Tested by	Getaz Yang	Test Date	2017/5/27

Phase Of Power : Line (L)										
No	Frequency (MHz)	Correction Factor (dB)	Reading Value (dBuV)		Emission Level (dBuV)		Limit (dBuV)		Margin (dB)	
			Q.P.	AV.	Q.P.	AV.	Q.P.	AV.	Q.P.	AV.
1	0.15400	10.35	38.08	21.79	48.43	32.14	65.78	55.78	-17.35	-23.64
2	0.81800	10.40	19.05	12.85	29.45	23.25	56.00	46.00	-26.55	-22.75
3	1.50200	10.43	34.64	30.07	45.07	40.50	56.00	46.00	-10.93	-5.50
4	2.13800	10.47	11.51	4.47	21.98	14.94	56.00	46.00	-34.02	-31.06
5	2.46600	10.49	17.25	9.91	27.74	20.40	56.00	46.00	-28.26	-25.60
6	4.21400	10.58	29.47	20.76	40.05	31.34	56.00	46.00	-15.95	-14.66

Remarks:

1. Q.P. and AV. are abbreviations of quasi-peak and average individually.
2. The emission levels of other frequencies were very low against the limit.
3. Margin value = Emission level – Limit value
4. Correction factor = Insertion loss + Cable loss
5. Emission Level = Correction Factor + Reading Value

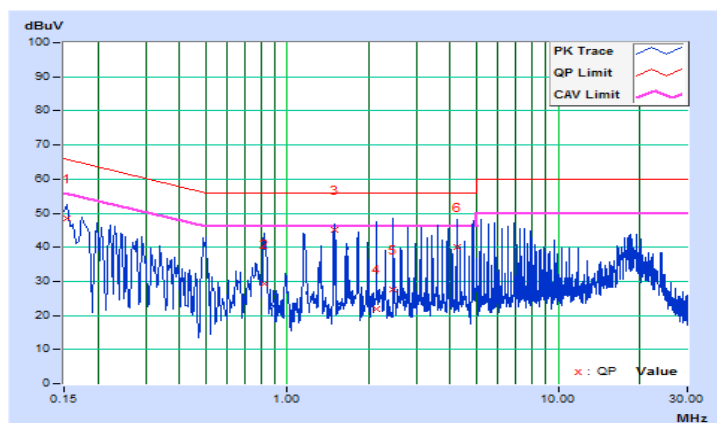

Frequency Range	150kHz ~ 30MHz	Detector Function & Resolution Bandwidth	Quasi-Peak (QP) / Average (AV), 9kHz
Input Power	120Vac, 60Hz	Environmental Conditions	25°C, 65%RH
Tested by	Getaz Yang	Test Date	2017/5/27

Phase Of Power : Neutral (N)										
No	Frequency (MHz)	Correction Factor (dB)	Reading Value (dBuV)		Emission Level (dBuV)		Limit (dBuV)		Margin (dB)	
			Q.P.	AV.	Q.P.	AV.	Q.P.	AV.	Q.P.	AV.
1	0.49346	10.16	33.32	27.60	43.48	37.76	56.11	46.11	-12.63	-8.35
2	0.83000	10.17	41.07	34.00	51.24	44.17	56.00	46.00	-4.76	-1.83
3	1.15000	10.18	14.57	6.90	24.75	17.08	56.00	46.00	-31.25	-28.92
4	1.80600	10.22	33.09	28.59	43.31	38.81	56.00	46.00	-12.69	-7.19
5	3.12200	10.29	26.12	21.70	36.41	31.99	56.00	46.00	-19.59	-14.01
6	5.29400	10.39	28.89	15.06	39.28	25.45	60.00	50.00	-20.72	-24.55

Remarks:

1. Q.P. and AV. are abbreviations of quasi-peak and average individually.
2. The emission levels of other frequencies were very low against the limit.
3. Margin value = Emission level – Limit value
4. Correction factor = Insertion loss + Cable loss
5. Emission Level = Correction Factor + Reading Value

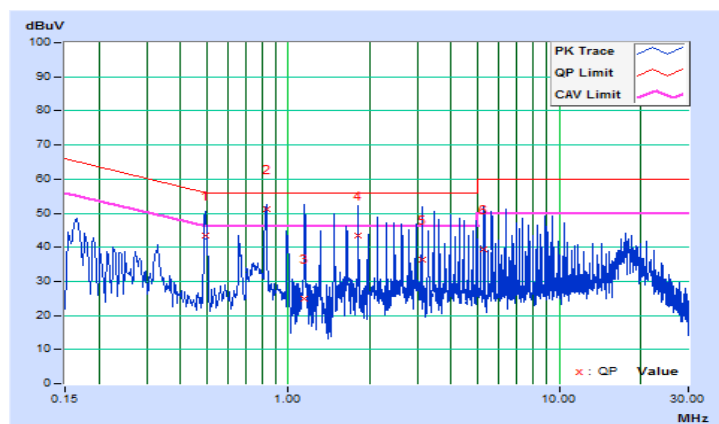

**Mode B**

Frequency Range	150kHz ~ 30MHz	Detector Function & Resolution Bandwidth	Quasi-Peak (QP) / Average (AV), 9kHz
Input Power	120Vac, 60Hz	Environmental Conditions	25°C, 65%RH
Tested by	Getaz Yang	Test Date	2017/5/27

Phase Of Power : Line (L)										
No	Frequency (MHz)	Correction Factor (dB)	Reading Value (dBuV)		Emission Level (dBuV)		Limit (dBuV)		Margin (dB)	
			Q.P.	AV.	Q.P.	AV.	Q.P.	AV.	Q.P.	AV.
1	0.51335	10.40	36.44	32.07	46.84	42.47	56.00	46.00	-9.16	-3.53
2	0.85808	10.40	31.18	26.71	41.58	37.11	56.00	46.00	-14.42	-8.89
3	1.54200	10.43	13.76	2.68	24.19	13.11	56.00	46.00	-31.81	-32.89
4	1.88600	10.45	15.16	9.63	25.61	20.08	56.00	46.00	-30.39	-25.92
5	2.56200	10.49	30.21	25.93	40.70	36.42	56.00	46.00	-15.30	-9.58
6	4.08200	10.57	10.71	4.12	21.28	14.69	56.00	46.00	-34.72	-31.31

Remarks:

1. Q.P. and AV. are abbreviations of quasi-peak and average individually.
2. The emission levels of other frequencies were very low against the limit.
3. Margin value = Emission level – Limit value
4. Correction factor = Insertion loss + Cable loss
5. Emission Level = Correction Factor + Reading Value

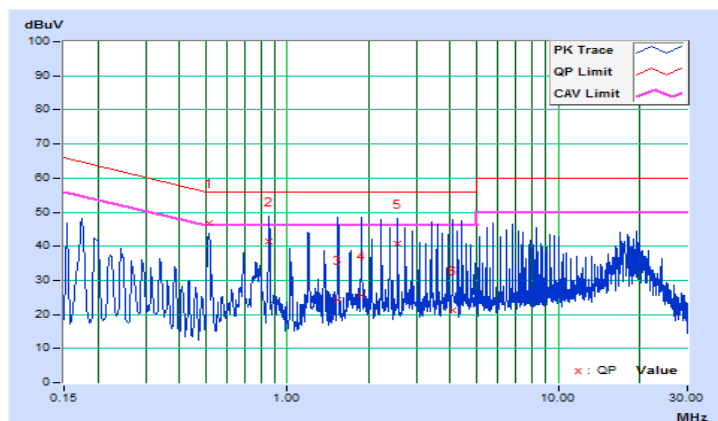

Frequency Range	150kHz ~ 30MHz	Detector Function & Resolution Bandwidth	Quasi-Peak (QP) / Average (AV), 9kHz
Input Power	120Vac, 60Hz	Environmental Conditions	25°C, 65%RH
Tested by	Getaz Yang	Test Date	2017/5/27

Phase Of Power : Neutral (N)										
No	Frequency (MHz)	Correction Factor (dB)	Reading Value (dBuV)		Emission Level (dBuV)		Limit (dBuV)		Margin (dB)	
			Q.P.	AV.	Q.P.	AV.	Q.P.	AV.	Q.P.	AV.
1	0.51400	10.16	40.45	34.37	50.61	44.53	56.00	46.00	-5.39	-1.47
2	0.85400	10.17	38.01	33.67	48.18	43.84	56.00	46.00	-7.82	-2.16
3	1.18649	10.18	35.42	27.27	45.60	37.45	56.00	46.00	-10.40	-8.55
4	1.86200	10.22	19.79	14.68	30.01	24.90	56.00	46.00	-25.99	-21.10
5	2.21000	10.24	17.15	8.07	27.39	18.31	56.00	46.00	-28.61	-27.69
6	4.76200	10.37	39.94	33.81	50.31	44.18	56.00	46.00	-5.69	-1.82

Remarks:

1. Q.P. and AV. are abbreviations of quasi-peak and average individually.
2. The emission levels of other frequencies were very low against the limit.
3. Margin value = Emission level – Limit value
4. Correction factor = Insertion loss + Cable loss
5. Emission Level = Correction Factor + Reading Value

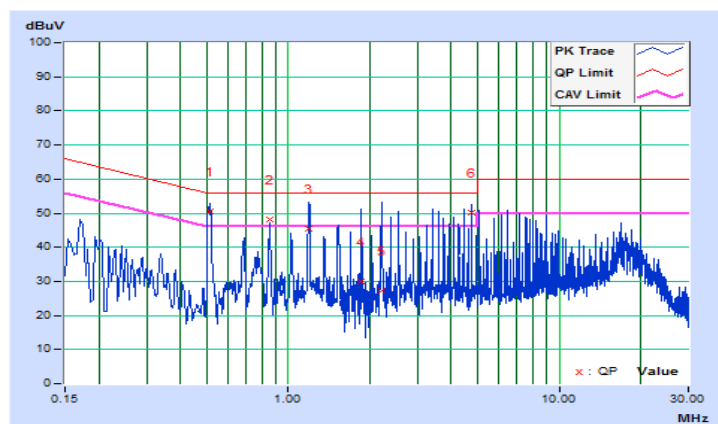

### Mode C

Frequency Range	150kHz ~ 30MHz	Detector Function & Resolution Bandwidth	Quasi-Peak (QP) / Average (AV), 9kHz
Input Power	120Vac, 60Hz	Environmental Conditions	25°C, 65%RH
Tested by	Getaz Yang	Test Date	2017/5/27

Phase Of Power : Line (L)										
No	Frequency (MHz)	Correction Factor (dB)	Reading Value (dBuV)		Emission Level (dBuV)		Limit (dBuV)		Margin (dB)	
			Q.P.	AV.	Q.P.	AV.	Q.P.	AV.	Q.P.	AV.
1	0.49737	10.40	20.68	15.96	31.08	26.36	56.04	46.04	-24.96	-19.68
2	0.83000	10.40	33.40	29.77	43.80	40.17	56.00	46.00	-12.20	-5.83
3	1.16200	10.41	9.84	5.28	20.25	15.69	56.00	46.00	-35.75	-30.31
4	1.83400	10.45	14.24	10.30	24.69	20.75	56.00	46.00	-31.31	-25.25
5	2.49800	10.49	12.17	2.33	22.66	12.82	56.00	46.00	-33.34	-33.18
6	4.96200	10.61	10.07	3.84	20.68	14.45	56.00	46.00	-35.32	-31.55

Remarks:

1. Q.P. and AV. are abbreviations of quasi-peak and average individually.
2. The emission levels of other frequencies were very low against the limit.
3. Margin value = Emission level – Limit value
4. Correction factor = Insertion loss + Cable loss
5. Emission Level = Correction Factor + Reading Value

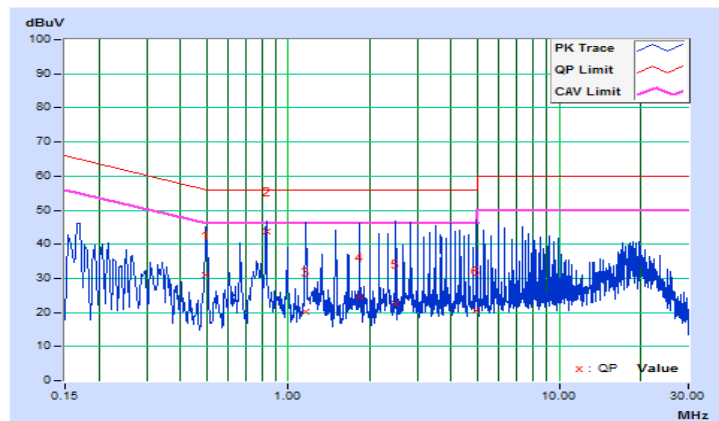

Frequency Range	150kHz ~ 30MHz	Detector Function & Resolution Bandwidth	Quasi-Peak (QP) / Average (AV), 9kHz
Input Power	120Vac, 60Hz	Environmental Conditions	25°C, 65%RH
Tested by	Getaz Yang	Test Date	2017/5/27

Phase Of Power : Neutral (N)										
No	Frequency (MHz)	Correction Factor (dB)	Reading Value (dBuV)		Emission Level (dBuV)		Limit (dBuV)		Margin (dB)	
			Q.P.	AV.	Q.P.	AV.	Q.P.	AV.	Q.P.	AV.
1	0.50200	10.16	34.64	30.60	44.80	40.76	56.00	46.00	-11.20	-5.24
2	0.83400	10.17	40.32	34.45	50.49	44.62	56.00	46.00	-5.51	-1.38
3	1.18200	10.18	38.98	33.07	49.16	43.25	56.00	46.00	-6.84	-2.75
4	1.51800	10.20	39.38	33.27	49.58	43.47	56.00	46.00	-6.42	-2.53
5	1.85800	10.22	41.74	34.98	51.96	45.20	56.00	46.00	-4.04	-0.80
6	2.50600	10.26	14.02	4.69	24.28	14.95	56.00	46.00	-31.72	-31.05

Remarks:

1. Q.P. and AV. are abbreviations of quasi-peak and average individually.
2. The emission levels of other frequencies were very low against the limit.
3. Margin value = Emission level – Limit value
4. Correction factor = Insertion loss + Cable loss
5. Emission Level = Correction Factor + Reading Value

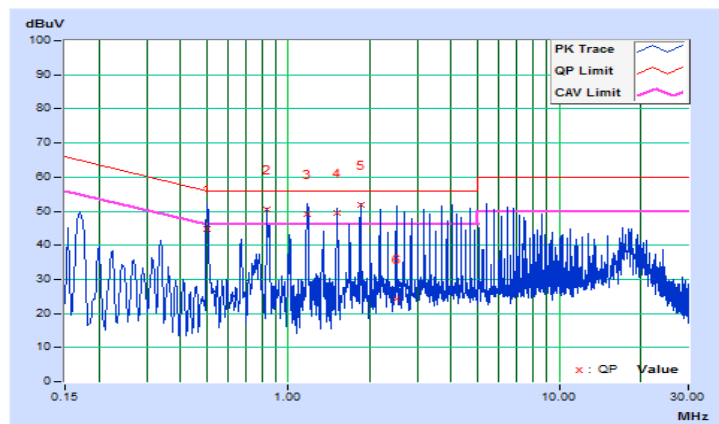

### 4.3 Number of Hopping Frequency Used

#### 4.3.1 Limits of Hopping Frequency Used Measurement

At least 15 channels frequencies, and should be equally spaced.

#### 4.3.2 Test Setup

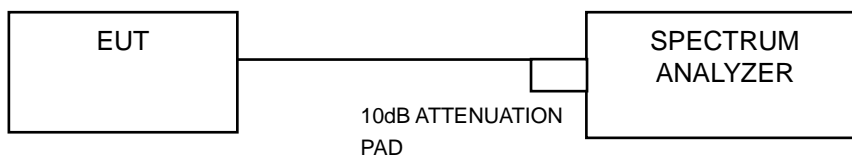

#### 4.3.3 Test Instruments

Refer to section 4.1.2 to get information of above instrument.

#### 4.3.4 Test Procedure

- Check the calibration of the measuring instrument (SA) using either an internal calibrator or a known signal from an external generator.
- Turn on the EUT and connect its antenna terminal to measurement via a low loss cable. Then set it to any one measured frequency within its operating range and make sure the instrument is operated in its linear range.
- Set the SA on MaxHold Mode, and then keep the EUT in hopping mode. Record all the signals from each channel until each one has been recorded.
- Set the SA on View mode and then plot the result on SA screen.
- Repeat above procedures until all frequencies measured were complete.

#### 4.3.5 Deviation from Test Standard

No deviation.

#### 4.3.6 Test Results

There are 79 hopping frequencies in the hopping mode. Please refer to next page for the test result. On the plots, it shows that the hopping frequencies are equally spaced.

# 8DPSK

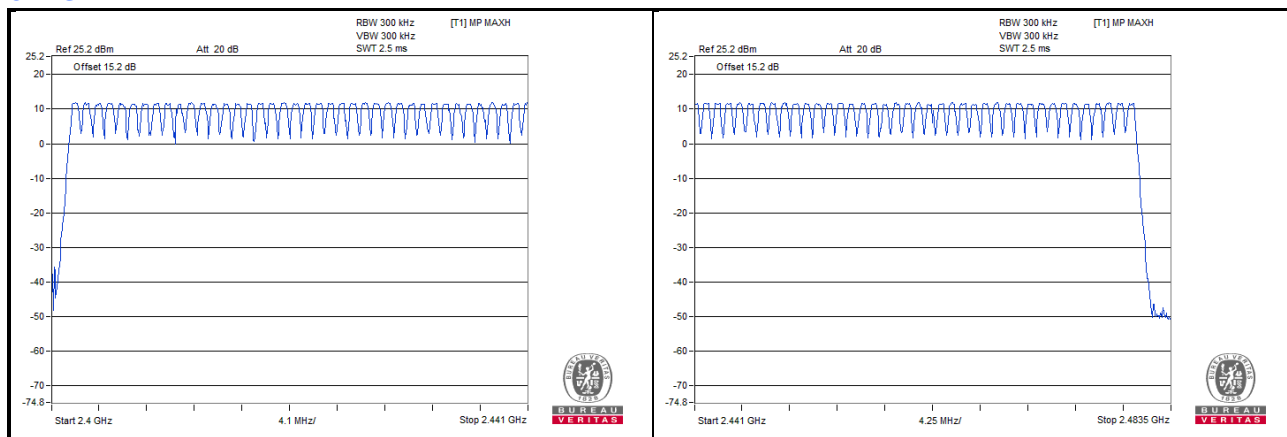



#### 4.4 Dwell Time on Each Channel

##### 4.4.1 Limits of Dwell Time on Each Channel Measurement

The average time of occupancy on any channel shall not be greater than 0.4 seconds within a period of 0.4 seconds multiplied by the number of hopping channels employed.

##### 4.4.2 Test Setup

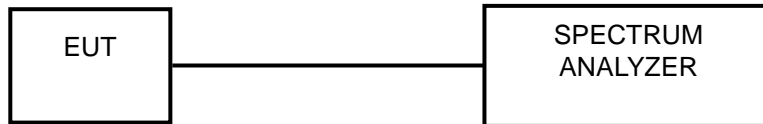

##### 4.4.3 Test Instruments

Refer to section 4.1.2 to get information of above instrument.

##### 4.4.4 Test Procedures

- a. Check the calibration of the measuring instrument (SA) using either an internal calibrator or a known signal from an external generator.
- b. Turn on the EUT and connect its antenna terminal to measurement via a low loss cable. Then set it to any one measured frequency within its operating range and make sure the instrument is operated in its linear range.
- c. Adjust the center frequency of SA on any frequency be measured and set SA to zero span mode. And then, set RBW and VBW of spectrum analyzer to proper value.
- d. Measure the time duration of one transmission on the measured frequency. And then plot the result with time difference of this time duration.
- e. Repeat above procedures until all different time-slot modes have been completed.

##### 4.4.5 Deviation from Test Standard

No deviation.

### 4.4.6 Test Results

#### GFSK

Mode	Number of transmission in a 31.6 (79 Hopping*0.4)	Length of transmission time (msec)	Result (msec)	Limit (sec)
DH1	51 (times / 5 sec) * 6.32 = 322.32 times	0.423	136.34	0.4
DH3	26 (times / 5 sec) * 6.32 = 164.32 times	1.674	275.07	0.4
DH5	17 (times / 5 sec) * 6.32 = 107.44 times	2.94	315.87	0.4

**Note:** Test plots of the transmitting time slot are shown as below.

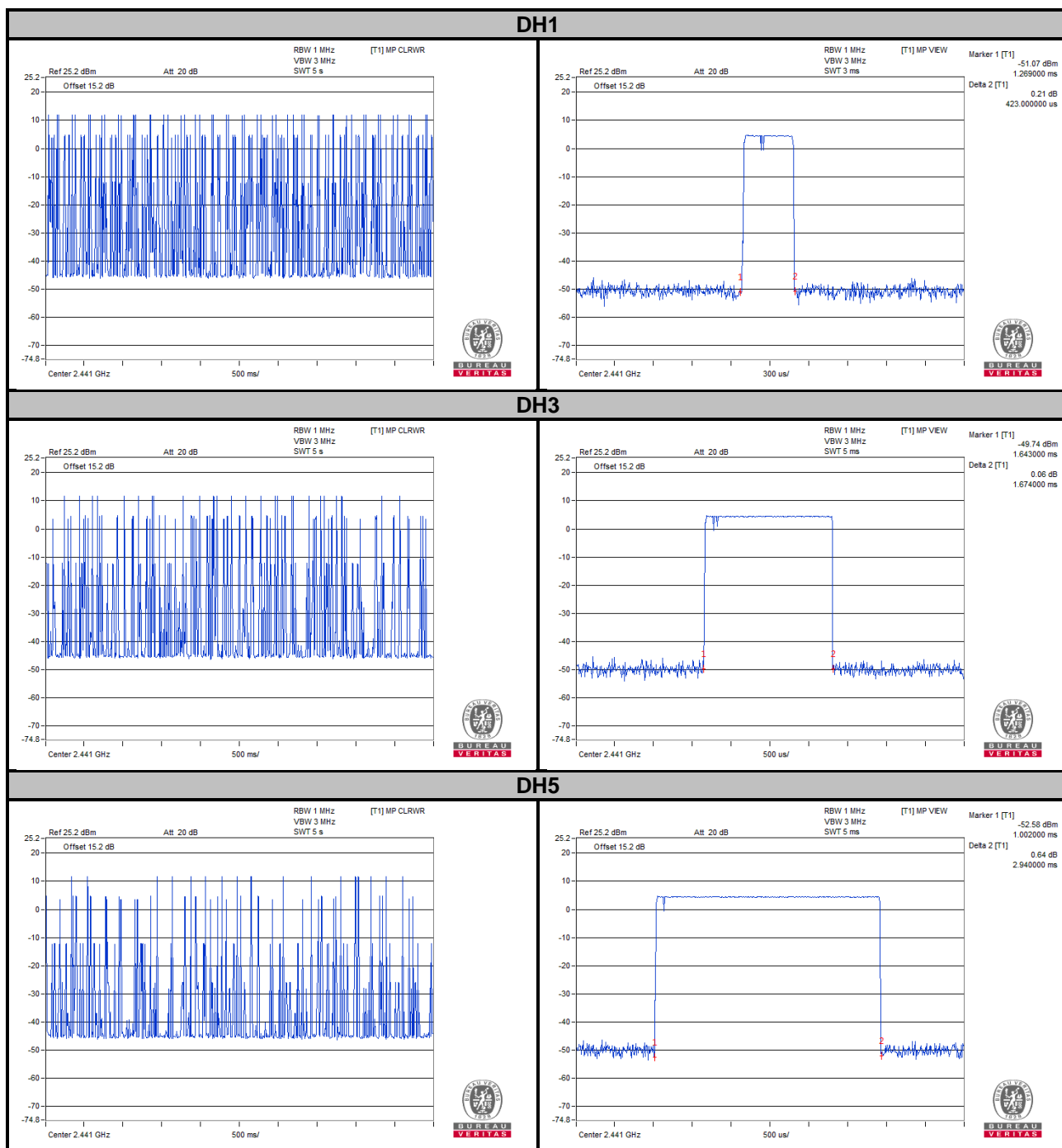

**π/4-DQPSK**

Mode	Number of transmission in a 31.6 (79 Hopping*0.4)	Length of transmission time (msec)	Result (msec)	Limit (sec)
2DH1	50 (times / 5 sec) * 6.32 = 316 times	0.423	133.67	0.4
2DH3	27 (times / 5 sec) * 6.32 = 170.64 times	1.707	291.28	0.4
2DH5	18 (times / 5 sec) * 6.32 = 113.76 times	2.925	332.75	0.4

**Note:** Test plots of the transmitting time slot are shown as below.

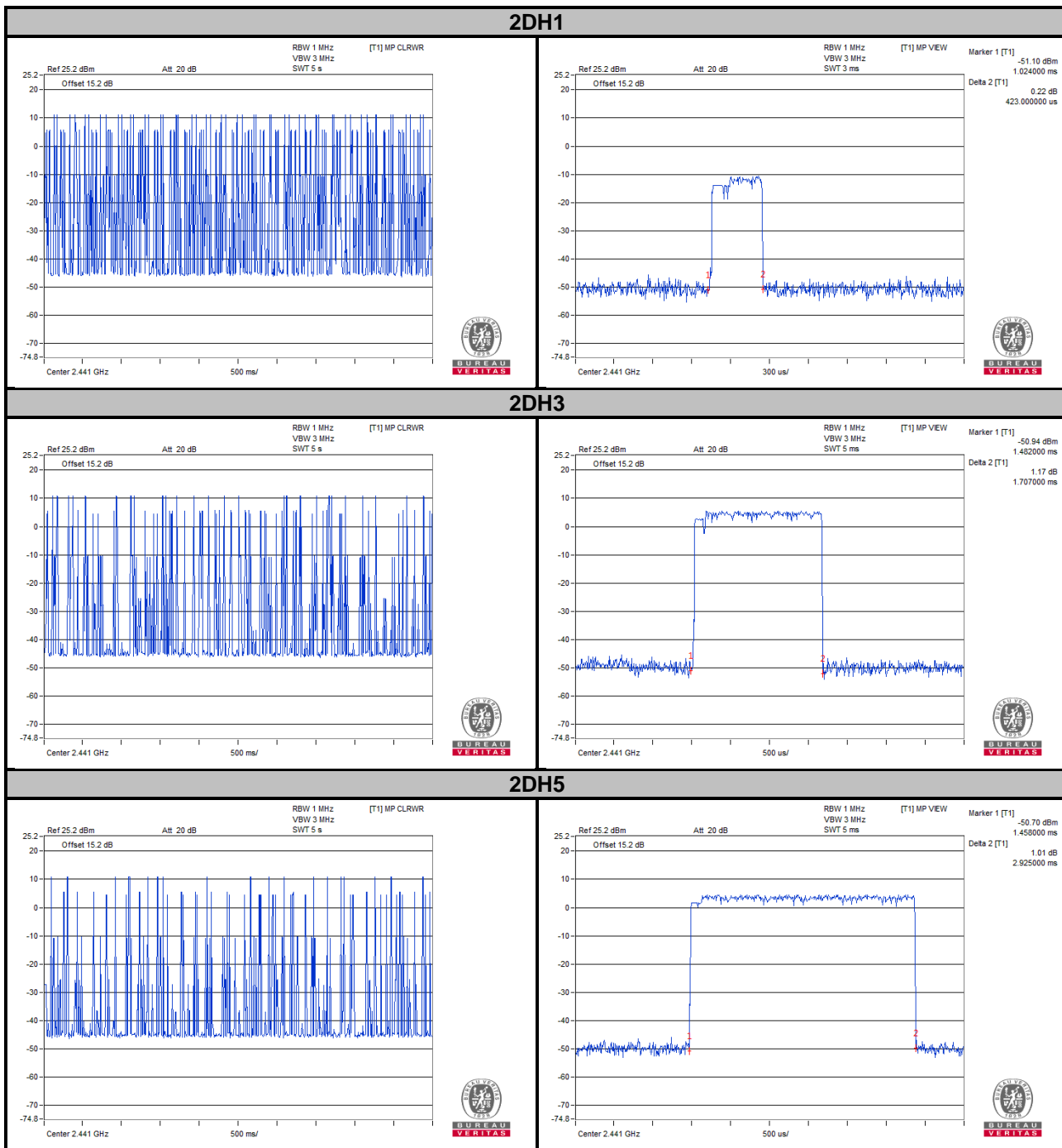

### 8DPSK

Mode	Number of transmission in a 31.6 (79 Hopping*0.4)	Length of transmission time (msec)	Result (msec)	Limit (sec)
3DH1	50 (times / 5 sec) * 6.32 = 316 times	0.437	138.09	0.4
3DH3	27 (times / 5 sec) * 6.32 = 170.64 times	1.682	287.02	0.4
3DH5	18 (times / 5 sec) * 6.32 = 113.76 times	2.932	333.54	0.4

**Note:** Test plots of the transmitting time slot are shown as below.

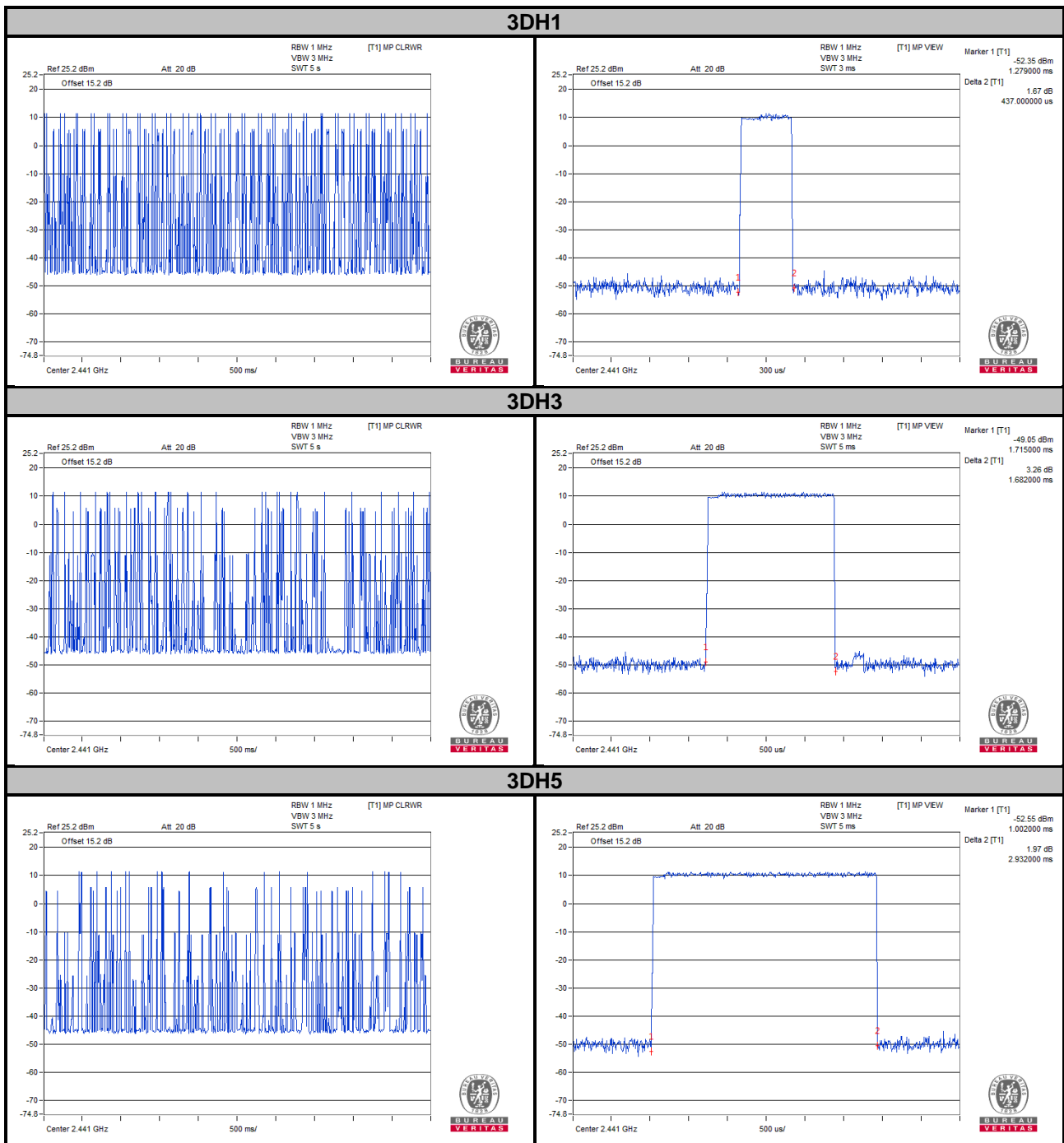

## 4.5 Channel Bandwidth

### 4.5.1 Limits of Channel Bandwidth Measurement

For frequency hopping system operating in the 2400-2483.5 MHz, if the 20 dB bandwidth of hopping channel is greater than 25 kHz, two-thirds 20 dB bandwidth of hopping channel shall be a minimum limit for the hopping channel separation.

### 4.5.2 Test Setup

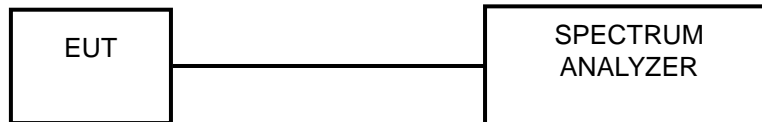

### 4.5.3 Test Instruments

Refer to section 4.1.2 to get information of above instrument.

### 4.5.4 Test Procedure

- a. Check the calibration of the measuring instrument using either an internal calibrator or a known signal from an external generator.
- b. Turn on the EUT and connect it to measurement instrument. Then set it to any one convenient frequency within its operating range. Set a reference level on the measuring instrument equal to the highest peak value.
- c. Measure the frequency difference of two frequencies that were attenuated 20 dB from the reference level. Record the frequency difference as the emission bandwidth.
- d. Repeat above procedures until all frequencies measured were complete.

### 4.5.5 Deviation from Test Standard

No deviation.

### 4.5.6 EUT Operating Condition

The software provided by client enabled the EUT to transmit and receive data at lowest, middle and highest channel frequencies individually.

### 4.5.7 Test Results

Channel	Frequency (MHz)	20 dB Bandwidth (MHz)		
		GFSK	$\pi/4$ -DQPSK	8DPSK
0	2402	0.89	1.28	1.24
39	2441	0.94	1.30	1.24
78	2480	0.94	1.30	1.24

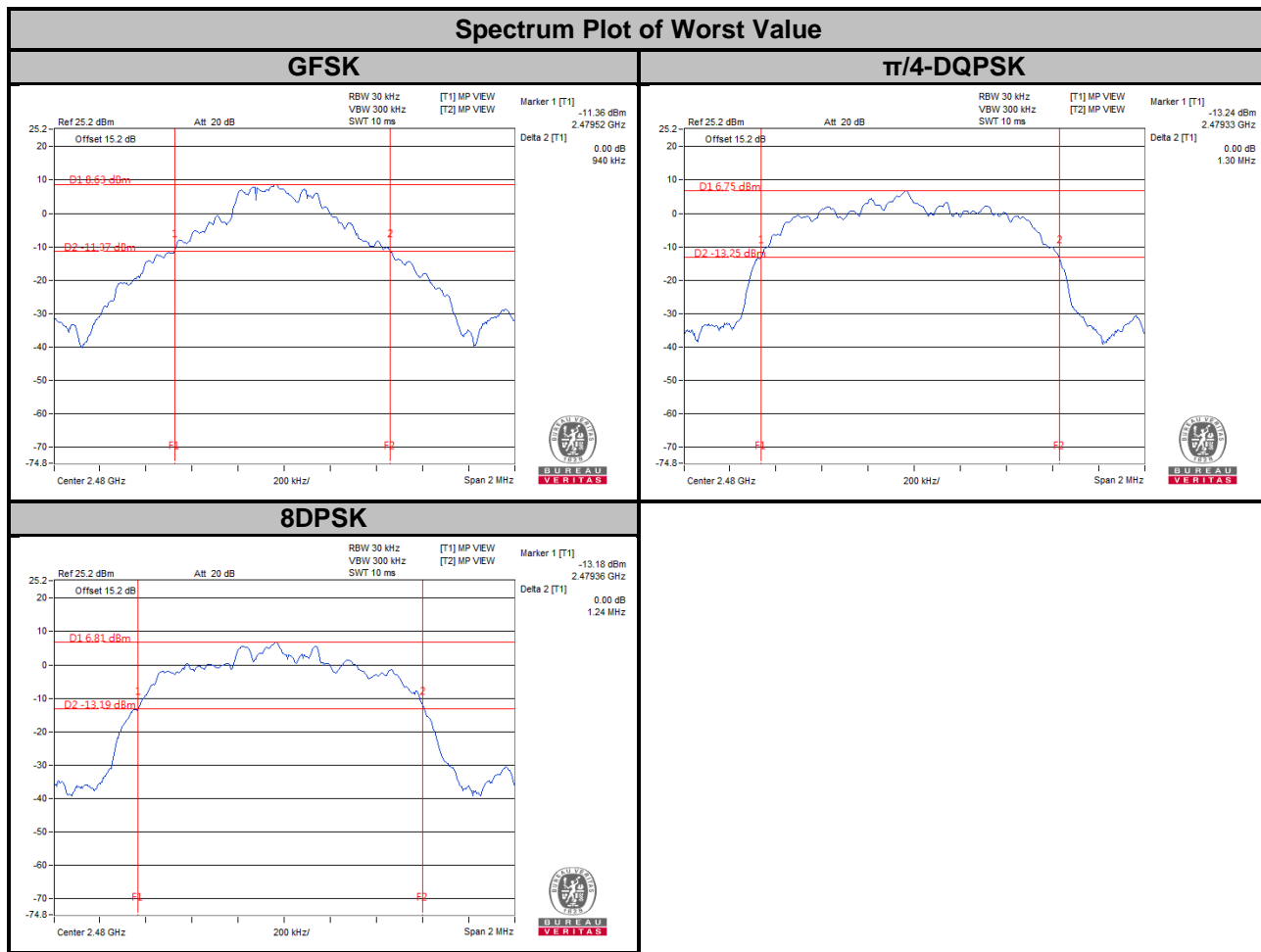

## 4.6 Hopping Channel Separation

### 4.6.1 Limits of Hopping Channel Separation Measurement

At least 25 kHz or two-third of 20 dB hopping channel bandwidth (whichever is greater).

### 4.6.2 Test Setup

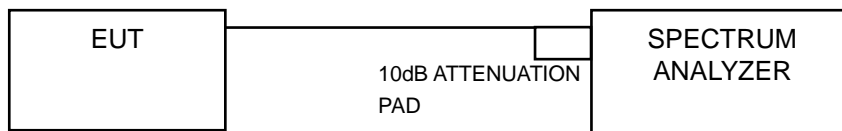

### 4.6.3 Test Instruments

Refer to section 4.1.2 to get information of above instrument.

### 4.6.4 Test Procedure

#### Measurement Procedure REF

- Check the calibration of the measuring instrument using either an internal calibrator or a known signal from an external generator.
- Turn on the EUT and connect it to measurement instrument. Then set it to any one convenient frequency within its operating range.
- By using the MaxHold function record the separation of two adjacent channels.
- Measure the frequency difference of these two adjacent channels by SA MARK function. And then plot the result on SA screen.
- Repeat above procedures until all frequencies measured were complete.

### 4.6.5 Deviation from Test Standard

No deviation.

#### 4.6.6 Test Results

Channel	Freq. (MHz)	Adjacent Channel Separation (MHz)			20 dB Bandwidth (MHz)			Minimum Limit (MHz)			Pass / Fail
		GFSK	$\pi/4$ -DQPSK	8DPSK	GFSK	$\pi/4$ -DQPSK	8DPSK	GFSK	$\pi/4$ -DQPSK	8DPSK	
0	2402	1.00	1.00	1.00	0.89	1.28	1.24	0.6	0.86	0.83	Pass
39	2441	1.00	1.00	1.00	0.94	1.30	1.24	0.63	0.87	0.83	Pass
78	2480	1.00	1.00	1.00	0.94	1.30	1.24	0.63	0.87	0.83	Pass

**Note:**

- The minimum limit is two-third 20 dB bandwidth.

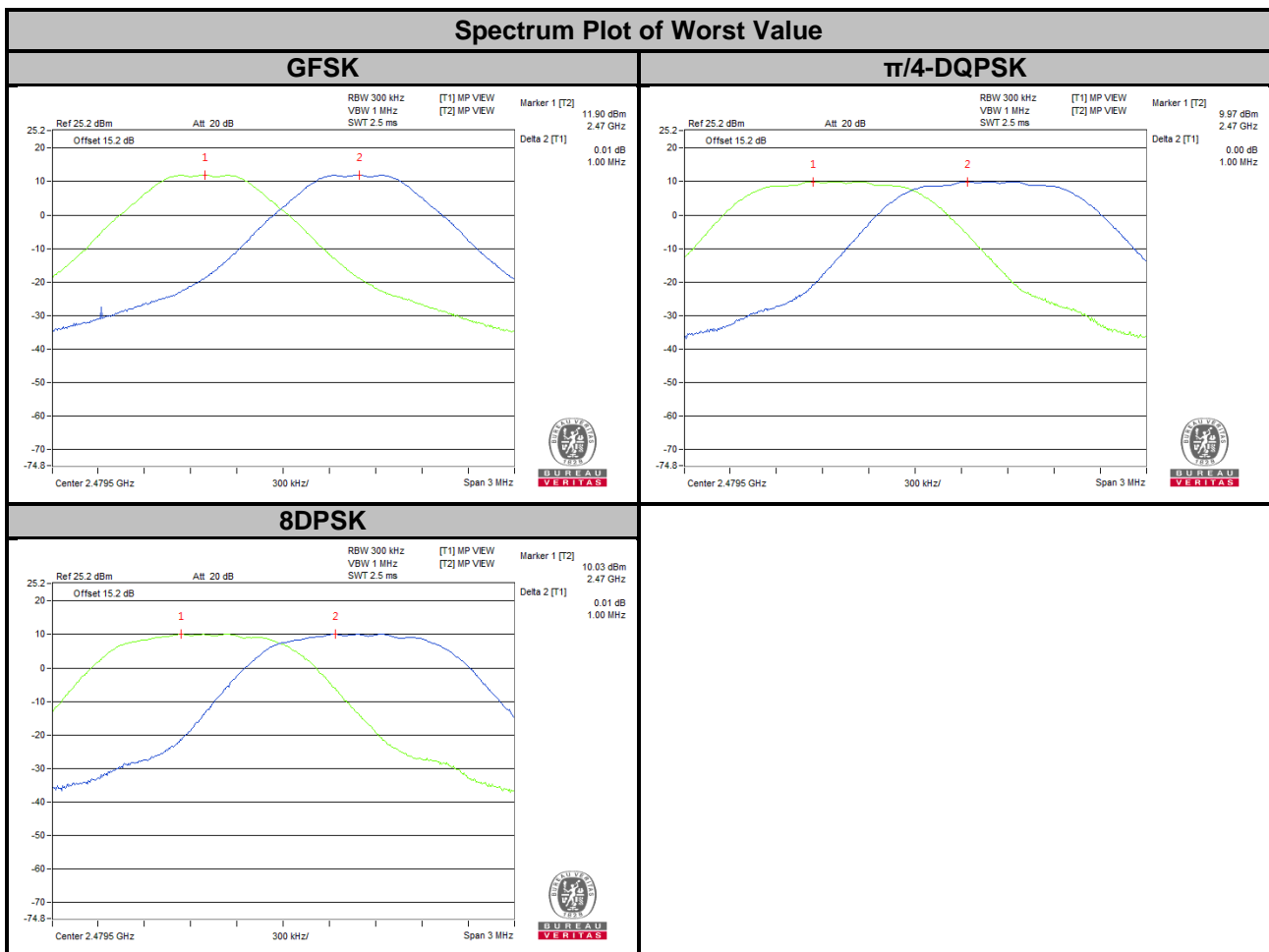



## 4.7 Maximum Output Power

### 4.7.1 Limits of Maximum Output Power Measurement

The Maximum Output Power Measurement is 125 mW.

### 4.7.2 Test Setup

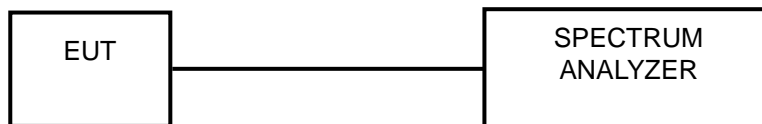

### 4.7.3 Test Instruments

Refer to section 4.1.2 to get information of above instrument.

### 4.7.4 Test Procedure

- Check the calibration of the measuring instrument using either an internal calibrator or a known signal from an external generator.
- Turn on the EUT and connect it to measurement instrument. Then set it to any one convenient frequency within its operating range. Set a reference level on the measuring instrument equal to the highest peak value.
- The center frequency of the spectrum analyzer is set to the fundamental frequency and using 3 MHz RBW and 10 MHz VBW.
- Measure the captured power within the band and recording the plot.
- Repeat above procedures until all frequencies required were complete.

### 4.7.5 Deviation from Test Standard

No deviation.

### 4.7.6 EUT Operating Condition

The software provided by client enabled the EUT to transmit and receive data at lowest, middle and highest channel frequencies individually.

### 4.7.7 Test Results

Channel	Freq. (MHz)	Output Power (mW)			Output Power (dBm)			Power Limit (mW)	Pass / Fail
		GFSK	$\pi/4$ -DQPSK	8DPSK	GFSK	$\pi/4$ -DQPSK	8DPSK		
0	2402	17.458	16.866	18.155	12.42	12.27	12.59	125	Pass
39	2441	17.100	16.634	17.783	12.33	12.21	12.50	125	Pass
78	2480	16.866	16.331	17.539	12.27	12.13	12.44	125	Pass

### Spectrum Plot of Worst Value

#### GFSK

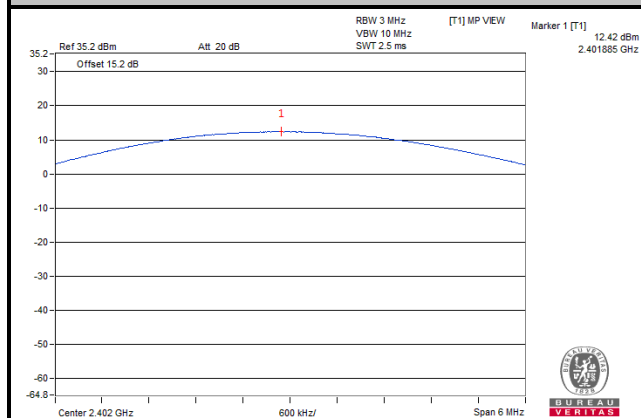

#### $\pi/4$ -DQPSK

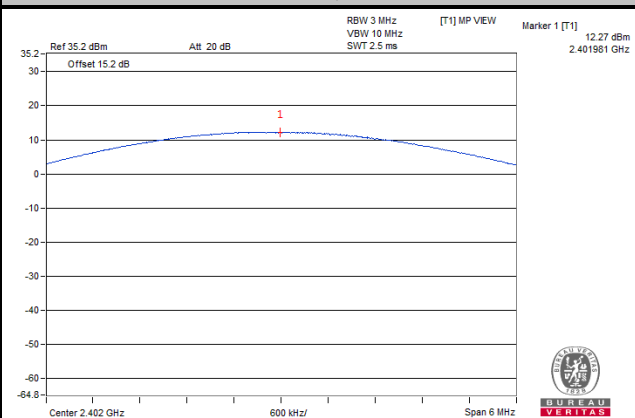

#### 8DPSK

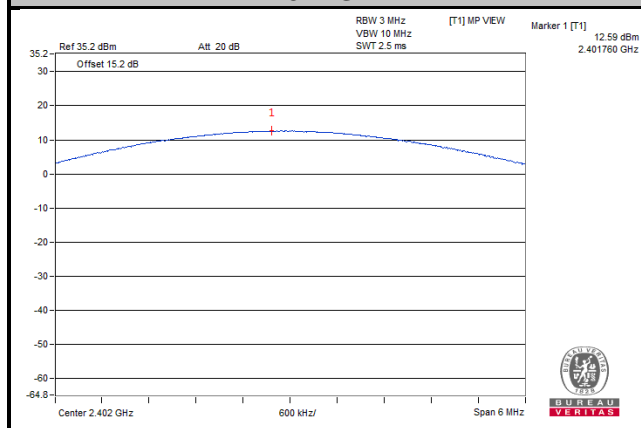

## 4.8 Conducted Out of Band Emission Measurement

### 4.8.1 Limits Of Conducted Out Of Band Emission Measurement

Below  $-20$  dB of the highest emission level of operating band (in 100 kHz RBW).

### 4.8.2 Test Instruments

Refer to section 4.1.2 to get information of above instrument.

### 4.8.3 Test Procedure

The transmitter output was connected to the spectrum analyzer via a low lose cable. Set both RBW and VBW of spectrum analyzer to 100 kHz and 300 kHz with suitable frequency span including 100 MHz bandwidth from band edge. The band edges was measured and recorded.

### 4.8.4 Deviation from Test Standard

No deviation.

### 4.8.5 EUT Operating Condition

The software provided by client enabled the EUT to transmit and receive data at lowest, middle and highest channel frequencies individually.

### 4.8.6 Test Results

The spectrum plots are attached on the following images. D1 line indicates the highest level, D2 line indicates the 20 dB offset below D1. It shows compliance with the requirement.

GFSK

Hopping Disabled\_Low Channel

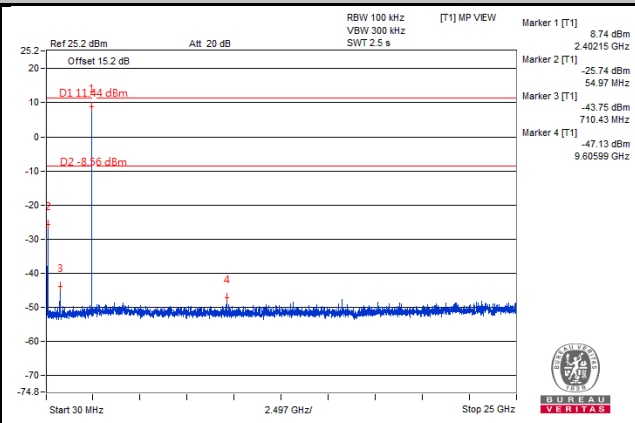
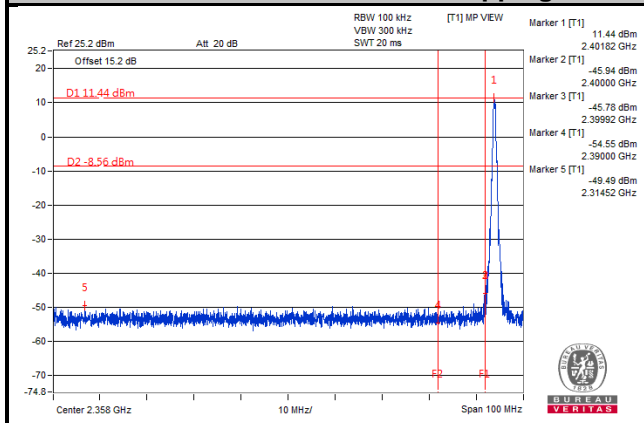

Hopping Disabled\_High Channel

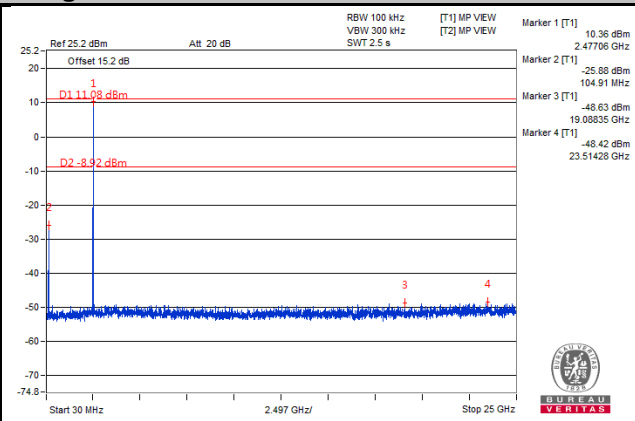
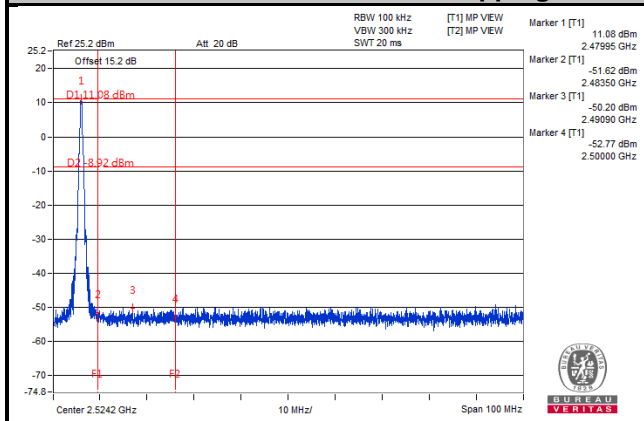

Hopping Disabled\_Middle Channel

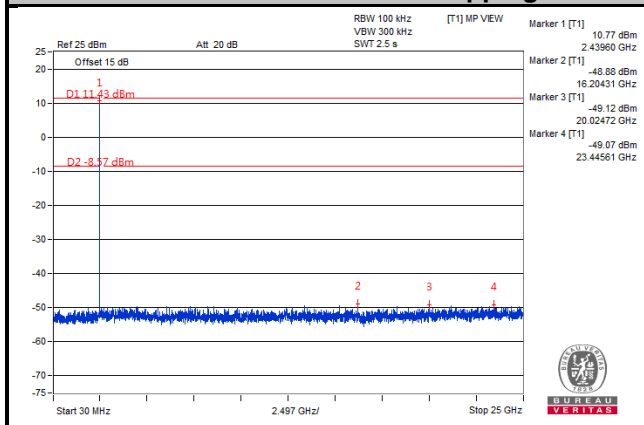

### Hopping Enabled\_Low Channel

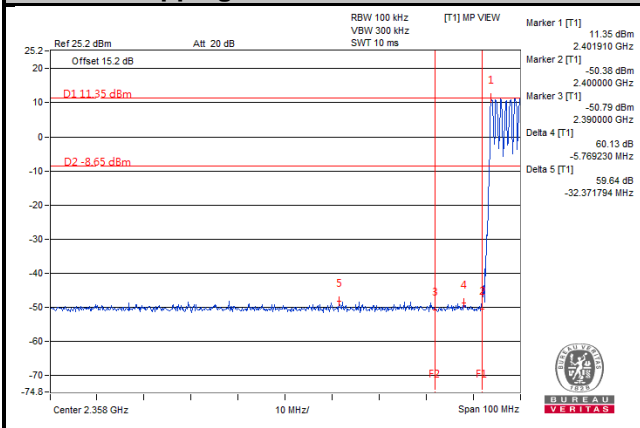

### Hopping Enabled\_High Channel

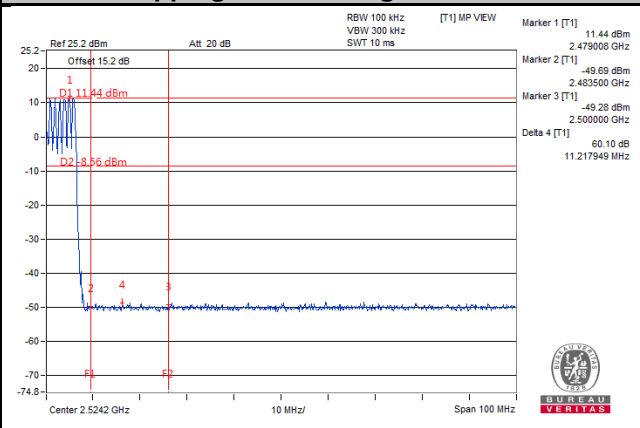

$\pi/4$ -DQPSK

Hopping Disabled\_Low Channel

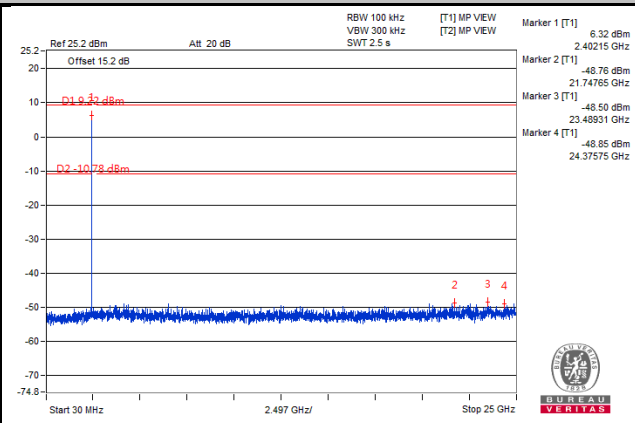
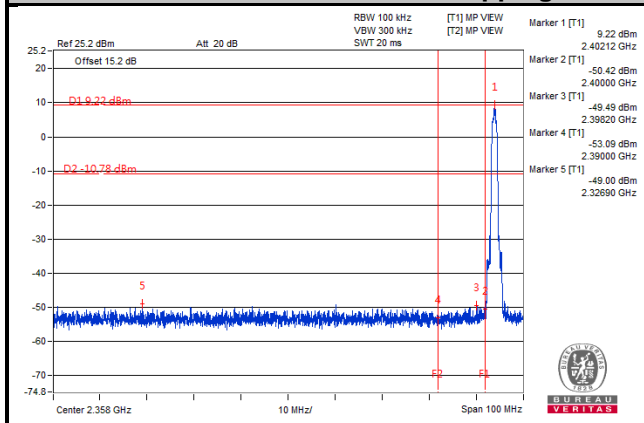

Hopping Disabled\_High Channel

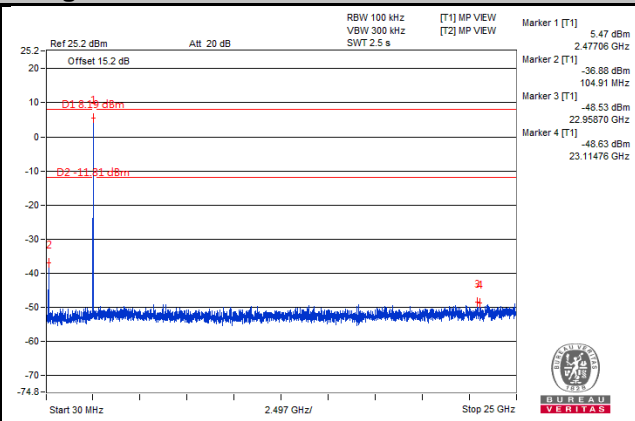
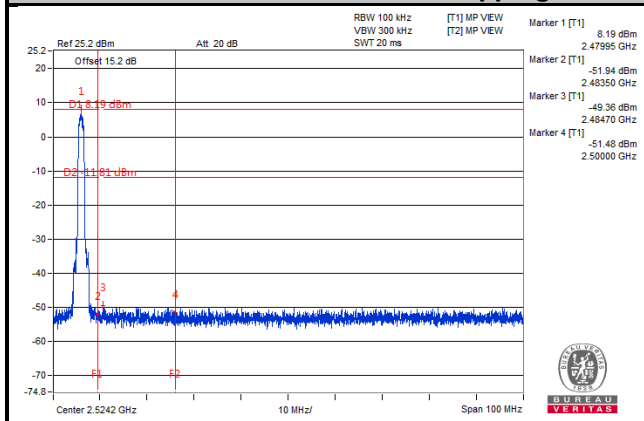

Hopping Disabled\_Middle Channel

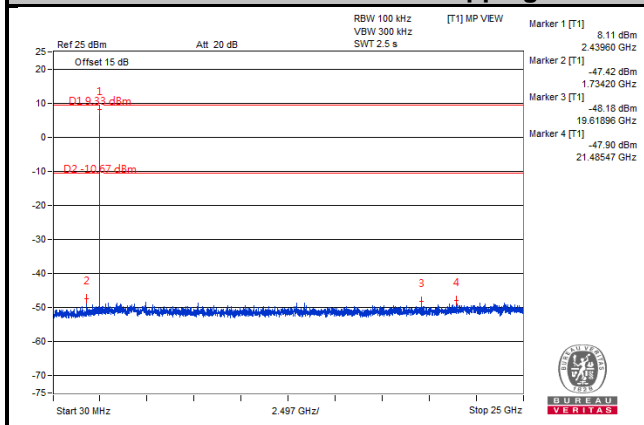

### Hopping Enabled\_Low Channel

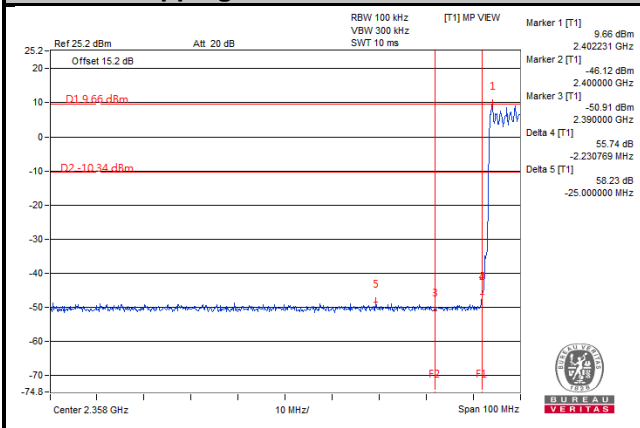

### Hopping Enabled\_Low Channel

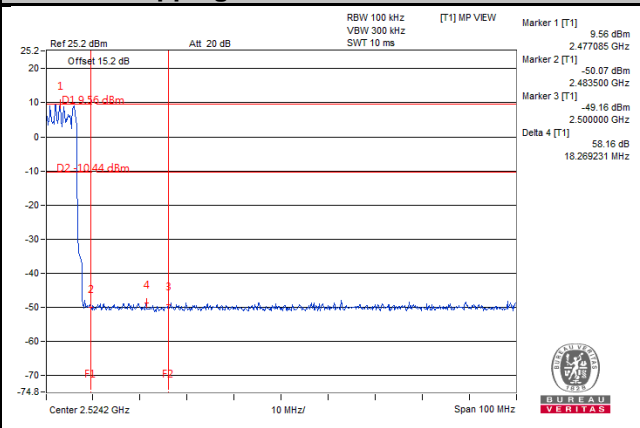

# 8DPSK

## Hopping Disabled\_Low Channel

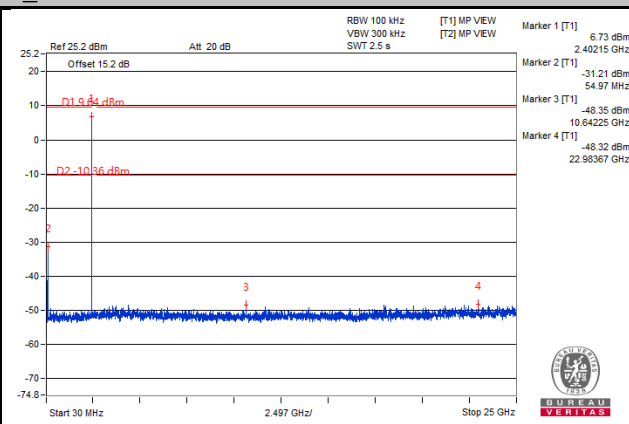
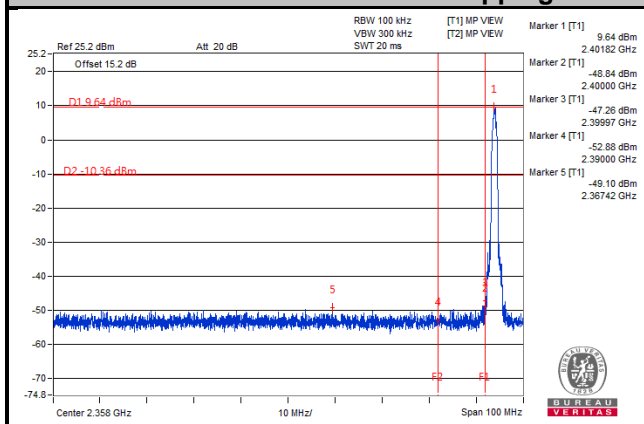

## Hopping Disabled\_High Channel

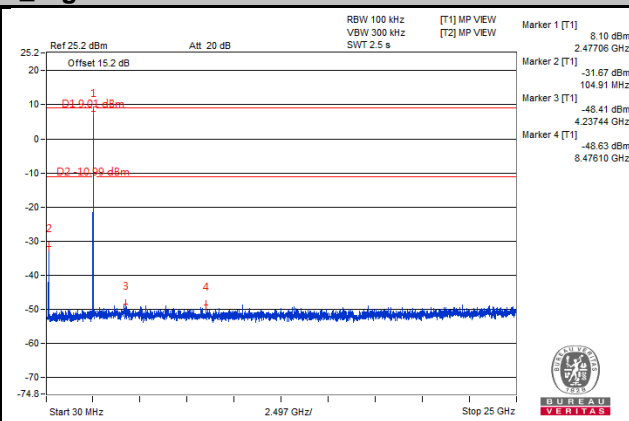
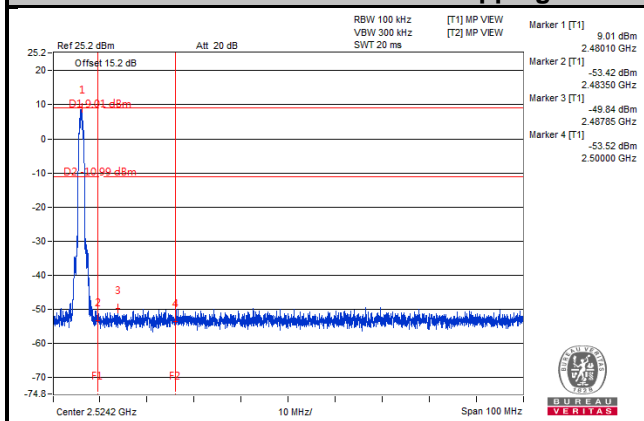

## Hopping Disabled\_Middle Channel

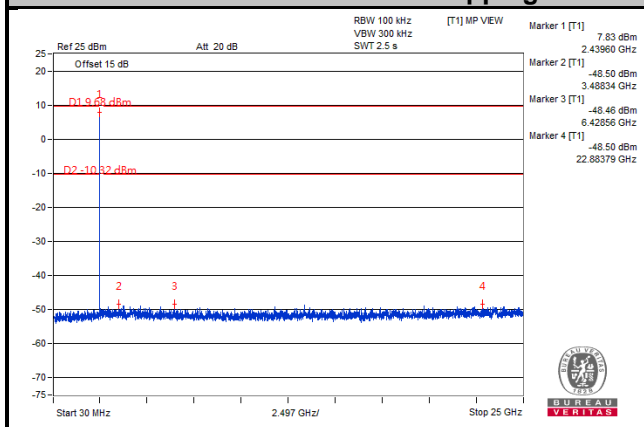



### Hopping Enabled\_Low Channel

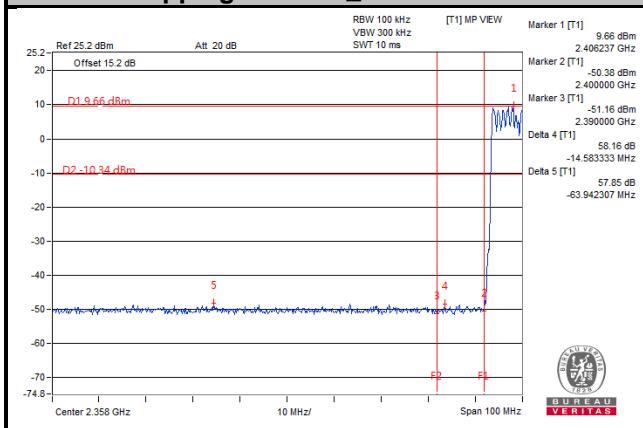

### Hopping Enabled\_Low Channel

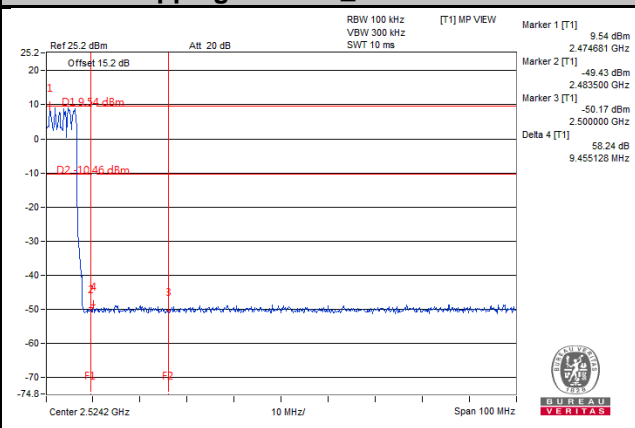

## 5 Pictures of Test Arrangements

Please refer to the attached file (Test Setup Photo).

## Appendix – Information on the Testing Laboratories

We, Bureau Veritas Consumer Products Services (H.K.) Ltd., Taoyuan Branch, were founded in 1988 to provide our best service in EMC, Radio, Telecom and Safety consultation. Our laboratories are accredited and approved according to ISO/IEC 17025.

If you have any comments, please feel free to contact us at the following:

**Linko EMC/RF Lab**

Tel: 886-2-26052180

Fax: 886-2-26051924

**Hsin Chu EMC/RF/Telecom Lab**

Tel: 886-3-6668565

Fax: 886-3-6668323

**Hwa Ya EMC/RF/Safety**

Tel: 886-3-3183232

Fax: 886-3-3270892

**Email:** [service.adt@tw.bureauveritas.com](mailto:service.adt@tw.bureauveritas.com)

**Web Site:** [www.bureauveritas-adt.com](http://www.bureauveritas-adt.com)

The address and road map of all our labs can be found in our web site also.

--- END ---