



RADIO TEST REPORT

Test Report No. : 11394939H-A-R1

Applicant : MITSUBISHI ELECTRIC CORPORATION SANDA WORKS

Type of Equipment : HEADUNIT A-ENTRY

Model No. : NTG5.5HUE

FCC ID : UJHNTG55HUE

Test regulation : FCC Part 15 Subpart C: 2016 (WLAN Part)

Test Result : Complied

1. This test report shall not be reproduced in full or partial, without the written approval of UL Japan, Inc.
2. The results in this report apply only to the sample tested.
3. This sample tested is in compliance with the above regulation.
4. The test results in this report are traceable to the national or international standards.
5. This test report must not be used by the customer to claim product certification, approval, or endorsement by NVLAP, NIST, or any agency of the Federal Government.
6. This test report covers Radio technical requirements. It does not cover administrative issues such as Manual or non-Radio test related Requirements. (if applicable)
7. This report is a revised version of 11394939H-A. 11394939H-A is replaced with this report.

Date of test: August 4 to 24, 2016

Representative test engineer:

Hiroyuki Furutaka

Engineer
Consumer Technology Division

Approved by:

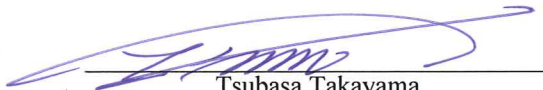

Tsubasa Takayama
Engineer
Consumer Technology Division



NVLAP LAB CODE: 200572-0

This laboratory is accredited by the NVLAP LAB CODE 200572-0, U.S.A. The tests reported herein have been performed in accordance with its terms of accreditation. *As for the range of Accreditation in NVLAP, you may refer to the WEB address, http://japan.ul.com/resources/emc_accredited/

UL Japan, Inc.

Ise EMC Lab.

4383-326 Asama-cho, Ise-shi, Mie-ken 516-0021 JAPAN

Telephone : +81 596 24 8999

Facsimile : +81 596 24 8124

13-EM-F0429

CONTENTS	PAGE
SECTION 1: Customer information.....	4
SECTION 2: Equipment under test (E.U.T.).....	4
SECTION 3: Test specification, procedures & results.....	5
SECTION 4: Operation of E.U.T. during testing.....	8
SECTION 5: Radiated Spurious Emission	11
SECTION 6: Antenna Terminal Conducted Tests.....	13
APPENDIX 1: Test data	14
6dB Bandwidth	14
Maximum Peak Output Power	17
Average Output Power	20
Radiated Spurious Emission	23
Conducted Spurious Emission	34
Power Density	35
99%Occupied Bandwidth	38
APPENDIX 2: Test instruments	40
APPENDIX 3: Photographs of test setup	41
Radiated Spurious Emission	41
Worst Case Position	42

SECTION 1: Customer information

Company Name : MITSUBISHI ELECTRIC CORPORATION SANDA WORKS
Address : 2-3-33, Miwa, Sanda-city, Hyogo, 669-1513, Japan
Telephone Number : +81-79-559-3607
Facsimile Number : +81-79-559-3875
Contact Person : Harutaka Nomura

SECTION 2: Equipment under test (E.U.T.)

2.1 Identification of E.U.T.

Type of Equipment : HEADUNIT A-ENTRY
Model No. : NTG5.5HUE
Serial No. : Refer to Section 4, Clause 4.2
Rating : DC 12 V
Receipt Date of Sample : August 1, 2016
Country of Mass-production : Thailand
Condition of EUT : Production prototype
(Not for Sale: This sample is equivalent to mass-produced items.)
Modification of EUT : No Modification by the test lab

2.2 Product Description

Model: NTG5.5HUE (referred to as the EUT in this report) is a HEADUNIT A-ENTRY.

General Specification

Clock frequency(ies) in the system : 1.4 GHz, 40 MHz, 26 MHz

Radio Specification

	IEEE802.11b	IEEE802.11g/n (20 M band)	Bluetooth Ver.3.0 with EDR function
Frequency of operation	2412 MHz - 2462 MHz *1)	2412 MHz - 2462 MHz *1)	2402 MHz - 2480 MHz
Type of modulation	DSSS (CCK, DQPSK, DBPSK)	OFDM-CCK (64QAM, 16QAM, QPSK, BPSK)	FHSS (GFSK, $\pi/4$ -DQPSK, 8-DPSK)
Channel spacing	5 MHz		1 MHz
Antenna type	Printed patch Antenna		
Antenna Connector type	FAKRA		PSE-LP2
Antenna Gain	3.3 dBi		2.32 dBi

*1) This test report applies for WLAN (IEEE802.11b/g/n-20 [2412-2462MHz]).

	GPS/GLONASS
Frequency of operation	GPS: 1575.42 MHz GLONASS: 1597.55-1605.89 MHz
Type of modulation	GPS: BPSK GLONASS: BPSK
Channel spacing	GLONASS: 0.5625 MHz
Antenna type	Active antenna
Antenna Connector type	FAKRA
Antenna Gain	25 dBi

UL Japan, Inc.

Ise EMC Lab.

4383-326 Asama-cho, Ise-shi, Mie-ken 516-0021 JAPAN

Telephone : +81 596 24 8999

Facsimile : +81 596 24 8124

SECTION 3: Test specification, procedures & results

3.1 Test Specification

Test Specification : FCC Part 15 Subpart C
FCC part 15 final revised on April 6, 2016.

Title : FCC 47CFR Part15 Radio Frequency Device Subpart C Intentional Radiators
Section 15.207 Conducted limits
Section 15.247 Operation within the bands 902-928MHz,
2400-2483.5MHz, and 5725-5850MHz

3.2 Procedures and results

Item	Test Procedure	Specification	Worst margin	Results	Remarks
Conducted Emission	FCC: ANSI C63.10-2013 6. Standard test methods ----- IC: RSS-Gen 8.8	FCC: Section 15.207 ----- IC: RSS-Gen 8.8	N/A	N/A *1)	-
6dB Bandwidth	FCC: KDB 558074 D01 DTS Meas Guidance v03r05 ----- IC: -	FCC: Section 15.247(a)(2) ----- IC: RSS-247 5.2(1)	See data.	Complied	Conducted
Maximum Peak Output Power	FCC: KDB 558074 D01 DTS Meas Guidance v03r05 ----- IC: RSS-Gen 6.12	FCC: Section 15.247(b)(3) ----- IC: RSS-247 5.4(4)		Complied	Conducted
Power Density	FCC: KDB 558074 D01 DTS Meas Guidance v03r05 ----- IC: -	FCC: Section 15.247(e) ----- IC: RSS-247 5.2(2)		Complied	Conducted
Spurious Emission Restricted Band Edges	FCC: KDB 558074 D01 DTS Meas Guidance v03r05 ----- IC: RSS-Gen 6.13	FCC: Section15.247(d) ----- IC: RSS-247 5.5 RSS-Gen 8.9 RSS-Gen 8.10	1.6 dB 884.737 MHz, Horizontal, QP	Complied	Conducted (below 30 MHz)/ Radiated (above 30 MHz) *2)

Note: UL Japan, Inc.'s EMI Work Procedures No. 13-EM-W0420 and 13-EM-W0422.

*1) The test is not applicable since the EUT is not the device that is designed to be connected to the public utility (AC) power line.

*2) Radiated test was selected over 30 MHz based on section 15.247(d) and KDB 558074 D01 DTS Meas Guidance v03r05 12.2.7.

* In case any questions arise about test procedure, ANSI C63.10: 2013 is also referred.

FCC 15.31 (e)

The EUT provides stable voltage (DC 3.3 V) constantly to the wireless transmitter regardless of input voltage.

Instead of a new battery, DC power supply was used for the test.

That does not affect the test result, therefore the EUT complies with the requirement.

FCC Part 15.203 Antenna requirement

It is impossible for end users to replace the antenna, because the antenna is mounted inside of the vehicle. Therefore, the equipment complies with the antenna requirement of Section 15.203.

UL Japan, Inc.

Ise EMC Lab.

4383-326 Asama-cho, Ise-shi, Mie-ken 516-0021 JAPAN

Telephone : +81 596 24 8999

Facsimile : +81 596 24 8124

3.3 Addition to standard

Item	Test Procedure	Specification	Worst margin	Results	Remarks
99% Occupied Bandwidth	IC: RSS-Gen 6.6	IC: -	N/A	-	Conducted

Other than above, no addition, exclusion nor deviation has been made from the standard.

3.4 Uncertainty

EMI

The following uncertainties have been calculated to provide a confidence level of 95 % using a coverage factor $k = 2$.
Ise EMC Lab.

Antenna terminal test Uncertainty (+/-)							
Power meter		Conducted emission and Power density			Conducted emission		Channel power
Below 1 GHz	Above 1 GHz	Below 1 GHz	1 GHz -3 GHz	3 GHz -18 GHz	18 GHz -26.5 GHz	26.5 GHz -40 GHz	
0.9 dB	1.0 dB	1.4 dB	1.7 dB	2.8 dB	2.8 dB	2.9 dB	2.6 dB

Test distance	Radiated emission (+/-) 9 kHz - 30 MHz
3m	3.8 dB
10m	3.7 dB

Polarity	Radiated emission (Below 1GHz)			
	(3 m*) (+/-)		(10 m*) (+/-)	
	30 - 200 MHz	200 - 1000MHz	30 - 200 MHz	200 - 1000MHz
Horizontal	5.0 dB	5.3 dB	5.0 dB	5.0 dB
Vertical	4.7 dB	5.9 dB	5.0 dB	5.1 dB

Radiated emission (Above 1GHz)				
(3 m*) (+/-)		(1 m*) (+/-)		(10 m*) (+/-)
1 - 6GHz	6 - 18GHz	10 - 26.5 GHz	26.5 - 40GHz	1 -18 GHz
5.2 dB	5.4 dB	5.5 dB	5.5 dB	5.4 dB

*Measurement distance

Radiated emission test

The data listed in this report meets the limits unless the uncertainty is taken into consideration.

3.5 Test Location

UL Japan, Inc. Ise EMC Lab. *NVLAP Lab. code: 200572-0
4383-326 Asama-cho, Ise-shi, Mie-ken 516-0021 JAPAN
Telephone: +81 596 24 8999, Facsimile: +81 596 24 8124

Test site	IC Registration Number	Width x Depth x Height (m)	Size of reference ground plane (m) / horizontal conducting plane	Other rooms	Maximum measurement distance
No.1 semi-anechoic chamber	2973C-1	19.2 x 11.2 x 7.7	7.0 x 6.0	No.1 Power source room	10 m
No.2 semi-anechoic chamber	2973C-2	7.5 x 5.8 x 5.2	4.0 x 4.0	-	3 m
No.3 semi-anechoic chamber	2973C-3	12.0 x 8.5 x 5.9	6.8 x 5.75	No.3 Preparation room	3 m
No.3 shielded room	-	4.0 x 6.0 x 2.7	N/A	-	-
No.4 semi-anechoic chamber	2973C-4	12.0 x 8.5 x 5.9	6.8 x 5.75	No.4 Preparation room	3 m
No.4 shielded room	-	4.0 x 6.0 x 2.7	N/A	-	-
No.5 semi-anechoic chamber	-	6.0 x 6.0 x 3.9	6.0 x 6.0	-	-
No.6 shielded room	-	4.0 x 4.5 x 2.7	4.0 x 4.5	-	-
No.6 measurement room	-	4.75 x 5.4 x 3.0	4.75 x 4.15	-	-
No.7 shielded room	-	4.7 x 7.5 x 2.7	4.7 x 7.5	-	-
No.8 measurement room	-	3.1 x 5.0 x 2.7	N/A	-	-
No.9 measurement room	-	8.8 x 4.6 x 2.8	2.4 x 2.4	-	-
No.11 measurement room	-	6.2 x 4.7 x 3.0	4.8 x 4.6	-	-

* Size of vertical conducting plane (for Conducted Emission test) : 2.0 m x 2.0m for No.1, No.2, No.3, and No.4 semi-anechoic chambers and No.3 and No.4 shielded rooms.

3.6 Test data, Test instruments, and Test set up

Refer to APPENDIX.

UL Japan, Inc.

Ise EMC Lab.

4383-326 Asama-cho, Ise-shi, Mie-ken 516-0021 JAPAN

Telephone : +81 596 24 8999

Facsimile : +81 596 24 8124

SECTION 4: Operation of E.U.T. during testing

4.1 Operating Mode(s)

Test operating mode was determined as follows according to “Section 1 of 6 802.11 a/b/g/n testing - Managing Complex Regulatory Approvals - ” of TCB Council Workshop October 2009.

Mode	Remarks*
IEEE 802.11b (11b)	1 Mbps, PN9
IEEE 802.11g (11g)	48 Mbps, PN9
IEEE 802.11n 20 MHz BW (11n-20)	MCS 0 (Long GI, 3 Streams), PN9
*The worst condition was determined based on the test result of Maximum Peak Output Power (Mid Channel)	
*Power of the EUT was set by the software as follows; - Power Setting: default - Software: E162.0 *This setting of software is the worst case. Any conditions under the normal use do not exceed the condition of setting. In addition, end users cannot change the settings of the output power of the product.	

*The details of Operating mode(s)

Test Item	Operating Mode	Tested frequency
Radiated Spurious Emission (Below 1GHz)	11n-20 Tx *1)	2462 MHz *1)
Radiated Spurious Emission (Above 1GHz)	11b Tx 11n-20 Tx *2)	2412 MHz 2437 MHz 2462 MHz
Conducted Spurious Emission	11n-20 Tx *1)	2462 MHz *1)
6dB Bandwidth, Maximum Peak Output Power, Average Output Power, Power Density, 99% Occupied Bandwidth	11b Tx 11g Tx 11n-20 Tx	2412 MHz 2437 MHz 2462 MHz

*1) The operating mode and tested frequency were tested as a representative, because it had the highest power at antenna terminal test.

*2) Since 11g and 11n-20 have the same modulation method and no differences in transmitting specification, test was performed on the representative mode that had the highest peak output power.

4.2 Configuration and peripherals

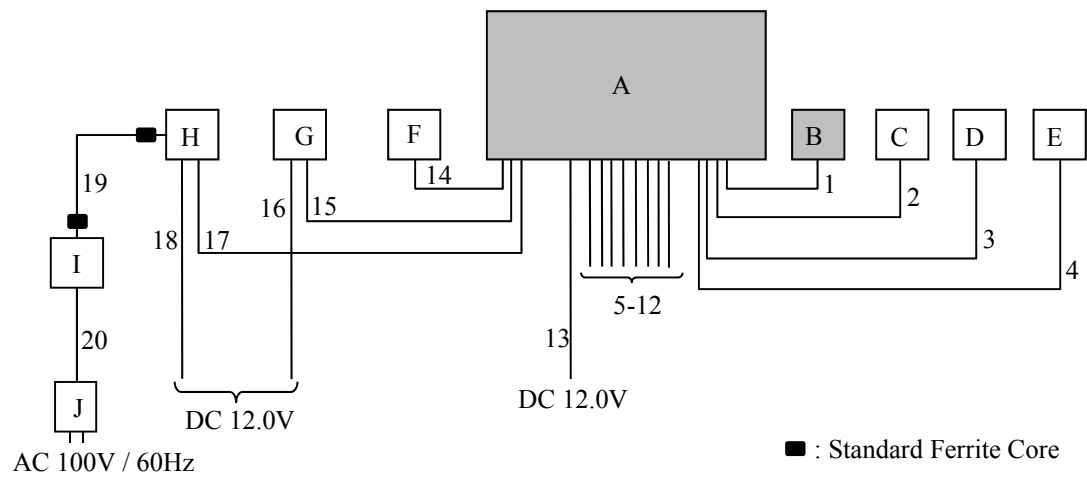

* Cabling and setup(s) were taken into consideration and test data was taken under worse case conditions.

Description of EUT and Support equipment

No.	Item	Model number	Serial number	Manufacturer	Remarks
A	HEADUNIT A-ENTRY	NTG5.5HUE	MED260G5237 070	mitsubishi electric corporation sanda works	EUT
B	WLAN Antenna	AG201-002	ZGS001	WiSi	EUT
C	BT Antenna	050 978-A	23/13	WiSi	-
D	GPS Antenna	-	-	mitsubishi electric corporation sanda works	-
E	USB Memory	PD-07 WH8GB	-	KINGMAX	-
F	Dummy Load	-	-	mitsubishi electric corporation sanda works	-
G	Controller	A 166 900 65 14	4445	Mercedes-Benz	-
H	HSVL Converter	-	-	mitsubishi electric corporation sanda works	-
I	Display	LCD-8000VH	1504U-09	Century	-
J	Switching Power Supply	UWP305S-0510 BC	1503-0000401	UNIWAYPO	-

List of cables used

No.	Name	Length (m)	Shield		Remarks
			Cable	Connector	
1	WLAN Antenna Cable	1.5	Shielded	Shielded	-
2	BT Antenna Cable	0.5	Shielded	Shielded	-
3	GPS Antenna Cable	5.0	Shielded	Shielded	-
4	USB Cable	1.0	Shielded	Shielded	-
5	USB Cable	1.0	Shielded	Shielded	-
6	Dummy Cable	1.0	Shielded	Shielded	-
7	Dummy Cable	1.0	Shielded	Shielded	-
8	Dummy Cable	1.0	Shielded	Shielded	-
9	Dummy Cable	1.0	Shielded	Shielded	-
10	Dummy Cable	1.0	Shielded	Shielded	-
11	LVDS Cable	1.0	Shielded	Shielded	-
12	Signal Cable	1.0	Unshielded	Unshielded	-
13	DC Cable	3.5	Unshielded	Unshielded	-
14	Speaker Cable	0.5	Unshielded	Unshielded	-
15	Signal Cable	1.8	Unshielded	Unshielded	-
16	DC Cable	2.0	Unshielded	Unshielded	-
17	LVDS Cable	1.0	Shielded	Shielded	-
18	DC Cable	3.0	Unshielded	Unshielded	-
19	RGB Cable	1.8	Shielded	Shielded	-
20	USB Cable	1.5	Shielded	Shielded	-

UL Japan, Inc.

Ise EMC Lab.

4383-326 Asama-cho, Ise-shi, Mie-ken 516-0021 JAPAN

Telephone : +81 596 24 8999

Facsimile : +81 596 24 8124

SECTION 5: Radiated Spurious Emission

Test Procedure

It was measured based on "11.0 Emissions in non-restricted frequency bands" of "558074 D01 DTS Meas Guidance v03r05".

[For below 1 GHz]

EUT was placed on a urethane platform of nominal size, 0.5 m by 1.0 m, raised 0.8 m above the conducting ground plane. The Radiated Electric Field Strength has been measured in a Semi Anechoic Chamber with a ground plane.

[For above 1 GHz]

EUT was placed on a urethane platform of nominal size, 0.5 m by 0.5 m, raised 1.5 m above the conducting ground plane.

The Radiated Electric Field Strength has been measured in a Semi Anechoic Chamber with absorbent materials lined on a ground plane.

The height of the measuring antenna varied between 1 and 4 m and EUT was rotated a full revolution in order to obtain the maximum value of the electric field strength.

The measurements were performed for both vertical and horizontal antenna polarization with the Test Receiver, or the Spectrum Analyzer.

The measurements were made with the following detector function of the test receiver and the Spectrum analyzer (in linear mode).

The test was made with the detector (RBW/VBW) in the following table.

When using Spectrum analyzer, the test was made with adjusting span to zero by using peak hold.

Test Antennas are used as below;

Frequency	30 MHz to 200 MHz	200 MHz to 1 GHz	Above 1 GHz
Antenna Type	Biconical	Logperiodic	Horn

In any 100 kHz bandwidth outside the restricted band in which the spread spectrum intentional radiator is operating, the radio frequency power that is produced by the intentional radiator confirmed 20 dB below that in the 100 kHz bandwidth within the band that contains the highest level of the desired power, based on a radiated measurement.

20 dBc was applied to the frequency over the limit of FCC 15.209 / Table 4 of RSS-Gen 8.9(IC) and outside the restricted band of FCC15.205 / Table 6 of RSS-Gen 8.10 (IC).

Frequency	Below 1 GHz	Above 1 GHz		20 dBc
Instrument used	Test Receiver	Spectrum Analyzer		Spectrum Analyzer
Detector	QP	PK	AV *1)	PK
IF Bandwidth	BW 120 kHz	RBW: 1 MHz VBW: 3 MHz	Average Power Method: RBW: 1 MHz VBW: 3 MHz Detector: Power Averaging (RMS) Trace: 100 traces If duty cycle was less than 98%, a duty factor was added to the results.	RBW: 100 kHz VBW: 300kHz
Test Distance	3 m	3 m *2) (1 GHz – 10 GHz), 1 m *3) (10 GHz – 26.5GHz)		3 m *2) (1 GHz – 10 GHz), 1 m *3) (10 GHz – 26.5GHz)

*1) Average Power Measurement was performed based on 6.0 & 12.2.5 of "KDB 558074 D01 DTS Meas Guidance v03r05"

*2) Distance Factor: $20 \times \log(4.3 \text{ m} / 3.0 \text{ m}) = 3.13 \text{ dB}$

*3) Distance Factor: $20 \times \log(1.0 \text{ m} / 3.0 \text{ m}) = -9.5 \text{ dB}$

UL Japan, Inc.

Ise EMC Lab.

4383-326 Asama-cho, Ise-shi, Mie-ken 516-0021 JAPAN

Telephone : +81 596 24 8999

Facsimile : +81 596 24 8124

[WLAN antenna]

- The carrier level and noise levels were confirmed at each position of X, Y and Z axes of WLAN antenna to see the position of maximum noise, and the test was made at the position that has the maximum noise.

[HEADUNIT A-ENTRY]

-The test was made on EUT at the normal use position.

The test results and limit are rounded off to one decimal place, so some differences might be observed.

Measurement range : 30 MHz – 26.5 GHz
Test data : APPENDIX
Test result : Pass

UL Japan, Inc.

Ise EMC Lab.

4383-326 Asama-cho, Ise-shi, Mie-ken 516-0021 JAPAN

Telephone : +81 596 24 8999

Facsimile : +81 596 24 8124

SECTION 6: Antenna Terminal Conducted Tests

Test Procedure

The tests were made with below setting connected to the antenna port.

Test	Span	RBW	VBW	Sweep time	Detector	Trace	Instrument used
6dB Bandwidth	20 MHz	100 kHz	300 kHz	Auto	Peak	Max Hold	Spectrum Analyzer
99% Occupied Bandwidth *1)	Enough width to display emission skirts	1 to 5 % of OBW	Three times of RBW	Auto	Peak	Max Hold	Spectrum Analyzer
Maximum Peak Output Power	-	-	-	Auto	Peak/ Average *2)	-	Power Meter (Sensor: 50 MHz BW)
Peak Power Density	1.5 times the 6dB Bandwidth	3 kHz	10 kHz	Auto	Peak	Max Hold	Spectrum Analyzer *3)
Conducted Spurious Emission *4)	9kHz to 150kHz	200 Hz	620 Hz	Auto	Peak	Max Hold	Spectrum Analyzer
	150kHz to 30MHz	9.1 kHz	27 kHz				

*1) Peak hold was applied as Worst-case measurement.

*2) Reference data

*3) Section 10.2 Method PKPSD (peak PSD) of "KDB 558074 D01 DTS Meas Guidance v03r05".

*4) In the frequency range below 30MHz, RBW was narrowed to separate the noise contents.

Then, wide-band noise near the limit was checked separately, however the noise was low enough as shown in the chart.
(9 kHz - 150 kHz: RBW = 200 Hz, 150 kHz - 30 MHz: RBW = 9.1 kHz).

The test results and limit are rounded off to two decimals place, so some differences might be observed.

Test data : APPENDIX
Test result : Pass

UL Japan, Inc.

Ise EMC Lab.

4383-326 Asama-cho, Ise-shi, Mie-ken 516-0021 JAPAN

Telephone : +81 596 24 8999

Facsimile : +81 596 24 8124

APPENDIX 1: Test data

6dB Bandwidth

Test place Ise EMC Lab. No.6 Measurement Room
Report No. 11394939H
Date August 4, 2016
Temperature / Humidity 23 deg. C / 51 % RH
Engineer Hiroyuki Furutaka
Mode Tx

Mode	Frequency [MHz]	6dB Bandwidth [MHz]	Limit [kHz]
11b	2412	10.097	> 500
	2437	10.096	> 500
	2462	10.088	> 500
11g	2412	16.369	> 500
	2437	16.377	> 500
	2462	16.302	> 500
11n-20	2412	16.292	> 500
	2437	16.320	> 500
	2462	15.918	> 500

6dB Bandwidth

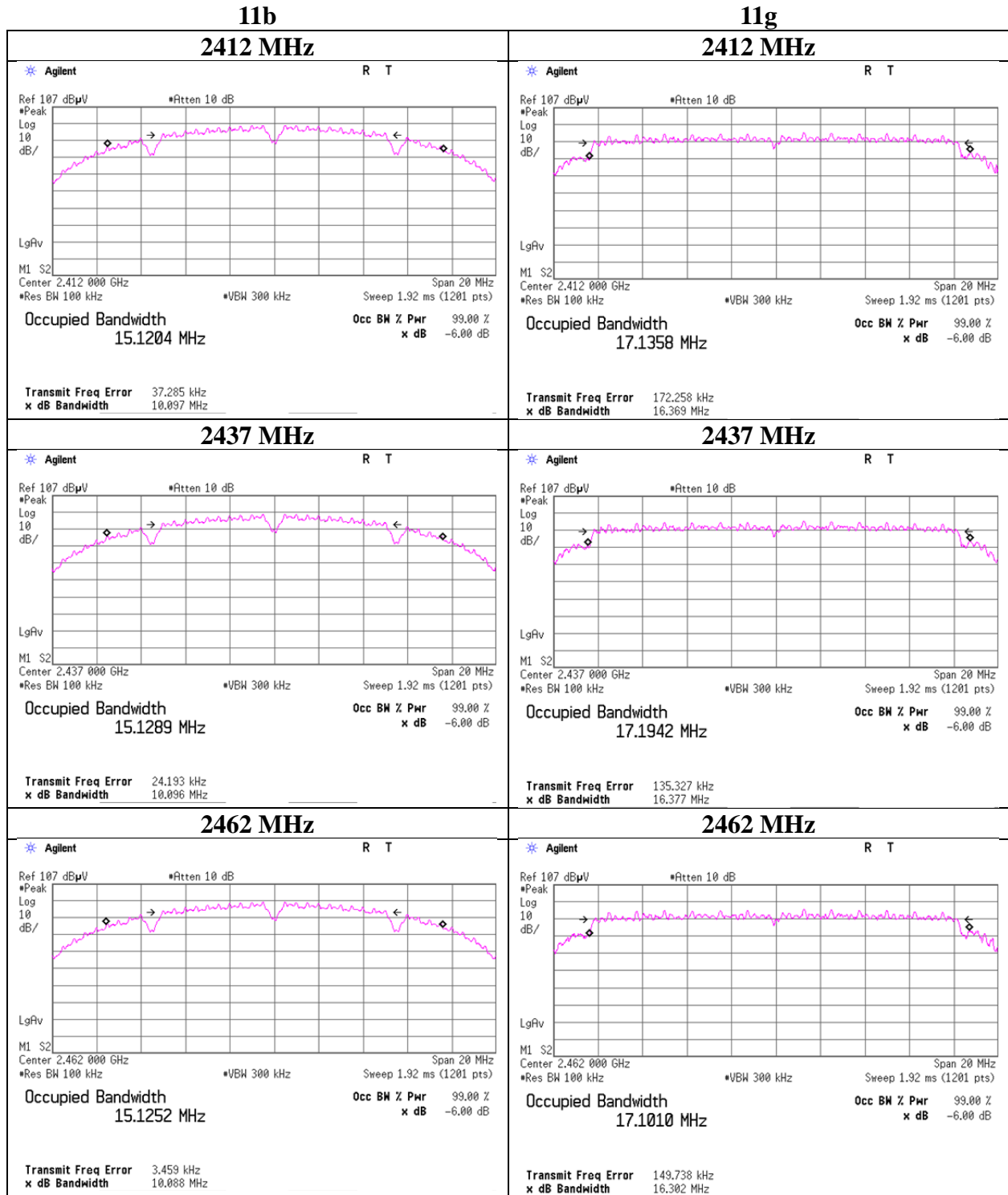

6dB Bandwidth

11n-20

2412 MHz

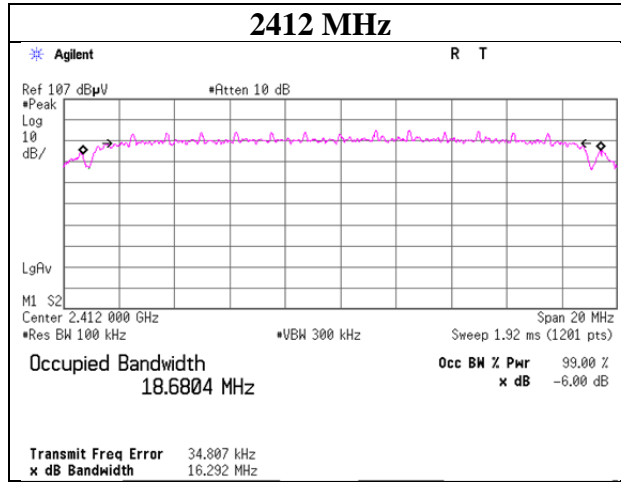

2437 MHz

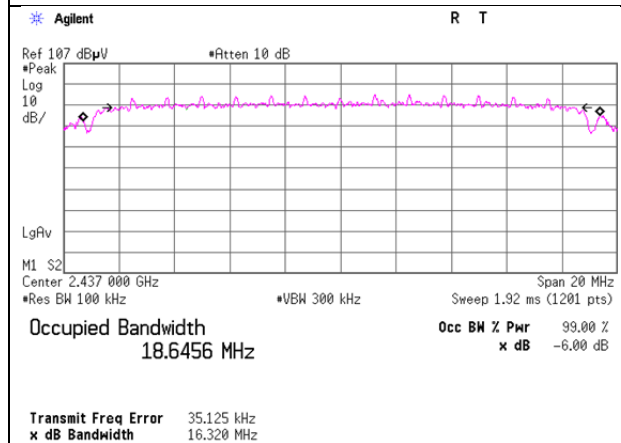

2462 MHz

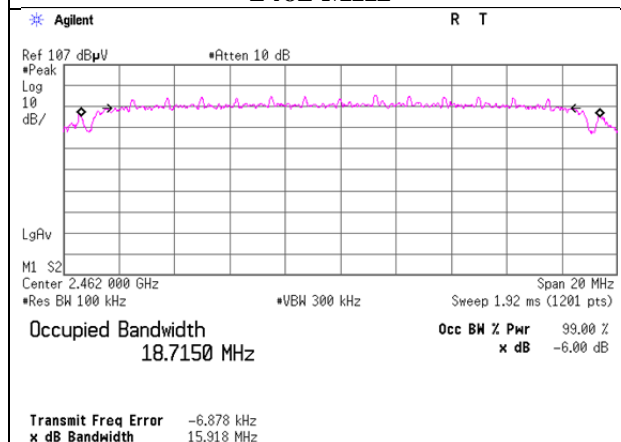

UL Japan, Inc.

Ise EMC Lab.

4383-326 Asama-cho, Ise-shi, Mie-ken 516-0021 JAPAN

Telephone : +81 596 24 8999

Facsimile : +81 596 24 8124

Maximum Peak Output Power

Test place	Ise EMC Lab. No.6 Measurement Room
Report No.	11394939H
Date	August 4, 2016
Temperature / Humidity	23 deg. C / 51 % RH
Engineer	Hiroyuki Furutaka
Mode	Tx 11b

Freq. [MHz]	Reading [dBm]	Cable Loss [dB]	Atten. Loss [dB]	Result		Limit		Margin [dB]
				[dBm]	[mW]	[dBm]	[mW]	
2412	0.53	2.36	10.08	12.97	19.82	30.00	1000	17.03
2437	0.59	2.37	10.08	13.04	20.14	30.00	1000	16.96
2462	1.13	2.37	10.08	13.58	22.80	30.00	1000	16.42

Sample Calculation:

Result = Reading + Cable Loss (including the cable(s) customer supplied) + Attenuator Loss

2437MHz

Rate	Reading	Remark
[Mbps]	[dBm]	
1	0.59	*
2	0.58	
5.5	0.57	
11	0.58	

*: Worst Rate

All comparison were carried out on same frequency and measurement factors.

Maximum Peak Output Power

Test place	Ise EMC Lab. No.6 Measurement Room
Report No.	11394939H
Date	August 4, 2016
Temperature / Humidity	23 deg. C / 51 % RH
Engineer	Hiroyuki Furutaka
Mode	Tx 11g

Freq. [MHz]	Reading [dBm]	Cable Loss [dB]	Atten. Loss [dB]	Result		Limit		Margin [dB]
				[dBm]	[mW]	[dBm]	[mW]	
2412	4.99	2.36	10.08	17.43	55.34	30.00	1000	12.57
2437	4.88	2.37	10.08	17.33	54.08	30.00	1000	12.67
2462	4.91	2.37	10.08	17.36	54.45	30.00	1000	12.64

Sample Calculation:

Result = Reading + Cable Loss (including the cable(s) customer supplied) + Attenuator Loss

2437 MHz

Rate [Mbps]	Reading [dBm]	Remark
6	4.48	
9	4.38	
12	4.82	
18	4.74	
24	4.34	
36	4.70	
48	4.88	*
54	4.47	

*: Worst Rate

All comparison were carried out on same frequency and measurement factors.

Maximum Peak Output Power

Test place : Ise EMC Lab. No.6 Measurement Room
Report No. : 11394939H
Date : August 4, 2016
Temperature / Humidity : 23 deg. C / 51 % RH
Engineer : Hiroyuki Furutaka
Mode : Tx 11n-20

Freq. [MHz]	Reading [dBm]	Cable Loss [dB]	Atten. Loss [dB]	Result		Limit		Margin [dB]
				[dBm]	[mW]	[dBm]	[mW]	
2412	4.82	2.36	10.08	17.26	53.21	30.00	1000	12.74
2437	5.15	2.37	10.08	17.60	57.54	30.00	1000	12.40
2462	5.25	2.37	10.08	17.70	58.88	30.00	1000	12.30

Sample Calculation:

Result = Reading + Cable Loss (including the cable(s) customer supplied) + Attenuator Loss

2437 MHz, Long GI

MCS Number	Reading [dBm]	Remark
0	5.15	*
1	4.79	
2	3.75	
3	3.98	
4	4.90	
5	4.65	
6	4.33	
7	4.55	

* Worst MCS

Average Output Power
(Reference data for RF Exposure)

Test place : Ise EMC Lab. No.6 Measurement Room
Report No. : 11394939H
Date : August 4, 2016
Temperature / Humidity : 23 deg. C / 51 % RH
Engineer : Hiroyuki Furutaka
Mode : Tx

11b 1 Mbps

Freq. [MHz]	Reading [dBm]	Cable Loss [dB]	Atten. Loss [dB]	Result (Time average)		Duty factor [dB]	Result (Burst power average)	
				[dBm]	[mW]		[dBm]	[mW]
2412	-1.60	2.36	10.08	10.84	12.13	0.00	10.84	12.13
2437	-1.48	2.37	10.08	10.97	12.50	0.00	10.97	12.50
2462	-1.06	2.37	10.08	11.39	13.77	0.00	11.39	13.77

11g 6 Mbps

Freq. [MHz]	Reading [dBm]	Cable Loss [dB]	Atten. Loss [dB]	Result (Time average)		Duty factor [dB]	Result (Burst power average)	
				[dBm]	[mW]		[dBm]	[mW]
2412	-4.77	2.36	10.08	7.67	5.85	0.03	7.70	5.89
2437	-4.71	2.37	10.08	7.74	5.94	0.03	7.77	5.98
2462	-4.41	2.37	10.08	8.04	6.37	0.03	8.07	6.41

11n-20 MCS 0

Freq. [MHz]	Reading [dBm]	Cable Loss [dB]	Atten. Loss [dB]	Result (Time average)		Duty factor [dB]	Result (Burst power average)	
				[dBm]	[mW]		[dBm]	[mW]
2412	-4.38	2.36	10.08	8.06	6.40	0.04	8.10	6.46
2437	-4.45	2.37	10.08	8.00	6.31	0.04	8.04	6.37
2462	-4.24	2.37	10.08	8.21	6.62	0.04	8.25	6.68

Sample Calculation:

Result (Time average) = Reading + Cable Loss (including the cable(s) customer supplied) + Attenuator

Result (Burst power average) = Time average + Duty factor

Burst rate confirmation

Test place : Ise EMC Lab. No.6 Measurement Room
Report No. : 11394939H
Date : August 4, 2016
Temperature / Humidity : 23 deg. C / 51 % RH
Engineer : Hiroyuki Furutaka
Mode : Tx

11b 1 Mbps

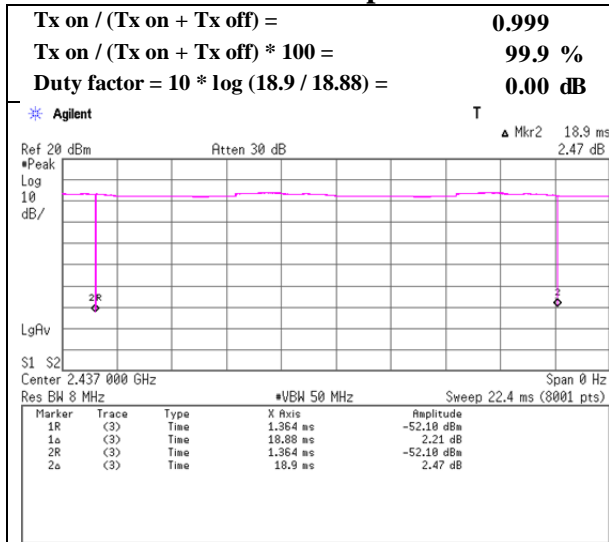

11g 48 Mbps

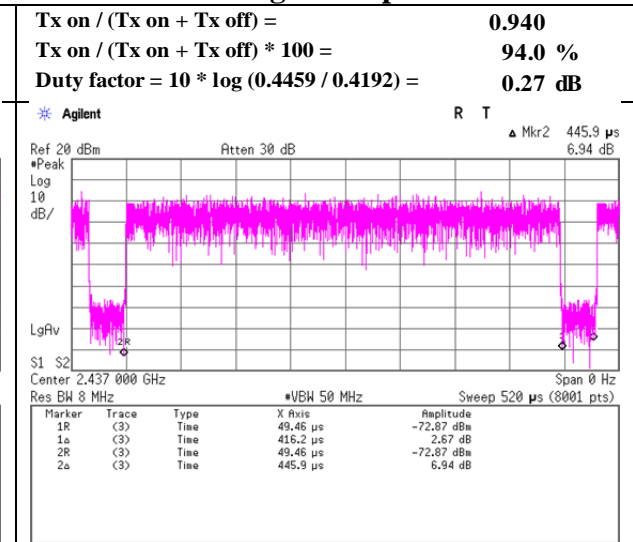

11n-20 MCS 0

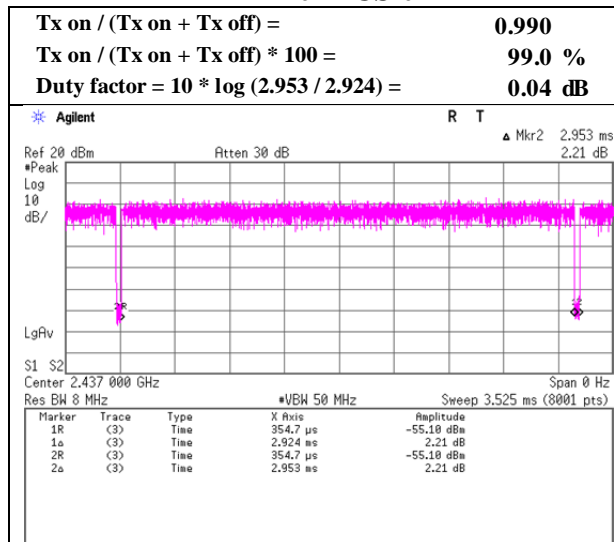

Burst rate confirmation

Test place	Ise EMC Lab. No.6 Measurement Room
Report No.	11394939H
Date	August 4, 2016
Temperature / Humidity	23 deg. C / 51 % RH
Engineer	Hiroyuki Furutaka
Mode	Tx

11g 6 Mbps

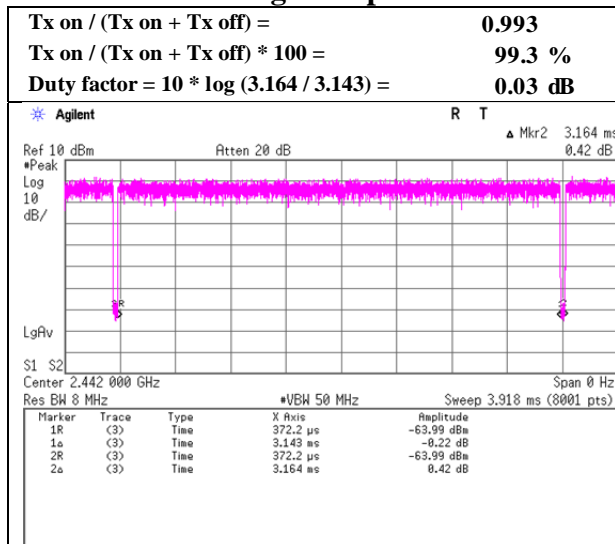

Radiated Spurious Emission

Test place : Ise EMC Lab. No.4 Semi Anechoic Chamber
Report No. : 11394939H
Date : August 4, 2016 August 22, 2016
Temperature / Humidity : 25 deg. C / 47 % RH 23 deg. C / 56 % RH
Engineer : Yuta Moriya Hiroyuki Furutaka
(1 GHz - 10 GHz) (10 GHz - 26.5 GHz)
Mode : Tx 11b 2412 MHz

Polarity	Frequency [MHz]	Detector	Reading [dBuV]	Ant.Fac. [dB/m]	Loss [dB]	Gain [dB]	Result [dBuV/m]	Limit [dBuV/m]	Margin [dB]	Remark
Hori	1039.562	PK	57.1	24.5	5.3	35.0	51.9	73.9	22.0	
Hori	1113.645	PK	51.8	24.7	5.4	34.7	47.2	73.9	26.7	
Hori	1484.949	PK	53.4	25.3	5.8	33.5	51.0	73.9	22.9	
Hori	2227.384	PK	51.5	27.8	6.2	32.2	53.3	73.9	20.6	
Hori	2390.000	PK	42.2	27.9	6.3	32.1	44.3	73.9	29.6	
Hori	3523.957	PK	47.9	28.8	7.1	31.7	52.1	73.9	21.8	
Hori	4824.000	PK	43.6	32.9	8.6	31.3	53.8	73.9	20.1	
Hori	7236.000	PK	42.5	36.8	9.7	32.6	56.4	73.9	17.5	Floor noise
Hori	8195.383	PK	44.8	37.4	10.0	32.7	59.5	73.9	14.4	
Hori	9648.000	PK	41.6	38.1	10.6	32.6	57.7	73.9	16.2	Floor noise
Hori	1039.562	AV	53.4	24.5	5.3	35.0	48.2	53.9	5.7	
Hori	1113.645	AV	46.2	24.7	5.4	34.7	41.6	53.9	12.3	
Hori	1484.949	AV	47.4	25.3	5.8	33.5	45.0	53.9	8.9	
Hori	2227.384	AV	45.7	27.8	6.2	32.2	47.5	53.9	6.4	
Hori	2390.000	AV	34.1	27.9	6.3	32.1	36.2	53.9	17.7	
Hori	3523.957	AV	44.2	28.8	7.1	31.7	48.4	53.9	5.5	
Hori	4824.000	AV	31.8	32.9	8.6	31.3	42.0	53.9	11.9	
Hori	7236.000	AV	31.2	36.8	9.7	32.6	45.1	53.9	8.8	Floor noise
Hori	8195.383	AV	34.5	37.4	10.0	32.7	49.2	53.9	4.7	
Hori	9648.000	AV	31.5	38.1	10.6	32.6	47.6	53.9	6.3	Floor noise
Vert	1039.562	PK	57.2	24.5	5.3	35.0	52.0	73.9	21.9	
Vert	1113.645	PK	50.8	24.7	5.4	34.7	46.2	73.9	27.7	
Vert	1484.949	PK	49.6	25.3	5.8	33.5	47.2	73.9	26.7	
Vert	2227.384	PK	45.7	27.8	6.2	32.2	47.5	73.9	26.4	
Vert	2390.000	PK	42.9	27.9	6.3	32.1	45.0	73.9	28.9	
Vert	3523.957	PK	48.9	28.8	7.1	31.7	53.1	73.9	20.8	
Vert	4824.000	PK	43.2	32.9	8.6	31.3	53.4	73.9	20.5	
Vert	7236.000	PK	42.4	36.8	9.7	32.6	56.3	73.9	17.6	Floor noise
Vert	8195.383	PK	45.3	37.4	10.0	32.7	60.0	73.9	13.9	
Vert	9648.000	PK	41.8	38.1	10.6	32.6	57.9	73.9	16.0	Floor noise
Vert	1039.562	AV	51.1	24.5	5.3	35.0	45.9	53.9	8.0	
Vert	1113.645	AV	44.4	24.7	5.4	34.7	39.8	53.9	14.1	
Vert	1484.949	AV	43.2	25.3	5.8	33.5	40.8	53.9	13.1	
Vert	2227.384	AV	38.6	27.8	6.2	32.2	40.4	53.9	13.5	
Vert	2390.000	AV	34.5	27.9	6.3	32.1	36.6	53.9	17.3	
Vert	3523.957	AV	45.8	28.8	7.1	31.7	50.0	53.9	3.9	
Vert	4824.000	AV	37.3	32.9	8.6	31.3	47.5	53.9	6.4	
Vert	7236.000	AV	33.6	36.8	9.7	32.6	47.5	53.9	6.4	Floor noise
Vert	8195.383	AV	35.0	37.4	10.0	32.7	49.7	53.9	4.2	
Vert	9648.000	AV	31.5	38.1	10.6	32.6	47.6	53.9	6.3	Floor noise

Result = Reading + Ant Factor + Loss (Cable+Attenuator+Filter+Distance factor(above 1 GHz)) - Gain(Amplifier)

*Other frequency noises omitted in this report were not seen or had enough margin (more than 20 dB).

Distance factor: 1 GHz - 10 GHz $20\log(4.3\text{ m} / 3.0\text{ m}) = 3.13\text{ dB}$
10 GHz - 26.5 GHz $20\log(1.0\text{ m} / 3.0\text{ m}) = -9.5\text{ dB}$

20dBc Data Sheet

Polarity	Frequency [MHz]	Detector	Reading [dBuV]	Ant Factor [dB/m]	Loss [dB]	Gain [dB]	Result [dBuV/m]	Limit [dBuV/m]	Margin [dB]	Remark
Hori	2412.000	PK	88.3	28.0	6.3	32.1	90.5	-	-	Carrier
Hori	2400.000	PK	42.3	28.0	6.3	32.1	44.5	70.5	26.0	
Vert	2412.000	PK	85.2	28.0	6.3	32.1	87.4	-	-	Carrier
Vert	2400.000	PK	45.5	28.0	6.3	32.1	47.7	67.4	19.7	

Result = Reading + Ant Factor + Loss (Cable+Attenuator+Filter+Distance factor(above 1 GHz)) - Gain(Amplifier)

UL Japan, Inc.

Ise EMC Lab.

4383-326 Asama-cho, Ise-shi, Mie-ken 516-0021 JAPAN

Telephone : +81 596 24 8999

Facsimile : +81 596 24 8124

Radiated Spurious Emission (Reference Plot for band-edge)

Test place	Ise EMC Lab. No.4 Semi Anechoic Chamber
Report No.	11394939H
Date	August 4, 2016
Temperature / Humidity	25 deg. C / 47 % RH
Engineer	Yuta Moriya
Mode	Tx 11b 2412 MHz

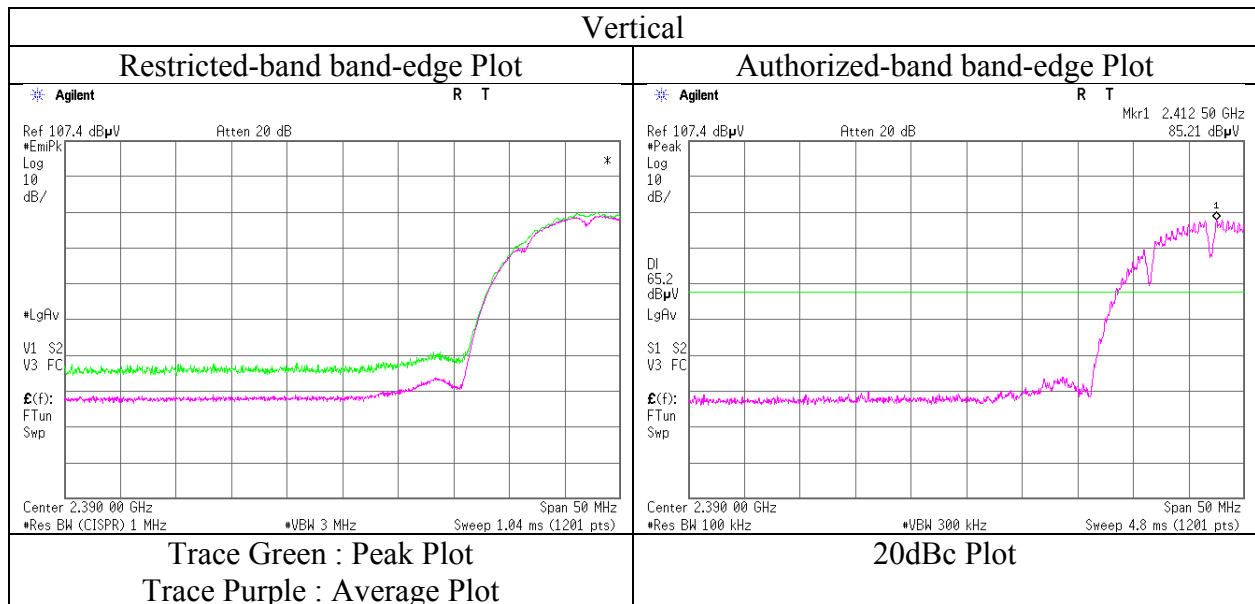
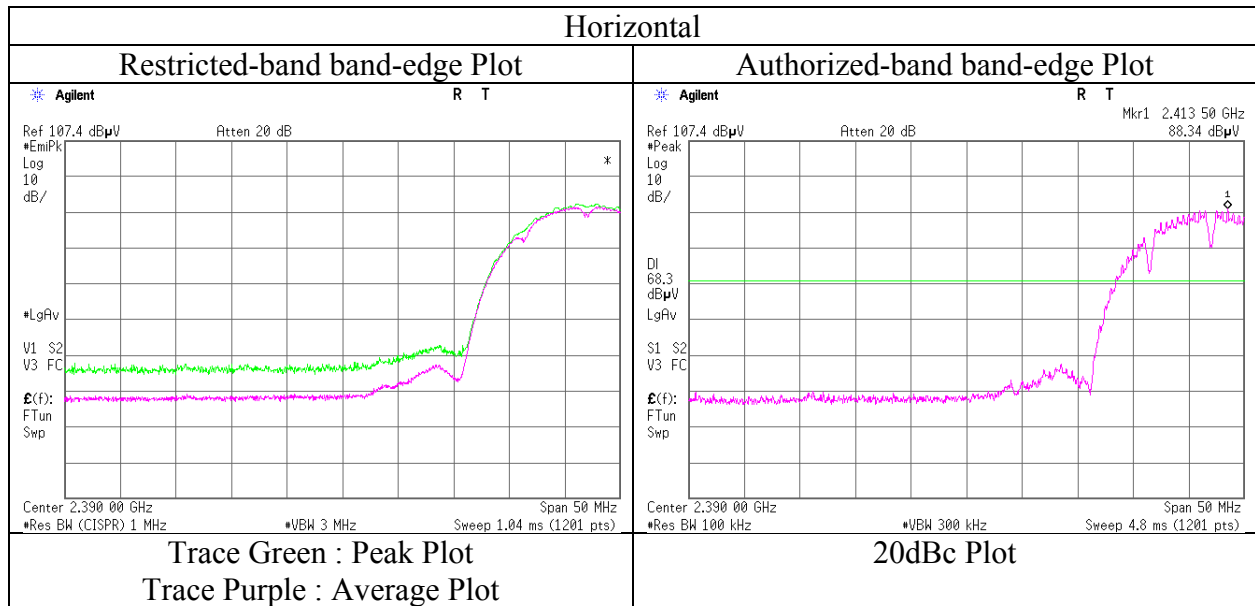

* Final result of restricted band edge was shown in tabular data.

UL Japan, Inc.

Ise EMC Lab.

4383-326 Asama-cho, Ise-shi, Mie-ken 516-0021 JAPAN

Telephone : +81 596 24 8999

Facsimile : +81 596 24 8124

Radiated Spurious Emission

Test place : Ise EMC Lab. No.4 Semi Anechoic Chamber
Report No. : 11394939H
Date : August 4, 2016 August 22, 2016
Temperature / Humidity : 25 deg. C / 47 % RH 23 deg. C / 56 % RH
Engineer : Yuta Moriya Hiroyuki Furutaka
 (1 GHz - 10 GHz) (10 GHz - 26.5 GHz)
Mode : Tx 11b 2437 MHz

Polarity	Frequency [MHz]	Detector	Reading [dBuV]	Ant.Fac. [dB/m]	Loss [dB]	Gain [dB]	Result [dBuV/m]	Limit [dBuV/m]	Margin [dB]	Remark
Hori	1039.455	PK	56.9	24.5	5.3	35.0	51.7	73.9	22.2	
Hori	1113.564	PK	50.9	24.7	5.4	34.7	46.3	73.9	27.6	
Hori	1485.009	PK	52.4	25.3	5.8	33.5	50.0	73.9	23.9	
Hori	2227.507	PK	52.0	27.8	6.2	32.2	53.8	73.9	20.1	
Hori	3523.940	PK	47.7	28.8	7.1	31.7	51.9	73.9	22.0	
Hori	4874.000	PK	40.1	33.1	8.6	31.3	50.5	73.9	23.4	Floor noise
Hori	7311.000	PK	42.1	36.8	9.7	32.6	56.0	73.9	17.9	Floor noise
Hori	8195.263	PK	44.1	37.4	10.0	32.7	58.8	73.9	15.1	
Hori	9748.000	PK	41.9	38.2	10.6	32.7	58.0	73.9	15.9	Floor noise
Hori	1039.455	AV	52.1	24.5	5.3	35.0	46.9	53.9	7.0	
Hori	1113.564	AV	44.9	24.7	5.4	34.7	40.3	53.9	13.6	
Hori	1485.009	AV	46.7	25.3	5.8	33.5	44.3	53.9	9.6	
Hori	2227.507	AV	46.1	27.8	6.2	32.2	47.9	53.9	6.0	
Hori	3523.940	AV	44.5	28.8	7.1	31.7	48.7	53.9	5.2	
Hori	4874.000	AV	31.3	33.1	8.6	31.3	41.7	53.9	12.2	Floor noise
Hori	7311.000	AV	32.4	36.8	9.7	32.6	46.3	53.9	7.6	Floor noise
Hori	8195.263	AV	34.0	37.4	10.0	32.7	48.7	53.9	5.2	
Hori	9748.000	AV	31.5	38.2	10.6	32.7	47.6	53.9	6.3	Floor noise
Vert	1039.455	PK	56.6	24.5	5.3	35.0	51.4	73.9	22.5	
Vert	1113.564	PK	51.1	24.7	5.4	34.7	46.5	73.9	27.4	
Vert	1485.009	PK	48.7	25.3	5.8	33.5	46.3	73.9	27.6	
Vert	2227.507	PK	46.2	27.8	6.2	32.2	48.0	73.9	25.9	
Vert	3523.940	PK	49.6	28.8	7.1	31.7	53.8	73.9	20.1	
Vert	4874.000	PK	40.2	33.1	8.6	31.3	50.6	73.9	23.3	Floor noise
Vert	7311.000	PK	42.2	36.8	9.7	32.6	56.1	73.9	17.8	Floor noise
Vert	8195.263	PK	44.8	37.4	10.0	32.7	59.5	73.9	14.4	
Vert	9748.000	PK	42.0	38.2	10.6	32.7	58.1	73.9	15.8	Floor noise
Vert	1039.455	AV	51.7	24.5	5.3	35.0	46.5	53.9	7.4	
Vert	1113.564	AV	45.7	24.7	5.4	34.7	41.1	53.9	12.8	
Vert	1485.009	AV	42.1	25.3	5.8	33.5	39.7	53.9	14.2	
Vert	2227.507	AV	39.4	27.8	6.2	32.2	41.2	53.9	12.7	
Vert	3523.940	AV	45.9	28.8	7.1	31.7	50.1	53.9	3.8	
Vert	4874.000	AV	31.8	33.1	8.6	31.3	42.2	53.9	11.7	Floor noise
Vert	7311.000	AV	33.2	36.8	9.7	32.6	47.1	53.9	6.8	Floor noise
Vert	8195.263	AV	34.2	37.4	10.0	32.7	48.9	53.9	5.0	
Vert	9748.000	AV	31.5	38.2	10.6	32.7	47.6	53.9	6.3	Floor noise

Result = Reading + Ant Factor + Loss (Cable+Attenuator+Filter+Distance factor(above 1 GHz)) - Gain(Amplifier)

*Other frequency noises omitted in this report were not seen or had enough margin (more than 20 dB).

Distance factor: 1 GHz - 10 GHz 20log(4.3 m / 3.0 m) = 3.13 dB
 10 GHz - 26.5 GHz 20log(1.0 m / 3.0 m) = -9.5 dB

Radiated Spurious Emission

Test place : Ise EMC Lab. No.4 Semi Anechoic Chamber
Report No. : 11394939H
Date : August 4, 2016 August 22, 2016
Temperature / Humidity : 25 deg. C / 47 % RH 23 deg. C / 56 % RH
Engineer : Yuta Moriya Hiroyuki Furutaka
 (1 GHz - 10 GHz) (10 GHz - 26.5 GHz)
Mode : Tx 11b 2462 MHz

Polarity	Frequency [MHz]	Detector	Reading [dBuV]	Ant.Fac. [dB/m]	Loss [dB]	Gain [dB]	Result [dBuV/m]	Limit [dBuV/m]	Margin [dB]	Remark
Hori	1039.397	PK	58.6	24.5	5.3	35.0	53.4	73.9	20.5	
Hori	1113.831	PK	51.5	24.7	5.4	34.7	46.9	73.9	27.0	
Hori	1484.915	PK	53.6	25.3	5.8	33.5	51.2	73.9	22.7	
Hori	2227.439	PK	49.4	27.8	6.2	32.2	51.2	73.9	22.7	
Hori	2483.500	PK	44.3	28.1	6.4	32.1	46.7	73.9	27.2	
Hori	3523.940	PK	47.7	28.8	7.1	31.7	51.9	73.9	22.0	
Hori	4924.000	PK	40.7	33.3	8.7	31.3	51.4	73.9	22.5	Floor noise
Hori	7386.000	PK	42.7	36.8	9.7	32.6	56.6	73.9	17.3	Floor noise
Hori	8195.356	PK	44.7	37.4	10.0	32.7	59.4	73.9	14.5	
Hori	9848.000	PK	42.2	38.2	10.6	32.7	58.3	73.9	15.6	Floor noise
Hori	1039.397	AV	54.1	24.5	5.3	35.0	48.9	53.9	5.0	
Hori	1113.831	AV	46.5	24.7	5.4	34.7	41.9	53.9	12.0	
Hori	1484.915	AV	47.4	25.3	5.8	33.5	45.0	53.9	8.9	
Hori	2227.439	AV	43.1	27.8	6.2	32.2	44.9	53.9	9.0	
Hori	2483.500	AV	35.3	28.1	6.4	32.1	37.7	53.9	16.2	
Hori	3523.940	AV	44.5	28.8	7.1	31.7	48.7	53.9	5.2	
Hori	4924.000	AV	31.2	33.3	8.7	31.3	41.9	53.9	12.0	Floor noise
Hori	7386.000	AV	33.3	36.8	9.7	32.6	47.2	53.9	6.7	Floor noise
Hori	8195.356	AV	34.3	37.4	10.0	32.7	49.0	53.9	4.9	
Hori	9848.000	AV	31.6	38.2	10.6	32.7	47.7	53.9	6.2	Floor noise
Vert	1039.397	PK	57.3	24.5	5.3	35.0	52.1	73.9	21.8	
Vert	1113.831	PK	50.9	24.7	5.4	34.7	46.3	73.9	27.6	
Vert	1484.915	PK	49.4	25.3	5.8	33.5	47.0	73.9	26.9	
Vert	2227.439	PK	48.2	27.8	6.2	32.2	50.0	73.9	23.9	
Vert	2483.500	PK	45.0	28.1	6.4	32.1	47.4	73.9	26.5	
Vert	3523.940	PK	49.6	28.8	7.1	31.7	53.8	73.9	20.1	
Vert	4924.000	PK	40.1	33.3	8.7	31.3	50.8	73.9	23.1	Floor noise
Vert	7386.000	PK	42.6	36.8	9.7	32.6	56.5	73.9	17.4	Floor noise
Vert	8195.356	PK	44.1	37.4	10.0	32.7	58.8	73.9	15.1	
Vert	9848.000	PK	42.0	38.2	9.9	32.7	57.4	73.9	16.5	Floor noise
Vert	1039.397	AV	52.6	24.5	5.3	35.0	47.4	53.9	6.5	
Vert	1113.831	AV	45.2	24.7	5.4	34.7	40.6	53.9	13.3	
Vert	1484.915	AV	44.3	25.3	5.8	33.5	41.9	53.9	12.0	
Vert	2227.439	AV	41.1	27.8	6.2	32.2	42.9	53.9	11.0	
Vert	2483.500	AV	35.5	28.1	6.4	32.1	37.9	53.9	16.0	
Vert	3523.940	AV	45.9	28.8	7.1	31.7	50.1	53.9	3.8	
Vert	4924.000	AV	31.7	33.3	8.7	31.3	42.4	53.9	11.5	Floor noise
Vert	7386.000	AV	33.5	36.8	9.7	32.6	47.4	53.9	6.5	Floor noise
Vert	8195.356	AV	33.6	37.4	10.0	32.7	48.3	53.9	5.6	
Vert	9848.000	AV	31.6	38.2	10.6	32.7	47.7	53.9	6.2	Floor noise

Result = Reading + Ant Factor + Loss (Cable+Attenuator+Filter+Distance factor(above 1 GHz)) - Gain(Amplifier)

*Other frequency noises omitted in this report were not seen or had enough margin (more than 20 dB).

Distance factor: 1 GHz - 10 GHz 20log(4.3 m / 3.0 m) = 3.13 dB
 10 GHz - 26.5 GHz 20log(1.0 m / 3.0 m) = -9.5 dB

Radiated Spurious Emission
(Reference Plot for band-edge)

Test place	Ise EMC Lab. No.4 Semi Anechoic Chamber
Report No.	11394939H
Date	August 4, 2016
Temperature / Humidity	25 deg. C / 47 % RH
Engineer	Yuta Moriya
Mode	Tx 11b 2462 MHz

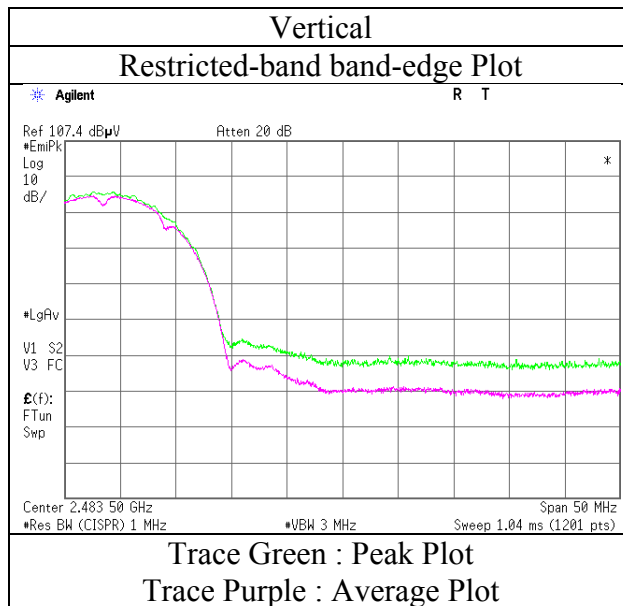
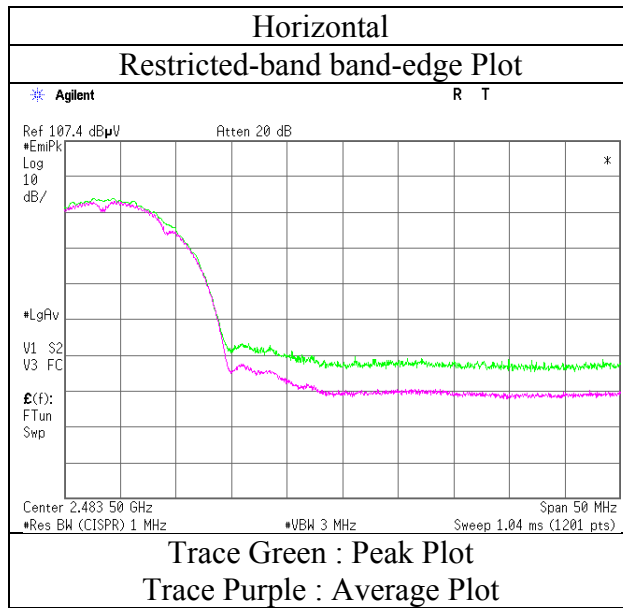

* Final result of restricted band edge was shown in tabular data.

Radiated Spurious Emission

Test place : Ise EMC Lab. No.4 Semi Anechoic Chamber
Report No. : 11394939H
Date : August 4, 2016 August 22, 2016
Temperature / Humidity : 25 deg. C / 47 % RH 23 deg. C / 56 % RH
Engineer : Yuta Moriya Hiroyuki Furutaka
(1 GHz - 10 GHz) (10 GHz - 26.5 GHz)
Mode : Tx 11n-20 2412 MHz

Polarity	Frequency [MHz]	Detector	Reading [dBuV]	Ant.Fac. [dB/m]	Loss [dB]	Gain [dB]	Result [dBuV/m]	Limit [dBuV/m]	Margin [dB]	Remark
Hori	1039.406	PK	59.1	24.5	5.3	35.0	53.9	73.9	20.0	
Hori	1113.690	PK	51.0	24.7	5.4	34.7	46.4	73.9	27.5	
Hori	1484.947	PK	54.1	25.3	5.8	33.5	51.7	73.9	22.2	
Hori	2227.244	PK	51.3	27.8	6.2	32.2	53.1	73.9	20.8	
Hori	2390.000	PK	48.5	27.9	6.3	32.1	50.6	73.9	23.3	
Hori	3523.977	PK	48.6	28.8	7.1	31.7	52.8	73.9	21.1	
Hori	4824.000	PK	40.5	32.9	8.6	31.3	50.7	73.9	23.2	Floor noise
Hori	7236.000	PK	42.1	36.8	9.7	32.6	56.0	73.9	17.9	Floor noise
Hori	8195.164	PK	45.1	37.4	9.2	32.7	59.0	73.9	14.9	
Hori	9648.000	PK	41.4	38.1	10.6	32.6	57.5	73.9	16.4	Floor noise
Hori	1039.406	AV	54.3	24.5	5.3	35.0	49.1	53.9	4.8	
Hori	1113.690	AV	45.6	24.7	5.4	34.7	41.0	53.9	12.9	
Hori	1484.947	AV	48.5	25.3	5.8	33.5	46.1	53.9	7.8	
Hori	2227.244	AV	46.6	27.8	6.2	32.2	48.4	53.9	5.5	
Hori	2390.000	AV	35.3	27.9	6.3	32.1	37.4	53.9	16.5	
Hori	3523.977	AV	45.4	28.8	7.1	31.7	49.6	53.9	4.3	
Hori	4824.000	AV	29.9	32.9	8.6	31.3	40.1	53.9	13.8	Floor noise
Hori	7236.000	AV	30.8	36.8	9.7	32.6	44.7	53.9	9.2	Floor noise
Hori	8195.164	AV	34.9	37.4	9.2	32.7	48.8	53.9	5.1	
Hori	9648.000	AV	31.4	38.1	10.6	32.6	47.5	53.9	6.4	Floor noise
Vert	1039.406	PK	57.5	24.5	5.3	35.0	52.3	73.9	21.6	
Vert	1113.690	PK	51.1	24.7	5.4	34.7	46.5	73.9	27.4	
Vert	1484.947	PK	50.2	25.3	5.8	33.5	47.8	73.9	26.1	
Vert	2227.244	PK	45.7	27.8	6.2	32.2	47.5	73.9	26.4	
Vert	2390.000	PK	47.6	27.9	6.3	32.1	49.7	73.9	24.2	
Vert	3523.977	PK	48.1	28.8	7.1	31.7	52.3	73.9	21.6	
Vert	4824.000	PK	40.5	32.9	8.6	31.3	50.7	73.9	23.2	Floor noise
Vert	7236.000	PK	42.1	36.8	9.7	32.6	56.0	73.9	17.9	Floor noise
Vert	8195.164	PK	44.3	37.4	10.0	32.7	59.0	73.9	14.9	
Vert	9648.000	PK	41.5	38.1	10.6	32.6	57.6	73.9	16.3	Floor noise
Vert	1039.406	AV	51.9	24.5	5.3	35.0	46.7	53.9	7.2	
Vert	1113.690	AV	44.9	24.7	5.4	34.7	40.3	53.9	13.6	
Vert	1484.947	AV	43.4	25.3	5.8	33.5	41.0	53.9	12.9	
Vert	2227.244	AV	38.6	27.8	6.2	32.2	40.4	53.9	13.5	
Vert	2390.000	AV	34.5	27.9	6.3	32.1	36.6	53.9	17.3	
Vert	3523.977	AV	43.9	28.8	7.1	31.7	48.1	53.9	5.8	
Vert	4824.000	AV	29.9	32.9	8.6	31.3	40.1	53.9	13.8	Floor noise
Vert	7236.000	AV	31.1	36.8	9.7	32.6	45.0	53.9	8.9	Floor noise
Vert	8195.164	AV	33.2	37.4	10.0	32.7	47.9	53.9	6.0	
Vert	9648.000	AV	31.4	38.1	10.6	32.6	47.5	53.9	6.4	Floor noise

Result = Reading + Ant Factor + Loss (Cable+Attenuator+Filter+Distance factor(above 1 GHz)) - Gain(Amplifier)

*Other frequency noises omitted in this report were not seen or had enough margin (more than 20 dB).

Distance factor: 1 GHz - 10 GHz 20log(4.3 m / 3.0 m) = 3.13 dB
10 GHz - 26.5 GHz 20log(1.0 m / 3.0 m) = -9.5 dB

20dBc Data Sheet

Polarity	Frequency [MHz]	Detector	Reading [dBuV]	Ant Factor [dB/m]	Loss [dB]	Gain [dB]	Result [dBuV/m]	Limit [dBuV/m]	Margin [dB]	Remark
Hori	2412.000	PK	83.2	28.0	6.3	32.1	85.4	-	-	Carrier
Hori	2400.000	PK	53.6	28.0	6.3	32.1	55.8	65.4	9.6	
Vert	2412.000	PK	84.4	28.0	6.3	32.1	86.6	-	-	Carrier
Vert	2400.000	PK	53.5	28.0	6.3	32.1	55.7	66.6	10.9	

Result = Reading + Ant Factor + Loss (Cable+Attenuator+Filter+Distance factor(above 1 GHz)) - Gain(Amplifier)

UL Japan, Inc.

Ise EMC Lab.

4383-326 Asama-cho, Ise-shi, Mie-ken 516-0021 JAPAN

Telephone : +81 596 24 8999

Facsimile : +81 596 24 8124

Radiated Spurious Emission
(Reference Plot for band-edge)

Test place : Ise EMC Lab. No.4 Semi Anechoic Chamber
Report No. : 11394939H
Date : August 4, 2016
Temperature / Humidity : 25 deg. C / 47 % RH
Engineer : Yuta Moriya
Mode : Tx 11n-20 2412 MHz

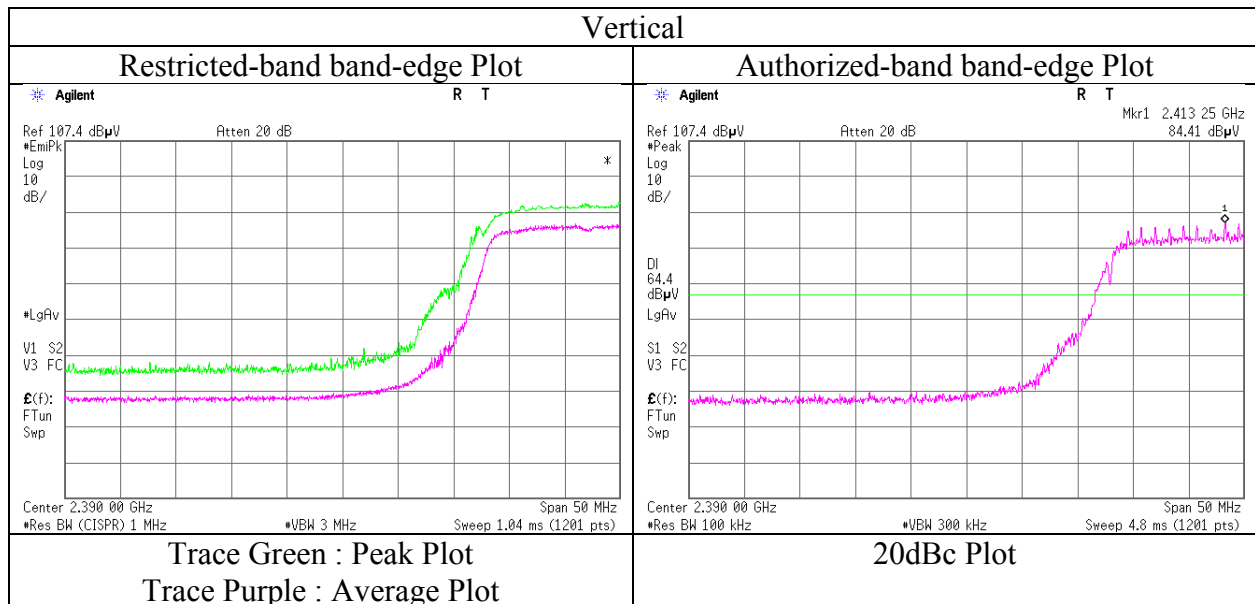
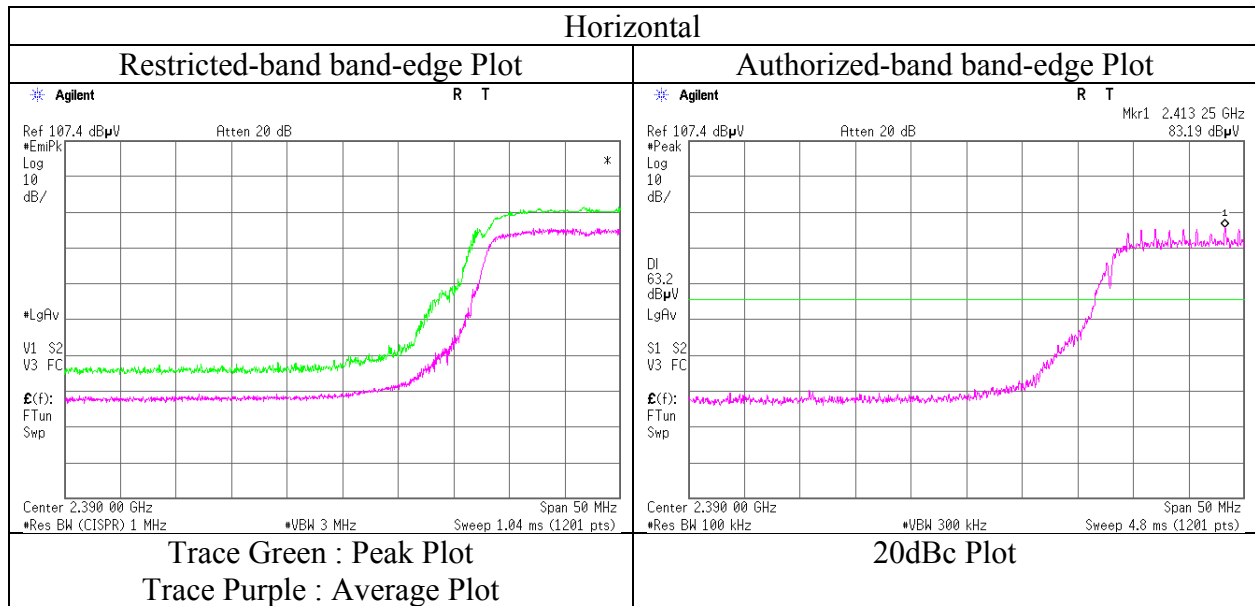

* Final result of restricted band edge was shown in tabular data.

Radiated Spurious Emission

Test place : Ise EMC Lab. No.4 Semi Anechoic Chamber
Report No. : 11394939H
Date : August 4, 2016 August 22, 2016
Temperature / Humidity : 25 deg. C / 47 % RH 23 deg. C / 56 % RH
Engineer : Yuta Moriya Hiroyuki Furutaka
(1 GHz - 10 GHz) (10 GHz - 26.5 GHz)
Mode : Tx 11n-20 2437 MHz

Polarity	Frequency [MHz]	Detector	Reading [dBuV]	Ant.Fac. [dB/m]	Loss [dB]	Gain [dB]	Result [dBuV/m]	Limit [dBuV/m]	Margin [dB]	Remark
Hori	1039.560	PK	58.6	24.5	5.3	35.0	53.4	73.9	20.5	
Hori	1113.713	PK	51.7	24.7	5.4	34.7	47.1	73.9	26.8	
Hori	1484.889	PK	53.6	25.3	5.8	33.5	51.2	73.9	22.7	
Hori	2227.507	PK	51.5	27.8	6.2	32.2	53.3	73.9	20.6	
Hori	3523.997	PK	48.4	28.8	7.1	31.7	52.6	73.9	21.3	
Hori	4874.000	PK	40.7	33.1	8.6	31.3	51.1	73.9	22.8	Floor noise
Hori	7311.000	PK	42.0	36.8	9.7	32.6	55.9	73.9	18.0	Floor noise
Hori	8195.745	PK	44.7	37.4	10.0	32.7	59.4	73.9	14.5	
Hori	9748.000	PK	41.1	38.2	10.6	32.7	57.2	73.9	16.7	Floor noise
Hori	1039.560	AV	54.5	24.5	5.3	35.0	49.3	53.9	4.6	
Hori	1113.713	AV	46.4	24.7	5.4	34.7	41.8	53.9	12.1	
Hori	1484.889	AV	48.1	25.3	5.8	33.5	45.7	53.9	8.2	
Hori	2227.507	AV	45.5	27.8	6.2	32.2	47.3	53.9	6.6	
Hori	3523.997	AV	44.5	28.8	7.1	31.7	48.7	53.9	5.2	
Hori	4874.000	AV	32.1	33.1	8.6	31.3	42.5	53.9	11.4	Floor noise
Hori	7311.000	AV	32.1	36.8	9.7	32.6	46.0	53.9	7.9	Floor noise
Hori	8195.745	AV	34.5	37.4	10.0	32.7	49.2	53.9	4.7	
Hori	9748.000	AV	31.3	38.2	10.6	32.7	47.4	53.9	6.5	Floor noise
Vert	1039.560	PK	56.9	24.5	5.3	35.0	51.7	73.9	22.2	
Vert	1113.713	PK	52.2	24.7	5.4	34.7	47.6	73.9	26.3	
Vert	1484.889	PK	50.9	25.3	5.8	33.5	48.5	73.9	25.4	
Vert	2227.507	PK	50.3	27.8	6.2	32.2	52.1	73.9	21.8	
Vert	3523.997	PK	47.8	28.8	7.1	31.7	52.0	73.9	21.9	
Vert	4874.000	PK	40.4	33.1	8.6	31.3	50.8	73.9	23.1	Floor noise
Vert	7311.000	PK	42.2	36.8	9.7	32.6	56.1	73.9	17.8	Floor noise
Vert	8195.745	PK	43.2	37.4	10.0	32.7	57.9	73.9	16.0	
Vert	9748.000	PK	41.4	38.2	10.6	32.7	57.5	73.9	16.4	Floor noise
Vert	1039.560	AV	51.9	24.5	5.3	35.0	46.7	53.9	7.2	
Vert	1113.713	AV	47.5	24.7	5.4	34.7	42.9	53.9	11.0	
Vert	1484.889	AV	46.3	25.3	5.8	33.5	43.9	53.9	10.0	
Vert	2227.507	AV	46.0	27.8	6.2	32.2	47.8	53.9	6.1	
Vert	3523.997	AV	43.6	28.8	7.1	31.7	47.8	53.9	6.1	
Vert	4874.000	AV	31.9	33.1	8.6	31.3	42.3	53.9	11.6	Floor noise
Vert	7311.000	AV	33.1	36.8	9.7	32.6	47.0	53.9	6.9	Floor noise
Vert	8195.745	AV	32.4	37.4	10.0	32.7	47.1	53.9	6.8	
Vert	9748.000	AV	31.4	38.2	10.6	32.7	47.5	53.9	6.4	Floor noise

Result = Reading + Ant Factor + Loss (Cable+Attenuator+Filter+Distance factor(above 1 GHz)) - Gain(Amplifier)

*Other frequency noises omitted in this report were not seen or had enough margin (more than 20 dB).

Distance factor: 1 GHz - 10 GHz 20log(4.3 m / 3.0 m) = 3.13 dB
 10 GHz - 26.5 GHz 20log(1.0 m / 3.0 m) = -9.5 dB

Radiated Spurious Emission

Test place Ise EMC Lab. No.4 Semi Anechoic Chamber
Report No. 11394939H
Date August 4, 2016 August 22, 2016 August 24, 2016
Temperature / Humidity 25 deg. C / 47 % RH 23 deg. C / 56 % RH 25 deg. C / 47 % RH
Engineer Yuta Moriya Hiroyuki Furutaka Shinichi Miyazono
(1 GHz - 10 GHz) (10 GHz - 26.5 GHz) (Below 1 GHz)
Mode Tx 11n-20 2462 MHz

Polarity	Frequency [MHz]	Detector	Reading [dBuV]	Ant.Fac. [dB/m]	Loss [dB]	Gain [dB]	Result [dBuV/m]	Limit [dBuV/m]	Margin [dB]	Remark
Hori	74.258	QP	42.2	6.0	7.7	32.2	23.7	40.0	16.3	
Hori	148.434	QP	45.2	14.7	8.6	32.1	36.4	43.5	7.1	
Hori	445.492	QP	39.5	16.6	10.9	31.9	35.1	46.0	10.9	
Hori	668.216	QP	37.0	19.6	12.3	32.1	36.8	46.0	9.2	
Hori	742.460	QP	36.8	20.2	12.6	31.8	37.8	46.0	8.2	
Hori	884.737	QP	40.2	21.9	13.3	31.0	44.4	46.0	1.6	
Hori	1039.458	PK	56.2	24.5	5.3	35.0	51.0	73.9	22.9	
Hori	1113.674	PK	50.9	24.7	5.4	34.7	46.3	73.9	27.6	
Hori	1485.033	PK	54.1	25.3	5.8	33.5	51.7	73.9	22.2	
Hori	2227.458	PK	48.9	27.8	6.2	32.2	50.7	73.9	23.2	
Hori	2483.500	PK	55.6	28.1	6.4	32.1	58.0	73.9	15.9	
Hori	3523.940	PK	48.3	28.8	7.1	31.7	52.5	73.9	21.4	
Hori	4924.000	PK	40.4	33.3	8.7	31.3	51.1	73.9	22.8	Floor noise
Hori	7386.000	PK	42.2	36.8	9.7	32.6	56.1	73.9	17.8	Floor noise
Hori	8195.023	PK	44.6	37.4	10.0	32.7	59.3	73.9	14.6	
Hori	9848.000	PK	42.2	38.2	10.6	32.7	58.3	73.9	15.6	Floor noise
Hori	1039.458	AV	51.3	24.5	5.3	35.0	46.1	53.9	7.8	
Hori	1113.674	AV	45.7	24.7	5.4	34.7	41.1	53.9	12.8	
Hori	1485.033	AV	48.7	25.3	5.8	33.5	46.3	53.9	7.6	
Hori	2227.458	AV	41.3	27.8	6.2	32.2	43.1	53.9	10.8	
Hori	2483.500	AV	38.6	28.1	6.4	32.1	41.0	53.9	12.9	
Hori	3523.940	AV	45.3	28.8	7.1	31.7	49.5	53.9	4.4	
Hori	4924.000	AV	31.4	33.3	8.7	31.3	42.1	53.9	11.8	Floor noise
Hori	7386.000	AV	33.4	36.8	9.7	32.6	47.3	53.9	6.6	Floor noise
Hori	8195.023	AV	33.9	37.4	10.0	32.7	48.6	53.9	5.3	
Hori	9848.000	AV	31.5	38.2	10.6	32.7	47.6	53.9	6.3	Floor noise
Vert	74.258	QP	50.3	6.0	7.7	32.2	31.8	40.0	8.2	
Vert	148.434	QP	43.2	14.7	8.6	32.1	34.4	43.5	9.1	
Vert	445.492	QP	42.9	16.6	10.9	31.9	38.5	46.0	7.5	
Vert	668.216	QP	38.3	19.6	12.3	32.1	38.1	46.0	7.9	
Vert	742.460	QP	33.2	20.2	12.6	31.8	34.2	46.0	11.8	
Vert	884.737	QP	35.9	21.9	13.3	31.0	40.1	46.0	5.9	
Vert	1039.458	PK	54.7	24.5	5.3	35.0	49.5	73.9	24.4	
Vert	1113.674	PK	51.6	24.7	5.4	34.7	47.0	73.9	26.9	
Vert	1485.033	PK	50.0	25.3	5.8	33.5	47.6	73.9	26.3	
Vert	2227.458	PK	46.4	27.8	6.2	32.2	48.2	73.9	25.7	
Vert	2483.500	PK	58.7	28.1	6.4	32.1	61.1	73.9	12.8	
Vert	3523.940	PK	49.5	28.8	7.1	31.7	53.7	73.9	20.2	
Vert	4924.000	PK	40.3	33.3	8.7	31.3	51.0	73.9	22.9	Floor noise
Vert	7386.000	PK	42.3	36.8	9.7	32.6	56.2	73.9	17.7	Floor noise
Vert	8195.023	PK	45.1	37.4	10.0	32.7	59.8	73.9	14.1	
Vert	9848.000	PK	41.9	38.2	10.6	32.7	58.0	73.9	15.9	Floor noise
Vert	1039.458	AV	49.2	24.5	5.3	35.0	44.0	53.9	9.9	
Vert	1113.674	AV	44.5	24.7	5.4	34.7	39.9	53.9	14.0	
Vert	1485.033	AV	42.0	25.3	5.8	33.5	39.6	53.9	14.3	
Vert	2227.458	AV	36.5	27.8	6.2	32.2	38.3	53.9	15.6	
Vert	2483.500	AV	44.7	28.1	6.4	32.1	47.1	53.9	6.8	
Vert	3523.940	AV	45.9	28.8	7.1	31.7	50.1	53.9	3.8	
Vert	4924.000	AV	31.6	33.3	8.7	31.3	42.3	53.9	11.6	Floor noise

Result = Reading + Ant Factor + Loss (Cable+Attenuator+Filter+Distance factor(above 1 GHz)) - Gain(Amplifier)

*Other frequency noises omitted in this report were not seen or had enough margin (more than 20 dB).

Distance factor: 1 GHz - 10 GHz 20log(4.3 m / 3.0 m) = 3.13 dB
10 GHz - 26.5 GHz 20log(1.0 m / 3.0 m) = -9.5 dB

UL Japan, Inc.

Ise EMC Lab.

4383-326 Asama-cho, Ise-shi, Mie-ken 516-0021 JAPAN

Telephone : +81 596 24 8999

Facsimile : +81 596 24 8124

Radiated Spurious Emission
(Reference Plot for band-edge)

Test place : Ise EMC Lab. No.4 Semi Anechoic Chamber
Report No. : 11394939H
Date : August 4, 2016
Temperature / Humidity : 25 deg. C / 47 % RH
Engineer : Yuta Moriya
Mode : Tx 11n-20 2462 MHz

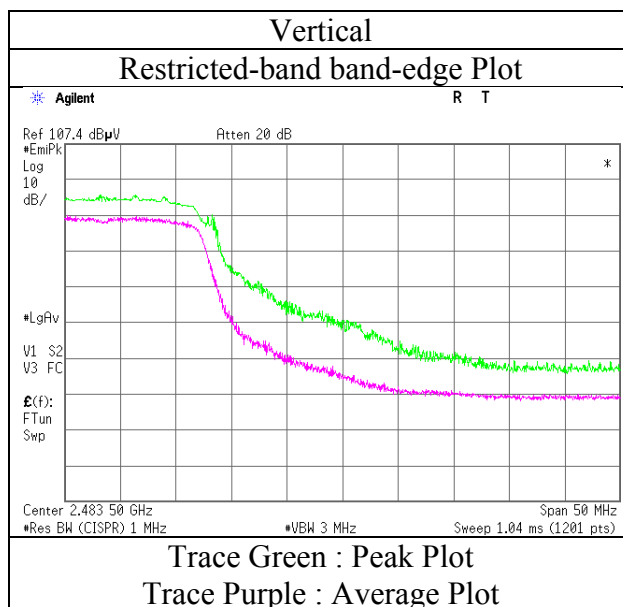
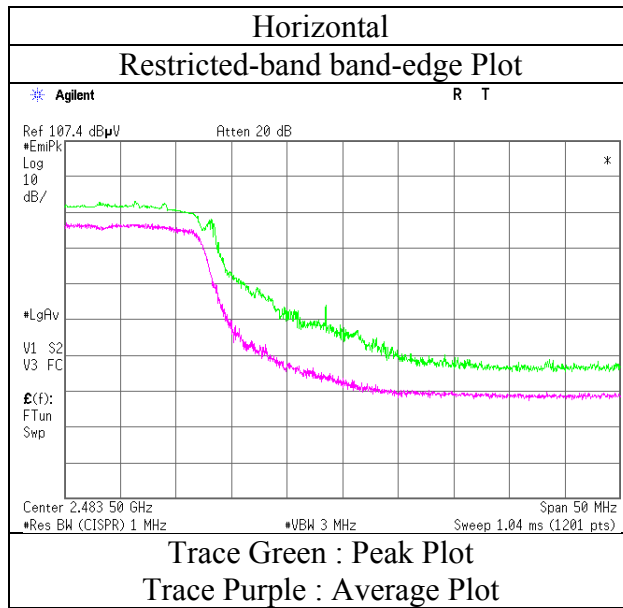

* Final result of restricted band edge was shown in tabular data.

Radiated Spurious Emission
(Plot data, Worst case)

Test place	Ise EMC Lab. No.4 Semi Anechoic Chamber		
Report No.	11394939H		
Date	August 4, 2016	August 22, 2016	August 24, 2016
Temperature / Humidity	25 deg. C / 47 % RH	23 deg. C / 56 % RH	25 deg. C / 47 % RH
Engineer	Yuta Moriya (1 GHz - 10 GHz)	Hiroyuki Furutaka (10 GHz - 26.5 GHz)	Shinichi Miyazono (Below 1 GHz)
Mode	Tx 11n-20 2462 MHz		

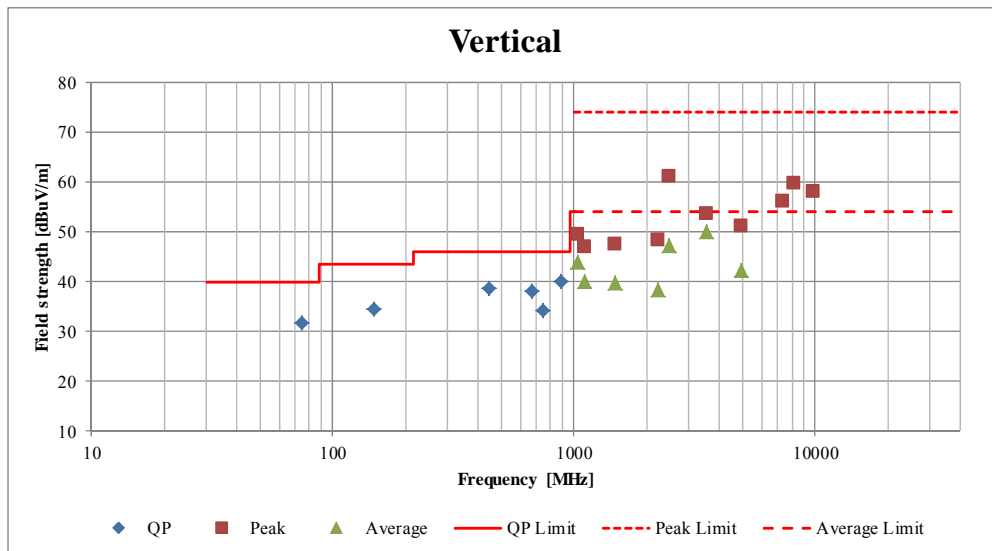
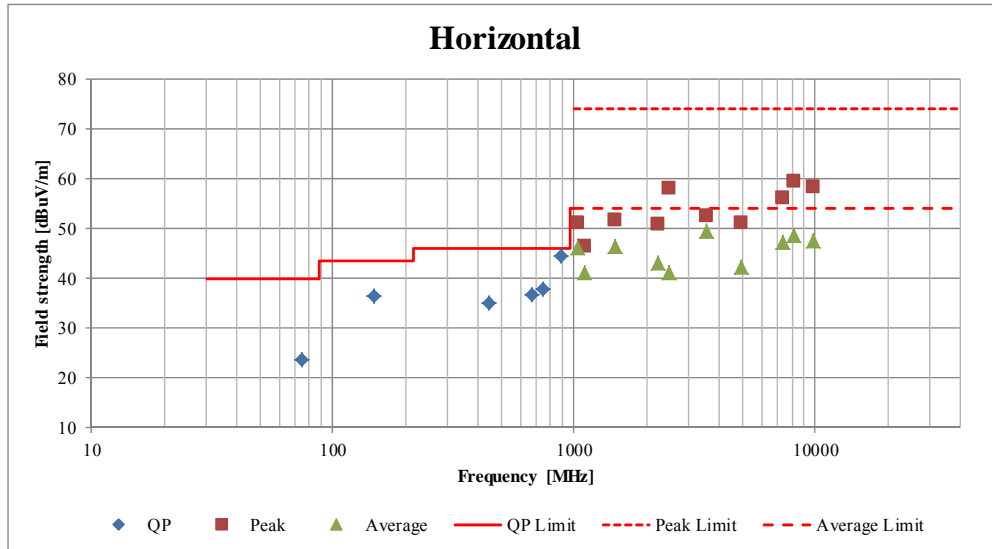

*These plots data contains sufficient number to show the trend of characteristic features for EUT.

Conducted Spurious Emission

Test place	Ise EMC Lab. No.6 Measurement Room
Report No.	11394939H
Date	August 4, 2016
Temperature / Humidity	23 deg. C / 51 % RH
Engineer	Hiroyuki Furutaka
Mode	Tx 11n-20 2462 MHz

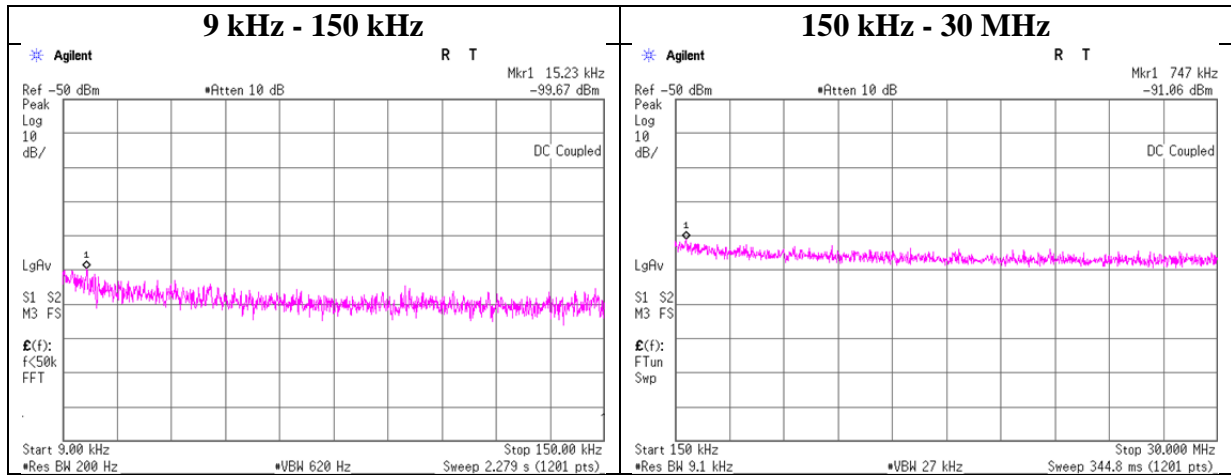

Frequency [kHz]	Reading [dBm]	Cable Loss [dB]	Attenuator Loss [dB]	Antenna Gain [dBi]	N (Number of Output)	EIRP [dBm]	Distance [m]	Ground bounce [dB]	E (field strength) [dBuV/m]	Limit [dBuV/m]	Margin [dB]	Remark
15.23	-99.7	1.03	9.9	3.3	1	-85.4	300	6.0	-24.1	43.9	68.0	
747.00	-91.1	1.39	9.9	3.3	1	-76.5	30	6.0	4.8	30.1	25.3	

$E = \text{EIRP} - 20 \log(D) + \text{Ground bounce} + 104.8 \text{ [dBuV/m]}$

$\text{EIRP} = \text{Reading} + \text{Cable Loss} + \text{Attenuator Loss} + \text{Antenna Gain} + 10 * \log(N)$

UL Japan, Inc.

Ise EMC Lab.

4383-326 Asama-cho, Ise-shi, Mie-ken 516-0021 JAPAN

Telephone : +81 596 24 8999

Facsimile : +81 596 24 8124

Power Density

Test place Ise EMC Lab. No.6 Measurement Room
Report No. 11394939H
Date August 4, 2016
Temperature / Humidity 23 deg. C / 51 % RH
Engineer Hiroyuki Furutaka
Mode Tx

11b

Freq. [MHz]	Reading [dBm]	Cable Loss [dB]	Atten. Loss [dB]	Result [dBm]	Limit [dBm]	Margin [dB]
2412.00	-13.06	2.36	10.08	-0.62	8.00	8.62
2437.00	-12.41	2.37	10.08	0.04	8.00	7.96
2462.00	-12.12	2.37	10.08	0.33	8.00	7.67

11g

Freq. [MHz]	Reading [dBm]	Cable Loss [dB]	Atten. Loss [dB]	Result [dBm]	Limit [dBm]	Margin [dB]
2412.00	-28.26	2.36	10.08	-15.82	8.00	23.82
2437.00	-29.25	2.37	10.08	-16.80	8.00	24.80
2462.00	-28.97	2.37	10.08	-16.52	8.00	24.52

11n-20

Freq. [MHz]	Reading [dBm]	Cable Loss [dB]	Atten. Loss [dB]	Result [dBm]	Limit [dBm]	Margin [dB]
2412.00	-31.08	2.36	10.08	-18.64	8.00	26.64
2437.00	-31.58	2.37	10.08	-19.13	8.00	27.13
2462.00	-31.06	2.37	10.08	-18.61	8.00	26.61

Sample Calculation:

Result = Reading + Cable Loss (including the cable(s) customer supplied) + Attenuator

Power Density

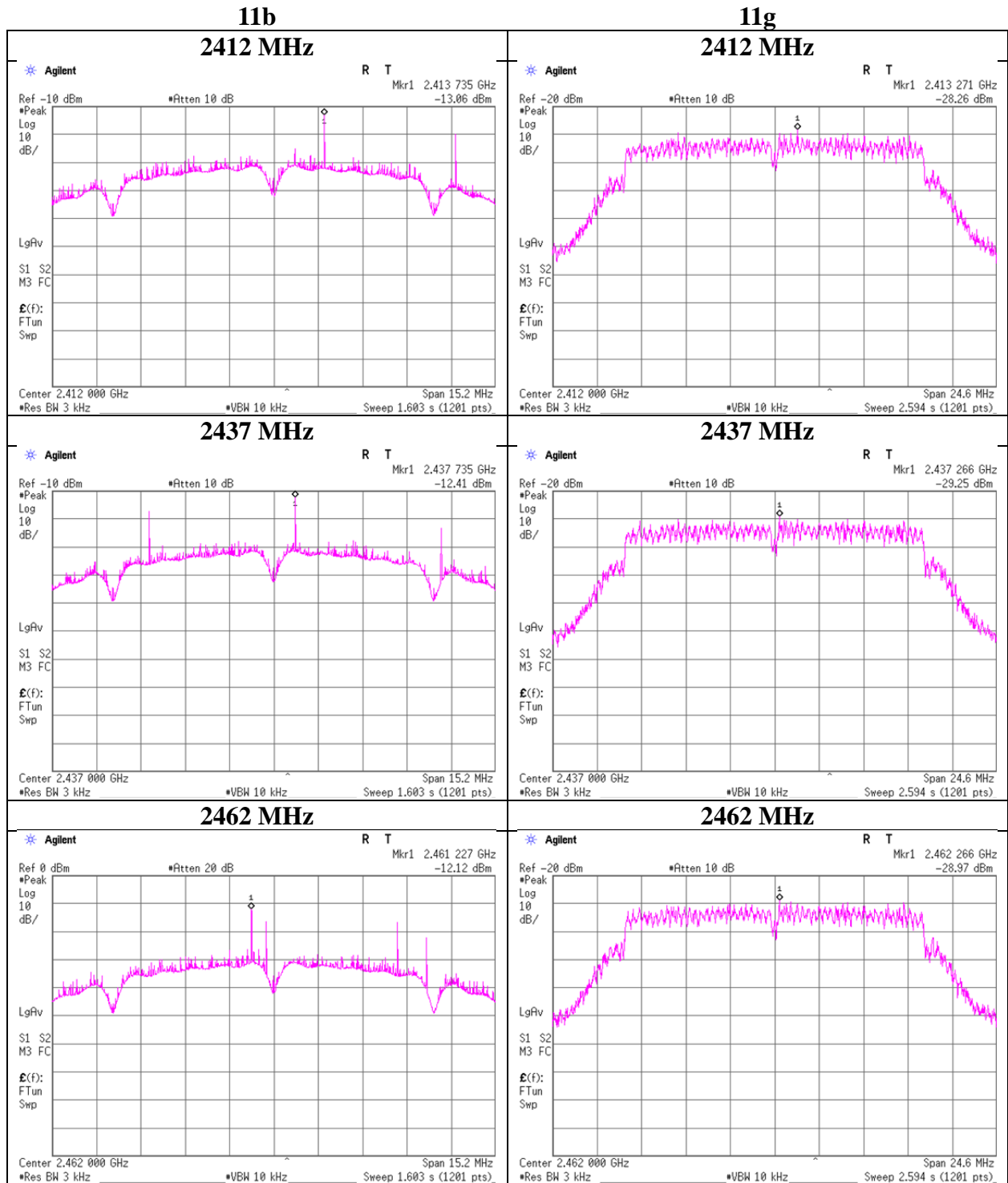

UL Japan, Inc.

Ise EMC Lab.

4383-326 Asama-cho, Ise-shi, Mie-ken 516-0021 JAPAN

Telephone : +81 596 24 8999

Facsimile : +81 596 24 8124

Power Density

11n-20

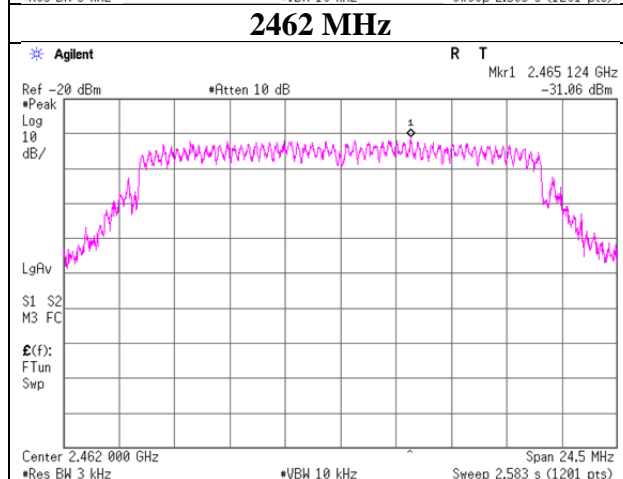
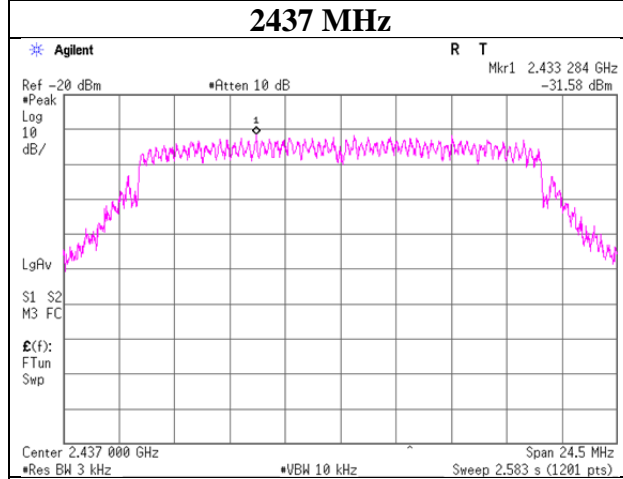
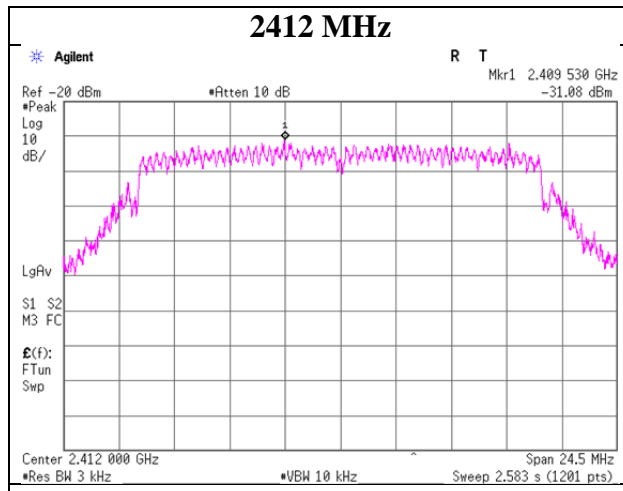

UL Japan, Inc.

Ise EMC Lab.

4383-326 Asama-cho, Ise-shi, Mie-ken 516-0021 JAPAN

Telephone : +81 596 24 8999

Facsimile : +81 596 24 8124

99% Occupied Bandwidth

Test place	Ise EMC Lab. No.6 Measurement Room
Report No.	11394939H
Date	August 4, 2016
Temperature / Humidity	23 deg. C / 51 % RH
Engineer	Hiroyuki Furutaka
Mode	Tx

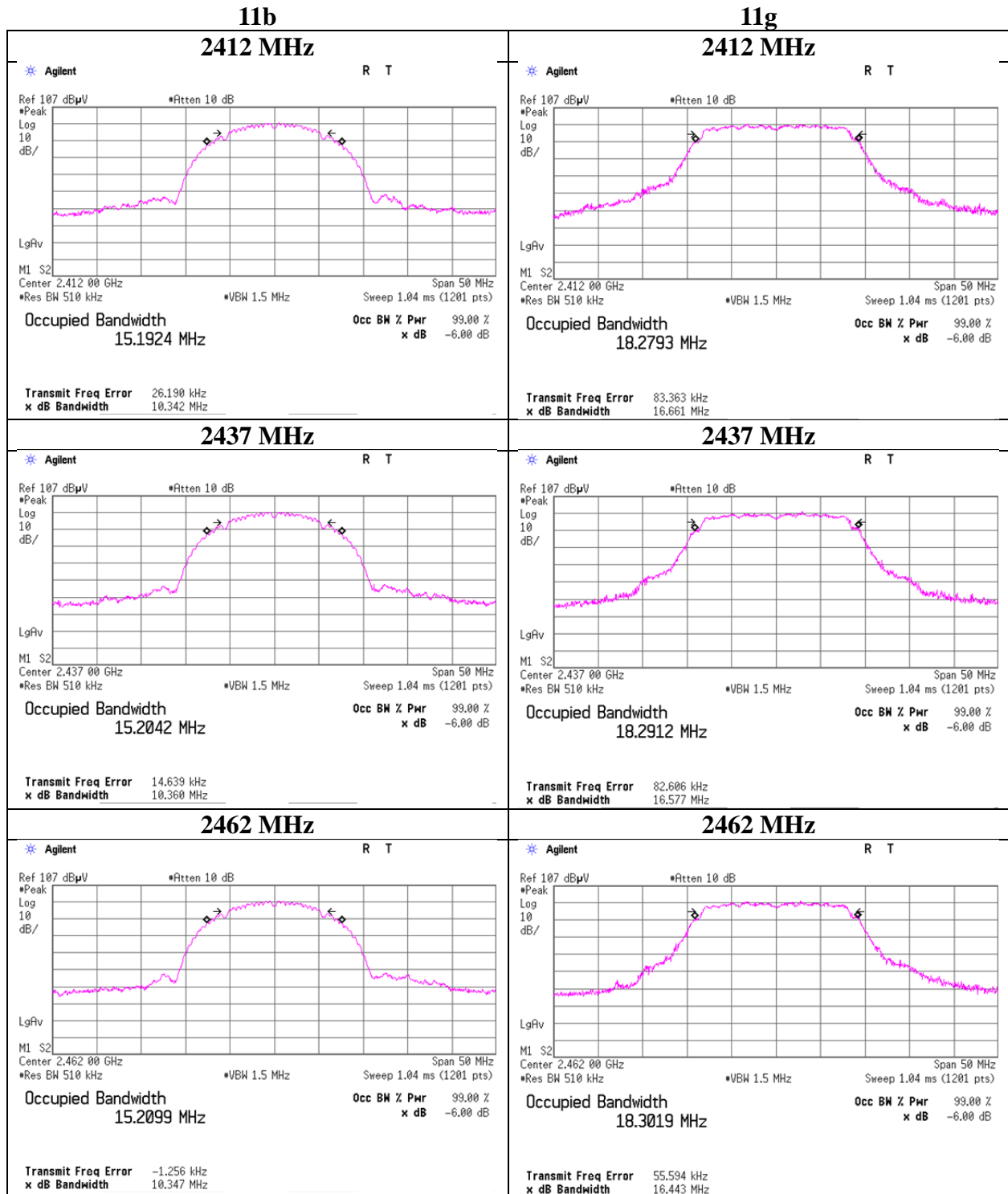

99% Occupied Bandwidth

Test place	Ise EMC Lab. No.6 Measurement Room
Report No.	11394939H
Date	August 4, 2016
Temperature / Humidity	23 deg. C / 51 % RH
Engineer	Hiroyuki Furutaka
Mode	Tx

11n-20

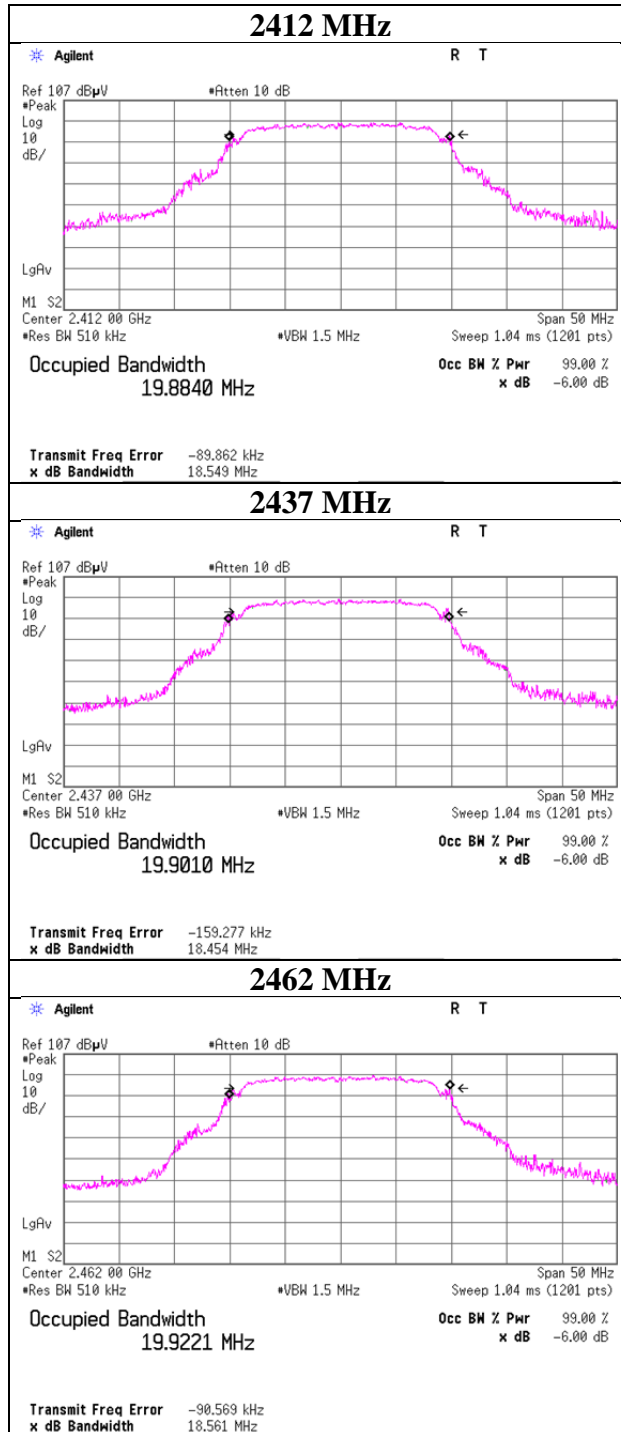

UL Japan, Inc.

Ise EMC Lab.

4383-326 Asama-cho, Ise-shi, Mie-ken 516-0021 JAPAN

Telephone : +81 596 24 8999

Facsimile : +81 596 24 8124

APPENDIX 2: Test instruments

Test equipment

Control No.	Instrument	Manufacturer	Model No	Serial No	Test Item	Calibration Date * Interval(month)
MAEC-04	Semi Anechoic Chamber(NSA)	TDK	Semi Anechoic Chamber 3m	DA-10005	RE	2015/10/02 * 12
MOS-15	Thermo-Hygrometer	Custom	CTH-180	1501	RE	2016/01/21 * 12
MJM-26	Measure	KOMELON	KMC-36	-	RE	-
COTS-MEMI	EMI measurement program	TSJ	TEPTO-DV	-	RE	-
MSA-14	Spectrum Analyzer	Agilent	E4440A	MY48250080	RE	2015/10/07 * 12
MHA-21	Horn Antenna 1-18GHz	Schwarzbeck	BBHA9120D	9120D-557	RE	2015/08/10 * 12
MCC-141	Microwave Cable	Junkosha	MWX221	1305S002R(1m) / 1405S146(5m)	RE	2016/06/21 * 12
MPA-12	MicroWave System Amplifier	Agilent	83017A	00650	RE	2015/10/01 * 12
MMM-10	DIGITAL HiTESTER	Hioki	3805	051201148	RE	2016/01/18 * 12
MHF-26	High Pass Filter 3.5-18.0GHz	UL Japan	HPF SELECTOR	002	RE	2015/09/17 * 12
MRENT-130	Spectrum Analyzer	Agilent	E4440A	MY46187750	AT	2016/06/03 * 12
MPM-16	Power Meter	Agilent	8990B	MY51000271	AT	2016/04/07 * 12
MCC-137	Microwave cable	HUBER+SUHNER	SUCOFLEX 102	37954/2	AT	2015/10/08 * 12
MPSE-22	Power sensor	Agilent	N1923A	MY54070003	AT	2016/04/07 * 12
MAT-20	Attenuator(10dB)(above 1 GHz)	HIROSE ELECTRIC CO.,LTD.	AT-110	-	AT	2016/01/08 * 12
MAT-10	Attenuator(10dB)	Weinschel Corp	2	BL1173	AT	2015/11/10 * 12
MCC-38	Coaxial Cable	UL Japan	-	-	AT	2015/12/07 * 12
MOS-13	Thermo-Hygrometer	Custom	CTH-180	1301	RE	2016/01/21 * 12
MAEC-03	Semi Anechoic Chamber(NSA)	TDK	Semi Anechoic Chamber 3m	DA-10005	RE	2015/10/01 * 12
MJM-16	Measure	KOMELON	KMC-36	-	RE	-
MSA-03	Spectrum Analyzer	Agilent	E4448A	MY44020357	RE	2016/05/19 * 12
MCC-167	Microwave Cable	Junkosha	MWX221	1404S374(1m) / 1405S074(5m)	RE	2016/05/20 * 12
MPA-11	MicroWave System Amplifier	Agilent	83017A	MY39500779	RE	2016/03/24 * 12
MHA-16	Horn Antenna 15-40GHz	Schwarzbeck	BBHA9170	BBHA9170306	RE	2016/05/29 * 12
MMM-08	DIGITAL HiTESTER	Hioki	3805	051201197	RE	2016/01/13 * 12
MSA-16	Spectrum Analyzer	Agilent	E4440A	MY46186390	RE	2016/02/08 * 12
MTR-08	Test Receiver	Rohde & Schwarz	ESCI	100767	RE	2015/09/02 * 12
MBA-03	Biconical Antenna	Schwarzbeck	BBA9106	1915	RE	2015/10/11 * 12
MLA-22	Logperiodic Antenna(200-1000MHz)	Schwarzbeck	VUSLP9111B	911B-191	RE	2016/01/30 * 12
MCC-51	Coaxial cable	UL Japan	-	-	RE	2016/07/26 * 12
MAT-70	Attenuator(6dB)	Agilent	8491A-006	MY52460153	RE	2016/04/05 * 12
MPA-13	Pre Amplifier	SONOMA INSTRUMENT	310	260834	RE	2016/03/24 * 12

The expiration date of the calibration is the end of the expired month.

All equipment is calibrated with valid calibrations. Each measurement data is traceable to the national or international standards.

As for some calibrations performed after the tested dates, those test equipment have been controlled by means of an unbroken chains of calibrations.

**Test Item: RE: Radiated Emission test
AT: Antenna Terminal Conducted test**

UL Japan, Inc.

Ise EMC Lab.

4383-326 Asama-cho, Ise-shi, Mie-ken 516-0021 JAPAN

Telephone : +81 596 24 8999

Facsimile : +81 596 24 8124