



RADIO TEST REPORT

Test Report No. : 11394939H-B-R1

Applicant : MITSUBISHI ELECTRIC CORPORATION SANDA WORKS

Type of Equipment : HEADUNIT A-ENTRY

Model No. : NTG5.5HUE

FCC ID : UJHNTG55HUE

Test regulation : FCC Part 15 Subpart C: 2016 (Bluetooth Part)

Test Result : Complied

1. This test report shall not be reproduced in full or partial, without the written approval of UL Japan, Inc.
2. The results in this report apply only to the sample tested.
3. This sample tested is in compliance with the above regulation.
4. The test results in this report are traceable to the national or international standards.
5. This test report must not be used by the customer to claim product certification, approval, or endorsement by NVLAP, NIST, or any agency of the Federal Government.
6. This test report covers Radio technical requirements. It does not cover administrative issues such as Manual or non-Radio test related Requirements. (if applicable)
7. This report is a revised version of 11394939H-B. 11394939H-B is replaced with this report.

Date of test: August 3 to 24, 2016

Representative test engineer:

Hiroyuki Furutaka

Engineer
Consumer Technology Division

Approved by:

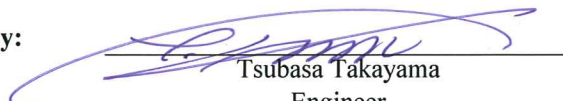
Tsubasa Takayama

Engineer
Consumer Technology Division



NVLAP LAB CODE: 200572-0

This laboratory is accredited by the NVLAP LAB CODE 200572-0, U.S.A. The tests reported herein have been performed in accordance with its terms of accreditation. *As for the range of Accreditation in NVLAP, you may refer to the WEB address, http://japan.ul.com/resources/emc_accredited/

UL Japan, Inc.

Ise EMC Lab.

4383-326 Asama-cho, Ise-shi, Mie-ken 516-0021 JAPAN

Telephone : +81 596 24 8999

Facsimile : +81 596 24 8124

CONTENTS	PAGE
SECTION 1: Customer information.....	4
SECTION 2: Equipment under test (E.U.T.).....	4
SECTION 3: Test specification, procedures & results.....	5
SECTION 4: Operation of E.U.T. during testing.....	8
SECTION 5: Radiated Spurious Emission	11
SECTION 6: Antenna Terminal Conducted Tests.....	13
APPENDIX 1: Test data	14
20dB Bandwidth and Carrier Frequency Separation.....	14
Number of Hopping Frequency	17
Dwell time.....	19
Maximum Peak Output Power	22
Average Output Power	23
Radiated Spurious Emission	25
Conducted Spurious Emission	38
Conducted Emission Band Edge compliance	44
99%Occupied Bandwidth	46
APPENDIX 2: Test instruments	48
APPENDIX 3: Photographs of test setup	49
Radiated Spurious Emission	49
Worst Case Position	50

SECTION 1: Customer information

Company Name : MITSUBISHI ELECTRIC CORPORATION SANDA WORKS
Address : 2-3-33, Miwa, Sanda-city, Hyogo, 669-1513, Japan
Telephone Number : +81-79-559-3607
Facsimile Number : +81-79-559-3875
Contact Person : Harutaka Nomura

SECTION 2: Equipment under test (E.U.T.)

2.1 Identification of E.U.T.

Type of Equipment : HEADUNIT A-ENTRY
Model No. : NTG5.5HUE
Serial No. : Refer to Section 4, Clause 4.2
Rating : DC 12 V
Receipt Date of Sample : August 1, 2016
Country of Mass-production : Thailand
Condition of EUT : Production prototype
(Not for Sale: This sample is equivalent to mass-produced items.)
Modification of EUT : No Modification by the test lab

2.2 Product Description

Model: NTG5.5HUE (referred to as the EUT in this report) is a HEADUNIT A-ENTRY.

General Specification

Clock frequency(ies) in the system : 1.4 GHz, 40 MHz, 26 MHz

Radio Specification

	IEEE802.11b	IEEE802.11g/n (20 M band)	Bluetooth Ver.3.0 with EDR function
Frequency of operation	2412 MHz - 2462 MHz	2412 MHz - 2462 MHz	2402 MHz - 2480 MHz *1)
Type of modulation	DSSS (CCK, DQPSK, DBPSK)	OFDM-CCK (64QAM, 16QAM, QPSK, BPSK)	FHSS (GFSK, $\pi/4$ -DQPSK, 8-DPSK)
Channel spacing	5 MHz		1 MHz
Antenna type	Printed patch Antenna		Dipole Pattern Antenna
Antenna Connector type	FAKRA		PSE-LP2
Antenna Gain	3.3 dBi		2.32 dBi

*1) This test report applies for Bluetooth Ver.3.0 with EDR function

	GPS/GLONASS
Frequency of operation	GPS: 1575.42 MHz GLONASS: 1597.55-1605.89 MHz
Type of modulation	GPS: BPSK GLONASS: BPSK
Channel spacing	GLONASS: 0.5625 MHz
Antenna type	Active antenna
Antenna Connector type	FAKRA
Antenna Gain	25 dBi

UL Japan, Inc.

Ise EMC Lab.

4383-326 Asama-cho, Ise-shi, Mie-ken 516-0021 JAPAN

Telephone : +81 596 24 8999

Facsimile : +81 596 24 8124

SECTION 3: Test specification, procedures & results

3.1 Test Specification

Test Specification : FCC Part 15 Subpart C
FCC part 15 final revised on April 6, 2016.

Title : FCC 47CFR Part15 Radio Frequency Device Subpart C Intentional Radiators
Section 15.207 Conducted limits
Section 15.247 Operation within the bands 902-928MHz,
2400-2483.5MHz, and 5725-5850MHz

3.2 Procedures and results

Item	Test Procedure	Specification	Worst Margin	Results	Remarks
Conducted Emission	FCC: ANSI C63.10-2013 6. Standard test methods IC: RSS-Gen 8.8	FCC: Section 15.207 IC: RSS-Gen 8.8	N/A	N/A *2)	-
Carrier Frequency Separation	FCC: FCC Public Notice DA 00-705 IC: -	FCC: Section15.247(a)(1) IC: RSS-247 5.1 (2)	See data.	Complied	Conducted
20dB Bandwidth	FCC: FCC Public Notice DA 00-705 IC: -	FCC: Section15.247(a)(1) IC: RSS-247 5.1 (1)		Complied	Conducted
Number of Hopping Frequency	FCC: FCC Public Notice DA 00-705 IC: -	FCC: Section15.247(a)(1)(iii) IC: RSS-247 5.1 (4)		Complied	Conducted
Dwell time	FCC: FCC Public Notice DA 00-705 IC: -	FCC: Section15.247(a)(1)(iii) IC: RSS-247 5.1 (4)		Complied	Conducted
Maximum Peak Output Power	FCC: FCC Public Notice DA 00-705 IC: RSS-Gen 6.12	FCC: Section15.247(a)(b)(1) IC: RSS-247 5.4 (2)		Complied	Conducted
Spurious Emission & Band Edge Compliance	FCC: FCC Public Notice DA 00-705 IC: RSS-Gen 6.13	FCC: Section15.247(d) IC: RSS-247 5.5 RSS-Gen 8.9 RSS-Gen 8.10	2.0 dB 884.738 MHz, QP, Horizontal	Complied	Conducted/ Radiated (above 30 MHz) *1)

Note: UL Japan, Inc.'s EMI Work Procedures No. 13-EM-W0420 and 13-EM-W0422.

*1) Radiated test was selected over 30 MHz based on section 15.247(d).

*2) The test is not applicable since the EUT is not the device that is designed to be connected to the public utility (AC) power line.

* In case any questions arise about test procedure, ANSI C63.10: 2013 is also referred.

FCC 15.31 (e)

The EUT provides stable voltage (DC 3.3 V) constantly to the wireless transmitter regardless of input voltage.

Instead of a new battery, DC power supply was used for the test.

That does not affect the test result, therefore the EUT complies with the requirement.

FCC Part 15.203 Antenna requirement

It is impossible for end users to replace the antenna, because the antenna is mounted inside of the vehicle. Therefore, the equipment complies with the antenna requirement of Section 15.203.

UL Japan, Inc.

Ise EMC Lab.

4383-326 Asama-cho, Ise-shi, Mie-ken 516-0021 JAPAN

Telephone : +81 596 24 8999

Facsimile : +81 596 24 8124

3.3 Addition to standard

Item	Test Procedure	Specification	Worst margin	Results	Remarks
99% Occupied Bandwidth	IC: RSS-Gen 6.6	IC: -	N/A	-	Conducted

Other than above, no addition, exclusion nor deviation has been made from the standard.

3.4 Uncertainty

EMI

The following uncertainties have been calculated to provide a confidence level of 95 % using a coverage factor $k = 2$.
Ise EMC Lab.

Antenna terminal test Uncertainty (+/-)							
Power meter		Conducted emission and Power density			Conducted emission		Channel power
Below 1 GHz	Above 1 GHz	Below 1 GHz	1 GHz - 3 GHz	3 GHz - 18 GHz	18 GHz - 26.5 GHz	26.5 GHz - 40 GHz	
0.9 dB	1.0 dB	1.4 dB	1.7 dB	2.8 dB	2.8 dB	2.9 dB	2.6 dB

Test distance	Radiated emission (+/-) 9 kHz - 30 MHz
3m	3.8 dB
10m	3.7 dB

Polarity	Radiated emission (Below 1GHz)			
	(3 m*) (+/-)		(10 m*) (+/-)	
	30 - 200 MHz	200 - 1000MHz	30 - 200 MHz	200 - 1000MHz
Horizontal	5.0 dB	5.3 dB	5.0 dB	5.0 dB
Vertical	4.7 dB	5.9 dB	5.0 dB	5.1 dB

Radiated emission (Above 1GHz)				
(3 m*) (+/-)		(1 m*) (+/-)		(10 m*) (+/-)
1 - 6GHz	6 - 18GHz	10 - 26.5 GHz	26.5 - 40GHz	1 - 18 GHz
5.2 dB	5.4 dB	5.5 dB	5.5 dB	5.4 dB

*Measurement distance

Radiated emission test

The data listed in this report meets the limits unless the uncertainty is taken into consideration.

3.5 Test Location

UL Japan, Inc. Ise EMC Lab. *NVLAP Lab. code: 200572-0
4383-326 Asama-cho, Ise-shi, Mie-ken 516-0021 JAPAN
Telephone: +81 596 24 8999, Facsimile: +81 596 24 8124

Test site	IC Registration Number	Width x Depth x Height (m)	Size of reference ground plane (m) / horizontal conducting plane	Other rooms	Maximum measurement distance
No.1 semi-anechoic chamber	2973C-1	19.2 x 11.2 x 7.7	7.0 x 6.0	No.1 Power source room	10 m
No.2 semi-anechoic chamber	2973C-2	7.5 x 5.8 x 5.2	4.0 x 4.0	-	3 m
No.3 semi-anechoic chamber	2973C-3	12.0 x 8.5 x 5.9	6.8 x 5.75	No.3 Preparation room	3 m
No.3 shielded room	-	4.0 x 6.0 x 2.7	N/A	-	-
No.4 semi-anechoic chamber	2973C-4	12.0 x 8.5 x 5.9	6.8 x 5.75	No.4 Preparation room	3 m
No.4 shielded room	-	4.0 x 6.0 x 2.7	N/A	-	-
No.5 semi-anechoic chamber	-	6.0 x 6.0 x 3.9	6.0 x 6.0	-	-
No.6 shielded room	-	4.0 x 4.5 x 2.7	4.0 x 4.5	-	-
No.6 measurement room	-	4.75 x 5.4 x 3.0	4.75 x 4.15	-	-
No.7 shielded room	-	4.7 x 7.5 x 2.7	4.7 x 7.5	-	-
No.8 measurement room	-	3.1 x 5.0 x 2.7	N/A	-	-
No.9 measurement room	-	8.8 x 4.6 x 2.8	2.4 x 2.4	-	-
No.11 measurement room	-	6.2 x 4.7 x 3.0	4.8 x 4.6	-	-

* Size of vertical conducting plane (for Conducted Emission test) : 2.0 m x 2.0 m for No.1, No.2, No.3, and No.4 semi-anechoic chambers and No.3 and No.4 shielded rooms.

3.6 Test data, Test instruments, and Test set up

Refer to APPENDIX.

UL Japan, Inc.

Ise EMC Lab.

4383-326 Asama-cho, Ise-shi, Mie-ken 516-0021 JAPAN

Telephone : +81 596 24 8999

Facsimile : +81 596 24 8124

SECTION 4: Operation of E.U.T. during testing

4.1 Operating Mode(s)

Bluetooth (BT): Transmitting (Tx), Payload: PRBS9

Details of Operating Mode(s)

Test Item	Mode	Tested frequency
Spurious Emission (Conducted/Radiated)	Tx (Hopping Off) DH5, 3DH5	2402 MHz 2441 MHz 2480 MHz
Carrier Frequency Separation	Tx (Hopping On) DH5, 3DH5	2402 MHz 2441 MHz 2480 MHz
20dB Bandwidth	Tx (Hopping Off) DH5, 3DH5	2402 MHz 2441 MHz 2480 MHz
Number of Hopping Frequency	Tx (Hopping On) DH5, 3DH5	-
Dwell time	Tx (Hopping On), -DH1, DH3, DH5 -3DH1, 3DH3, 3DH5	-
Maximum Peak Output Power	Tx (Hopping Off) DH5, 2DH5, 3DH5	2402 MHz 2441 MHz 2480 MHz
Band Edge Compliance (Conducted)	Tx DH5, 3DH5 -Hopping On -Hopping Off	2402 MHz 2480 MHz
99% Occupied Bandwidth	Tx DH5, 3DH5 -Hopping On -Hopping Off	2402 MHz 2441 MHz 2480 MHz
<p>*As a result of preliminary test, the formal test was performed with the above modes, which had the maximum payload length (except Dwell time test)</p> <p>*2DH mode (2Mb/s EDR: pi/4DQPSK) was excluded for other tests than power measurement by using 3DH mode (3 Mb/s EDR: 8DPSK) as a representative.</p> <p>* It is considered that the non-tested packet type (e.g. inquiry) can be omitted as it is complied with above all test items based on Bluetooth Core specification.</p> <p>*EUT has the power settings by the software as follows; - Power Setting: default - Software: E162.0 *This setting of software is the worst case. Any conditions under the normal use do not exceed the condition of setting. In addition, end users cannot change the settings of the output power of the product.</p>		

4.2 Configuration and peripherals

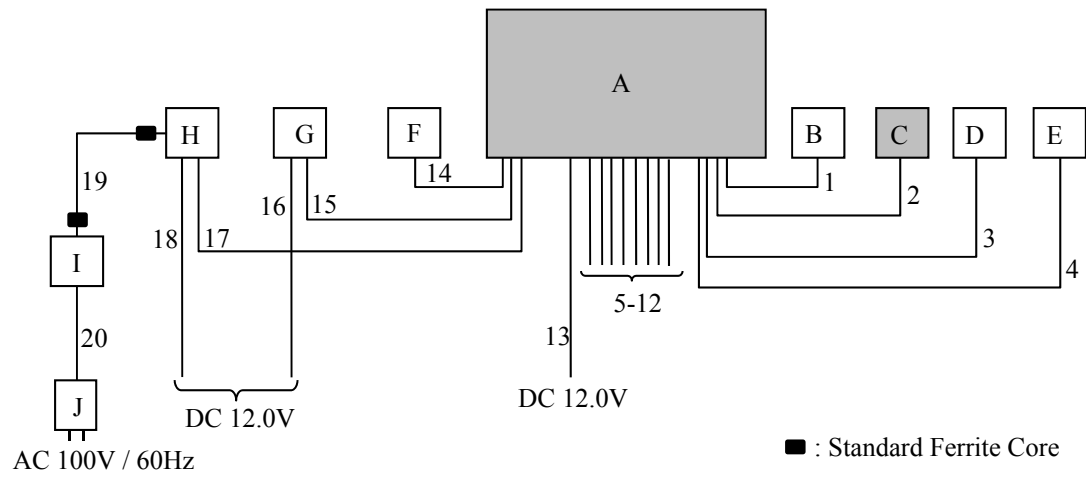

* Cabling and setup(s) were taken into consideration and test data was taken under worse case conditions.

Description of EUT and Support equipment

No.	Item	Model number	Serial number	Manufacturer	Remarks
A	HEADUNIT A-ENTRY	NTG5.5HUE	MED260G5237 070	mitsubishi electric corporation sanda works	EUT
B	WLAN Antenna	AG201-002	ZGS001	WiSi	-
C	BT Antenna	050 978-A	23/13	WiSi	EUT
D	GPS Antenna	-	-	mitsubishi electric corporation sanda works	-
E	USB Memory	PD-07 WH8GB	-	KINGMAX	-
F	Dummy Load	-	-	mitsubishi electric corporation sanda works	-
G	Controller	A 166 900 65 14	4445	Mercedes-Benz	-
H	HSVL Converter	-	-	mitsubishi electric corporation sanda works	-
I	Display	LCD-8000VH	1504U-09	Century	-
J	Switching Power Supply	UWP305S-0510 BC	1503-0000401	UNIWAYPO	-

List of cables used

No.	Name	Length (m)	Shield		Remarks
			Cable	Connector	
1	WLAN Antenna Cable	1.5	Shielded	Shielded	-
2	BT Antenna Cable	0.5	Shielded	Shielded	-
3	GPS Antenna Cable	5.0	Shielded	Shielded	-
4	USB Cable	1.0	Shielded	Shielded	-
5	USB Cable	1.0	Shielded	Shielded	-
6	Dummy Cable	1.0	Shielded	Shielded	-
7	Dummy Cable	1.0	Shielded	Shielded	-
8	Dummy Cable	1.0	Shielded	Shielded	-
9	Dummy Cable	1.0	Shielded	Shielded	-
10	Dummy Cable	1.0	Shielded	Shielded	-
11	LVDS Cable	1.0	Shielded	Shielded	-
12	Signal Cable	1.0	Unshielded	Unshielded	-
13	DC Cable	3.5	Unshielded	Unshielded	-
14	Speaker Cable	0.5	Unshielded	Unshielded	-
15	Signal Cable	1.8	Unshielded	Unshielded	-
16	DC Cable	2.0	Unshielded	Unshielded	-
17	LVDS Cable	1.0	Shielded	Shielded	-
18	DC Cable	3.0	Unshielded	Unshielded	-
19	RGB Cable	1.8	Shielded	Shielded	-
20	USB Cable	1.5	Shielded	Shielded	-

UL Japan, Inc.

Ise EMC Lab.

4383-326 Asama-cho, Ise-shi, Mie-ken 516-0021 JAPAN

Telephone : +81 596 24 8999

Facsimile : +81 596 24 8124

SECTION 5: Radiated Spurious Emission

Test Procedure

[For below 1GHz]

EUT was placed on a urethane platform of nominal size, 0.5 m by 1.0 m, raised 0.8 m above the conducting ground plane. The Radiated Electric Field Strength has been measured in a Semi Anechoic Chamber with a ground plane.

[For above 1GHz]

EUT was placed on a urethane platform of nominal size, 0.5 m by 0.5 m, raised 1.5 m above the conducting ground plane.

The Radiated Electric Field Strength has been measured in a Semi Anechoic Chamber with absorbent materials lined on a ground plane.

The height of the measuring antenna varied between 1 and 4 m and EUT was rotated a full revolution in order to obtain the maximum value of the electric field strength.

The measurements were performed for both vertical and horizontal antenna polarization with the Test Receiver, or the Spectrum Analyzer.

The measurements were made with the following detector function of the test receiver and the Spectrum analyzer (in linear mode).

The test was made with the detector (RBW/VBW) in the following table.

When using Spectrum analyzer, the test was made with adjusting span to zero by using peak hold.

Test Antennas are used as below;

Frequency	30 MHz to 200 MHz	200 MHz to 1 GHz	Above 1 GHz
Antenna Type	Biconical	Logperiodic	Horn

In any 100 kHz bandwidth outside the restricted band in which the spread spectrum intentional radiator is operating, the radio frequency power that is produced by the intentional radiator confirmed 20 dB below that in the 100 kHz bandwidth within the band that contains the highest level of the desired power, based on a radiated measurement.

20 dBc was applied to the frequency over the limit of FCC 15.209 / Table 4 of RSS-Gen 8.9 (IC) and outside the restricted band of FCC15.205 / Table 6 of RSS-Gen 8.10 (IC).

Frequency	Below 1 GHz	Above 1 GHz		20 dBc
Instrument used	Test Receiver	Spectrum Analyzer		Spectrum Analyzer
Detector	QP	PK	AV	PK
IF Bandwidth	BW 120 kHz	RBW: 1 MHz VBW: 3 MHz	RBW: 1 MHz VBW: 10 Hz *1)	RBW: 100 kHz VBW: 300 kHz
Test Distance	3 m	3 m*2) (1 GHz – 10 GHz), 1 m*3) (10 GHz – 26.5 GHz)		3 m*2) (1 GHz – 10 GHz), 1 m*3) (10 GHz – 26.5 GHz)

*1) Although DA 00-705 accepts VBW = 10 Hz for AV measurements, it was confirmed that superfluous smoothing was not performed.

*2) Distance Factor: $20 \times \log(4.3 \text{ m}/3.0 \text{ m}) = 3.13 \text{ dB}$

*3) Distance Factor: $20 \times \log(1.0 \text{ m}/3.0 \text{ m}) = -9.5 \text{ dB}$

UL Japan, Inc.

Ise EMC Lab.

4383-326 Asama-cho, Ise-shi, Mie-ken 516-0021 JAPAN

Telephone : +81 596 24 8999

Facsimile : +81 596 24 8124

[BT antenna]

- The carrier level and noise levels were confirmed at each position of X, Y and Z axes of BT antenna to see the position of maximum noise, and the test was made at the position that has the maximum noise.

[HEADUNIT A-ENTRY]

-The test was made on EUT at the normal use position.

The test results and limit are rounded off to one decimal place, so some differences might be observed.

Measurement range : 30 MHz - 26.5 GHz
Test data : APPENDIX
Test result : Pass

UL Japan, Inc.

Ise EMC Lab.

4383-326 Asama-cho, Ise-shi, Mie-ken 516-0021 JAPAN

Telephone : +81 596 24 8999

Facsimile : +81 596 24 8124

SECTION 6: Antenna Terminal Conducted Tests

Test Procedure

The tests were made with below setting connected to the antenna port.

Test	Span	RBW	VBW	Sweep time	Detector	Trace	Instrument used
20dB Bandwidth	3 MHz	30 kHz	100 kHz	Auto	Peak	Max Hold	Spectrum Analyzer
99% Occupied Bandwidth *1)	Enough width to display emission skirts	1 to 5 % of OBW	Three times of RBW	Auto	Peak	Max Hold	Spectrum Analyzer
Maximum Peak Output Power	-	-	-	Auto	Peak Average *2)	-	Power Meter (Sensor: 50MHz BW)
Carrier Frequency Separation	3 MHz	30 kHz	100 kHz	Auto	Peak	Max Hold	Spectrum Analyzer
Number of Hopping Frequency	30 MHz	300 kHz	1 MHz	Auto	Peak	Max Hold	Spectrum Analyzer
Dwell Time	Zero Span	100 kHz, 1 MHz	300 kHz, 3 MHz	As necessary capture the entire dwell time per hopping channel	Peak	Clear Write	Spectrum Analyzer
Conducted Spurious Emission *3)	9 kHz to 150 kHz	200 Hz	620 Hz	Auto	Peak	Max Hold	Spectrum Analyzer
	150 kHz to 30 MHz	9.1 kHz	27 kHz				
	30 MHz to 25 GHz	100 kHz	300 kHz				
Conducted Spurious Emission Band Edge compliance	10 MHz	100 kHz	300 kHz	Auto	Peak	Max Hold	Spectrum Analyzer

*1) Peak hold was applied as Worst-case measurement.

*2) Reference data

*3) In the frequency range below 30MHz, RBW was narrowed to separate the noise contents.

Then, wide-band noise near the limit was checked separately, however the noise was low enough as shown in the chart.

(9 kHz - 150 kHz: RBW = 200Hz, 150 kHz - 30 MHz: RBW = 9.1 kHz).

The test results and limit are rounded off to two decimals place, so some differences might be observed.

Test data : APPENDIX

Test result : Pass

APPENDIX 1: Test data

20dB Bandwidth and Carrier Frequency Separation

Test place Ise EMC Lab. No.6 Measurement Room
Report No. 11394939H
Date August 3, 2016
Temperature / Humidity 24 deg. C / 49 % RH
Engineer Hiroyuki Furutaka
Mode Tx (Hopping on/off) DH5/3DH5

Mode	Freq. [MHz]	20dB Bandwidth [MHz]	Carrier Frequency Separation [MHz]	Limit for Carrier Frequency separation [MHz]
DH5	2402.0	0.958	1.000	≥ 0.639
DH5	2441.0	0.958	1.000	≥ 0.639
DH5	2480.0	0.960	1.000	≥ 0.640
3DH5	2402.0	1.296	1.000	≥ 0.864
3DH5	2441.0	1.299	1.000	≥ 0.866
3DH5	2480.0	1.294	1.000	≥ 0.863

Limit: Two-thirds of 20dB Bandwidth or 25kHz (whichever is greater).

No limit applies to 20dB Bandwidth.

20dB Bandwidth and Carrier Frequency Separation

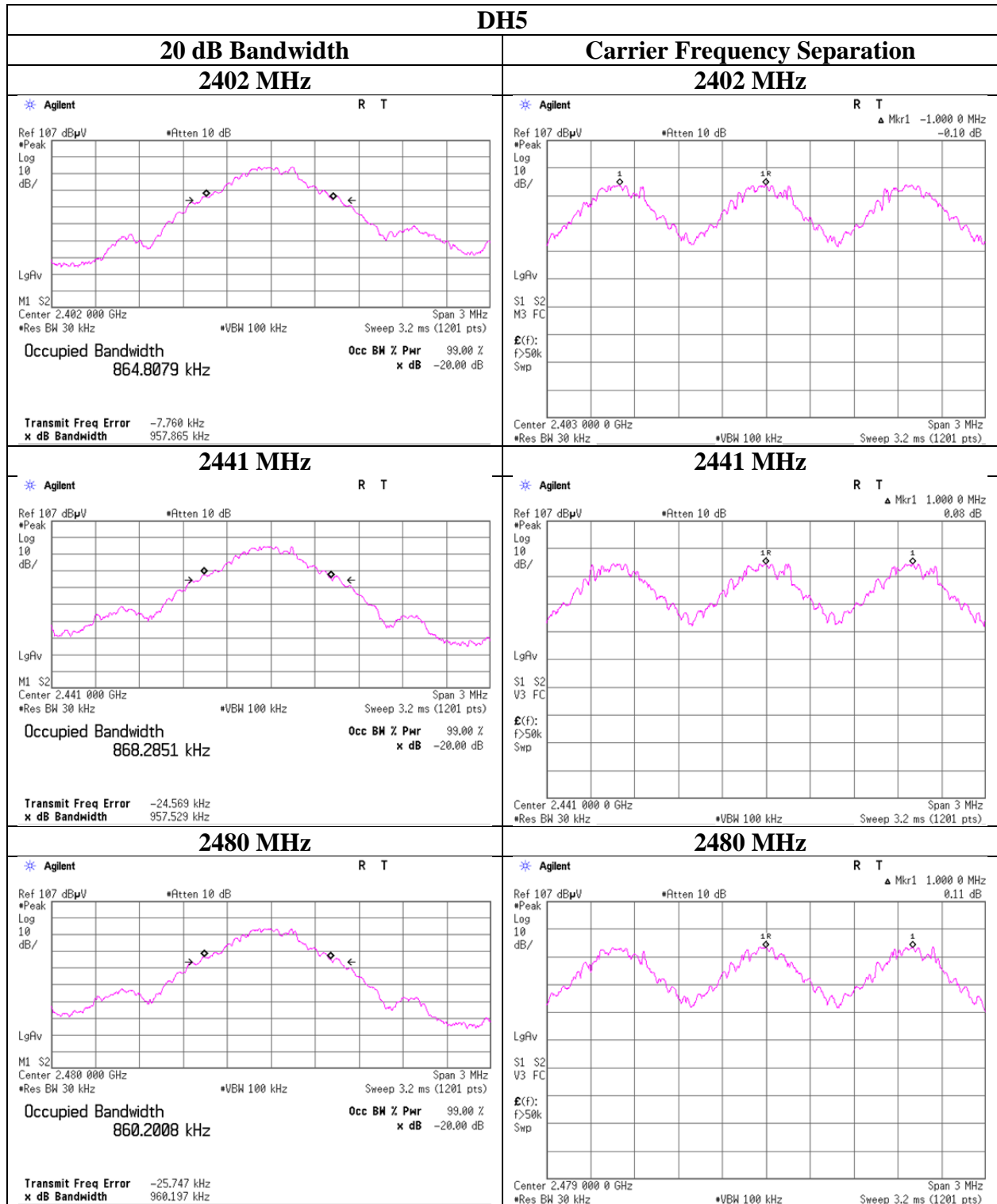

UL Japan, Inc.

Ise EMC Lab.

4383-326 Asama-cho, Ise-shi, Mie-ken 516-0021 JAPAN

Telephone : +81 596 24 8999

Facsimile : +81 596 24 8124

20dB Bandwidth and Carrier Frequency Separation

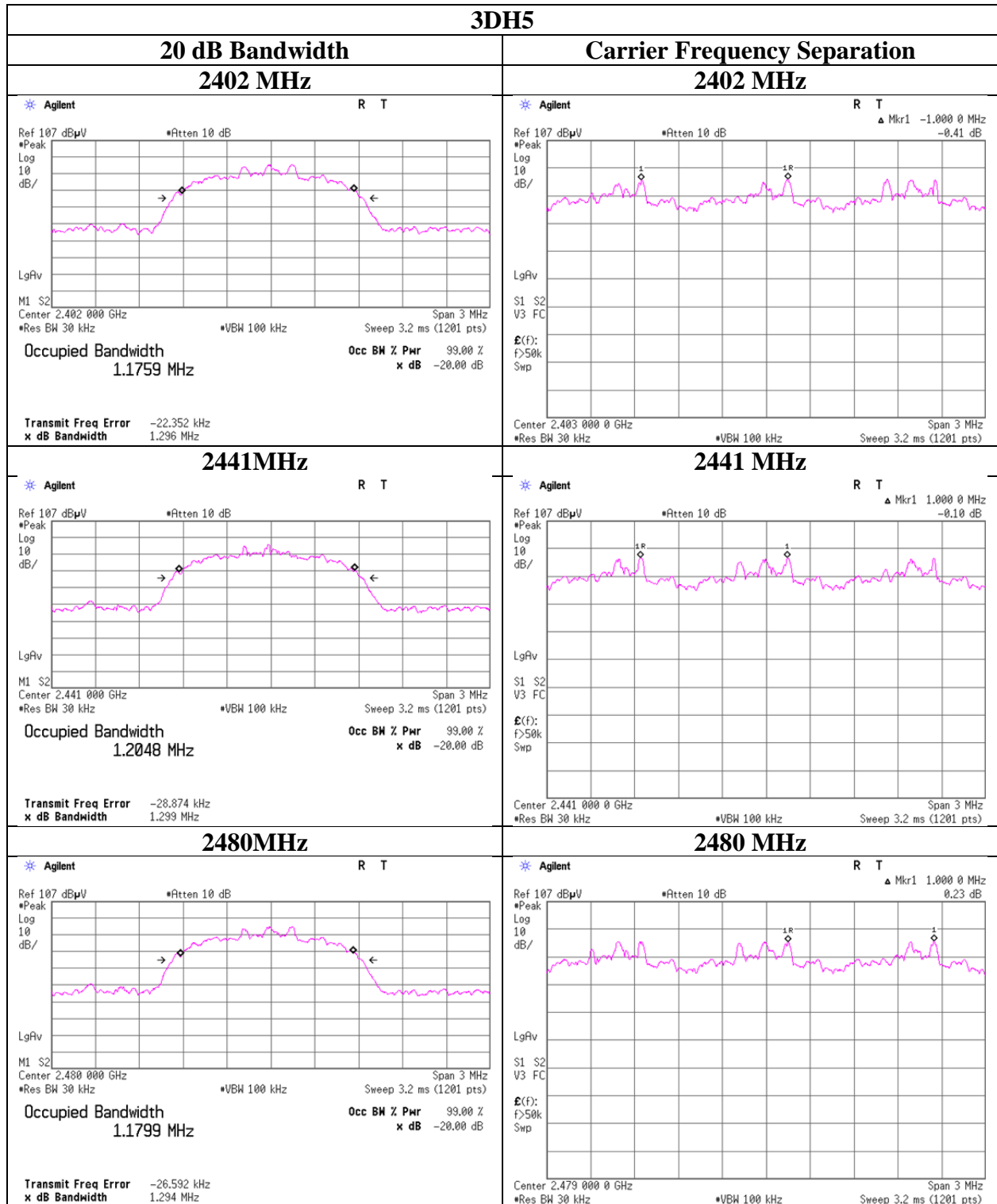

UL Japan, Inc.

Ise EMC Lab.

4383-326 Asama-cho, Ise-shi, Mie-ken 516-0021 JAPAN

Telephone : +81 596 24 8999

Facsimile : +81 596 24 8124

Number of Hopping Frequency

Test place Ise EMC Lab. No.6 Measurement Room
Report No. 11394939H
Date August 3, 2016
Temperature / Humidity 24 deg. C / 49 % RH
Engineer Hiroyuki Furutaka
Mode Tx (Hopping on) DH5/3DH5

Mode	Number of channel [channels]	Limit [channels]
DH5	79	≥ 15
3DH5	79	≥ 15

Test was not performed at AFH mode whose number of hopping channel is 20 channels because this Bluetooth radio is in compliance of Bluetooth Specification.

Number of Hopping Frequency

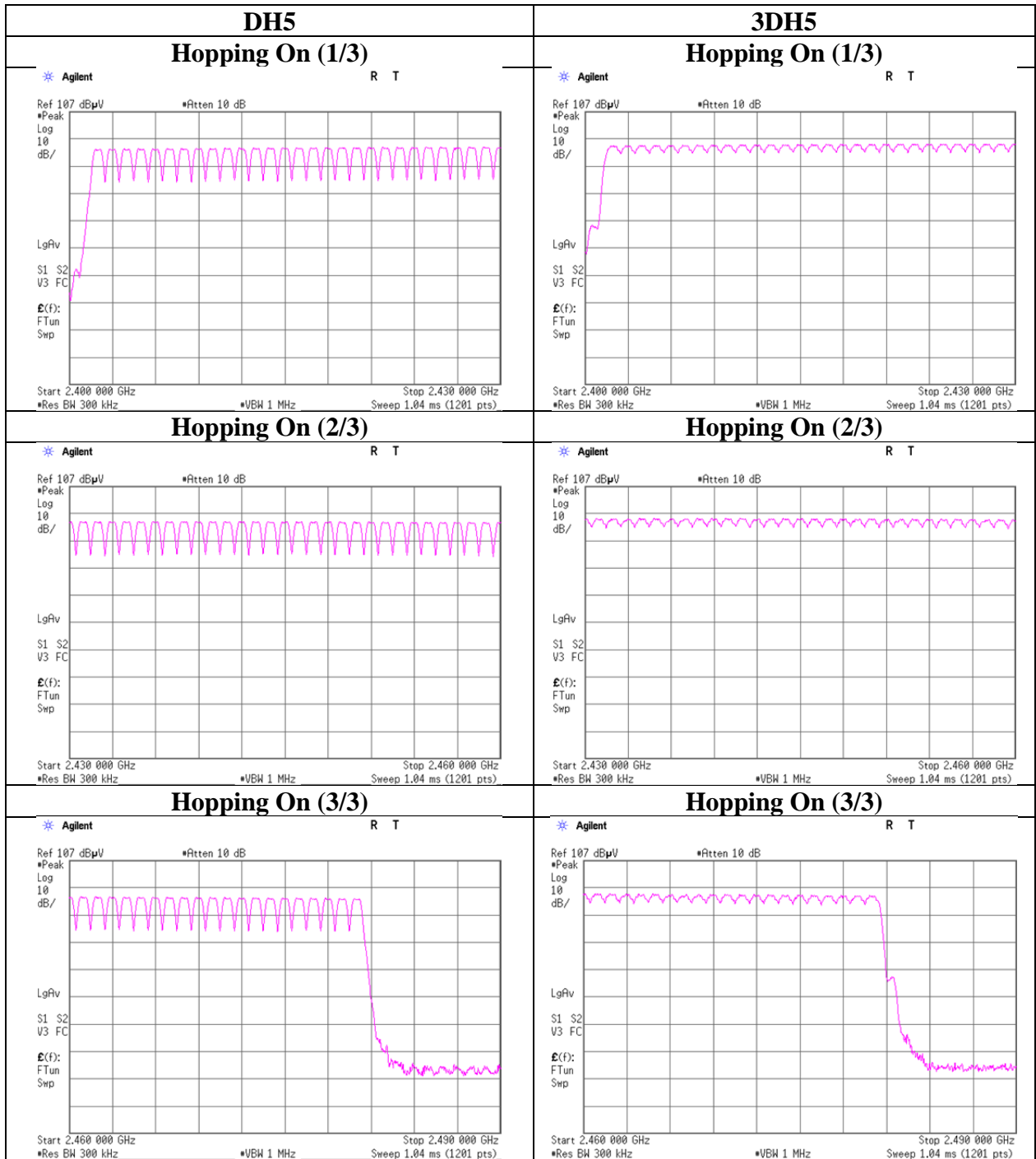

Dwell time

Test place Ise EMC Lab. No.6 Measurement Room
Report No. 11394939H
Date August 3, 2016
Temperature / Humidity 24 deg. C / 49 % RH
Engineer Hiroyuki Furutaka
Mode Tx (Hopping on) DH5/3DH5

Mode	Number of transmission in a 31.6(79 Hopping x 0.4) / 12.8 (32 Hopping x 0.4) second period			Length of transmission [msec]	Result [msec]	Limit [msec]	
DH1	50.6 times /	5 sec. x	31.6 sec. =	320 times	0.427	137	400
DH3	24.8 times /	5 sec. x	31.6 sec. =	157 times	1.696	266	400
DH5	17.0 times /	5 sec. x	31.6 sec. =	108 times	2.943	318	400
3DH1	50.0 times /	5 sec. x	31.6 sec. =	316 times	0.446	141	400
3DH3	25.0 times /	5 sec. x	31.6 sec. =	158 times	1.708	270	400
3DH5	16.8 times /	5 sec. x	31.6 sec. =	107 times	2.957	316	400

Sample Calculation

Result = Number of transmission x Length of transmission

*Average data of 5 tests.(except Inquiry)

Mode	Sampling [times]					Average [times]
	1	2	3	4	5	
DH1	50	51	51	50	51	50.6
DH3	25	24	25	25	25	24.8
DH5	17	17	17	17	17	17
3DH1	50	50	50	50	50	50
3DH3	25	25	25	25	25	25
3DH5	17	16	17	17	17	16.8

Sample Calculation

Average = Summation (Sampling 1 to 5) / 5

This device complies with the Bluetooth protocol for FHSS operation, employing a pseudo random channel selection and hopping rate to ensure that the occupancy time in $N \times 0.4s$, where N is the number of channels being used in the hopping sequence ($20 \leq N \leq 79$), is always less than $0.4s$ regardless of packet size. This is confirmed in the test report for $N = 79$.

Dwell time

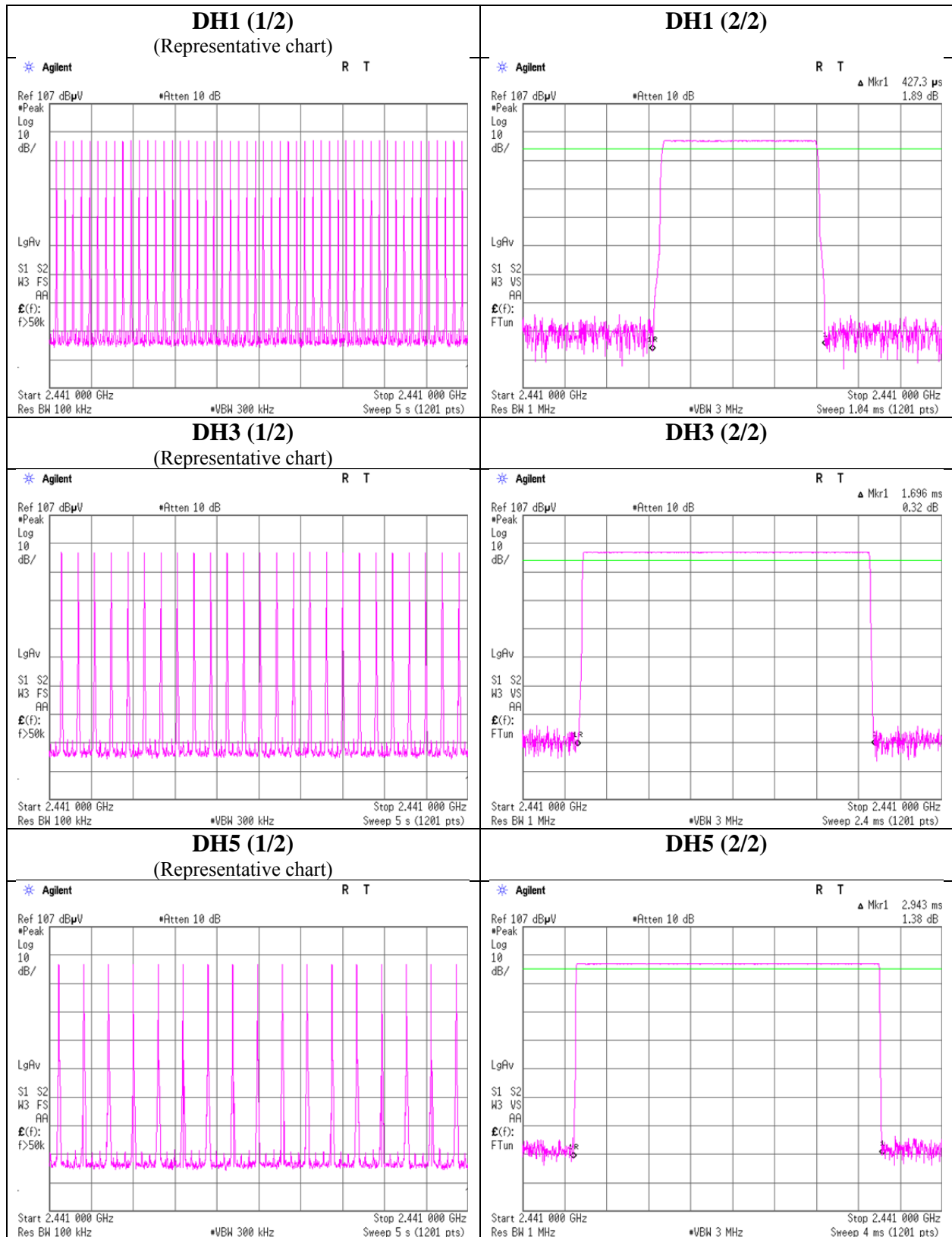

UL Japan, Inc.

Ise EMC Lab.

4383-326 Asama-cho, Ise-shi, Mie-ken 516-0021 JAPAN

Telephone : +81 596 24 8999

Facsimile : +81 596 24 8124

Dwell time

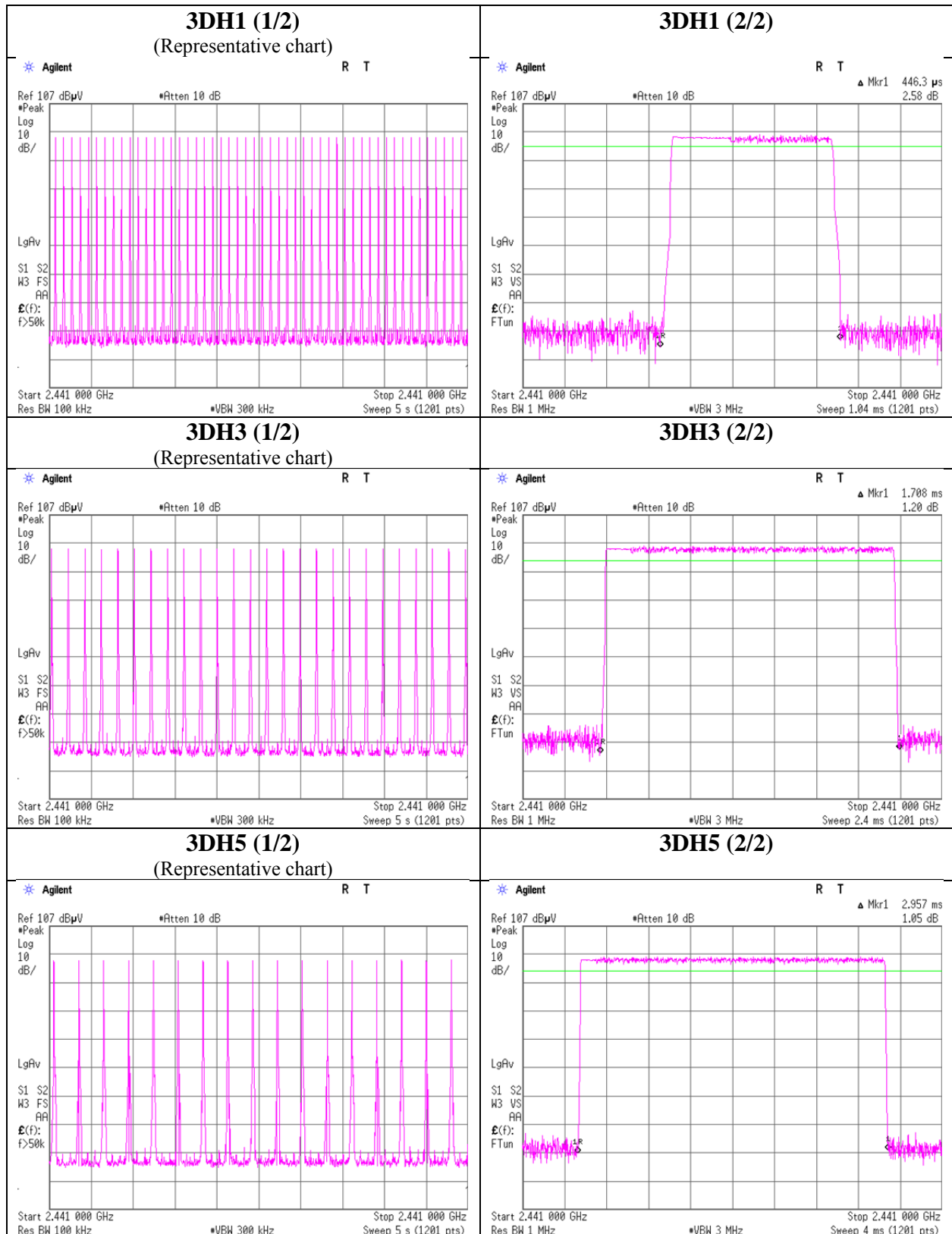

UL Japan, Inc.

Ise EMC Lab.

4383-326 Asama-cho, Ise-shi, Mie-ken 516-0021 JAPAN

Telephone : +81 596 24 8999

Facsimile : +81 596 24 8124

Maximum Peak Output Power

Test place : Ise EMC Lab. No.6 Measurement Room
Report No. : 11394939H
Date : August 3, 2016
Temperature / Humidity : 24 deg. C / 49 % RH
Engineer : Hiroyuki Furutaka
Mode : Tx (Hopping on) DH5/3DH5

Mode	Freq. [MHz]	Reading [dBm]	Cable Loss [dB]	Atten. Loss [dB]	Result		Limit		Margin [dB]
					[dBm]	[mW]	[dBm]	[mW]	
DH5	2402.0	-13.30	2.36	10.08	-0.86	0.82	20.96	125	21.82
DH5	2441.0	-12.67	2.37	10.08	-0.22	0.95	20.96	125	21.18
DH5	2480.0	-13.64	2.38	10.08	-1.18	0.76	20.96	125	22.14
2DH5	2402.0	-11.62	2.36	10.08	0.82	1.21	20.96	125	20.14
2DH5	2441.0	-11.05	2.37	10.08	1.40	1.38	20.96	125	19.56
2DH5	2480.0	-12.07	2.38	10.08	0.39	1.09	20.96	125	20.57
3DH5	2402.0	-11.38	2.36	10.08	1.06	1.28	20.96	125	19.90
3DH5	2441.0	-10.73	2.37	10.08	1.72	1.49	20.96	125	19.24
3DH5	2480.0	-11.81	2.38	10.08	0.65	1.16	20.96	125	20.31

Sample Calculation:

Result = Reading + Cable Loss (including the cable(s) customer supplied) + Attenuator Loss

Test was not performed at AFH mode, because the decrease of number of channel (min: 20ch) at AFH mode does not influence on the output power and bandwidth of the EUT.

①As this device had AFH mode and frequency separation could not meet the requirement of over 20dB BW without 2/3 relaxation, 125mW power limit was applied to it.

Average Output Power
(Reference data for RF Exposure)

Test place : Ise EMC Lab. No.6 Measurement Room
Report No. : 11394939H
Date : August 3, 2016
Temperature / Humidity : 24 deg. C / 49 % RH
Engineer : Hiroyuki Furutaka
Mode : Tx (Hopping on) DH5/3DH5

Mode	Freq. [MHz]	Reading [dBm]	Cable Loss [dB]	Atten. Loss [dB]	Result (Time average)	
					[dBm]	[mW]
DH5	2402.0	-15.44	2.36	10.08	-3.00	0.50
DH5	2441.0	-14.66	2.37	10.08	-2.21	0.60
DH5	2480.0	-15.68	2.38	10.08	-3.22	0.48
2DH5	2402.0	-15.14	2.36	10.08	-2.70	0.54
2DH5	2441.0	-14.44	2.37	10.08	-1.99	0.63
2DH5	2480.0	-15.52	2.38	10.08	-3.06	0.49
3DH5	2402.0	-15.16	2.36	10.08	-2.72	0.53
3DH5	2441.0	-14.45	2.37	10.08	-2.00	0.63
3DH5	2480.0	-15.52	2.38	10.08	-3.06	0.49

Sample Calculation:

Result (Time average) = Reading + Cable Loss (including the cable(s) customer supplied)

Result (Burst power average) = Time average + Duty factor

Burst Rate Confirmation

Test place	Ise EMC Lab. No.6 Measurement Room
Report No.	11394939H
Date	August 3, 2016
Temperature / Humidity	24 deg. C / 49 % RH
Engineer	Hiroyuki Furutaka
Mode	Tx, Hopping Off

DH5

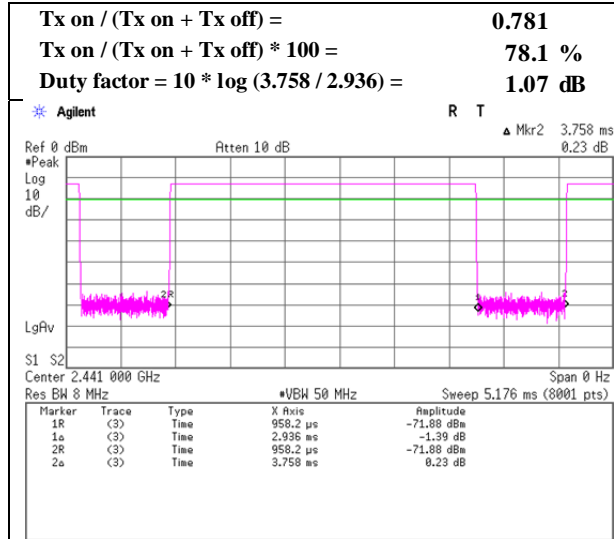

2DH5

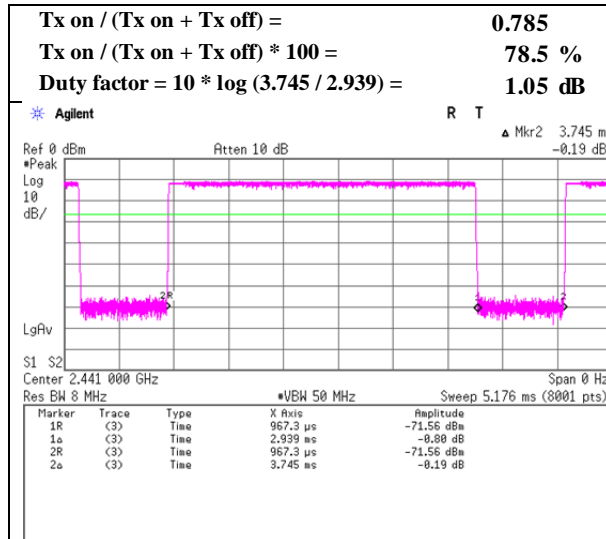

3DH5

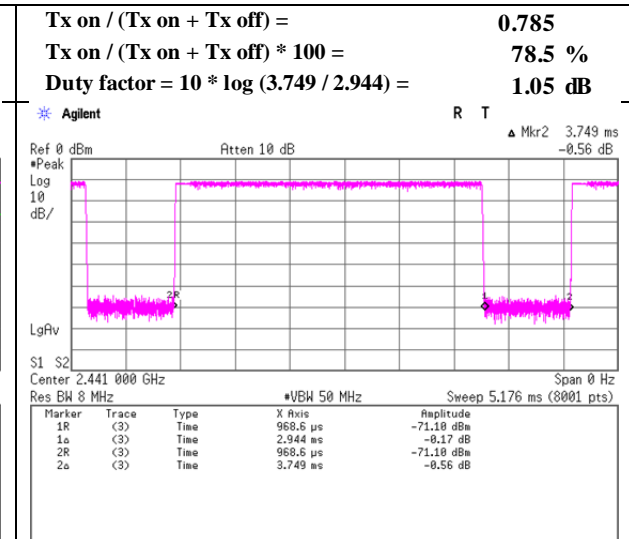

Radiated Spurious Emission

Test place Ise EMC Lab. No.3 Semi Anechoic Chamber
Report No. 11394939H
Date August 22, 2016 August 23, 2016 August 24, 2016
Temperature / Humidity 24 deg. C / 57 % RH 23deg. C / 53% RH 26deg. C / 48% RH
Engineer Shinichi Miyazono Hiroyuki Furutaka Hiroyuki Furutaka
(1 GHz - 10 GHz) (10 GHz - 26.5 GHz) (Below 1 GHz)
Mode Tx, Hopping Off, DH5 2402 MHz

Polarity	Frequency [MHz]	Detector	Reading [dBuV]	Ant.Fac. [dB/m]	Loss [dB]	Gain [dB]	Result [dBuV/m]	Limit [dBuV/m]	Margin [dB]	Remark
Hori	146.244	QP	41.2	14.6	8.6	32.1	32.3	43.5	11.2	
Hori	148.504	QP	43.9	14.7	8.6	32.1	35.1	43.5	8.4	
Hori	445.476	QP	39.2	16.6	10.9	31.9	34.8	46.0	11.2	
Hori	668.176	QP	35.0	19.6	12.3	32.1	34.8	46.0	11.2	
Hori	742.445	QP	36.5	20.2	12.6	31.8	37.5	46.0	8.5	
Hori	884.735	QP	39.7	21.9	13.3	31.0	43.9	46.0	2.1	
Hori	1039.495	PK	60.8	23.7	5.4	35.2	54.7	73.9	19.2	
Hori	1113.713	PK	54.7	24.0	5.5	35.0	49.2	73.9	24.7	
Hori	1484.957	PK	54.0	25.1	5.8	34.0	50.9	73.9	23.0	
Hori	2227.572	PK	50.6	26.5	6.3	32.8	50.6	73.9	23.3	
Hori	2390.000	PK	42.3	26.7	6.4	32.7	42.7	73.9	31.2	
Hori	3523.952	PK	49.3	28.5	7.2	32.2	52.8	73.9	21.1	
Hori	4804.000	PK	41.2	31.0	8.7	31.8	49.1	73.9	24.8	Floor noise
Hori	7206.000	PK	41.6	35.7	9.9	32.6	54.6	73.9	19.3	Floor noise
Hori	9608.000	PK	43.3	37.2	10.6	33.2	57.9	73.9	16.0	Floor noise
Hori	1039.495	AV	57.2	23.7	5.4	35.2	51.1	53.9	2.8	
Hori	1113.713	AV	50.8	24.0	5.5	35.0	45.3	53.9	8.6	
Hori	1484.957	AV	47.7	25.1	5.8	34.0	44.6	53.9	9.3	
Hori	2227.572	AV	43.2	26.5	6.3	32.8	43.2	53.9	10.7	
Hori	2390.000	AV	29.7	26.7	6.4	32.7	30.1	53.9	23.8	
Hori	3523.952	AV	46.3	28.5	7.2	32.2	49.8	53.9	4.1	
Hori	4804.000	AV	28.5	31.0	8.7	31.8	36.4	53.9	17.5	Floor noise
Hori	7206.000	AV	30.2	35.7	9.9	32.6	43.2	53.9	10.7	Floor noise
Hori	9608.000	AV	31.4	37.2	10.6	33.2	46.0	53.9	7.9	Floor noise
Vert	74.244	QP	49.1	6.0	7.7	32.2	30.6	40.0	9.4	
Vert	148.504	QP	43.6	14.7	8.6	32.1	34.8	43.5	8.7	
Vert	445.467	QP	43.1	16.6	10.9	31.9	38.7	46.0	7.3	
Vert	668.213	QP	37.5	19.6	12.3	32.1	37.3	46.0	8.7	
Vert	742.665	QP	33.2	20.2	12.6	31.8	34.2	46.0	11.8	
Vert	884.745	QP	35.3	21.9	13.3	31.0	39.5	46.0	6.5	
Vert	1039.495	PK	54.0	23.7	5.4	35.2	47.9	73.9	26.0	
Vert	1113.713	PK	51.6	24.0	5.5	35.0	46.1	73.9	27.8	
Vert	1484.957	PK	51.2	25.1	5.8	34.0	48.1	73.9	25.8	
Vert	2227.572	PK	47.4	26.5	6.3	32.8	47.4	73.9	26.5	
Vert	2390.000	PK	42.1	26.7	6.4	32.7	42.5	73.9	31.4	
Vert	3523.952	PK	49.4	28.5	7.2	32.2	52.9	73.9	21.0	
Vert	4804.000	PK	40.9	31.0	8.7	31.8	48.8	73.9	25.1	Floor noise
Vert	7206.000	PK	43.0	35.7	9.9	32.6	56.0	73.9	17.9	Floor noise
Vert	9608.000	PK	43.3	37.2	10.6	33.2	57.9	73.9	16.0	Floor noise
Vert	1039.495	AV	49.5	23.7	5.4	35.2	43.4	53.9	10.5	
Vert	1113.713	AV	47.7	24.0	5.5	35.0	42.2	53.9	11.7	
Vert	1484.957	AV	44.5	25.1	5.8	34.0	41.4	53.9	12.5	
Vert	2227.572	AV	39.9	26.5	6.3	32.8	39.9	53.9	14.0	
Vert	2390.000	AV	30.3	26.7	6.4	32.7	30.7	53.9	23.2	
Vert	3523.952	AV	46.4	28.5	7.2	32.2	49.9	53.9	4.0	
Vert	4804.000	AV	29.1	31.0	8.7	31.8	37.0	53.9	16.9	Floor noise
Vert	7206.000	AV	30.5	35.7	9.9	32.6	43.5	53.9	10.4	Floor noise
Vert	9608.000	AV	31.2	37.2	10.6	33.2	45.8	53.9	8.1	Floor noise

Result = Reading + Ant Factor + Loss (Cable+Attenuator+Filter+Distance factor(above 1 GHz)) - Gain(Amplifier)

*Other frequency noise omitted in this report were not seen or had enough margin (more than 20 dB).

Distance factor: 1 GHz - 10 GHz 20log(4.3 m / 3.0 m) = 3.13 dB
10 GHz - 26.5 GHz 20log(1.0 m / 3.0 m) = -9.5 dB

*These results have sufficient margin without taking account Dwell time factor.

UL Japan, Inc.

Ise EMC Lab.

4383-326 Asama-cho, Ise-shi, Mie-ken 516-0021 JAPAN

Telephone : +81 596 24 8999

Facsimile : +81 596 24 8124

Radiated Spurious Emission

Test place : Ise EMC Lab. No.3 Semi Anechoic Chamber
 Report No. : 11394939H
 Date : August 22, 2016
 Temperature / Humidity : 24 deg. C / 57 % RH
 Engineer : Shinichi Miyazono
 (1 GHz - 10 GHz)
 Mode : Tx, Hopping Off, DH5 2402 MHz

20dBc Data Sheet

Polarity	Frequency [MHz]	Detector	Reading [dBuV]	Ant Factor [dB/m]	Loss [dB]	Gain [dB]	Result [dBuV/m]	Limit [dBuV/m]	Margin [dB]	Remark
Hori	2402.000	PK	94.4	26.7	6.4	32.7	94.8	-	-	Carrier
Hori	2400.000	PK	43.8	26.7	6.4	32.7	44.2	74.8	30.6	
Vert	2402.000	PK	87.7	26.7	6.4	32.7	88.1	-	-	Carrier
Vert	2400.000	PK	39.8	26.7	6.4	32.7	40.2	68.1	27.9	

Result = Reading + Ant Factor + Loss (Cable+Attenuator+Filter+Distance factor(above 1 GHz)) - Gain(Amplifier)

UL Japan, Inc.

Ise EMC Lab.

4383-326 Asama-cho, Ise-shi, Mie-ken 516-0021 JAPAN

Telephone : +81 596 24 8999

Facsimile : +81 596 24 8124

Radiated Spurious Emission
(Reference Plot for band-edge)

Test place	Ise EMC Lab. No.3 Semi Anechoic Chamber
Report No.	11394939H
Date	August 22, 2016
Temperature / Humidity	24 deg. C / 57 % RH
Engineer	Shinichi Miyazono
Mode	Tx, Hopping Off, DH5 2402 MHz

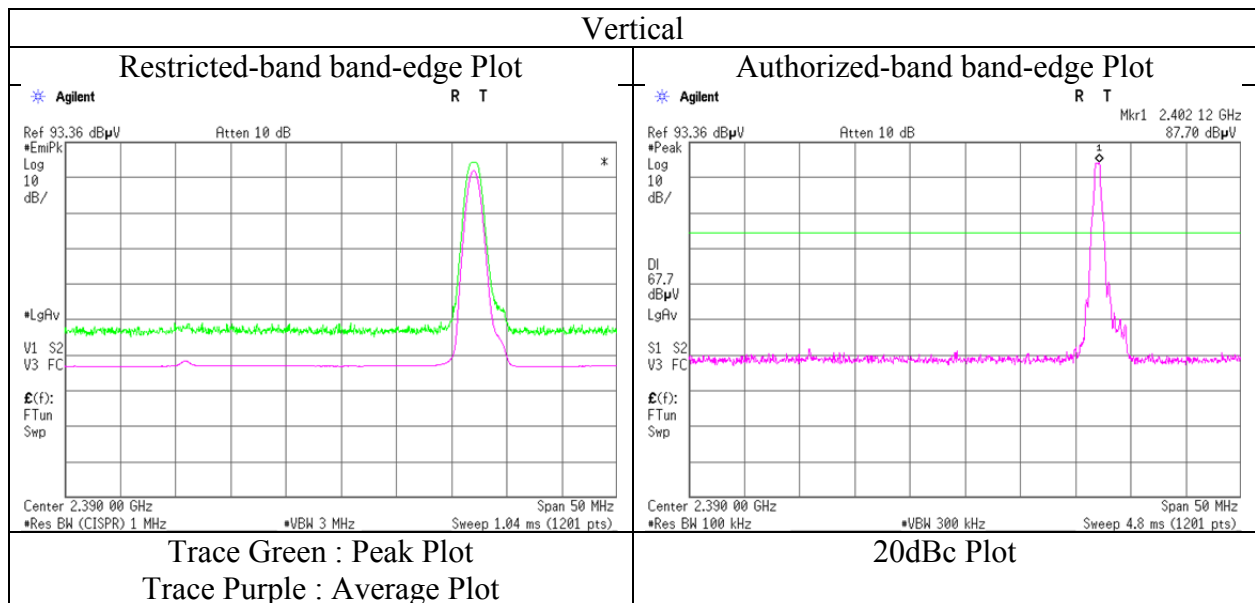
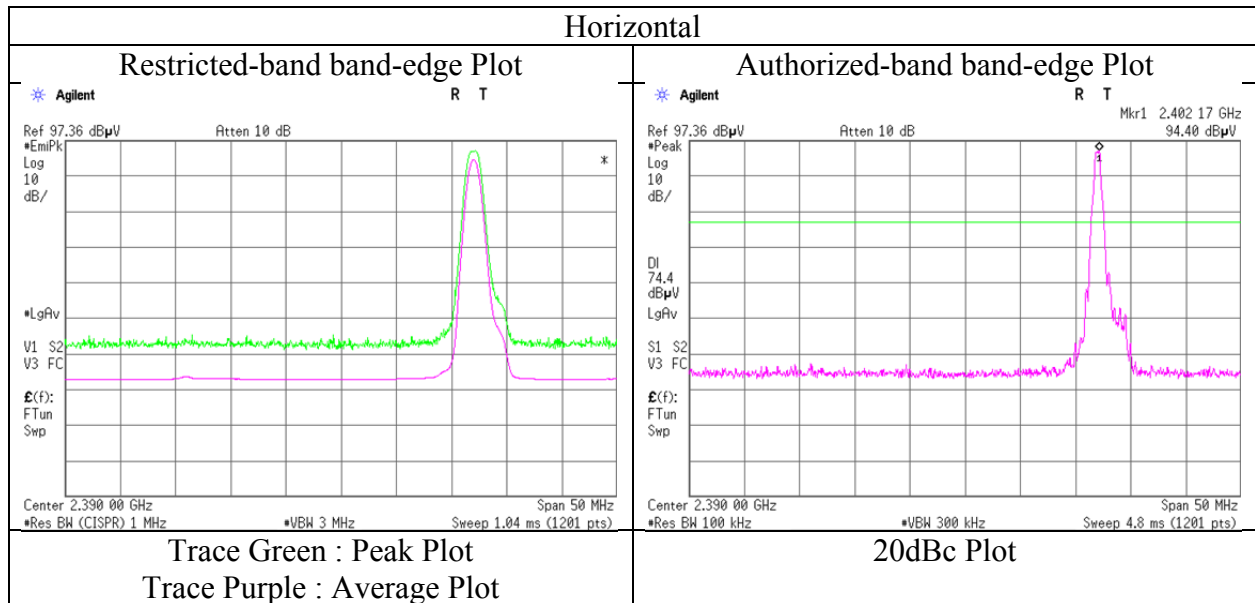

* Final result of restricted band edge was shown in tabular data.

Radiated Spurious Emission

Test place Ise EMC Lab. No.3 Semi Anechoic Chamber
Report No. 11394939H
Date August 22, 2016 August 23, 2016 August 24, 2016
Temperature / Humidity 24 deg. C / 57 % RH 23deg. C / 53% RH 26deg. C / 48% RH
Engineer Shinichi Miyazono Hiroyuki Furutaka Hiroyuki Furutaka
(1 GHz - 10 GHz) (10 GHz - 26.5 GHz) (Below 1 GHz)
Mode Tx, Hopping Off, DH5 2441MHz

Polarity	Frequency [MHz]	Detector	Reading [dBuV]	Ant.Fac. [dB/m]	Loss [dB]	Gain [dB]	Result [dBuV/m]	Limit [dBuV/m]	Margin [dB]	Remark
Hori	146.245	QP	41.3	14.6	8.6	32.1	32.4	43.5	11.1	
Hori	148.509	QP	44.0	14.7	8.6	32.1	35.2	43.5	8.3	
Hori	445.487	QP	39.3	16.6	10.9	31.9	34.9	46.0	11.1	
Hori	668.172	QP	34.9	19.6	12.3	32.1	34.7	46.0	11.3	
Hori	742.441	QP	36.4	20.2	12.6	31.8	37.4	46.0	8.6	
Hori	884.734	QP	39.4	21.9	13.3	31.0	43.6	46.0	2.4	
Hori	1039.597	PK	60.7	23.7	5.4	35.2	54.6	73.9	19.3	
Hori	1113.728	PK	59.8	24.0	5.5	35.0	54.3	73.9	19.6	
Hori	1484.999	PK	54.7	25.1	5.8	34.0	51.6	73.9	22.3	
Hori	2227.444	PK	50.0	26.5	6.3	32.8	50.0	73.9	23.9	
Hori	3523.817	PK	45.9	28.5	7.2	32.2	49.4	73.9	24.5	
Hori	4882.000	PK	39.9	31.3	8.7	31.7	48.2	73.9	25.7	Floor noise
Hori	7323.000	PK	41.7	35.6	9.9	32.6	54.6	73.9	19.3	Floor noise
Hori	9764.000	PK	41.8	37.2	10.6	33.3	56.3	73.9	17.6	Floor noise
Hori	1039.597	AV	57.1	23.7	5.4	35.2	51.0	53.9	2.9	
Hori	1113.728	AV	56.6	24.0	5.5	35.0	51.1	53.9	2.8	
Hori	1484.999	AV	48.8	25.1	5.8	34.0	45.7	53.9	8.2	
Hori	2227.444	AV	43.6	26.5	6.3	32.8	43.6	53.9	10.3	
Hori	3523.817	AV	41.4	28.5	7.2	32.2	44.9	53.9	9.0	
Hori	4882.000	AV	28.6	31.3	8.7	31.7	36.9	53.9	17.0	Floor noise
Hori	7323.000	AV	30.1	35.6	9.9	32.6	43.0	53.9	10.9	Floor noise
Hori	9764.000	AV	30.1	37.2	10.6	33.3	44.6	53.9	9.3	Floor noise
Vert	74.250	QP	49.3	6.0	7.7	32.2	30.8	40.0	9.2	
Vert	148.509	QP	43.6	14.7	8.6	32.1	34.8	43.5	8.7	
Vert	445.461	QP	43.2	16.6	10.9	31.9	38.8	46.0	7.2	
Vert	668.223	QP	37.2	19.6	12.3	32.1	37.0	46.0	9.0	
Vert	742.645	QP	33.0	20.2	12.6	31.8	34.0	46.0	12.0	
Vert	884.743	QP	35.2	21.9	13.3	31.0	39.4	46.0	6.6	
Vert	1039.597	PK	55.1	23.7	5.4	35.2	49.0	73.9	24.9	
Vert	1113.728	PK	51.5	24.0	5.5	35.0	46.0	73.9	27.9	
Vert	1484.999	PK	51.2	25.1	5.8	34.0	48.1	73.9	25.8	
Vert	2227.444	PK	49.4	26.5	6.3	32.8	49.4	73.9	24.5	
Vert	3523.817	PK	47.9	28.5	7.2	32.2	51.4	73.9	22.5	
Vert	4882.000	PK	40.9	31.3	8.7	31.7	49.2	73.9	24.7	Floor noise
Vert	7323.000	PK	41.4	35.6	9.9	32.6	54.3	73.9	19.6	Floor noise
Vert	9764.000	PK	41.5	37.2	10.6	33.3	56.0	73.9	17.9	Floor noise
Vert	1039.597	AV	50.4	23.7	5.4	35.2	44.3	53.9	9.6	
Vert	1113.728	AV	47.6	24.0	5.5	35.0	42.1	53.9	11.8	
Vert	1484.999	AV	44.6	25.1	5.8	34.0	41.5	53.9	12.4	
Vert	2227.444	AV	43.2	26.5	6.3	32.8	43.2	53.9	10.7	
Vert	3523.817	AV	44.3	28.5	7.2	32.2	47.8	53.9	6.1	
Vert	4882.000	AV	28.6	31.3	8.7	31.7	36.9	53.9	17.0	Floor noise
Vert	7323.000	AV	30.1	35.6	9.9	32.6	43.0	53.9	10.9	Floor noise
Vert	9764.000	AV	30.1	37.2	10.6	33.3	44.6	53.9	9.3	Floor noise

Result = Reading + Ant Factor + Loss (Cable+Attenuator+Filter+Distance factor(above 1 GHz)) - Gain(Amplifier)

*Other frequency noises omitted in this report were not seen or had enough margin (more than 20 dB).

Distance factor: 1 GHz - 10 GHz 20log(4.3 m / 3.0 m) = 3.13 dB
10 GHz - 26.5 GHz 20log(1.0 m / 3.0 m) = -9.5 dB

***These results have sufficient margin without taking account Dwell time factor.**

UL Japan, Inc.

Ise EMC Lab.

4383-326 Asama-cho, Ise-shi, Mie-ken 516-0021 JAPAN

Telephone : +81 596 24 8999

Facsimile : +81 596 24 8124

Radiated Spurious Emission

Test place Ise EMC Lab. No.3 Semi Anechoic Chamber
Report No. 11394939H
Date August 22, 2016 August 23, 2016 August 24, 2016
Temperature / Humidity 24 deg. C / 57 % RH 23deg. C / 53% RH 26deg. C / 48% RH
Engineer Shinichi Miyazono Hiroyuki Furutaka Hiroyuki Furutaka
(1 GHz - 10 GHz) (10 GHz - 26.5 GHz) (Below 1 GHz)
Mode Tx, Hopping Off, DH5 2480 MHz

Polarity	Frequency [MHz]	Detector	Reading [dBuV]	Ant.Fac. [dB/m]	Loss [dB]	Gain [dB]	Result [dBuV/m]	Limit [dBuV/m]	Margin [dB]	Remark
Hori	146.251	QP	41.5	14.6	8.6	32.1	32.6	43.5	10.9	
Hori	148.510	QP	44.2	14.7	8.6	32.1	35.4	43.5	8.1	
Hori	445.484	QP	39.5	16.6	10.9	31.9	35.1	46.0	10.9	
Hori	668.180	QP	35.0	19.6	12.3	32.1	34.8	46.0	11.2	
Hori	742.445	QP	36.5	20.2	12.6	31.8	37.5	46.0	8.5	
Hori	884.731	QP	39.3	21.9	13.3	31.0	43.5	46.0	2.5	
Hori	1039.604	PK	60.3	23.7	5.4	35.2	54.2	73.9	19.7	
Hori	1113.708	PK	56.3	24.0	5.5	35.0	50.8	73.9	23.1	
Hori	1484.957	PK	54.9	25.1	5.8	34.0	51.8	73.9	22.1	
Hori	2227.384	PK	47.8	26.5	6.3	32.8	47.8	73.9	26.1	
Hori	2483.500	PK	42.7	26.8	6.5	32.6	43.4	73.9	30.5	
Hori	3523.987	PK	48.8	28.5	7.2	32.2	52.3	73.9	21.6	
Hori	4960.000	PK	41.2	31.5	8.6	31.7	49.6	73.9	24.3	Floor noise
Hori	7440.000	PK	42.1	35.5	9.9	32.7	54.8	73.9	19.1	Floor noise
Hori	9920.000	PK	41.7	37.2	10.7	33.4	56.2	73.9	17.7	Floor noise
Hori	1039.604	AV	57.3	23.7	5.4	35.2	51.2	53.9	2.7	
Hori	1113.708	AV	51.3	24.0	5.5	35.0	45.8	53.9	8.1	
Hori	1484.957	AV	48.7	25.1	5.8	34.0	45.6	53.9	8.3	
Hori	2227.384	AV	41.3	26.5	6.3	32.8	41.3	53.9	12.6	
Hori	2483.500	AV	28.7	26.8	6.5	32.6	29.4	53.9	24.5	
Hori	3523.987	AV	46.0	28.5	7.2	32.2	49.5	53.9	4.4	
Hori	4960.000	AV	28.6	31.5	8.6	31.7	37.0	53.9	16.9	Floor noise
Hori	7440.000	AV	30.0	35.5	9.9	32.7	42.7	53.9	11.2	Floor noise
Hori	9920.000	AV	30.0	37.2	10.7	33.4	44.5	53.9	9.4	Floor noise
Vert	74.251	QP	49.5	6.0	7.7	32.2	31.0	40.0	9.0	
Vert	148.510	QP	43.9	14.7	8.6	32.1	35.1	43.5	8.4	
Vert	445.465	QP	43.4	16.6	10.9	31.9	39.0	46.0	7.0	
Vert	668.230	QP	37.0	19.6	12.3	32.1	36.8	46.0	9.2	
Vert	742.648	QP	33.1	20.2	12.6	31.8	34.1	46.0	11.9	
Vert	884.745	QP	35.4	21.9	13.3	31.0	39.6	46.0	6.4	
Vert	1039.604	PK	54.5	23.7	5.4	35.2	48.4	73.9	25.5	
Vert	1113.708	PK	52.2	24.0	5.5	35.0	46.7	73.9	27.2	
Vert	1484.957	PK	48.4	25.1	5.8	34.0	45.3	73.9	28.6	
Vert	2227.384	PK	49.6	26.5	6.3	32.8	49.6	73.9	24.3	
Vert	2483.500	PK	42.4	26.8	6.5	32.6	43.1	73.9	30.8	
Vert	3523.987	PK	46.9	28.5	7.2	32.2	50.4	73.9	23.5	
Vert	4960.000	PK	40.5	31.5	8.6	31.7	48.9	73.9	25.0	Floor noise
Vert	7440.000	PK	43.1	35.5	9.9	32.7	55.8	73.9	18.1	Floor noise
Vert	9920.000	PK	41.8	37.2	10.7	33.4	56.3	73.9	17.6	Floor noise
Vert	1039.604	AV	50.0	23.7	5.4	35.2	43.9	53.9	10.0	
Vert	1113.708	AV	48.0	24.0	5.5	35.0	42.5	53.9	11.4	
Vert	1484.957	AV	45.0	25.1	5.8	34.0	41.9	53.9	12.0	
Vert	2227.384	AV	43.2	26.5	6.3	32.8	43.2	53.9	10.7	
Vert	2483.500	AV	29.0	26.8	6.5	32.6	29.7	53.9	24.2	
Vert	3523.987	AV	42.6	28.5	7.2	32.2	46.1	53.9	7.8	
Vert	4960.000	AV	28.6	31.5	8.6	31.7	37.0	53.9	16.9	Floor noise
Vert	7440.000	AV	30.0	35.5	9.9	32.7	42.7	53.9	11.2	Floor noise
Vert	9920.000	AV	30.0	37.2	10.7	33.4	44.5	53.9	9.4	Floor noise

Result = Reading + Ant Factor + Loss (Cable+Attenuator+Filter+Distance factor(above 1 GHz)) - Gain(Amplifier)

*Other frequency noises omitted in this report were not seen or had enough margin (more than 20 dB).

Distance factor: 1 GHz - 10 GHz 20log(4.3 m / 3.0 m) = 3.13 dB
10 GHz - 26.5 GHz 20log(1.0 m / 3.0 m) = -9.5 dB

***These results have sufficient margin without taking account Dwell time factor.**

UL Japan, Inc.

Ise EMC Lab.

4383-326 Asama-cho, Ise-shi, Mie-ken 516-0021 JAPAN

Telephone : +81 596 24 8999

Facsimile : +81 596 24 8124

Radiated Spurious Emission
(Reference Plot for band-edge)

Test place Ise EMC Lab. No.3 Semi Anechoic Chamber
Report No. 11394939H
Date August 22, 2016
Temperature / Humidity 24 deg. C / 57 % RH
Engineer Shinichi Miyazono
Mode Tx, Hopping Off, DH5 2480 MHz

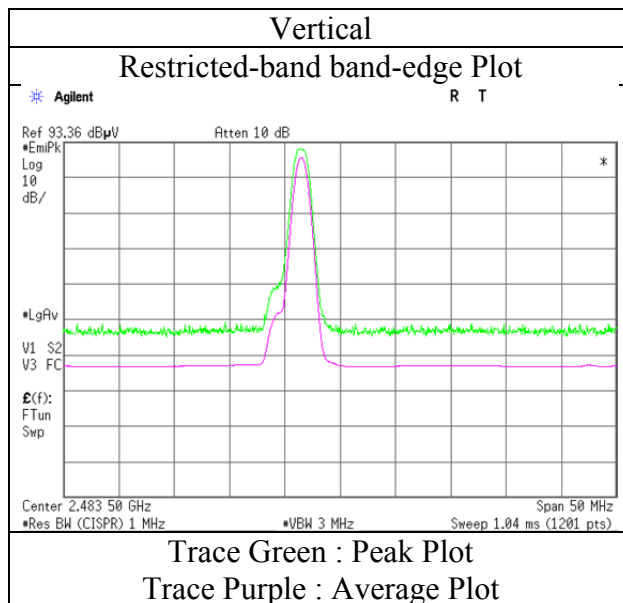
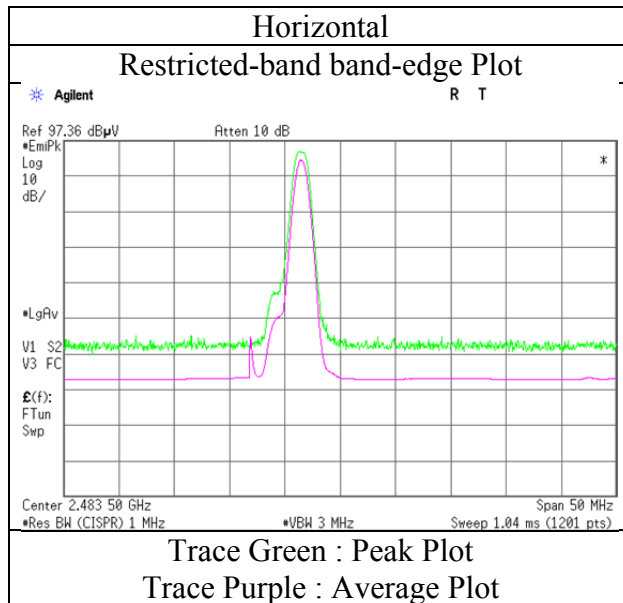

* Final result of restricted band edge was shown in tabular data.

Radiated Spurious Emission

Test place Ise EMC Lab. No.3 Semi Anechoic Chamber
Report No. 11394939H
Date August 22, 2016 August 23, 2016 August 24, 2016
Temperature / Humidity 23 deg. C / 56 % RH 23deg. C / 53% RH 26deg. C / 48% RH
Engineer Hiroyuki Furutaka Hiroyuki Furutaka Hiroyuki Furutaka
(1 GHz - 10 GHz) (10 GHz - 26.5 GHz) (Below 1 GHz)
Mode Tx, Hopping Off, 3DH5 2402 MHz

Polarity	Frequency [MHz]	Detector	Reading [dBuV]	Ant.Fac. [dB/m]	Loss [dB]	Gain [dB]	Result [dBuV/m]	Limit [dBuV/m]	Margin [dB]	Remark
Hori	146.251	QP	41.1	14.6	8.6	32.1	32.2	43.5	11.3	
Hori	148.494	QP	43.6	14.7	8.6	32.1	34.8	43.5	8.7	
Hori	445.484	QP	39.5	16.6	10.9	31.9	35.1	46.0	10.9	
Hori	668.221	QP	38.4	19.6	12.3	32.1	38.2	46.0	7.8	
Hori	742.465	QP	38.4	20.2	12.6	31.8	39.4	46.0	6.6	
Hori	884.731	QP	39.7	21.9	13.3	31.0	43.9	46.0	2.1	
Hori	1039.496	PK	58.9	23.7	5.4	35.2	52.8	73.9	21.1	
Hori	1113.713	PK	55.1	24.0	5.5	35.0	49.6	73.9	24.3	
Hori	1484.955	PK	54.7	25.1	5.8	34.0	51.6	73.9	22.3	
Hori	2227.439	PK	50.7	26.5	6.3	32.8	50.7	73.9	23.2	
Hori	2375.975	PK	43.8	26.7	6.4	32.7	44.2	73.9	29.7	
Hori	2390.000	PK	41.5	26.7	6.4	32.7	41.9	73.9	32.0	
Hori	3523.952	PK	49.0	28.5	7.2	32.2	52.5	73.9	21.4	
Hori	4804.000	PK	40.4	31.0	8.7	31.8	48.3	73.9	25.6	Floor noise
Hori	7206.000	PK	42.8	35.7	9.9	32.6	55.8	73.9	18.1	Floor noise
Hori	8196.980	PK	43.0	36.2	10.0	32.8	56.4	73.9	17.5	
Hori	9608.000	PK	43.6	37.2	10.6	33.2	58.2	73.9	15.7	Floor noise
Hori	1039.496	AV	56.5	23.7	5.4	35.2	50.4	53.9	3.5	
Hori	1113.713	AV	50.5	24.0	5.5	35.0	45.0	53.9	8.9	
Hori	1484.955	AV	48.7	25.1	5.8	34.0	45.6	53.9	8.3	
Hori	2227.439	AV	43.2	26.5	6.3	32.8	43.2	53.9	10.7	
Hori	2375.975	AV	32.9	26.7	6.4	32.7	33.3	53.9	20.6	
Hori	2390.000	AV	29.8	26.7	6.4	32.7	30.2	53.9	23.7	
Hori	3523.952	AV	46.0	28.5	7.2	32.2	49.5	53.9	4.4	
Hori	4804.000	AV	28.8	31.0	8.7	31.8	36.7	53.9	17.2	Floor noise
Hori	7206.000	AV	30.4	35.7	9.9	32.6	43.4	53.9	10.5	Floor noise
Hori	8196.980	AV	33.8	36.2	10.0	32.8	47.2	53.9	6.7	
Hori	9608.000	AV	31.2	37.2	10.6	33.2	45.8	53.9	8.1	Floor noise
Vert	74.251	QP	49.1	6.0	7.7	32.2	30.6	40.0	9.4	
Vert	148.494	QP	44.7	14.7	8.6	32.1	35.9	43.5	7.6	
Vert	445.483	QP	43.2	16.6	10.9	31.9	38.8	46.0	7.2	
Vert	668.223	QP	37.8	19.6	12.3	32.1	37.6	46.0	8.4	
Vert	742.476	QP	33.4	20.2	12.6	31.8	34.4	46.0	11.6	
Vert	884.741	QP	36.6	21.9	13.3	31.0	40.8	46.0	5.2	
Vert	1039.496	PK	57.9	23.7	5.4	35.2	51.8	73.9	22.1	
Vert	1113.713	PK	52.1	24.0	5.5	35.0	46.6	73.9	27.3	
Vert	1484.955	PK	52.0	25.1	5.8	34.0	48.9	73.9	25.0	
Vert	2227.439	PK	48.6	26.5	6.3	32.8	48.6	73.9	25.3	
Vert	2375.975	PK	44.1	26.7	6.4	32.7	44.5	73.9	29.4	
Vert	2390.000	PK	41.8	26.7	6.4	32.7	42.2	73.9	31.7	
Vert	3523.952	PK	49.6	28.5	7.2	32.2	53.1	73.9	20.8	
Vert	4804.000	PK	40.7	31.0	8.7	31.8	48.6	73.9	25.3	Floor noise
Vert	7206.000	PK	42.3	35.7	9.9	32.6	55.3	73.9	18.6	Floor noise
Vert	8196.960	PK	44.0	36.2	10.0	32.8	57.4	73.9	16.5	
Vert	9608.000	PK	43.4	37.2	10.6	33.2	58.0	73.9	15.9	Floor noise

Result = Reading + Ant Factor + Loss (Cable+Attenuator+Filter+Distance factor(above 1 GHz)) - Gain(Amplifier)

*Other frequency noises omitted in this report were not seen or had enough margin (more than 20 dB).

Distance factor: 1 GHz - 10 GHz 20log(4.3 m / 3.0 m) = 3.13 dB
10 GHz - 26.5 GHz 20log(1.0 m / 3.0 m) = -9.5 dB

***These results have sufficient margin without taking account Dwell time factor.**

UL Japan, Inc.

Ise EMC Lab.

4383-326 Asama-cho, Ise-shi, Mie-ken 516-0021 JAPAN

Telephone : +81 596 24 8999

Facsimile : +81 596 24 8124

Radiated Spurious Emission

Test place	Ise EMC Lab. No.3 Semi Anechoic Chamber		
Report No.	11394939H		
Date	August 22, 2016	August 23, 2016	August 24, 2016
Temperature / Humidity	23 deg. C / 56 % RH	23deg. C / 53% RH	26deg. C / 48% RH
Engineer	Hiroyuki Furutaka	Hiroyuki Furutaka	Hiroyuki Furutaka
	(1 GHz - 10 GHz)	(10 GHz - 26.5 GHz)	(Below 1 GHz)
Mode	Tx, Hopping Off, 3DH5 2402 MHz		

20dBc Data Sheet

Polarity	Frequency	Detector	Reading	Ant Factor	Loss	Gain	Result	Limit	Margin	Remark
	[MHz]		[dBuV]	[dB/m]	[dB]	[dB]	[dBuV/m]	[dBuV/m]	[dB]	
Hori	2402.000	PK	96.2	26.7	6.4	32.7	96.6	-	-	Carrier
Hori	2400.000	PK	56.3	26.7	6.4	32.7	56.7	76.6	19.9	
Vert	2402.000	PK	96.0	26.7	6.4	32.7	96.4	-	-	Carrier
Vert	2400.000	PK	56.3	26.7	6.4	32.7	56.7	76.4	19.7	

Result = Reading + Ant Factor + Loss (Cable+Attenuator+Filter+Distance factor(above 1 GHz)) - Gain(Amplifier)

UL Japan, Inc.

Ise EMC Lab.

4383-326 Asama-cho, Ise-shi, Mie-ken 516-0021 JAPAN

Telephone : +81 596 24 8999

Facsimile : +81 596 24 8124

Radiated Spurious Emission
(Reference Plot for band-edge)

Test place	Ise EMC Lab. No.3 Semi Anechoic Chamber
Report No.	11394939H
Date	August 22, 2016
Temperature / Humidity	23 deg. C / 56 % RH
Engineer	Hiroyuki Furutaka
Mode	Tx, Hopping Off, 3DH5 2402 MHz

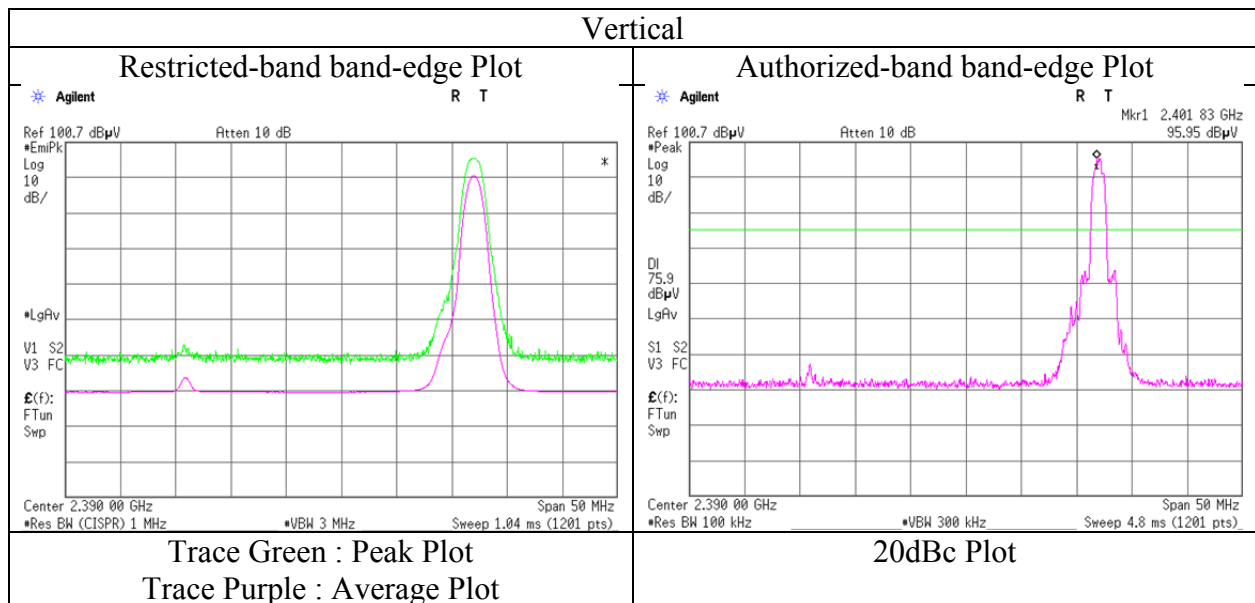
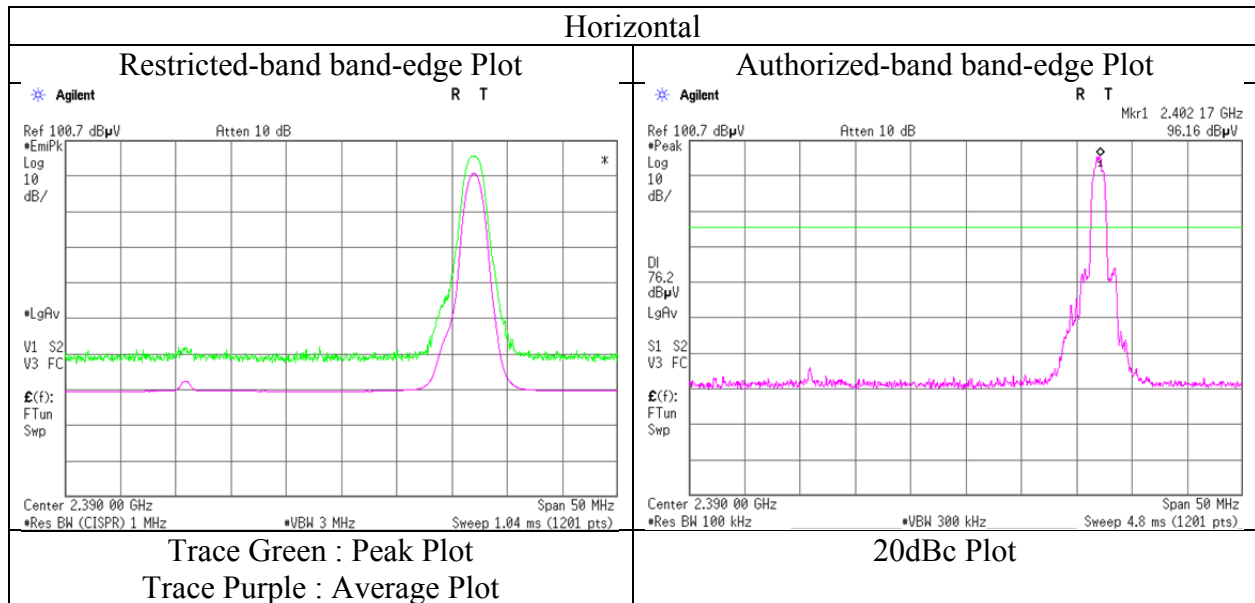

* Final result of restricted band edge was shown in tabular data.

Radiated Spurious Emission

Test place Ise EMC Lab. No.3 Semi Anechoic Chamber
Report No. 11394939H
Date August 22, 2016 August 23, 2016 August 24, 2016
Temperature / Humidity 23 deg. C / 56 % RH 23deg. C / 53% RH 26deg. C / 48% RH
Engineer Hiroyuki Furutaka Hiroyuki Furutaka Hiroyuki Furutaka
(1 GHz - 10 GHz) (10 GHz - 26.5 GHz) (Below 1 GHz)
Mode Tx, Hopping Off, 3DH5 2441 MHz

Polarity	Frequency [MHz]	Detector	Reading [dBuV]	Ant.Fac. [dB/m]	Loss [dB]	Gain [dB]	Result [dBuV/m]	Limit [dBuV/m]	Margin [dB]	Remark
Hori	146.253	QP	41.3	14.6	8.6	32.1	32.4	43.5	11.1	
Hori	148.495	QP	43.7	14.7	8.6	32.1	34.9	43.5	8.6	
Hori	445.482	QP	39.4	16.6	10.9	31.9	35.0	46.0	11.0	
Hori	668.220	QP	38.4	19.6	12.3	32.1	38.2	46.0	7.8	
Hori	742.461	QP	38.6	20.2	12.6	31.8	39.6	46.0	6.4	
Hori	884.738	QP	39.8	21.9	13.3	31.0	44.0	46.0	2.0	
Hori	1039.496	PK	59.0	23.7	5.4	35.2	52.9	73.9	21.0	
Hori	1113.716	PK	54.7	24.0	5.5	35.0	49.2	73.9	24.7	
Hori	1484.955	PK	54.3	25.1	5.8	34.0	51.2	73.9	22.7	
Hori	2227.443	PK	50.5	26.5	6.3	32.8	50.5	73.9	23.4	
Hori	3523.960	PK	48.8	28.5	7.2	32.2	52.3	73.9	21.6	
Hori	4882.000	PK	40.2	31.3	8.7	31.7	48.5	73.9	25.4	Floor noise
Hori	7323.000	PK	42.5	35.6	9.9	32.6	55.4	73.9	18.5	Floor noise
Hori	8200.000	PK	43.4	36.2	10.0	32.8	56.8	73.9	17.1	
Hori	9764.000	PK	43.4	37.2	10.6	33.3	57.9	73.9	16.0	Floor noise
Hori	1039.496	AV	56.8	23.7	5.4	35.2	50.7	53.9	3.2	
Hori	1113.716	AV	50.3	24.0	5.5	35.0	44.8	53.9	9.1	
Hori	1484.955	AV	48.5	25.1	5.8	34.0	45.4	53.9	8.5	
Hori	2227.443	AV	43.0	26.5	6.3	32.8	43.0	53.9	10.9	
Hori	3523.960	AV	45.7	28.5	7.2	32.2	49.2	53.9	4.7	
Hori	4882.000	AV	28.7	31.3	8.7	31.7	37.0	53.9	16.9	Floor noise
Hori	7323.000	AV	30.3	35.6	9.9	32.6	43.2	53.9	10.7	Floor noise
Hori	8200.000	AV	33.2	36.2	10.0	32.8	46.6	53.9	7.3	
Hori	9764.000	AV	31.0	37.2	10.6	33.3	45.5	53.9	8.4	Floor noise
Vert	74.250	QP	49.2	6.0	7.7	32.2	30.7	40.0	9.3	
Vert	148.494	QP	44.9	14.7	8.6	32.1	36.1	43.5	7.4	
Vert	445.481	QP	43.0	16.6	10.9	31.9	38.6	46.0	7.4	
Vert	668.222	QP	37.7	19.6	12.3	32.1	37.5	46.0	8.5	
Vert	742.472	QP	33.5	20.2	12.6	31.8	34.5	46.0	11.5	
Vert	884.739	QP	36.6	21.9	13.3	31.0	40.8	46.0	5.2	
Vert	1039.497	PK	58.0	23.7	5.4	35.2	51.9	73.9	22.0	
Vert	1113.713	PK	51.8	24.0	5.5	35.0	46.3	73.9	27.6	
Vert	1484.952	PK	51.8	25.1	5.8	34.0	48.7	73.9	25.2	
Vert	2227.441	PK	48.5	26.5	6.3	32.8	48.5	73.9	25.4	
Vert	3523.952	PK	49.4	28.5	7.2	32.2	52.9	73.9	21.0	
Vert	4882.000	PK	41.3	31.3	8.7	31.7	49.6	73.9	24.3	Floor noise
Vert	7323.000	PK	42.1	35.6	9.9	32.6	55.0	73.9	18.9	Floor noise
Vert	8200.000	PK	42.8	36.2	10.0	32.8	56.2	73.9	17.7	
Vert	9764.000	PK	43.1	37.2	10.6	33.3	57.6	73.9	16.3	Floor noise
Vert	1039.496	AV	53.4	23.7	5.4	35.2	47.3	53.9	6.6	
Vert	1113.713	AV	47.6	24.0	5.5	35.0	42.1	53.9	11.8	
Vert	1484.952	AV	44.3	25.1	5.8	34.0	41.2	53.9	12.7	
Vert	2227.441	AV	41.7	26.5	6.3	32.8	41.7	53.9	12.2	
Vert	3523.952	AV	44.8	28.5	7.2	32.2	48.3	53.9	5.6	
Vert	4882.000	AV	29.3	31.3	8.7	31.7	37.6	53.9	16.3	Floor noise
Vert	7323.000	AV	30.2	35.6	9.9	32.6	43.1	53.9	10.8	Floor noise
Vert	8200.000	AV	34.9	36.2	10.0	32.8	48.3	53.9	5.6	
Vert	9764.000	AV	30.8	37.2	10.6	33.3	45.3	53.9	8.6	Floor noise

Result = Reading + Ant Factor + Loss (Cable+Attenuator+Filter+Distance factor(above 1 GHz)) - Gain(Amplifier)

*Other frequency noises omitted in this report were not seen or had enough margin (more than 20 dB).

Distance factor: 1 GHz - 10 GHz 20log(4.3 m / 3.0 m) = 3.13 dB
10 GHz - 26.5 GHz 20log(1.0 m / 3.0 m) = -9.5 dB

***These results have sufficient margin without taking account Dwell time factor.**

UL Japan, Inc.

Ise EMC Lab.

4383-326 Asama-cho, Ise-shi, Mie-ken 516-0021 JAPAN

Telephone : +81 596 24 8999

Facsimile : +81 596 24 8124

Radiated Spurious Emission

Test place : Ise EMC Lab. No.3 Semi Anechoic Chamber
Report No. : 11394939H
Date : August 22, 2016 August 23, 2016 August 24, 2016
Temperature / Humidity : 23 deg. C / 56 % RH 23deg. C / 53% RH 26deg. C / 48% RH
Engineer : Hiroyuki Furutaka Hiroyuki Furutaka Hiroyuki Furutaka
 (1 GHz - 10 GHz) (10 GHz - 26.5 GHz) (Below 1 GHz)
Mode : Tx, Hopping Off, 3DH5 2480 MHz

Polarity	Frequency [MHz]	Detector	Reading [dBuV]	Ant.Fac. [dB/m]	Loss [dB]	Gain [dB]	Result [dBuV/m]	Limit [dBuV/m]	Margin [dB]	Remark
Hori	146.253	QP	41.2	14.6	8.6	32.1	32.3	43.5	11.2	
Hori	148.495	QP	44.0	14.7	8.6	32.1	35.2	43.5	8.3	
Hori	445.480	QP	39.5	16.6	10.9	31.9	35.1	46.0	10.9	
Hori	668.223	QP	38.6	19.6	12.3	32.1	38.4	46.0	7.6	
Hori	742.459	QP	38.7	20.2	12.6	31.8	39.7	46.0	6.3	
Hori	884.740	QP	39.6	21.9	13.3	31.0	43.8	46.0	2.2	
Hori	1039.500	PK	58.9	23.7	5.4	35.2	52.8	73.9	21.1	
Hori	1113.720	PK	54.9	24.0	5.5	35.0	49.4	73.9	24.5	
Hori	1484.948	PK	54.4	25.1	5.8	34.0	51.3	73.9	22.6	
Hori	2227.451	PK	50.3	26.5	6.3	32.8	50.3	73.9	23.6	
Hori	2483.500	PK	46.7	26.8	6.5	32.6	47.4	73.9	26.5	
Hori	3523.948	PK	48.5	28.5	7.2	32.2	52.0	73.9	21.9	
Hori	4960.000	PK	40.3	31.5	8.6	31.7	48.7	73.9	25.2	Floor noise
Hori	7440.000	PK	42.2	35.5	9.9	32.7	54.9	73.9	19.0	Floor noise
Hori	8197.100	PK	43.4	36.2	10.0	32.8	56.8	73.9	17.1	
Hori	9920.000	PK	41.3	37.2	10.7	33.4	55.8	73.9	18.1	Floor noise
Hori	1039.500	AV	56.7	23.7	5.4	35.2	50.6	53.9	3.3	
Hori	1113.720	AV	50.5	24.0	5.5	35.0	45.0	53.9	8.9	
Hori	1484.948	AV	48.6	25.1	5.8	34.0	45.5	53.9	8.4	
Hori	2227.451	AV	42.9	26.5	6.3	32.8	42.9	53.9	11.0	
Hori	2483.500	AV	32.2	26.8	6.5	32.6	32.9	53.9	21.0	
Hori	3523.948	AV	45.3	28.5	7.2	32.2	48.8	53.9	5.1	
Hori	4960.000	AV	28.8	31.5	8.6	31.7	37.2	53.9	16.7	Floor noise
Hori	7440.000	AV	30.1	35.5	9.9	32.7	42.8	53.9	11.1	Floor noise
Hori	8197.100	AV	34.0	36.2	10.0	32.8	47.4	53.9	6.5	
Hori	9920.000	AV	30.0	37.2	10.7	33.4	44.5	53.9	9.4	Floor noise
Vert	74.250	QP	48.8	6.0	7.7	32.2	30.3	40.0	9.7	
Vert	148.494	QP	44.5	14.7	8.6	32.1	35.7	43.5	7.8	
Vert	445.479	QP	43.1	16.6	10.9	31.9	38.7	46.0	7.3	
Vert	668.224	QP	37.9	19.6	12.3	32.1	37.7	46.0	8.3	
Vert	742.474	QP	33.7	20.2	12.6	31.8	34.7	46.0	11.3	
Vert	884.741	QP	36.7	21.9	13.3	31.0	40.9	46.0	5.1	
Vert	1039.500	PK	58.4	23.7	5.4	35.2	52.3	73.9	21.6	
Vert	1113.720	PK	52.0	24.0	5.5	35.0	46.5	73.9	27.4	
Vert	1484.948	PK	51.6	25.1	5.8	34.0	48.5	73.9	25.4	
Vert	2227.451	PK	48.7	26.5	6.3	32.8	48.7	73.9	25.2	
Vert	2483.500	PK	45.0	26.8	6.5	32.6	45.7	73.9	28.2	
Vert	3523.948	PK	49.1	28.5	7.2	32.2	52.6	73.9	21.3	
Vert	4960.000	PK	40.4	31.5	8.6	31.7	48.8	73.9	25.1	Floor noise
Vert	7440.000	PK	42.1	35.5	9.9	32.7	54.8	73.9	19.1	Floor noise
Vert	8197.100	PK	43.8	36.2	10.0	32.8	57.2	73.9	16.7	
Vert	9920.000	PK	42.1	37.2	10.7	33.4	56.6	73.9	17.3	Floor noise
Vert	1039.500	AV	53.9	23.7	5.4	35.2	47.8	53.9	6.1	
Vert	1113.720	AV	47.9	24.0	5.5	35.0	42.4	53.9	11.5	
Vert	1484.948	AV	44.0	25.1	5.8	34.0	40.9	53.9	13.0	
Vert	2227.451	AV	41.9	26.5	6.3	32.8	41.9	53.9	12.0	
Vert	2483.500	AV	31.2	26.8	6.5	32.6	31.9	53.9	22.0	
Vert	3523.948	AV	44.4	28.5	7.2	32.2	47.9	53.9	6.0	
Vert	4960.000	AV	28.7	31.5	8.6	31.7	37.1	53.9	16.8	Floor noise
Vert	7440.000	AV	30.0	35.5	9.9	32.7	42.7	53.9	11.2	Floor noise
Vert	8197.100	AV	34.7	36.2	10.0	32.8	48.1	53.9	5.8	
Vert	9920.000	AV	30.1	37.2	10.7	33.4	44.6	53.9	9.3	Floor noise

Result = Reading + Ant Factor + Loss (Cable+Attenuator+Filter+Distance factor(above 1 GHz)) - Gain(Amplifier)

*Other frequency noises omitted in this report were not seen or had enough margin (more than 20 dB).

Distance factor: 1 GHz - 10 GHz 20log (4.3 m / 3.0 m) = 3.13 dB
 10 GHz - 26.5 GHz 20log (1.0 m / 3.0 m) = -9.5 dB

***These results have sufficient margin without taking account Dwell time factor.**

UL Japan, Inc.

Ise EMC Lab.

4383-326 Asama-cho, Ise-shi, Mie-ken 516-0021 JAPAN

Telephone : +81 596 24 8999

Facsimile : +81 596 24 8124

Radiated Spurious Emission
(Reference Plot for band-edge)

Test place Ise EMC Lab. No.3 Semi Anechoic Chamber
Report No. 11394939H
Date August 22, 2016
Temperature / Humidity 23 deg. C / 56 % RH
Engineer Hiroyuki Furutaka
Mode Tx, Hopping Off, 3DH5 2480 MHz

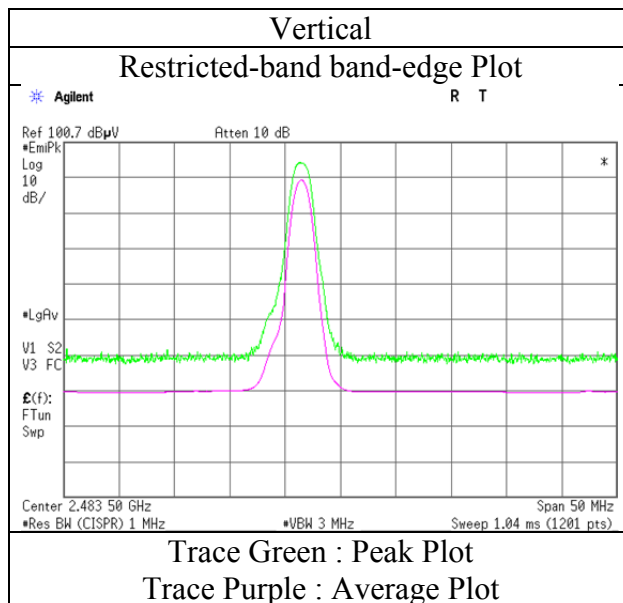
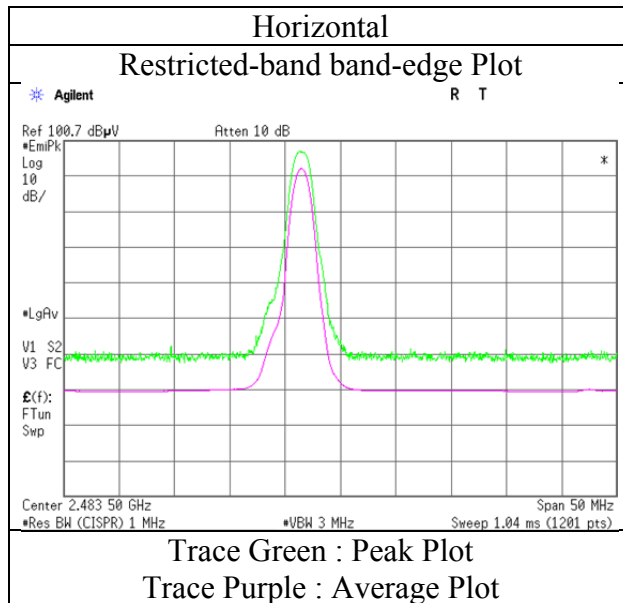

* Final result of restricted band edge was shown in tabular data.

Radiated Spurious Emission (Plot data, Worst case)

Test place	Ise EMC Lab. No.3 Semi Anechoic Chamber		
Report No.	11394939H		
Date	August 22, 2016	August 23, 2016	August 24, 2016
Temperature / Humidity	23 deg. C / 56 % RH	23deg. C / 53% RH	26deg. C / 48% RH
Engineer	Hiroyuki Furutaka (1 GHz - 10 GHz)	Hiroyuki Furutaka (10 GHz - 26.5 GHz)	Hiroyuki Furutaka (Below 1 GHz)
Mode	Tx, Hopping Off, 3DH5 2441 MHz		

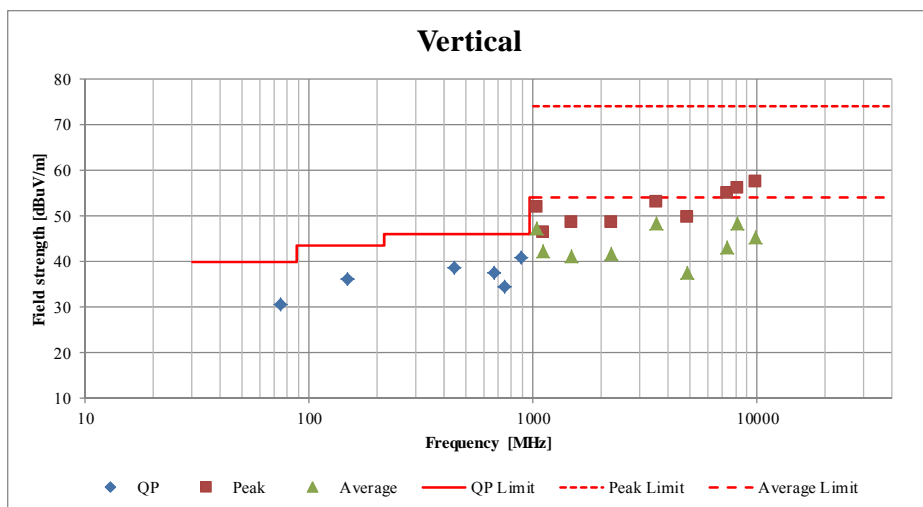
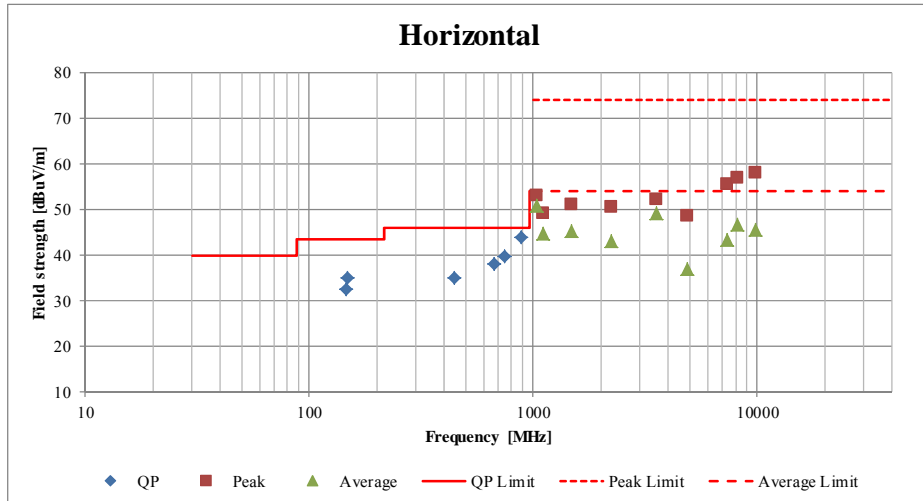

*These plots data contains sufficient number to show the trend of characteristic features for EUT.

Conducted Spurious Emission

Test place	Ise EMC Lab. No.6 Measurement Room
Report No.	11394939H
Date	August 3, 2016
Temperature / Humidity	24 deg. C / 49 % RH
Engineer	Hiroyuki Furutaka
Mode	Tx, Hopping Off, DH5

2402 MHz

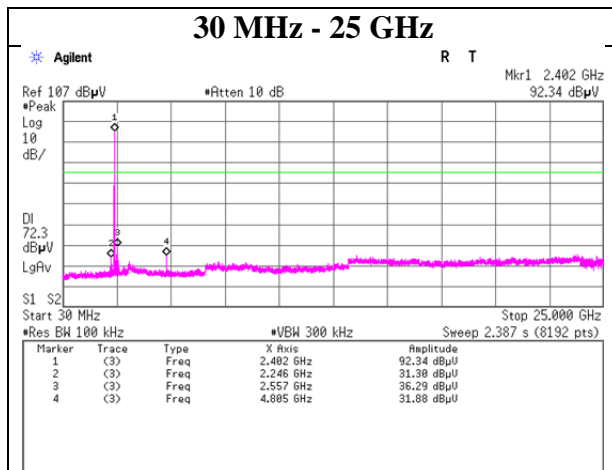
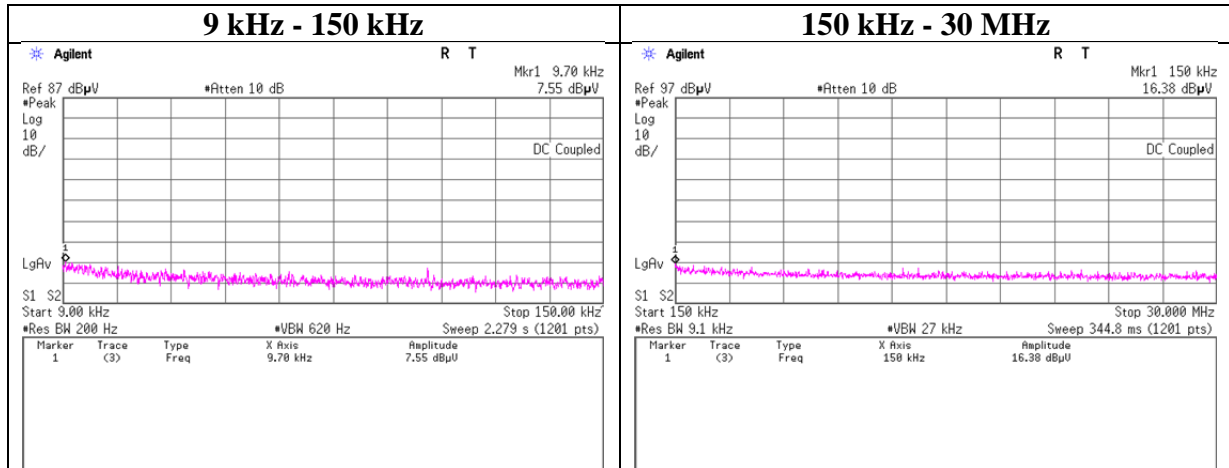

Conducted Spurious Emission

Test place	Ise EMC Lab. No.6 Measurement Room
Report No.	11394939H
Date	August 3, 2016
Temperature / Humidity	24 deg. C / 49 % RH
Engineer	Hiroyuki Furutaka
Mode	Tx, Hopping Off, DH5

2441 MHz

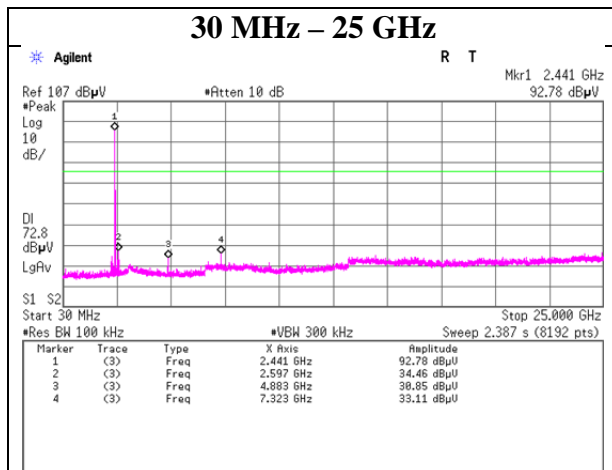
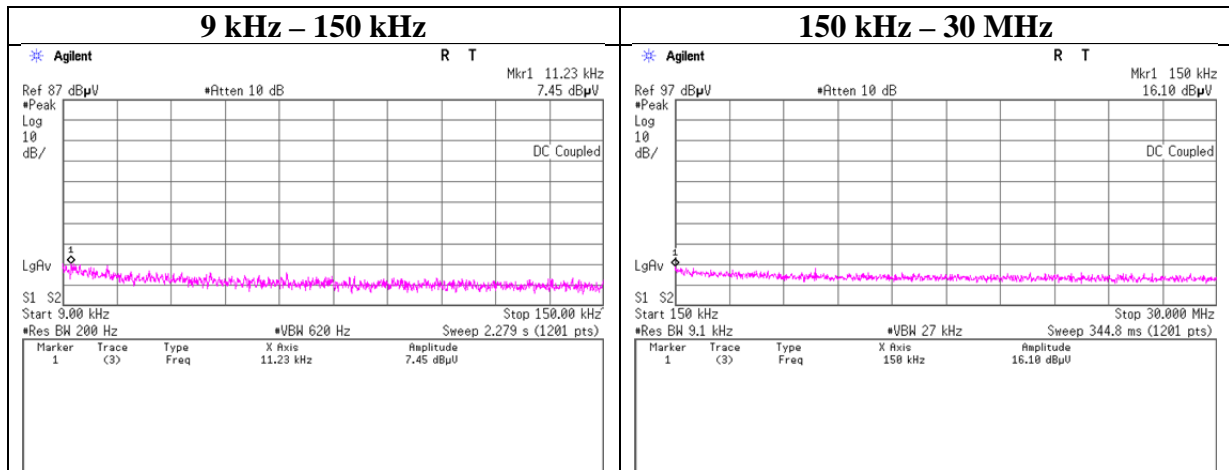

Conducted Spurious Emission

Test place	Ise EMC Lab. No.6 Measurement Room
Report No.	11394939H
Date	August 3, 2016
Temperature / Humidity	24 deg. C / 49 % RH
Engineer	Hiroyuki Furutaka
Mode	Tx, Hopping Off, DH5

2480 MHz

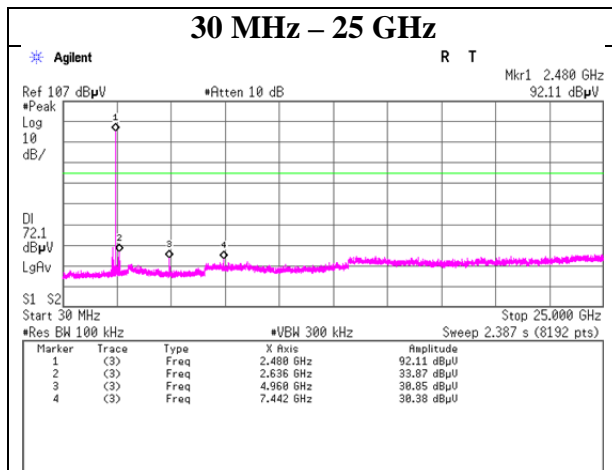
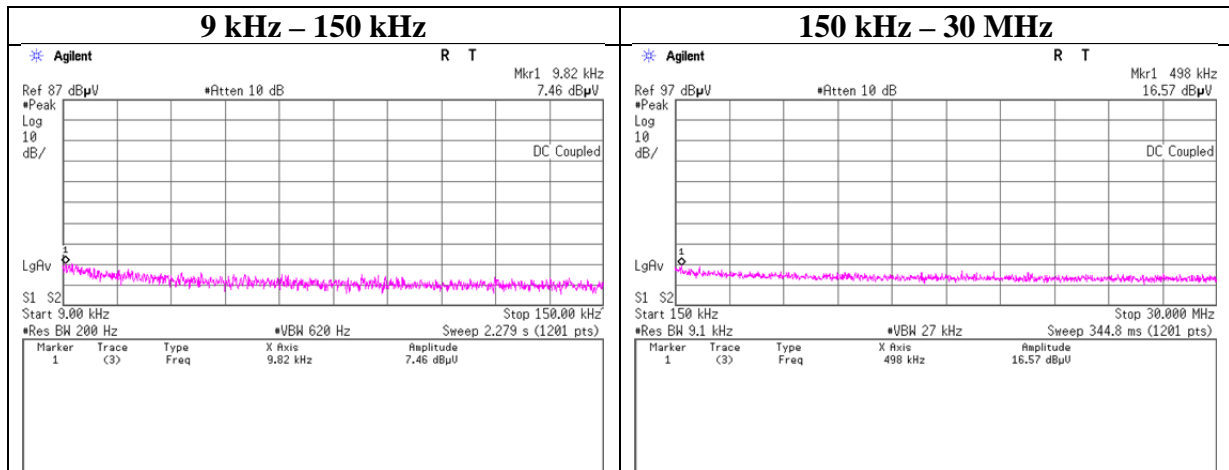

Conducted Spurious Emission

Test place	Ise EMC Lab. No.6 Measurement Room
Report No.	11394939H
Date	August 3, 2016
Temperature / Humidity	24 deg. C / 49 % RH
Engineer	Hiroyuki Furutaka
Mode	Tx, Hopping Off, 3DH5

2402 MHz

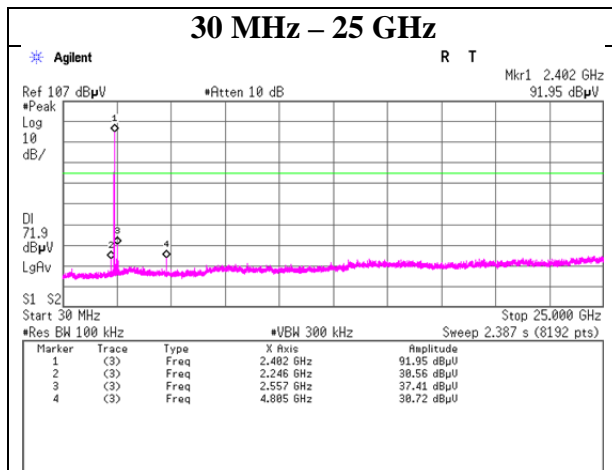
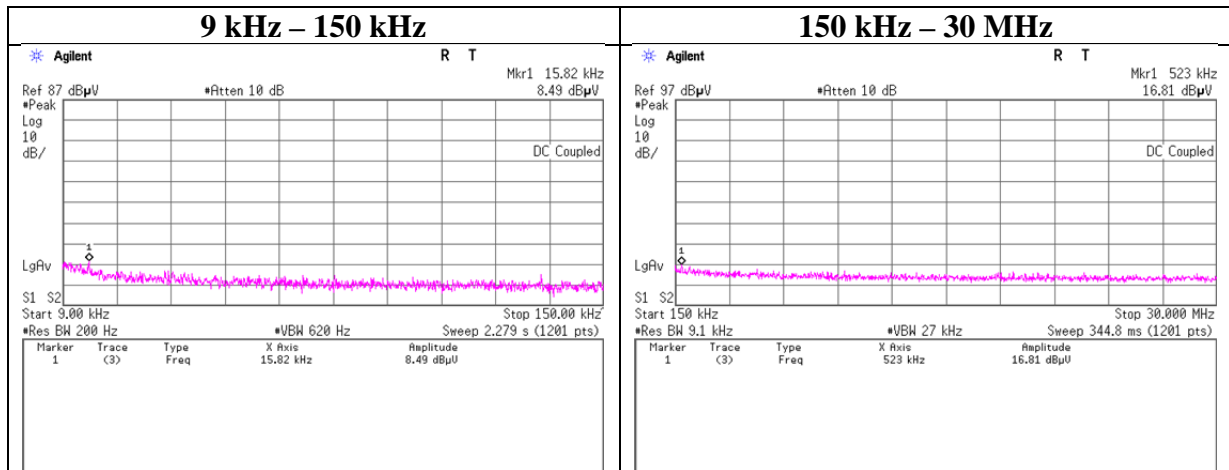

Conducted Spurious Emission

Test place	Ise EMC Lab. No.6 Measurement Room
Report No.	11394939H
Date	August 3, 2016
Temperature / Humidity	24 deg. C / 49 % RH
Engineer	Hiroyuki Furutaka
Mode	Tx, Hopping Off, 3DH5

2441 MHz

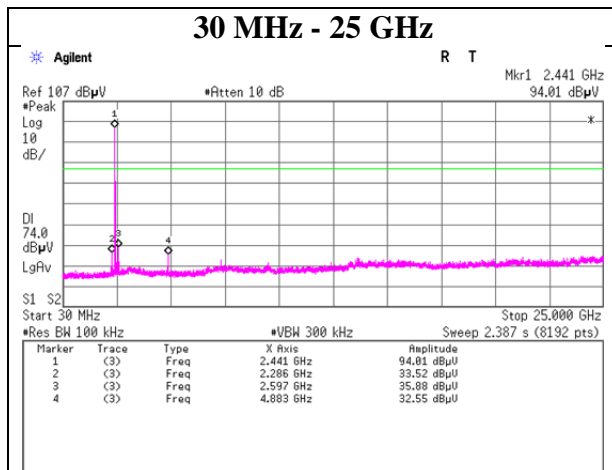
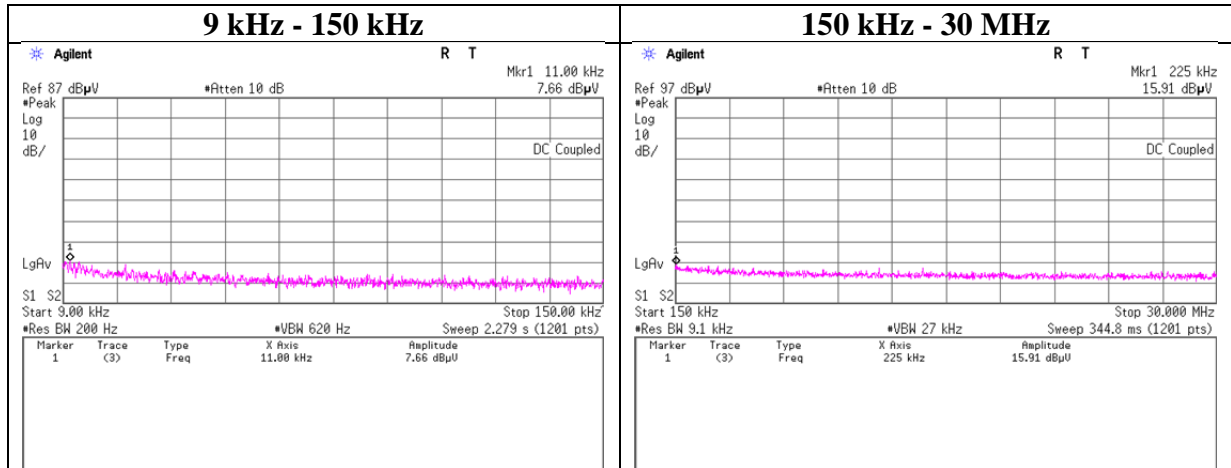

Conducted Spurious Emission

Test place	Ise EMC Lab. No.6 Measurement Room
Report No.	11394939H
Date	August 3, 2016
Temperature / Humidity	24 deg. C / 49 % RH
Engineer	Hiroyuki Furutaka
Mode	Tx, Hopping Off, 3DH5

2480 MHz

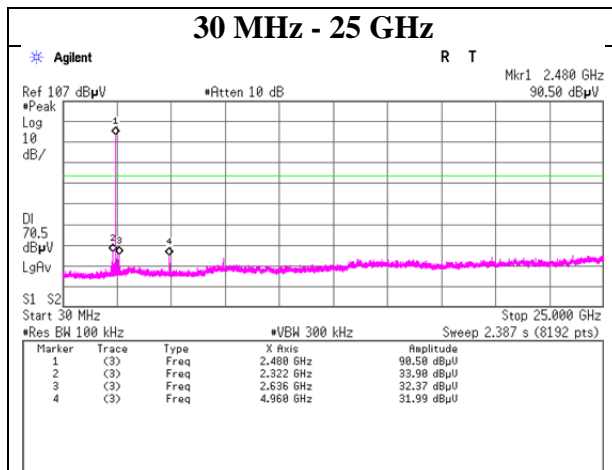
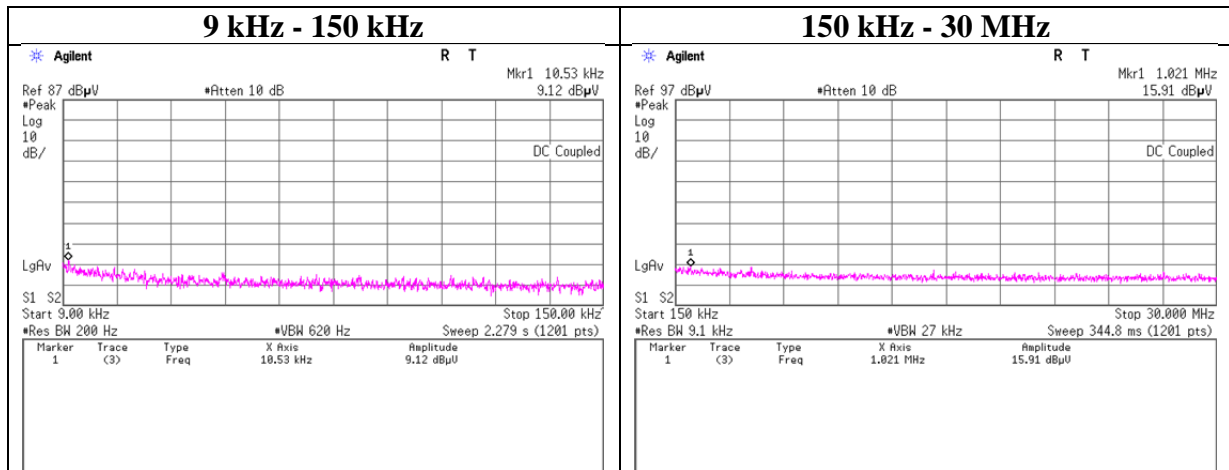

Conducted Emission Band Edge compliance

Test place	Ise EMC Lab. No.6 Measurement Room
Report No.	11394939H
Date	August 3, 2016
Temperature / Humidity	24 deg. C / 49 % RH
Engineer	Hiroyuki Furutaka
Mode	Tx (Hopping on/off) DHS

Hopping On

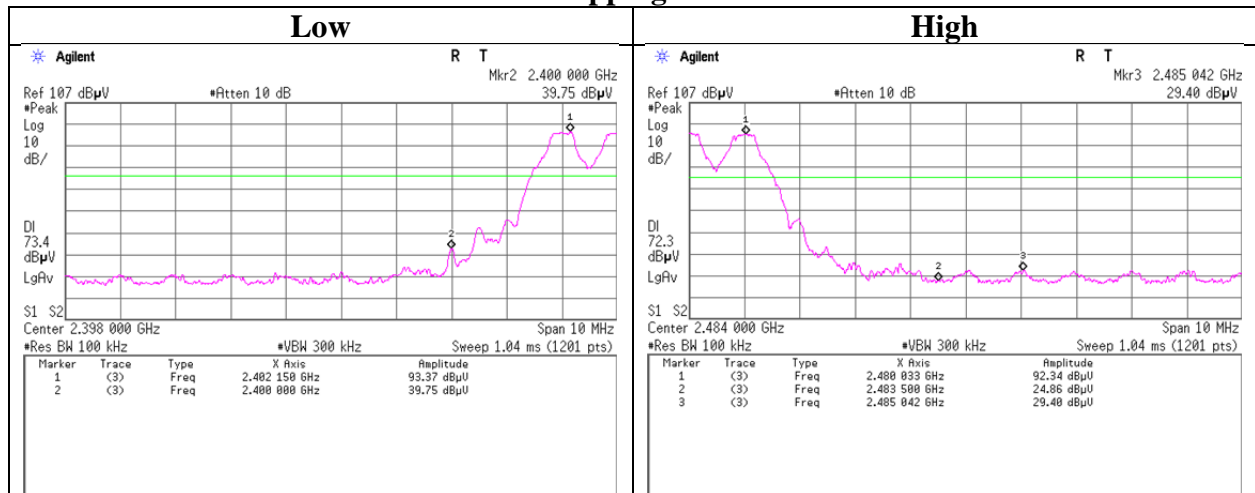

Hopping Off

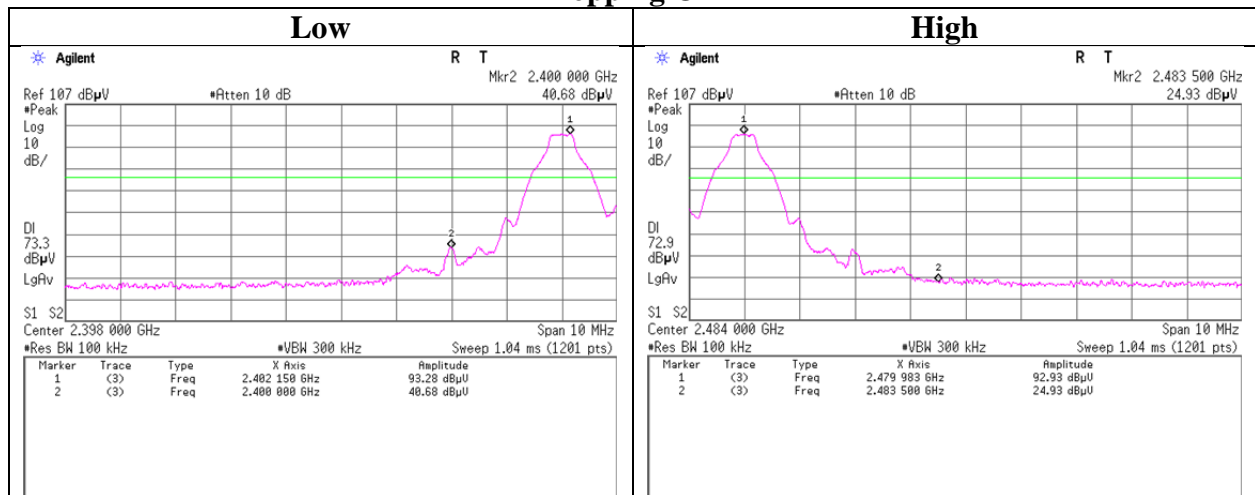

UL Japan, Inc.

Ise EMC Lab.

4383-326 Asama-cho, Ise-shi, Mie-ken 516-0021 JAPAN

Telephone : +81 596 24 8999

Facsimile : +81 596 24 8124

Conducted Emission Band Edge compliance

Test place	Ise EMC Lab. No.6 Measurement Room
Report No.	11394939H
Date	August 3, 2016
Temperature / Humidity	24 deg. C / 49 % RH
Engineer	Hiroyuki Furutaka
Mode	Tx (Hopping on/off) 3DH5

Hopping On

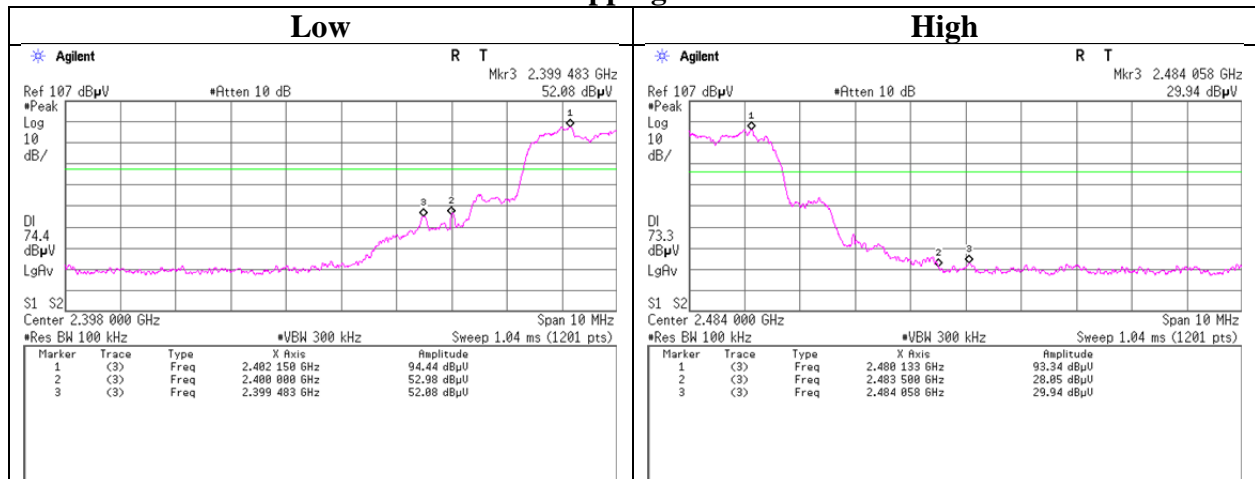

Hopping Off

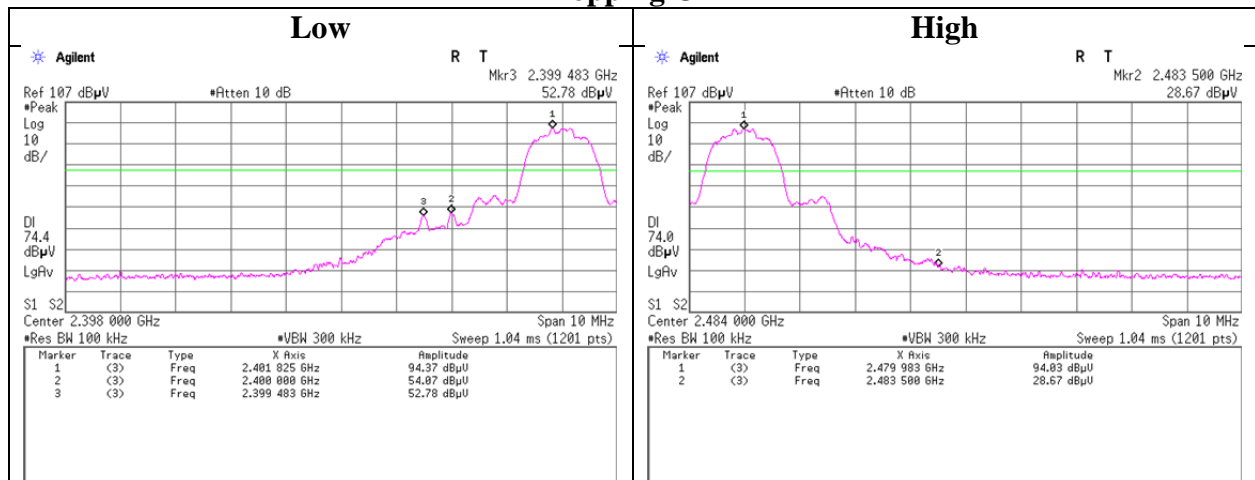

99% Occupied Bandwidth

Test place	Ise EMC Lab. No.6 Measurement Room
Report No.	11394939H
Date	August 3, 2016
Temperature / Humidity	24 deg. C / 49 % RH
Engineer	Hiroyuki Furutaka
Mode	Tx (Hopping off) DH5/3DH5

Hopping Off, DH5

Hopping Off, 3DH5

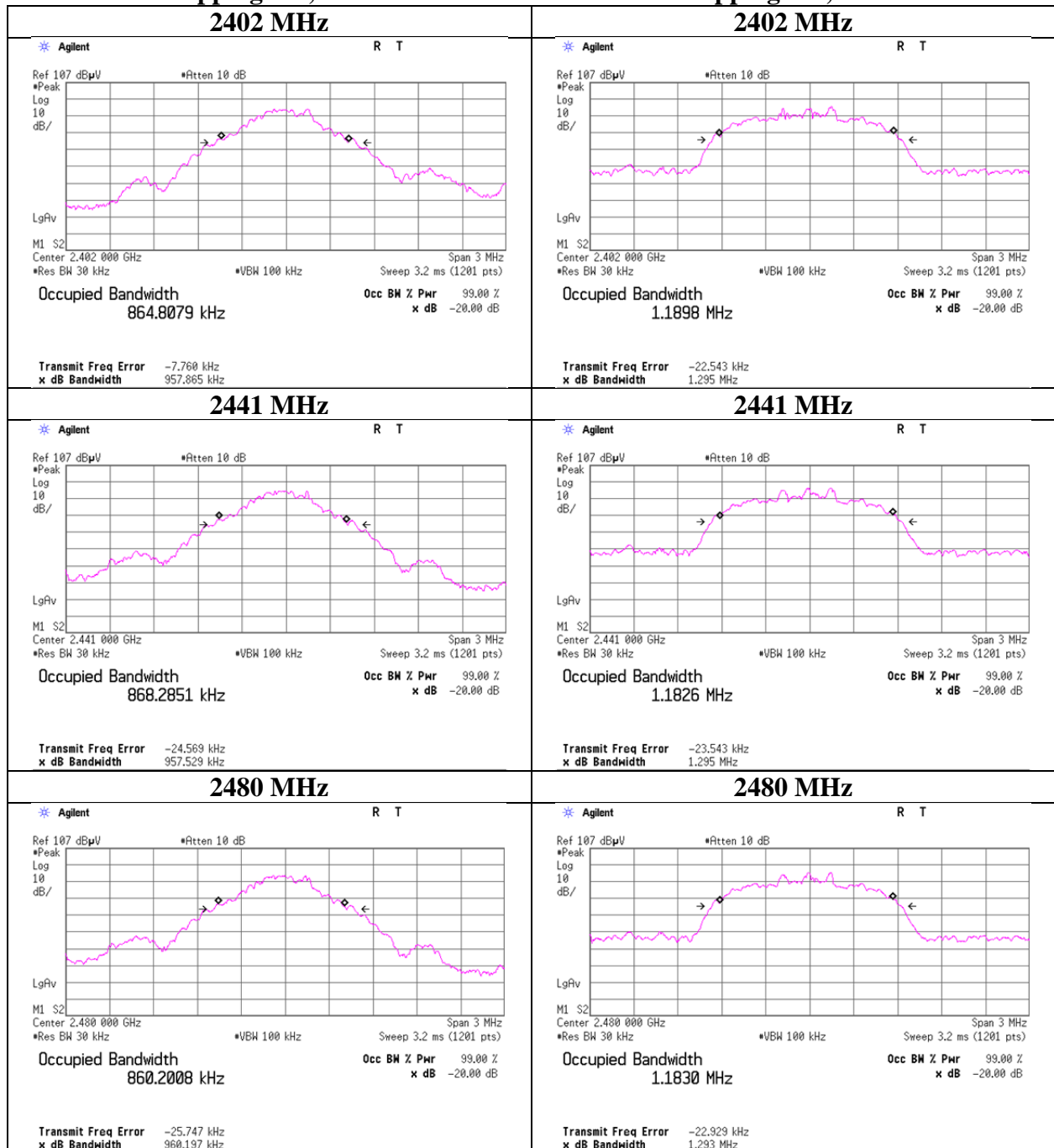

UL Japan, Inc.

Ise EMC Lab.

4383-326 Asama-cho, Ise-shi, Mie-ken 516-0021 JAPAN

Telephone : +81 596 24 8999

Facsimile : +81 596 24 8124

99% Occupied Bandwidth

Test place	Ise EMC Lab. No.6 Measurement Room
Report No.	11394939H
Date	August 3, 2016
Temperature / Humidity	24 deg. C / 49 % RH
Engineer	Hiroyuki Furutaka
Mode	Tx (Hopping on) DH5/3DH5

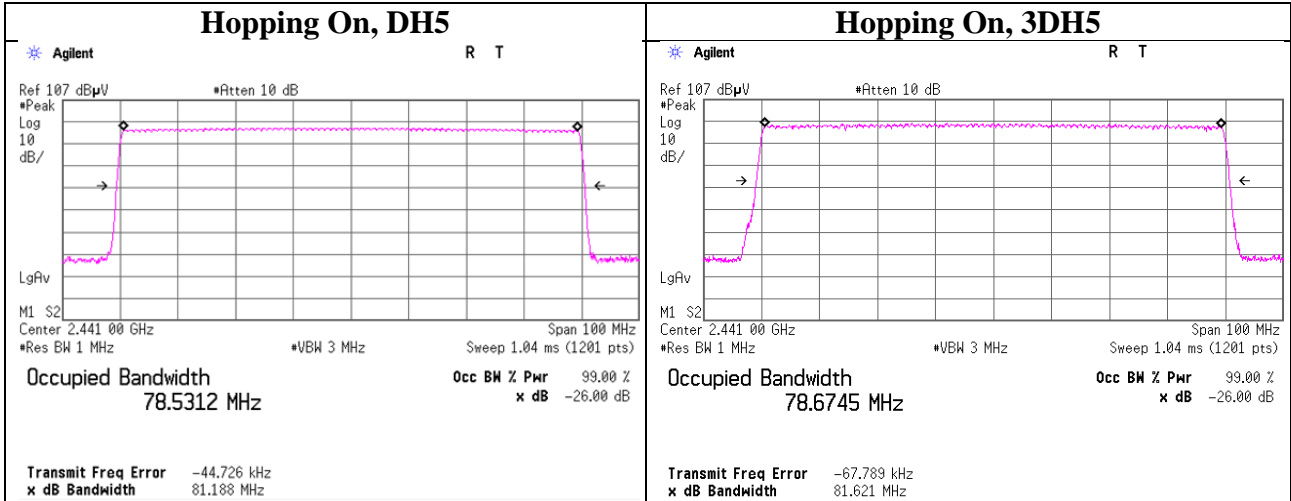

UL Japan, Inc.

Ise EMC Lab.

4383-326 Asama-cho, Ise-shi, Mie-ken 516-0021 JAPAN

Telephone : +81 596 24 8999

Facsimile : +81 596 24 8124

APPENDIX 2: Test instruments

Test equipment

Control No.	Instrument	Manufacturer	Model No	Serial No	Test Item	Calibration Date * Interval(month)
MRENT-130	Spectrum Analyzer	Agilent	E4440A	MY46187750	AT	2016/06/03 * 12
MPM-16	Power Meter	Agilent	8990B	MY51000271	AT	2016/04/07 * 12
MCC-137	Microwave cable	HUBER+SUHNER	SUCOFLEX 102	37954/2	AT	2015/10/08 * 12
MPSE-22	Power sensor	Agilent	N1923A	MY54070003	AT	2016/04/07 * 12
MAT-20	Attenuator(10dB)(above 1GHz)	HIROSE ELECTRIC CO.,LTD.	AT-110	-	AT	2016/01/08 * 12
MAT-10	Attenuator(10dB)	Weinschel Corp	2	BL1173	AT	2015/11/10 * 12
MCC-38	Coaxial Cable	UL Japan	-	-	AT	2015/12/07 * 12
MOS-13	Thermo-Hygrometer	Custom	CTH-180	1301	RE	2016/01/21 * 12
MAEC-03	Semi Anechoic Chamber(NSA)	TDK	Semi Anechoic Chamber 3m	DA-10005	RE	2015/10/01 * 12
MJM-16	Measure	KOMELON	KMC-36	-	RE	-
COTS-MEMI	EMI measurement program	TSJ	TEPTO-DV	-	RE	-
MSA-03	Spectrum Analyzer	Agilent	E4448A	MY44020357	RE	2016/05/19 * 12
MHA-20	Horn Antenna 1-18GHz	Schwarzbeck	BBHA9120D	258	RE	2016/05/29 * 12
MCC-167	Microwave Cable	Junkosha	MWX221	1404S374(1m) / 1405S074(5m)	RE	2016/05/20 * 12
MPA-11	MicroWave System Amplifier	Agilent	83017A	MY39500779	RE	2016/03/24 * 12
MMM-08	DIGITAL HiTESTER	Hioki	3805	051201197	RE	2016/01/13 * 12
MHF-25	High Pass Filter 3.5-18.0GHz	UL Japan	HPF SELECTOR	001	RE	2015/09/16 * 12
MHA-16	Horn Antenna 15-40GHz	Schwarzbeck	BBHA9170	BBHA9170306	RE	2016/05/29 * 12
MSA-16	Spectrum Analyzer	Agilent	E4440A	MY46186390	RE	2016/02/08 * 12
MTR-08	Test Receiver	Rohde & Schwarz	ESCI	100767	RE	2015/09/02 * 12
MBA-03	Biconical Antenna	Schwarzbeck	BBA9106	1915	RE	2015/10/11 * 12
MLA-22	Logperiodic Antenna(200-1000MHz)	Schwarzbeck	VUSLP9111B	911B-191	RE	2016/01/30 * 12
MCC-51	Coaxial cable	UL Japan	-	-	RE	2016/07/26 * 12
MAT-70	Attenuator(6dB)	Agilent	8491A-006	MY52460153	RE	2016/04/05 * 12
MPA-13	Pre Amplifier	SONOMA INSTRUMENT	310	260834	RE	2016/03/24 * 12

The expiration date of the calibration is the end of the expired month.

All equipment is calibrated with valid calibrations. Each measurement data is traceable to the national or international standards.

As for some calibrations performed after the tested dates, those test equipment have been controlled by means of an unbroken chains of calibrations.

**Test Item: RE: Radiated Emission test
AT: Antenna Terminal Conducted test**

UL Japan, Inc.

Ise EMC Lab.

4383-326 Asama-cho, Ise-shi, Mie-ken 516-0021 JAPAN

Telephone : +81 596 24 8999

Facsimile : +81 596 24 8124