



# RADIO TEST REPORT

Test Report No. : 10184498H-A-R2

**Applicant** : Mitsubishi Electric Corporation Sanda Works  
**Type of Equipment** : Display Audio  
**Model No.** : NR-244UH  
NR-245UH  
**FCC ID** : UJHNR244245BTWL  
**Test regulation** : FCC Part 15 Subpart C: 2014  
**Test Result** : Complied

1. This test report shall not be reproduced in full or partial, without the written approval of UL Japan, Inc.
2. The results in this report apply only to the sample tested.
3. This sample tested is in compliance with the above regulation.
4. The test results in this report are traceable to the national or international standards.
5. This test report must not be used by the customer to claim product certification, approval, or endorsement by NVLAP, NIST, or any agency of the Federal Government.
6. This report is a revised version of 10184498H-A-R1. 10184498H-A-R1 is replaced with this report.

**Date of test:** January 15 to 29, 2014

**Representative test engineer:**

  
Satofumi Matsuyama  
Engineer  
Consumer Technology Division

**Approved by:**

  
Masanori Nishiyama  
Manager  
Consumer Technology Division



NVLAP LAB CODE: 200572-0

This laboratory is accredited by the NVLAP LAB CODE 200572-0, U.S.A. The tests reported herein have been performed in accordance with its terms of accreditation. \*As for the range of Accreditation in NVLAP, you may refer to the WEB address, <http://www.ul.com/japan/jpn/pages/services/emc/about/mark1/index.jsp#nvlap>

**UL Japan, Inc.**  
**Ise EMC Lab.**

4383-326 Asama-cho, Ise-shi, Mie-ken 516-0021 JAPAN  
Telephone : +81 596 24 8999  
Facsimile : +81 596 24 8124



<b>CONTENTS</b>	<b>PAGE</b>
<b>SECTION 1: Customer information.....</b>	<b>4</b>
<b>SECTION 2: Equipment under test (E.U.T.).....</b>	<b>4</b>
<b>SECTION 3: Test specification, procedures &amp; results.....</b>	<b>5</b>
<b>SECTION 4: Operation of E.U.T. during testing.....</b>	<b>8</b>
<b>SECTION 5: Radiated Spurious Emission .....</b>	<b>11</b>
<b>SECTION 6: Antenna Terminal Conducted Tests.....</b>	<b>12</b>
<b>APPENDIX 1: Data of EMI test.....</b>	<b>13</b>
20dB Bandwidth and Carrier Frequency Separation.....	13
Number of Hopping Frequency .....	16
Dwell time.....	18
Maximum Peak Output Power .....	21
Radiated Spurious Emission .....	23
Conducted Spurious Emission .....	34
99%Occupied Bandwidth .....	48
<b>APPENDIX 2: Test instruments .....</b>	<b>50</b>
<b>APPENDIX 3: Photographs of test setup .....</b>	<b>51</b>
Radiated Spurious Emission .....	51

---

**UL Japan, Inc.**

**Ise EMC Lab.**

4383-326 Asama-cho, Ise-shi, Mie-ken 516-0021 JAPAN

Telephone : +81 596 24 8999

Facsimile : +81 596 24 8124

## **SECTION 1: Customer information**

Company Name : Mitsubishi Electric Corporation Sanda Works  
Address : 2-3-33, Miwa, Sanda-city, Hyogo, 669-1513, Japan  
Telephone Number : +81-79-559-3623  
Facsimile Number : +81-79-559-3875  
Contact Person : Kenji Otani

## **SECTION 2: Equipment under test (E.U.T.)**

### **2.1 Identification of E.U.T.**

Type of Equipment : Display Audio  
Model No. : NR-244UH  
NR-245UH  
Serial No. : Refer to Section 4, Clause 4.2  
Rating : DC 12.0V  
Receipt Date of Sample : January 14, 2014  
Country of Mass-production : Thailand  
Condition of EUT : Production prototype  
(Not for Sale: This sample is equivalent to mass-produced items.)  
Modification of EUT : No Modification by the test lab

### **2.2 Product Description**

#### **General Specification**

Clock frequency(ies) in the system : 26MHz

#### **Radio Specification**

##### **[Bluetooth (Ver. 3.0 with EDR function)]**

Radio Type : Transceiver  
Frequency of Operation : 2402-2480MHz  
Modulation : FHSS  
Power Supply (inner) : DC 3.3V  
Antenna type : Inverted F Antenna  
Antenna Gain : 0.11dBi

##### **[GPS]**

Radio Type : Receiver  
Frequency of Operation : 1575.42MHz  
Modulation : CDMA  
Power Supply (radio part input) : DC 3.3V  
Antenna type : Inverted F Antenna  
Antenna Gain : 0dBi

\*Co-location EMC tests were skipped based on FCC EMC co-location test policy of TCB workshop 2005 May, because it will be deemed that the compliance can be presumed under this filing condition by manufacturer declaration.

\*Model No. NR-244UH and NR-245UH have Internal and External Amplifiers.

The test was performed on Model No. NR-244UH with External Amplifier and Model No. NR-245UH with Internal Amplifier according to the customer's request.

---

**UL Japan, Inc.**

**Ise EMC Lab.**

4383-326 Asama-cho, Ise-shi, Mie-ken 516-0021 JAPAN

Telephone : +81 596 24 8999

Facsimile : +81 596 24 8124

## **SECTION 3: Test specification, procedures & results**

### **3.1 Test Specification**

Test Specification : FCC Part 15 Subpart C: 2014, final revised on May 1, 2014 and effective June 2, 2014

Title : FCC 47CFR Part15 Radio Frequency Device Subpart C Intentional Radiators  
Section 15.207 Conducted limits  
Section 15.247 Operation within the bands 902-928MHz,  
2400-2483.5MHz, and 5725-5850MHz

\* The revision on May 1, 2014 does not affect the test specification applied to the EUT.

### **3.2 Procedures and results**

Item	Test Procedure	Specification	Worst Margin	Results	Remarks
Conducted Emission	FCC: ANSI C63.4:2003 7. AC powerline conducted emission measurements IC: RSS-Gen 7.2.4	FCC: Section 15.207 ----- IC: RSS-Gen 7.2.4		N/A	*1)
Carrier Frequency Separation	FCC: FCC Public Notice DA 00-705 IC: -	FCC: Section15.247(a)(1) ----- IC: RSS-210 A8.1 (b)		Complied	Conducted
20dB Bandwidth	FCC: FCC Public Notice DA 00-705 IC: -	FCC: Section15.247(a)(1) ----- IC: RSS-210 A8.1 (a)		Complied	Conducted
Number of Hopping Frequency	FCC: FCC Public Notice DA 00-705 IC: -	FCC: Section15.247(a)(1)(iii) ----- IC: RSS-210 A8.1 (d)	See data.	Complied	Conducted
Dwell time	FCC: FCC Public Notice DA 00-705 IC: -	FCC: Section15.247(a)(1)(iii) ----- IC: RSS-210 A8.1 (d)		Complied	Conducted
Maximum Peak Output Power	FCC: FCC Public Notice DA 00-705 IC: RSS-Gen 4.8	FCC: Section15.247 (b)(1) ----- IC: RSS-210 A8.4 (2)		Complied	Conducted
Spurious Emission & Band Edge Compliance	FCC: FCC Public Notice DA 00-705 IC: RSS-Gen 4.9	FCC: Section15.247(d) ----- IC: RSS-210 A8.5 RSS-Gen 6 and 7.2.3	10.0dB 135.199MHz, QP, Hori.	Complied	Conducted/ Radiated

Note: UL Japan, Inc.'s EMI Work Procedures No. 13-EM-W0420 and 13-EM-W0422.

\*1) The test is not applicable since the EUT is not the device that is designed to be connected to the public utility (AC) power line.

\* In case any questions arise about test procedure, ANSI C63.4: 2003 is also referred.

**UL Japan, Inc.**

**Ise EMC Lab.**

4383-326 Asama-cho, Ise-shi, Mie-ken 516-0021 JAPAN

Telephone : +81 596 24 8999

Facsimile : +81 596 24 8124

**FCC 15.31 (e)**

The EUT is a battery-operated device and test was performed with the full-charged battery voltage. Therefore, this EUT complies with the requirement.

**FCC Part 15.203 Antenna requirement**

It is impossible for end users to replace the antenna, because the antenna is mounted inside of the EUT. Therefore, the equipment complies with the antenna requirement of Section 15.203.

**3.3 Addition to standard**

Item	Test Procedure	Specification	Worst margin	Results	Remarks
99% Occupied Bandwidth	IC: RSS-Gen 4.6.1	IC: RSS-Gen 4.6.1	N/A	-	Conducted

Other than above, no addition, exclusion nor deviation has been made from the standard.

**3.4 Uncertainty**

The following uncertainties have been calculated to provide a confidence level of 95% using a coverage factor k=2.

Test room (semi-anechoic chamber)	Radiated emission						
	(3m*)(+dB)				(1m*)(+dB)		(0.5m*)(+dB)
	9kHz -30MHz	30MHz -300MHz	300MHz -1GHz	1GHz -10GHz	10GHz -18GHz	18GHz -26.5GHz	26.5GHz -40GHz
No.1	4.0dB	5.1dB	5.0dB	5.1dB	6.0dB	4.9dB	4.3dB
No.2	3.9dB	5.2dB	5.0dB	4.9dB	5.9dB	4.7dB	4.2dB
No.3	4.3dB	5.1dB	5.2dB	5.2dB	6.0dB	4.8dB	4.2dB
No.4	4.6dB	5.2dB	5.0dB	5.2dB	6.0dB	5.7dB	4.2dB

\*3m/1m/0.5m = Measurement distance

Power meter (+dB)	
Below 1GHz	Above 1GHz
0.7dB	1.5dB

Antenna terminal conducted emission and Power density (+dB)			Antenna terminal conducted emission (+dB)		Channel power (+dB)
Below 1GHz	1GHz-3GHz	3GHz-18GHz	18GHz-26.5GHz	26.5GHz-40GHz	
1.5dB	1.7dB	2.8dB	2.8dB	2.9dB	2.6dB

Radiated emission test(3m)

The data listed in this test report has enough margin, more than the site margin.

### 3.5 Test Location

UL Japan, Inc. Ise EMC Lab. \*NVLAP Lab. code: 200572-0  
 4383-326 Asama-cho, Ise-shi, Mie-ken 516-0021 JAPAN  
 Telephone : +81 596 24 8999 Facsimile : +81 596 24 8124

	IC Registration Number	Width x Depth x Height (m)	Size of reference ground plane (m) / horizontal conducting plane	Other rooms
No.1 semi-anechoic chamber	2973C-1	19.2 x 11.2 x 7.7m	7.0 x 6.0m	No.1 Power source room
No.2 semi-anechoic chamber	2973C-2	7.5 x 5.8 x 5.2m	4.0 x 4.0m	-
No.3 semi-anechoic chamber	2973C-3	12.0 x 8.5 x 5.9m	6.8 x 5.75m	No.3 Preparation room
No.3 shielded room	-	4.0 x 6.0 x 2.7m	N/A	-
No.4 semi-anechoic chamber	2973C-4	12.0 x 8.5 x 5.9m	6.8 x 5.75m	No.4 Preparation room
No.4 shielded room	-	4.0 x 6.0 x 2.7m	N/A	-
No.5 semi-anechoic chamber	-	6.0 x 6.0 x 3.9m	6.0 x 6.0m	-
No.6 shielded room	-	4.0 x 4.5 x 2.7m	4.0 x 4.5 m	-
No.6 measurement room	-	4.75 x 5.4 x 3.0m	4.75 x 4.15 m	-
No.7 shielded room	-	4.7 x 7.5 x 2.7m	4.7 x 7.5m	-
No.8 measurement room	-	3.1 x 5.0 x 2.7m	N/A	-
No.9 measurement room	-	8.8 x 4.6 x 2.8m	2.4 x 2.4m	-
No.11 measurement room	-	6.2 x 4.7 x 3.0m	2.4 x 3.4m	-

\* Size of vertical conducting plane (for Conducted Emission test) : 2.0 x 2.0m for No.1, No.2, No.3, and No.4 semi-anechoic chambers and No.3 and No.4 shielded rooms.

### 3.6 Data of EMI, Test instruments, and Test set up

Refer to APPENDIX.

## UL Japan, Inc. Ise EMC Lab.

4383-326 Asama-cho, Ise-shi, Mie-ken 516-0021 JAPAN  
 Telephone : +81 596 24 8999  
 Facsimile : +81 596 24 8124

## **SECTION 4: Operation of E.U.T. during testing**

### **4.1 Operating Mode(s)**

Bluetooth (BT): Transmitting (Tx), Payload: PRBS9  
Inquiry

Details of Operating Mode(s)

Test Item	Mode	Tested frequency
Spurious Emission (Conducted/Radiated)	Tx (Hopping off) DH5, 3DH5	2402MHz 2441MHz 2480MHz
Carrier Frequency Separation 20dB Bandwidth	Tx (Hopping on) DH5, 3DH5 Inquiry	2402MHz 2441MHz 2480MHz
Number of Hopping Frequency	Tx (Hopping on) DH5, 3DH5 Inquiry	-
Dwell time	Tx (Hopping on), -DH1, DH3, DH5 -3DH1, 3DH3, 3DH5 Inquiry	-
Maximum Peak Output Power	Tx (Hopping off) DH5, 2DH5, 3DH5 Inquiry	2402MHz 2441MHz 2480MHz
Band Edge Compliance (Conducted)	Tx DH5, 3DH5 -Hopping on -Hopping off	2402MHz 2480MHz
99% Occupied Bandwidth	Tx DH5, 3DH5 -Hopping on -Hopping off Inquiry	2402MHz 2441MHz 2480MHz
<p>*As a result of preliminary test, the formal test was performed with the above modes, which had the maximum payload length (except Dwell time test)  *We removed 2DH mode (2 Mb/s EDR: pi/4DQPSK) except power measurement by using 3DH mode (3 Mb/s EDR:8DPSK) as a representative.  *EUT has the power settings by the software as follows;  Power settings: 0dBm  Software: 1.0  *This setting of software is the worst case.  Any conditions under the normal use do not exceed the condition of setting.  In addition, end users cannot change the settings of the output power of the product.</p>		

Details of tested models

Model No.	NR-244UH	NR-245UH
Antenna terminal conducted	X	-
Spurious Emission (Radiated)	X	X
	[DH5] 2402MHz 2441MHz 2480MHz [3DH5] 2402MHz 2441MHz 2480MHz	[DH5] 2402MHz 2441MHz 2480MHz *2)

\*1) This model was tested as a representative because the above models embedded same module.

\*2) The test was performed on the mode that has the worst condition in Model No. NR-244UH according to the customer's request.

**UL Japan, Inc.**

**Ise EMC Lab.**

4383-326 Asama-cho, Ise-shi, Mie-ken 516-0021 JAPAN

Telephone : +81 596 24 8999

Facsimile : +81 596 24 8124



## 4.2 Configuration and peripherals

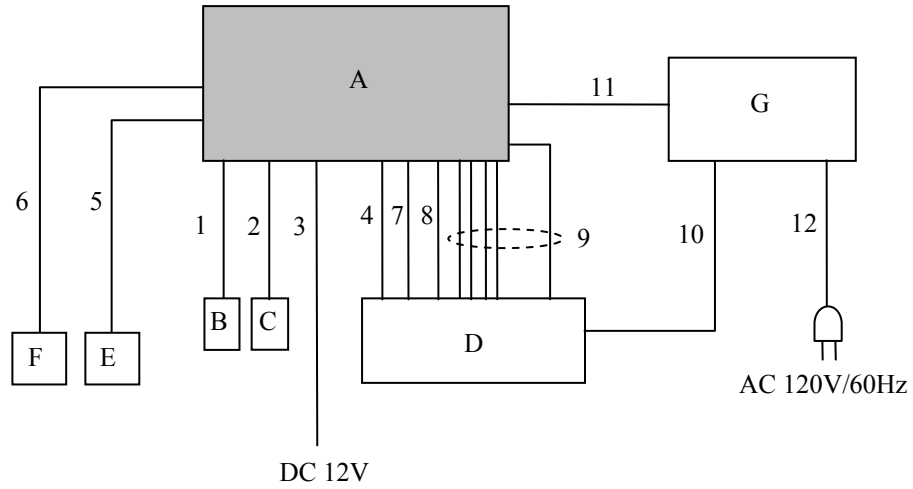

\* Cabling and setup were taken into consideration and test data was taken under worse case conditions.

**Description of EUT**

No.	Item	Model number	Serial number	Manufacturer	Remark
A	Display Audio	NR-244UH	93Y56040 *1) 93Y66023 *2)	Mitsubishi Electric Corporation Sanda Works	EUT
		NR-245UH	93Y66020 *1)		
B	GPS Antenna	-	-	MITSUMI	-
C	75 ohm Terminator	-	-	-	-
D	Jig	-	-	Mitsubishi Electric Corporation Sanda Works	-
E	Speaker	TS-STx5	FM08 47	Pioneer	-
F	Speaker	TS-STx5	FM08 47	Pioneer	-
G	DVD Player	DV-600AV-S	HEKD013328LS	Pioneer	-

\*1) Used for Radiated Spurious Emission test

\*2) Used for Antenna Terminal Conducted tests

**List of cables used**

No.	Name	Length (m)	Shield		Remark
			Cable	Connector	
1	GPS Cable	3.0	Shielded	Shielded	-
2	Signal Cable	0.2	Shielded	Shielded	-
3	DC Cable	3.5	Unshielded	Unshielded	-
4	Audio Cable	2.0	Unshielded	Unshielded	-
5	Audio Cable	2.2	Unshielded	Unshielded	-
6	Audio Cable	2.2	Unshielded	Unshielded	-
7	USB Cable	2.0	Shielded	Shielded	-
8	USB Cable	2.0	Shielded	Shielded	-
9	Signal Cable	2.0	Unshielded	Unshielded	x5
10	Video Cable	5.0	Shielded	Shielded	-
11	HDMI Cable	5.0	Shielded	Shielded	-
12	AC Cable	1.5	Unshielded	Unshielded	-

**UL Japan, Inc.**

**Ise EMC Lab.**

4383-326 Asama-cho, Ise-shi, Mie-ken 516-0021 JAPAN

Telephone : +81 596 24 8999

Facsimile : +81 596 24 8124

## **SECTION 5: Radiated Spurious Emission**

### **Test Procedure**

EUT was placed on a urethane platform of nominal size, 1.0m by 1.5m, raised 0.8m above the conducting ground plane.

The Radiated Electric Field Strength has been measured in a Semi Anechoic Chamber with a ground plane.

The height of the measuring antenna varied between 1 and 4m and EUT was rotated a full revolution in order to obtain the maximum value of the electric field strength.

The measurements were performed for both vertical and horizontal antenna polarization with the Test Receiver, or the Spectrum Analyzer.

The measurements were made with the following detector function of the test receiver and the Spectrum analyzer (in linear mode).

The test was made with the detector (RBW/VBW) in the following table.

When using Spectrum analyzer, the test was made with adjusting span to zero by using peak hold.

### **Test Antennas are used as below;**

Frequency	30MHz to 300MHz	300MHz to 1GHz	Above 1GHz
Antenna Type	Biconical	Logperiodic	Horn

In any 100kHz bandwidth outside the restricted band in which the spread spectrum intentional radiator is operating, the radio frequency power that is produced by the intentional radiator confirmed 20dB below that in the 100kHz bandwidth within the band that contains the highest level of the desired power, based on a radiated measurement.

### **20dBc was applied to the frequency over the limit of FCC 15.209 / Table 5 of RSS-Gen 7.2.5 (IC) and outside the restricted band of FCC15.205 / Table 3 of RSS-Gen 7.2.2 (IC).**

Frequency	Below 1GHz	Above 1GHz		20dBc
Instrument used	Test Receiver	Spectrum Analyzer		Spectrum Analyzer
Detector	QP	PK	AV	PK
IF Bandwidth	BW 120kHz	RBW: 1MHz VBW: 3MHz	RBW: 1MHz VBW: 10Hz *1)	RBW: 100kHz VBW: 300kHz
Test Distance	3m	3m (below 10GHz), 1m*2) (above 10GHz)		3m (below 10GHz), 1m*2) (above 10GHz)

\*1) Although 00-705 accepts VBW=10Hz for AV measurements, it was confirmed that superfluous smoothing was not performed.”

\*2) Distance Factor:  $20 \times \log(3.0\text{m}/1.0\text{m}) = 9.5\text{dB}$

The test was made on EUT at the normal use position.

The test results and limit are rounded off to one decimal place, so some differences might be observed.

**Measurement range** : 30M-26.5GHz  
**Test data** : APPENDIX  
**Test result** : Pass

**UL Japan, Inc.**

**Ise EMC Lab.**

4383-326 Asama-cho, Ise-shi, Mie-ken 516-0021 JAPAN

Telephone : +81 596 24 8999

Facsimile : +81 596 24 8124

## **SECTION 6: Antenna Terminal Conducted Tests**

### **Test Procedure**

The tests were made with below setting connected to the antenna port.

<b>Test</b>	<b>Span</b>	<b>RBW</b>	<b>VBW</b>	<b>Sweep time</b>	<b>Detector</b>	<b>Trace</b>	<b>Instrument used</b>
20dB Bandwidth	3MHz	30kHz	100kHz	Auto	Peak	Max Hold	Spectrum Analyzer
99% Occupied Bandwidth	Enough width to display 20dB Bandwidth	1 to 3% of Span	Three times of RBW	Auto	Peak	Max Hold *1)	Spectrum Analyzer
Maximum Peak Output Power	-	-	-	Auto	Peak	-	Power Meter (Sensor: 50MHz BW)
Carrier Frequency Separation	3MHz	30kHz	100kHz	Auto	Peak	Max Hold	Spectrum Analyzer
Number of Hopping Frequency	30MHz	300kHz	1MHz	Auto	Peak	Max Hold	Spectrum Analyzer
Dwell Time	Zero Span	100kHz, 1MHz	300kHz, 3MHz	As necessary capture the entire dwell time per hopping channel	Peak	Max Hold	Spectrum Analyzer
Conducted Spurious Emission *2)	9kHz to 150kHz	1kHz	3kHz	Auto	Peak	Max Hold	Spectrum Analyzer
	150kHz to 30MHz	10kHz	30kHz				
	30MHz to 25GHz (Less or equal to 5GHz)	100kHz	300kHz				
Conducted Spurious Emission Band Edge compliance	10MHz	100kHz	300kHz	Auto	Peak	Max Hold	Spectrum Analyzer

\*1) The measurement was performed with Max Hold since the duty cycle was not 100%.  
\*2) In the frequency range below 30MHz, RBW was narrowed to separate the noise contents. Then, wide-band noise near the limit was checked separately, however the noise was not detected as shown in the chart. (9kHz-150kHz:RBW=200Hz, 150kHz-30MHz:RBW=9.1kHz)

The test results and limit are rounded off to two decimals place, so some differences might be observed.

**Test data** : APPENDIX  
**Test result** : Pass

**APPENDIX 1: Data of EMI test**

**20dB Bandwidth and Carrier Frequency Separation**

**Model No. NR-244UH**

Test place Ise EMC Lab. No.06 Measurement Room  
 Report No. 10184498H  
 Date 01/15/2014  
 Temperature/ Humidity 21 deg. C / 31% RH  
 Engineer Masatoshi Nishiguchi  
 Mode Tx (Hopping on) DH5/3DH5/Inquiry

Mode	Freq. [MHz]	20dB Bandwidth [MHz]	Carrier Frequency Separation [MHz]	Limit for Carrier Frequency separation [MHz]
DH5	2402.0	0.949	1.000	≧ 0.633
DH5	2441.0	1.009	1.000	≧ 0.673
DH5	2480.0	0.983	1.000	≧ 0.655
3DH5	2402.0	1.241	1.000	≧ 0.827
3DH5	2441.0	1.265	1.000	≧ 0.843
3DH5	2480.0	1.269	1.000	≧ 0.846
Inquiry	2441.0	0.840	2.000	≧ 0.560

Limit: Two-thirds of 20dB Bandwidth or 25kHz (whichever is greater).  
 No limit applies to 20dB Bandwidth.

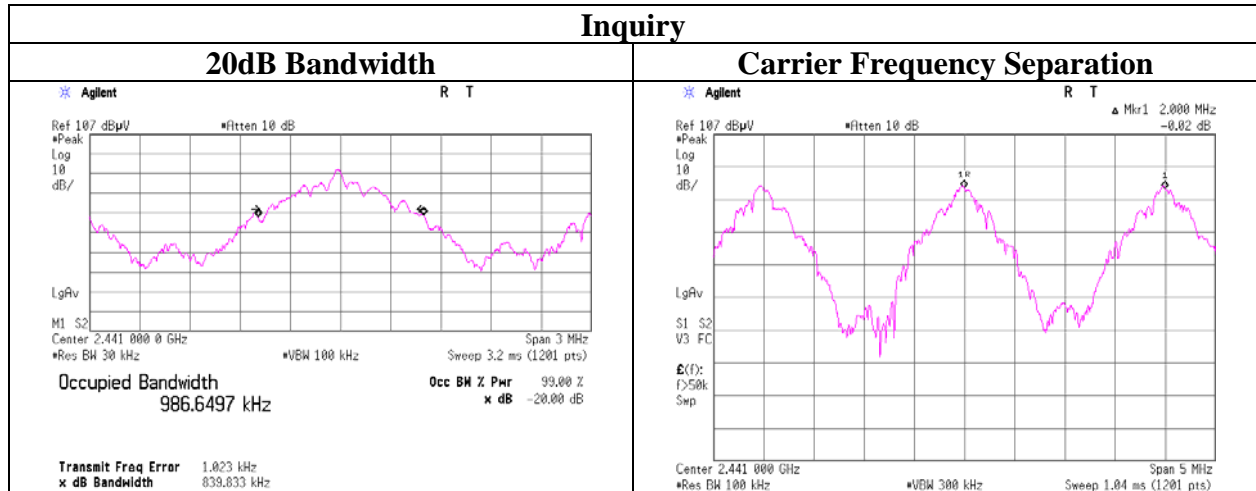

**UL Japan, Inc.**

**Ise EMC Lab.**

4383-326 Asama-cho, Ise-shi, Mie-ken 516-0021 JAPAN

Telephone : +81 596 24 8999

Facsimile : +81 596 24 8124

**20dB Bandwidth and Carrier Frequency Separation**  
**Model No. NR-244UH**

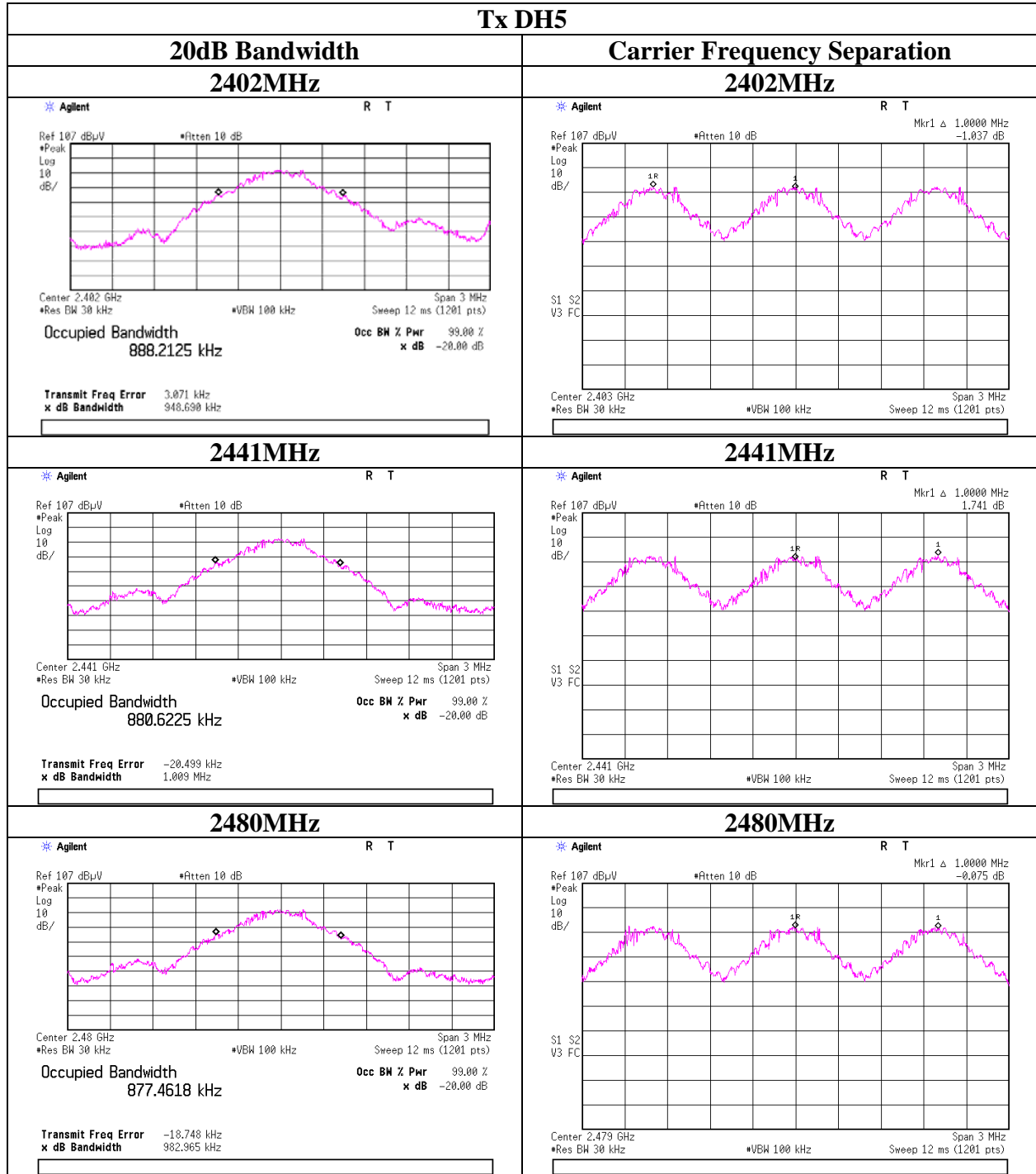

**20dB Bandwidth and Carrier Frequency Separation**  
**Model No. NR-244UH**

**Tx 3DH5**

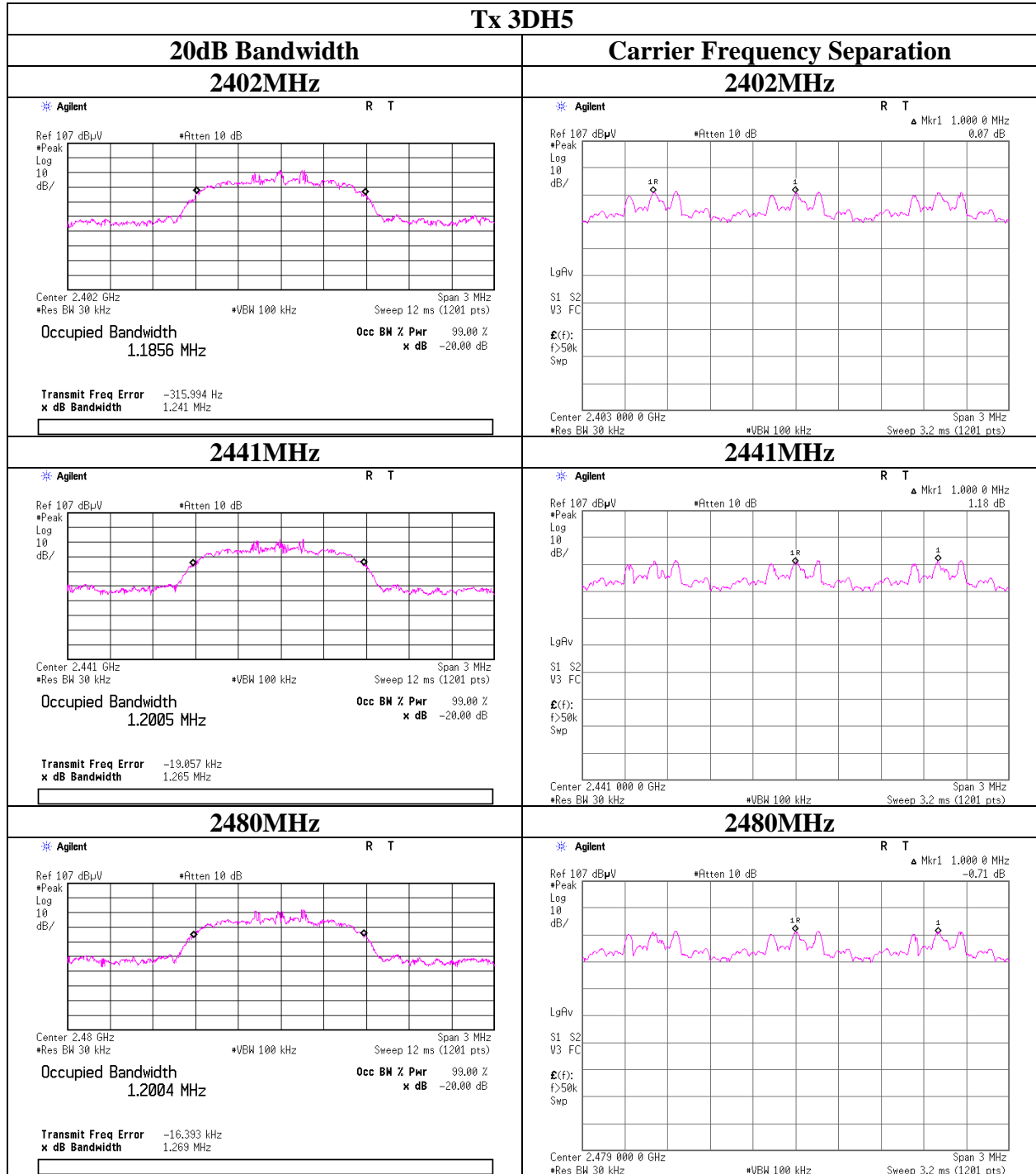

**UL Japan, Inc.**  
**Ise EMC Lab.**

4383-326 Asama-cho, Ise-shi, Mie-ken 516-0021 JAPAN  
 Telephone : +81 596 24 8999  
 Facsimile : +81 596 24 8124

## Number of Hopping Frequency

### Model No. NR-244UH

Test place	Ise EMC Lab. No.06 Measurement Room
Report No.	10184498H
Date	01/15/2014
Temperature/ Humidity	21 deg. C / 31% RH
Engineer	Masatoshi Nishiguchi
Mode	Tx (Hopping on) DH5/3DH5/Inquiry

Mode	Number of channel [times]	Limit [times]
DH5	79	>= 15
3DH5	79	>= 15
Inquiry	32	>= 15

Test was not performed at AFH mode whose number of hopping channel is 20 channels because this Bluetooth radio is in compliance of Bluetooth Specification.

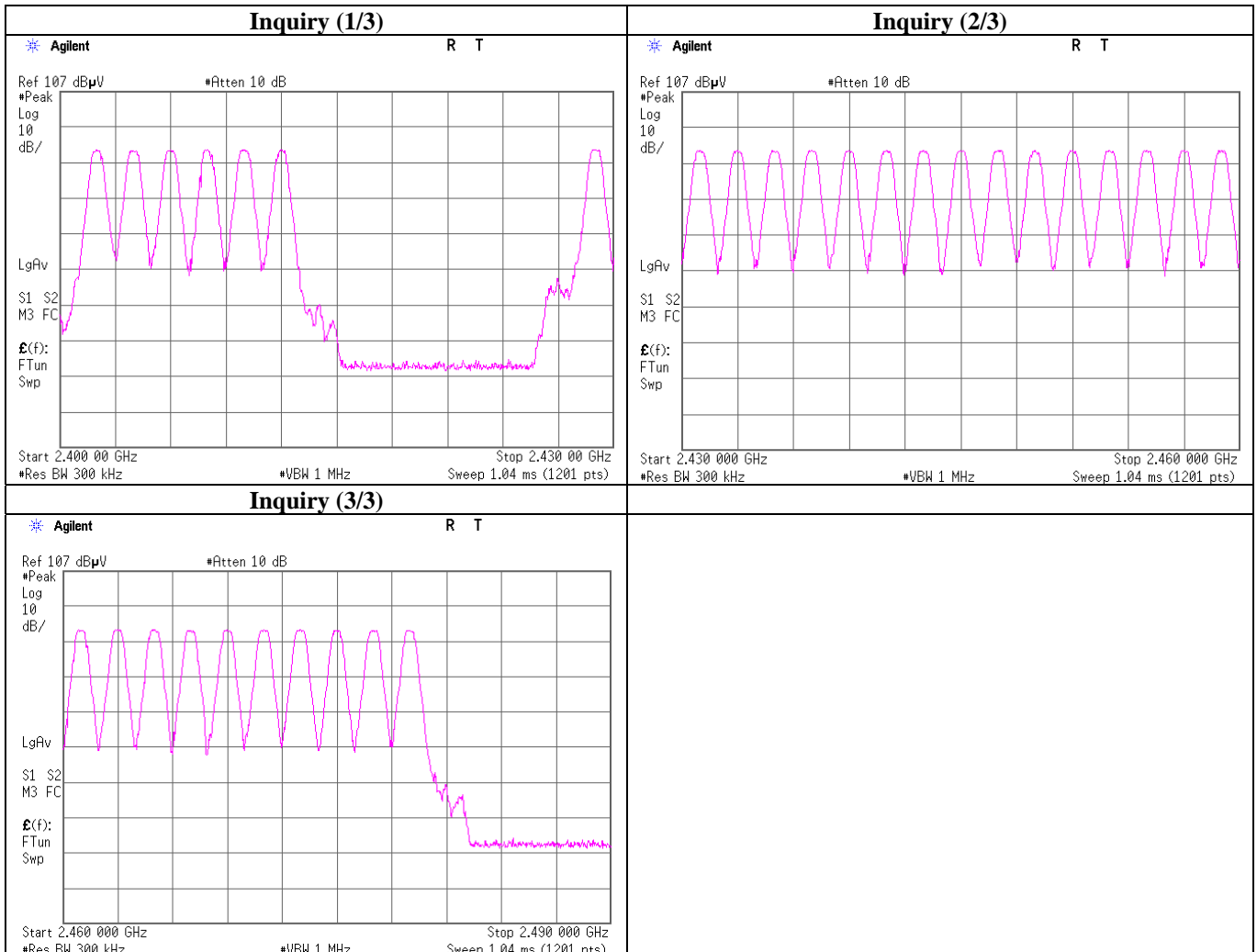

**UL Japan, Inc.**  
**Ise EMC Lab.**

4383-326 Asama-cho, Ise-shi, Mie-ken 516-0021 JAPAN  
 Telephone : +81 596 24 8999  
 Facsimile : +81 596 24 8124



**Number of Hopping Frequency**  
**Model No. NR-244UH**

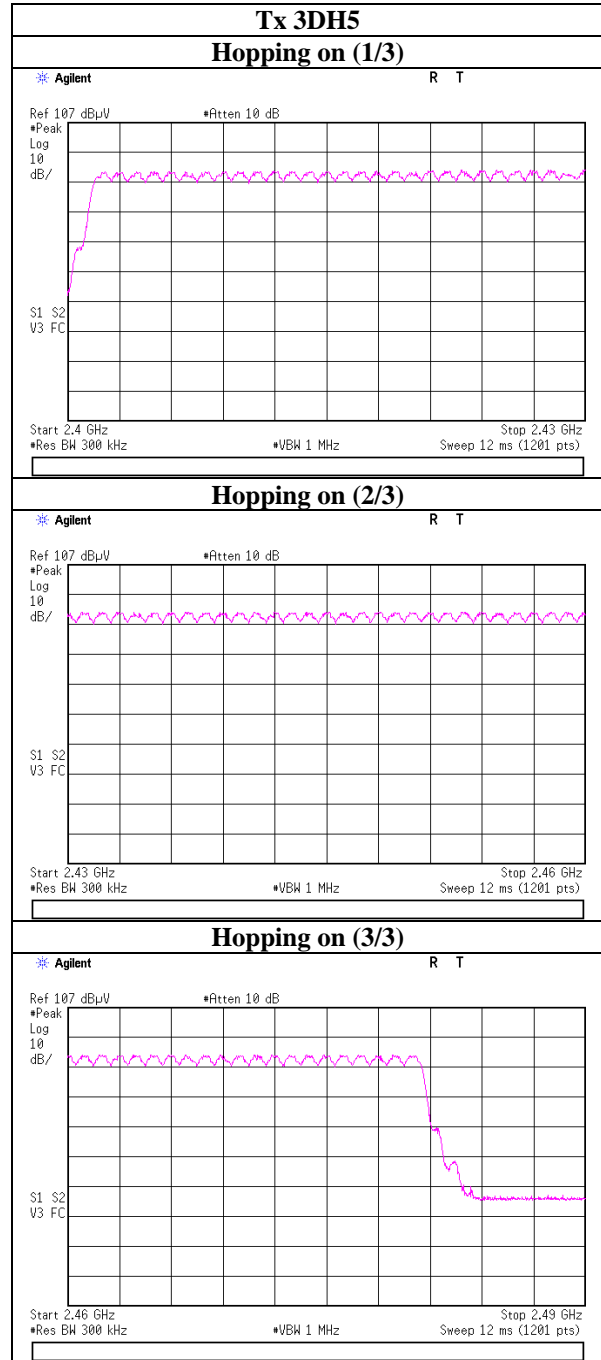
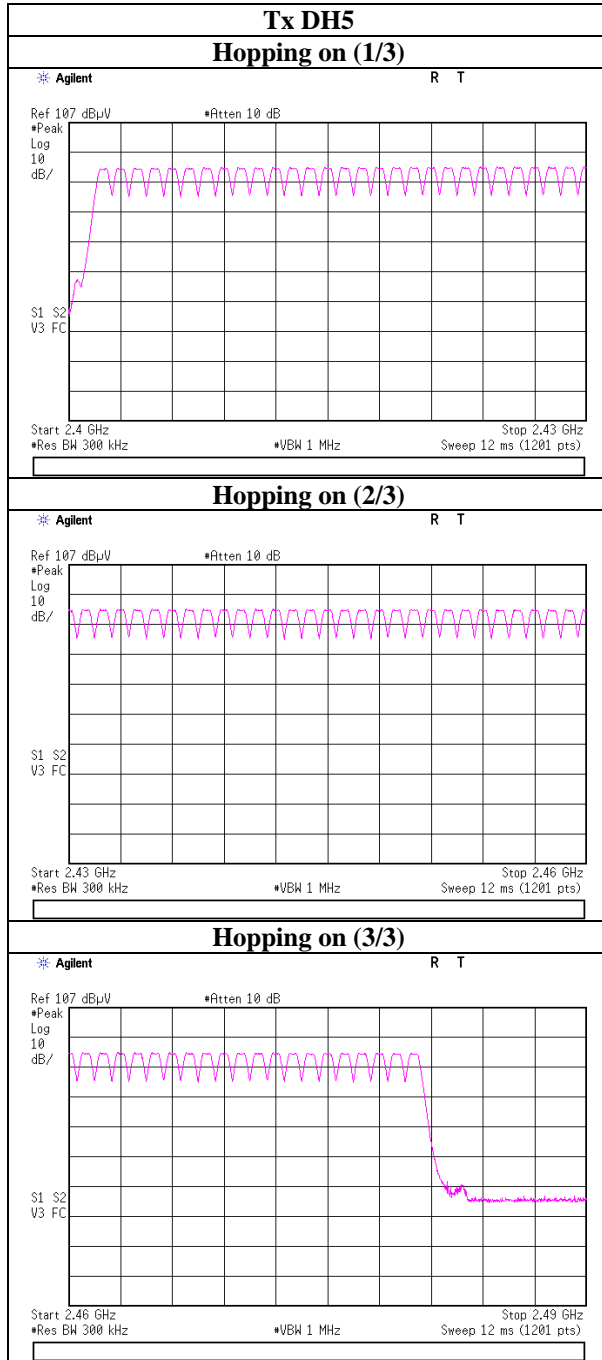

### Dwell time

#### Model No. NR-244UH

Test place	Ise EMC Lab. No.07 Measurement Room
Report No.	10184498H
Date	01/16/2014
Temperature/ Humidity	21 deg. C / 31% RH
Engineer	Masatoshi Nishiguchi
Mode	Tx (Hopping on) DH5/3DH5/Inquiry

Mode	Number of transmission in a 31.6(79 Hopping x 0.4) / 12.8(32 Hopping x 0.4)second period	Length of transmission time [msec]	Result [msec]	Limit [msec]
DH1	51.0 times / 5 sec. x 31.6 sec. = 323 times	0.410	132	400
DH3	25.0 times / 5 sec. x 31.6 sec. = 158 times	1.667	263	400
DH5	17.0 times / 5 sec. x 31.6 sec. = 108 times	2.947	318	400
3DH1	50.0 times / 5 sec. x 31.6 sec. = 316 times	0.421	133	400
3DH3	25.0 times / 5 sec. x 31.6 sec. = 158 times	1.677	265	400
3DH5	17.0 times / 5 sec. x 31.6 sec. = 108 times	2.930	316	400
Inquiry	100.0 times / 1 sec. x 12.8 sec. = 1280 times	0.112	143	400

Sample Calculation

Result = Number of transmission x Length of transmission time

This device complies with the Bluetooth protocol for FHSS operation, employing a pseudo random channel selection and hopping rate to ensure that the occupancy time in  $N \times 0.4s$ , where  $N$  is the number of channels being used in the hopping sequence ( $20 \leq N \leq 79$ ), is always less than  $0.4s$  regardless of packet size. This is confirmed in the test report for  $N=79$ .

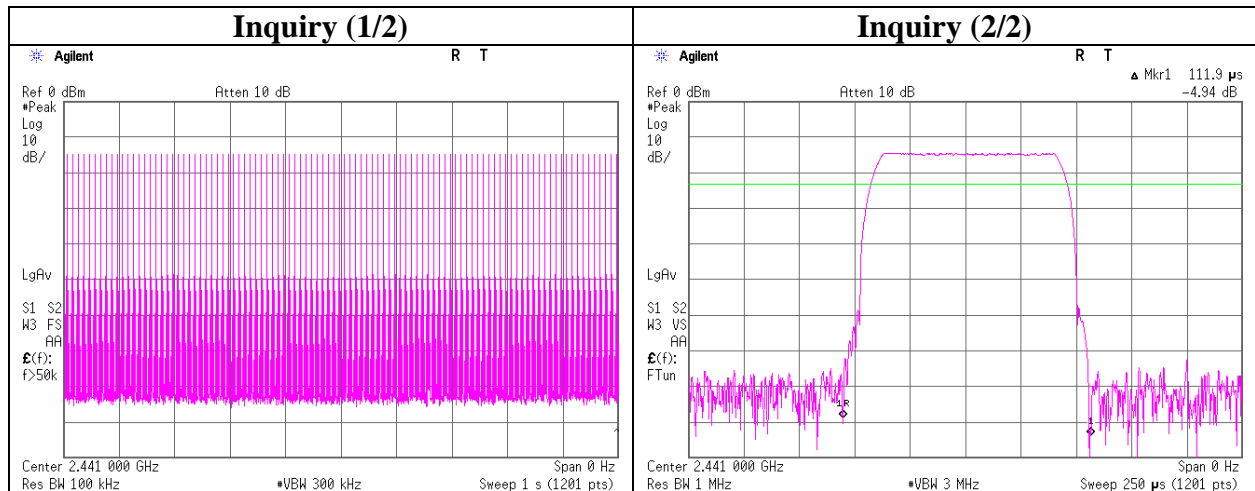

**UL Japan, Inc.**

**Ise EMC Lab.**

4383-326 Asama-cho, Ise-shi, Mie-ken 516-0021 JAPAN

Telephone : +81 596 24 8999

Facsimile : +81 596 24 8124

**Dwell time**  
**Model No. NR-244UH**

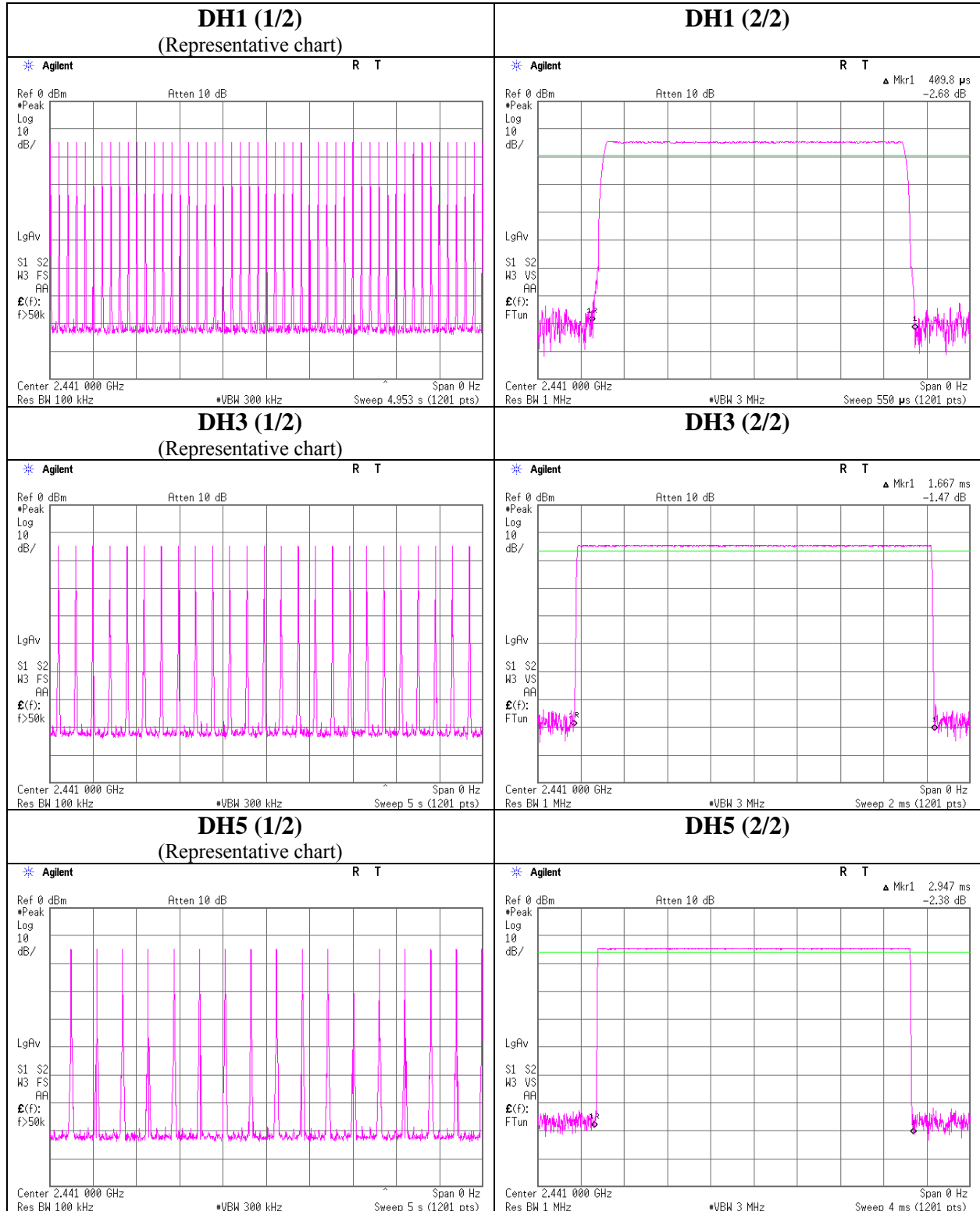

**UL Japan, Inc.**  
**Ise EMC Lab.**

4383-326 Asama-cho, Ise-shi, Mie-ken 516-0021 JAPAN  
 Telephone : +81 596 24 8999  
 Facsimile : +81 596 24 8124

**Dwell time**  
**Model No. NR-244UH**

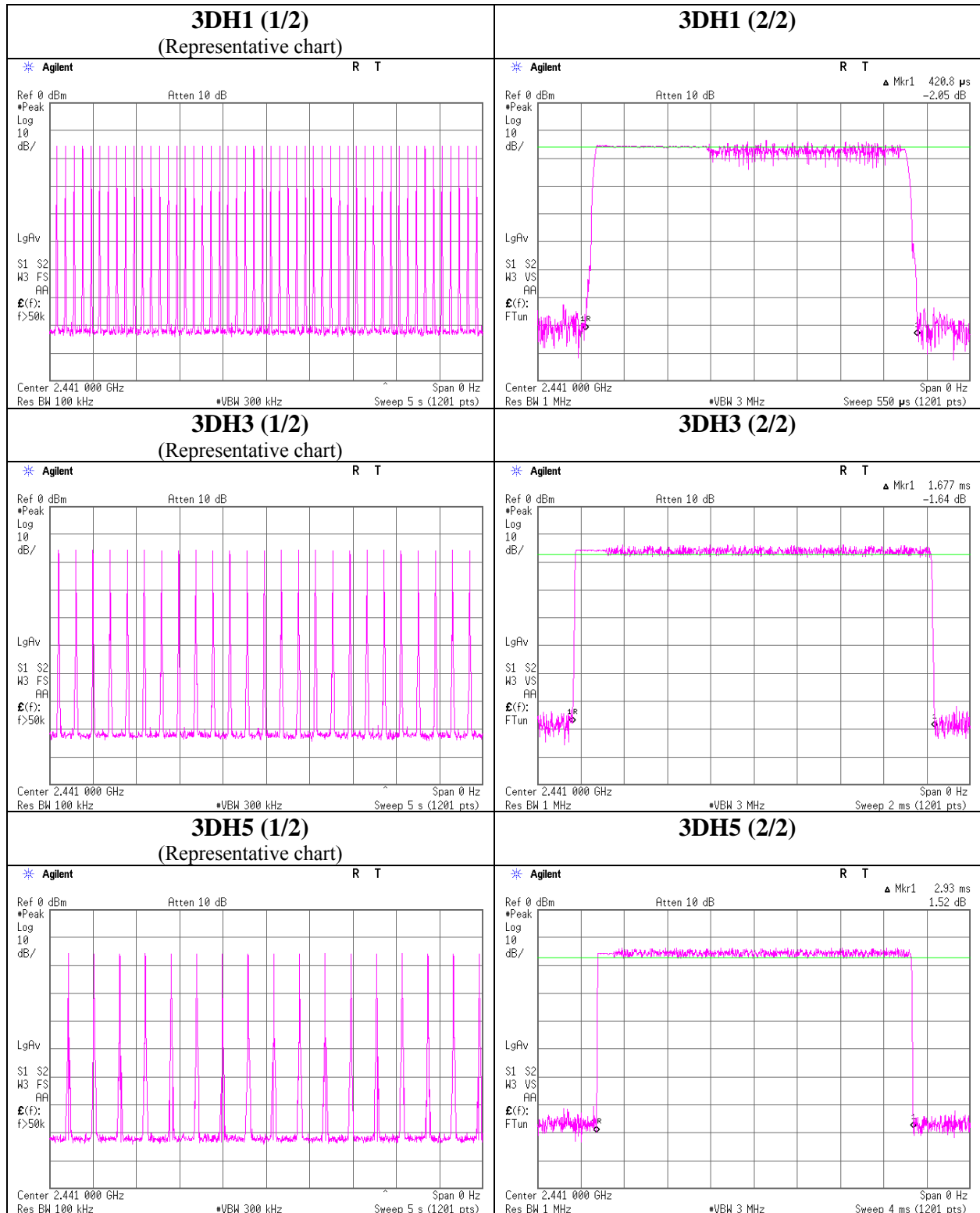

**UL Japan, Inc.**  
**Ise EMC Lab.**

4383-326 Asama-cho, Ise-shi, Mie-ken 516-0021 JAPAN  
 Telephone : +81 596 24 8999  
 Facsimile : +81 596 24 8124

## Maximum Peak Output Power

### Model No. NR-244UH

Test place	Ise EMC Lab. No.06 Measurement Room
Report No.	10184498H
Date	01/15/2014
Temperature/ Humidity	24 deg. C / 44% RH
Engineer	Masatoshi Nishiguchi
Mode	Tx (Hopping off) DH5/2DH5/3DH5/Inquiry

Mode	Freq. [MHz]	Reading [dBm]	Cable Loss [dB]	Atten. [dB]	Result		Limit		Margin [dB]
					[dBm]	[mW]	[dBm]	[mW]	
DH5	2402.0	-14.47	1.00	10.08	-3.39	0.46	20.96	125	24.35
DH5	2441.0	-14.18	1.00	10.08	-3.10	0.49	20.96	125	24.06
DH5	2480.0	-14.53	1.00	10.08	-3.45	0.45	20.96	125	24.41
2DH5	2402.0	-13.94	1.00	10.08	-2.86	0.52	20.96	125	23.82
2DH5	2441.0	-13.51	1.00	10.08	-2.43	0.57	20.96	125	23.39
2DH5	2480.0	-13.75	1.00	10.08	-2.67	0.54	20.96	125	23.63
3DH5	2402.0	-13.70	1.00	10.08	-2.62	0.55	20.96	125	23.58
3DH5	2441.0	-13.17	1.00	10.08	-2.09	0.62	20.96	125	23.05
3DH5	2480.0	-13.28	1.00	10.08	-2.20	0.60	20.96	125	23.16
Inquiry	2441.0	-14.28	1.00	10.08	-3.20	0.48	20.96	125	24.16

Sample Calculation:

Result = Reading + Cable Loss (including the cable(s) customer supplied)+ Attenuator

Test was not performed at AFH mode, because the decrease of number of channel (min: 20ch) at AFH mode does not influence on the output power and bandwidth of the EUT.  
 As this device had AFH mode and frequency separation could not meet the requirement of over 20dB BW without 2/3 relaxation, 125mW power limit was applied to it.

**UL Japan, Inc.**

**Ise EMC Lab.**

4383-326 Asama-cho, Ise-shi, Mie-ken 516-0021 JAPAN

Telephone : +81 596 24 8999

Facsimile : +81 596 24 8124

**Average Output Power(Reference data)**  
**Model No. NR-244UH**

Test place : Ise EMC Lab. No.06 Measurement Room  
Report No. : 10184498H  
Date : 01/15/2014  
Temperature/ Humidity : 24 deg. C / 44% RH  
Engineer : Masatoshi Nishiguchi  
Mode : Tx (Hopping off) DH5/2DH5/3DH5/Inquiry

Mode	Freq. [MHz]	Reading [dBm]	Cable Loss [dB]	Atten. [dB]	Result	
					[dBm]	[mW]
DH5	2402.0	-16.54	1.00	10.08	-5.46	0.28
DH5	2441.0	-16.19	1.00	10.08	-5.11	0.31
DH5	2480.0	-16.57	1.00	10.08	-5.49	0.28
2DH5	2402.0	-19.09	1.00	10.08	-8.01	0.16
2DH5	2441.0	-18.46	1.00	10.08	-7.38	0.18
2DH5	2480.0	-18.60	1.00	10.08	-7.52	0.18
3DH5	2402.0	-19.06	1.00	10.08	-7.98	0.16
3DH5	2441.0	-18.47	1.00	10.08	-7.39	0.18
3DH5	2480.0	-18.66	1.00	10.08	-7.58	0.17
Inquiry	2441.0	-23.66	1.00	10.08	-12.58	0.06

Sample Calculation:

Result = Reading + Cable Loss (including the cable(s) customer supplied)+ Attenuator

**UL Japan, Inc.**

**Ise EMC Lab.**

4383-326 Asama-cho, Ise-shi, Mie-ken 516-0021 JAPAN

Telephone : +81 596 24 8999

Facsimile : +81 596 24 8124

**Radiated Spurious Emission**  
**Model No. NR-244UH**

Test place : Ise EMC Lab. No.2 Semi Anechoic Chamber  
Report No. : 10184498H  
Date : 01/29/2014                      01/29/2014  
Temperature/ Humidity : 23 deg. C / 28% RH    23 deg. C / 28% RH  
Engineer : Satofumi Matsuyama    Tsubasa Takayama  
(Above 1GHz)                      (Below1GHz)  
Mode : Tx, DH5 2402MHz

Polarity	Frequency [MHz]	Detector	Reading [dBuV]	Ant.Fac. [dB/m]	Loss [dB]	Gain [dB]	Result [dBuV/m]	Limit [dBuV/m]	Margin [dB]	Remark
Hori	101.600	QP	32.1	10.3	7.5	28.4	21.5	43.5	22.0	
Hori	111.000	QP	32.2	11.6	7.6	28.4	23.0	43.5	20.5	
Hori	124.185	QP	26.4	13.2	7.7	28.3	19.0	43.5	24.5	
Hori	135.210	QP	37.1	14.1	7.7	28.3	30.6	43.5	12.9	
Hori	191.900	QP	28.3	16.4	8.1	27.9	24.9	43.5	18.6	
Hori	380.500	QP	33.2	16.7	9.2	28.2	30.9	46.0	15.1	
Hori	617.410	QP	26.5	19.7	10.2	28.8	27.6	46.0	18.4	
Hori	750.000	QP	28.2	21.0	10.7	28.4	31.5	46.0	14.5	
Hori	811.210	QP	25.6	21.8	10.9	28.2	30.1	46.0	15.9	
Hori	950.000	QP	24.3	22.8	11.4	27.6	30.9	46.0	15.1	
Hori	2390.000	PK	44.2	26.8	2.4	34.7	38.7	73.9	35.2	
Hori	4804.000	PK	NS	-	-	-	-	73.9	-	
Hori	7206.000	PK	NS	-	-	-	-	73.9	-	
Hori	9608.000	PK	NS	-	-	-	-	73.9	-	
Hori	2390.000	AV	31.9	26.8	2.4	34.7	26.4	53.9	27.5	
Hori	4804.000	AV	NS	-	-	-	-	53.9	-	
Hori	7206.000	AV	NS	-	-	-	-	53.9	-	
Hori	9608.000	AV	NS	-	-	-	-	53.9	-	
Vert	101.600	QP	36.1	10.3	7.5	28.5	25.4	43.5	18.1	
Vert	111.000	QP	35.5	11.6	7.6	28.4	26.3	43.5	17.2	
Vert	124.185	QP	35.5	13.2	7.7	28.3	28.1	43.5	15.4	
Vert	135.210	QP	31.4	14.1	7.7	28.3	24.9	43.5	18.6	
Vert	191.900	QP	33.7	16.4	8.1	27.9	30.3	43.5	13.2	
Vert	380.500	QP	29.3	16.7	9.2	28.2	27.0	46.0	19.0	
Vert	617.410	QP	29.2	19.7	10.2	28.8	30.3	46.0	15.7	
Vert	750.000	QP	27.2	21.0	10.7	28.4	30.5	46.0	15.5	
Vert	811.210	QP	27.4	21.8	10.9	28.2	31.9	46.0	14.1	
Vert	7206.000	PK	NS	-	-	-	-	73.9	-	
Vert	9608.000	PK	NS	-	-	-	-	73.9	-	
Vert	2390.000	AV	31.9	26.8	2.4	34.7	26.4	53.9	27.5	
Vert	4804.000	AV	NS	-	-	-	-	53.9	-	
Vert	7206.000	AV	NS	-	-	-	-	53.9	-	
Vert	9608.000	AV	NS	-	-	-	-	53.9	-	

Result = Reading + Ant Factor + Loss (Cable+Attenuator+Filter-Distance factor(above 10GHz)) - Gain(Amplifier)

\*Other frequency noises omitted in this report were not seen or had enough margin (more than 20dB).

\*The 10th harmonic was not seen so the result was its base noise level.  
Distance factor:      10GHz-26.5GHz    20log(3.0m/1.0m)= 9.5dB

**20dBc Data Sheet**

Polarity	Frequency [MHz]	Detector	Reading [dBuV]	Ant Factor [dB/m]	Loss [dB]	Gain [dB]	Result [dBuV/m]	Limit [dBuV/m]	Margin [dB]	Remark
Hori	2402.000	PK	94.3	26.8	2.4	34.7	88.8	-	-	Carrier
Hori	2400.000	PK	46.6	26.8	2.4	34.7	41.1	68.8	27.7	
Vert	2402.000	PK	91.3	26.8	2.4	34.7	85.8	-	-	Carrier
Vert	2400.000	PK	44.0	26.8	2.4	34.7	38.5	65.8	27.3	

Result = Reading + Ant Factor + Loss (Cable+Attenuator+Filter-Distance factor(above 10GHz)) - Gain(Amplifier)

## Radiated Spurious Emission

### Model No. NR-244UH

Test place Ise EMC Lab. No.2 Semi Anechoic Chamber  
Report No. 10184498H  
Date 01/29/2014  
Temperature/ Humidity 23 deg. C / 28% RH 23 deg. C / 28% RH  
Engineer Satofumi Matsuyama Tsubasa Takayama  
(Above 1GHz) (Below 1GHz)  
Mode Tx, DH5 2441MHz

Polarity	Frequency [MHz]	Detector	Reading [dBuV]	Ant.Fac. [dB/m]	Loss [dB]	Gain [dB]	Result [dBuV/m]	Limit [dBuV/m]	Margin [dB]	Remark
Hori	101.600	QP	32.0	10.3	7.5	28.5	21.3	43.5	22.2	
Hori	111.000	QP	32.0	11.6	7.6	28.4	22.8	43.5	20.7	
Hori	124.185	QP	26.0	13.2	7.7	28.3	18.6	43.5	24.9	
Hori	135.210	QP	37.4	14.1	7.7	28.3	30.9	43.5	12.6	
Hori	191.900	QP	28.2	16.4	8.1	27.9	24.8	43.5	18.7	
Hori	387.995	QP	33.6	16.9	9.3	28.2	31.6	46.0	14.4	
Hori	617.410	QP	26.5	19.7	10.2	28.8	27.6	46.0	18.4	
Hori	750.000	QP	28.0	21.0	10.7	28.4	31.3	46.0	14.7	
Hori	811.220	QP	25.8	21.8	10.9	28.2	30.3	46.0	15.7	
Hori	950.000	QP	24.2	22.8	11.4	27.6	30.8	46.0	15.2	
Hori	4882.000	PK	NS	-	-	-	-	73.9	-	
Hori	7323.000	PK	NS	-	-	-	-	73.9	-	
Hori	9764.000	PK	NS	-	-	-	-	73.9	-	
Hori	4882.000	AV	NS	-	-	-	-	53.9	-	
Hori	7323.000	AV	NS	-	-	-	-	53.9	-	
Hori	9764.000	AV	NS	-	-	-	-	53.9	-	
Vert	101.600	QP	36.3	10.3	7.5	28.5	25.6	43.5	17.9	
Vert	111.000	QP	35.4	11.6	7.6	28.4	26.2	43.5	17.3	
Vert	124.185	QP	35.1	13.2	7.7	28.3	27.7	43.5	15.8	
Vert	135.210	QP	32.0	14.1	7.7	28.3	25.5	43.5	18.0	
Vert	191.900	QP	34.1	16.4	8.1	27.9	30.7	43.5	12.8	
Vert	617.410	QP	29.3	19.7	10.2	28.8	30.4	46.0	15.6	
Vert	750.000	QP	27.1	21.0	10.7	28.4	30.4	46.0	15.6	
Vert	811.220	QP	27.0	21.8	10.9	28.2	31.5	46.0	14.5	
Vert	950.000	QP	26.6	22.8	11.4	27.6	33.2	46.0	12.8	
Vert	4882.000	PK	NS	-	-	-	-	73.9	-	
Vert	7323.000	PK	NS	-	-	-	-	73.9	-	
Vert	9764.000	PK	NS	-	-	-	-	73.9	-	
Vert	4882.000	AV	NS	-	-	-	-	53.9	-	
Vert	7323.000	AV	NS	-	-	-	-	53.9	-	
Vert	9764.000	AV	NS	-	-	-	-	53.9	-	

Result = Reading + Ant Factor + Loss (Cable+Attenuator+Filter-Distance factor(above 10GHz)) - Gain(Amplifier)

\*Other frequency noises omitted in this report were not seen or had enough margin (more than 20dB).

\*The 10th harmonic was not seen so the result was its base noise level.  
Distance factor: 10GHz-26.5GHz 20log(3.0m/1.0m)= 9.5dB

**UL Japan, Inc.**

**Ise EMC Lab.**

4383-326 Asama-cho, Ise-shi, Mie-ken 516-0021 JAPAN

Telephone : +81 596 24 8999

Facsimile : +81 596 24 8124



## Radiated Spurious Emission

### Model No. NR-244UH

Test place	Ise EMC Lab. No.2 Semi Anechoic Chamber	
Report No.	10184498H	
Date	01/29/2014	01/29/2014
Temperature/ Humidity	23 deg. C / 28% RH	23 deg. C / 28% RH
Engineer	Satofumi Matsuyama (Above 1GHz)	Tsubasa Takayama (Below 1GHz)
Mode	Tx, DH5 2480MHz	

Polarity	Frequency [MHz]	Detector	Reading [dBuV]	Ant.Fac. [dB/m]	Loss [dB]	Gain [dB]	Result [dBuV/m]	Limit [dBuV/m]	Margin [dB]	Remark
Hori	101.600	QP	32.3	10.3	7.5	28.5	21.6	43.5	21.9	
Hori	111.000	QP	32.4	11.6	7.6	28.4	23.2	43.5	20.3	
Hori	124.185	QP	27.9	13.2	7.7	28.3	20.5	43.5	23.0	
Hori	135.210	QP	37.3	14.1	7.7	28.3	30.8	43.5	12.7	
Hori	191.900	QP	28.3	16.4	8.1	27.9	24.9	43.5	18.6	
Hori	379.634	QP	32.4	16.7	9.2	28.2	30.1	46.0	15.9	
Hori	617.410	QP	26.3	19.7	10.2	28.8	27.4	46.0	18.6	
Hori	750.000	QP	28.3	21.0	10.7	28.4	31.6	46.0	14.4	
Hori	811.210	QP	25.3	21.8	10.9	28.2	29.8	46.0	16.2	
Hori	950.000	QP	24.7	22.8	11.4	27.6	31.3	46.0	14.7	
Hori	2483.500	PK	44.5	26.7	2.5	34.7	39.0	73.9	34.9	
Hori	4960.000	PK	NS	-	-	-	-	73.9	-	
Hori	7440.000	PK	NS	-	-	-	-	73.9	-	
Hori	9920.000	PK	NS	-	-	-	-	73.9	-	
Hori	2483.500	AV	32.3	26.7	2.5	34.7	26.8	53.9	27.1	
Hori	4960.000	AV	NS	-	-	-	-	53.9	-	
Hori	7440.000	AV	NS	-	-	-	-	53.9	-	
Hori	9920.000	AV	NS	-	-	-	-	53.9	-	
Vert	101.600	QP	36.7	10.3	7.5	28.5	26.0	43.5	17.5	
Vert	111.000	QP	35.4	11.6	7.6	28.4	26.2	43.5	17.3	
Vert	124.185	QP	35.5	13.2	7.7	28.3	28.1	43.5	15.4	
Vert	135.210	QP	32.2	14.1	7.7	28.3	25.7	43.5	17.8	
Vert	191.900	QP	34.3	16.4	8.1	27.9	30.9	43.5	12.6	
Vert	617.410	QP	29.4	19.7	10.2	28.8	30.5	46.0	15.5	
Vert	750.000	QP	27.5	21.0	10.7	28.4	30.8	46.0	15.2	
Vert	811.210	QP	26.8	21.8	10.9	28.2	31.3	46.0	14.7	
Vert	950.000	QP	26.6	22.8	11.4	27.6	33.2	46.0	12.8	
Vert	2483.500	PK	44.4	26.7	2.5	34.7	38.9	73.9	35.0	
Vert	4960.000	PK	NS	-	-	-	-	73.9	-	
Vert	7440.000	PK	NS	-	-	-	-	73.9	-	
Vert	9920.000	PK	NS	-	-	-	-	73.9	-	
Vert	2483.500	AV	31.9	26.7	2.5	34.7	26.4	53.9	27.5	
Vert	4960.000	AV	NS	-	-	-	-	53.9	-	
Vert	7440.000	AV	NS	-	-	-	-	53.9	-	
Vert	9920.000	AV	NS	-	-	-	-	53.9	-	

Result = Reading + Ant Factor + Loss (Cable+Attenuator+Filter-Distance factor(above 10GHz)) - Gain(Amplifier)

\*Other frequency noises omitted in this report were not seen or had enough margin (more than 20dB).

\*The 10th harmonic was not seen so the result was its base noise level.

Distance factor: 10GHz-26.5GHz 20log(3.0m/1.0m)= 9.5dB

**UL Japan, Inc.**

**Ise EMC Lab.**

4383-326 Asama-cho, Ise-shi, Mie-ken 516-0021 JAPAN

Telephone : +81 596 24 8999

Facsimile : +81 596 24 8124

## Radiated Spurious Emission

### Model No. NR-244UH

Test place Ise EMC Lab. No.2 Semi Anechoic Chamber  
Report No. 10184498H  
Date 01/29/2014  
Temperature/ Humidity 23 deg. C / 28% RH 23 deg. C / 28% RH  
Engineer Satofumi Matsuyama Tsubasa Takayama  
(Above 1GHz) (Below 1GHz)  
Mode Tx, 3DH5 2402MHz

Polarity	Frequency [MHz]	Detector	Reading [dBuV]	Ant.Fac. [dB/m]	Loss [dB]	Gain [dB]	Result [dBuV/m]	Limit [dBuV/m]	Margin [dB]	Remark
Hori	101.600	QP	32.6	10.3	7.5	28.5	21.9	43.5	21.6	
Hori	111.000	QP	32.9	11.6	7.6	28.4	23.7	43.5	19.8	
Hori	124.185	QP	28.4	13.2	7.7	28.3	21.0	43.5	22.5	
Hori	135.210	QP	37.4	14.1	7.7	28.3	30.9	43.5	12.6	
Hori	191.900	QP	27.1	16.4	8.1	27.9	23.7	43.5	19.8	
Hori	381.707	QP	33.2	16.8	9.2	28.2	31.0	46.0	15.0	
Hori	617.410	QP	26.0	19.7	10.2	28.8	27.1	46.0	18.9	
Hori	750.000	QP	26.8	21.0	10.7	28.4	30.1	46.0	15.9	
Hori	800.000	QP	23.1	21.8	10.9	28.2	27.6	46.0	18.4	
Hori	811.210	QP	24.9	21.8	10.9	28.2	29.4	46.0	16.6	
Hori	950.000	QP	24.5	22.8	11.4	27.6	31.1	46.0	14.9	
Hori	2390.000	PK	44.9	26.8	2.4	34.7	39.4	73.9	34.5	
Hori	4804.000	PK	NS	-	-	-	-	73.9	-	
Hori	7206.000	PK	NS	-	-	-	-	73.9	-	
Hori	9608.000	PK	NS	-	-	-	-	73.9	-	
Hori	2390.000	AV	31.9	26.8	2.4	34.7	26.4	53.9	27.5	
Hori	4804.000	AV	NS	-	-	-	-	53.9	-	
Hori	7206.000	AV	NS	-	-	-	-	53.9	-	
Hori	9608.000	AV	NS	-	-	-	-	53.9	-	
Vert	101.600	QP	36.4	10.3	7.5	28.5	25.7	43.5	17.8	
Vert	111.000	QP	35.6	11.6	7.6	28.4	26.4	43.5	17.1	
Vert	124.185	QP	36.7	13.2	7.7	28.3	29.3	43.5	14.2	
Vert	135.210	QP	31.0	14.1	7.7	28.3	24.5	43.5	19.0	
Vert	191.900	QP	33.9	16.4	8.1	27.9	30.5	43.5	13.0	
Vert	384.839	QP	28.1	16.9	9.2	28.2	26.0	46.0	20.0	
Vert	617.410	QP	28.4	19.7	10.2	28.8	29.5	46.0	16.5	
Vert	750.000	QP	28.0	21.0	10.7	28.4	31.3	46.0	14.7	
Vert	2390.000	PK	45.0	26.8	2.4	34.7	39.5	73.9	34.4	
Vert	4804.000	PK	NS	-	-	-	-	73.9	-	
Vert	7206.000	PK	NS	-	-	-	-	73.9	-	
Vert	9608.000	PK	NS	-	-	-	-	73.9	-	
Vert	2390.000	AV	31.9	26.8	2.4	34.7	26.4	53.9	27.5	
Vert	4804.000	AV	NS	-	-	-	-	53.9	-	
Vert	7206.000	AV	NS	-	-	-	-	53.9	-	
Vert	9608.000	AV	NS	-	-	-	-	53.9	-	

Result = Reading + Ant Factor + Loss (Cable+Attenuator+Filter-Distance factor(above 10GHz)) - Gain(Amplifier)

\*Other frequency noises omitted in this report were not seen or had enough margin (more than 20dB).

\*The 10th harmonic was not seen so the result was its base noise level.  
Distance factor: 10GHz-26.5GHz 20log(3.0m/1.0m)= 9.5dB

#### 20dBc Data Sheet

Polarity	Frequency [MHz]	Detector	Reading [dBuV]	Ant Factor [dB/m]	Loss [dB]	Gain [dB]	Result [dBuV/m]	Limit [dBuV/m]	Margin [dB]	Remark
Hori	2402.000	PK	92.9	26.8	2.4	34.7	87.4	-	-	Carrier
Hori	2400.000	PK	46.8	26.8	2.4	34.7	41.3	67.4	26.1	
Vert	2402.000	PK	89.9	26.8	2.4	34.7	84.4	-	-	Carrier
Vert	2400.000	PK	44.2	26.8	2.4	34.7	38.7	64.4	25.7	

Result = Reading + Ant Factor + Loss (Cable+Attenuator+Filter-Distance factor(above 10GHz)) - Gain(Amplifier)

## Radiated Spurious Emission

### Model No. NR-244UH

Test place Ise EMC Lab. No.2 Semi Anechoic Chamber  
Report No. 10184498H  
Date 01/29/2014 01/29/2014  
Temperature/ Humidity 23 deg. C / 28% RH 23 deg. C / 28% RH  
Engineer Satofumi Matsuyama Tsubasa Takayama  
(Above 1GHz) (Below 1GHz)  
Mode Tx, 3DH5 2441MHz

Polarity	Frequency [MHz]	Detector	Reading [dBuV]	Ant.Fac. [dB/m]	Loss [dB]	Gain [dB]	Result [dBuV/m]	Limit [dBuV/m]	Margin [dB]	Remark
Hori	101.600	QP	32.1	10.3	7.5	28.5	21.4	43.5	22.1	
Hori	111.000	QP	32.4	11.6	7.6	28.4	23.2	43.5	20.3	
Hori	124.185	QP	28.1	13.2	7.7	28.3	20.7	43.5	22.8	
Hori	135.210	QP	37.0	14.1	7.7	28.3	30.5	43.5	13.0	
Hori	191.900	QP	27.1	16.4	8.1	27.9	23.7	43.5	19.8	
Hori	384.839	QP	33.8	16.9	9.2	28.2	31.7	46.0	14.3	
Hori	617.410	QP	26.1	19.7	10.2	28.8	27.2	46.0	18.8	
Hori	750.000	QP	26.9	21.0	10.7	28.4	30.2	46.0	15.8	
Hori	811.210	QP	25.1	21.8	10.9	28.2	29.6	46.0	16.4	
Hori	950.000	QP	24.3	22.8	11.4	27.6	30.9	46.0	15.1	
Hori	4882.000	PK	NS	-	-	-	-	73.9	-	
Hori	7323.000	PK	NS	-	-	-	-	73.9	-	
Hori	9764.000	PK	NS	-	-	-	-	73.9	-	
Hori	4882.000	AV	NS	-	-	-	-	53.9	-	
Hori	7323.000	AV	NS	-	-	-	-	53.9	-	
Hori	9764.000	AV	NS	-	-	-	-	53.9	-	
Vert	101.600	QP	36.0	10.3	7.5	28.5	25.3	43.5	18.2	
Vert	111.000	QP	35.2	11.6	7.6	28.4	26.0	43.5	17.5	
Vert	124.185	QP	36.4	13.2	7.7	28.3	29.0	43.5	14.5	
Vert	135.210	QP	30.3	14.1	7.7	28.3	23.8	43.5	19.7	
Vert	191.900	QP	33.7	16.4	8.1	27.9	30.3	43.5	13.2	
Vert	617.410	QP	28.1	19.7	10.2	28.8	29.2	46.0	16.8	
Vert	750.000	QP	28.3	21.0	10.7	28.4	31.6	46.0	14.4	
Vert	811.210	QP	26.6	21.8	10.9	28.2	31.1	46.0	14.9	
Vert	950.000	QP	26.3	22.8	11.4	27.6	32.9	46.0	13.1	
Vert	4882.000	PK	NS	-	-	-	-	73.9	-	
Vert	7323.000	PK	NS	-	-	-	-	73.9	-	
Vert	9764.000	PK	NS	-	-	-	-	73.9	-	
Vert	4882.000	AV	NS	-	-	-	-	53.9	-	
Vert	7323.000	AV	NS	-	-	-	-	53.9	-	
Vert	9764.000	AV	NS	-	-	-	-	53.9	-	

Result = Reading + Ant Factor + Loss (Cable+Attenuator+Filter-Distance factor(above 10GHz)) - Gain(Amplifier)

\*Other frequency noises omitted in this report were not seen or had enough margin (more than 20dB).

\*The 10th harmonic was not seen so the result was its base noise level.

Distance factor: 10GHz-26.5GHz 20log(3.0m/1.0m)= 9.5dB

**UL Japan, Inc.**

**Ise EMC Lab.**

4383-326 Asama-cho, Ise-shi, Mie-ken 516-0021 JAPAN

Telephone : +81 596 24 8999

Facsimile : +81 596 24 8124

## Radiated Spurious Emission

### Model No. NR-244UH

Test place	Ise EMC Lab. No.2 Semi Anechoic Chamber		
Report No.	10184498H		
Date	01/29/2014	01/29/2014	
Temperature/ Humidity	23 deg. C / 28% RH	23 deg. C / 28% RH	
Engineer	Satofumi Matsuyama (Above 1GHz)	Tsubasa Takayama (Below 1GHz)	
Mode	Tx, 3DH5 2480MHz		

Polarity	Frequency [MHz]	Detector	Reading [dBuV]	Ant.Fac. [dB/m]	Loss [dB]	Gain [dB]	Result [dBuV/m]	Limit [dBuV/m]	Margin [dB]	Remark
Hori	101.600	QP	32.0	10.3	7.5	28.5	21.3	43.5	22.2	
Hori	111.000	QP	32.1	11.6	7.6	28.4	22.9	43.5	20.6	
Hori	124.185	QP	27.9	13.2	7.7	28.3	20.5	43.5	23.0	
Hori	135.210	QP	36.9	14.1	7.7	28.3	30.4	43.5	13.1	
Hori	191.900	QP	27.3	16.4	8.1	27.9	23.9	43.5	19.6	
Hori	379.748	QP	33.3	16.7	9.2	28.2	31.0	46.0	15.0	
Hori	617.410	QP	26.0	19.7	10.2	28.8	27.1	46.0	18.9	
Hori	750.000	QP	28.4	21.0	10.7	28.4	31.7	46.0	14.3	
Hori	811.210	QP	25.1	21.8	10.9	28.2	29.6	46.0	16.4	
Hori	950.000	QP	25.0	22.8	11.4	27.6	31.6	46.0	14.4	
Hori	2483.500	PK	45.5	26.7	2.5	34.7	40.0	73.9	33.9	
Hori	4960.000	PK	NS	-	-	-	-	73.9	-	
Hori	7440.000	PK	NS	-	-	-	-	73.9	-	
Hori	9920.000	PK	NS	-	-	-	-	73.9	-	
Hori	2483.500	AV	32.8	26.7	2.5	34.7	27.3	53.9	26.6	
Hori	4960.000	AV	NS	-	-	-	-	53.9	-	
Hori	7440.000	AV	NS	-	-	-	-	53.9	-	
Hori	9920.000	AV	NS	-	-	-	-	53.9	-	
Vert	101.600	QP	35.8	10.3	7.5	28.5	25.1	43.5	18.4	
Vert	111.000	QP	35.7	11.6	7.6	28.4	26.5	43.5	17.0	
Vert	124.185	QP	36.0	13.2	7.7	28.3	28.6	43.5	14.9	
Vert	135.210	QP	32.6	14.1	7.7	28.3	26.1	43.5	17.4	
Vert	191.900	QP	34.0	16.4	8.1	27.9	30.6	43.5	12.9	
Vert	617.410	QP	28.5	19.7	10.2	28.8	29.6	46.0	16.4	
Vert	750.000	QP	28.0	21.0	10.7	28.4	31.3	46.0	14.7	
Vert	811.210	QP	26.8	21.8	10.9	28.2	31.3	46.0	14.7	
Vert	950.000	QP	26.5	22.8	11.4	27.6	33.1	46.0	12.9	
Vert	2483.500	PK	44.3	26.7	2.5	34.7	38.8	73.9	35.1	
Vert	4960.000	PK	NS	-	-	-	-	73.9	-	
Vert	7440.000	PK	NS	-	-	-	-	73.9	-	
Vert	9920.000	PK	NS	-	-	-	-	73.9	-	
Vert	2483.500	AV	32.1	26.7	2.5	34.7	26.6	53.9	27.3	
Vert	4960.000	AV	NS	-	-	-	-	53.9	-	
Vert	7440.000	AV	NS	-	-	-	-	53.9	-	
Vert	9920.000	AV	NS	-	-	-	-	53.9	-	

Result = Reading + Ant Factor + Loss (Cable+Attenuator+Filter-Distance factor(above 10GHz)) - Gain(Amplifier)

\*Other frequency noises omitted in this report were not seen or had enough margin (more than 20dB).

\*The 10th harmonic was not seen so the result was its base noise level.

Distance factor: 10GHz-26.5GHz 20log(3.0m/1.0m)= 9.5dB

**UL Japan, Inc.**

**Ise EMC Lab.**

4383-326 Asama-cho, Ise-shi, Mie-ken 516-0021 JAPAN

Telephone : +81 596 24 8999

Facsimile : +81 596 24 8124

## Radiated Spurious Emission

### Model No. NR-245UH

Test place Ise EMC Lab. No.2 Semi Anechoic Chamber  
Report No. 10184498H  
Date 01/21/2014 01/22/2014  
Temperature/ Humidity 24 deg. C / 36% RH 20 deg. C / 35% RH  
Engineer Satofumi Matsuyama Tomohisa Nakagawa  
(1-10GHz) (30-1000MHz,  
10-26.5GHz)  
Mode Tx, 3DH5 2402MHz

Polarity	Frequency [MHz]	Detector	Reading [dBuV]	Ant.Fac. [dB/m]	Loss [dB]	Gain [dB]	Result [dBuV/m]	Limit [dBuV/m]	Margin [dB]	Remark
Hori	111.000	QP	38.5	11.6	7.6	28.4	29.3	43.5	14.2	
Hori	112.800	QP	30.8	11.9	7.6	28.4	21.9	43.5	21.6	
Hori	135.199	QP	39.0	14.1	7.7	28.3	32.5	43.5	11.0	
Hori	389.478	QP	29.2	17.0	9.3	28.2	27.3	46.0	18.7	
Hori	430.666	QP	27.5	17.5	9.4	28.5	25.9	46.0	20.1	
Hori	811.003	QP	24.6	21.8	10.9	28.2	29.1	46.0	16.9	
Hori	2390.000	PK	44.2	26.8	2.4	34.7	38.7	73.9	35.2	
Hori	2822.363	PK	49.6	27.3	2.7	34.5	45.1	73.9	28.8	
Hori	4804.000	PK	NS	-	-	-	-	73.9	-	
Hori	7206.000	PK	NS	-	-	-	-	73.9	-	
Hori	9608.000	PK	NS	-	-	-	-	73.9	-	
Hori	2390.000	AV	35.1	26.8	2.4	34.7	29.6	53.9	24.3	
Hori	2822.363	AV	45.5	27.3	2.7	34.5	41.0	53.9	12.9	
Hori	4804.000	AV	NS	-	-	-	-	53.9	-	
Hori	7206.000	AV	NS	-	-	-	-	53.9	-	
Hori	9608.000	AV	NS	-	-	-	-	53.9	-	
Vert	111.000	QP	35.9	11.6	7.6	28.4	26.7	43.5	16.8	
Vert	112.895	QP	32.7	11.9	7.6	28.4	23.8	43.5	19.7	
Vert	135.198	QP	30.5	14.1	7.7	28.3	24.0	43.5	19.5	
Vert	389.485	QP	27.0	17.0	9.3	28.2	25.1	46.0	20.9	
Vert	430.935	QP	27.6	17.6	9.4	28.5	26.1	46.0	19.9	
Vert	811.191	QP	28.8	21.8	10.9	28.2	33.3	46.0	12.7	
Vert	2390.000	PK	43.8	26.8	2.4	34.7	38.3	73.9	35.6	
Vert	2822.327	PK	50.3	27.3	2.7	34.5	45.8	73.9	28.1	
Vert	4804.000	PK	NS	-	-	-	-	73.9	-	
Vert	7206.000	PK	NS	-	-	-	-	73.9	-	
Vert	9608.000	PK	NS	-	-	-	-	73.9	-	
Vert	7206.000	AV	NS	-	-	-	-	53.9	-	
Vert	9608.000	AV	NS	-	-	-	-	53.9	-	

Result = Reading + Ant Factor + Loss (Cable+Attenuator+Filter-Distance factor(above 10GHz)) - Gain(Amplifier)

\*Other frequency noises omitted in this report were not seen or had enough margin (more than 20dB).

\*The 10th harmonic was not seen so the result was its base noise level.

Distance factor: 10GHz-26.5GHz 20log(3.0m/1.0m)= 9.5dB

#### 20dBc Data Sheet

Polarity	Frequency [MHz]	Detector	Reading [dBuV]	Ant Factor [dB/m]	Loss [dB]	Gain [dB]	Result [dBuV/m]	Limit [dBuV/m]	Margin [dB]	Remark
Hori	2402.000	PK	95.3	26.8	2.4	34.7	89.8	-	-	Carrier
Hori	2400.000	PK	46.5	26.8	2.4	34.7	41.0	69.8	28.8	
Vert	2402.000	PK	95.9	26.8	2.4	34.7	90.4	-	-	Carrier
Vert	2400.000	PK	46.9	26.8	2.4	34.7	41.4	70.4	29.0	

Result = Reading + Ant Factor + Loss (Cable+Attenuator+Filter-Distance factor(above 10GHz)) - Gain(Amplifier)

**UL Japan, Inc.**

**Ise EMC Lab.**

4383-326 Asama-cho, Ise-shi, Mie-ken 516-0021 JAPAN

Telephone : +81 596 24 8999

Facsimile : +81 596 24 8124

## Radiated Spurious Emission

### Model No. NR-245UH

Test place Ise EMC Lab. No.2 Semi Anechoic Chamber  
Report No. 10184498H  
Date 01/21/2014 01/22/2014  
Temperature/ Humidity 24 deg. C / 36% RH 20 deg. C / 35% RH  
Engineer Satofumi Matsuyama Tomohisa Nakagawa  
(1-10GHz) (30-1000MHz,  
10-26.5GHz)  
Mode Tx, 3DH5 2441MHz

Polarity	Frequency [MHz]	Detector	Reading [dBuV]	Ant.Fac. [dB/m]	Loss [dB]	Gain [dB]	Result [dBuV/m]	Limit [dBuV/m]	Margin [dB]	Remark
Hori	111.000	QP	38.6	11.6	7.6	28.4	29.4	43.5	14.1	
Hori	112.800	QP	30.3	11.9	7.6	28.4	21.4	43.5	22.1	
Hori	135.199	QP	40.0	14.1	7.7	28.3	33.5	43.5	10.0	
Hori	391.517	QP	32.3	17.0	9.3	28.3	30.3	46.0	15.7	
Hori	430.936	QP	31.3	17.6	9.4	28.5	29.8	46.0	16.2	
Hori	811.003	QP	24.6	21.8	10.9	28.2	29.1	46.0	16.9	
Hori	2822.376	PK	49.4	27.3	2.7	34.5	44.9	73.9	29.0	
Hori	4882.000	PK	NS	-	-	-	-	73.9	-	
Hori	7323.000	PK	NS	-	-	-	-	73.9	-	
Hori	9764.000	PK	NS	-	-	-	-	73.9	-	
Hori	2822.376	AV	45.6	27.3	2.7	34.5	41.1	53.9	12.8	
Hori	4882.000	AV	NS	-	-	-	-	53.9	-	
Hori	7323.000	AV	NS	-	-	-	-	53.9	-	
Hori	9764.000	AV	NS	-	-	-	-	53.9	-	
Vert	111.000	QP	34.5	11.6	7.6	28.4	25.3	43.5	18.2	
Vert	112.895	QP	32.7	11.9	7.6	28.4	23.8	43.5	19.7	
Vert	135.198	QP	29.1	14.1	7.7	28.3	22.6	43.5	20.9	
Vert	389.444	QP	27.4	17.0	9.3	28.2	25.5	46.0	20.5	
Vert	430.875	QP	29.0	17.5	9.4	28.5	27.4	46.0	18.6	
Vert	811.190	QP	28.3	21.8	10.9	28.2	32.8	46.0	13.2	
Vert	2822.333	PK	50.2	27.3	2.7	34.5	45.7	73.9	28.2	
Vert	7323.000	PK	NS	-	-	-	-	73.9	-	
Vert	9764.000	PK	NS	-	-	-	-	73.9	-	
Vert	2822.333	AV	46.4	27.3	2.7	34.5	41.9	53.9	12.0	
Vert	4882.000	AV	NS	-	-	-	-	53.9	-	
Vert	7323.000	AV	NS	-	-	-	-	53.9	-	
Vert	9764.000	AV	NS	-	-	-	-	53.9	-	

Result = Reading + Ant Factor + Loss (Cable+Attenuator+Filter-Distance factor(above 10GHz)) - Gain(Amplifier)  
\*Other frequency noises omitted in this report were not seen or had enough margin (more than 20dB).  
\*The 10th harmonic was not seen so the result was its base noise level.  
Distance factor: 10GHz-26.5GHz 20log(3.0m/1.0m)= 9.5dB

## Radiated Spurious Emission

### Model No. NR-245UH

Test place Ise EMC Lab. No.2 Semi Anechoic Chamber  
Report No. 10184498H  
Date 01/21/2014 01/22/2014  
Temperature/ Humidity 24 deg. C / 36% RH 20 deg. C / 35% RH  
Engineer Satofumi Matsuyama Tomohisa Nakagawa  
(1-10GHz) (30-1000MHz,  
10-26.5GHz)  
Mode Tx, 3DH5 2480MHz

Polarity	Frequency [MHz]	Detector	Reading [dBuV]	Ant.Fac. [dB/m]	Loss [dB]	Gain [dB]	Result [dBuV/m]	Limit [dBuV/m]	Margin [dB]	Remark
Hori	111.000	QP	38.3	11.6	7.6	28.4	29.1	43.5	14.4	
Hori	112.800	QP	30.5	11.9	7.6	28.4	21.6	43.5	21.9	
Hori	135.199	QP	39.3	14.1	7.7	28.3	32.8	43.5	10.7	
Hori	391.517	QP	32.1	17.0	9.3	28.3	30.1	46.0	15.9	
Hori	430.936	QP	31.8	17.6	9.4	28.5	30.3	46.0	15.7	
Hori	811.003	QP	24.5	21.8	10.9	28.2	29.0	46.0	17.0	
Hori	2483.500	PK	47.1	26.7	2.5	34.7	41.6	73.9	32.3	
Hori	2822.328	PK	49.2	27.3	2.7	34.5	44.7	73.9	29.2	
Hori	4960.000	PK	NS	-	-	-	-	73.9	-	
Hori	7440.000	PK	NS	-	-	-	-	73.9	-	
Hori	9920.000	PK	NS	-	-	-	-	73.9	-	
Hori	2483.500	AV	36.8	26.7	2.5	34.7	31.3	53.9	22.6	
Hori	2822.328	AV	45.7	27.3	2.7	34.5	41.2	53.9	12.7	
Hori	4960.000	AV	NS	-	-	-	-	53.9	-	
Hori	7440.000	AV	NS	-	-	-	-	53.9	-	
Hori	9920.000	AV	NS	-	-	-	-	53.9	-	
Vert	111.000	QP	35.7	11.6	7.6	28.4	26.5	43.5	17.0	
Vert	112.895	QP	32.5	11.9	7.6	28.4	23.6	43.5	19.9	
Vert	135.198	QP	29.5	14.1	7.7	28.3	23.0	43.5	20.5	
Vert	389.444	QP	27.4	17.0	9.3	28.2	25.5	46.0	20.5	
Vert	430.875	QP	28.3	17.5	9.4	28.5	26.7	46.0	19.3	
Vert	811.190	QP	28.1	21.8	10.9	28.2	32.6	46.0	13.4	
Vert	2483.500	PK	46.0	26.7	2.5	34.7	40.5	73.9	33.4	
Vert	4960.000	PK	NS	-	-	-	-	73.9	-	
Vert	7440.000	PK	NS	-	-	-	-	73.9	-	
Vert	9920.000	PK	NS	-	-	-	-	73.9	-	
Vert	2483.500	AV	36.5	26.7	2.5	34.7	31.0	53.9	22.9	
Vert	2822.341	AV	46.3	27.3	2.7	34.5	41.8	53.9	12.1	
Vert	4960.000	AV	NS	-	-	-	-	53.9	-	
Vert	7440.000	AV	NS	-	-	-	-	53.9	-	
Vert	9920.000	AV	NS	-	-	-	-	53.9	-	

Result = Reading + Ant Factor + Loss (Cable+Attenuator+Filter-Distance factor(above 10GHz)) - Gain(Amplifier)

\*Other frequency noises omitted in this report were not seen or had enough margin (more than 20dB).

\*The 10th harmonic was not seen so the result was its base noise level.

Distance factor: 10GHz-26.5GHz  $20\log(3.0m/1.0m) = 9.5dB$

**UL Japan, Inc.**

**Ise EMC Lab.**

4383-326 Asama-cho, Ise-shi, Mie-ken 516-0021 JAPAN

Telephone : +81 596 24 8999

Facsimile : +81 596 24 8124

### Burst Rate Confirmation

#### Model No. NR-244UH

Test place	Ise EMC Lab. No.2 Semi Anechoic Chamber
Report No.	10184498H
Date	01/29/2014
Temperature/ Humidity	23 deg. C / 34% RH
Engineer	Satofumi Matsuyama
Mode	Tx DH5/3DH5

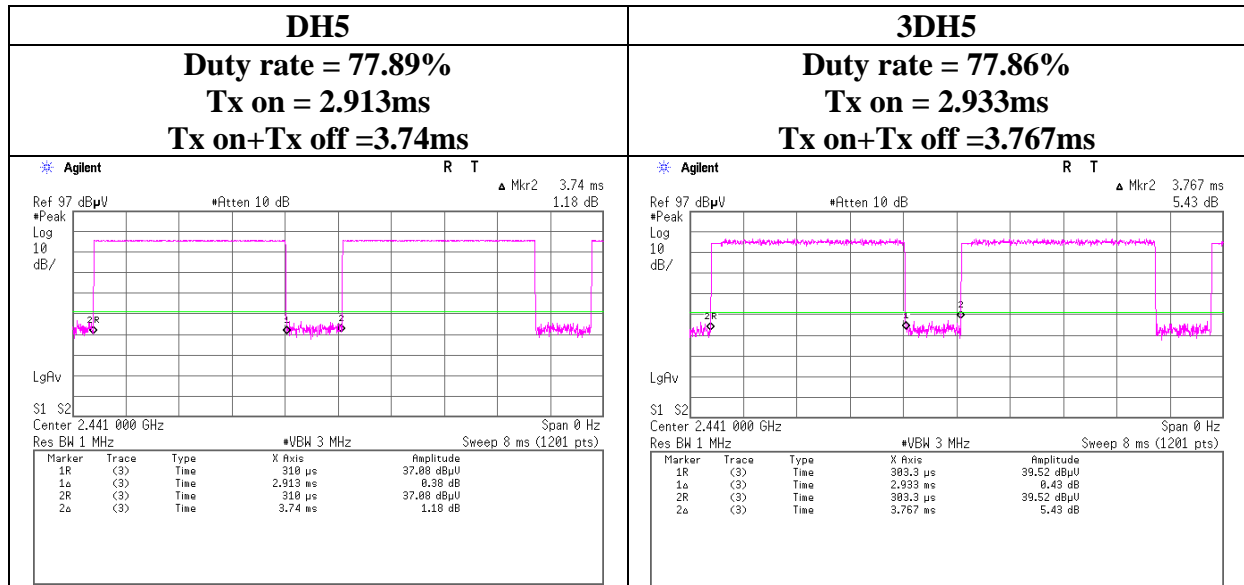

**UL Japan, Inc.**

**Ise EMC Lab.**

4383-326 Asama-cho, Ise-shi, Mie-ken 516-0021 JAPAN

Telephone : +81 596 24 8999

Facsimile : +81 596 24 8124



**Dwell time factor**  
**Model No. NR-244UH**

Test place	Ise EMC Lab. No.2 Semi Anechoic Chamber
Report No.	10184498H
Date	01/29/2014
Temperature/ Humidity	23 deg. C / 34% RH
Engineer	Satofumi Matsuyama
Mode	Tx DH5/3DH5

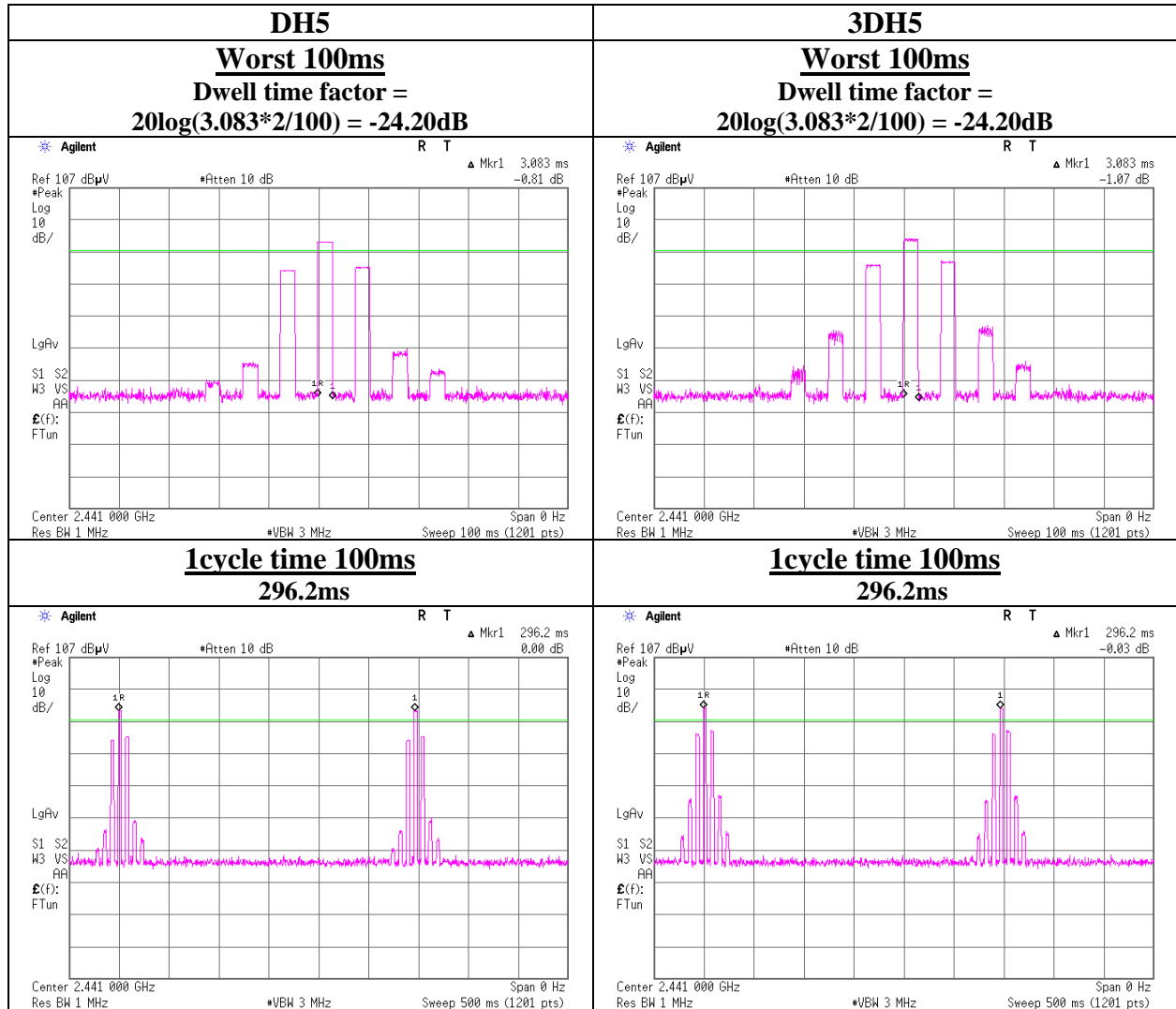

## Conducted Spurious Emission

### Model No. NR-244UH

Test place	Ise EMC Lab. No.06 Measurement Room
Report No.	10184498H
Date	01/15/2014
Temperature/ Humidity	21 deg.C/ 31% RH
Engineer	Masatoshi Nishiguchi
Mode	Tx (Hopping off) DH5/3DH5

### Tx DH5 2441MHz

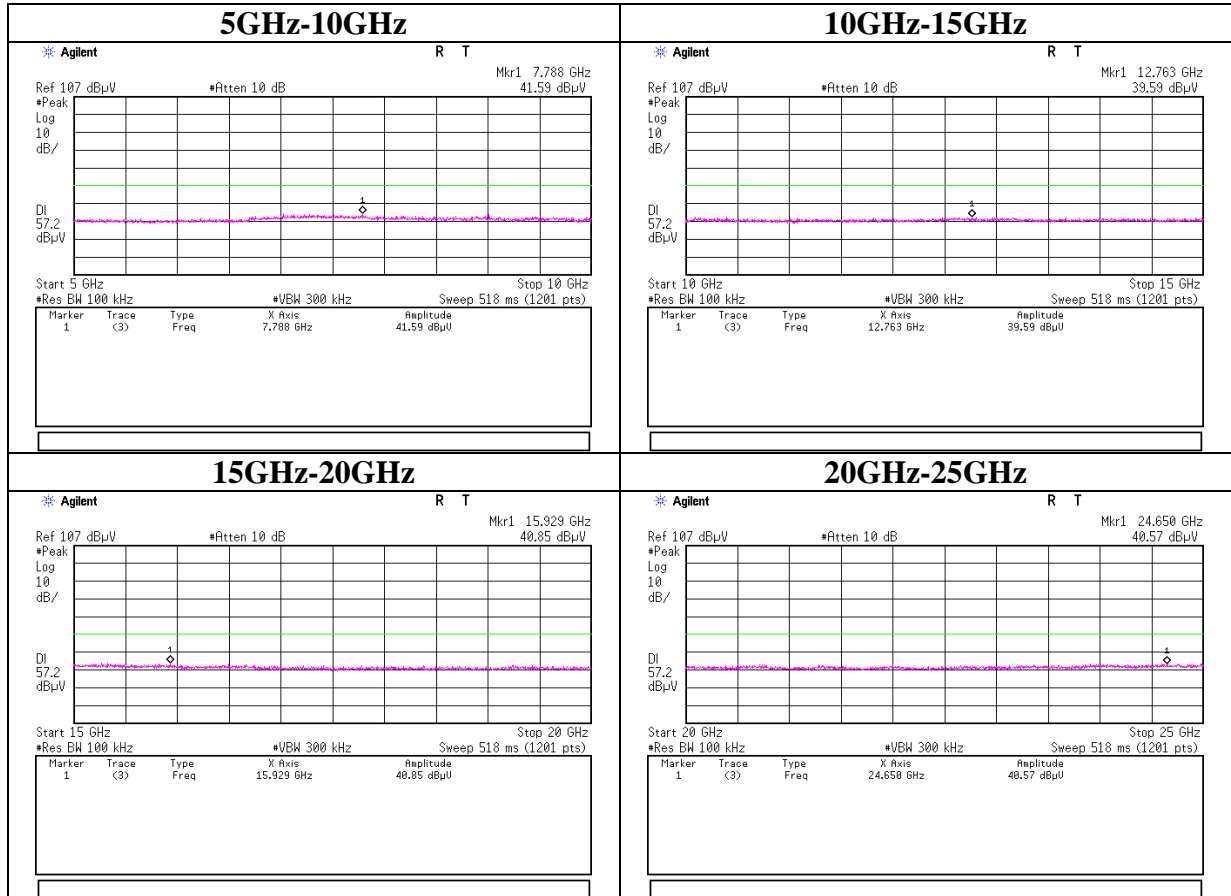

**UL Japan, Inc.**

**Ise EMC Lab.**

4383-326 Asama-cho, Ise-shi, Mie-ken 516-0021 JAPAN

Telephone : +81 596 24 8999

Facsimile : +81 596 24 8124

## Conducted Spurious Emission

### Model No. NR-244UH

Test place	Ise EMC Lab. No.06 Measurement Room
Report No.	10184498H
Date	01/15/2014
Temperature/ Humidity	21 deg.C/ 31% RH
Engineer	Masatoshi Nishiguchi
Mode	Tx (Hopping off) DH5/3DH5

### Tx DH5 2480MHz

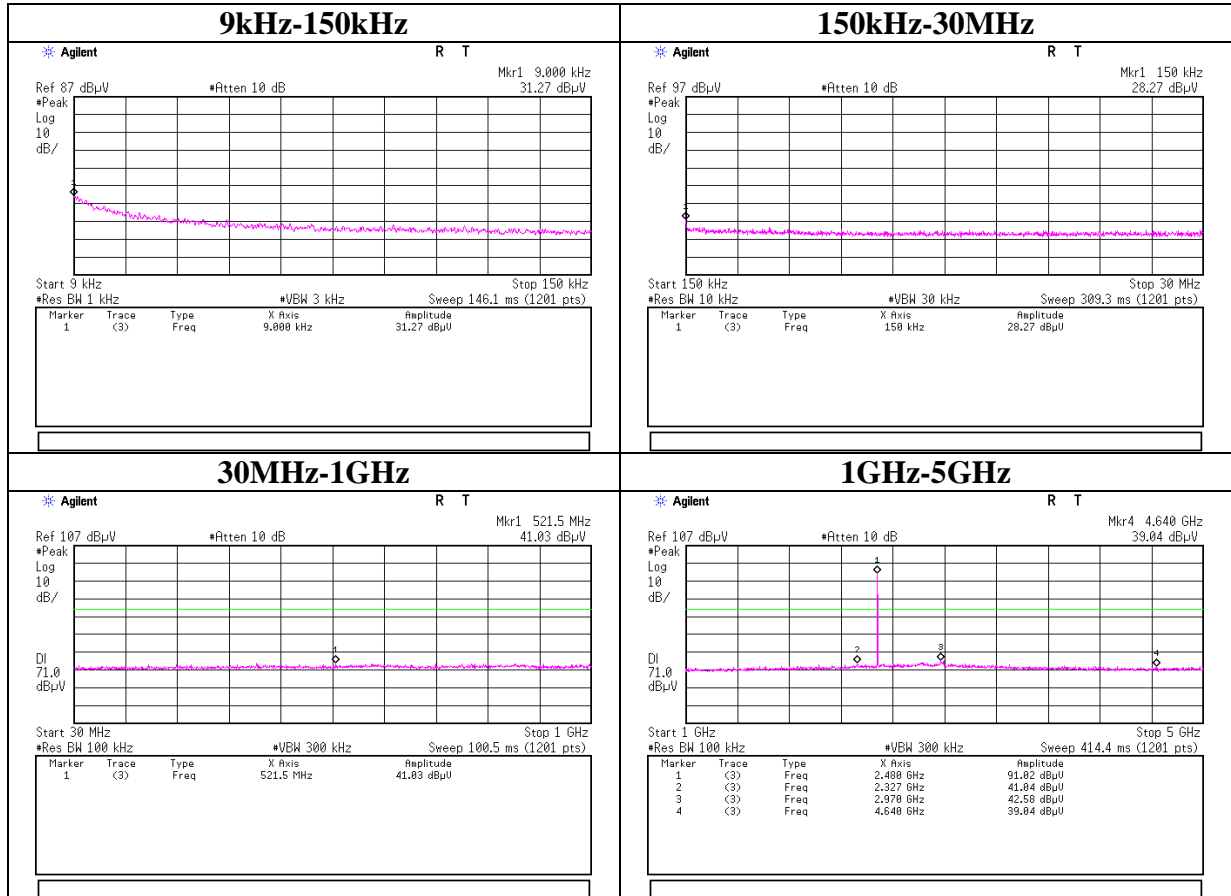

**UL Japan, Inc.**  
**Ise EMC Lab.**

4383-326 Asama-cho, Ise-shi, Mie-ken 516-0021 JAPAN  
 Telephone : +81 596 24 8999  
 Facsimile : +81 596 24 8124

## Conducted Spurious Emission

### Model No. NR-244UH

Test place	Ise EMC Lab. No.06 Measurement Room
Report No.	10184498H
Date	01/15/2014
Temperature/ Humidity	21 deg.C/ 31% RH
Engineer	Masatoshi Nishiguchi
Mode	Tx (Hopping off) DH5/3DH5

### Tx DH5 2480MHz

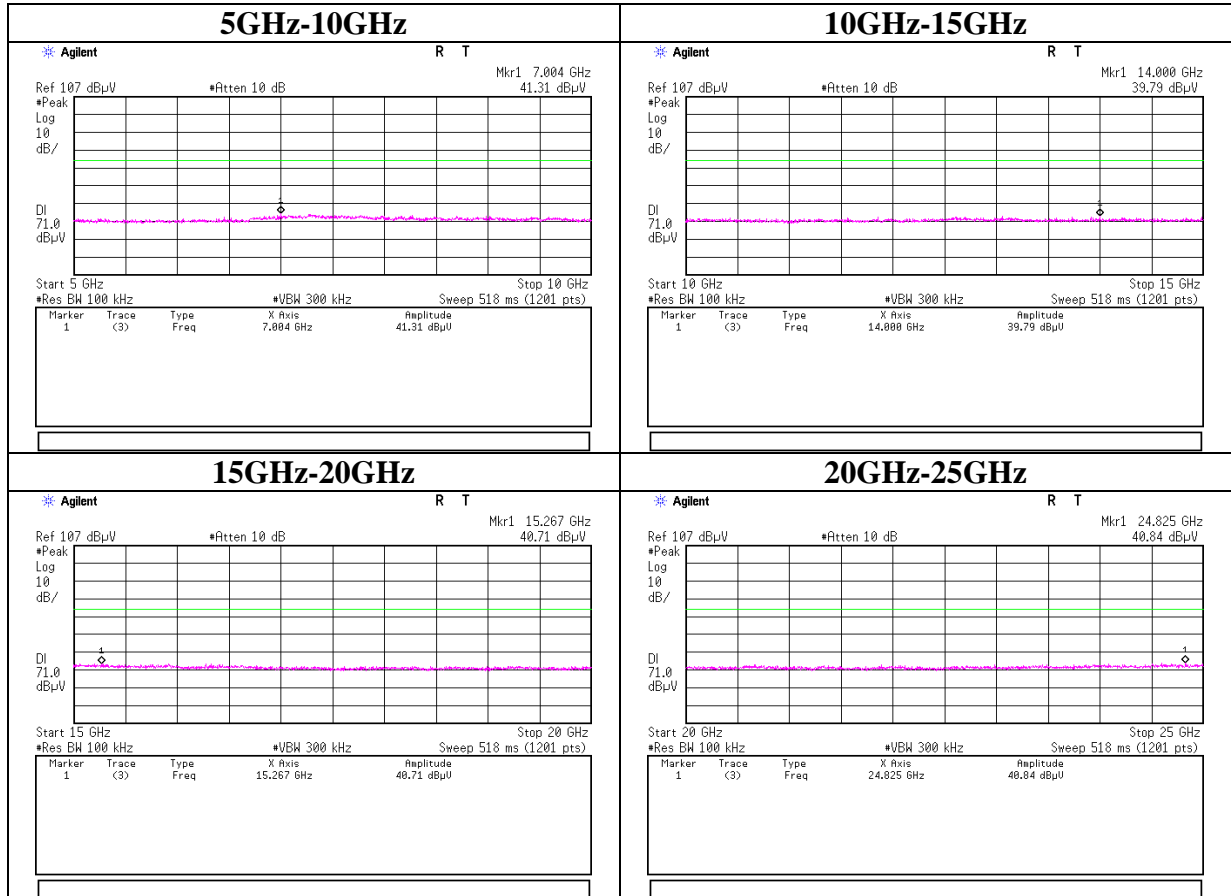

**UL Japan, Inc.**

**Ise EMC Lab.**

4383-326 Asama-cho, Ise-shi, Mie-ken 516-0021 JAPAN

Telephone : +81 596 24 8999

Facsimile : +81 596 24 8124

## Conducted Spurious Emission

### Model No. NR-244UH

Test place	Ise EMC Lab. No.06 Measurement Room
Report No.	10184498H
Date	01/15/2014
Temperature/ Humidity	21 deg.C/ 31% RH
Engineer	Masatoshi Nishiguchi
Mode	Tx (Hopping off) DH5/3DH5

### Tx 3DH5 2402MHz

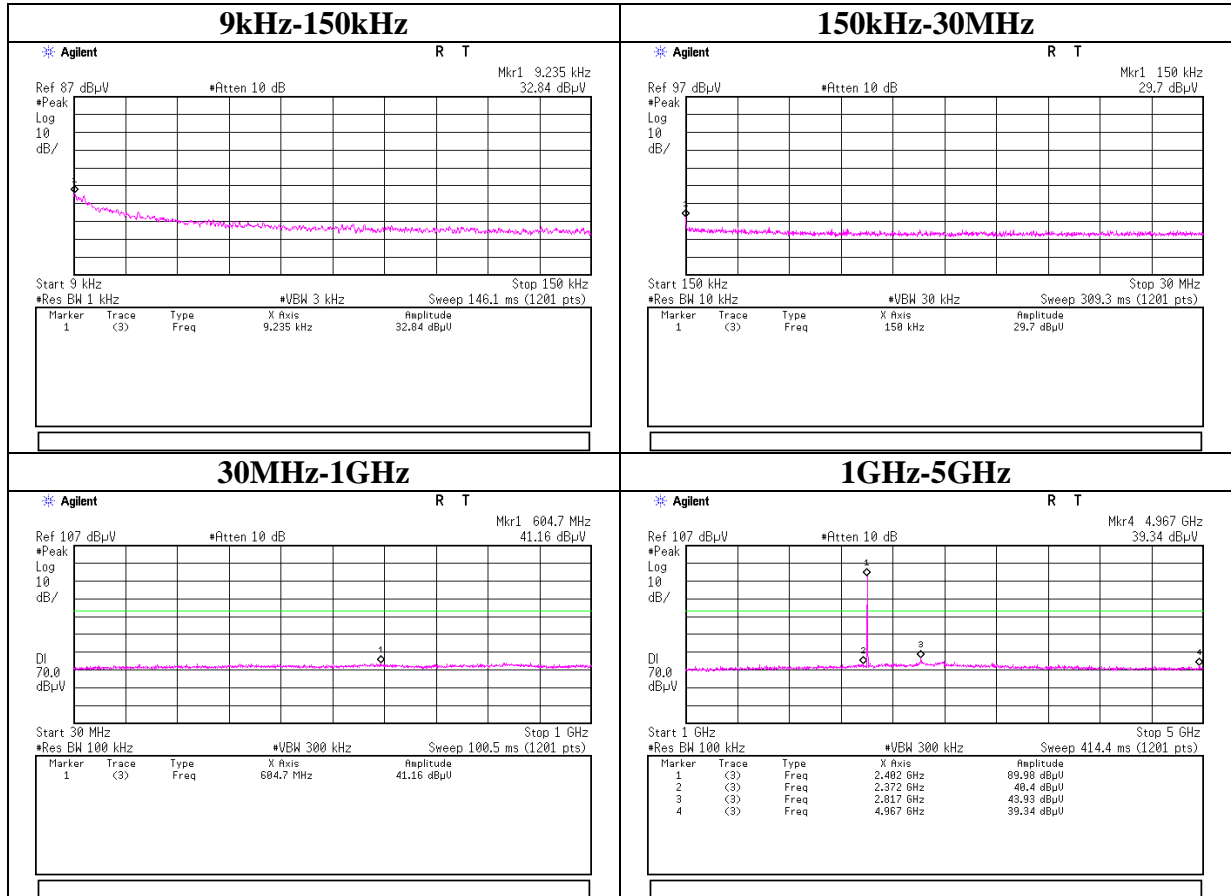

**UL Japan, Inc.**  
**Ise EMC Lab.**

4383-326 Asama-cho, Ise-shi, Mie-ken 516-0021 JAPAN  
 Telephone : +81 596 24 8999  
 Facsimile : +81 596 24 8124

## Conducted Spurious Emission

### Model No. NR-244UH

Test place	Ise EMC Lab. No.06 Measurement Room
Report No.	10184498H
Date	01/15/2014
Temperature/ Humidity	21 deg.C/ 31% RH
Engineer	Masatoshi Nishiguchi
Mode	Tx (Hopping off) DH5/3DH5

### Tx 3DH5 2402MHz

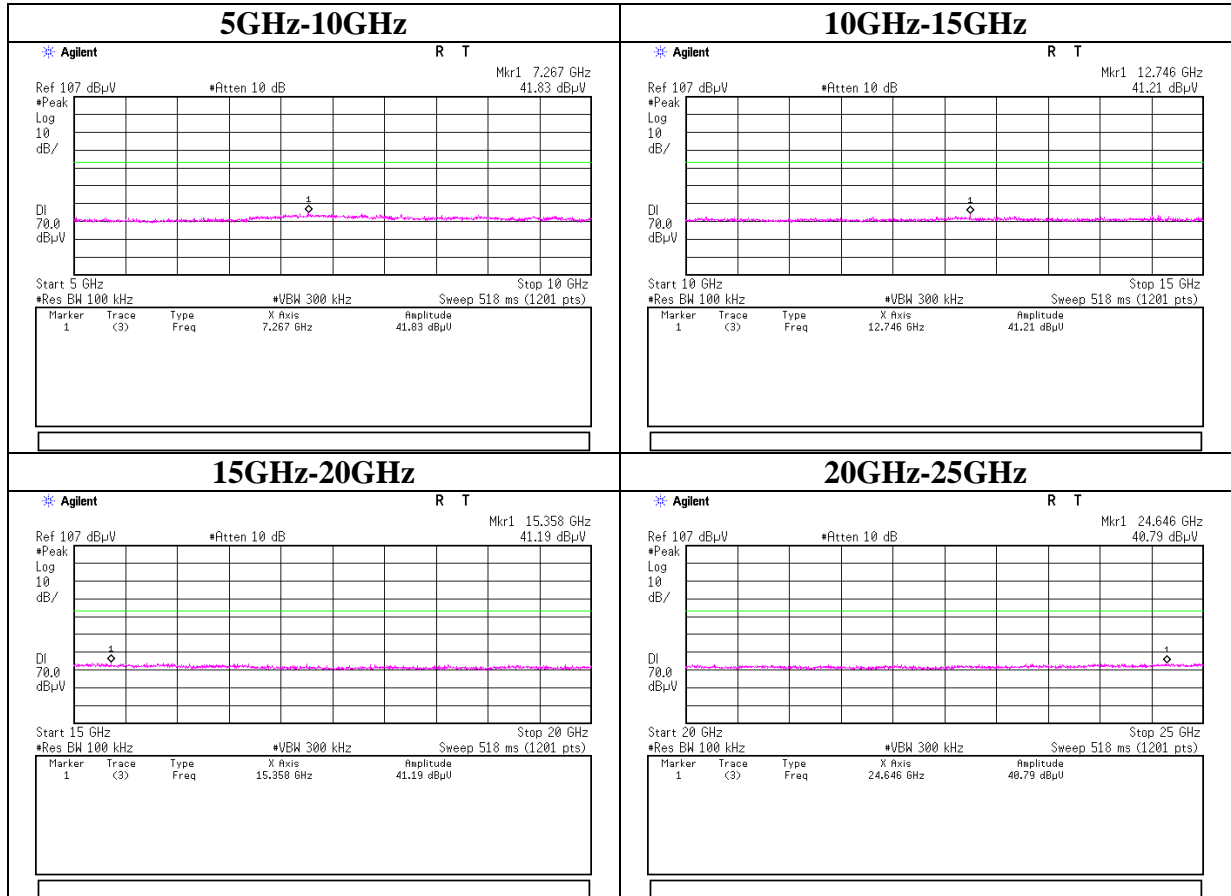

**UL Japan, Inc.**  
**Ise EMC Lab.**

4383-326 Asama-cho, Ise-shi, Mie-ken 516-0021 JAPAN  
 Telephone : +81 596 24 8999  
 Facsimile : +81 596 24 8124

## Conducted Spurious Emission

### Model No. NR-244UH

Test place	Ise EMC Lab. No.06 Measurement Room
Report No.	10184498H
Date	01/15/2014
Temperature/ Humidity	21 deg.C/ 31% RH
Engineer	Masatoshi Nishiguchi
Mode	Tx (Hopping off) DH5/3DH5

### Tx 3DH5 2441MHz

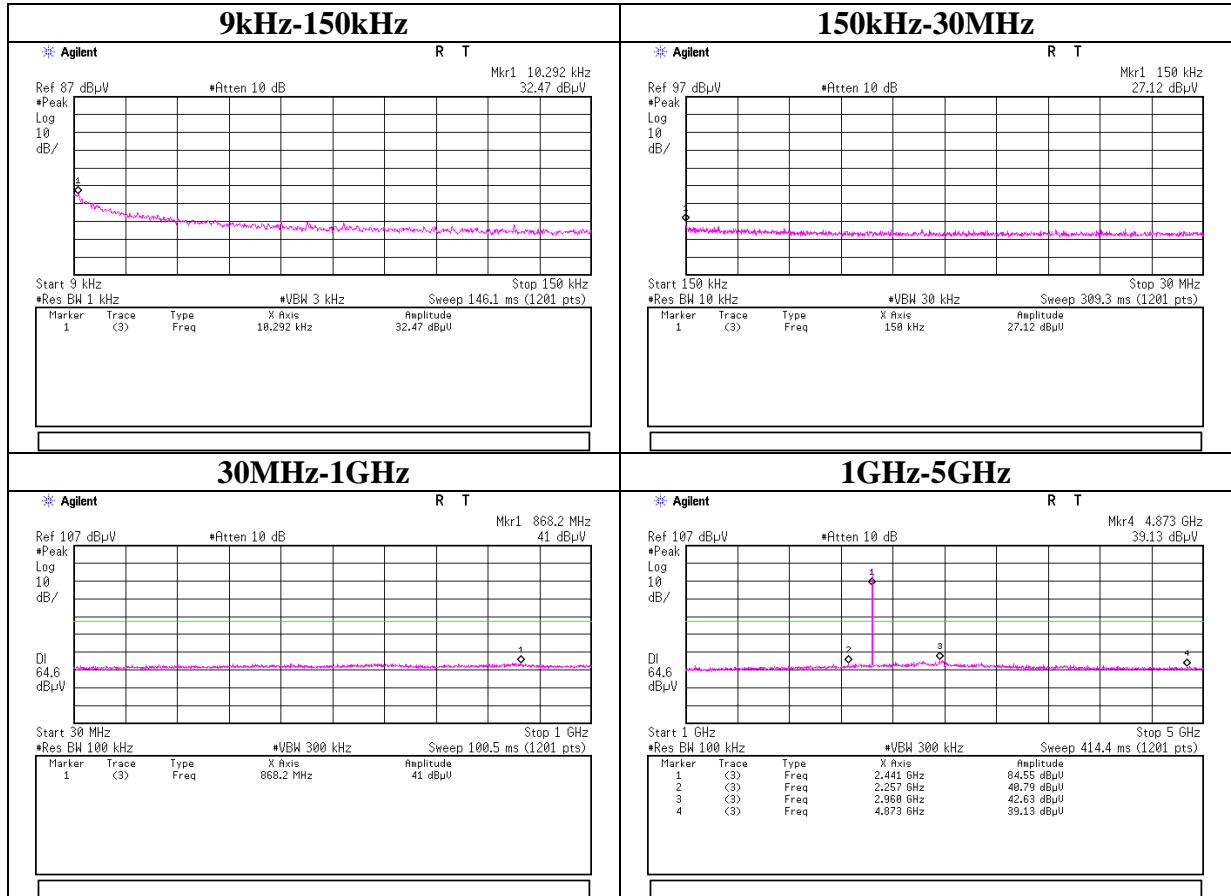

**UL Japan, Inc.**

**Ise EMC Lab.**

4383-326 Asama-cho, Ise-shi, Mie-ken 516-0021 JAPAN

Telephone : +81 596 24 8999

Facsimile : +81 596 24 8124

## Conducted Spurious Emission

### Model No. NR-244UH

Test place	Ise EMC Lab. No.06 Measurement Room
Report No.	10184498H
Date	01/15/2014
Temperature/ Humidity	21 deg.C/ 31% RH
Engineer	Masatoshi Nishiguchi
Mode	Tx (Hopping off) DH5/3DH5

### Tx 3DH5 2441MHz

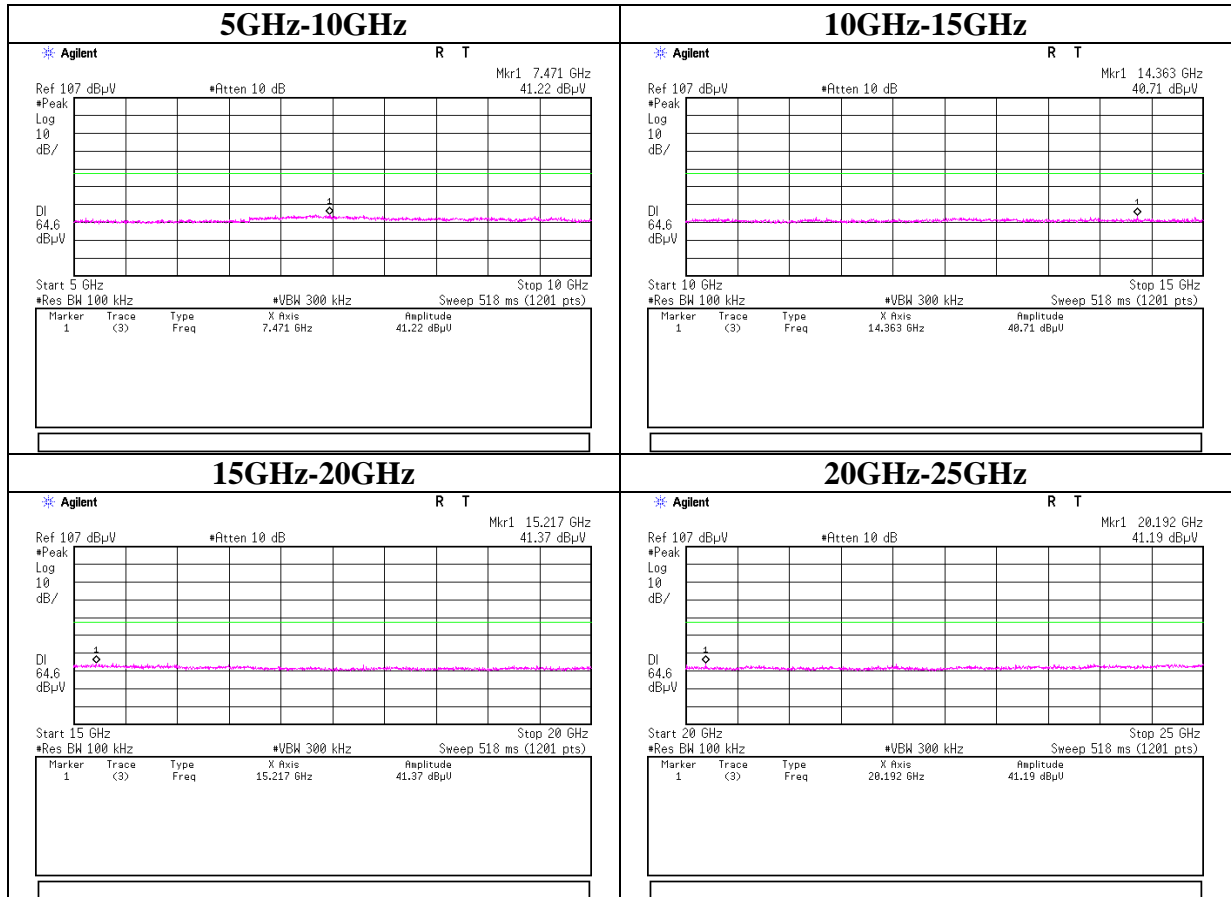

**UL Japan, Inc.**

**Ise EMC Lab.**

4383-326 Asama-cho, Ise-shi, Mie-ken 516-0021 JAPAN

Telephone : +81 596 24 8999

Facsimile : +81 596 24 8124



## Conducted Spurious Emission

### Model No. NR-244UH

Test place	Ise EMC Lab. No.06 Measurement Room
Report No.	10184498H
Date	01/15/2014
Temperature/ Humidity	21 deg.C/ 31% RH
Engineer	Masatoshi Nishiguchi
Mode	Tx (Hopping off) DH5/3DH5

### Tx 3DH5 2480MHz

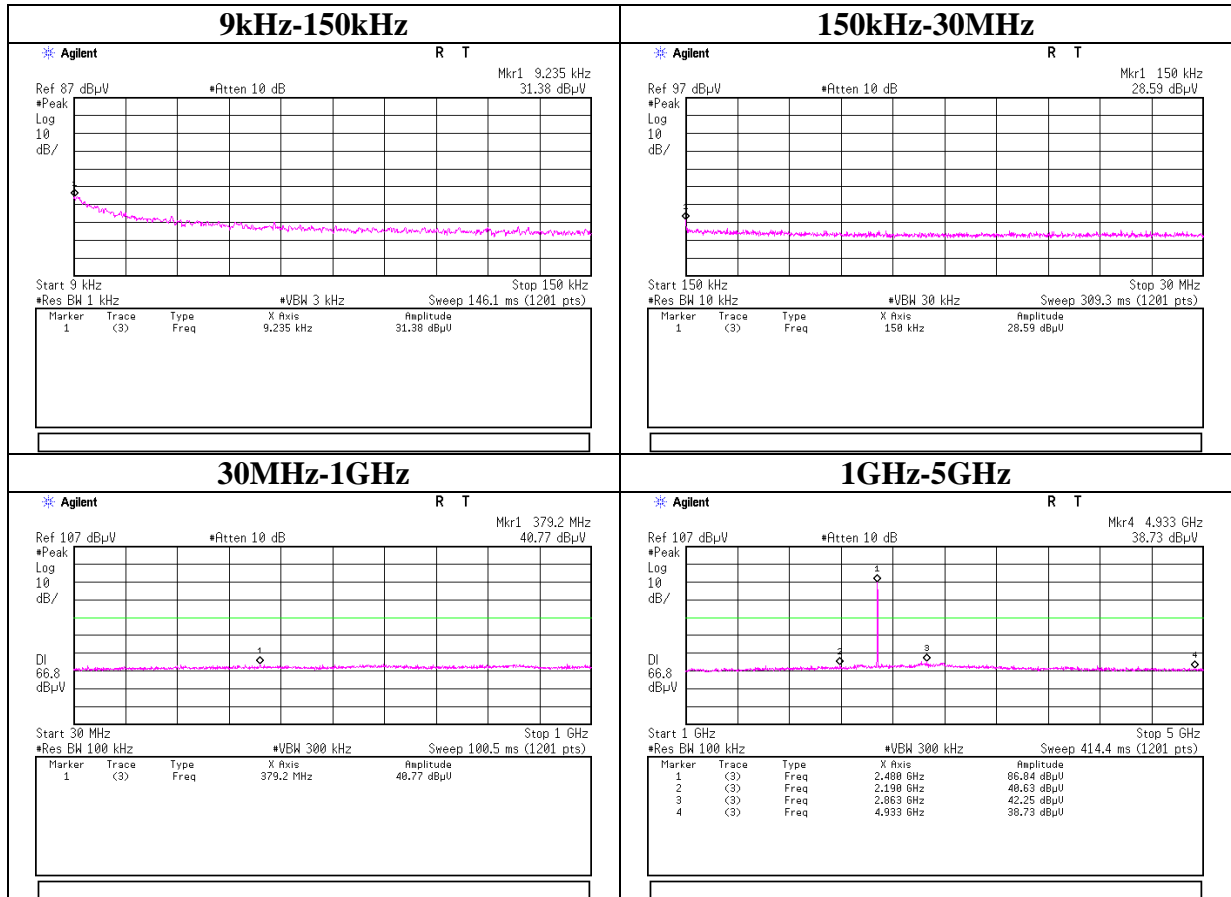

**UL Japan, Inc.**  
**Ise EMC Lab.**

4383-326 Asama-cho, Ise-shi, Mie-ken 516-0021 JAPAN  
 Telephone : +81 596 24 8999  
 Facsimile : +81 596 24 8124

## Conducted Spurious Emission

### Model No. NR-244UH

Test place	Ise EMC Lab. No.06 Measurement Room
Report No.	10184498H
Date	01/15/2014
Temperature/ Humidity	21 deg.C/ 31% RH
Engineer	Masatoshi Nishiguchi
Mode	Tx (Hopping off) DH5/3DH5

### Tx 3DH5 2480MHz

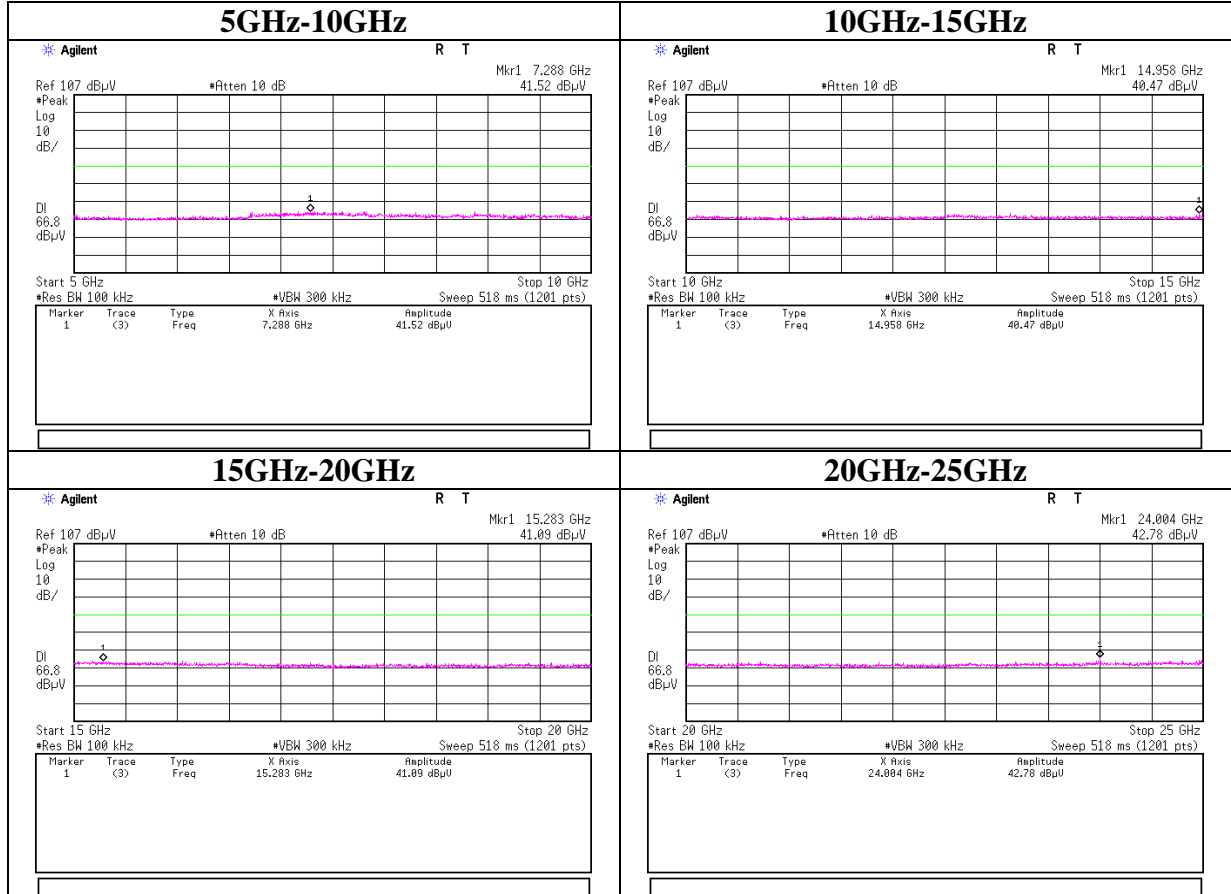

**UL Japan, Inc.**  
**Ise EMC Lab.**

4383-326 Asama-cho, Ise-shi, Mie-ken 516-0021 JAPAN  
 Telephone : +81 596 24 8999  
 Facsimile : +81 596 24 8124

## Conducted Spurious Emission

### Model No. NR-244UH

Test place	Ise EMC Lab. No.06 Measurement Room
Report No.	10184498H
Date	01/29/2014
Temperature/ Humidity	23 deg. C / 34% RH
Engineer	Satofumi Matsuyama
Mode	Tx (Hopping off) DH5/3DH5

### Tx DH5 2402MHz

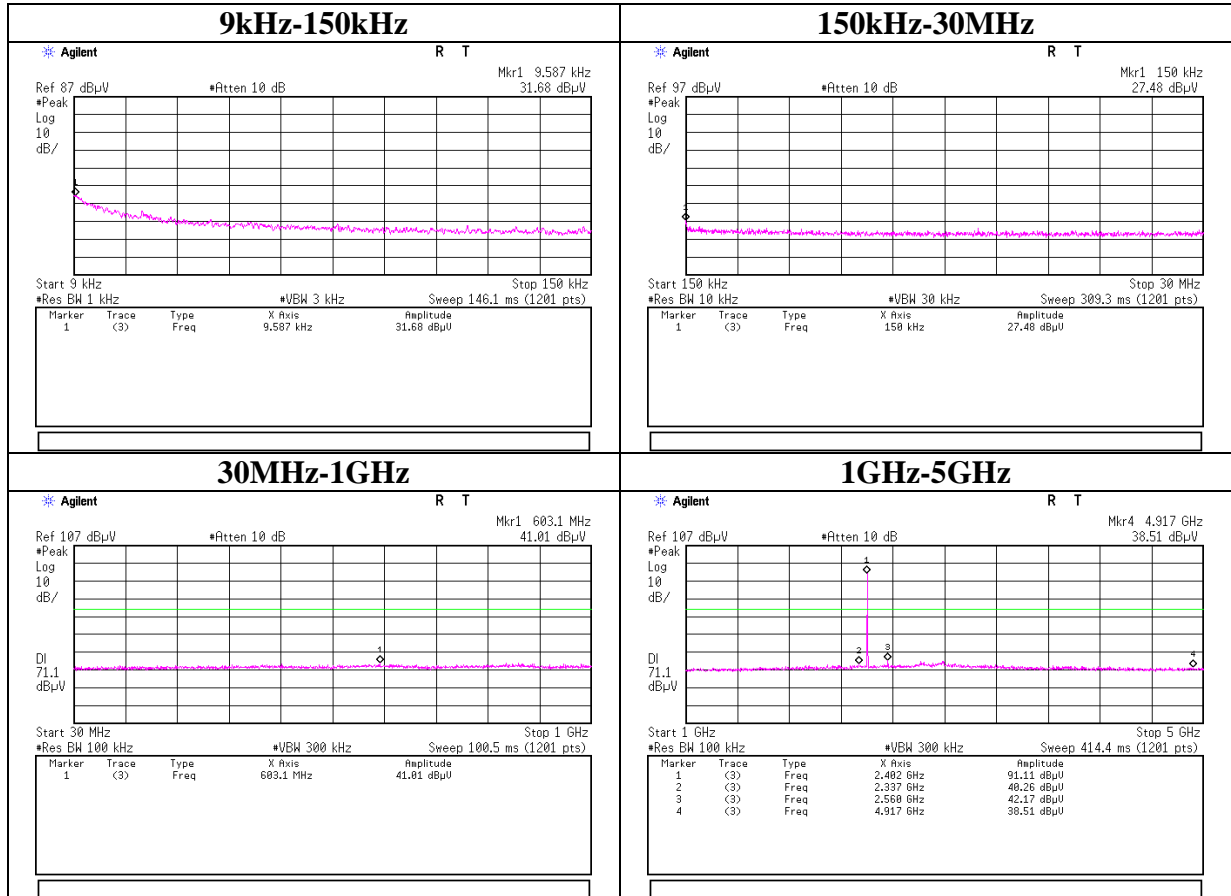

**UL Japan, Inc.**

**Ise EMC Lab.**

4383-326 Asama-cho, Ise-shi, Mie-ken 516-0021 JAPAN

Telephone : +81 596 24 8999

Facsimile : +81 596 24 8124

## Conducted Spurious Emission

### Model No. NR-244UH

Test place	Ise EMC Lab. No.06 Measurement Room
Report No.	10184498H
Date	01/15/2014
Temperature/ Humidity	21 deg.C/ 31% RH
Engineer	Masatoshi Nishiguchi
Mode	Tx (Hopping off) DH5/3DH5

### Tx DH5 2402MHz

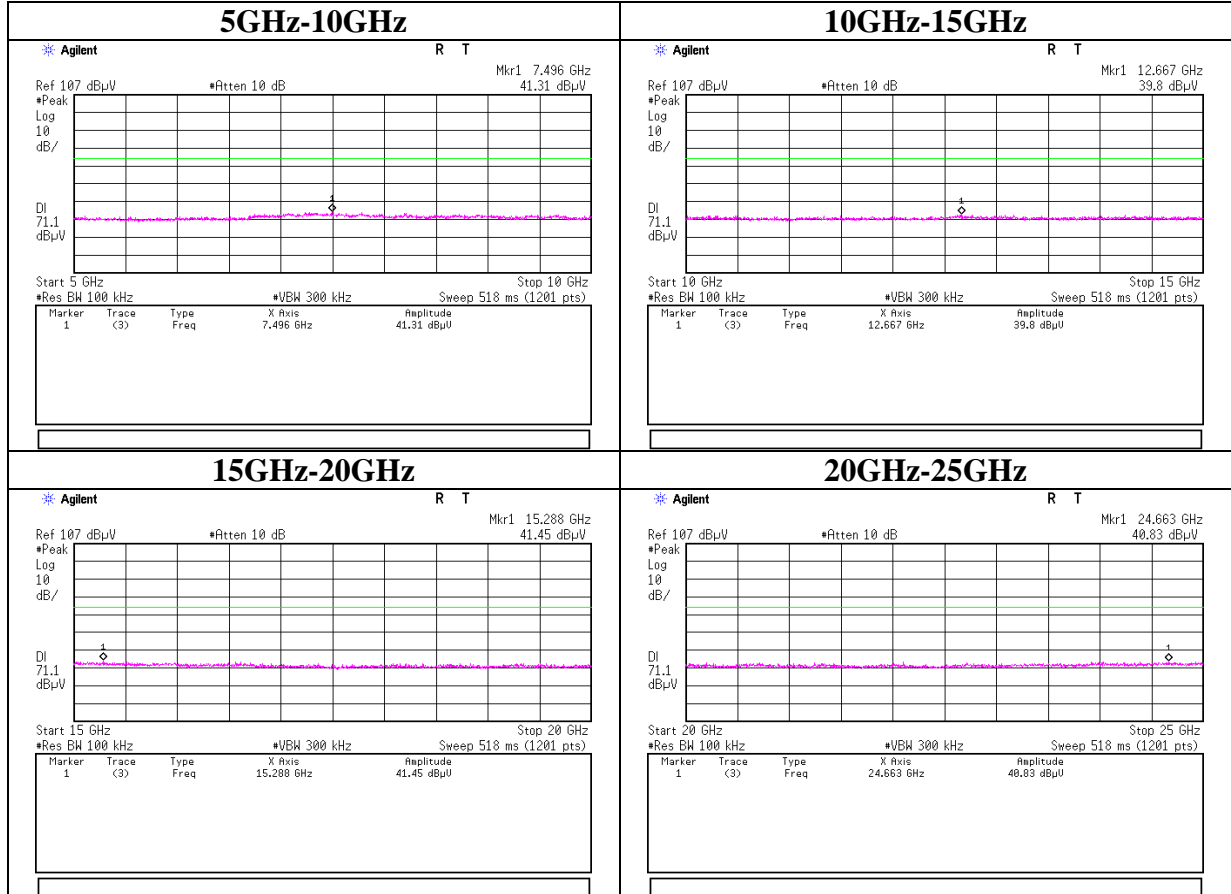

**UL Japan, Inc.**

**Ise EMC Lab.**

4383-326 Asama-cho, Ise-shi, Mie-ken 516-0021 JAPAN

Telephone : +81 596 24 8999

Facsimile : +81 596 24 8124

## Conducted Spurious Emission

### Model No. NR-244UH

Test place	Ise EMC Lab. No.06 Measurement Room
Report No.	10184498H
Date	01/15/2014
Temperature/ Humidity	21 deg.C/ 31% RH
Engineer	Masatoshi Nishiguchi
Mode	Tx (Hopping off) DH5/3DH5

### Tx DH5 2441MHz

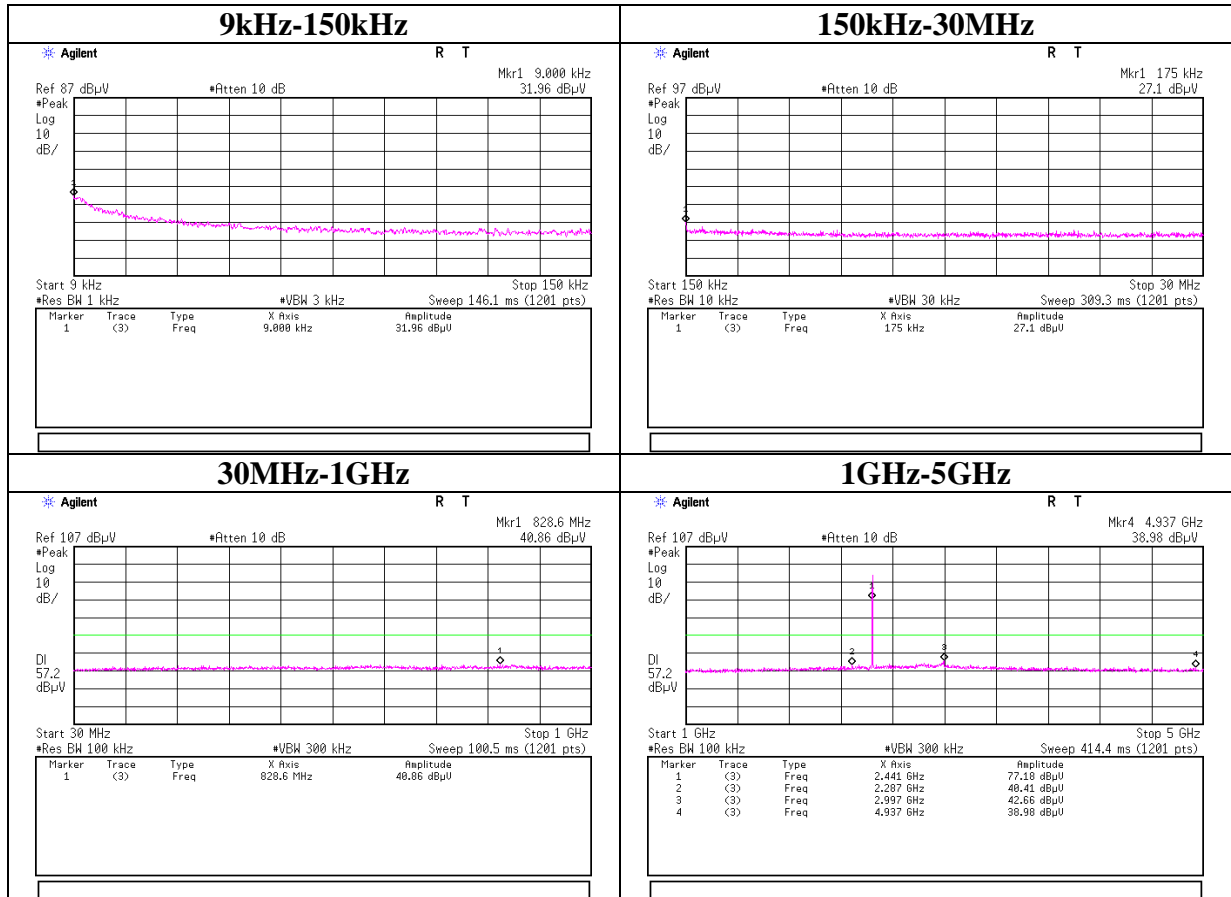

**UL Japan, Inc.**  
**Ise EMC Lab.**

4383-326 Asama-cho, Ise-shi, Mie-ken 516-0021 JAPAN  
 Telephone : +81 596 24 8999  
 Facsimile : +81 596 24 8124

### Conducted Emission Band Edge compliance

#### Model No. NR-244UH

Test place : Ise EMC Lab. No.06 Measurement Room  
 Report No. : 10184498H  
 Date : 01/15/2014  
 Temperature/ Humidity : 21 deg.C/ 31% RH  
 Engineer : Masatoshi Nishiguchi  
 Mode : Tx (Hopping off) DH5/3DH5

#### Tx DH5, Hopping on

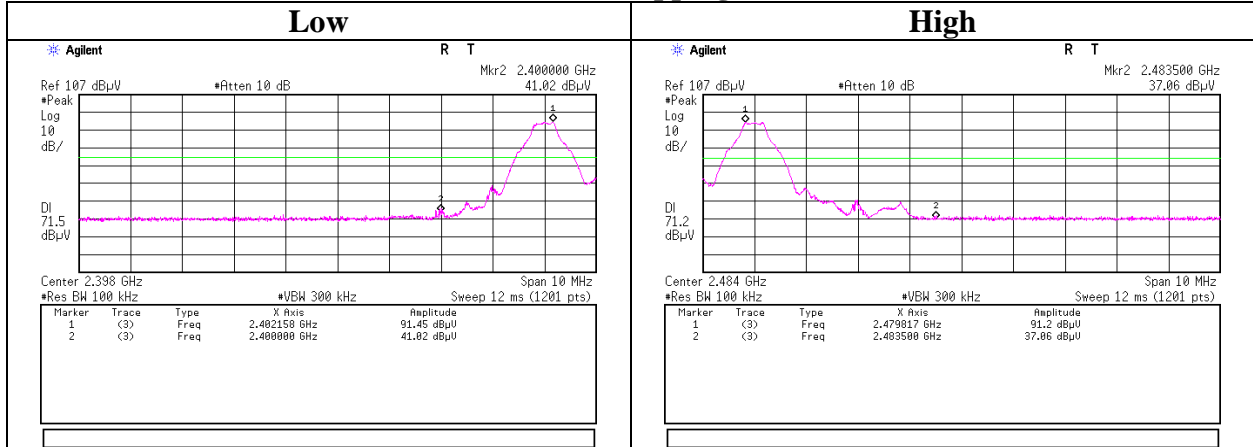

#### Tx DH5, Hopping off

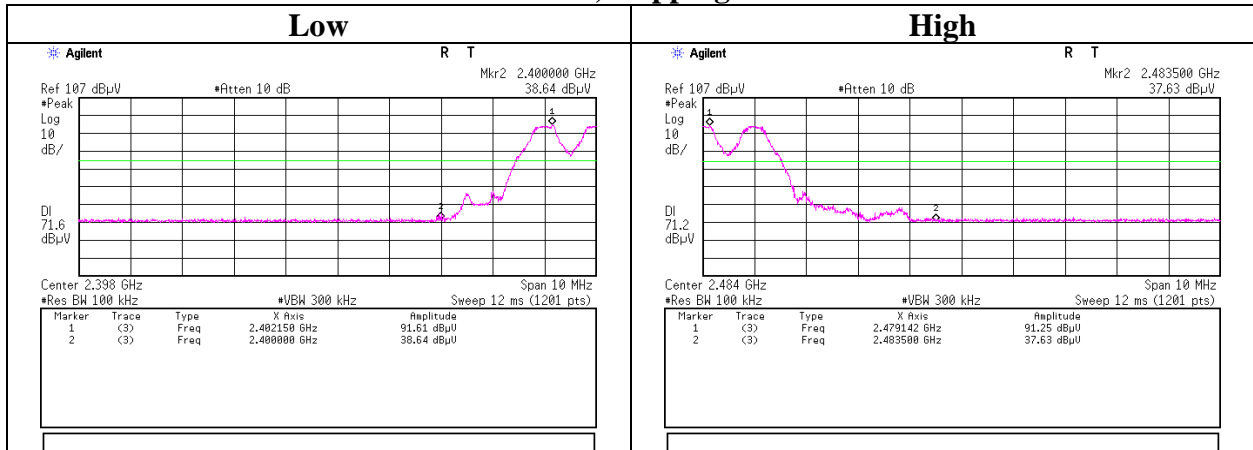

UL Japan, Inc.

Ise EMC Lab.

4383-326 Asama-cho, Ise-shi, Mie-ken 516-0021 JAPAN

Telephone : +81 596 24 8999

Facsimile : +81 596 24 8124

## Conducted Emission Band Edge compliance

### Model No. NR-244UH

Test place	Ise EMC Lab. No.06 Measurement Room
Report No.	10184498H
Date	01/15/2014
Temperature/ Humidity	21 deg.C/ 31% RH
Engineer	Masatoshi Nishiguchi
Mode	Tx (Hopping off) DH5/3DH5

### Tx 3DH5, Hopping on

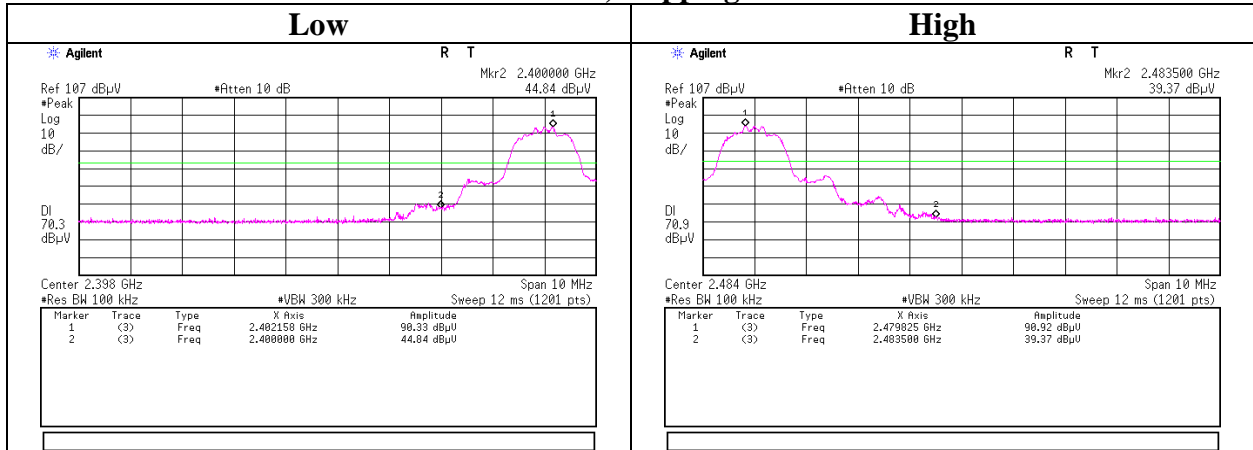

### Tx 3DH5, Hopping off

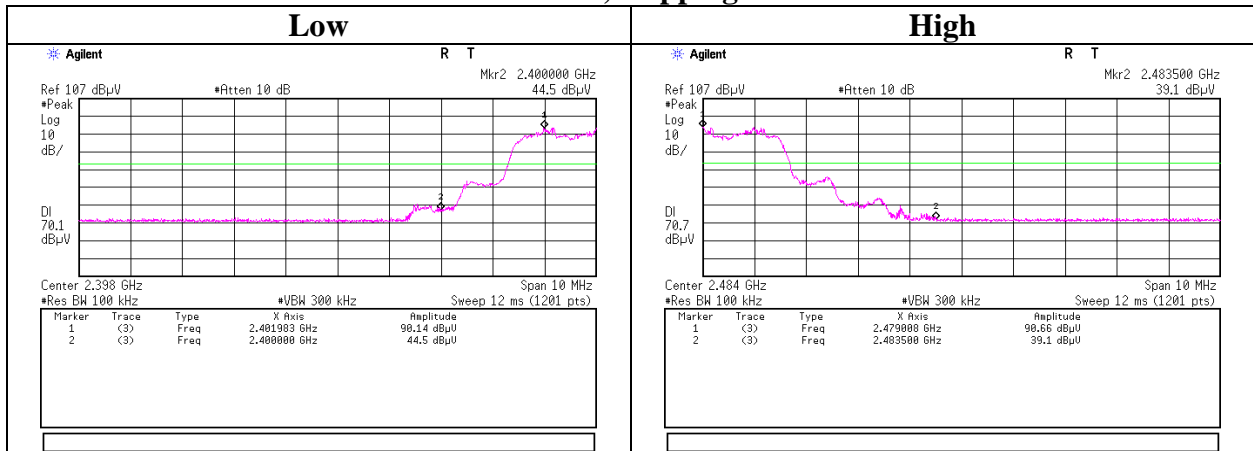

**UL Japan, Inc.**

**Ise EMC Lab.**

4383-326 Asama-cho, Ise-shi, Mie-ken 516-0021 JAPAN

Telephone : +81 596 24 8999

Facsimile : +81 596 24 8124

**99% Occupied Bandwidth**  
**Model No. NR-244UH**

Test place	Ise EMC Lab. No.06 Measurement Room
Report No.	10184498H
Date	01/15/2014
Temperature/ Humidity	21 deg.C/ 31% RH
Engineer	Masatoshi Nishiguchi
Mode	Tx (Hopping off) DH5/3DH5

**Tx DH5, Hopping off**

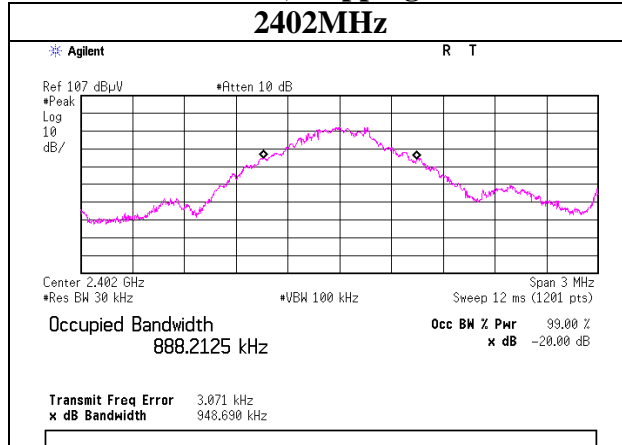

**Tx 3DH5, Hopping off**

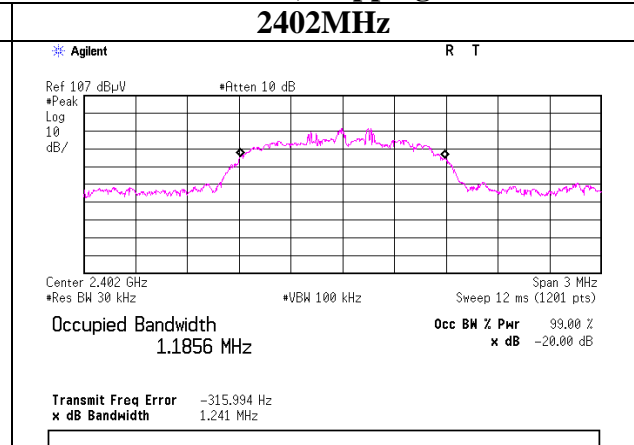

**2441MHz**

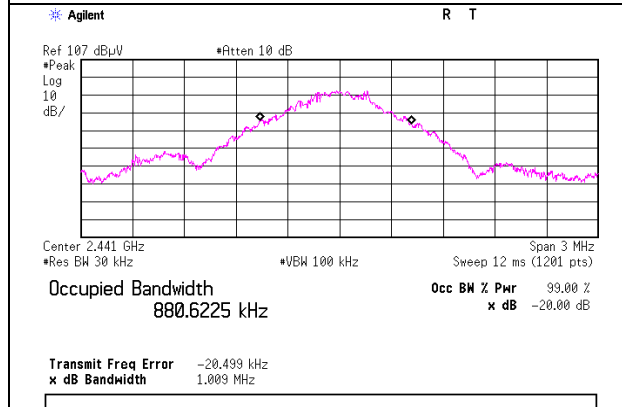

**2441MHz**

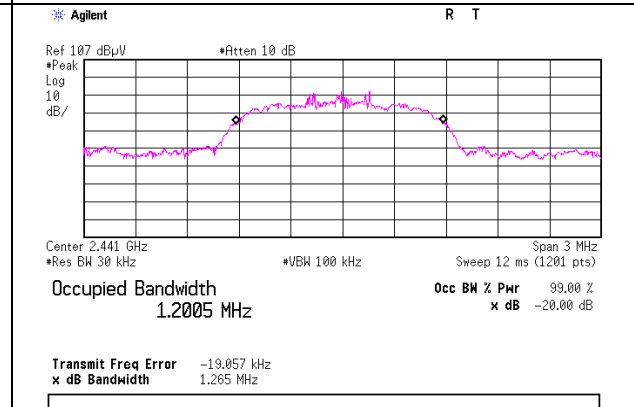

**2480MHz**

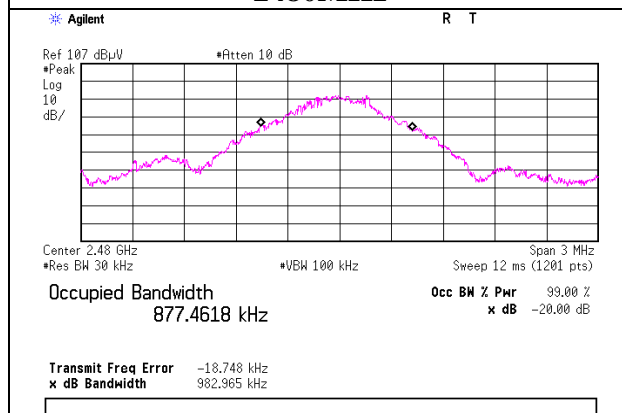

**2480MHz**

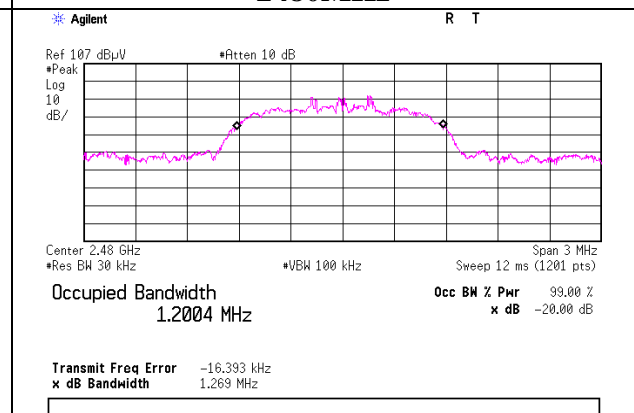



## 99% Occupied Bandwidth

### Model No. NR-244UH

Test place	Ise EMC Lab. No.06 Measurement Room
Report No.	10184498H
Date	01/15/2014
Temperature/ Humidity	21 deg.C/ 31% RH
Engineer	Masatoshi Nishiguchi
Mode	Tx (Hopping off) DH5/3DH5

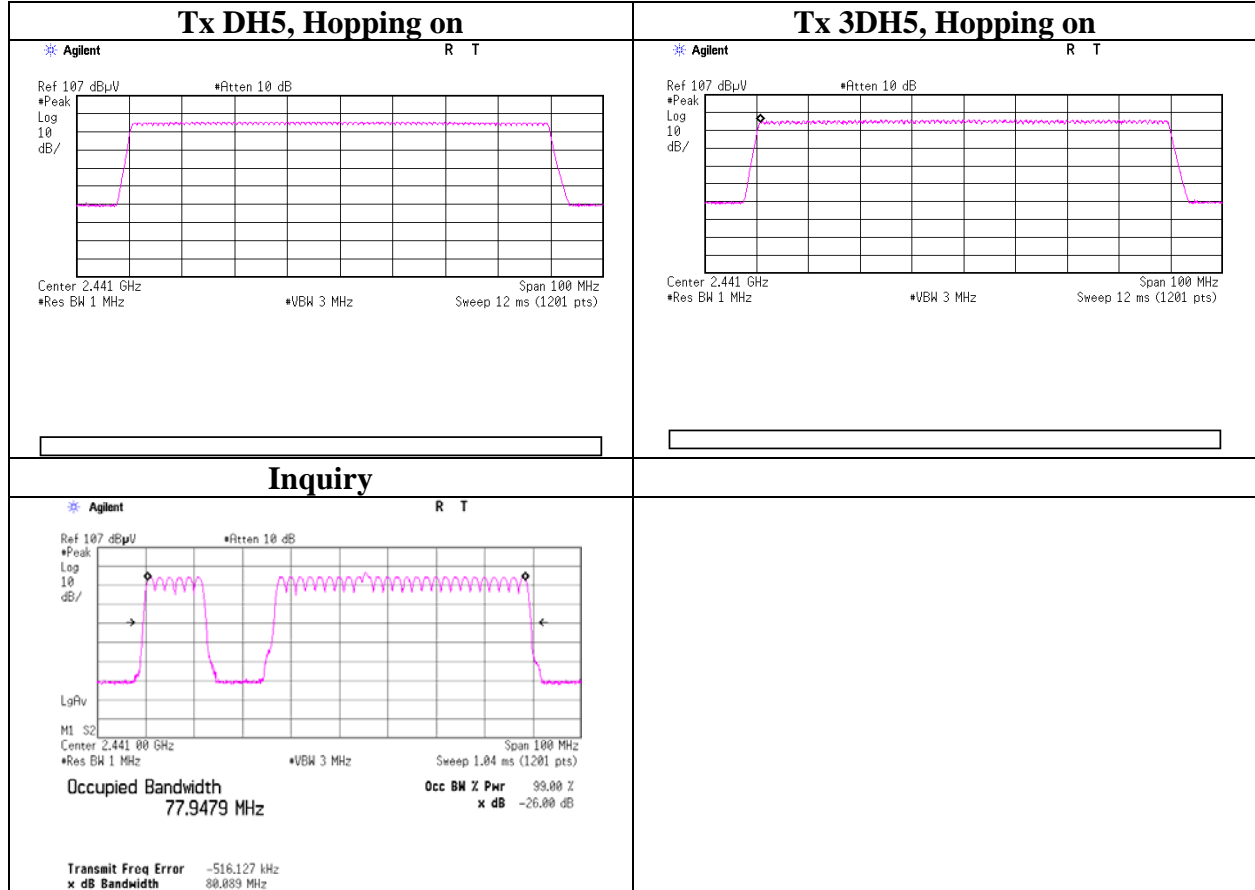

**UL Japan, Inc.**

**Ise EMC Lab.**

4383-326 Asama-cho, Ise-shi, Mie-ken 516-0021 JAPAN

Telephone : +81 596 24 8999

Facsimile : +81 596 24 8124

## **APPENDIX 2: Test instruments**

### **EMI test equipment**

Control No.	Instrument	Manufacturer	Model No	Serial No	Test Item	Calibration Date * Interval(month)
MAEC-02	Semi Anechoic Chamber(NSA)	TDK	Semi Anechoic Chamber 3m	DA-06902	RE	2013/06/30 * 12
MOS-22	Thermo-Hygrometer	Custom	CTH-201	0003	RE	2013/02/26 * 12
MJM-14	Measure	KOMELON	KMC-36	-	RE	-
COTS-MEMI	EMI measurement program	TSJ	TEPTO-DV	-	RE	-
MSA-04	Spectrum Analyzer	Agilent	E4448A	US44300523	RE	2013/11/25 * 12
MHA-06	Horn Antenna 1-18GHz	Schwarzbeck	BBHA9120D	254	RE	2013/02/15 * 12
MPA-10	Pre Amplifier	Agilent	8449B	3008A02142	RE	2014/01/21 * 12
MHF-06	High Pass Filter 3.5-24GHz	TOKIMEC	TF323DCA	601	RE	2013/05/30 * 12
MCC-166	Microwave Cable	Junkosha	MWX221	1303S120(1m) / 1311S167(5m)	RE	2013/11/27 * 12
MHA-02	Horn Antenna 18-26.5GHz	EMCO	3160-09	1265	RE	2013/02/15 * 12
MHF-16	High Pass Filter 7-20GHz	TOKIMEC	TF37NCCA	7001	RE	2013/09/25 * 12
MTR-03	Test Receiver	Rohde & Schwarz	ESCI	100300	RE	2013/06/11 * 12
MBA-02	Biconical Antenna	Schwarzbeck	BBA9106	VHA91032008	RE	2013/10/13 * 12
MLA-02	Logperiodic Antenna	Schwarzbeck	USLP9143	201	RE	2013/10/13 * 12
MCC-12	Coaxial Cable	Fujikura/Agilent	-	-	RE	2013/02/06 * 12
MAT-07	Attenuator(6dB)	Weinschel Corp	2	BK7970	RE	2013/11/26 * 12
MPA-09	Pre Amplifier	Agilent	8447D	2944A10845	RE	2013/09/12 * 12
MOS-14	Thermo-Hygrometer	Custom	CTH-201	-	AT	2013/02/26 * 12
MPM-12	Power Meter	Anritsu	ML2495A	0825002	AT	2013/06/12 * 12
MSA-06	Spectrum Analyzer	Agilent	E4407B	MY45107638	AT	2013/04/05 * 12
MAT-23	Attenuator(10dB) 1-18GHz	Orient Microwave	BX10-0476-00	-	AT	2013/03/21 * 12
MOS-15	Thermo-Hygrometer	Custom	CTH-180	-	AT	2013/02/26 * 12
MBM-03	Barometer	Sunoh	SBR121	595	AT	2012/02/23 * 36
MAT-23	Attenuator(10dB) 1-18GHz	Orient Microwave	BX10-0476-00	-	AT	2013/03/21 * 12
MCC-67	Microwave Cable 1G-40GHz	Suhner	SUCOFLEX102	28635/2	AT	2013/04/16 * 12
MCC-64	Coaxial Cable	UL Japan	-	-	AT	2013/03/22 * 12
MAT-10	Attenuator(10dB)	Weinschel Corp	2	BL1173	AT	2013/11/26 * 12

**The expiration date of the calibration is the end of the expired month.**

**All equipment is calibrated with valid calibrations. Each measurement data is traceable to the national or international standards.**

**As for some calibrations performed after the tested dates, those test equipment have been controlled by means of an unbroken chains of calibrations.**

**Test Item: RE: Radiated Emission**

**AT: Antenna Terminal Conducted test**

**UL Japan, Inc.**

**Ise EMC Lab.**

4383-326 Asama-cho, Ise-shi, Mie-ken 516-0021 JAPAN

Telephone : +81 596 24 8999

Facsimile : +81 596 24 8124