



RADIO TEST REPORT

Test Report No. : 10012781H-B

Applicant : Mitsubishi Electric Co.,Ltd
Type of Equipment : Navigation system
Model No. : NR-241
NR-241UH
NR-243UH
FCC ID : UJHNR241NR243
Test regulation : FCC Part 15 Subpart C: 2013
*WLAN Part
Test Result : Complied

1. This test report shall not be reproduced in full or partial, without the written approval of UL Japan, Inc.
2. The results in this report apply only to the sample tested.
3. This sample tested is in compliance with the above regulation.
4. The test results in this report are traceable to the national or international standards.
5. This test report must not be used by the customer to claim product certification, approval, or endorsement by NVLAP, NIST, or any agency of the Federal Government.

Date of test: May 21 to June 27, 2013

Representative test engineer:

Hiroshi Kukita
Engineer of WiSE Japan,
UL Verification Service

Approved by:

Masanori Nishiyama
Manager of WiSE Japan,
UL Verification Service



NVLAP LAB CODE: 200572-0

This laboratory is accredited by the NVLAP LAB CODE 200572-0, U.S.A. The tests reported herein have been performed in accordance with its terms of accreditation. *As for the range of Accreditation in NVLAP, you may refer to the WEB address, <http://www.ul.com/japan/jpn/pages/services/emc/about/mark1/index.jsp#nvlap>

UL Japan, Inc.

Head Office EMC Lab.

4383-326 Asama-cho, Ise-shi, Mie-ken 516-0021 JAPAN

Telephone : +81 596 24 8999

Facsimile : +81 596 24 8124

13-EM-F0429

CONTENTS	PAGE
SECTION 1: Customer information.....	4
SECTION 2: Equipment under test (E.U.T.).....	4
SECTION 3: Test specification, procedures & results.....	6
SECTION 4: Operation of E.U.T. during testing.....	9
SECTION 5: Radiated Spurious Emission	12
SECTION 6: Antenna Terminal Conducted Tests.....	13
APPENDIX 1: Data of EMI test.....	14
6dB Bandwidth	14
Maximum Peak Output Power	17
Radiated Spurious Emission	19
Conducted Spurious Emission	46
Power Density	47
99% Occupied Bandwidth	51
APPENDIX 2: Test instruments	53
APPENDIX 3: Photographs of test setup.....	55
Radiated Spurious Emission	55

SECTION 1: Customer information

Company Name : Mitsubishi Electric Co.,Ltd
Address : 2-3-33, Miwa, Sanda-city, Hyogo, 669-1513, Japan
Telephone Number : +81-79-559-3623
Facsimile Number : +81-79-559-3875
Contact Person : Kenji Otani

SECTION 2: Equipment under test (E.U.T.)

2.1 Identification of E.U.T.

Type of Equipment : Navigation System
Model No. : NR-241
NR-241UH
NR-243UH
Serial No. : Refer to Section 4, Clause 4.2
Rating : DC 13.2V
Receipt Date of Sample : May 14, 2013
Country of Mass-production : Thailand
Condition of EUT : Production prototype
(Not for Sale: This sample is equivalent to mass-produced items.)
Modification of EUT : No Modification by the test lab

2.2 Variant model

Model No. NR-241, NR-241UH, NR-243UH have variant models.
NR-241 has Left handle model and Right handle model.
NR-241UH and NR-243UH have Internal Amplifier model and External Amplifier model.
Above models were tested. Please refer to Section 4.1 for details.

UL Japan, Inc.

Head Office EMC Lab.

4383-326 Asama-cho, Ise-shi, Mie-ken 516-0021 JAPAN

Telephone : +81 596 24 8999

Facsimile : +81 596 24 8124

2.3 Product Description

General Specification

Clock frequency(ies) in the system : 800MHz

Radio Specification

[WLAN (IEEE802.11b/g/n-20)]

Radio Type : Transceiver
Frequency of Operation : 2412-2462MHz
Modulation : DSSS, OFDM
Power Supply (inner) : DC 3.3V
Antenna type : Inverted F Antenna
Antenna Gain : -1.89dBi

[Bluetooth (Ver. 3.0 with EDR function)]

Radio Type : Transceiver
Frequency of Operation : 2402-2480MHz
Modulation : FHSS
Power Supply (inner) : DC 3.3V
Antenna type : Inverted F Antenna
Antenna Gain : 0.40dBi

[GPS]

Radio Type : Receiver
Frequency of Operation : 1575.42MHz
Modulation : CDMA
Power Supply (radio part input) : DC 3.3V
Antenna type : Inverted F Antenna
Antenna Gain : 0dBi

*Co-location EMC tests were skipped based on FCC EMC co-location test policy of TCB workshop 2005 May, because it will be deemed that the compliance can be presumed under this filing condition by manufacturer declaration.

UL Japan, Inc.

Head Office EMC Lab.

4383-326 Asama-cho, Ise-shi, Mie-ken 516-0021 JAPAN

Telephone : +81 596 24 8999

Facsimile : +81 596 24 8124

SECTION 3: Test specification, procedures & results

3.1 Test Specification

Test Specification : FCC Part 15 Subpart C: 2013, final revised on June 11, 2013 and effective July 11, 2013

Title : FCC 47CFR Part15 Radio Frequency Device Subpart C Intentional Radiators
Section 15.207 Conducted limits
Section 15.247 Operation within the bands 902-928MHz,
2400-2483.5MHz, and 5725-5850MHz

* The revision on June 11, 2013 does not affect the test specification applied to the EUT.

3.2 Procedures and results

Item	Test Procedure	Specification	Worst margin	Results	Remarks
Conducted Emission	FCC: ANSI C63.4:2003 7. AC powerline Conducted Emission measurements ----- IC: RSS-Gen 7.2.4	FCC: Section 15.207 ----- IC: RSS-Gen 7.2.4	-	N/A	*1)
6dB Bandwidth	FCC: "Guidance for Performing Compliance Measurements on Digital Transmission Systems (DTS) Operating Under §15.247(issued on April 9, 2013)" ----- IC: RSS-Gen 4.6.2	FCC: Section 15.247(a)(2) ----- IC: RSS-210 A8.2(a)	See data.	Complied	Conducted
Maximum Peak Output Power	FCC: "Guidance for Performing Compliance Measurements on Digital Transmission Systems (DTS) Operating Under §15.247(issued on April 9, 2013)" ----- IC: RSS-Gen 4.8	FCC: Section 15.247(b)(3) ----- IC: RSS-210 A8.4(4)		Complied	Conducted
Power Density	FCC: "Guidance for Performing Compliance Measurements on Digital Transmission Systems (DTS) Operating Under §15.247(issued on April 9, 2013)" ----- IC: -	FCC: Section 15.247 (e) ----- IC: RSS-210 A8.2(b)		Complied	Conducted
Spurious Emission Restricted Band Edges	FCC: "Guidance for Performing Compliance Measurements on Digital Transmission Systems (DTS) Operating Under §15.247(issued on April 9, 2013)" ----- IC: RSS-Gen 4.9	FCC: Section15.247(d) ----- IC: RSS-210 A8.5 RSS-Gen 7.2.3	0.9dB 2483.5MHz, AV, Hori.	Complied	Conducted/ Radiated

Note: UL Japan, Inc.'s EMI Work Procedures No. 13-EM-W0420 and 13-EM-W0422.

*1) The test is not applicable since the EUT is not the device that is designed to be connected to the public utility (AC) power line.

* In case any questions arise about test procedure, ANSI C63.4: 2003 is also referred.

UL Japan, Inc.

Head Office EMC Lab.

4383-326 Asama-cho, Ise-shi, Mie-ken 516-0021 JAPAN

Telephone : +81 596 24 8999

Facsimile : +81 596 24 8124

FCC 15.31 (e)

The EUT is a battery-operated device and test was performed with the full-charged battery voltage. Therefore, this EUT complies with the requirement.

FCC Part 15.203 Antenna requirement

It is impossible for end users to replace the antenna, because the antenna is mounted inside of the EUT. Therefore, the equipment complies with the antenna requirement of Section 15.203.

3.3 Addition to standard

Item	Test Procedure	Specification	Worst margin	Results	Remarks
99% Occupied Bandwidth	IC: RSS-Gen 4.6.1	IC: RSS-Gen 4.6.1	N/A	-	Conducted

Other than above, no addition, exclusion nor deviation has been made from the standard.

3.4 Uncertainty

EMI

The following uncertainties have been calculated to provide a confidence level of 95% using a coverage factor k=2.

Test room (semi-anechoic chamber)	Radiated emission						
	(3m*)(+dB)				(1m*)(+dB)		(0.5m*)(+dB)
	9kHz -30MHz	30MHz -300MHz	300MHz -1GHz	1GHz -10GHz	10GHz -18GHz	18GHz -26.5GHz	26.5GHz -40GHz
No.1	4.3dB	5.0dB	5.1dB	4.9dB	5.8dB	4.4dB	4.3dB
No.2	4.3dB	5.2dB	5.1dB	5.0dB	5.7dB	4.3dB	4.2dB
No.3	4.6dB	5.0dB	5.1dB	5.0dB	5.7dB	4.5dB	4.2dB
No.4	4.8dB	5.2dB	5.0dB	5.0dB	5.7dB	5.2dB	4.2dB

*3m/1m/0.5m = Measurement distance

Power meter (+dB)	
Below 1GHz	Above 1GHz
0.7dB	1.5dB

Antenna terminal conducted emission and Power density (+dB)			Antenna terminal conducted emission (+dB)		Channel power (+dB)
Below 1GHz	1GHz-3GHz	3GHz-18GHz	18GHz-26.5GHz	26.5GHz-40GHz	
1.5dB	1.7dB	2.8dB	2.8dB	2.9dB	2.6dB

Radiated emission test(3m)

The data listed in this report meets the limits unless the uncertainty is taken into consideration.

UL Japan, Inc.

Head Office EMC Lab.

4383-326 Asama-cho, Ise-shi, Mie-ken 516-0021 JAPAN

Telephone : +81 596 24 8999

Facsimile : +81 596 24 8124

3.5 Test Location

UL Japan, Inc. Head Office EMC Lab. *NVLAP Lab. code: 200572-0
4383-326 Asama-cho, Ise-shi, Mie-ken 516-0021 JAPAN
Telephone : +81 596 24 8999 Facsimile : +81 596 24 8124

	FCC Registration Number	IC Registration Number	Width x Depth x Height (m)	Size of reference ground plane (m) / horizontal conducting plane	Other rooms
No.1 semi-anechoic chamber	313583	2973C-1	19.2 x 11.2 x 7.7m	7.0 x 6.0m	No.1 Power source room
No.2 semi-anechoic chamber	655103	2973C-2	7.5 x 5.8 x 5.2m	4.0 x 4.0m	-
No.3 semi-anechoic chamber	148738	2973C-3	12.0 x 8.5 x 5.9m	6.8 x 5.75m	No.3 Preparation room
No.3 shielded room	-	-	4.0 x 6.0 x 2.7m	N/A	-
No.4 semi-anechoic chamber	134570	2973C-4	12.0 x 8.5 x 5.9m	6.8 x 5.75m	No.4 Preparation room
No.4 shielded room	-	-	4.0 x 6.0 x 2.7m	N/A	-
No.5 semi-anechoic chamber	-	-	6.0 x 6.0 x 3.9m	6.0 x 6.0m	-
No.6 shielded room	-	-	4.0 x 4.5 x 2.7m	4.75 x 5.4 m	-
No.6 measurement room	-	-	4.75 x 5.4 x 3.0m	4.75 x 4.15 m	-
No.7 shielded room	-	-	4.7 x 7.5 x 2.7m	4.7 x 7.5m	-
No.8 measurement room	-	-	3.1 x 5.0 x 2.7m	N/A	-
No.9 measurement room	-	-	8.0 x 4.5 x 2.8m	2.0 x 2.0m	-
No.10 measurement room	-	-	2.6 x 2.8 x 2.5m	2.4 x 2.4m	-
No.11 measurement room	-	-	3.1 x 3.4 x 3.0m	2.4 x 3.4m	-

* Size of vertical conducting plane (for Conducted Emission test) : 2.0 x 2.0m for No.1, No.2, No.3, and No.4 semi-anechoic chambers and No.3 and No.4 shielded rooms.

3.6 Data of EMI, Test instruments, and Test set up

Refer to APPENDIX.

SECTION 4: Operation of E.U.T. during testing

4.1 Operating Mode(s)

Mode	Remarks*
IEEE 802.11b (11b)	2Mbps, PN9
IEEE 802.11g (11g)	12Mbps, PN9
IEEE 802.11n MIMO 20MHz BW (11n-20)	MCS 2 (GI: 800ns), PN9
*The worst condition was determined based on the test result of Maximum Peak Output Power (Mid Channel)	
*Power of the EUT was set by the software as follows; Power settings: IEEE 802.11b: +15dBm/22MHz IEEE 802.11g: +13dBm/20MHz IEEE 802.11n: +11dBm/20MHz Software: 1.0 *This setting of software is the worst case. Any conditions under the normal use do not exceed the condition of setting. In addition, end users cannot change the settings of the output power of the product.	

Details of tested models

	NR-241 (Left handle)	NR-241 (Right handle)	NR-243UH (Internal Amplifier)	NR-241UH (Internal Amplifier)	NR-241UH (External Amplifier)	NR-243UH (External Amplifier)
Antenna terminal conducted	X *1)	-	-	-	-	-
Spurious Emission (Radiated)	X 11b Tx 11n-20 Tx *2)	X 11n-20 Tx *3)	X 11b Tx 11n-20 Tx *2)	X 11b Tx 11n-20 Tx *4)	X 11n-20 Tx *3)	X 11n-20 Tx *3)

*1) The tests were performed with Model No. NR-241(Left handle) as a representative because the above models embedded same module.

*2) Since 11g and 11n-20 have the same modulation method and no differences in transmitting specification, test was performed on the representative mode that had the higher peak output power.

*3) The test was performed on the mode that has the worst condition in model No.: NR-241(Left handle) according to the customer's request.

*4) The test was performed on the mode that has the worst condition in model No.: NR-243UH (Internal Amplifier) according to the customer's request.

UL Japan, Inc.

Head Office EMC Lab.

4383-326 Asama-cho, Ise-shi, Mie-ken 516-0021 JAPAN

Telephone : +81 596 24 8999

Facsimile : +81 596 24 8124

4.2 Configuration and peripherals

[Model No.: NR-241 (Left handle), NR-241 (Right handle), NR-243UH (Internal Amplifier), NR-241UH (Internal Amplifier)]

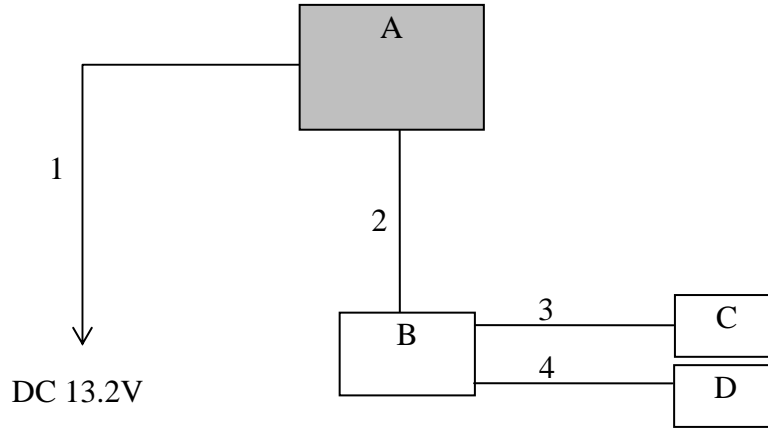

[Model No.: NR-241UH4CC50-T (External Amplifier), NR-243UH4CCF0-T (External Amplifier)]

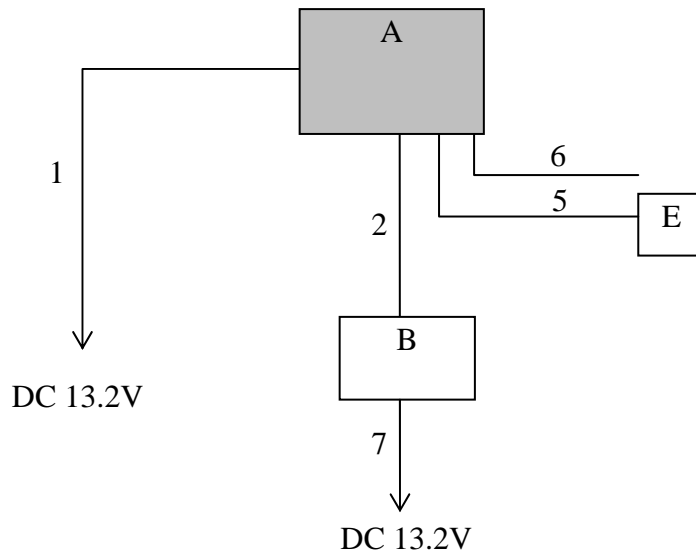

* Cabling and setup were taken into consideration and test data was taken under worse case conditions.

UL Japan, Inc.

Head Office EMC Lab.

4383-326 Asama-cho, Ise-shi, Mie-ken 516-0021 JAPAN

Telephone : +81 596 24 8999

Facsimile : +81 596 24 8124

Description of EUT

No.	Item	Model number	Serial number	Manufacturer	Remark
A	Navigation System	NR-241 (Left handle)	934H6012 *1) 934H6009 *2)	Mitsubishi Electric Co.,Ltd	EUT
		NR-241 (Right handle)	935B6001		
		NR-243UH (Internal Amplifier)	93527045		
		NR-241UH (Internal Amplifier)	934R7039		
		NR-241UH (External Amplifier)	934R7009		
		NR-243UH (External Amplifier)	934Q7003		
B	Jig board	-	-	-	-
C	Speaker	TS-STX5		PIONEER	-
D	Speaker	TS-STX5	FM0847	PIONEER	-
E	GPS Antenna	-	-	-	-

*1) Used for Radiated Spurious Emission test

*2) Used for Antenna Terminal Conducted tests

List of cables used

No.	Name	Length (m)	Shield	
			Cable	Connector
1	DC Cable	3.3	Unshielded	Unshielded
2	Signal Cable	1.8	Unshielded	Unshielded
3	Speaker Cable	0.5	Unshielded	Unshielded
4	Speaker Cable	0.5	Unshielded	Unshielded
5	Antenna Cable	3.0	Shielded	Shielded
6	Signal Cable	2.0	Unshielded	Unshielded
7	DC Cable	2.0	Unshielded	Unshielded

UL Japan, Inc.

Head Office EMC Lab.

4383-326 Asama-cho, Ise-shi, Mie-ken 516-0021 JAPAN

Telephone : +81 596 24 8999

Facsimile : +81 596 24 8124

SECTION 5: Radiated Spurious Emission

Test Procedure

It was measured based on "11.0 Emissions in non-restricted frequency bands" of "Guidance for Performing Compliance Measurements on Digital Transmission Systems (DTS) Operating Under §15.247 (Issued on April 9, 2013)".

EUT was placed on a urethane platform of nominal size, 1.0m by 1.5m, raised 0.8m above the conducting ground plane.

The Radiated Electric Field Strength has been measured in a Semi Anechoic Chamber with a ground plane.

The height of the measuring antenna varied between 1 and 4m and EUT was rotated a full revolution in order to obtain the maximum value of the electric field strength.

The measurements were performed for both vertical and horizontal antenna polarization with the Test Receiver, or the Spectrum Analyzer.

The measurements were made with the following detector function of the test receiver and the Spectrum analyzer (in linear mode).

The test was made with the detector (RBW/VBW) in the following table.

When using Spectrum analyzer, the test was made with adjusting span to zero by using peak hold.

Test Antennas are used as below;

Frequency	Below 30MHz	30MHz to 300MHz	300MHz to 1GHz	Above 1GHz
Antenna Type	Loop	Biconical	Logperiodic	Horn

In any 100kHz bandwidth outside the restricted band in which the spread spectrum intentional radiator is operating, the radio frequency power that is produced by the intentional radiator confirmed 20dB below that in the 100kHz bandwidth within the band that contains the highest level of the desired power, based on a radiated measurement.

20dBc was applied to the frequency over the limit of FCC 15.209 / Table 5 of RSS-Gen 7.2.5(IC) and outside the restricted band of FCC15.205 / Table 3 of RSS-Gen 7.2.2 (IC).

Frequency	Below 1GHz	Above 1GHz		20dBc
Instrument used	Test Receiver	Spectrum Analyzer		Spectrum Analyzer
Detector	QP	PK	AV	PK
IF Bandwidth	BW 120kHz(T/R)	RBW: 1MHz VBW: 3MHz	Average Power Method: Alternative 1 *2) RBW: 1MHz VBW: 3MHz Detector: Power Averaging (RMS) Trace: Free Run Duty factor was added to the results.	RBW: 100kHz VBW: 300kHz (S/A)
Test Distance	3m	3m (below 10GHz), 1m *1) (above 10GHz)		3m (below 10GHz), 1m *1) (above 10GHz)

*1) Distance Factor: $20 \times \log(3.0\text{m}/1.0\text{m}) = 9.5\text{dB}$

*2) Average Power Measurement was performed based on 6.0 & 12.2.5 of "Guidance for Performing Compliance Measurements on Digital Transmission Systems (DTS) Operating Under §15.247 (Issued on April 9, 2013)"

The test was made on EUT at the normal use position.

The test results and limit are rounded off to one decimal place, so some differences might be observed.

Measurement range : 30M-26.5GHz
Test data : APPENDIX
Test result : Pass

UL Japan, Inc.

Head Office EMC Lab.

4383-326 Asama-cho, Ise-shi, Mie-ken 516-0021 JAPAN

Telephone : +81 596 24 8999

Facsimile : +81 596 24 8124

SECTION 6: Antenna Terminal Conducted Tests

Test Procedure

The tests were made with below setting connected to the antenna port.

Test	Span	RBW	VBW	Sweep time	Detector	Trace	Instrument used
6dB Bandwidth	30MHz	100kHz	300kHz	Auto	Peak	Max Hold	Spectrum Analyzer
99% Occupied Bandwidth	Enough width to display 20dB Bandwidth	1 to 3% of Span	Three times of RBW	Auto	Peak	Max Hold *1)	Spectrum Analyzer
Maximum Peak Output Power	-	-	-	Auto	Peak	-	Power Meter (Sensor: 50MHz BW)
Peak Power Density	1.5 times the 6dB Bandwidth	3kHz	9.1kHz	Auto	Peak	Max Hold	Spectrum Analyzer *2)
Conducted Spurious Emission *3)	9kHz to 150kHz	200Hz	620Hz	Auto	Peak	Max Hold	Spectrum Analyzer
	150kHz to 30MHz	9.1kHz	27kHz				

*1) The measurement was performed with Max Hold since the duty cycle was not 100%.

*2) Section 10.2 Method PKPSD (peak PSD) of "Guidance for Performing Compliance Measurements on Digital Transmission Systems (DTS) Operating Under §15.247 (Issued on April 9, 2013)".

*3) In the frequency range below 30MHz, RBW was narrowed to separate the noise contents.

Then, wide-band noise near the limit was checked separately, however the noise was not detected as shown in the chart.(9kHz-150kHz:RBW=200Hz, 150kHz-30MHz:RBW=9.1kHz)

The test results and limit are rounded off to two decimals place, so some differences might be observed.

Test data : APPENDIX
Test result : Pass

UL Japan, Inc.

Head Office EMC Lab.

4383-326 Asama-cho, Ise-shi, Mie-ken 516-0021 JAPAN

Telephone : +81 596 24 8999

Facsimile : +81 596 24 8124

6dB Bandwidth

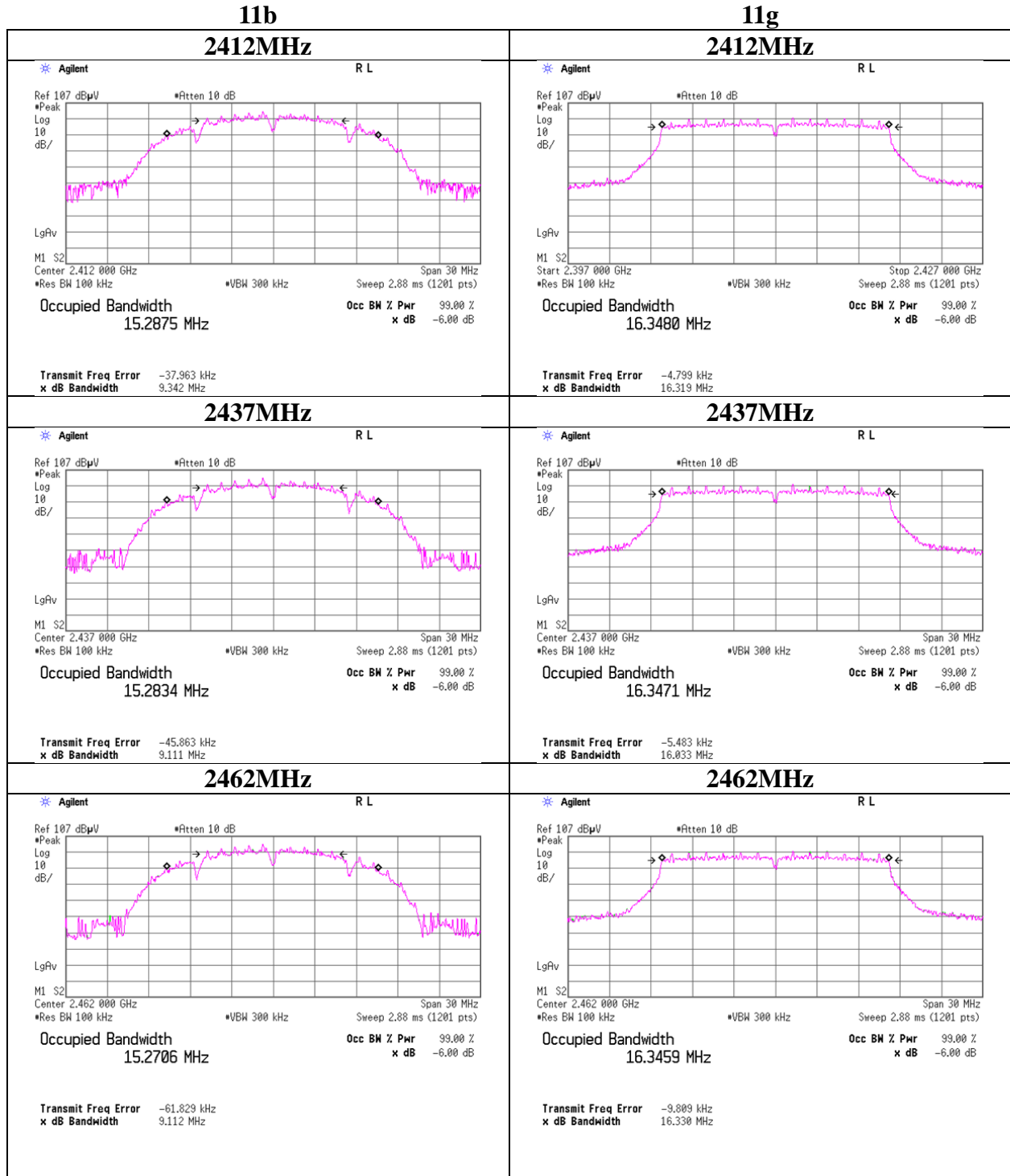

6dB Bandwidth

11n-20 (GI=800ns)

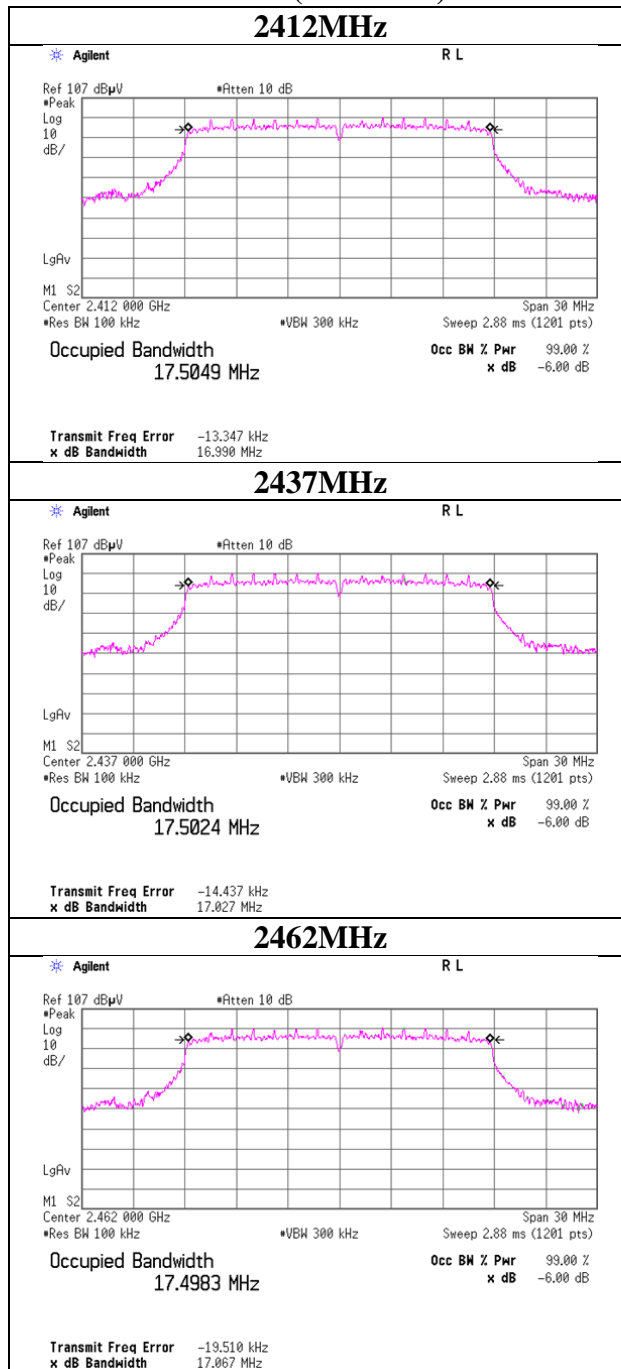

UL Japan, Inc.

Head Office EMC Lab.

4383-326 Asama-cho, Ise-shi, Mie-ken 516-0021 JAPAN

Telephone : +81 596 24 8999

Facsimile : +81 596 24 8124

Maximum Peak Output Power

Test place Head Office EMC Lab. No.11 Measurement Room
Report No. 10012781H
Date 05/23/2013 05/21/2013
Temperature/ Humidity 24 deg. C / 40% RH 23 deg. C / 48% RH
Engineer Kazuya Yoshioka Kazuya Yoshioka
Mode 11b / 11g Tx

11b

Freq. [MHz]	Reading [dBm]	Cable Loss [dB]	Atten. [dB]	Result		Limit		Margin [dB]
				[dBm]	[mW]	[dBm]	[mW]	
2412	6.45	0.50	10.01	16.96	49.66	30.00	1000	13.04
2437	6.54	0.50	10.01	17.05	50.70	30.00	1000	12.95
2462	6.62	0.50	10.01	17.13	51.64	30.00	1000	12.87

11g

Freq. [MHz]	Reading [dBm]	Cable Loss [dB]	Atten. [dB]	Result		Limit		Margin [dB]
				[dBm]	[mW]	[dBm]	[mW]	
2412	10.65	0.50	10.01	21.16	130.62	30.00	1000	8.84
2437	10.99	0.50	10.01	21.50	141.25	30.00	1000	8.50
2462	10.77	0.50	10.01	21.28	134.28	30.00	1000	8.72

Sample Calculation:

Result = Reading + Cable Loss (including the cable(s) customer supplied) + Attenuator

11b , 2437MHz

Rate [Mbps]	Reading [dBm]	Remark
1	6.46	
2	6.54	*
5.5	6.50	
11	6.52	

11g , 2437MHz

Rate [Mbps]	Reading [dBm]	Remark
6	10.94	
9	10.75	
12	10.99	*
18	10.78	
24	10.80	
36	10.73	
48	10.80	
54	10.89	

*: Worst Rate

All comparizon were carried out on same frequency and measurement factors.

UL Japan, Inc.

Head Office EMC Lab.

4383-326 Asama-cho, Ise-shi, Mie-ken 516-0021 JAPAN

Telephone : +81 596 24 8999

Facsimile : +81 596 24 8124

Maximum Peak Output Power

Test place	Head Office EMC Lab. No.11 Measurement Room
Report No.	10012781H
Date	05/23/2013
Temperature/ Humidity	24 deg. C / 40% RH
Engineer	Kazuya Yoshioka
Mode	11n-20 Tx

11n-20

Freq. [MHz]	Reading [dBm]	Cable Loss [dB]	Atten. [dB]	Result		Limit		Margin [dB]
				[dBm]	[mW]	[dBm]	[mW]	
2412	11.02	0.50	10.01	21.53	142.23	30.00	1000	8.47
2437	11.09	0.50	10.01	21.60	144.54	30.00	1000	8.40
2462	10.95	0.50	10.01	21.46	139.96	30.00	1000	8.54

Sample Calculation:

Result = Reading + Cable Loss (including the cable(s) customer supplied) + Attenuator

11n-20 , 2437MHz

Rate [MCS]	Guard Interval	Reading [dBm]	Remark
0	Long	10.94	
1	Long	10.87	
2	Long	11.09	*
3	Long	10.63	
4	Long	10.58	
5	Long	9.57	
6	Long	10.18	
7	Long	9.84	
0	Short	10.99	
1	Short	10.79	
2	Short	11.02	
3	Short	10.77	
4	Short	10.69	
5	Short	9.56	
6	Short	10.23	
7	Short	10.02	

*: Worst Rate

All comparizon were carried out on same frequency and measurement factors.

UL Japan, Inc.

Head Office EMC Lab.

4383-326 Asama-cho, Ise-shi, Mie-ken 516-0021 JAPAN

Telephone : +81 596 24 8999

Facsimile : +81 596 24 8124

Radiated Spurious Emission
(NR-241 (Left handle))

Test place Head Office EMC Lab. No.2 Semi Anechoic Chamber
Report No. 10012781H
Date 05/23/2013
Temperature/ Humidity 23 deg. C / 56% RH
Engineer Hiroshi Kukita
(1-26.5GHz)
Mode 11b Tx 2412MHz

Polarity	Frequency [MHz]	Detector	Reading [dBuV]	Ant.Fac. [dB/m]	Loss [dB]	Gain [dB]	Result [dBuV/m]	Limit [dBuV/m]	Margin [dB]	Remark
Hori	2390.000	PK	68.3	26.8	2.4	35.7	61.8	73.9	12.1	
Hori	3334.963	PK	47.5	27.9	15.8	35.0	56.2	73.9	17.7	
Hori	4824.000	PK	46.7	30.7	4.3	34.9	46.8	73.9	27.1	
Hori	7236.000	PK	48.5	35.6	4.9	34.9	54.1	73.9	19.8	
Hori	9648.000	PK	45.2	38.2	5.7	35.4	53.7	73.9	20.2	
Hori	2390.000	AV	52.1	26.8	2.4	35.7	45.6	53.9	8.3	
Hori	3334.963	AV	39.2	27.9	15.8	35.0	47.9	53.9	6.0	
Hori	4824.000	AV	40.0	30.7	4.3	34.9	40.1	53.9	13.8	
Hori	7236.000	AV	39.9	35.6	4.9	34.9	45.5	53.9	8.4	
Hori	9648.000	AV	39.2	38.2	5.7	35.4	47.7	53.9	6.2	
Vert	2390.000	PK	61.6	26.8	2.4	35.7	55.1	73.9	18.8	
Vert	3332.042	PK	49.9	27.9	2.8	35.0	45.6	73.9	28.3	
Vert	4824.000	PK	49.7	30.7	4.3	34.9	49.8	73.9	24.1	
Vert	7236.000	PK	45.7	35.6	4.9	34.9	51.3	73.9	22.6	
Vert	9648.000	PK	46.1	38.2	5.7	35.4	54.6	73.9	19.3	
Vert	2390.000	AV	48.4	26.8	2.4	35.7	41.9	53.9	12.0	
Vert	3332.042	AV	40.3	27.9	2.8	35.0	36.0	53.9	17.9	
Vert	4824.000	AV	46.4	30.7	4.3	34.9	46.5	53.9	7.4	
Vert	7236.000	AV	39.7	35.6	4.9	34.9	45.3	53.9	8.6	
Vert	9648.000	AV	39.5	38.2	5.7	35.4	48.0	53.9	5.9	

Result = Reading + Ant Factor + Loss (Cable+Attenuator+Filter-Distance factor(above 10GHz)) - Gain(Amplifier)

*Other frequency noises omitted in this report were not seen or had enough margin (more than 20dB).

Distance factor: 10GHz-26.5GHz 20log(3.0m/1.0m)= 9.5dB

20dBc Data Sheet

Polarity	Frequency [MHz]	Detector	Reading [dBuV]	Ant Factor [dB/m]	Loss [dB]	Gain [dB]	Result [dBuV/m]	Limit [dBuV/m]	Margin [dB]	Remark
Hori	2412.000	PK	110.1	26.8	2.4	35.7	103.6	-	-	Carrier
Hori	2400.000	PK	64.4	26.8	2.4	35.7	57.9	83.6	25.7	
Vert	2412.000	PK	103.8	26.8	2.4	35.7	97.3	-	-	Carrier
Vert	2400.000	PK	58.0	26.8	2.4	35.7	51.5	77.3	25.8	

Result = Reading + Ant Factor + Loss (Cable+Attenuator+Filter-Distance factor(above 10GHz)) - Gain(Amplifier)

UL Japan, Inc.

Head Office EMC Lab.

4383-326 Asama-cho, Ise-shi, Mie-ken 516-0021 JAPAN

Telephone : +81 596 24 8999

Facsimile : +81 596 24 8124

Radiated Spurious Emission
(NR-241 (Left handle))

Test place : Head Office EMC Lab. No.2 Semi Anechoic Chamber
Report No. : 10012781H
Date : 05/23/2013
Temperature/ Humidity : 23 deg. C / 56% RH
Engineer : Hiroshi Kukita
(1-26.5GHz)
Mode : 11b Tx 2437MHz

Polarity	Frequency [MHz]	Detector	Reading [dBuV]	Ant.Fac. [dB/m]	Loss [dB]	Gain [dB]	Result [dBuV/m]	Limit [dBuV/m]	Margin [dB]	Remark
Hori	3337.950	PK	49.7	27.9	2.8	35.0	45.4	73.9	28.5	
Hori	4874.000	PK	47.4	30.8	4.2	34.9	47.5	73.9	26.4	
Hori	7311.000	PK	40.9	35.7	4.9	34.9	46.6	73.9	27.3	
Hori	9748.000	PK	42.5	38.4	5.7	35.4	51.2	73.9	22.7	
Hori	3337.950	AV	40.0	27.9	2.8	35.0	35.7	53.9	18.2	
Hori	4874.000	AV	40.9	30.8	4.2	34.9	41.0	53.9	12.9	
Hori	7311.000	AV	34.5	35.7	4.9	34.9	40.2	53.9	13.7	
Hori	9748.000	AV	35.1	38.4	5.7	35.4	43.8	53.9	10.1	
Vert	3262.182	PK	47.1	27.9	2.8	35.0	42.8	73.9	31.1	
Vert	4874.000	PK	46.9	30.8	4.2	34.9	47.0	73.9	26.9	
Vert	7311.000	PK	40.6	35.7	4.9	34.9	46.3	73.9	27.6	
Vert	9748.000	PK	39.8	38.4	5.7	35.4	48.5	73.9	25.4	
Vert	3262.182	AV	35.6	27.9	2.8	35.0	31.3	53.9	22.6	
Vert	4874.000	AV	41.2	30.8	4.2	34.9	41.3	53.9	12.6	
Vert	7311.000	AV	33.7	35.7	4.9	34.9	39.4	53.9	14.5	
Vert	9748.000	AV	33.6	38.4	5.7	35.4	42.3	53.9	11.6	

Result = Reading + Ant Factor + Loss (Cable+Attenuator+Filter-Distance factor(above 10GHz)) - Gain(Amplifier)

*Other frequency noises omitted in this report were not seen or had enough margin (more than 20dB).

Distance factor: 10GHz-26.5GHz 20log(3.0m/1.0m)= 9.5dB

UL Japan, Inc.

Head Office EMC Lab.

4383-326 Asama-cho, Ise-shi, Mie-ken 516-0021 JAPAN

Telephone : +81 596 24 8999

Facsimile : +81 596 24 8124

Radiated Spurious Emission
(NR-241 (Left handle))

Test place Head Office EMC Lab. No.2 Semi Anechoic Chamber
Report No. 10012781H
Date 05/23/2013
Temperature/ Humidity 23 deg. C / 56% RH
Engineer Hiroshi Kukita
(1-26.5GHz)
Mode 11b Tx 2462MHz

Polarity	Frequency [MHz]	Detector	Reading [dBuV]	Ant.Fac. [dB/m]	Loss [dB]	Gain [dB]	Result [dBuV/m]	Limit [dBuV/m]	Margin [dB]	Remark
Hori	2483.500	PK	67.8	26.7	2.4	35.7	61.2	73.9	12.7	
Hori	3332.362	PK	53.8	27.9	16.0	35.0	62.7	73.9	11.2	
Hori	4924.000	PK	52.9	31.0	4.2	34.9	53.2	73.9	20.7	
Hori	7386.000	PK	43.4	35.8	4.4	34.9	48.7	73.9	25.2	
Hori	9848.000	PK	40.9	38.6	5.8	35.4	49.9	73.9	24.0	
Hori	2483.500	AV	53.8	26.7	2.4	35.7	47.2	53.9	6.7	
Hori	3332.362	AV	40.4	27.9	16.0	35.0	49.3	53.9	4.6	
Hori	4924.000	AV	49.8	31.0	4.2	34.9	50.1	53.9	3.8	
Hori	7386.000	AV	34.8	35.8	5.0	34.9	40.7	53.9	13.2	
Hori	9848.000	AV	35.2	38.6	5.8	35.4	44.2	53.9	9.7	
Vert	2483.500	PK	60.9	26.7	2.4	35.7	54.3	73.9	19.6	
Vert	3263.856	PK	47.6	27.9	2.8	35.0	43.3	73.9	30.6	
Vert	4924.000	PK	46.5	31.0	4.2	34.9	46.8	73.9	27.1	
Vert	7386.000	PK	40.5	35.8	5.0	34.9	46.4	73.9	27.5	
Vert	9848.000	PK	40.6	38.6	5.8	35.4	49.6	73.9	24.3	
Vert	2483.500	AV	47.9	26.7	2.4	35.7	41.3	53.9	12.6	
Vert	3263.856	AV	35.6	27.9	2.8	35.0	31.3	53.9	22.6	
Vert	4924.000	AV	40.0	31.0	4.2	34.9	40.3	53.9	13.6	
Vert	7386.000	AV	34.8	35.8	5.0	34.9	40.7	53.9	13.2	
Vert	9848.000	AV	35.4	38.6	5.8	35.4	44.4	53.9	9.5	

Result = Reading + Ant Factor + Loss (Cable+Attenuator+Filter-Distance factor(above 10GHz)) - Gain(Amplifier)

*Other frequency noises omitted in this report were not seen or had enough margin (more than 20dB).

Distance factor: 10GHz-26.5GHz 20log(3.0m/1.0m)= 9.5dB

UL Japan, Inc.

Head Office EMC Lab.

4383-326 Asama-cho, Ise-shi, Mie-ken 516-0021 JAPAN

Telephone : +81 596 24 8999

Facsimile : +81 596 24 8124

Radiated Spurious Emission
(NR-241 (Left handle))

Test place Head Office EMC Lab. No.2 Semi Anechoic Chamber
Report No. 10012781H
Date 05/23/2013
Temperature/ Humidity 23 deg. C / 56% RH
Engineer Hiroshi Kukita
(1-26.5GHz)
Mode 11n-20 Tx 2412MHz

Polarity	Frequency [MHz]	Detector	Reading [dBuV]	Ant.Fac. [dB/m]	Loss [dB]	Gain [dB]	Duty Factor [dB]	Result [dBuV/m]	Limit [dBuV/m]	Margin [dB]	Remark
Hori	2390.000	PK	69.7	26.8	2.4	35.7	-	63.2	73.9	10.7	
Hori	3263.780	PK	45.2	27.9	2.8	35.0	-	40.9	73.9	33.0	
Hori	4824.000	PK	43.5	30.7	4.3	34.9	-	43.6	73.9	30.3	
Hori	7236.000	PK	45.1	35.6	4.9	34.9	-	50.7	73.9	23.2	
Hori	9648.000	PK	43.3	38.2	5.7	35.4	-	51.8	73.9	22.1	
Hori	2390.000	AV	58.0	26.8	2.4	35.7	0.1	51.6	53.9	2.3	Not Out of band emission(Leakage Power)
Hori	3263.780	AV	35.5	27.9	2.8	35.0	0.1	31.3	53.9	22.6	
Hori	4824.000	AV	32.4	30.7	4.3	34.9	0.1	32.6	53.9	21.3	
Hori	7236.000	AV	37.0	35.6	4.9	34.9	0.1	42.7	53.9	11.2	
Hori	9648.000	AV	37.8	38.2	5.7	35.4	0.1	46.4	53.9	7.5	
Vert	2390.000	PK	49.6	26.8	2.4	35.7	-	43.1	73.9	30.8	
Vert	2994.994	PK	43.4	27.6	2.7	35.2	-	38.5	73.9	35.4	
Vert	4824.000	PK	44.8	30.7	4.3	34.9	-	44.9	73.9	29.0	
Vert	7236.000	PK	47.0	35.6	4.9	34.9	-	52.6	73.9	21.3	
Vert	9648.000	PK	45.1	38.2	5.7	35.4	-	53.6	73.9	20.3	
Vert	2390.000	AV	42.5	26.8	2.4	35.7	0.1	36.1	53.9	17.8	Not Out of band emission(Leakage Power)
Vert	2994.994	AV	33.9	27.6	2.7	35.2	0.1	29.1	53.9	24.8	
Vert	4824.000	AV	35.5	30.7	4.3	34.9	0.1	35.7	53.9	18.2	
Vert	7236.000	AV	38.0	35.6	4.9	34.9	0.1	43.7	53.9	10.2	
Vert	9648.000	AV	37.8	38.2	5.7	35.4	0.1	46.4	53.9	7.5	

Result = Reading + Ant Factor + Loss (Cable+Attenuator+Filter-Distance factor(above 10GHz)) - Gain(Amplifier) + Duty Factor(AV)

*Other frequency noises omitted in this report were not seen or had enough margin (more than 20dB).

Distance factor: 10GHz-26.5GHz 20log(3.0m/1.0m)= 9.5dB

20dBc Data Sheet

Polarity	Frequency [MHz]	Detector	Reading [dBuV]	Ant Factor [dB/m]	Loss [dB]	Gain [dB]	Result [dBuV/m]	Limit [dBuV/m]	Margin [dB]	Remark
Hori	2412.000	PK	105.7	26.8	2.4	35.7	99.2	-	-	Carrier
Hori	2400.000	PK	67.5	26.8	2.4	35.7	61.0	79.2	18.2	
Vert	2412.000	PK	99.1	26.8	2.4	35.7	92.6	-	-	Carrier
Vert	2400.000	PK	47.8	26.8	2.4	35.7	41.3	72.6	31.3	

Result = Reading + Ant Factor + Loss (Cable+Attenuator+Filter-Distance factor(above 10GHz)) - Gain(Amplifier)

UL Japan, Inc.

Head Office EMC Lab.

4383-326 Asama-cho, Ise-shi, Mie-ken 516-0021 JAPAN

Telephone : +81 596 24 8999

Facsimile : +81 596 24 8124

Radiated Spurious Emission
(NR-241 (Left handle))

Test place Head Office EMC Lab. No.2 Semi Anechoic Chamber
Report No. 10012781H
Date 05/23/2013 05/24/2013
Temperature/ Humidity 23 deg. C / 56% RH 20 deg. C / 46% RH
Engineer Hiroshi Kukita Kazuya Yoshioka
(1-26.5GHz) (30-1000MHz)
Mode 11n-20 Tx 2437MHz

Polarity	Frequency [MHz]	Detector	Reading [dBuV]	Ant.Fac. [dB/m]	Loss [dB]	Gain [dB]	Duty Factor [dB]	Result [dBuV/m]	Limit [dBuV/m]	Margin [dB]	Remark
Hori	33.275	QP	22.8	16.7	6.8	28.6	-	17.7	40.0	22.3	
Hori	55.753	QP	23.1	9.1	7.0	28.6	-	10.6	40.0	29.4	
Hori	110.994	QP	28.4	11.7	7.6	28.3	-	19.4	43.5	24.1	
Hori	200.190	QP	21.8	16.6	8.1	27.8	-	18.7	43.5	24.8	
Hori	400.015	QP	23.1	17.4	9.3	28.4	-	21.4	46.0	24.6	
Hori	500.025	QP	23.0	18.0	9.8	28.8	-	22.0	46.0	24.0	
Hori	3263.348	PK	43.3	27.9	22.4	35.0	-	58.6	73.9	15.3	
Hori	4874.000	PK	41.0	30.8	4.2	34.9	-	41.1	73.9	32.8	
Hori	7311.000	PK	40.0	35.7	4.9	34.9	-	45.7	73.9	28.2	
Hori	9748.000	PK	40.8	38.4	5.7	35.4	-	49.5	73.9	24.4	
Hori	3263.348	AV	35.3	27.9	22.4	35.0	0.1	50.7	53.9	3.2	
Hori	4874.000	AV	33.4	30.8	4.2	34.9	0.1	33.6	53.9	20.3	
Hori	7311.000	AV	33.4	35.7	4.9	34.9	0.1	39.2	53.9	14.7	
Hori	9748.000	AV	34.6	38.4	5.7	35.4	0.1	43.4	53.9	10.5	
Vert	33.265	QP	30.8	16.7	6.8	28.6	-	25.7	40.0	14.3	
Vert	55.451	QP	25.7	9.2	7.0	28.6	-	13.3	40.0	26.7	
Vert	110.998	QP	25.6	11.7	7.6	28.3	-	16.6	43.5	26.9	
Vert	200.198	QP	21.8	16.6	8.1	27.8	-	18.7	43.5	24.8	
Vert	400.021	QP	23.1	17.4	9.3	28.4	-	21.4	46.0	24.6	
Vert	500.031	QP	23.0	18.0	9.8	28.8	-	22.0	46.0	24.0	
Vert	2873.447	PK	49.2	27.4	2.6	35.3	-	43.9	73.9	30.0	
Vert	4874.000	PK	40.6	30.8	4.2	34.9	-	40.7	73.9	33.2	
Vert	7311.000	PK	40.6	35.7	4.9	34.9	-	46.3	73.9	27.6	
Vert	9748.000	PK	41.6	38.4	5.7	35.4	-	50.3	73.9	23.6	
Vert	2873.447	AV	34.5	27.4	2.6	35.3	0.1	29.3	53.9	24.6	
Vert	4874.000	AV	34.0	30.8	4.2	34.9	0.1	34.2	53.9	19.7	
Vert	7311.000	AV	33.3	35.7	4.9	34.9	0.1	39.1	53.9	14.8	
Vert	9748.000	AV	33.6	38.4	5.7	35.4	0.1	42.4	53.9	11.5	

Result = Reading + Ant Factor + Loss (Cable+Attenuator+Filter-Distance factor(above 10GHz)) - Gain(Amplifier) + Duty Factor(AV)

*Other frequency noises omitted in this report were not seen or had enough margin (more than 20dB).

Distance factor: 10GHz-26.5GHz 20log(3.0m/1.0m)= 9.5dB

Radiated Spurious Emission
(NR-241 (Left handle))

Test place Head Office EMC Lab. No.2 Semi Anechoic Chamber
Report No. 10012781H
Date 05/23/2013
Temperature/ Humidity 23 deg. C / 56% RH
Engineer Hiroshi Kukita
(1-26.5GHz)
Mode 11n-20 Tx 2462MHz

Polarity	Frequency [MHz]	Detector	Reading [dBuV]	Ant.Fac. [dB/m]	Loss [dB]	Gain [dB]	Duty Factor [dB]	Result [dBuV/m]	Limit [dBuV/m]	Margin [dB]	Remark
Hori	2483.500	PK	70.0	26.7	2.4	35.7	-	63.4	73.9	10.5	
Hori	2809.418	PK	53.4	27.3	2.6	35.4	-	47.9	73.9	26.0	
Hori	4924.000	PK	47.9	31.0	4.2	34.9	-	48.2	73.9	25.7	
Hori	7386.000	PK	49.6	35.8	5.0	34.9	-	55.5	73.9	18.4	
Hori	9848.000	PK	45.4	38.6	5.8	35.4	-	54.4	73.9	19.5	
Hori	2483.500	AV	59.5	26.7	2.4	35.7	0.1	53.0	53.9	0.9	Not Out of band emission(Leakage Power)
Hori	2809.418	AV	35.2	27.3	2.6	35.4	0.1	29.8	53.9	24.1	
Hori	4924.000	AV	39.4	31.0	4.2	34.9	0.1	39.8	53.9	14.1	
Hori	7386.000	AV	40.9	35.8	5.0	34.9	0.1	46.9	53.9	7.0	
Hori	9848.000	AV	37.7	38.6	5.8	35.4	0.1	46.8	53.9	7.1	
Vert	2483.500	PK	64.0	26.7	2.4	35.7	-	57.4	73.9	16.5	
Vert	2809.418	PK	46.9	27.3	2.6	35.4	-	41.4	73.9	32.5	
Vert	4924.000	PK	48.6	31.0	4.2	34.9	-	48.9	73.9	25.0	
Vert	7386.000	PK	48.9	35.8	5.0	34.9	-	54.8	73.9	19.1	
Vert	9848.000	PK	45.1	38.6	5.8	35.4	-	54.1	73.9	19.8	
Vert	2483.500	AV	53.3	26.7	2.4	35.7	0.1	46.8	53.9	7.1	Not Out of band emission(Leakage Power)
Vert	2809.418	AV	34.8	27.3	2.6	35.4	0.1	29.4	53.9	24.5	
Vert	4924.000	AV	39.2	31.0	4.2	34.9	0.1	39.6	53.9	14.3	
Vert	7386.000	AV	40.9	35.8	5.0	34.9	0.1	46.9	53.9	7.0	
Vert	9848.000	AV	37.5	38.6	5.8	35.4	0.1	46.6	53.9	7.3	

Result = Reading + Ant Factor + Loss (Cable+Attenuator+Filter-Distance factor(above 10GHz)) - Gain(Amplifier) + Duty Factor(AV)

*Other frequency noises omitted in this report were not seen or had enough margin (more than 20dB).

Distance factor: 10GHz-26.5GHz 20log(3.0m/1.0m)= 9.5dB

UL Japan, Inc.

Head Office EMC Lab.

4383-326 Asama-cho, Ise-shi, Mie-ken 516-0021 JAPAN

Telephone : +81 596 24 8999

Facsimile : +81 596 24 8124

Radiated Spurious Emission
(NR-241 (Right handle))

Test place Head Office EMC Lab. No.2 Semi Anechoic Chamber
Report No. 10012781H
Date 05/24/2013 05/24/2013
Temperature/ Humidity 20 deg. C / 51% RH 20 deg. C / 46% RH
Engineer Hiroshi Kukita Kazuya Yoshioka
(1-10GHz) (10-26.5GHz)
Mode 11n-20 Tx 2412MHz

Polarity	Frequency [MHz]	Detector	Reading [dBuV]	Ant.Fac. [dB/m]	Loss [dB]	Gain [dB]	Duty Factor [dB]	Result [dBuV/m]	Limit [dBuV/m]	Margin [dB]	Remark
Hori	2390.000	PK	66.3	26.8	2.4	35.7	-	59.8	73.9	14.1	
Hori	4824.000	PK	48.6	30.7	4.3	34.9	-	48.7	73.9	25.2	
Hori	7236.000	PK	42.6	35.6	4.9	34.9	-	48.2	73.9	25.7	
Hori	9648.000	PK	43.6	38.2	5.7	35.4	-	52.1	73.9	21.8	
Hori	2390.000	AV	56.3	26.8	2.4	35.7	0.1	49.9	53.9	4.0	Not Out of band emission(Leakage Power)
Hori	4824.000	AV	39.7	30.7	4.3	34.9	0.1	39.9	53.9	14.0	
Hori	7236.000	AV	41.0	35.6	4.9	34.9	0.1	46.7	53.9	7.2	
Hori	9648.000	AV	40.1	38.2	5.7	35.4	0.1	48.7	53.9	5.2	
Vert	2390.000	PK	57.1	26.8	2.4	35.7	-	50.6	73.9	23.3	
Vert	4824.000	PK	49.2	30.7	4.3	34.9	-	49.3	73.9	24.6	
Vert	7236.000	PK	43.2	35.6	4.9	34.9	-	48.8	73.9	25.1	
Vert	9648.000	PK	44.0	38.2	5.7	35.4	-	52.5	73.9	21.4	
Vert	2390.000	AV	47.0	26.8	2.4	35.7	0.1	40.6	53.9	13.3	Not Out of band emission(Leakage Power)
Vert	4824.000	AV	39.5	30.7	4.3	34.9	0.1	39.7	53.9	14.2	
Vert	7236.000	AV	34.9	35.6	4.9	34.9	0.1	40.6	53.9	13.3	
Vert	9648.000	AV	37.1	38.2	5.7	35.4	0.1	45.7	53.9	8.2	

Result = Reading + Ant Factor + Loss (Cable+Attenuator+Filter-Distance factor(above 10GHz)) - Gain(Amplifier) + Duty Factor(AV)

*Other frequency noises omitted in this report were not seen or had enough margin (more than 20dB).

Distance factor: 10GHz-26.5GHz 20log(3.0m/1.0m)= 9.5dB

20dBc Data Sheet

Polarity	Frequency [MHz]	Detector	Reading [dBuV]	Ant Factor [dB/m]	Loss [dB]	Gain [dB]	Result [dBuV/m]	Limit [dBuV/m]	Margin [dB]	Remark
Hori	2412.000	PK	104.9	26.8	2.4	35.7	98.4	-	-	Carrier
Hori	2400.000	PK	65.0	26.8	2.4	35.7	58.5	78.4	19.9	
Vert	2412.000	PK	96.3	26.8	2.4	35.7	89.8	-	-	Carrier
Vert	2400.000	PK	55.3	26.8	2.4	35.7	48.8	69.8	21.0	

Result = Reading + Ant Factor + Loss (Cable+Attenuator+Filter-Distance factor(above 10GHz)) - Gain(Amplifier)

UL Japan, Inc.

Head Office EMC Lab.

4383-326 Asama-cho, Ise-shi, Mie-ken 516-0021 JAPAN

Telephone : +81 596 24 8999

Facsimile : +81 596 24 8124

Radiated Spurious Emission
(NR-241 (Right handle))

Test place Head Office EMC Lab. No.2 Semi Anechoic Chamber
Report No. 10012781H
Date 05/24/2013 05/24/2013
Temperature/ Humidity 20 deg. C / 51% RH 20 deg. C / 46% RH
Engineer Hiroshi Kukita Kazuya Yoshioka
(1-10GHz) (30-1000MHz)
(10-26.5GHz)
Mode 11n-20 Tx 2437MHz

Polarity	Frequency [MHz]	Detector	Reading [dBuV]	Ant.Fac. [dB/m]	Loss [dB]	Gain [dB]	Duty Factor [dB]	Result [dBuV/m]	Limit [dBuV/m]	Margin [dB]	Remark
Hori	33.265	QP	27.9	16.7	6.8	28.6	-	22.8	40.0	17.2	
Hori	55.753	QP	23.1	9.1	7.0	28.6	-	10.6	40.0	29.4	
Hori	110.994	QP	27.7	11.7	7.6	28.3	-	18.7	43.5	24.8	
Hori	200.192	QP	21.8	16.6	8.1	27.8	-	18.7	43.5	24.8	
Hori	399.886	QP	23.1	17.4	9.3	28.4	-	21.4	46.0	24.6	
Hori	500.050	QP	23.0	18.0	9.8	28.8	-	22.0	46.0	24.0	
Hori	4874.000	PK	43.7	30.8	4.2	34.9	-	43.8	73.9	30.1	
Hori	7311.000	PK	43.4	35.7	4.9	34.9	-	49.1	73.9	24.8	
Hori	9748.000	PK	43.5	38.4	5.7	35.4	-	52.2	73.9	21.7	
Hori	4874.000	AV	35.0	30.8	4.2	34.9	0.1	35.2	53.9	18.7	
Hori	7311.000	AV	34.9	35.7	4.9	34.9	0.1	40.7	53.9	13.2	
Hori	9748.000	AV	34.9	38.4	5.7	35.4	0.1	43.7	53.9	10.2	
Vert	33.255	QP	28.8	16.7	6.8	28.6	-	23.7	40.0	16.3	
Vert	55.751	QP	26.5	9.1	7.0	28.6	-	14.0	40.0	26.0	
Vert	111.002	QP	28.3	11.7	7.6	28.3	-	19.3	43.5	24.2	
Vert	200.202	QP	21.8	16.6	8.1	27.8	-	18.7	43.5	24.8	
Vert	399.946	QP	23.1	17.4	9.3	28.4	-	21.4	46.0	24.6	
Vert	500.021	QP	23.0	18.0	9.8	28.8	-	22.0	46.0	24.0	
Vert	4874.000	PK	45.9	30.8	4.2	34.9	-	46.0	73.9	27.9	
Vert	7311.000	PK	43.0	35.7	4.9	34.9	-	48.7	73.9	25.2	
Vert	9748.000	PK	43.3	38.4	5.7	35.4	-	52.0	73.9	21.9	
Vert	4874.000	AV	37.1	30.8	4.2	34.9	0.1	37.3	53.9	16.6	
Vert	7311.000	AV	34.9	35.7	4.9	34.9	0.1	40.7	53.9	13.2	
Vert	9748.000	AV	34.2	38.4	5.7	35.4	0.1	43.0	53.9	10.9	

Result = Reading + Ant Factor + Loss (Cable+Attenuator+Filter-Distance factor(above 10GHz)) - Gain(Amplifier) + Duty Factor(AV)

*Other frequency noises omitted in this report were not seen or had enough margin (more than 20dB).

Distance factor: 10GHz-26.5GHz 20log(3.0m/1.0m)= 9.5dB

Radiated Spurious Emission
(NR-241 (Right handle))

Test place Head Office EMC Lab. No.2 Semi Anechoic Chamber
Report No. 10012781H
Date 05/24/2013 05/24/2013
Temperature/ Humidity 20 deg. C / 51% RH 20 deg. C / 46% RH
Engineer Hiroshi Kukita Kazuya Yoshioka
(1-10GHz) (10-26.5GHz)
Mode 11n-20 Tx 2462MHz

Polarity	Frequency [MHz]	Detector	Reading [dBuV]	Ant.Fac. [dB/m]	Loss [dB]	Gain [dB]	Duty Factor [dB]	Result [dBuV/m]	Limit [dBuV/m]	Margin [dB]	Remark
Hori	2383.800	PK	61.6	26.8	2.4	35.7	-	55.1	73.9	18.8	
Hori	2483.500	PK	73.0	26.7	2.4	35.7	-	66.4	73.9	7.5	
Hori	4924.000	PK	44.0	31.0	4.2	34.9	-	44.3	73.9	29.6	
Hori	7386.000	PK	43.4	35.8	5.0	34.9	-	49.3	73.9	24.6	
Hori	9848.000	PK	44.0	38.6	5.8	35.4	-	53.0	73.9	20.9	
Hori	2383.800	AV	53.4	26.8	2.4	35.7	0.1	47.0	53.9	6.9	
Hori	2483.500	AV	57.9	26.7	2.4	35.7	0.1	51.4	53.9	2.5	Not Out of band emission(Leakage Power)
Hori	4924.000	AV	34.7	31.0	4.2	34.9	0.1	35.1	53.9	18.8	
Hori	7386.000	AV	35.1	35.8	5.0	34.9	0.1	41.1	53.9	12.8	
Hori	9848.000	AV	35.4	38.6	5.8	35.4	0.1	44.5	53.9	9.4	
Vert	2415.500	PK	56.2	26.8	2.4	35.7	-	49.7	73.9	24.2	
Vert	2483.500	PK	60.2	26.7	2.4	35.7	-	53.6	73.9	20.3	
Vert	4924.000	PK	44.6	31.0	4.2	34.9	-	44.9	73.9	29.0	
Vert	7386.000	PK	43.0	35.8	5.0	34.9	-	48.9	73.9	25.0	
Vert	9848.000	PK	43.7	38.6	5.8	35.4	-	52.7	73.9	21.2	
Vert	2415.500	AV	46.2	26.8	2.4	35.7	0.1	39.8	53.9	14.1	
Vert	2483.500	AV	47.2	26.7	2.4	35.7	0.1	40.7	53.9	13.2	Not Out of band emission(Leakage Power)
Vert	4924.000	AV	35.5	31.0	4.2	34.9	0.1	35.9	53.9	18.0	
Vert	7386.000	AV	35.3	35.8	5.0	34.9	0.1	41.3	53.9	12.6	
Vert	9848.000	AV	35.5	38.6	5.8	35.4	0.1	44.6	53.9	9.3	

Result = Reading + Ant Factor + Loss (Cable+Attenuator+Filter-Distance factor(above 10GHz)) - Gain(Amplifier) + Duty Factor(AV)

*Other frequency noises omitted in this report were not seen or had enough margin (more than 20dB).

Distance factor: 10GHz-26.5GHz 20log(3.0m/1.0m)= 9.5dB

UL Japan, Inc.

Head Office EMC Lab.

4383-326 Asama-cho, Ise-shi, Mie-ken 516-0021 JAPAN

Telephone : +81 596 24 8999

Facsimile : +81 596 24 8124

Radiated Spurious Emission
(NR-243UH (Internal Amplifier))

Test place : Head Office EMC Lab. No.4 Semi Anechoic Chamber
Report No. : 100012781H
Date : 05/31/2013
Temperature/ Humidity : 22 deg. C / 69% RH 22 deg. C / 59% RH
Engineer : Shinya Watanabe Hiroshi Kukita
(1-10GHz) (10-26.5GHz)
Mode : 11n-20 Tx 2412MHz

Polarity	Frequency [MHz]	Detector	Reading [dBuV]	Ant.Fac. [dB/m]	Loss [dB]	Gain [dB]	Duty Factor [dB]	Result [dBuV/m]	Limit [dBuV/m]	Margin [dB]	Remark
Hori	2390.000	PK	62.5	27.5	2.6	32.4	-	60.2	73.9	13.7	
Hori	4824.000	PK	42.0	31.4	5.1	31.6	-	46.9	73.9	27.0	
Hori	7236.000	PK	42.2	35.8	6.0	32.7	-	51.3	73.9	22.6	
Hori	9648.000	PK	43.4	38.3	6.9	33.3	-	55.3	73.9	18.6	
Hori	2390.000	AV	51.4	27.5	2.6	32.4	0.1	49.2	53.9	4.7	Not Out of band emission(Leakage Power)
Hori	4824.000	AV	32.3	31.4	5.1	31.6	0.1	37.3	53.9	16.6	
Hori	7236.000	AV	33.8	35.8	6.0	32.7	0.1	43.0	53.9	10.9	
Hori	9648.000	AV	34.2	38.3	6.9	33.3	0.1	46.2	53.9	7.7	
Vert	2390.000	PK	62.3	27.5	2.6	32.4	-	60.0	73.9	13.9	
Vert	4824.000	PK	42.8	31.4	5.1	31.6	-	47.7	73.9	26.2	
Vert	7236.000	PK	42.2	35.8	6.0	32.7	-	51.3	73.9	22.6	
Vert	9648.000	PK	43.3	38.3	6.9	33.3	-	55.2	73.9	18.7	
Vert	2390.000	AV	49.5	27.5	2.6	32.4	0.1	47.3	53.9	6.6	Not Out of band emission(Leakage Power)
Vert	4824.000	AV	33.4	31.4	5.1	31.6	0.1	38.4	53.9	15.5	
Vert	7236.000	AV	33.8	35.8	6.0	32.7	0.1	43.0	53.9	10.9	
Vert	9648.000	AV	34.2	38.3	6.9	33.3	0.1	46.2	53.9	7.7	

Result = Reading + Ant Factor + Loss (Cable+Attenuator+Filter-Distance factor(above 10GHz)) - Gain(Amplifier) + Duty Factor(AV)

*Other frequency noises omitted in this report were not seen or had enough margin (more than 20dB).

Distance factor: 10GHz-26.5GHz 20log(3.0m/1.0m)= 9.5dB

20dBc Data Sheet

Polarity	Frequency [MHz]	Detector	Reading [dBuV]	Ant Factor [dB/m]	Loss [dB]	Gain [dB]	Result [dBuV/m]	Limit [dBuV/m]	Margin [dB]	Remark
Hori	2412.000	PK	98.8	27.5	2.6	32.4	96.5	-	-	Carrier
Hori	2400.000	PK	59.6	27.5	2.6	32.4	57.3	76.5	19.2	
Vert	2412.000	PK	97.0	27.5	2.6	32.4	94.7	-	-	Carrier
Vert	2400.000	PK	56.7	27.5	2.6	32.4	54.4	74.7	20.3	

Result = Reading + Ant Factor + Loss (Cable+Attenuator+Filter-Distance factor(above 10GHz)) - Gain(Amplifier)

UL Japan, Inc.

Head Office EMC Lab.

4383-326 Asama-cho, Ise-shi, Mie-ken 516-0021 JAPAN

Telephone : +81 596 24 8999

Facsimile : +81 596 24 8124

Radiated Spurious Emission
(NR-241UH (Internal Amplifier))

Test place : Head Office EMC Lab. No.4 Semi Anechoic Chamber
Report No. : 10012781H
Date : 06/02/2013
Temperature/ Humidity : 23 deg. C / 61% RH
Engineer : Hironobu Ohnishi
(1-26.5GHz)
Mode : 11b Tx 2412MHz

Polarity	Frequency [MHz]	Detector	Reading [dBuV]	Ant.Fac. [dB/m]	Loss [dB]	Gain [dB]	Result [dBuV/m]	Limit [dBuV/m]	Margin [dB]	Remark
Hori	2390.000	PK	72.1	27.5	2.6	32.4	69.8	73.9	4.1	
Hori	2822.315	PK	50.6	28.2	2.8	32.2	49.4	73.9	24.5	
Hori	4824.000	PK	48.4	31.4	4.4	31.6	52.6	73.9	21.3	
Hori	7236.000	PK	43.5	35.8	5.3	32.7	51.9	73.9	22.0	
Hori	9648.000	PK	43.6	38.3	6.1	33.3	54.7	73.9	19.2	
Hori	2390.000	AV	47.3	27.5	2.6	32.4	45.0	53.9	8.9	
Hori	2822.315	AV	47.9	28.2	2.8	32.2	46.7	53.9	7.2	
Hori	4824.000	AV	43.3	31.4	4.4	31.6	47.5	53.9	6.4	
Hori	7236.000	AV	34.0	35.8	5.3	32.7	42.4	53.9	11.5	
Hori	9648.000	AV	34.7	38.3	6.1	33.3	45.8	53.9	8.1	
Vert	2390.000	PK	67.6	27.5	2.6	32.4	65.3	73.9	8.6	
Vert	2822.315	PK	49.4	28.2	2.8	32.2	48.2	73.9	25.7	
Vert	4824.000	PK	50.1	31.4	4.4	31.6	54.3	73.9	19.6	
Vert	7236.000	PK	42.2	35.8	5.3	32.7	50.6	73.9	23.3	
Vert	9648.000	PK	42.7	38.3	6.1	33.3	53.8	73.9	20.1	
Vert	2390.000	AV	43.0	27.5	2.6	32.4	40.7	53.9	13.2	
Vert	2822.315	AV	45.5	28.2	2.8	32.2	44.3	53.9	9.6	
Vert	4824.000	AV	45.8	31.4	4.4	31.6	50.0	53.9	3.9	
Vert	7236.000	AV	33.8	35.8	5.3	32.7	42.2	53.9	11.7	
Vert	9648.000	AV	35.1	38.3	6.1	33.3	46.2	53.9	7.7	

Result = Reading + Ant Factor + Loss (Cable+Attenuator+Filter-Distance factor(above 10GHz)) - Gain(Amplifier)

*Other frequency noises omitted in this report were not seen or had enough margin (more than 20dB).

Distance factor: 10GHz-26.5GHz 20log(3.0m/1.0m)= 9.5dB

20dBc Data Sheet

Polarity	Frequency [MHz]	Detector	Reading [dBuV]	Ant Factor [dB/m]	Loss [dB]	Gain [dB]	Result [dBuV/m]	Limit [dBuV/m]	Margin [dB]	Remark
Hori	2412.000	PK	105.6	27.5	2.6	32.4	103.3	-	-	Carrier
Hori	2399.500	PK	63.0	27.5	2.6	32.4	60.7	83.3	22.6	
Hori	2400.000	PK	61.8	27.5	2.6	32.4	59.5	83.3	23.8	
Vert	2412.000	PK	100.0	27.5	2.6	32.4	97.7	-	-	Carrier
Vert	2399.500	PK	58.0	27.5	2.6	32.4	55.7	77.7	22.0	
Vert	2400.000	PK	56.9	27.5	2.6	32.4	54.6	77.7	23.1	

Result = Reading + Ant Factor + Loss (Cable+Attenuator+Filter-Distance factor(above 10GHz)) - Gain(Amplifier)

UL Japan, Inc.

Head Office EMC Lab.

4383-326 Asama-cho, Ise-shi, Mie-ken 516-0021 JAPAN

Telephone : +81 596 24 8999

Facsimile : +81 596 24 8124

Radiated Spurious Emission
(NR-241UH (Internal Amplifier))

Test place : Head Office EMC Lab. No.4 Semi Anechoic Chamber
Report No. : 10012781H
Date : 06/02/2013
Temperature/ Humidity : 23 deg. C / 61% RH
Engineer : Hironobu Ohnishi
(1-26.5GHz)
Mode : 11b Tx 2437MHz

Polarity	Frequency [MHz]	Detector	Reading [dBuV]	Ant.Fac. [dB/m]	Loss [dB]	Gain [dB]	Result [dBuV/m]	Limit [dBuV/m]	Margin [dB]	Remark
Hori	2822.315	PK	51.1	28.2	2.8	32.2	49.9	73.9	24.0	
Hori	4874.000	PK	47.6	31.5	4.4	31.6	51.9	73.9	22.0	
Hori	7311.000	PK	42.3	35.8	5.3	32.7	50.7	73.9	23.2	
Hori	9748.000	PK	43.4	38.4	6.1	33.4	54.5	73.9	19.4	
Hori	2822.315	AV	48.6	28.2	2.8	32.2	47.4	53.9	6.5	
Hori	4874.000	AV	43.4	31.5	4.4	31.6	47.7	53.9	6.2	
Hori	7311.000	AV	33.9	35.8	5.3	32.7	42.3	53.9	11.6	
Hori	9748.000	AV	34.9	38.4	6.1	33.4	46.0	53.9	7.9	
Vert	2822.315	PK	49.6	28.2	2.8	32.2	48.4	73.9	25.5	
Vert	4874.000	PK	48.8	31.5	4.4	31.6	53.1	73.9	20.8	
Vert	7311.000	PK	43.0	35.8	5.3	32.7	51.4	73.9	22.5	
Vert	9748.000	PK	43.1	38.4	6.1	33.4	54.2	73.9	19.7	
Vert	2822.315	AV	46.3	28.2	2.8	32.2	45.1	53.9	8.8	
Vert	4874.000	AV	44.7	31.5	4.4	31.6	49.0	53.9	4.9	
Vert	7311.000	AV	33.8	35.8	5.3	32.7	42.2	53.9	11.7	
Vert	9748.000	AV	34.3	38.4	6.1	33.4	45.4	53.9	8.5	

Result = Reading + Ant Factor + Loss (Cable+Attenuator+Filter-Distance factor(above 10GHz)) - Gain(Amplifier)

*Other frequency noises omitted in this report were not seen or had enough margin (more than 20dB).

Distance factor: 10GHz-26.5GHz 20log(3.0m/1.0m)= 9.5dB

UL Japan, Inc.

Head Office EMC Lab.

4383-326 Asama-cho, Ise-shi, Mie-ken 516-0021 JAPAN

Telephone : +81 596 24 8999

Facsimile : +81 596 24 8124

Radiated Spurious Emission
(NR-241UH (Internal Amplifier))

Test place : Head Office EMC Lab. No.4 Semi Anechoic Chamber
Report No. : 10012781H
Date : 06/02/2013
Temperature/ Humidity : 23 deg. C / 61% RH
Engineer : Hironobu Ohnishi
(1-26.5GHz)
Mode : 11b Tx 2462MHz

Polarity	Frequency [MHz]	Detector	Reading [dBuV]	Ant.Fac. [dB/m]	Loss [dB]	Gain [dB]	Result [dBuV/m]	Limit [dBuV/m]	Margin [dB]	Remark
Hori	2483.500	PK	73.2	27.5	2.7	32.4	71.0	73.9	2.9	
Hori	2822.315	PK	51.2	28.2	2.8	32.2	50.0	73.9	23.9	
Hori	4924.000	PK	49.6	31.7	4.5	31.6	54.2	73.9	19.7	
Hori	7386.000	PK	42.4	35.9	5.3	32.8	50.8	73.9	23.1	
Hori	9848.000	PK	43.3	38.5	6.2	33.4	54.6	73.9	19.3	
Hori	2483.500	AV	46.8	27.5	2.7	32.4	44.6	53.9	9.3	
Hori	2822.315	AV	48.4	28.2	2.8	32.2	47.2	53.9	6.7	
Hori	4924.000	AV	45.4	31.7	4.5	31.6	50.0	53.9	3.9	
Hori	7386.000	AV	33.7	35.9	5.3	32.8	42.1	53.9	11.8	
Hori	9848.000	AV	34.5	38.5	6.2	33.4	45.8	53.9	8.1	
Vert	2483.500	PK	65.9	27.5	2.7	32.4	63.7	73.9	10.2	
Vert	2822.315	PK	49.5	28.2	2.8	32.2	48.3	73.9	25.6	
Vert	4924.000	PK	51.2	31.7	4.5	31.6	55.8	73.9	18.1	
Vert	7386.000	PK	42.2	35.9	5.3	32.8	50.6	73.9	23.3	
Vert	9848.000	PK	43.4	38.5	6.2	33.4	54.7	73.9	19.2	
Vert	2483.500	AV	40.3	27.5	2.7	32.4	38.1	53.9	15.8	
Vert	2822.315	AV	46.1	28.2	2.8	32.2	44.9	53.9	9.0	
Vert	4924.000	AV	47.0	31.7	4.5	31.6	51.6	53.9	2.3	
Vert	7386.000	AV	33.6	35.9	5.3	32.8	42.0	53.9	11.9	
Vert	9848.000	AV	34.1	38.5	6.2	33.4	45.4	53.9	8.5	

Result = Reading + Ant Factor + Loss (Cable+Attenuator+Filter-Distance factor(above 10GHz)) - Gain(Amplifier)

*Other frequency noises omitted in this report were not seen or had enough margin (more than 20dB).

Distance factor: 10GHz-26.5GHz 20log(3.0m/1.0m)= 9.5dB

UL Japan, Inc.

Head Office EMC Lab.

4383-326 Asama-cho, Ise-shi, Mie-ken 516-0021 JAPAN

Telephone : +81 596 24 8999

Facsimile : +81 596 24 8124

Radiated Spurious Emission
(NR-241UH (Internal Amplifier))

Test place : Head Office EMC Lab. No.4 Semi Anechoic Chamber
Report No. : 10012781H
Date : 06/01/2013
Temperature/ Humidity : 24 deg. C / 61% RH
Engineer : Hironobu Ohnishi
(30-1000GHz)
Mode : 11n-20 Tx 2437MHz

Polarity	Frequency [MHz]	Detector	Reading [dBuV]	Ant.Fac. [dB/m]	Loss [dB]	Gain [dB]	Duty Factor [dB]	Result [dBuV/m]	Limit [dBuV/m]	Margin [dB]	Remark
Hori	42.000	QP	22.9	14.0	7.3	32.2	-	12.0	40.0	28.0	
Hori	96.291	QP	25.7	9.7	8.0	32.1	-	11.3	43.5	32.2	
Hori	111.000	QP	30.9	12.2	8.2	32.1	-	19.2	43.5	24.3	
Hori	150.765	QP	27.1	15.1	8.6	32.1	-	18.7	43.5	24.8	
Hori	406.998	QP	25.9	17.9	10.5	32.0	-	22.3	46.0	23.7	
Hori	610.000	QP	22.0	20.2	11.6	32.1	-	21.7	46.0	24.3	
Vert	42.000	QP	23.1	14.0	7.3	32.2	-	12.2	40.0	27.8	
Vert	96.291	QP	29.6	9.7	8.0	32.1	-	15.2	43.5	28.3	
Vert	111.000	QP	30.2	12.2	8.2	32.1	-	18.5	43.5	25.0	
Vert	150.765	QP	32.8	15.1	8.6	32.1	-	24.4	43.5	19.1	
Vert	406.998	QP	27.6	17.9	10.5	32.0	-	24.0	46.0	22.0	
Vert	610.000	QP	22.0	20.2	11.6	32.1	-	21.7	46.0	24.3	

Result = Reading + Ant Factor + Loss (Cable+Attenuator+Filter-Distance factor(above 10GHz)) - Gain(Amplifier) + Duty Factor(AV)

*Other frequency noises omitted in this report were not seen or had enough margin (more than 20dB).

Distance factor: 10GHz-26.5GHz 20log(3.0m/1.0m)= 9.5dB

UL Japan, Inc.

Head Office EMC Lab.

4383-326 Asama-cho, Ise-shi, Mie-ken 516-0021 JAPAN

Telephone : +81 596 24 8999

Facsimile : +81 596 24 8124

Radiated Spurious Emission
(NR-241UH (External Amplifier))

Test place Head Office EMC Lab. No.4 Semi Anechoic Chamber
Report No. 10012781H
Date 06/26/2013 06/27/2013
Temperature/ Humidity 23 deg. C / 69% RH 23 deg. C / 68% RH
Engineer Shinya Watanabe Hiroshi Kukita
(10-26.5GHz) (1-10GHz)
Mode 11n-20 Tx 2412MHz

Polarity	Frequency [MHz]	Detector	Reading [dBuV]	Ant.Fac. [dB/m]	Loss [dB]	Gain [dB]	Duty Factor [dB]	Result [dBuV/m]	Limit [dBuV/m]	Margin [dB]	Remark
Hori	2390.000	PK	65.4	27.5	2.6	32.4	-	63.1	73.9	10.8	
Hori	4824.000	PK	40.7	31.4	4.4	31.6	-	44.9	73.9	29.0	
Hori	7236.000	PK	43.5	35.8	5.3	32.7	-	51.9	73.9	22.0	
Hori	9648.000	PK	43.0	38.3	6.1	33.3	-	54.1	73.9	19.8	
Hori	2390.000	AV	52.2	27.5	2.6	32.4	0.1	50.0	53.9	3.9	Not Out of band emission(Leakage Power)
Hori	4824.000	AV	30.8	31.4	4.4	31.6	0.1	35.1	53.9	18.8	
Hori	7236.000	AV	32.2	35.8	5.3	32.7	0.1	40.7	53.9	13.2	
Hori	9648.000	AV	33.7	38.3	6.1	33.3	0.1	44.9	53.9	9.0	
Vert	2390.000	PK	62.4	27.5	2.6	32.4	-	60.1	73.9	13.8	
Vert	4824.000	PK	41.0	31.4	4.4	31.6	-	45.2	73.9	28.7	
Vert	7236.000	PK	42.9	35.8	5.3	32.7	-	51.3	73.9	22.6	
Vert	9648.000	PK	43.6	38.3	6.1	33.3	-	54.7	73.9	19.2	
Vert	2390.000	AV	48.9	27.5	2.6	32.4	0.1	46.7	53.9	7.2	Not Out of band emission(Leakage Power)
Vert	4824.000	AV	32.5	31.4	4.4	31.6	0.1	36.8	53.9	17.1	
Vert	7236.000	AV	33.9	35.8	5.3	32.7	0.1	42.4	53.9	11.5	
Vert	9648.000	AV	35.2	38.3	6.1	33.3	0.1	46.4	53.9	7.5	

Result = Reading + Ant Factor + Loss (Cable+Attenuator+Filter-Distance factor(above 10GHz)) - Gain(Amplifier) + Duty Factor(AV)

*Other frequency noises omitted in this report were not seen or had enough margin (more than 20dB).

Distance factor: 10GHz-26.5GHz 20log(3.0m/1.0m)= 9.5dB

20dBc Data Sheet

Polarity	Frequency [MHz]	Detector	Reading [dBuV]	Ant Factor [dB/m]	Loss [dB]	Gain [dB]	Result [dBuV/m]	Limit [dBuV/m]	Margin [dB]	Remark
Hori	2412.000	PK	97.2	27.5	2.6	32.4	94.9	-	-	Carrier
Hori	2400.000	PK	58.8	27.5	2.6	32.4	56.5	74.9	18.4	
Vert	2412.000	PK	96.6	27.5	2.6	32.4	94.3	-	-	Carrier
Vert	2400.000	PK	57.2	27.5	2.6	32.4	54.9	74.3	19.4	

Result = Reading + Ant Factor + Loss (Cable+Attenuator+Filter-Distance factor(above 10GHz)) - Gain(Amplifier)

UL Japan, Inc.

Head Office EMC Lab.

4383-326 Asama-cho, Ise-shi, Mie-ken 516-0021 JAPAN

Telephone : +81 596 24 8999

Facsimile : +81 596 24 8124

Radiated Spurious Emission
(NR-241UH (External Amplifier))

Test place Head Office EMC Lab. No.4 Semi Anechoic Chamber
Report No. 10012781H
Date 06/26/2013 06/27/2013 06/27/2013
Temperature/ Humidity 23 deg. C / 69% RH 23 deg. C / 68% RH 23 deg. C / 63% RH
Engineer Shinya Watanabe Hiroshi Kukita Katsunori Okai
(10-26.5GHz) (1-10GHz) (30-1000MHz)
Mode 11n-20 Tx 2437MHz

Polarity	Frequency [MHz]	Detector	Reading [dBuV]	Ant.Fac. [dB/m]	Loss [dB]	Gain [dB]	Duty Factor [dB]	Result [dBuV/m]	Limit [dBuV/m]	Margin [dB]	Remark
Hori	96.000	QP	27.2	9.7	8.1	32.0	-	13.0	43.5	30.5	
Hori	111.001	QP	32.4	12.2	8.2	31.9	-	20.9	43.5	22.6	
Hori	135.195	QP	25.4	14.4	8.5	31.9	-	16.4	43.5	27.1	
Hori	158.076	QP	24.3	15.3	8.7	31.9	-	16.4	43.5	27.1	
Hori	406.997	QP	26.0	17.9	10.6	32.0	-	22.5	46.0	23.5	
Hori	591.996	QP	22.8	19.9	11.7	32.1	-	22.3	46.0	23.7	
Hori	4874.000	PK	41.4	31.5	4.4	31.6	-	45.7	73.9	28.2	
Hori	7311.000	PK	42.4	35.8	5.3	32.7	-	50.8	73.9	23.1	
Hori	9748.000	PK	43.4	38.4	6.1	33.4	-	54.5	73.9	19.4	
Hori	4874.000	AV	32.4	31.5	4.4	31.6	0.1	36.8	53.9	17.1	
Hori	7311.000	AV	33.7	35.8	5.3	32.7	0.1	42.2	53.9	11.7	
Hori	9748.000	AV	35.1	38.4	6.1	33.4	0.1	46.3	53.9	7.6	
Vert	96.000	QP	31.2	9.7	8.1	32.0	-	17.0	43.5	26.5	
Vert	111.002	QP	34.9	12.2	8.2	31.9	-	23.4	43.5	20.1	
Vert	135.196	QP	28.2	14.4	8.5	31.9	-	19.2	43.5	24.3	
Vert	158.076	QP	29.1	15.3	8.7	31.9	-	21.2	43.5	22.3	
Vert	406.998	QP	28.2	17.9	10.6	32.0	-	24.7	46.0	21.3	
Vert	591.995	QP	26.3	19.9	11.7	32.1	-	25.8	46.0	20.2	
Vert	4874.000	PK	40.9	31.5	4.4	31.6	-	45.2	73.9	28.7	
Vert	7311.000	PK	42.0	35.8	5.3	32.7	-	50.4	73.9	23.5	
Vert	9748.000	PK	43.0	38.4	6.1	33.4	-	54.1	73.9	19.8	
Vert	4874.000	AV	32.2	31.5	4.4	31.6	0.1	36.6	53.9	17.3	
Vert	7311.000	AV	33.6	35.8	5.3	32.7	0.1	42.1	53.9	11.8	
Vert	9748.000	AV	35.3	38.4	6.1	33.4	0.1	46.5	53.9	7.4	

Result = Reading + Ant Factor + Loss (Cable+Attenuator+Filter-Distance factor(above 10GHz)) - Gain(Amplifier) + Duty Factor(AV)

*Other frequency noises omitted in this report were not seen or had enough margin (more than 20dB).

Distance factor: 10GHz-26.5GHz 20log(3.0m/1.0m)= 9.5dB

UL Japan, Inc.

Head Office EMC Lab.

4383-326 Asama-cho, Ise-shi, Mie-ken 516-0021 JAPAN

Telephone : +81 596 24 8999

Facsimile : +81 596 24 8124

Radiated Spurious Emission
(NR-243UH (External Amplifier))

Test place Head Office EMC Lab. No.4 Semi Anechoic Chamber
Report No. 10012781H
Date 06/26/2013 06/27/2013 06/27/2013
Temperature/ Humidity 23 deg. C / 69% RH 23 deg. C / 68% RH 23 deg. C / 63% RH
Engineer Shinya Watanabe Hiroshi Kukita Katsunori Okai
(10-26.5GHz) (1-10GHz) (30-1000MHz)
Mode 11n-20 Tx 2437MHz

Polarity	Frequency [MHz]	Detector	Reading [dBuV]	Ant.Fac. [dB/m]	Loss [dB]	Gain [dB]	Duty Factor [dB]	Result [dBuV/m]	Limit [dBuV/m]	Margin [dB]	Remark
Hori	96.342	QP	26.0	9.7	8.1	32.0	-	11.8	43.5	31.7	
Hori	111.001	QP	32.2	12.2	8.2	31.9	-	20.7	43.5	22.8	
Hori	135.197	QP	23.4	14.4	8.5	31.9	-	14.4	43.5	29.1	
Hori	349.995	QP	25.2	17.1	10.2	32.0	-	20.5	46.0	25.5	
Hori	406.997	QP	26.1	17.9	10.6	32.0	-	22.6	46.0	23.4	
Hori	480.997	QP	23.1	18.8	11.1	32.0	-	21.0	46.0	25.0	
Hori	4874.000	PK	40.8	31.5	4.4	31.6	-	45.1	73.9	28.8	
Hori	7311.000	PK	41.7	35.8	5.3	32.7	-	50.1	73.9	23.8	
Hori	9748.000	PK	42.9	38.4	6.1	33.4	-	54.0	73.9	19.9	
Hori	4874.000	AV	32.6	31.5	4.4	31.6	0.1	37.0	53.9	16.9	
Hori	7311.000	AV	33.7	35.8	5.3	32.7	0.1	42.2	53.9	11.7	
Hori	9748.000	AV	35.0	38.4	6.1	33.4	0.1	46.2	53.9	7.7	
Vert	96.341	QP	29.1	9.7	8.1	32.0	-	14.9	43.5	28.6	
Vert	110.999	QP	31.8	12.2	8.2	31.9	-	20.3	43.5	23.2	
Vert	135.195	QP	27.5	14.4	8.5	31.9	-	18.5	43.5	25.0	
Vert	349.999	QP	29.5	17.1	10.2	32.0	-	24.8	46.0	21.2	
Vert	406.996	QP	27.7	17.9	10.6	32.0	-	24.2	46.0	21.8	
Vert	481.001	QP	26.4	18.8	11.1	32.0	-	24.3	46.0	21.7	
Vert	4874.000	PK	40.8	31.5	4.4	31.6	-	45.1	73.9	28.8	
Vert	7311.000	PK	42.5	35.8	5.3	32.7	-	50.9	73.9	23.0	
Vert	9748.000	PK	43.9	38.4	6.1	33.4	-	55.0	73.9	18.9	
Vert	4874.000	AV	32.7	31.5	4.4	31.6	0.1	37.1	53.9	16.8	
Vert	7311.000	AV	33.7	35.8	5.3	32.7	0.1	42.2	53.9	11.7	
Vert	9748.000	AV	35.2	38.4	6.1	33.4	0.1	46.4	53.9	7.5	

Result = Reading + Ant Factor + Loss (Cable+Attenuator+Filter-Distance factor(above 10GHz)) - Gain(Amplifier) + Duty Factor (AV)

*Other frequency noises omitted in this report were not seen or had enough margin (more than 20dB).

Distance factor: 10GHz-26.5GHz 20log(3.0m/1.0m)= 9.5dB

UL Japan, Inc.

Head Office EMC Lab.

4383-326 Asama-cho, Ise-shi, Mie-ken 516-0021 JAPAN

Telephone : +81 596 24 8999

Facsimile : +81 596 24 8124

Burst rate confirmation

11b 2Mbps

Tx on / (Tx on + Tx off) = 0.997
Tx on / (Tx on + Tx off) * 100 = 99.7 %
Duty factor = 10 * log (9.542 / 9.517) = 0.01 dB

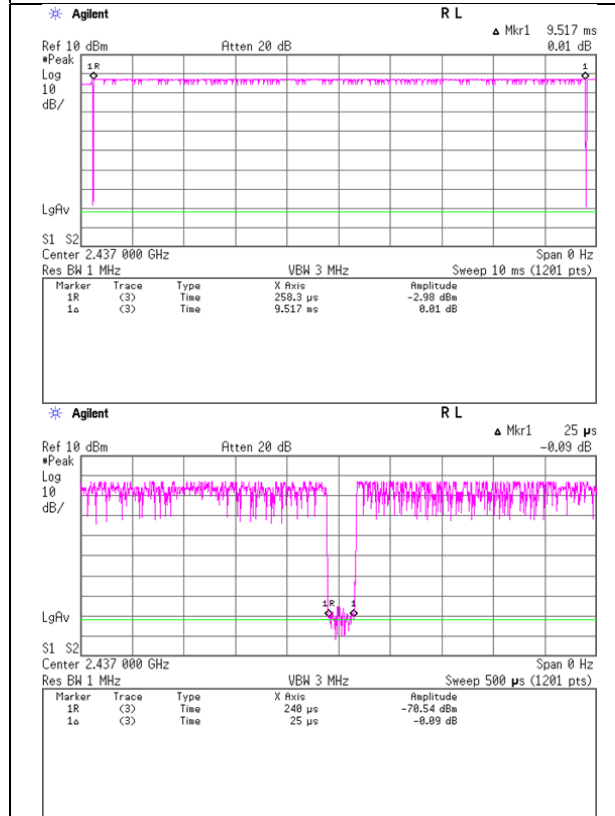

UL Japan, Inc.

Head Office EMC Lab.

4383-326 Asama-cho, Ise-shi, Mie-ken 516-0021 JAPAN

Telephone : +81 596 24 8999

Facsimile : +81 596 24 8124

Burst rate confirmation

11g 12Mbps

Tx on / (Tx on + Tx off) = 0.981
Tx on / (Tx on + Tx off) * 100 = 98.1 %
Duty factor = 10 * log (1.618 / 1.587) = 0.08 dB

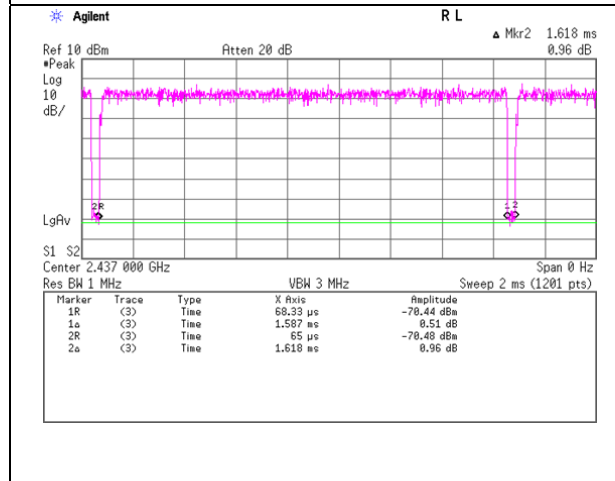

11n-20 MCS2

Tx on / (Tx on + Tx off) = 0.975
Tx on / (Tx on + Tx off) * 100 = 97.5 %
Duty factor = 10 * log (1.03 / 1.004) = 0.11 dB

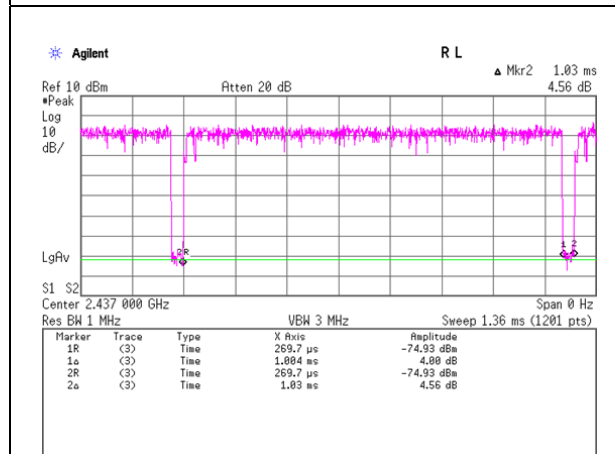

UL Japan, Inc.

Head Office EMC Lab.

4383-326 Asama-cho, Ise-shi, Mie-ken 516-0021 JAPAN

Telephone : +81 596 24 8999

Facsimile : +81 596 24 8124

Conducted Spurious Emission

11n-20 Tx 2437MHz

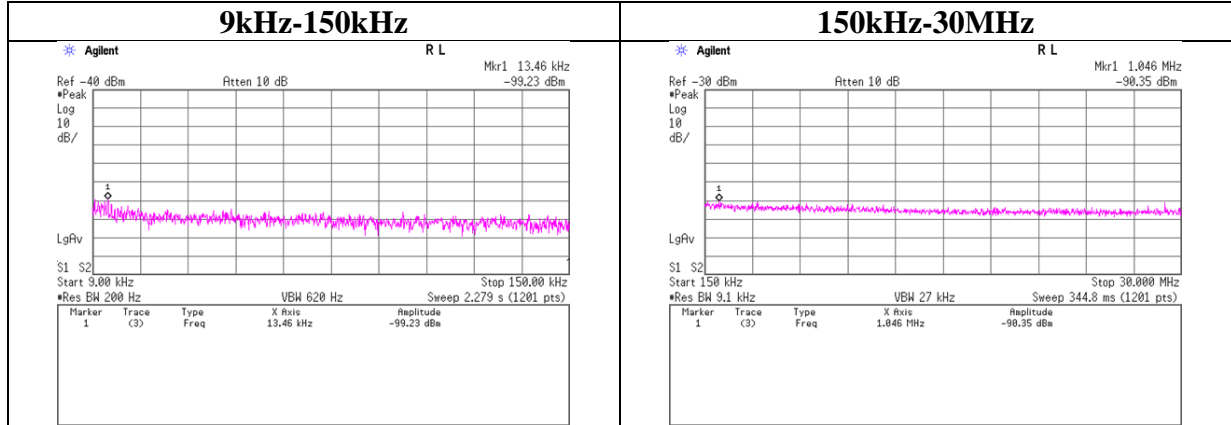

Frequency [kHz]	Reading [dBm]	Cable Loss [dB]	Attenuator [dB]	Antenna Gain [dBi]	EIRP [dBm]	Distance [m]	Ground bounce [dB]	E (field strength) [dBuV/m]	Limit [dBuV/m]
13.46	-99.2	0.01	9.9	-1.9	-91.3	300.0	6.0	-30.0	45.0
1046	-90.4	0.02	9.8	-1.9	-82.4	30.0	6.0	-1.1	27.2

E=EIRP-20log(D)+Ground bounce +104.8[dBuV/m]
EIRP=Reading+Cable Loss+Attenuator+Antenna Gain

Power Density

Test place Head Office EMC Lab. No.6 Measurement Room
Report No. 10012781H
Date 05/24/2013
Temperature/ Humidity 23 deg. C / 58% RH
Engineer Satofumi Matsuyama
Mode 11b Tx, 11g Tx

11b

Freq. [MHz]	Reading [dBm]	Cable Loss [dB]	Atten. [dB]	Result [dBm]	Limit [dBm]	Margin [dB]
2412.00	-6.02	1.87	10.01	5.86	8.00	2.14
2437.00	-5.96	1.87	10.01	5.92	8.00	2.08
2462.00	-5.26	1.88	10.01	6.63	8.00	1.37

11g

Freq. [MHz]	Reading [dBm]	Cable Loss [dB]	Atten. [dB]	Result [dBm]	Limit [dBm]	Margin [dB]
2412.00	-24.93	1.87	10.01	-13.05	8.00	21.05
2437.00	-24.35	1.87	10.01	-12.47	8.00	20.47
2462.00	-25.03	1.88	10.01	-13.14	8.00	21.14

Sample Calculation:

Result = Reading + Cable Loss (including the cable(s) customer supplied) + Attenuator

UL Japan, Inc.

Head Office EMC Lab.

4383-326 Asama-cho, Ise-shi, Mie-ken 516-0021 JAPAN

Telephone : +81 596 24 8999

Facsimile : +81 596 24 8124

Power Density

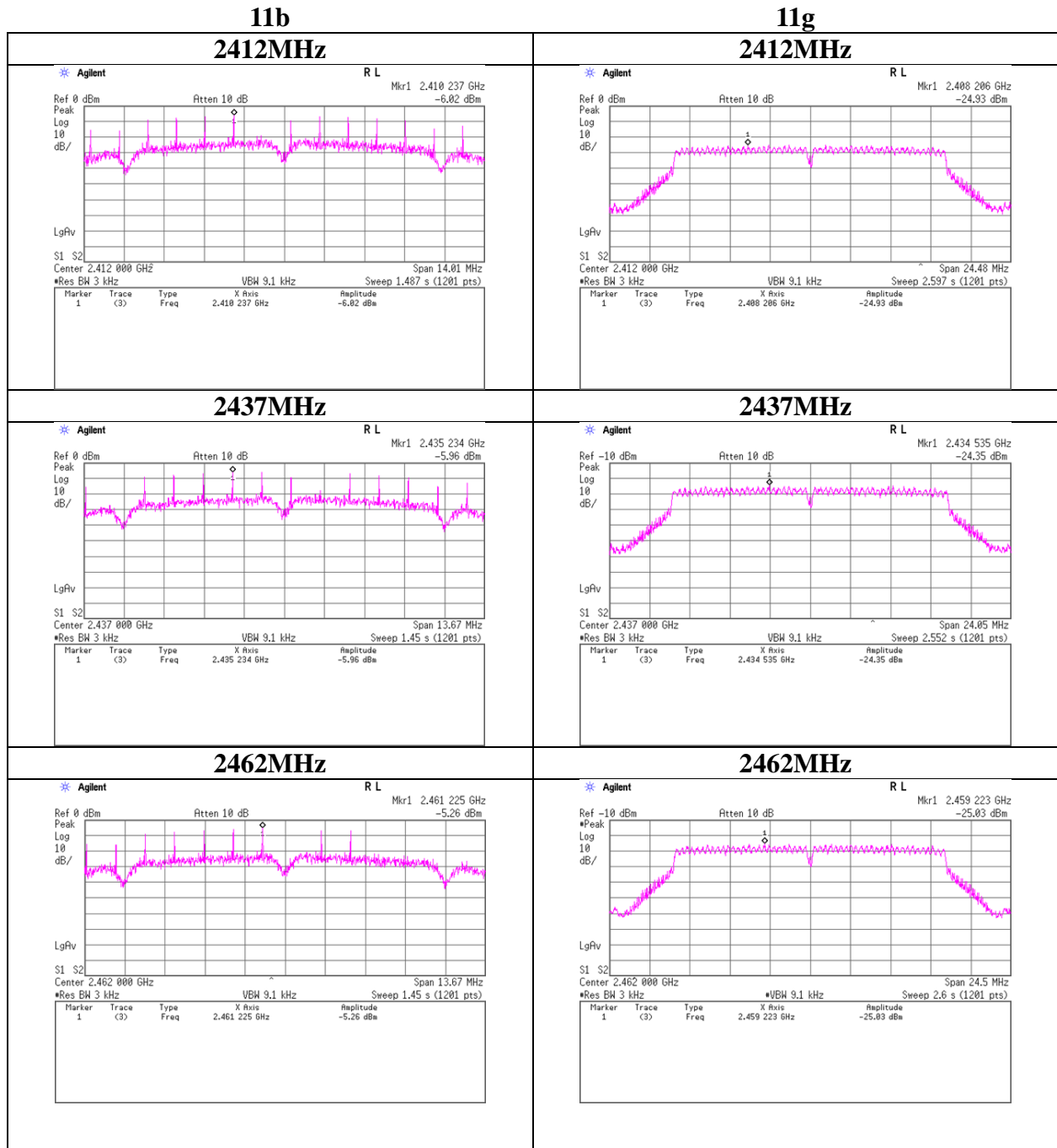

Power Density

11n-20 Antenna 2412MHz

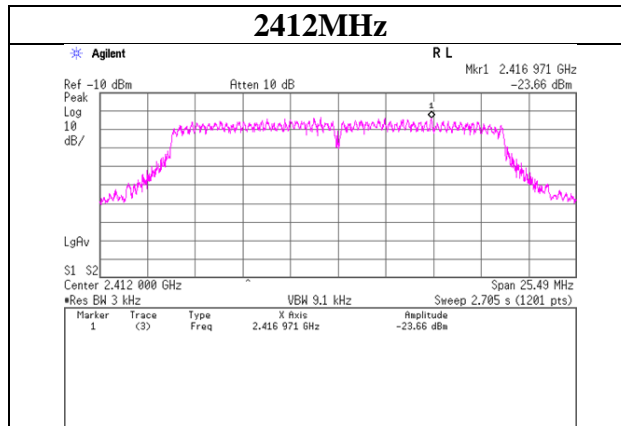

2437MHz

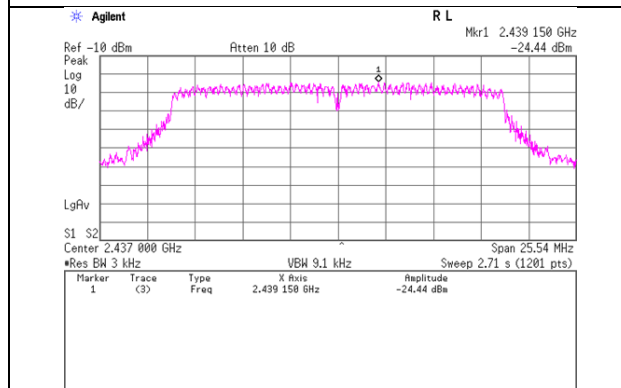

2462MHz

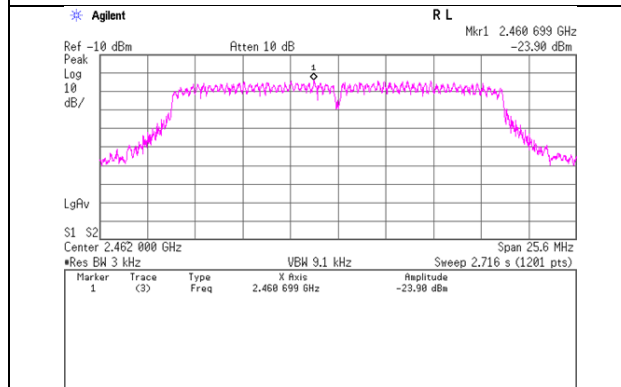

99%Occupied Bandwidth

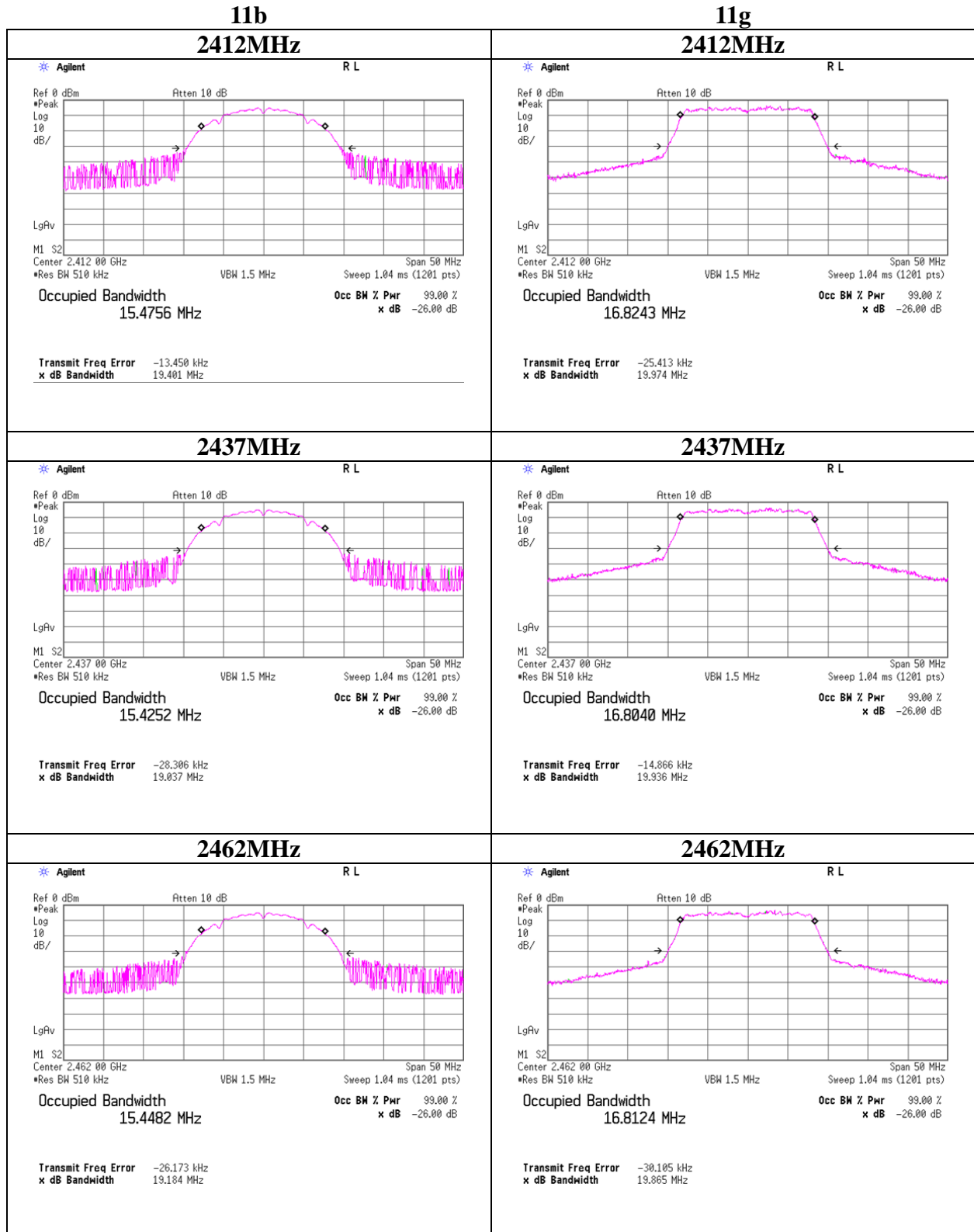

99% Occupied Bandwidth

11n-20

2412MHz

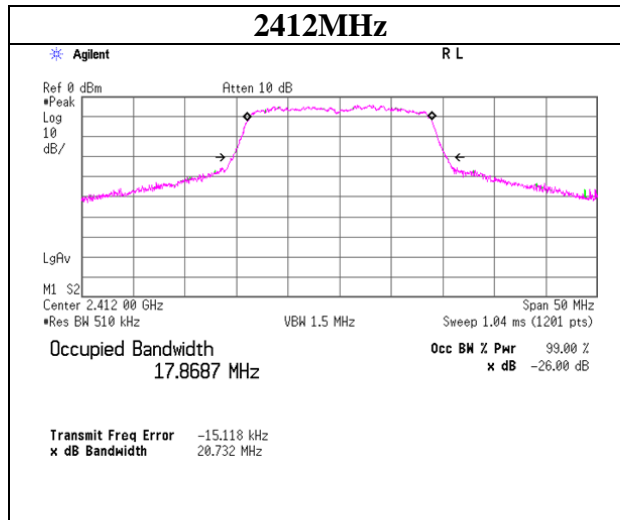

2437MHz

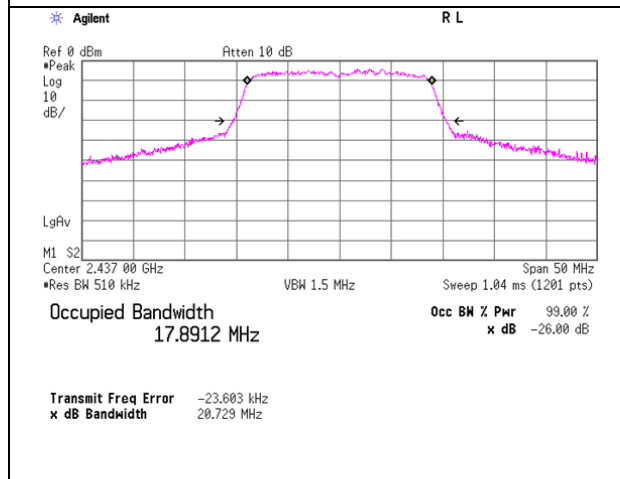

2462MHz

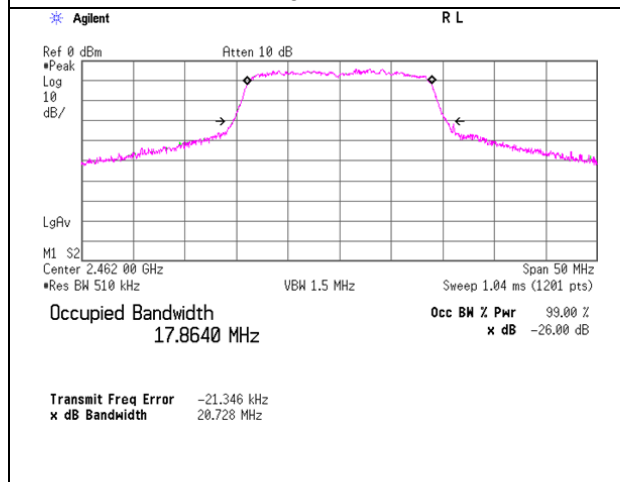

UL Japan, Inc.
Head Office EMC Lab.

4383-326 Asama-cho, Ise-shi, Mie-ken 516-0021 JAPAN

Telephone : +81 596 24 8999

Facsimile : +81 596 24 8124

APPENDIX 2: Test instruments

EMI test equipment (1/2)

Control No.	Instrument	Manufacturer	Model No	Serial No	Test Item	Calibration Date * Interval(month)
COTS-MEMI	EMI measurement program	TSJ	TEPTO-DV	-	RE	-
MAEC-02	Semi Anechoic Chamber(NSA)	TDK	Semi Anechoic Chamber 3m	DA-06902	RE	2012/06/29 * 12
MAEC-04	Semi Anechoic Chamber(NSA)	TDK	Semi Anechoic Chamber 3m	DA-10005	RE	2013/02/28 * 12
MAT-07	Attenuator(6dB)	Weinschel Corp	2	BK7970	RE	2012/11/06 * 12
MAT-68	Attenuator	Anritsu	MP721B	6200961025	RE	2012/11/21 * 12
MBA-02	Biconical Antenna	Schwarzbeck	BBA9106	VHA91032008	RE	2012/10/08 * 12
MBA-05	Biconical Antenna	Schwarzbeck	BBA9106	1302	RE	2012/11/18 * 12
MCC-12	Coaxial Cable	Fujikura/Agilent	-	-	RE	2013/02/06 * 12
MCC-132	Microwave Cable	HUBER+SUHNER	SUCOFLEX104	336161/4(1m) / 340639(5m)	RE	2012/09/05 * 12
MCC-141	Microwave Cable	Junkosha	MWX221	1305S002R(1m) / 1204S062(5m)	RE	2013/05/28* 12
MCC-142	Microwave Cable	Junkosha	MWX221	1203S213(1m) / 1204S063(5m)	RE	2013/04/19 * 12
MCC-50	Coaxial Cable	UL Japan	-	-	RE	2012/06/01 * 12
MCC-79	Microwave Cable 1G-26.5GHz	Suhner	SUCOFLEX104	278923/4	RE	2012/12/24 * 12
MHA-02	Horn Antenna 18-26.5GHz	EMCO	3160-09	1265	RE	2013/02/15 * 12
MHA-06	Horn Antenna 1-18GHz	Schwarzbeck	BBHA9120D	254	RE	2013/02/15 * 12
MHA-17	Horn Antenna 15-40GHz	Schwarzbeck	BBHA9170	BBHA9170307	RE	2012/06/27 * 12
MHA-21	Horn Antenna 1-18GHz	Schwarzbeck	BBHA9120D	9120D-557	RE	2012/08/17 * 12
MHF-06	High Pass Filter 3.5-24GHz	TOKIMEC	TF323DCA	601	RE	2013/05/30 * 12
MHF-20	High Pass Filter 3.5-18.0GHz	TOKIMEC	TF323DCC	607	RE	2012/09/12 * 12
MJM-09	Measure	KDS	E19-55	-	RE	-
MJM-14	Measure	KOMELON	KMC-36	-	RE	-
MLA-02	Logperiodic Antenna	Schwarzbeck	USLP9143	201	RE	2012/10/08 * 12
MLA-08	Logperiodic Antenna	Schwarzbeck	UKLP9140-A	N/A	RE	2012/11/18 * 12
MOS-15	Thermo-Hygrometer	Custom	CTH-180	-	RE	2013/02/26 * 12
MOS-22	Thermo-Hygrometer	Custom	CTH-201	0003	RE	2013/2/26 * 12
MPA-09	Pre Amplifier	Agilent	8447D	2944A10845	RE	2012/09/11 * 12
MPA-10	Pre Amplifier	Agilent	8449B	3008A02142	RE	2013/01/10 * 12
MPA-12	MicroWave System Amplifier	Agilent	83017A	MY39500780	RE	2013/03/19 * 12
MPA-13	Pre Amplifier	SONOMA INSTRUMENT	310	260834	RE	2013/03/12 * 12
MSA-03	Spectrum Analyzer	Agilent	E4448A	MY44020357	RE	2012/11/20 * 12
MSA-04	Spectrum Analyzer	Agilent	E4448A	US44300523	RE	2013/04/03 * 12
MTR-03	Test Receiver	Rohde & Schwarz	ESCI	100300	RE	2013/04/10 * 12
MTR-07	Test Receiver	Rohde & Schwarz	ESCI	100635	RE	2013/04/10 * 12

UL Japan, Inc.

Head Office EMC Lab.

4383-326 Asama-cho, Ise-shi, Mie-ken 516-0021 JAPAN

Telephone : +81 596 24 8999

Facsimile : +81 596 24 8124

EMI test equipment (2/2)

Control No.	Instrument	Manufacturer	Model No	Serial No	Test Item	Calibration Date * Interval(month)
MRENT-95	Spectrum Analyzer	Agilent	E4440A	MY46185823	AT	2012/06/19 * 12
MCC-137	Microwave cable	HUBER+SUHNER	SUCOFLEX 102	37954/2	AT	2012/10/19 * 12
MAT-22	Attenuator(10dB) 1-18GHz	Orient Microwave	BX10-0476-00	-	AT	2013/03/21 * 12
MAT-10	Attenuator(10dB)	Weinschel Corp	2	BL1173	AT	2012/11/06 * 12
MCC-64	Coaxial Cable	UL Japan	-	-	AT	2013/03/22 * 12
MOS-14	Thermo-Hygrometer	Custom	CTH-201	-	AT	2013/02/26 * 12
MPM-08	Power Meter	Anritsu	ML2495A	6K00003338	AT	2012/10/08 * 12
MPSE-11	Power sensor	Anritsu	MA2411B	011737	AT	2012/10/08 * 12
MOS-19	Thermo-Hygrometer	Custom	CTH-201	0001	AT	2012/12/25 * 12
MBA-05	Biconical Antenna	Schwarzbeck	BBA9106	1302	RE	2012/11/18 * 12
MPA-14	Pre Amplifier	SONOMA INSTRUMENT	310	260833	RE	2013/03/12 * 12

The expiration date of the calibration is the end of the expired month.

All equipment is calibrated with valid calibrations. Each measurement data is traceable to the national or international standards.

As for some calibrations performed after the tested dates, those test equipment have been controlled by means of an unbroken chains of calibrations.

Test Item: RE: Radiated Emission

AT: Antenna Terminal Conducted test

UL Japan, Inc.

Head Office EMC Lab.

4383-326 Asama-cho, Ise-shi, Mie-ken 516-0021 JAPAN

Telephone : +81 596 24 8999

Facsimile : +81 596 24 8124