



RADIO TEST REPORT

Test Report No. : 10012781H-A

Applicant : Mitsubishi Electric Co.,Ltd
Type of Equipment : Navigation system
Model No. : NR-241
NR-241UH
NR-243UH
FCC ID : UJHNR241NR243
Test regulation : FCC Part 15 Subpart C: 2013
*Bluetooth part
Test Result : Complied

1. This test report shall not be reproduced in full or partial, without the written approval of UL Japan, Inc.
2. The results in this report apply only to the sample tested.
3. This sample tested is in compliance with the above regulation.
4. The test results in this report are traceable to the national or international standards.
5. This test report must not be used by the customer to claim product certification, approval, or endorsement by NVLAP, NIST, or any agency of the Federal Government.

Date of test: May 21 to June 27, 2013

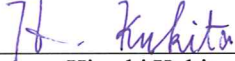
Representative test engineer: 
Hiroshi Kukita
Engineer of WiSE Japan,
UL Verification Service

Approved by: 
Masanori Nishiyama
Manager of WiSE Japan,
UL Verification Service



NVLAP LAB CODE: 200572-0

This laboratory is accredited by the NVLAP LAB CODE 200572-0, U.S.A. The tests reported herein have been performed in accordance with its terms of accreditation.
*As for the range of Accreditation in NVLAP, you may refer to the WEB address,
<http://www.ul.com/japan/jpn/pages/services/emc/about/mark1/index.jsp#nvlap>

UL Japan, Inc.

Head Office EMC Lab.

4383-326 Asama-cho, Ise-shi, Mie-ken 516-0021 JAPAN

Telephone : +81 596 24 8999

Facsimile : +81 596 24 8124

13-EM-F0429

REVISION HISTORY

Original Test Report No.: 10012781H-A

Revision	Test report No.	Date	Page revised	Contents
- (Original)	10012781H-A	July 24, 2013	-	-

CONTENTS	PAGE
SECTION 1: Customer information.....	4
SECTION 2: Equipment under test (E.U.T.).....	4
SECTION 3: Test specification, procedures & results.....	6
SECTION 4: Operation of E.U.T. during testing.....	9
SECTION 5: Radiated Spurious Emission	13
SECTION 6: Antenna Terminal Conducted Tests.....	14
APPENDIX 1: Data of EMI test.....	15
20dB Bandwidth and Carrier Frequency Separation.....	15
Number of Hopping Frequency	18
Dwell time.....	20
Maximum Peak Output Power	23
Radiated Spurious Emission	24
Conducted Spurious Emission	50
Conducted Emission Band Edge compliance	62
99%Occupied Bandwidth	64
APPENDIX 2: Test instruments	66
APPENDIX 3: Photographs of test setup.....	68
Radiated Spurious Emission	68

UL Japan, Inc.

Head Office EMC Lab.

4383-326 Asama-cho, Ise-shi, Mie-ken 516-0021 JAPAN

Telephone : +81 596 24 8999

Facsimile : +81 596 24 8124

SECTION 1: Customer information

Company Name : Mitsubishi Electric Co.,Ltd
Address : 2-3-33, Miwa, Sanda-city, Hyogo, 669-1513, Japan
Telephone Number : +81-79-559-3623
Facsimile Number : +81-79-559-3875
Contact Person : Kenji Otani

SECTION 2: Equipment under test (E.U.T.)

2.1 Identification of E.U.T.

Type of Equipment : Navigation System
Model No. : NR-241
NR-241UH
NR-243UH
Serial No. : Refer to Section 4, Clause 4.2
Rating : DC 13.2V
Receipt Date of Sample : May 14, 2013
Country of Mass-production : Thailand
Condition of EUT : Production prototype
(Not for Sale: This sample is equivalent to mass-produced items.)
Modification of EUT : No Modification by the test lab

2.2 Variant model

Model No. NR-241, NR-241UH, NR-243UH have variant models.
NR-241 has Left handle model and Right handle model.
NR-241UH and NR-243UH have Internal Amplifier model and External Amplifier model.
Above models were tested. Please refer to Section 4.1 for details.

UL Japan, Inc.

Head Office EMC Lab.

4383-326 Asama-cho, Ise-shi, Mie-ken 516-0021 JAPAN
Telephone : +81 596 24 8999
Facsimile : +81 596 24 8124

2.2 Product Description

General Specification

Clock frequency(ies) in the system : 800MHz

Radio Specification

[WLAN (IEEE802.11b/g/n-20)]

Radio Type : Transceiver
Frequency of Operation : 2412-2462MHz
Modulation : DSSS, OFDM
Power Supply (inner) : DC 3.3V
Antenna type : Inverted F Antenna
Antenna Gain : -1.89dBi

[Bluetooth (Ver. 3.0 with EDR function)]

Radio Type : Transceiver
Frequency of Operation : 2402-2480MHz
Modulation : FHSS
Power Supply (inner) : DC 3.3V
Antenna type : Inverted F Antenna
Antenna Gain : 0.40dBi

[GPS]

Radio Type : Receiver
Frequency of Operation : 1575.42MHz
Modulation : CDMA
Power Supply (radio part input) : DC 3.3V
Antenna type : Inverted F Antenna
Antenna Gain : 0dBi

*Co-location EMC tests were skipped based on FCC EMC co-location test policy of TCB workshop 2005 May, because it will be deemed that the compliance can be presumed under this filing condition by manufacturer declaration.

UL Japan, Inc.

Head Office EMC Lab.

4383-326 Asama-cho, Ise-shi, Mie-ken 516-0021 JAPAN

Telephone : +81 596 24 8999

Facsimile : +81 596 24 8124

SECTION 3: Test specification, procedures & results

3.1 Test Specification

Test Specification : FCC Part 15 Subpart C: 2013, final revised on June 11, 2013 and effective July 11, 2013

Title : FCC 47CFR Part15 Radio Frequency Device Subpart C Intentional Radiators
Section 15.207 Conducted limits
Section 15.247 Operation within the bands 902-928MHz,
2400-2483.5MHz, and 5725-5850MHz

* The revision on June 11, 2013 does not affect the test specification applied to the EUT.

3.2 Procedures and results

Item	Test Procedure	Specification	Worst Margin	Results	Remarks
Conducted Emission	FCC: ANSI C63.4:2003 7. AC powerline conducted emission measurements IC: RSS-Gen 7.2.4	FCC: Section 15.207 ----- IC: RSS-Gen 7.2.4		N/A	*1)
Carrier Frequency Separation	FCC: FCC Public Notice DA 00-705 ----- IC: -	FCC: Section15.247(a)(1) ----- IC: RSS-210 A8.1 (b)		Complied	Conducted
20dB Bandwidth	FCC: FCC Public Notice DA 00-705 ----- IC: -	FCC: Section15.247(a)(1) ----- IC: RSS-210 A8.1 (a)		Complied	Conducted
Number of Hopping Frequency	FCC: FCC Public Notice DA 00-705 ----- IC: -	FCC: Section15.247(a)(1)(iii) ----- IC: RSS-210 A8.1 (d)	See data.	Complied	Conducted
Dwell time	FCC: FCC Public Notice DA 00-705 ----- IC: -	FCC: Section15.247(a)(1)(iii) ----- IC: RSS-210 A8.1 (d)		Complied	Conducted
Maximum Peak Output Power	FCC: FCC Public Notice DA 00-705 ----- IC: RSS-Gen 4.8	FCC: Section15.247 (b)(1) ----- IC: RSS-210 A8.4 (2)		Complied	Conducted
Spurious Emission & Band Edge Compliance	FCC: FCC Public Notice DA 00-705 ----- IC: RSS-Gen 4.9	FCC: Section15.247(d) ----- IC: RSS-210 A8.5 RSS-Gen 6 and 7.2.3	6.2dB 2822.315MHz, AV, Hori.	Complied	Conducted/ Radiated

Note: UL Japan, Inc.'s EMI Work Procedures No. 13-EM-W0420 and 13-EM-W0422.

*1) The test is not applicable since the EUT is not the device that is designed to be connected to the public utility (AC) power line.

* In case any questions arise about test procedure, ANSI C63.4: 2003 is also referred.

UL Japan, Inc.

Head Office EMC Lab.

4383-326 Asama-cho, Ise-shi, Mie-ken 516-0021 JAPAN

Telephone : +81 596 24 8999

Facsimile : +81 596 24 8124

FCC 15.31 (e)

The EUT is a battery-operated device and test was performed with the full-charged battery voltage. Therefore, this EUT complies with the requirement.

FCC Part 15.203 Antenna requirement

It is impossible for end users to replace the antenna, because the antenna is mounted inside of the EUT. Therefore, the equipment complies with the antenna requirement of Section 15.203.

3.3 Addition to standard

Item	Test Procedure	Specification	Worst margin	Results	Remarks
99% Occupied Bandwidth	IC: RSS-Gen 4.6.1	IC: RSS-Gen 4.6.1	N/A	-	Conducted

Other than above, no addition, exclusion nor deviation has been made from the standard.

3.4 Uncertainty

EMI

The following uncertainties have been calculated to provide a confidence level of 95% using a coverage factor k=2.

Test room (semi-anechoic chamber)	Radiated emission						
	(3m*)(+dB)				(1m*)(+dB)		(0.5m*)(+dB)
	9kHz -30MHz	30MHz -300MHz	300MHz -1GHz	1GHz -10GHz	10GHz -18GHz	18GHz -26.5GHz	26.5GHz -40GHz
No.1	4.3dB	5.0dB	5.1dB	4.9dB	5.8dB	4.4dB	4.3dB
No.2	4.3dB	5.2dB	5.1dB	5.0dB	5.7dB	4.3dB	4.2dB
No.3	4.6dB	5.0dB	5.1dB	5.0dB	5.7dB	4.5dB	4.2dB
No.4	4.8dB	5.2dB	5.0dB	5.0dB	5.7dB	5.2dB	4.2dB

*3m/1m/0.5m = Measurement distance

Power meter (+dB)	
Below 1GHz	Above 1GHz
0.7dB	1.5dB

Antenna terminal conducted emission and Power density (+dB)			Antenna terminal conducted emission (+dB)		Channel power (+dB)
Below 1GHz	1GHz-3GHz	3GHz-18GHz	18GHz-26.5GHz	26.5GHz-40GHz	
1.5dB	1.7dB	2.8dB	2.8dB	2.9dB	2.6dB

Radiated emission test(3m)

The data listed in this test report has enough margin, more than the site margin.

UL Japan, Inc.

Head Office EMC Lab.

4383-326 Asama-cho, Ise-shi, Mie-ken 516-0021 JAPAN

Telephone : +81 596 24 8999

Facsimile : +81 596 24 8124

3.5 Test Location

UL Japan, Inc. Head Office EMC Lab. *NVLAP Lab. code: 200572-0
4383-326 Asama-cho, Ise-shi, Mie-ken 516-0021 JAPAN
Telephone : +81 596 24 8999 Facsimile : +81 596 24 8124

	FCC Registration Number	IC Registration Number	Width x Depth x Height (m)	Size of reference ground plane (m) / horizontal conducting plane	Other rooms
No.1 semi-anechoic chamber	313583	2973C-1	19.2 x 11.2 x 7.7m	7.0 x 6.0m	No.1 Power source room
No.2 semi-anechoic chamber	655103	2973C-2	7.5 x 5.8 x 5.2m	4.0 x 4.0m	-
No.3 semi-anechoic chamber	148738	2973C-3	12.0 x 8.5 x 5.9m	6.8 x 5.75m	No.3 Preparation room
No.3 shielded room	-	-	4.0 x 6.0 x 2.7m	N/A	-
No.4 semi-anechoic chamber	134570	2973C-4	12.0 x 8.5 x 5.9m	6.8 x 5.75m	No.4 Preparation room
No.4 shielded room	-	-	4.0 x 6.0 x 2.7m	N/A	-
No.5 semi-anechoic chamber	-	-	6.0 x 6.0 x 3.9m	6.0 x 6.0m	-
No.6 shielded room	-	-	4.0 x 4.5 x 2.7m	4.75 x 5.4 m	-
No.6 measurement room	-	-	4.75 x 5.4 x 3.0m	4.75 x 4.15 m	-
No.7 shielded room	-	-	4.7 x 7.5 x 2.7m	4.7 x 7.5m	-
No.8 measurement room	-	-	3.1 x 5.0 x 2.7m	N/A	-
No.9 measurement room	-	-	8.0 x 4.5 x 2.8m	2.0 x 2.0m	-
No.10 measurement room	-	-	2.6 x 2.8 x 2.5m	2.4 x 2.4m	-
No.11 measurement room	-	-	3.1 x 3.4 x 3.0m	2.4 x 3.4m	-

* Size of vertical conducting plane (for Conducted Emission test) : 2.0 x 2.0m for No.1, No.2, No.3, and No.4 semi-anechoic chambers and No.3 and No.4 shielded rooms.

3.6 Data of EMI, Test instruments, and Test set up

Refer to APPENDIX.

UL Japan, Inc.

Head Office EMC Lab.

4383-326 Asama-cho, Ise-shi, Mie-ken 516-0021 JAPAN
Telephone : +81 596 24 8999
Facsimile : +81 596 24 8124

SECTION 4: Operation of E.U.T. during testing

4.1 Operating Mode(s)

Bluetooth (BT): Transmitting (Tx), Payload: PRBS9
Inquiry

Details of Operating Mode(s)

Test Item	Mode	Tested frequency
Spurious Emission (Conducted/Radiated)	Tx (Hopping off) DH5, 3DH5	2402MHz 2441MHz 2480MHz
Carrier Frequency Separation	Tx (Hopping on) DH5, 3DH5 Inquiry	2402MHz 2441MHz 2480MHz
20dB Bandwidth	Tx (Hopping off) DH5, 3DH5 Inquiry	2402MHz 2441MHz 2480MHz
Number of Hopping Frequency	Tx (Hopping on) DH5, 3DH5 Inquiry	-
Dwell time	Tx (Hopping on), -DH1, DH3, DH5 -3DH1, 3DH3, 3DH5 Inquiry	-
Maximum Peak Output Power	Tx (Hopping off) DH5, 2DH5, 3DH5 Inquiry	2402MHz 2441MHz 2480MHz
Band Edge Compliance (Conducted)	Tx DH5, 3DH5 -Hopping on -Hopping off	2402MHz 2480MHz
99% Occupied Bandwidth	Tx DH5, 3DH5 -Hopping on -Hopping off Inquiry	2402MHz 2441MHz 2480MHz
<p>*As a result of preliminary test, the formal test was performed with the above modes, which had the maximum payload length (except Dwell time test) *EUT has the power settings by the software as follows; Power settings: 0dBm Software: 1.0 *This setting of software is the worst case. Any conditions under the normal use do not exceed the condition of setting. In addition, end users cannot change the settings of the output power of the product.</p>		

UL Japan, Inc.

Head Office EMC Lab.

4383-326 Asama-cho, Ise-shi, Mie-ken 516-0021 JAPAN

Telephone : +81 596 24 8999

Facsimile : +81 596 24 8124

Details of tested models

	NR-241 (Left handle)	NR-241 (Right handle)	NR-243UH (Internal Amplifier)	NR-241UH (Internal Amplifier)	NR-241UH (External Amplifier)	NR-243UH (External Amplifier)
Antenna terminal conducted	X *1)	-	-	-	-	-
Spurious Emission (Radiated)	X	X	X	X	X	X
	[DH5] 2402MHz 2441MHz 2480MHz [3DH5] 2402MHz 2441MHz 2480MHz	[DH5] 2402MHz 2441MHz 2480MHz *2)	[DH5] 2402MHz 2441MHz 2480MHz [3DH5] 2402MHz 2441MHz 2480MHz	[DH5] 2402MHz 2441MHz 2480MHz *2)	[DH5] 2402MHz 2441MHz 2480MHz *2)	[DH5] 2402MHz 2441MHz 2480MHz *2)

*1) This model was tested as a representative because the above models embedded same module.

*2) The test was performed on the mode that has the worst condition in model No.: NR-241(Left handle) according to the customer's request.

UL Japan, Inc.

Head Office EMC Lab.

4383-326 Asama-cho, Ise-shi, Mie-ken 516-0021 JAPAN

Telephone : +81 596 24 8999

Facsimile : +81 596 24 8124

4.2 Configuration and peripherals

[Model No.: NR-241 (Left handle), NR-241 (Right handle), NR-243UH (Internal Amplifier), NR-241UH4CC00-T (Internal Amplifier)]

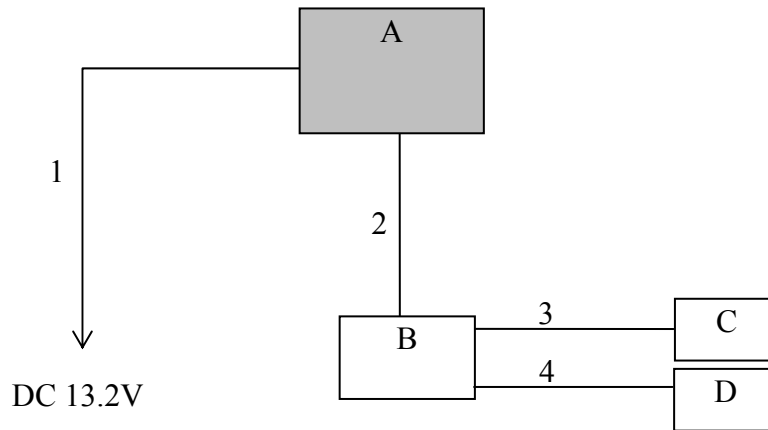

[Model No.: NR-241UH4CC50-T (External Amplifier), NR-243UH4CCF0-T (External Amplifier)]

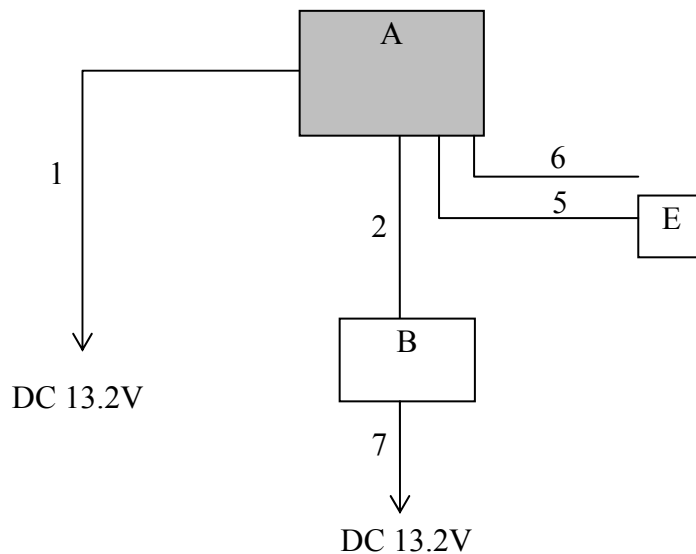

* Cabling and setup were taken into consideration and test data was taken under worse case conditions.

UL Japan, Inc.

Head Office EMC Lab.

4383-326 Asama-cho, Ise-shi, Mie-ken 516-0021 JAPAN

Telephone : +81 596 24 8999

Facsimile : +81 596 24 8124

Description of EUT

No.	Item	Model number	Serial number	Manufacturer	Remark
A	Navigation System	NR-241 (Left handle)	934H6012 *1) 934H6009 *2)	Mitsubishi Electric Co.,Ltd	EUT
		NR-241 (Right handle)	935B6001		
		NR-243UH (Internal Amplifier)	93527045		
		NR-241UH (Internal Amplifier)	934R7039		
		NR-241UH (External Amplifier)	934R7009		
		NR-243UH (External Amplifier)	934Q7003		
B	Jig board	-	-	-	-
C	Speaker	TS-STX5		PIONEER	-
D	Speaker	TS-STX5	FM0847	PIONEER	-
E	GPS Antenna	-	-	-	-

*1) Used for Radiated Spurious Emission test

*2) Used for Antenna Terminal Conducted tests

List of cables used

No.	Name	Length (m)	Shield	
			Cable	Connector
1	DC Cable	3.3	Unshielded	Unshielded
2	Signal Cable	1.8	Unshielded	Unshielded
3	Speaker Cable	0.5	Unshielded	Unshielded
4	Speaker Cable	0.5	Unshielded	Unshielded
5	Antenna Cable	3.0	Shielded	Shielded
6	Signal Cable	2.0	Unshielded	Unshielded
7	DC Cable	2.0	Unshielded	Unshielded

UL Japan, Inc.

Head Office EMC Lab.

4383-326 Asama-cho, Ise-shi, Mie-ken 516-0021 JAPAN

Telephone : +81 596 24 8999

Facsimile : +81 596 24 8124

SECTION 5: Radiated Spurious Emission

Test Procedure

EUT was placed on a urethane platform of nominal size, 1.0m by 1.5m, raised 0.8m above the conducting ground plane.

The Radiated Electric Field Strength has been measured in a Semi Anechoic Chamber with a ground plane.

The height of the measuring antenna varied between 1 and 4m and EUT was rotated a full revolution in order to obtain the maximum value of the electric field strength.

The measurements were performed for both vertical and horizontal antenna polarization with the Test Receiver, or the Spectrum Analyzer.

The measurements were made with the following detector function of the test receiver and the Spectrum analyzer (in linear mode).

The test was made with the detector (RBW/VBW) in the following table.

When using Spectrum analyzer, the test was made with adjusting span to zero by using peak hold.

Test Antennas are used as below;

Frequency	Below 30MHz	30MHz to 300MHz	300MHz to 1GHz	Above 1GHz
Antenna Type	Loop	Biconical	Logperiodic	Horn

In any 100kHz bandwidth outside the restricted band in which the spread spectrum intentional radiator is operating, the radio frequency power that is produced by the intentional radiator confirmed 20dB below that in the 100kHz bandwidth within the band that contains the highest level of the desired power, based on a radiated measurement.

20dBc was applied to the frequency over the limit of FCC 15.209 / Table 5 of RSS-Gen 7.2.5 (IC) and outside the restricted band of FCC15.205 / Table 3 of RSS-Gen 7.2.2 (IC).

Frequency	Below 1GHz	Above 1GHz		20dBc
Instrument used	Test Receiver	Spectrum Analyzer		Spectrum Analyzer
Detector	QP	PK	AV	PK
IF Bandwidth	BW 120kHz(T/R)	RBW: 1MHz VBW: 3MHz	RBW: 1MHz VBW: 10Hz *1)	RBW: 100kHz VBW: 300kHz (S/A)
Test Distance	3m	3m (below 10GHz), 1m*2) (above 10GHz)		3m (below 10GHz), 1m*2) (above 10GHz)

*1) Although 00-705 accepts VBW=10Hz for AV measurements, it was confirmed that superfluous smoothing was not performed.”

*2) Distance Factor: $20 \times \log(3.0\text{m}/1.0\text{m}) = 9.5\text{dB}$

The test was made on EUT at the normal use position.

The test results and limit are rounded off to one decimal place, so some differences might be observed.

Measurement range : 30M-26.5GHz
Test data : APPENDIX
Test result : Pass

UL Japan, Inc.

Head Office EMC Lab.

4383-326 Asama-cho, Ise-shi, Mie-ken 516-0021 JAPAN

Telephone : +81 596 24 8999

Facsimile : +81 596 24 8124

SECTION 6: Antenna Terminal Conducted Tests

Test Procedure

The tests were made with below setting connected to the antenna port.

Test	Span	RBW	VBW	Sweep time	Detector	Trace	Instrument used
20dB Bandwidth	3MHz	30kHz	100kHz	Auto	Peak	Max Hold	Spectrum Analyzer
99% Occupied Bandwidth	Enough width to display 20dB Bandwidth	1 to 3% of Span	Three times of RBW	Auto	Peak	Max Hold *1)	Spectrum Analyzer
Maximum Peak Output Power	-	-	-	Auto	Peak	-	Power Meter (Sensor: 50MHz BW)
Carrier Frequency Separation	5MHz or 3MHz	30kHz	100kHz	Auto	Peak	Max Hold	Spectrum Analyzer
Number of Hopping Frequency	30MHz	300kHz	1MHz	Auto	Peak	Max Hold	Spectrum Analyzer
Dwell Time	Zero Span	100kHz, 1MHz	300kHz, 3MHz	As necessary capture the entire dwell time per hopping channel	Peak	Max Hold	Spectrum Analyzer
Conducted Spurious Emission *2)	9kHz to 150kHz	200Hz	620Hz	Auto	Peak	Max Hold	Spectrum Analyzer
	150kHz to 30MHz	9.1kHz	27kHz				
	30MHz to 25GHz (Less or equal to 5GHz)	100kHz	300kHz				
Conducted Spurious Emission Band Edge compliance	10MHz	100kHz	300kHz	Auto	Peak	Max Hold	Spectrum Analyzer

*1) The measurement was performed with Max Hold since the duty cycle was not 100%.
*2) In the frequency range below 30MHz, RBW was narrowed to separate the noise contents.
Then, wide-band noise near the limit was checked separately, however the noise was not detected as shown in the chart.(9kHz-150kHz:RBW=200Hz, 150kHz-30MHz:RBW=9.1kHz)

The test results and limit are rounded off to two decimals place, so some differences might be observed.

Test data : APPENDIX
Test result : Pass

UL Japan, Inc.

Head Office EMC Lab.

4383-326 Asama-cho, Ise-shi, Mie-ken 516-0021 JAPAN

Telephone : +81 596 24 8999

Facsimile : +81 596 24 8124

APPENDIX 1: Data of EMI test

20dB Bandwidth and Carrier Frequency Separation

Test place : Head Office EMC Lab. No.11 Measurement Room
Report No. : 10012781H
Date : May 21, 2013
Temperature/ Humidity : 23 deg. C / 68% RH
Engineer : Takumi Shimada
Mode : Tx (Hopping on) DH5/3DH5/Inquiry

Mode	Freq. [MHz]	20dB Bandwidth [MHz]	Carrier Frequency Separation [MHz]	Limit for Carrier Frequency separation [MHz]
DH5	2402.0	0.960	1.000	≧ 0.640
DH5	2441.0	0.961	1.000	≧ 0.641
DH5	2480.0	0.961	1.000	≧ 0.641
3DH5	2402.0	1.293	1.000	≧ 0.862
3DH5	2441.0	1.293	1.000	≧ 0.862
3DH5	2480.0	1.299	1.000	≧ 0.866
Inquiry	2441.0	0.808	2.000	≧ 0.538

Limit: Two-thirds of 20dB Bandwidth or 25kHz (whichever is greater).
No limit applies to 20dB Bandwidth.

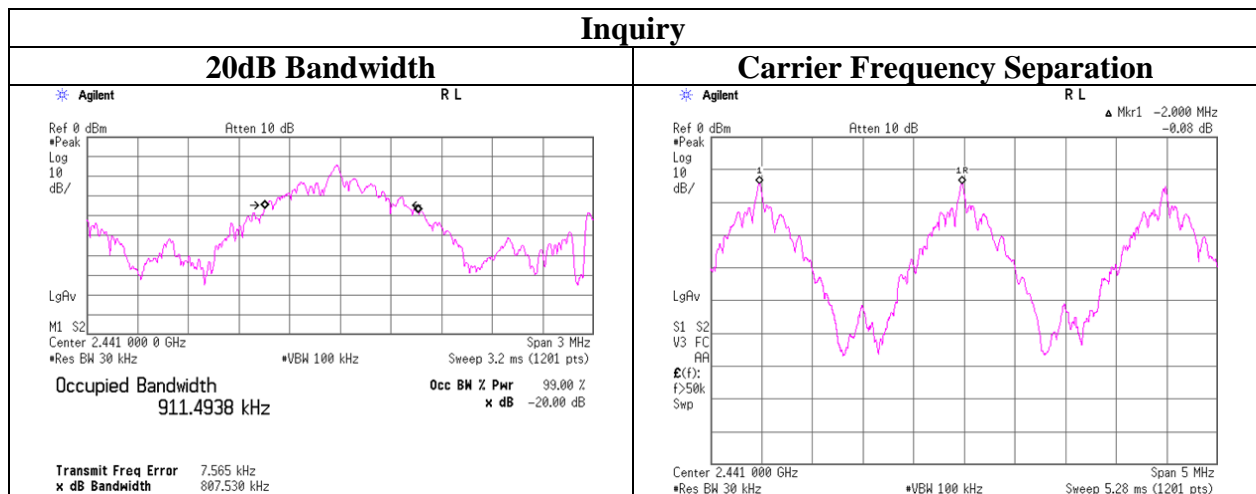

20dB Bandwidth and Carrier Frequency Separation

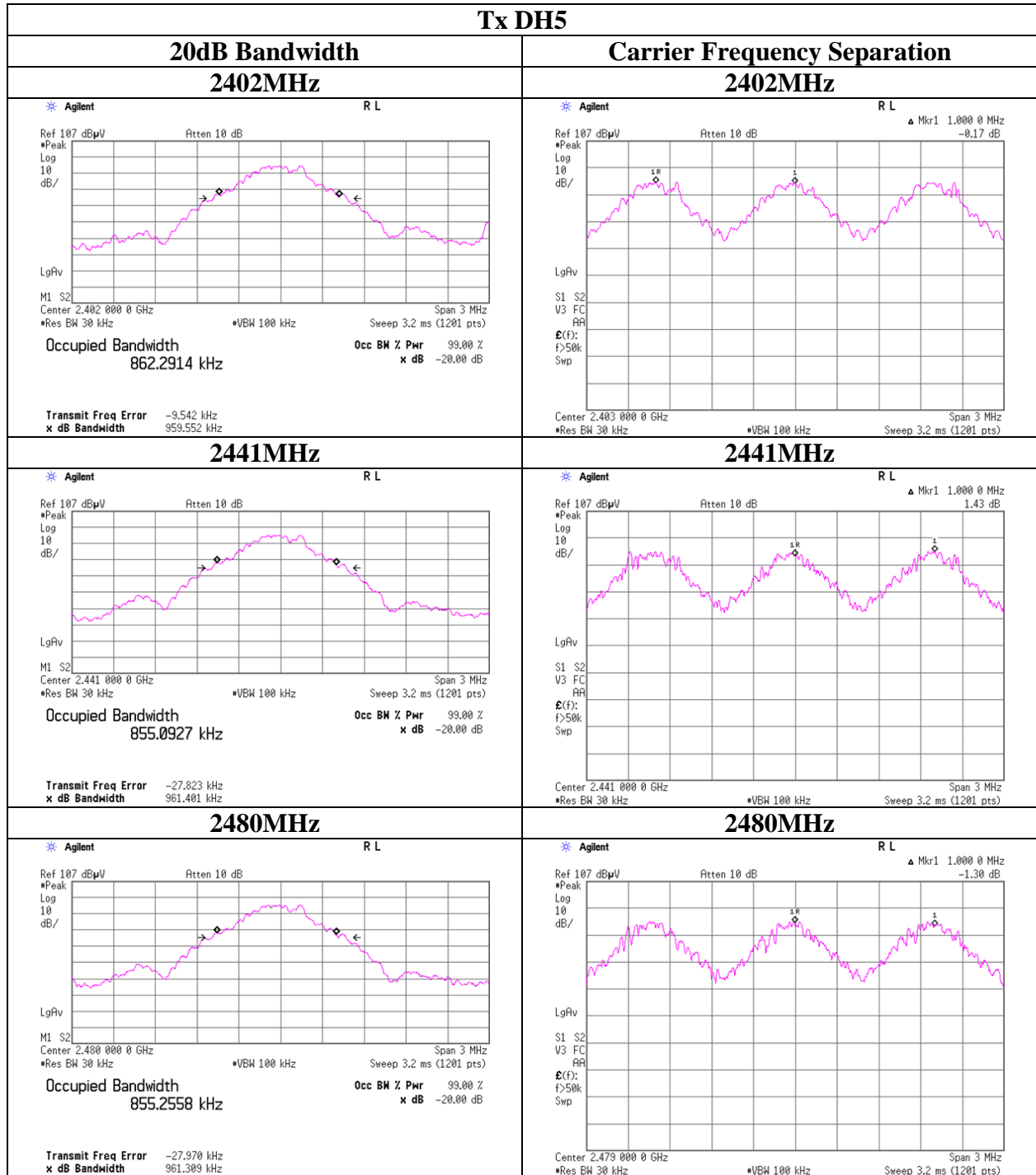

20dB Bandwidth and Carrier Frequency Separation

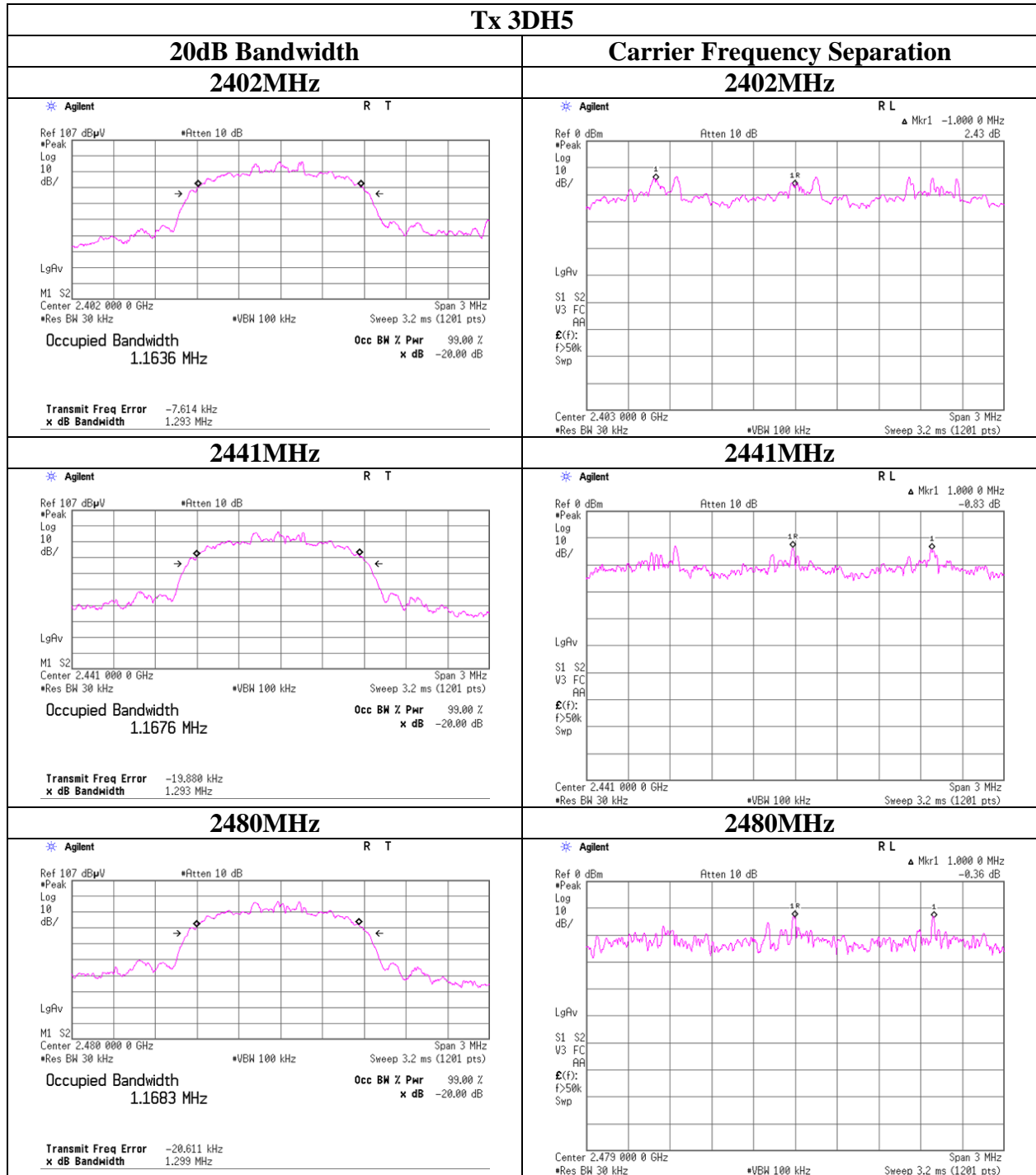

Number of Hopping Frequency

Test place	Head Office EMC Lab. No.11 Measurement Room
Report No.	10012781H
Date	May 21, 2013
Temperature/ Humidity	23 deg.C/ 68% RH
Engineer	Takumi Shimada
Mode	Tx (Hopping on) DH5/3DH5/Inquiry

Mode	Number of channel [times]	Limit [times]
DH5	79	>= 15
3DH5	79	>= 15
Inquiry	32	>= 15

Test was not performed at AFH mode whose number of hopping channel is 20 channels because this Bluetooth radio is in compliance of Bluetooth Specification.

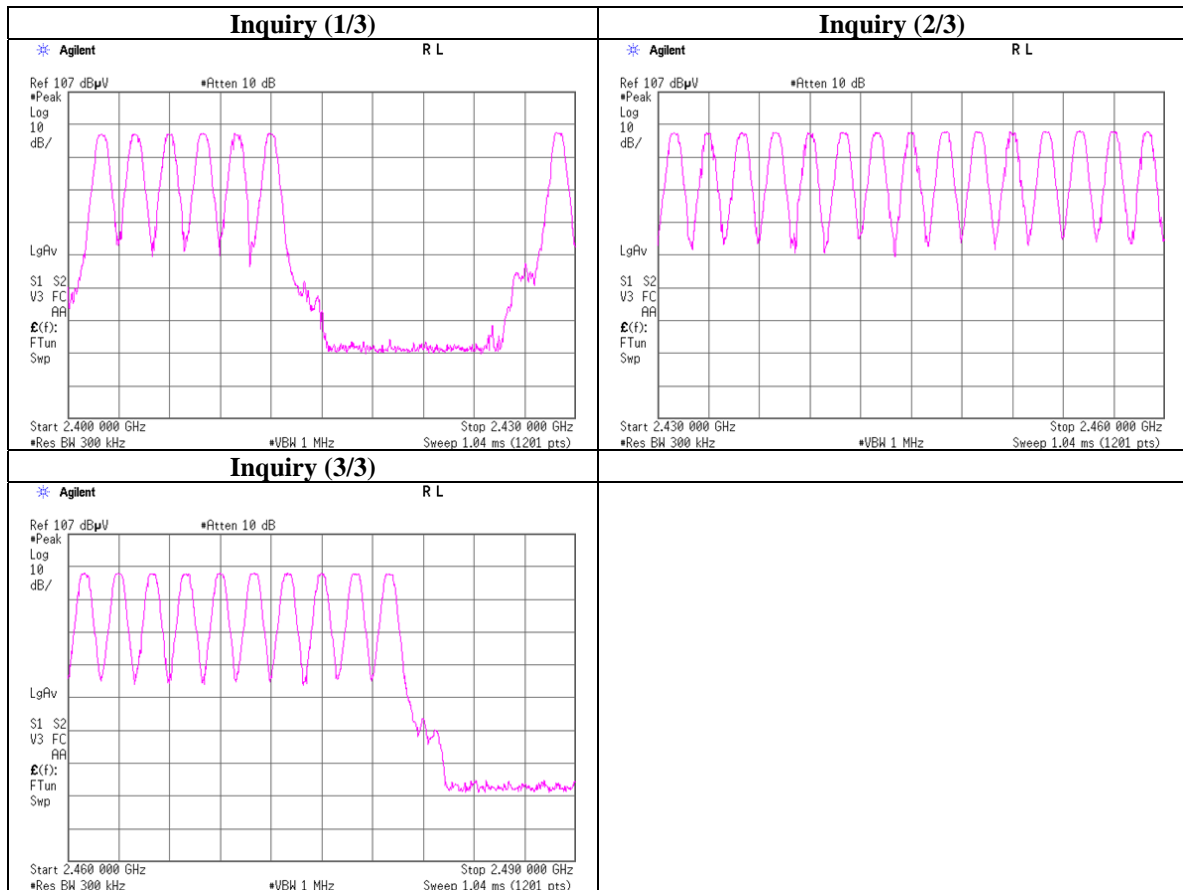

Number of Hopping Frequency

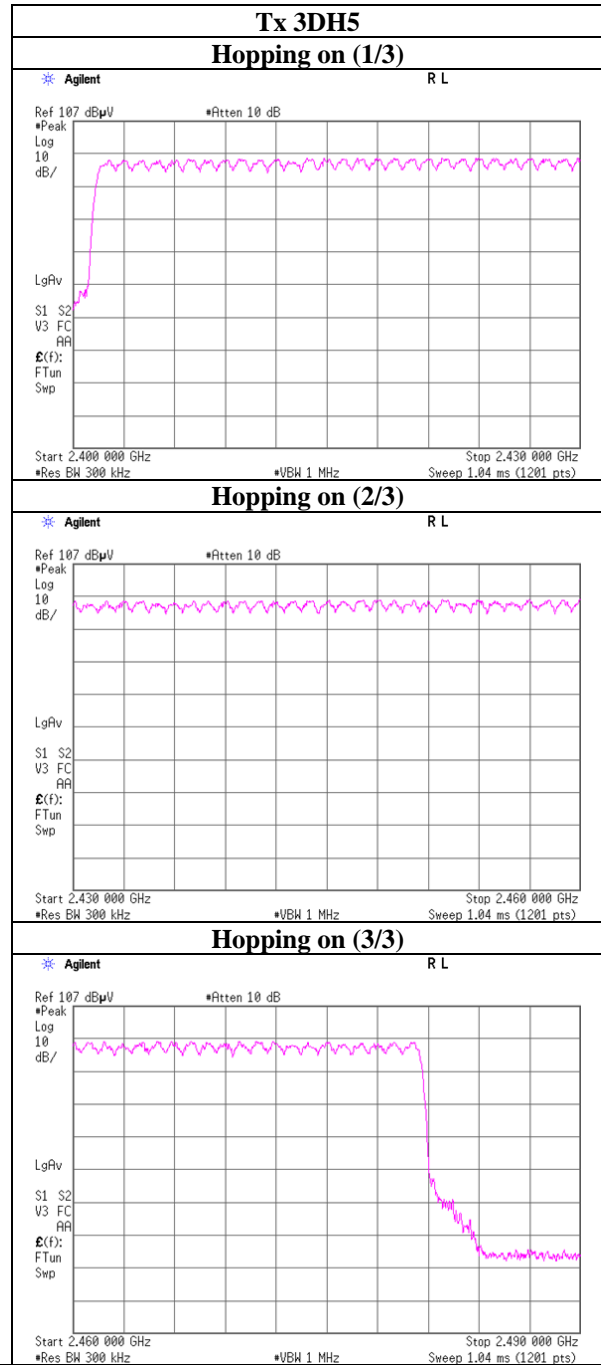
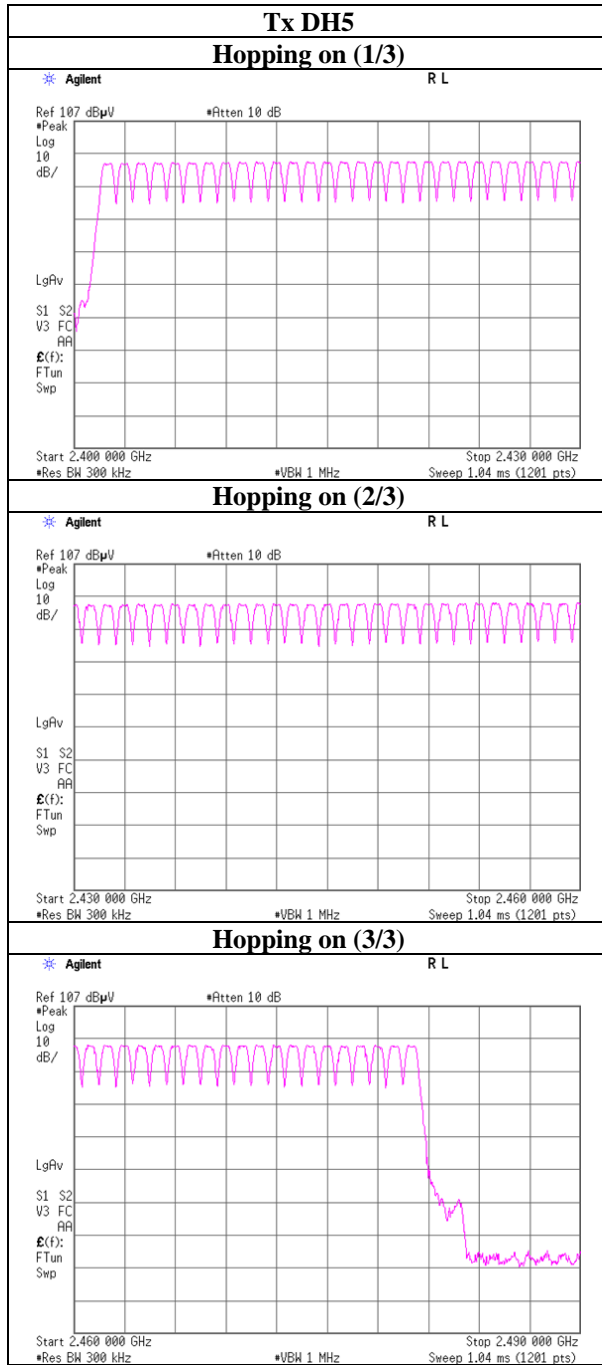

Dwell time

Test place	Head Office EMC Lab. No.11 Measurement Room
Report No.	10012781H
Date	May 21, 2013
Temperature/ Humidity	23 deg.C/ 68% RH
Engineer	Takumi Shimada
Mode	Tx (Hopping on) DH5/3DH5/Inquiry

Mode	Number of transmission in a 31.6(79 Hopping x 0.4) / 12.8(32 Hopping x 0.4)second period	Length of transmission time [msec]	Result [msec]	Limit [msec]
DH1	50.4 times / 5 sec. x 31.6 sec. = 319 times	0.418	133	400
DH3	25.6 times / 5 sec. x 31.6 sec. = 162 times	1.695	275	400
DH5	17.2 times / 5 sec. x 31.6 sec. = 109 times	2.933	320	400
3DH1	50.2 times / 5 sec. x 31.6 sec. = 318 times	0.437	139	400
3DH3	25.2 times / 5 sec. x 31.6 sec. = 160 times	1.685	270	400
3DH5	17.2 times / 5 sec. x 31.6 sec. = 109 times	2.947	321	400
Inquiry	100.0 times / 1 sec. x 12.8 sec. = 1280 times	0.118	151	400

Sample Calculation

Result = Number of transmission x Length of transmission time

*Average data of 5 tests.(except Inquiry)

Mode	Sampling [times]					Average [times]
	1	2	3	4	5	
DH1	50	50	51	50	51	50.4
DH3	25	26	26	25	26	25.6
DH5	17	17	17	18	17	17.2
3DH1	50	51	50	50	50	50.2
3DH3	25	25	25	26	25	25.2
3DH5	17	17	18	17	17	17.2

Sample Calculation

Average= Summation(Sampling 1 to 5) / 5

This device complies with the Bluetooth protocol for FHSS operation, employing a pseudo random channel selection and hopping rate to ensure that the occupancy time in $N \times 0.4s$, where N is the number of channels being used in the hopping sequence ($20 \leq N \leq 79$), is always less than 0.4s regardless of packet size. This is confirmed in the test report for $N=79$.

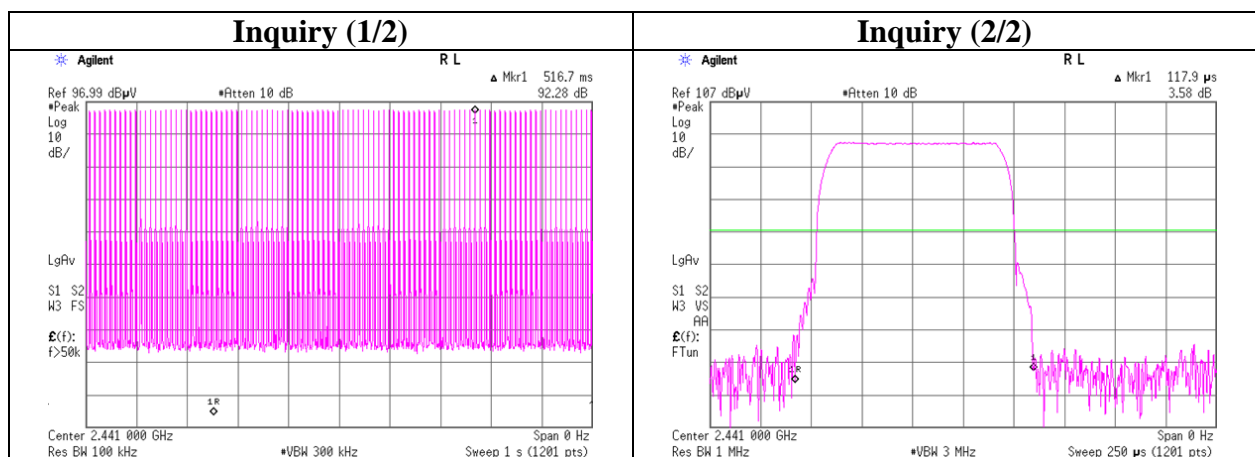

UL Japan, Inc.

Head Office EMC Lab.

4383-326 Asama-cho, Ise-shi, Mie-ken 516-0021 JAPAN

Telephone : +81 596 24 8999

Facsimile : +81 596 24 8124

Dwell time

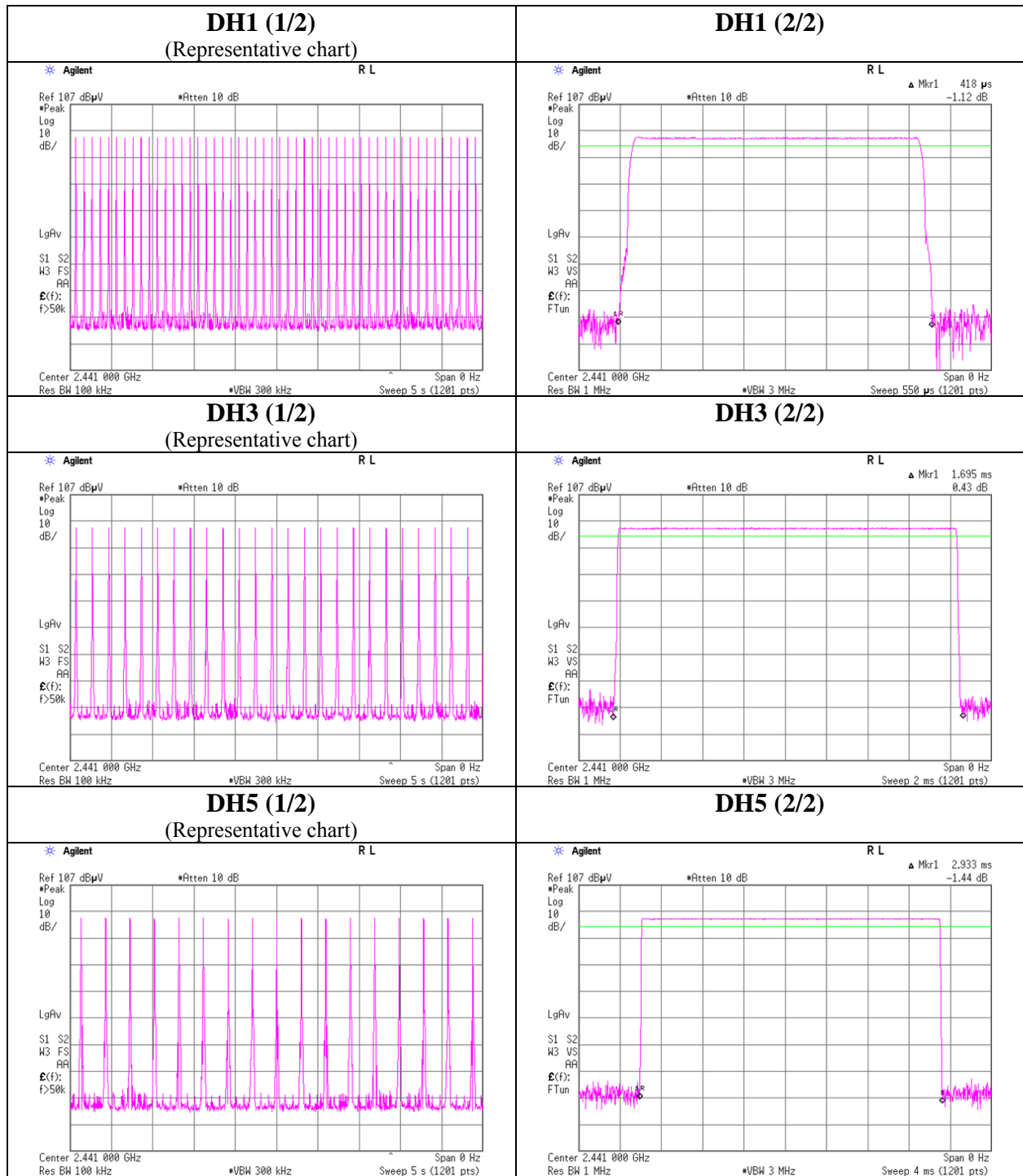

UL Japan, Inc.

Head Office EMC Lab.

4383-326 Asama-cho, Ise-shi, Mie-ken 516-0021 JAPAN

Telephone : +81 596 24 8999

Facsimile : +81 596 24 8124

Dwell time

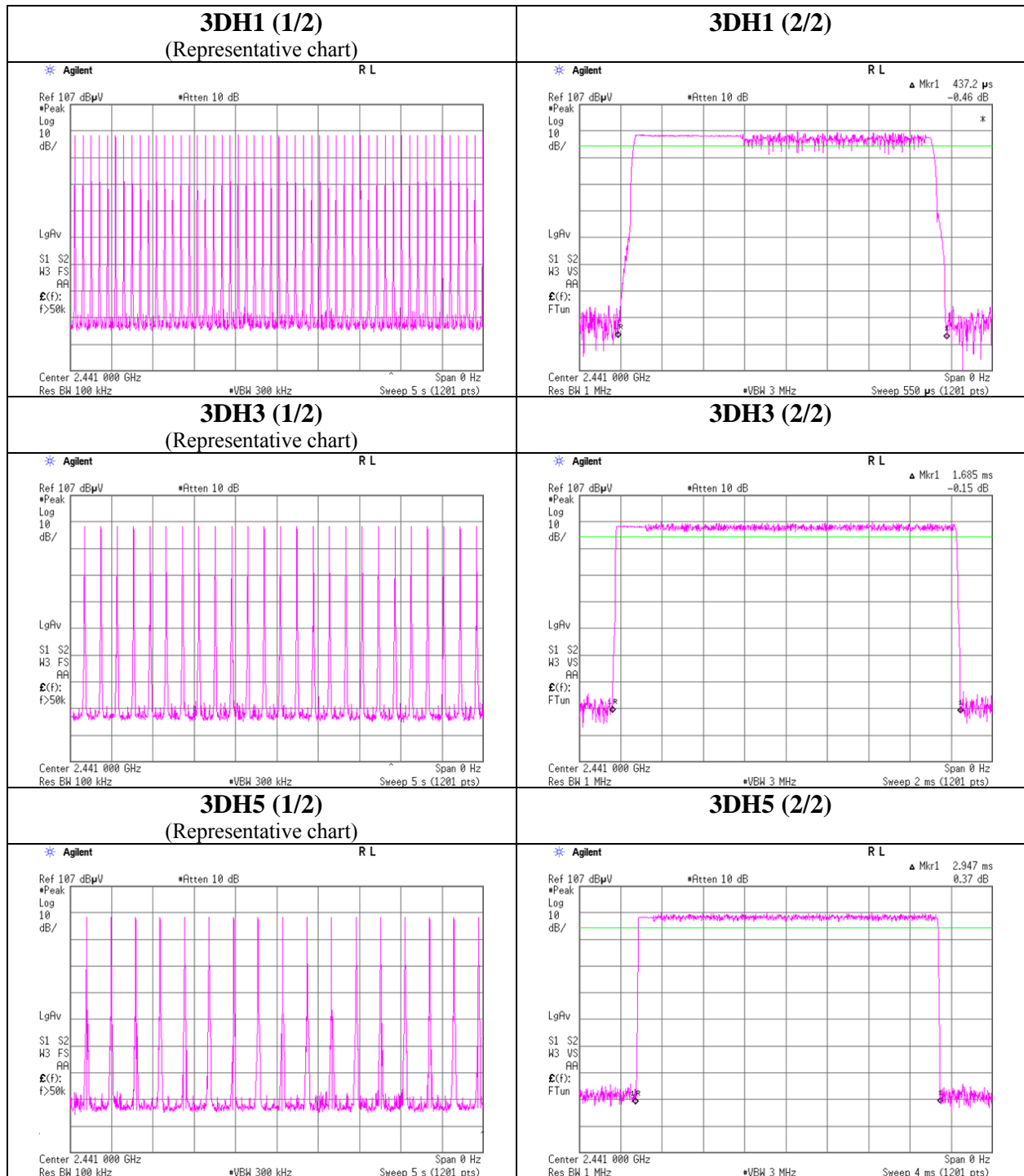

UL Japan, Inc.

Head Office EMC Lab.

4383-326 Asama-cho, Ise-shi, Mie-ken 516-0021 JAPAN

Telephone : +81 596 24 8999

Facsimile : +81 596 24 8124

Maximum Peak Output Power

Test place	Head Office EMC Lab. No.11 Measurement Room
Report No.	10012781H
Date	May 21, 2013
Temperature/ Humidity	23 deg.C/ 68% RH
Engineer	Takumi Shimada
Mode	Tx (Hopping on) DH5/3DH5/Inquiry

Mode	Freq. [MHz]	Reading [dBm]	Cable Loss [dB]	Atten. [dB]	Result		Limit		Margin [dB]
					[dBm]	[mW]	[dBm]	[mW]	
DH5	2402.0	-10.66	0.50	10.01	-0.15	0.97	20.96	125	21.11
DH5	2441.0	-11.10	0.50	10.01	-0.59	0.87	20.96	125	21.55
DH5	2480.0	-10.91	0.50	10.01	-0.40	0.91	20.96	125	21.36
2DH5	2402.0	-9.75	0.50	10.01	0.76	1.19	20.96	125	20.20
2DH5	2441.0	-8.95	0.50	10.01	1.56	1.43	20.96	125	19.40
2DH5	2480.0	-8.13	0.50	10.01	2.38	1.73	20.96	125	18.58
3DH5	2402.0	-9.03	0.50	10.01	1.48	1.41	20.96	125	19.48
3DH5	2441.0	-7.98	0.50	10.01	2.53	1.79	20.96	125	18.43
3DH5	2480.0	-8.21	0.50	10.01	2.30	1.70	20.96	125	18.66
Inquiry	2441.0	-9.97	0.50	10.01	0.54	1.13	20.96	125	20.42

Sample Calculation:

Result = Reading + Cable Loss (including the cable(s) customer supplied)+ Attenuator

Test was not performed at AFH mode, because the decrease of number of channel (min: 20ch) at AFH mode does not influence on the output power and bandwidth of the EUT.

As this device had AFH mode and frequency separation could not meet the requirement of over 20dB BW without 2/3 relaxation, 125mW power limit was applied to it.

UL Japan, Inc.

Head Office EMC Lab.

4383-326 Asama-cho, Ise-shi, Mie-ken 516-0021 JAPAN

Telephone : +81 596 24 8999

Facsimile : +81 596 24 8124

Radiated Spurious Emission
(NR-241 (Left handle))

Test place Head Office EMC Lab. No.2 Semi Anechoic Chamber
Report No. 10012781H
Date 05/22/2013
Temperature/ Humidity 23 deg. C / 63% RH
Engineer Hiroshi Kukita
Mode Tx, DH5 2402MHz

Polarity	Frequency [MHz]	Detector	Reading [dBuV]	Ant.Fac. [dB/m]	Loss [dB]	Gain [dB]	Result [dBuV/m]	Limit [dBuV/m]	Margin [dB]	Remark
Hori	30.000	QP	23.0	17.4	6.7	28.6	18.5	40.0	21.5	
Hori	36.300	QP	22.7	15.9	6.8	28.6	16.8	40.0	23.2	
Hori	59.700	QP	23.4	8.0	7.1	28.6	9.9	40.0	30.1	
Hori	111.002	QP	28.4	11.7	7.6	28.3	19.4	43.5	24.1	
Hori	144.307	QP	27.4	14.7	7.8	28.2	21.7	43.5	21.8	
Hori	481.004	QP	25.5	17.9	9.6	28.7	24.3	46.0	21.7	
Hori	2390.000	PK	44.9	26.8	2.6	35.7	38.6	73.9	35.3	
Hori	2558.162	PK	53.5	26.8	2.7	35.6	47.4	73.9	26.5	
Hori	4804.000	PK	43.6	30.6	4.5	34.9	43.8	73.9	30.1	
Hori	7206.000	PK	43.2	35.5	5.1	34.9	48.9	73.9	25.0	
Hori	9608.000	PK	43.6	38.2	6.0	35.4	52.4	73.9	21.5	
Hori	2390.000	AV	32.5	26.8	2.6	35.7	26.2	53.9	27.7	
Hori	2558.162	AV	48.7	26.8	2.7	35.6	42.6	53.9	11.3	
Hori	4804.000	AV	33.6	30.6	4.5	34.9	33.8	53.9	20.1	
Hori	7206.000	AV	31.4	35.5	5.1	34.9	37.1	53.9	16.8	
Hori	9608.000	AV	31.3	38.2	6.0	35.4	40.1	53.9	13.8	
Vert	30.000	QP	28.0	17.4	6.7	28.6	23.5	40.0	16.5	
Vert	37.160	QP	28.2	15.6	6.8	28.6	22.0	40.0	18.0	
Vert	59.990	QP	30.1	8.0	7.1	28.6	16.6	40.0	23.4	
Vert	111.100	QP	23.5	11.7	7.6	28.3	14.5	43.5	29.0	
Vert	144.309	QP	26.6	14.7	7.8	28.2	20.9	43.5	22.6	
Vert	480.832	QP	27.5	17.9	9.6	28.7	26.3	46.0	19.7	
Vert	2390.000	PK	45.4	26.8	2.6	35.7	39.1	73.9	34.8	
Vert	2557.982	PK	49.2	26.8	2.7	35.6	43.1	73.9	30.8	
Vert	4804.000	PK	43.6	30.6	4.5	34.9	43.8	73.9	30.1	
Vert	7206.000	PK	43.3	35.5	5.1	34.9	49.0	73.9	24.9	
Vert	9608.000	PK	43.3	38.2	6.0	35.4	52.1	73.9	21.8	
Vert	2390.000	AV	32.4	26.8	2.6	35.7	26.1	53.9	27.8	
Vert	2557.982	AV	42.9	26.8	2.7	35.6	36.8	53.9	17.1	
Vert	4804.000	AV	32.9	30.6	4.5	34.9	33.1	53.9	20.8	
Vert	7206.000	AV	31.6	35.5	5.1	34.9	37.3	53.9	16.6	
Vert	9608.000	AV	31.8	38.2	6.0	35.4	40.6	53.9	13.3	

Result = Reading + Ant Factor + Loss (Cable+Attenuator+Filter-Distance factor(above 10GHz)) - Gain(Amplifier)

*Other frequency noises omitted in this report were not seen or had enough margin (more than 20dB).

*The 10th harmonic was not seen so the result was its base noise level.

Distance factor: 10GHz-26.5GHz 20log(3.0m/1.0m)= 9.5dB

20dBc Data Sheet

Polarity	Frequency [MHz]	Detector	Reading [dBuV]	Ant Factor [dB/m]	Loss [dB]	Gain [dB]	Result [dBuV/m]	Limit [dBuV/m]	Margin [dB]	Remark
Hori	2402.000	PK	100.0	26.8	2.6	35.7	93.7	-	-	Carrier
Hori	2400.000	PK	54.2	26.8	2.6	35.7	47.9	73.7	25.8	
Vert	2402.000	PK	94.3	26.8	2.6	35.7	88.0	-	-	Carrier
Vert	2400.000	PK	48.7	26.8	2.6	35.7	42.4	68.0	25.6	

Result = Reading + Ant Factor + Loss (Cable+Attenuator+Filter-Distance factor(above 10GHz)) - Gain(Amplifier)

UL Japan, Inc.

Head Office EMC Lab.

4383-326 Asama-cho, Ise-shi, Mie-ken 516-0021 JAPAN

Telephone : +81 596 24 8999

Facsimile : +81 596 24 8124

Radiated Spurious Emission
(NR-241 (Left handle))

Test place Head Office EMC Lab. No.2 Semi Anechoic Chamber
Report No. 10012781H
Date 05/22/2013
Temperature/ Humidity 23 deg. C / 63% RH
Engineer Hiroshi Kukita
Mode Tx, DH5 2441MHz

Polarity	Frequency [MHz]	Detector	Reading [dBuV]	Ant.Fac. [dB/m]	Loss [dB]	Gain [dB]	Result [dBuV/m]	Limit [dBuV/m]	Margin [dB]	Remark
Hori	30.000	QP	23.0	17.4	6.7	28.6	18.5	40.0	21.5	
Hori	36.690	QP	22.8	15.7	6.8	28.6	16.7	40.0	23.3	
Hori	59.990	QP	24.8	8.0	7.1	28.6	11.3	40.0	28.7	
Hori	110.992	QP	27.8	11.7	7.6	28.3	18.8	43.5	24.7	
Hori	146.260	QP	28.0	14.8	7.8	28.2	22.4	43.5	21.1	
Hori	480.985	QP	25.3	17.9	9.6	28.7	24.1	46.0	21.9	
Hori	2597.010	PK	51.9	26.9	2.7	35.6	45.9	73.9	28.0	
Hori	4882.000	PK	44.6	30.9	4.4	34.9	45.0	73.9	28.9	
Hori	7323.000	PK	42.8	35.7	5.2	34.9	48.8	73.9	25.1	
Hori	9764.000	PK	43.6	38.4	6.0	35.4	52.6	73.9	21.3	
Hori	2597.010	AV	47.0	26.9	2.7	35.6	41.0	53.9	12.9	
Hori	4882.000	AV	32.7	30.9	4.4	34.9	33.1	53.9	20.8	
Hori	7323.000	AV	31.6	35.7	5.2	34.9	37.6	53.9	16.3	
Hori	9764.000	AV	31.8	38.4	6.0	35.4	40.8	53.9	13.1	
Vert	30.000	QP	27.6	17.4	6.7	28.6	23.1	40.0	16.9	
Vert	36.690	QP	28.2	15.7	6.8	28.6	22.1	40.0	17.9	
Vert	59.990	QP	29.6	8.0	7.1	28.6	16.1	40.0	23.9	
Vert	111.005	QP	23.5	11.7	7.6	28.3	14.5	43.5	29.0	
Vert	144.214	QP	26.5	14.7	7.8	28.2	20.8	43.5	22.7	
Vert	481.000	QP	27.4	17.9	9.6	28.7	26.2	46.0	19.8	
Vert	2597.011	PK	49.5	26.9	2.7	35.6	43.5	73.9	30.4	
Vert	4882.000	PK	45.4	30.9	4.4	34.9	45.8	73.9	28.1	
Vert	7323.000	PK	43.3	35.7	5.2	34.9	49.3	73.9	24.6	
Vert	9764.000	PK	44.3	38.4	6.0	35.4	53.3	73.9	20.6	
Vert	2597.011	AV	42.4	26.9	2.7	35.6	36.4	53.9	17.5	
Vert	4882.000	AV	34.5	30.9	4.4	34.9	34.9	53.9	19.0	
Vert	7323.000	AV	31.6	35.7	5.2	34.9	37.6	53.9	16.3	
Vert	9764.000	AV	31.8	38.4	6.0	35.4	40.8	53.9	13.1	

Result = Reading + Ant Factor + Loss (Cable+Attenuator+Filter-Distance factor(above 10GHz)) - Gain(Amplifier)

*Other frequency noises omitted in this report were not seen or had enough margin (more than 20dB).

*The 10th harmonic was not seen so the result was its base noise level.

Distance factor: 10GHz-26.5GHz 20log(3.0m/1.0m)= 9.5dB

Radiated Spurious Emission
(NR-241 (Left handle))

Test place : Head Office EMC Lab. No.2 Semi Anechoic Chamber
Report No. : 10012781H
Date : 05/22/2013
Temperature/ Humidity : 23 deg. C / 63% RH
Engineer : Hiroshi Kukita
Mode : Tx, DH5 2480MHz

Polarity	Frequency [MHz]	Detector	Reading [dBuV]	Ant.Fac. [dB/m]	Loss [dB]	Gain [dB]	Result [dBuV/m]	Limit [dBuV/m]	Margin [dB]	Remark
Hori	30.000	QP	23.1	17.4	6.7	28.6	18.6	40.0	21.4	
Hori	36.800	QP	23.0	15.7	6.8	28.6	16.9	40.0	23.1	
Hori	59.980	QP	24.6	8.0	7.1	28.6	11.1	40.0	28.9	
Hori	110.992	QP	27.8	11.7	7.6	28.3	18.8	43.5	24.7	
Hori	146.240	QP	27.9	14.8	7.8	28.2	22.3	43.5	21.2	
Hori	481.006	QP	25.4	17.9	9.6	28.7	24.2	46.0	21.8	
Hori	2483.500	PK	50.1	26.7	2.6	35.7	43.7	73.9	30.2	
Hori	2636.004	PK	48.7	27.0	2.7	35.6	42.8	73.9	31.1	
Hori	4960.000	PK	43.5	31.1	4.4	34.9	44.1	73.9	29.8	
Hori	7440.000	PK	43.5	35.9	5.2	34.9	49.7	73.9	24.2	
Hori	9920.000	PK	43.4	38.7	6.0	35.4	52.7	73.9	21.2	
Hori	2483.500	AV	37.4	26.7	2.6	35.7	31.0	53.9	22.9	
Hori	2636.004	AV	41.6	27.0	2.7	35.6	35.7	53.9	18.2	
Hori	4960.000	AV	32.5	31.1	4.4	34.9	33.1	53.9	20.8	
Hori	7440.000	AV	31.7	35.9	5.2	34.9	37.9	53.9	16.0	
Hori	9920.000	AV	32.2	38.7	6.0	35.4	41.5	53.9	12.4	
Vert	30.000	QP	27.5	17.4	6.7	28.6	23.0	40.0	17.0	
Vert	36.800	QP	28.0	15.7	6.8	28.6	21.9	40.0	18.1	
Vert	59.980	QP	29.4	8.0	7.1	28.6	15.9	40.0	24.1	
Vert	111.005	QP	23.4	11.7	7.6	28.3	14.4	43.5	29.1	
Vert	144.214	QP	26.6	14.7	7.8	28.2	20.9	43.5	22.6	
Vert	481.003	QP	27.4	17.9	9.6	28.7	26.2	46.0	19.8	
Vert	2483.500	PK	46.9	26.7	2.6	35.7	40.5	73.9	33.4	
Vert	2636.004	PK	45.8	27.0	2.7	35.6	39.9	73.9	34.0	
Vert	4960.000	PK	45.0	31.1	4.4	34.9	45.6	73.9	28.3	
Vert	7440.000	PK	43.8	35.9	5.2	34.9	50.0	73.9	23.9	
Vert	9920.000	PK	43.6	38.7	6.0	35.4	52.9	73.9	21.0	
Vert	2483.500	AV	34.4	26.7	2.6	35.7	28.0	53.9	25.9	
Vert	2636.004	AV	37.1	27.0	2.7	35.6	31.2	53.9	22.7	
Vert	4960.000	AV	34.5	31.1	4.4	34.9	35.1	53.9	18.8	
Vert	7440.000	AV	31.8	35.9	5.2	34.9	38.0	53.9	15.9	
Vert	9920.000	AV	32.5	38.7	6.0	35.4	41.8	53.9	12.1	

Result = Reading + Ant Factor + Loss (Cable+Attenuator+Filter-Distance factor(above 10GHz)) - Gain(Amplifier)

*Other frequency noises omitted in this report were not seen or had enough margin (more than 20dB).

*The 10th harmonic was not seen so the result was its base noise level.

Distance factor: 10GHz-26.5GHz 20log(3.0m/1.0m)= 9.5dB

Radiated Spurious Emission
(NR-241 (Left handle))

Test place : Head Office EMC Lab. No.2 Semi Anechoic Chamber
Report No. : 10012781H
Date : 05/22/2013
Temperature/ Humidity : 23 deg. C / 63% RH
Engineer : Hiroshi Kukita
Mode : Tx, 3DH5 2402MHz

Polarity	Frequency [MHz]	Detector	Reading [dBuV]	Ant.Fac. [dB/m]	Loss [dB]	Gain [dB]	Result [dBuV/m]	Limit [dBuV/m]	Margin [dB]	Remark
Hori	30.000	QP	22.9	17.4	6.7	28.6	18.4	40.0	21.6	
Hori	37.000	QP	23.7	15.6	6.8	28.6	17.5	40.0	22.5	
Hori	60.000	QP	23.6	8.0	7.1	28.6	10.1	40.0	29.9	
Hori	111.002	QP	28.5	11.7	7.6	28.3	19.5	43.5	24.0	
Hori	146.586	QP	28.6	14.8	7.8	28.2	23.0	43.5	20.5	
Hori	480.999	QP	25.7	17.9	9.6	28.7	24.5	46.0	21.5	
Hori	2390.000	PK	44.5	26.8	2.6	35.7	38.2	73.9	35.7	
Hori	2558.016	PK	53.6	26.8	2.7	35.6	47.5	73.9	26.4	
Hori	4804.000	PK	45.0	30.6	4.5	34.9	45.2	73.9	28.7	
Hori	7206.000	PK	43.4	35.5	5.1	34.9	49.1	73.9	24.8	
Hori	9608.000	PK	43.4	38.2	6.0	35.4	52.2	73.9	21.7	
Hori	2390.000	AV	34.0	26.8	2.6	35.7	27.7	53.9	26.2	
Hori	2558.016	AV	47.0	26.8	2.7	35.6	40.9	53.9	13.0	
Hori	4804.000	AV	32.5	30.6	4.5	34.9	32.7	53.9	21.2	
Hori	7206.000	AV	31.2	35.5	5.1	34.9	36.9	53.9	17.0	
Hori	9608.000	AV	31.3	38.2	6.0	35.4	40.1	53.9	13.8	
Vert	30.000	QP	26.9	17.4	6.7	28.6	22.4	40.0	17.6	
Vert	37.000	QP	27.6	15.6	6.8	28.6	21.4	40.0	18.6	
Vert	60.000	QP	29.8	8.0	7.1	28.6	16.3	40.0	23.7	
Vert	111.000	QP	24.9	11.7	7.6	28.3	15.9	43.5	27.6	
Vert	146.009	QP	27.7	14.8	7.8	28.2	22.1	43.5	21.4	
Vert	480.620	QP	27.4	17.9	9.6	28.7	26.2	46.0	19.8	
Vert	2390.000	PK	44.8	26.8	2.6	35.7	38.5	73.9	35.4	
Vert	2558.026	PK	49.4	26.8	2.7	35.6	43.3	73.9	30.6	
Vert	4804.000	PK	44.4	30.6	4.5	34.9	44.6	73.9	29.3	
Vert	7206.000	PK	43.4	35.5	5.1	34.9	49.1	73.9	24.8	
Vert	9608.000	PK	42.0	38.2	6.0	35.4	50.8	73.9	23.1	
Vert	2390.000	AV	32.3	26.8	2.6	35.7	26.0	53.9	27.9	
Vert	2558.026	AV	41.4	26.8	2.7	35.6	35.3	53.9	18.6	
Vert	4804.000	AV	32.7	30.6	4.5	34.9	32.9	53.9	21.0	
Vert	7206.000	AV	31.0	35.5	5.1	34.9	36.7	53.9	17.2	
Vert	9608.000	AV	31.3	38.2	6.0	35.4	40.1	53.9	13.8	

Result = Reading + Ant Factor + Loss (Cable+Attenuator+Filter-Distance factor(above 10GHz)) - Gain(Amplifier)

*Other frequency noises omitted in this report were not seen or had enough margin (more than 20dB).

*The 10th harmonic was not seen so the result was its base noise level.
Distance factor: 10GHz-26.5GHz 20log(3.0m/1.0m)= 9.5dB

20dBc Data Sheet

Polarity	Frequency [MHz]	Detector	Reading [dBuV]	Ant Factor [dB/m]	Loss [dB]	Gain [dB]	Result [dBuV/m]	Limit [dBuV/m]	Margin [dB]	Remark
Hori	2402.000	PK	99.6	26.8	2.6	35.7	93.3	-	-	Carrier
Hori	2400.000	PK	50.1	26.8	2.6	35.7	43.8	73.3	29.5	
Vert	2402.000	PK	95.6	26.8	2.6	35.7	89.3	-	-	Carrier
Vert	2400.000	PK	46.0	26.8	2.6	35.7	39.7	69.3	29.6	

Result = Reading + Ant Factor + Loss (Cable+Attenuator+Filter-Distance factor(above 10GHz)) - Gain(Amplifier)

Radiated Spurious Emission
(NR-241 (Left handle))

Test place Head Office EMC Lab. No.2 Semi Anechoic Chamber
Report No. 10012781H
Date 05/22/2013
Temperature/ Humidity 23 deg. C / 63% RH
Engineer Hiroshi Kukita
Mode Tx, 3DH5 2441MHz

Polarity	Frequency [MHz]	Detector	Reading [dBuV]	Ant.Fac. [dB/m]	Loss [dB]	Gain [dB]	Result [dBuV/m]	Limit [dBuV/m]	Margin [dB]	Remark
Hori	30.000	QP	23.0	17.4	6.7	28.6	18.5	40.0	21.5	
Hori	37.800	QP	22.9	15.3	6.8	28.6	16.4	40.0	23.6	
Hori	59.970	QP	23.9	8.0	7.1	28.6	10.4	40.0	29.6	
Hori	110.992	QP	27.8	11.7	7.6	28.3	18.8	43.5	24.7	
Hori	146.440	QP	27.6	14.8	7.8	28.2	22.0	43.5	21.5	
Hori	481.000	QP	25.4	17.9	9.6	28.7	24.2	46.0	21.8	
Hori	2597.010	PK	52.9	26.9	2.7	35.6	46.9	73.9	27.0	
Hori	4882.000	PK	44.0	30.9	4.4	34.9	44.4	73.9	29.5	
Hori	7323.000	PK	43.5	35.7	5.2	34.9	49.5	73.9	24.4	
Hori	9764.000	PK	44.3	38.4	6.0	35.4	53.3	73.9	20.6	
Hori	2597.010	AV	45.9	26.9	2.7	35.6	39.9	53.9	14.0	
Hori	4882.000	AV	32.4	30.9	4.4	34.9	32.8	53.9	21.1	
Hori	7323.000	AV	31.7	35.7	5.2	34.9	37.7	53.9	16.2	
Hori	9764.000	AV	31.8	38.4	6.0	35.4	40.8	53.9	13.1	
Vert	30.000	QP	27.2	17.4	6.7	28.6	22.7	40.0	17.3	
Vert	37.800	QP	27.5	15.3	6.8	28.6	21.0	40.0	19.0	
Vert	59.970	QP	29.6	8.0	7.1	28.6	16.1	40.0	23.9	
Vert	111.000	QP	23.2	11.7	7.6	28.3	14.2	43.5	29.3	
Vert	146.524	QP	26.3	14.8	7.8	28.2	20.7	43.5	22.8	
Vert	480.994	QP	27.2	17.9	9.6	28.7	26.0	46.0	20.0	
Vert	2597.000	PK	49.2	26.9	2.7	35.6	43.2	73.9	30.7	
Vert	4882.000	PK	45.6	30.9	4.4	34.9	46.0	73.9	28.0	
Vert	7323.000	PK	44.1	35.7	5.2	34.9	50.1	73.9	23.8	
Vert	9764.000	PK	44.6	38.4	6.0	35.4	53.6	73.9	20.4	
Vert	2597.000	AV	41.9	26.9	2.7	35.6	35.9	53.9	18.0	
Vert	4882.000	AV	33.4	30.9	4.4	34.9	33.8	53.9	20.1	
Vert	7323.000	AV	31.7	35.7	5.2	34.9	37.7	53.9	16.2	
Vert	9764.000	AV	31.8	38.4	6.0	35.4	40.8	53.9	13.1	

Result = Reading + Ant Factor + Loss (Cable+Attenuator+Filter-Distance factor(above 10GHz)) - Gain(Amplifier)

*Other frequency noises omitted in this report were not seen or had enough margin (more than 20dB).

*The 10th harmonic was not seen so the result was its base noise level.

Distance factor: 10GHz-26.5GHz $20\log(3.0\text{m}/1.0\text{m})= 9.5\text{dB}$

UL Japan, Inc.

Head Office EMC Lab.

4383-326 Asama-cho, Ise-shi, Mie-ken 516-0021 JAPAN

Telephone : +81 596 24 8999

Facsimile : +81 596 24 8124

Radiated Spurious Emission
(NR-241 (Left handle))

Test place Head Office EMC Lab. No.2 Semi Anechoic Chamber
Report No. 10012781H
Date 05/22/2013
Temperature/ Humidity 23 deg. C / 63% RH
Engineer Hiroshi Kukita
Mode Tx, 3DH5 2480MHz

Polarity	Frequency [MHz]	Detector	Reading [dBuV]	Ant.Fac. [dB/m]	Loss [dB]	Gain [dB]	Result [dBuV/m]	Limit [dBuV/m]	Margin [dB]	Remark
Hori	30.000	QP	23.3	17.4	6.7	28.6	18.8	40.0	21.2	
Hori	36.800	QP	23.0	15.7	6.8	28.6	16.9	40.0	23.1	
Hori	59.990	QP	23.6	8.0	7.1	28.6	10.1	40.0	29.9	
Hori	111.000	QP	27.9	11.7	7.6	28.3	18.9	43.5	24.6	
Hori	144.440	QP	27.4	14.7	7.8	28.2	21.7	43.5	21.8	
Hori	480.980	QP	25.4	17.9	9.6	28.7	24.2	46.0	21.8	
Hori	2483.500	PK	52.5	26.7	2.6	35.7	46.1	73.9	27.8	
Hori	2635.965	PK	49.2	27.0	2.7	35.6	43.3	73.9	30.6	
Hori	4960.000	PK	43.0	31.1	4.4	34.9	43.6	73.9	30.3	
Hori	7440.000	PK	43.6	35.9	5.2	34.9	49.8	73.9	24.1	
Hori	9920.000	PK	44.3	38.7	6.0	35.4	53.6	73.9	20.3	
Hori	2483.500	AV	38.5	26.7	2.6	35.7	32.1	53.9	21.8	
Hori	2635.965	AV	40.4	27.0	2.7	35.6	34.5	53.9	19.4	
Hori	4960.000	AV	32.1	31.1	4.4	34.9	32.7	53.9	21.2	
Hori	7440.000	AV	31.8	35.9	5.2	34.9	38.0	53.9	15.9	
Hori	9920.000	AV	32.4	38.7	6.0	35.4	41.7	53.9	12.2	
Vert	30.000	QP	27.0	17.4	6.7	28.6	22.5	40.0	17.5	
Vert	36.800	QP	27.4	15.7	6.8	28.6	21.3	40.0	18.7	
Vert	59.990	QP	29.6	8.0	7.1	28.6	16.1	40.0	23.9	
Vert	111.001	QP	23.4	11.7	7.6	28.3	14.4	43.5	29.1	
Vert	146.533	QP	26.6	14.8	7.8	28.2	21.0	43.5	22.5	
Vert	481.000	QP	27.5	17.9	9.6	28.7	26.3	46.0	19.7	
Vert	2483.500	PK	48.5	26.7	2.6	35.7	42.1	73.9	31.8	
Vert	2635.975	PK	46.2	27.0	2.7	35.6	40.3	73.9	33.6	
Vert	4960.000	PK	44.1	31.1	4.4	34.9	44.7	73.9	29.2	
Vert	7440.000	PK	43.2	35.9	5.2	34.9	49.4	73.9	24.5	
Vert	9920.000	PK	44.2	38.7	6.0	35.4	53.5	73.9	20.4	
Vert	2483.500	AV	36.9	26.7	2.6	35.7	30.5	53.9	23.4	
Vert	2635.975	AV	36.4	27.0	2.7	35.6	30.5	53.9	23.4	
Vert	4960.000	AV	33.6	31.1	4.4	34.9	34.2	53.9	19.7	
Vert	7440.000	AV	31.7	35.9	5.2	34.9	37.9	53.9	16.0	
Vert	9920.000	AV	32.4	38.7	6.0	35.4	41.7	53.9	12.2	

Result = Reading + Ant Factor + Loss (Cable+Attenuator+Filter-Distance factor(above 10GHz)) - Gain(Amplifier)

*Other frequency noises omitted in this report were not seen or had enough margin (more than 20dB).

*The 10th harmonic was not seen so the result was its base noise level.

Distance factor: 10GHz-26.5GHz 20log(3.0m/1.0m)= 9.5dB

Radiated Spurious Emission
(NR-241 (Right handle))

Test place Head Office EMC Lab. No.2 Semi Anechoic Chamber
Report No. 10012781H
Date 05/24/2013 05/26/2013
Temperature/ Humidity 20 deg. C / 46% RH 24 deg. C / 64% RH
Engineer Kazuya Yoshioka Shinya Watanabe
(Below 1GHz) (Above 1GHz)
Mode Tx, DH5 2402MHz

Polarity	Frequency [MHz]	Detector	Reading [dBuV]	Ant.Fac. [dB/m]	Loss [dB]	Gain [dB]	Result [dBuV/m]	Limit [dBuV/m]	Margin [dB]	Remark
Hori	36.178	QP	22.7	15.9	6.8	28.6	16.8	40.0	23.2	
Hori	44.444	QP	22.8	12.6	6.9	28.6	13.7	40.0	26.3	
Hori	110.985	QP	28.0	11.7	7.6	28.3	19.0	43.5	24.5	
Hori	200.121	QP	21.8	16.6	8.1	27.8	18.7	43.5	24.8	
Hori	400.121	QP	23.1	17.4	9.3	28.4	21.4	46.0	24.6	
Hori	500.021	QP	23.0	18.0	9.8	28.8	22.0	46.0	24.0	
Hori	2390.000	PK	44.7	26.8	2.4	35.7	38.2	73.9	35.7	
Hori	2558.000	PK	51.2	26.8	2.4	35.6	44.8	73.9	29.1	
Hori	2822.300	PK	53.7	27.3	2.6	35.4	48.2	73.9	25.7	
Hori	4804.000	PK	43.6	30.6	4.2	34.9	43.5	73.9	30.4	
Hori	7206.000	PK	43.2	35.5	4.3	34.9	48.1	73.9	25.8	
Hori	9608.000	PK	43.6	38.2	5.0	35.4	51.4	73.9	22.5	
Hori	2390.000	AV	33.1	26.8	2.4	35.7	26.6	53.9	27.3	
Hori	2558.000	AV	46.5	26.8	2.4	35.6	40.1	53.9	13.8	
Hori	2822.300	AV	50.9	27.3	2.6	35.4	45.4	53.9	8.5	
Hori	4804.000	AV	32.2	30.6	3.4	34.9	31.3	53.9	22.6	
Hori	7206.000	AV	32.0	35.5	4.3	34.9	36.9	53.9	17.0	
Hori	9608.000	AV	31.8	38.2	5.0	35.4	39.6	53.9	14.3	
Vert	36.173	QP	26.8	15.9	6.8	28.6	20.9	40.0	19.1	
Vert	44.432	QP	27.1	12.6	6.9	28.6	18.0	40.0	22.0	
Vert	110.999	QP	30.0	11.7	7.6	28.3	21.0	43.5	22.5	
Vert	200.131	QP	21.8	16.6	8.1	27.8	18.7	43.5	24.8	
Vert	400.022	QP	23.1	17.4	9.3	28.4	21.4	46.0	24.6	
Vert	500.023	QP	23.0	18.0	9.8	28.8	22.0	46.0	24.0	
Vert	2390.000	PK	44.2	26.8	2.4	35.7	37.7	73.9	36.2	
Vert	2558.000	PK	48.8	26.8	2.4	35.6	42.4	73.9	31.5	
Vert	2822.300	PK	49.3	27.3	2.6	35.4	43.8	73.9	30.1	
Vert	4804.000	PK	43.6	30.6	4.2	34.9	43.5	73.9	30.4	
Vert	7206.000	PK	43.3	35.5	4.3	34.9	48.2	73.9	25.7	
Vert	9608.000	PK	43.2	38.2	5.0	35.4	51.0	73.9	22.9	
Vert	2390.000	AV	32.6	26.8	2.4	35.7	26.1	53.9	27.8	
Vert	2558.000	AV	43.3	26.8	2.4	35.6	36.9	53.9	17.0	
Vert	2822.300	AV	44.1	27.3	2.6	35.4	38.6	53.9	15.3	
Vert	4804.000	AV	32.4	30.6	3.4	34.9	31.5	53.9	22.4	
Vert	7206.000	AV	32.0	35.5	4.3	34.9	36.9	53.9	17.0	
Vert	9608.000	AV	32.2	38.2	5.0	35.4	40.0	53.9	13.9	

Result = Reading + Ant Factor + Loss (Cable+Attenuator+Filter-Distance factor(above 10GHz)) - Gain(Amplifier)

*Other frequency noises omitted in this report were not seen or had enough margin (more than 20dB).

*The 10th harmonic was not seen so the result was its base noise level.

Distance factor: 10GHz-26.5GHz 20log(3.0m/1.0m)= 9.5dB

20dBc Data Sheet

Polarity	Frequency [MHz]	Detector	Reading [dBuV]	Ant Factor [dB/m]	Loss [dB]	Gain [dB]	Result [dBuV/m]	Limit [dBuV/m]	Margin [dB]	Remark
Hori	2402.000	PK	98.9	26.8	2.4	35.7	92.4	-	-	Carrier
Hori	2400.000	PK	53.5	26.8	2.4	35.7	47.0	72.4	25.4	
Vert	2402.000	PK	96.3	26.8	2.4	35.7	89.8	-	-	Carrier
Vert	2400.000	PK	51.1	26.8	2.4	35.7	44.6	69.8	25.2	

Result = Reading + Ant Factor + Loss (Cable+Attenuator+Filter-Distance factor(above 10GHz)) - Gain(Amplifier)

UL Japan, Inc.

Head Office EMC Lab.

4383-326 Asama-cho, Ise-shi, Mie-ken 516-0021 JAPAN

Telephone : +81 596 24 8999

Facsimile : +81 596 24 8124

Radiated Spurious Emission
(NR-241 (Right handle))

Test place Head Office EMC Lab. No.2 Semi Anechoic Chamber
Report No. 10012781H
Date 05/24/2013 05/26/2013
Temperature/ Humidity 20 deg. C / 46% RH 24 deg. C / 64% RH
Engineer Kazuya Yoshioka Shinya Watanabe
(Below 1GHz) (Above 1GHz)
Mode Tx, DH5 2441MHz

Polarity	Frequency [MHz]	Detector	Reading [dBuV]	Ant.Fac. [dB/m]	Loss [dB]	Gain [dB]	Result [dBuV/m]	Limit [dBuV/m]	Margin [dB]	Remark
Hori	36.128	QP	22.7	16.0	6.8	28.6	16.9	40.0	23.1	
Hori	44.212	QP	22.8	12.7	6.9	28.6	13.8	40.0	26.2	
Hori	111.013	QP	27.6	11.7	7.6	28.3	18.6	43.5	24.9	
Hori	200.112	QP	21.8	16.6	8.1	27.8	18.7	43.5	24.8	
Hori	400.019	QP	23.1	17.4	9.3	28.4	21.4	46.0	24.6	
Hori	500.091	QP	23.0	18.0	9.8	28.8	22.0	46.0	24.0	
Hori	2822.300	PK	53.6	27.3	2.6	35.4	48.1	73.9	25.8	
Hori	4882.000	PK	46.3	30.9	4.2	34.9	46.5	73.9	27.4	
Hori	7323.000	PK	43.3	35.7	4.3	34.9	48.4	73.9	25.5	
Hori	9764.000	PK	43.4	38.4	5.0	35.4	51.4	73.9	22.5	
Hori	2822.300	AV	50.8	27.3	2.6	35.4	45.3	53.9	8.6	
Hori	4882.000	AV	32.3	30.9	3.5	34.9	31.8	53.9	22.1	
Hori	7323.000	AV	32.1	35.7	4.3	34.9	37.2	53.9	16.7	
Hori	9764.000	AV	32.0	38.4	5.0	35.4	40.0	53.9	13.9	
Vert	36.113	QP	25.8	16.0	6.8	28.6	20.0	40.0	20.0	
Vert	44.552	QP	27.5	12.6	6.9	28.6	18.4	40.0	21.6	
Vert	110.999	QP	28.7	11.7	7.6	28.3	19.7	43.5	23.8	
Vert	200.012	QP	21.8	16.6	8.1	27.8	18.7	43.5	24.8	
Vert	400.012	QP	23.1	17.4	9.3	28.4	21.4	46.0	24.6	
Vert	500.121	QP	23.0	18.0	9.8	28.8	22.0	46.0	24.0	
Vert	2822.300	PK	50.1	27.3	2.6	35.4	44.6	73.9	29.3	
Vert	4882.000	PK	46.3	30.9	4.2	34.9	46.5	73.9	27.4	
Vert	7323.000	PK	44.0	35.7	4.3	34.9	49.1	73.9	24.8	
Vert	9764.000	PK	43.5	38.4	5.0	35.4	51.5	73.9	22.4	
Vert	2822.300	AV	48.8	27.3	2.6	35.4	43.3	53.9	10.6	
Vert	4882.000	AV	32.4	30.9	3.5	34.9	31.9	53.9	22.0	
Vert	7323.000	AV	32.3	35.7	4.3	34.9	37.4	53.9	16.5	
Vert	9764.000	AV	31.8	38.4	5.0	35.4	39.8	53.9	14.1	

Result = Reading + Ant Factor + Loss (Cable+Attenuator+Filter-Distance factor(above 10GHz)) - Gain(Amplifier)

*Other frequency noises omitted in this report were not seen or had enough margin (more than 20dB).

*The 10th harmonic was not seen so the result was its base noise level.

Distance factor: 10GHz-26.5GHz 20log(3.0m/1.0m)= 9.5dB

Radiated Spurious Emission
(NR-241 (Right handle))

Test place Head Office EMC Lab. No.2 Semi Anechoic Chamber
Report No. 10012781H
Date 05/24/2013 05/26/2013
Temperature/ Humidity 20 deg. C / 46% RH 24 deg. C / 64% RH
Engineer Kazuya Yoshioka Shinya Watanabe
(Below 1GHz) (Above 1GHz)
Mode Tx, DH5 2480MHz

Polarity	Frequency [MHz]	Detector	Reading [dBuV]	Ant.Fac. [dB/m]	Loss [dB]	Gain [dB]	Result [dBuV/m]	Limit [dBuV/m]	Margin [dB]	Remark
Hori	36.123	QP	22.7	16.0	6.8	28.6	16.9	40.0	23.1	
Hori	44.111	QP	22.8	12.8	6.9	28.6	13.9	40.0	26.1	
Hori	110.993	QP	28.2	11.7	7.6	28.3	19.2	43.5	24.3	
Hori	200.098	QP	21.8	16.6	8.1	27.8	18.7	43.5	24.8	
Hori	400.023	QP	23.1	17.4	9.3	28.4	21.4	46.0	24.6	
Hori	500.091	QP	23.0	18.0	9.8	28.8	22.0	46.0	24.0	
Hori	2483.500	PK	48.4	26.7	2.4	35.7	41.8	73.9	32.1	
Hori	2822.300	PK	52.3	27.3	2.6	35.4	46.8	73.9	27.1	
Hori	4960.000	PK	44.0	31.1	4.2	34.9	44.4	73.9	29.5	
Hori	7440.000	PK	42.8	35.9	4.4	34.9	48.2	73.9	25.7	
Hori	9920.000	PK	43.5	38.7	5.1	35.4	51.9	73.9	22.0	
Hori	2483.500	AV	35.9	26.7	2.4	35.7	29.3	53.9	24.6	
Hori	2822.300	AV	50.0	27.3	2.6	35.4	44.5	53.9	9.4	
Hori	4960.000	AV	32.3	31.1	3.5	34.9	32.0	53.9	21.9	
Hori	7440.000	AV	32.4	35.9	4.4	34.9	37.8	53.9	16.1	
Hori	9920.000	AV	31.8	38.7	5.1	35.4	40.2	53.9	13.7	
Vert	36.943	QP	26.1	15.6	6.8	28.6	19.9	40.0	20.1	
Vert	44.702	QP	26.9	12.5	6.9	28.6	17.7	40.0	22.3	
Vert	111.007	QP	30.0	11.7	7.6	28.3	21.0	43.5	22.5	
Vert	200.054	QP	21.8	16.6	8.1	27.8	18.7	43.5	24.8	
Vert	400.013	QP	23.1	17.4	9.3	28.4	21.4	46.0	24.6	
Vert	500.131	QP	23.0	18.0	9.8	28.8	22.0	46.0	24.0	
Vert	2483.500	PK	46.0	26.7	2.4	35.7	39.4	73.9	34.5	
Vert	2822.300	PK	51.9	27.3	2.6	35.4	46.4	73.9	27.5	
Vert	4960.000	PK	44.0	31.1	4.2	34.9	44.4	73.9	29.5	
Vert	7440.000	PK	43.4	35.9	4.4	34.9	48.8	73.9	25.1	
Vert	9920.000	PK	43.0	38.7	5.1	35.4	51.4	73.9	22.5	
Vert	2483.500	AV	36.2	26.7	2.4	35.7	29.6	53.9	24.3	
Vert	2822.300	AV	48.1	27.3	2.6	35.4	42.6	53.9	11.3	
Vert	4960.000	AV	32.1	31.1	3.5	34.9	31.8	53.9	22.1	
Vert	7440.000	AV	31.8	35.9	4.4	34.9	37.2	53.9	16.7	
Vert	9920.000	AV	32.0	38.7	5.1	35.4	40.4	53.9	13.5	

Result = Reading + Ant Factor + Loss (Cable+Attenuator+Filter-Distance factor(above 10GHz)) - Gain(Amplifier)

*Other frequency noises omitted in this report were not seen or had enough margin (more than 20dB).

*The 10th harmonic was not seen so the result was its base noise level.

Distance factor: 10GHz-26.5GHz 20log(3.0m/1.0m)= 9.5dB

Radiated Spurious Emission
(NR-243UH (Internal Amplifier))

Test place Head Office EMC Lab. No.4 Semi Anechoic Chamber
Report No. 10012781H
Date 05/31/2013 06/01/2013
Temperature/ Humidity 22 deg. C / 59% RH 24 deg. C / 61% RH
Engineer Hiroshi Kukita Hironobu Ohnishi
(Above 1GHz) (Below 1GHz)
Mode Tx, DH5 2402MHz

Polarity	Frequency [MHz]	Detector	Reading [dBuV]	Ant.Fac. [dB/m]	Loss [dB]	Gain [dB]	Result [dBuV/m]	Limit [dBuV/m]	Margin [dB]	Remark
Hori	42.000	QP	23.0	14.0	7.3	32.2	12.1	40.0	27.9	
Hori	96.200	QP	26.9	9.7	8.0	32.1	12.5	43.5	31.0	
Hori	111.000	QP	30.3	12.2	8.2	32.1	18.6	43.5	24.9	
Hori	150.796	QP	30.6	15.1	8.6	32.1	22.2	43.5	21.3	
Hori	406.998	QP	26.9	17.9	10.5	32.0	23.3	46.0	22.7	
Hori	610.000	QP	22.0	20.2	11.6	32.1	21.7	46.0	24.3	
Hori	2390.000	PK	43.0	27.5	2.6	32.4	40.7	73.9	33.2	
Hori	2557.999	PK	52.1	27.6	2.7	32.3	50.1	73.9	23.8	
Hori	4804.000	PK	41.2	31.3	4.4	31.6	45.3	73.9	28.6	
Hori	7206.000	PK	44.0	35.8	5.2	32.7	52.3	73.9	21.6	
Hori	9608.000	PK	43.6	38.3	6.1	33.3	54.7	73.9	19.2	
Hori	2390.000	AV	34.5	27.5	2.6	32.4	32.2	53.9	21.7	
Hori	2557.999	AV	45.0	27.6	2.7	32.3	43.0	53.9	10.9	
Hori	4804.000	AV	30.0	31.3	4.4	31.6	34.1	53.9	19.8	
Hori	7206.000	AV	30.9	35.8	5.2	32.7	39.2	53.9	14.7	
Hori	9608.000	AV	31.8	38.3	6.1	33.3	42.9	53.9	11.0	
Vert	42.000	QP	22.8	14.0	7.3	32.2	11.9	40.0	28.1	
Vert	96.200	QP	29.8	9.7	8.0	32.1	15.4	43.5	28.1	
Vert	111.000	QP	29.9	12.2	8.2	32.1	18.2	43.5	25.3	
Vert	150.796	QP	35.5	15.1	8.6	32.1	27.1	43.5	16.4	
Vert	406.998	QP	28.3	17.9	10.5	32.0	24.7	46.0	21.3	
Vert	610.000	QP	22.0	20.2	11.6	32.1	21.7	46.0	24.3	
Vert	2390.000	PK	41.2	27.5	2.6	32.4	38.9	73.9	35.0	
Vert	2558.010	PK	49.8	27.6	2.7	32.3	47.8	73.9	26.1	
Vert	4804.000	PK	43.0	31.3	4.4	31.6	47.1	73.9	26.8	
Vert	7206.000	PK	43.8	35.8	5.2	32.7	52.1	73.9	21.8	
Vert	9608.000	PK	43.7	38.3	6.1	33.3	54.8	73.9	19.1	
Vert	2390.000	AV	34.6	27.5	2.6	32.4	32.3	53.9	21.6	
Vert	2558.010	AV	42.0	27.6	2.7	32.3	40.0	53.9	13.9	
Vert	4804.000	AV	32.0	31.3	4.4	31.6	36.1	53.9	17.8	
Vert	7206.000	AV	30.9	35.8	5.2	32.7	39.2	53.9	14.7	
Vert	9608.000	AV	31.9	38.3	6.1	33.3	43.0	53.9	10.9	

Result = Reading + Ant Factor + Loss (Cable+Attenuator+Filter-Distance factor(above 10GHz)) - Gain(Amplifier)

*Other frequency noises omitted in this report were not seen or had enough margin (more than 20dB).

*The 10th harmonic was not seen so the result was its base noise level.

Distance factor: 10GHz-26.5GHz 20log(3.0m/1.0m)= 9.5dB

20dBc Data Sheet

Polarity	Frequency [MHz]	Detector	Reading [dBuV]	Ant Factor [dB/m]	Loss [dB]	Gain [dB]	Result [dBuV/m]	Limit [dBuV/m]	Margin [dB]	Remark
Hori	2402.000	PK	96.7	27.5	2.6	32.4	94.4	-	-	Carrier
Hori	2400.000	PK	51.0	27.5	2.6	32.4	48.7	74.4	25.7	
Vert	2402.000	PK	94.2	27.5	2.6	32.4	91.9	-	-	Carrier
Vert	2400.000	PK	49.4	27.5	2.6	32.4	47.1	71.9	24.8	

Result = Reading + Ant Factor + Loss (Cable+Attenuator+Filter-Distance factor(above 10GHz)) - Gain(Amplifier)

Radiated Spurious Emission
(NR-243UH (Internal Amplifier))

Test place Head Office EMC Lab. No.4 Semi Anechoic Chamber
Report No. 10012781H
Date 05/31/2013 06/01/2013
Temperature/ Humidity 22 deg. C / 59% RH 24 deg. C / 61% RH
Engineer Hiroshi Kukita Hironobu Ohnishi
(Above 1GHz) (Below 1GHz)
Mode Tx, DH5 2441MHz

Polarity	Frequency [MHz]	Detector	Reading [dBuV]	Ant.Fac. [dB/m]	Loss [dB]	Gain [dB]	Result [dBuV/m]	Limit [dBuV/m]	Margin [dB]	Remark
Hori	42.000	QP	22.9	14.0	7.3	32.2	12.0	40.0	28.0	
Hori	96.200	QP	26.8	9.7	8.0	32.1	12.4	43.5	31.1	
Hori	111.000	QP	30.4	12.2	8.2	32.1	18.7	43.5	24.8	
Hori	150.768	QP	30.3	15.1	8.6	32.1	21.9	43.5	21.6	
Hori	406.998	QP	26.8	17.9	10.5	32.0	23.2	46.0	22.8	
Hori	610.000	QP	22.0	20.2	11.6	32.1	21.7	46.0	24.3	
Hori	2596.000	PK	46.2	27.7	2.7	32.3	44.3	73.9	29.6	
Hori	4882.000	PK	43.0	31.5	4.4	31.6	47.3	73.9	26.6	
Hori	7323.000	PK	42.2	35.8	5.3	32.7	50.6	73.9	23.3	
Hori	9764.000	PK	43.4	38.4	6.1	33.4	54.5	73.9	19.4	
Hori	2596.000	AV	37.6	27.7	2.7	32.3	35.7	53.9	18.2	
Hori	4882.000	AV	32.0	31.5	4.4	31.6	36.3	53.9	17.6	
Hori	7323.000	AV	30.8	35.8	5.3	32.7	39.2	53.9	14.7	
Hori	9764.000	AV	31.6	38.4	6.1	33.4	42.7	53.9	11.2	
Vert	42.000	QP	23.1	14.0	7.3	32.2	12.2	40.0	27.8	
Vert	96.200	QP	29.8	9.7	8.0	32.1	15.4	43.5	28.1	
Vert	111.000	QP	30.0	12.2	8.2	32.1	18.3	43.5	25.2	
Vert	150.768	QP	35.5	15.1	8.6	32.1	27.1	43.5	16.4	
Vert	406.998	QP	28.4	17.9	10.5	32.0	24.8	46.0	21.2	
Vert	610.000	QP	22.0	20.2	11.6	32.1	21.7	46.0	24.3	
Vert	2597.022	PK	44.8	27.7	2.7	32.3	42.9	73.9	31.0	
Vert	4882.000	PK	42.0	31.5	4.4	31.6	46.3	73.9	27.6	
Vert	7323.000	PK	43.3	35.8	5.3	32.7	51.7	73.9	22.2	
Vert	9764.000	PK	43.7	38.4	6.1	33.4	54.8	73.9	19.1	
Vert	2597.022	AV	36.4	27.7	2.7	32.3	34.5	53.9	19.4	
Vert	4882.000	AV	31.2	31.5	4.4	31.6	35.5	53.9	18.4	
Vert	7323.000	AV	30.9	35.8	5.3	32.7	39.3	53.9	14.6	
Vert	9764.000	AV	31.6	38.4	6.1	33.4	42.7	53.9	11.2	

Result = Reading + Ant Factor + Loss (Cable+Attenuator+Filter-Distance factor(above 10GHz)) - Gain(Amplifier)

*Other frequency noises omitted in this report were not seen or had enough margin (more than 20dB).

*The 10th harmonic was not seen so the result was its base noise level.

Distance factor: 10GHz-26.5GHz 20log(3.0m/1.0m)= 9.5dB

UL Japan, Inc.

Head Office EMC Lab.

4383-326 Asama-cho, Ise-shi, Mie-ken 516-0021 JAPAN

Telephone : +81 596 24 8999

Facsimile : +81 596 24 8124

Radiated Spurious Emission
(NR-243UH (Internal Amplifier))

Test place Head Office EMC Lab. No.4 Semi Anechoic Chamber
Report No. 10012781H
Date 05/31/2013 06/01/2013
Temperature/ Humidity 22 deg. C / 59% RH 24 deg. C / 61% RH
Engineer Hiroshi Kukita Hironobu Ohnishi
(Above 1GHz) (Below 1GHz)
Mode Tx, DH5 2480MHz

Polarity	Frequency [MHz]	Detector	Reading [dBuV]	Ant.Fac. [dB/m]	Loss [dB]	Gain [dB]	Result [dBuV/m]	Limit [dBuV/m]	Margin [dB]	Remark
Hori	42.000	QP	23.0	14.0	7.3	32.2	12.1	40.0	27.9	
Hori	96.200	QP	26.7	9.7	8.0	32.1	12.3	43.5	31.2	
Hori	111.000	QP	30.6	12.2	8.2	32.1	18.9	43.5	24.6	
Hori	150.790	QP	30.3	15.1	8.6	32.1	21.9	43.5	21.6	
Hori	406.998	QP	26.8	17.9	10.5	32.0	23.2	46.0	22.8	
Hori	610.000	QP	22.1	20.2	11.6	32.1	21.8	46.0	24.2	
Hori	2483.500	PK	46.0	27.5	2.6	32.4	43.7	73.9	30.2	
Hori	3377.746	PK	43.0	28.9	3.1	32.0	43.0	73.9	30.9	
Hori	4960.000	PK	42.6	31.8	4.4	31.6	47.2	73.9	26.7	
Hori	7440.000	PK	42.0	35.9	5.3	32.8	50.4	73.9	23.5	
Hori	9920.000	PK	43.9	38.6	6.1	33.5	55.1	73.9	18.8	
Hori	2483.500	AV	33.0	27.5	2.6	32.4	30.7	53.9	23.2	
Hori	3377.746	AV	34.0	28.9	3.1	32.0	34.0	53.9	19.9	
Hori	4960.000	AV	32.1	31.8	4.4	31.6	36.7	53.9	17.2	
Hori	7440.000	AV	30.4	35.9	5.3	32.8	38.8	53.9	15.1	
Hori	9920.000	AV	31.5	38.6	6.1	33.5	42.7	53.9	11.2	
Vert	42.000	QP	23.0	14.0	7.3	32.2	12.1	40.0	27.9	
Vert	96.200	QP	29.8	9.7	8.0	32.1	15.4	43.5	28.1	
Vert	111.000	QP	29.9	12.2	8.2	32.1	18.2	43.5	25.3	
Vert	150.790	QP	35.4	15.1	8.6	32.1	27.0	43.5	16.5	
Vert	406.998	QP	28.4	17.9	10.5	32.0	24.8	46.0	21.2	
Vert	610.000	QP	22.0	20.2	11.6	32.1	21.7	46.0	24.3	
Vert	2483.500	PK	44.0	27.5	2.6	32.4	41.7	73.9	32.2	
Vert	3377.901	PK	47.6	28.9	3.1	32.0	47.6	73.9	26.3	
Vert	4960.000	PK	41.8	31.8	4.4	31.6	46.4	73.9	27.5	
Vert	7440.000	PK	42.4	35.9	5.3	32.8	50.8	73.9	23.1	
Vert	9920.000	PK	44.0	38.6	6.1	33.5	55.2	73.9	18.7	
Vert	2483.500	AV	32.0	27.5	2.6	32.4	29.7	53.9	24.2	
Vert	3377.901	AV	32.7	28.9	3.1	32.0	32.7	53.9	21.2	
Vert	4960.000	AV	31.6	31.8	4.4	31.6	36.2	53.9	17.7	
Vert	7440.000	AV	30.3	35.9	5.3	32.8	38.7	53.9	15.2	
Vert	9920.000	AV	31.6	38.6	6.1	33.5	42.8	53.9	11.1	

Result = Reading + Ant Factor + Loss (Cable+Attenuator+Filter-Distance factor(above 10GHz)) - Gain(Amplifier)

*Other frequency noises omitted in this report were not seen or had enough margin (more than 20dB).

*The 10th harmonic was not seen so the result was its base noise level.
Distance factor: 10GHz-26.5GHz 20log(3.0m/1.0m)= 9.5dB