



RADIO TEST REPORT

Test Report No. : 10607274H-C-R1

Applicant : MITSUBISHI ELECTRIC CORPORATION SANDA WORKS
Type of Equipment : HEADUNIT A-HIGH
Model No. : NR-213
FCC ID : UJHNR213
Test regulation : FCC Part 15 Subpart E: 2015
Test Result : Complied

1. This test report shall not be reproduced in full or partial, without the written approval of UL Japan, Inc.
2. The results in this report apply only to the sample tested.
3. This sample tested is in compliance with above regulation.
4. The test results in this report are traceable to the national or international standards.
5. This test report must not be used by the customer to claim product certification, approval, or endorsement by NVLAP, NIST, or any agency of the Federal Government.
6. This test report covers Radio technical requirements. It does not cover administrative issues such as Manual or non-Radio test related Requirements. (if applicable)
7. This report is a revised version of 10607274H-C. 10607274H-C is replaced with this report.

Date of test: March 2 to June 24, 2015

Representative test engineer:

Tsubasa Takayama
Engineer

Consumer Technology Division

Approved by:

Takahiro Hatakeda
Leader

Consumer Technology Division



NVLAP LAB CODE: 200572-0

This laboratory is accredited by the NVLAP LAB CODE 200572-0, U.S.A. The tests reported herein have been performed in accordance with its terms of accreditation.
*As for the range of Accreditation in NVLAP, you may refer to the WEB address,
<http://www.ul.com/japan/jpn/pages/services/emc/about/mar1/index.jsp#nvlap>

UL Japan, Inc.
Ise EMC Lab.

4383-326 Asama-cho, Ise-shi, Mie-ken 516-0021 JAPAN
Telephone : +81 596 24 8999
Facsimile : +81 596 24 8124

CONTENTS	PAGE
SECTION 1: Customer information.....	4
SECTION 2: Equipment under test (E.U.T.).....	4
SECTION 3: Test specification, procedures & results.....	6
SECTION 4: Operation of E.U.T. during testing.....	9
SECTION 5: Radiated Spurious Emission and Band Edge Compliance	13
SECTION 6: Antenna Terminal Conducted Tests.....	15
APPENDIX 1: Data of EMI test.....	16
26dB Emission Bandwidth and 99% Occupied Bandwidth.....	16
20dB Bandwidth	26
6dB Bandwidth	33
Maximum Conducted Output Power	37
Maximum Power Spectral Density	42
Radiated Spurious Emission	50
Band Edge confirmation	83
Conducted Spurious Emission	90
APPENDIX 2: Test instruments	92
APPENDIX 3: Photographs of test setup	94
Radiated Spurious Emission	94
Worst Case Position	95

UL Japan, Inc.

Ise EMC Lab.

4383-326 Asama-cho, Ise-shi, Mie-ken 516-0021 JAPAN

Telephone : +81 596 24 8999

Facsimile : +81 596 24 8124

SECTION 1: Customer information

Company Name : MITSUBISHI ELECTRIC CORPORATION SANDA WORKS
Address : 2-3-33, Miwa, Sanda-city, Hyogo, 669-1513, Japan
Telephone Number : +81-79-559-3607
Facsimile Number : +81-79-559-3875
Contact Person : Yuji Funaba

SECTION 2: Equipment under test (E.U.T.)

2.1 Identification of E.U.T.

Type of Equipment : HEADUNIT A-HIGH
Model No. : NR-213
Serial No. : Refer to Clause 4.2
Rating : DC 12 V
Receipt Date of Sample : February 26, 2015
Country of Mass-production : Japan
Condition of EUT : Production prototype
(Not for Sale: This sample is equivalent to mass-produced items.)
Modification of EUT : No Modification by the test lab

UL Japan, Inc.

Ise EMC Lab.

4383-326 Asama-cho, Ise-shi, Mie-ken 516-0021 JAPAN

Telephone : +81 596 24 8999

Facsimile : +81 596 24 8124

2.2 Product Description

General Specification

Clock frequency(ies) in the system : 1.4 GHz,
40 MHz (Radio part)

Radio Specification

	IEEE802.11b	IEEE802.11g/n (20 M band)	IEEE802.11a/n (20 M band)	IEEE802.11n (40 M band)	Bluetooth Ver.3.0 with EDR function
Frequency of operation	2412-2462MHz	2412-2462MHz	5180-5240MHz *1) 5260-5320MHz *1) 5500-5700MHz *1) 5745-5825MHz *1)	5190-5230MHz *1) 5270-5310MHz *1) 5510-5670MHz *1) 5755-5795MHz *1)	2402-2480MHz
Type of modulation	DSSS (CCK, DQPSK, DBPSK)	OFDM-CCK (64QAM, 16QAM, QPSK, BPSK)	OFDM (64QAM, 16QAM, QPSK, BPSK)		FHSS (GFSK, $\pi/4$ -DQPSK, 8-DPSK)
Channel spacing	5MHz		20MHz		1MHz
Antenna type	Printed patch Antenna				Dipole Pattern Antenna
Antenna Gain	3.3dBi		6.5dBi		2.32dBi
Antenna Connector type	FAKRA				PSE-LP2

*1) This test report applies for WLAN (IEEE802.11a/n-20/n-40 [5180-5240MHz, 5190-5230MHz, 5260-5320MHz, 5270-5310MHz, 5500-5700MHz, 5510-5670MHz, 5745-5825MHz, and 5755-5795MHz]).

	GPS/GLONASS
Frequency of operation	GPS: 1575.42MHz GLONASS: 1597.55-1605.89MHz
Type of modulation	GPS: BPSK GLONASS: BPSK
Channel spacing	GLONASS: 0.5625MHz
Antenna type	Active antenna
Antenna Connector type	FAKRA
Antenna Gain	25dBi

UL Japan, Inc.

Ise EMC Lab.

4383-326 Asama-cho, Ise-shi, Mie-ken 516-0021 JAPAN

Telephone : +81 596 24 8999

Facsimile : +81 596 24 8124

SECTION 3: Test specification, procedures & results

3.1 Test Specification

Test Specification : FCC Part 15 Subpart E: 2015, final revised on January 21, 2015
Title : FCC 47CFR Part15 Radio Frequency Device Subpart E
Unlicensed National Information Infrastructure Devices
Section 15.407 General technical requirements

3.2 Procedures and results

Item	Test Procedure	Specification	Worst margin	Results	Remarks
Conducted Emission	FCC :ANSI C63.4:2009 IC: RSS-Gen 8.8	FCC: 15.407(b)(6) / 15.207 IC: RSS-Gen 8.8	N/A	N/A *1)	-
26dB Emission Bandwidth	FCC :ANSI C63.4:2009, FCC KDB Publication Number 789033 IC: -	FCC : 15.407(a)(1)(2)(3) IC: -	See data	N/A	Conducted
Maximum Conducted Output Power	FCC :ANSI C63.4:2009, FCC KDB Publication Number 789033 IC: -	FCC : 15.407(a)(1)(2)(3) IC: RSS-247 6.2.1(1) 6.2.2(1) 6.2.3(1) 6.2.4(1)		Complied	Conducted
Maximum Power Spectral Density	FCC :ANSI C63.4:2009, FCC KDB Publication Number 789033 IC: -	FCC : 15.407(a)(1)(2)(3) IC: RSS-247 6.2.1(1) 6.2.2(1) 6.2.3(1) 6.2.4(1)		Complied	Conducted
Spurious Emission Restricted Band Edge	FCC: ANSI C63.4:2009 IC: -	FCC : 15.407(b), 15.205 and 15.209 IC: RSS-247 6.2.1(2) 6.2.2(2) 6.2.3(2) 6.2.4(2)		1.4dB 2499.892MHz, AV, Hori.	Complied
20dB Emission Bandwidth	FCC :ANSI C63.4:2009	FCC : 15.215	See data	Complied	Conducted
6dB Emission Bandwidth	FCC :ANSI C63.4:2009 IC: -	FCC: 15.407(e) IC: RSS-247 6.2.4(1)	See data	Complied	Conducted

Note: UL Japan, Inc.'s EMI Work Procedures No. 13-EM-W0420 and 13-EM-W0422.
*1) The test is not applicable since the EUT is not the device that is designed to be connected to the public utility (AC) power line.
*2) Radiated test was selected over 30 MHz based on section FCC15.407(b) and KDB 789033 D02 G.3.b).
* For DFS tests, please see the test report number 10607274H-D-R1 issued by UL Japan, Inc.

FCC 15.31 (e)

The EUT provides stable voltage (DC 3.3 V) constantly to the wireless transmitter regardless of input voltage. Instead of a new battery, DC power supply was used for the test. That does not affect the test result, therefore the EUT complies with the requirement.

FCC Part 15.203 Antenna requirement

It is impossible for end users to replace the antenna, because the antenna is mounted inside of the Vehicle. Therefore, the equipment complies with the antenna requirement of Section 15.203.

UL Japan, Inc.

Ise EMC Lab.

4383-326 Asama-cho, Ise-shi, Mie-ken 516-0021 JAPAN

Telephone : +81 596 24 8999

Facsimile : +81 596 24 8124

3.3 Addition to standard

Item	Test Procedure	Specification	Worst margin	Results	Remarks
99% Occupied Band Width	RSS-Gen 6.6	IC: -	N/A	N/A	Conducted
Co-location & Co-operation (Confirmation testing for Radiated Spurious Emission at simultaneous transmission)	FCC: ANSI C63.4:2009	FCC : 15.407(b), 15.205 and 15.209	8.4 dB 982.506 MHz, Vertical, QP	Complied	Radiated *1)
	IC: -	IC: RSS-247 6.2.1(2) 6.2.2(2) 6.2.3(2) 6.2.4(2)			

*1) Radiated test was selected over 30 MHz based on section FCC15.407(b) and KDB 789033 D02 G.3.b). Other than above, no addition, exclusion nor deviation has been made from the standard.

3.4 Uncertainty

EMI

The following uncertainties have been calculated to provide a confidence level of 95% using a coverage factor k=2.

Test room (semi-anechoic chamber)	Radiated emission						
	(3m*)(+dB)				(1m*)(+dB)		(0.5m*)(+dB)
	9kHz -30MHz	30MHz -300MHz	300MHz -1GHz	1GHz -10GHz	10GHz -18GHz	18GHz -26.5GHz	26.5GHz -40GHz
No.1	4.3dB	5.5dB	6.3dB	5.5dB	5.8dB	5.8dB	4.3dB
No.2	4.2dB	5.4dB	6.3dB	5.4dB	5.7dB	5.9dB	5.6dB
No.3	4.4dB	5.4dB	6.4dB	5.2dB	5.5dB	5.8dB	5.5dB
No.4	4.7dB	5.6dB	6.4dB	5.3dB	5.7dB	5.9dB	5.5dB

*3m/1m/0.5m = Measurement distance

Antenna terminal conducted emission and Power density (+dB)			Antenna terminal conducted emission (+dB)		Channel power (+dB)
Below 1GHz	1GHz-3GHz	3GHz-18GHz	18GHz-26.5GHz	26.5GHz-40GHz	
1.5dB	1.7dB	2.8dB	2.8dB	2.9dB	2.6dB

Radiated emission test(3m)

The data listed in this report meets the limits unless the uncertainty is taken into consideration.

UL Japan, Inc.

Ise EMC Lab.

4383-326 Asama-cho, Ise-shi, Mie-ken 516-0021 JAPAN

Telephone : +81 596 24 8999

Facsimile : +81 596 24 8124

3.5 Test Location

UL Japan, Inc. Ise EMC Lab. *NVLAP Lab. code: 200572-0
4383-326 Asama-cho, Ise-shi, Mie-ken 516-0021 JAPAN
Telephone : +81 596 24 8999 Facsimile : +81 596 24 8124

	IC Registration Number	Width x Depth x Height (m)	Size of reference ground plane (m) / horizontal conducting plane	Other rooms
No.1 semi-anechoic chamber	2973C-1	19.2 x 11.2 x 7.7m	7.0 x 6.0m	No.1 Power source room
No.2 semi-anechoic chamber	2973C-2	7.5 x 5.8 x 5.2m	4.0 x 4.0m	-
No.3 semi-anechoic chamber	2973C-3	12.0 x 8.5 x 5.9m	6.8 x 5.75m	No.3 Preparation room
No.3 shielded room	-	4.0 x 6.0 x 2.7m	N/A	-
No.4 semi-anechoic chamber	2973C-4	12.0 x 8.5 x 5.9m	6.8 x 5.75m	No.4 Preparation room
No.4 shielded room	-	4.0 x 6.0 x 2.7m	N/A	-
No.5 semi-anechoic chamber	-	6.0 x 6.0 x 3.9m	6.0 x 6.0m	-
No.6 shielded room	-	4.0 x 4.5 x 2.7m	4.0 x 4.5 m	-
No.6 measurement room	-	4.75 x 5.4 x 3.0m	4.75 x 4.15 m	-
No.7 shielded room	-	4.7 x 7.5 x 2.7m	4.7 x 7.5m	-
No.8 measurement room	-	3.1 x 5.0 x 2.7m	N/A	-
No.9 measurement room	-	8.8 x 4.6 x 2.8m	2.4 x 2.4m	-
No.11 measurement room	-	6.2 x 4.7 x 3.0m	4.8 x 4.6m	-

* Size of vertical conducting plane (for Conducted Emission test) : 2.0 x 2.0m for No.1, No.2, No.3, and No.4 semi-anechoic chambers and No.3 and No.4 shielded rooms.

3.6 Data of EMI, Test instruments, and Test set up

Refer to APPENDIX.

UL Japan, Inc. Ise EMC Lab.

4383-326 Asama-cho, Ise-shi, Mie-ken 516-0021 JAPAN
Telephone : +81 596 24 8999
Facsimile : +81 596 24 8124

SECTION 4: Operation of E.U.T. during testing

4.1 Operating Modes

Test operating mode was determined as follows according to “Section 1 of 6 802.11 a/b/g/n testing- Managing Complex Regulatory Approvals - ” of TCB Council Workshop October 2009.

Mode	Remarks*
IEEE 802.11a (11a)	54Mbps, PN9
IEEE 802.11n 20MHz BW (11n-20)	MCS 7, PN9
IEEE 802.11n 40MHz BW (11n-40)	MCS 7, PN9
*The worst condition was determined based on the test result of Maximum Conducted Output Power.	
*Power of the EUT was set by the software as follows; - Power Setting: default - Software: Engineering mode E45.2 *This setting of software is the worst case. Any conditions under the normal use do not exceed the condition of setting. In addition, end users cannot change the settings of the output power of the product.	

UL Japan, Inc.

Ise EMC Lab.

4383-326 Asama-cho, Ise-shi, Mie-ken 516-0021 JAPAN

Telephone : +81 596 24 8999

Facsimile : +81 596 24 8124

*The details of Operating mode(s)

Test Item	Operating Mode	Tested Frequency			
		Lower Band	Middle Band	Additional Band	Upper Band
26dB Emission Bandwidth	11a Tx 11n-20 Tx	-	5260MHz 5300MHz 5320MHz	5500MHz 5580MHz 5700MHz	-
	11n-40 Tx	-	5270MHz 5310MHz	5510MHz 5590MHz 5670MHz	-
99% Occupied Bandwidth, Maximum Conducted Output Power, Maximum Power Spectral Density	11a Tx 11n-20 Tx	5180MHz 5220MHz 5240MHz	5260MHz 5300MHz 5320MHz	5500MHz 5580MHz 5700MHz	5745MHz 5785MHz 5825MHz
	11n-40 Tx	5190MHz 5230MHz	5270MHz 5310MHz	5510MHz 5590MHz 5670MHz	5755MHz 5795MHz
20dB Bandwidth	11a Tx 11n-20 Tx	5180MHz 5240MHz	5260MHz 5320MHz	5500MHz 5700MHz	5745MHz 5825MHz
	11n-40 Tx	5190MHz 5230MHz	5270MHz 5310MHz	5510MHz 5670MHz	5755MHz 5795MHz
Radiated Spurious Emission (Below 1GHz) *1)	11a Tx	5180MHz	-	-	-
	11n-40 Tx	5190MHz	-	-	-
Radiated Spurious Emission (Above 1GHz)	11a Tx	5180MHz	5260MHz 5320MHz	5500MHz 5580MHz 5700MHz	5745MHz 5785MHz 5825MHz
	11n-20 Tx	5180MHz	5320MHz	5500MHz 5700MHz	5745MHz 5825MHz
	11n-40 Tx	5190MHz	5270MHz 5310MHz	5510MHz 5550MHz 5670MHz	5755MHz 5795MHz
Conducted Spurious Emission *1)	11a Tx	5180MHz	-	-	-
	11n-40 Tx	5190MHz	-	-	-
6dB Bandwidth	11a Tx 11n-20 Tx	-	-	-	5745MHz 5785MHz 5825MHz
	11n-40 Tx	-	-	-	5755MHz 5795MHz
Radiated Spurious Emission (Co location transmitting) *1), *2)	11n-20 Tx (2412 MHz) + 11a Tx	5180MHz	5320MHz	5500MHz 5700MHz	5745MHz 5825MHz
	11n-20 Tx (2412 MHz) + 11n-20 Tx	5190MHz	5310MHz	5510MHz 5670MHz	5755MHz 5795MHz

*1) The operating mode and tested frequency were tested as a representative, because it had the highest power at antenna terminal test.

*2) These simultaneous transmission modes were selected based on worst power level. Therefore 2.4 GHz band maximum power channel was selected and performed with each lower and upper frequencies for 5 GHz bands using the same antenna. (Bluetooth simultaneous transmission was disregarded, as using the different antenna.)

4.2 Configuration and peripherals

[Radiated Spurious Emission test]

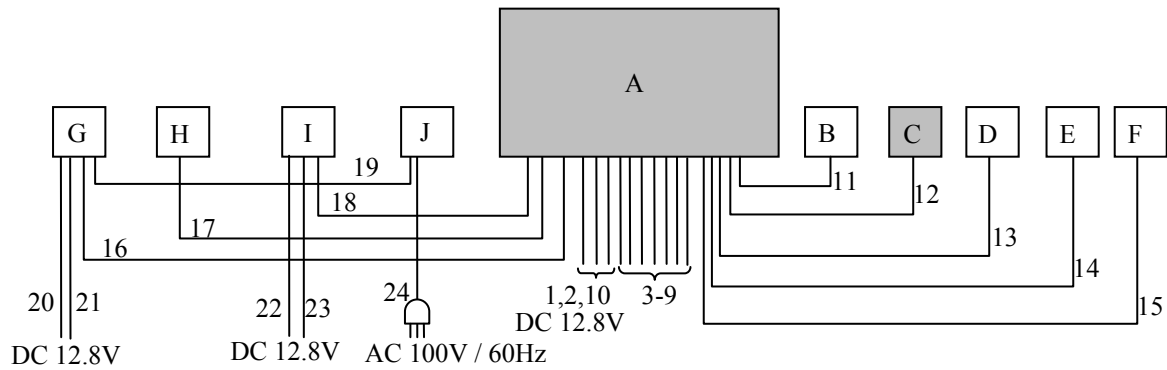

[Antenna Terminal Conducted tests]

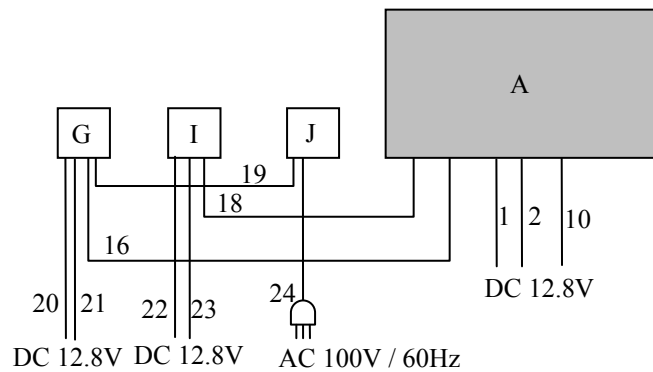

* Cabling and setup(s) were taken into consideration and test data was taken under worse case conditions.

* The testing was performed with DC 12.8 V only.

The voltage which the car battery mounted in the car outputs was selected as a test voltage according to the customer's request.

As the stable voltage (DC 3.3 V) is provided to RF module via the internal regulator, it does not influence on the test result.

UL Japan, Inc.

Ise EMC Lab.

4383-326 Asama-cho, Ise-shi, Mie-ken 516-0021 JAPAN

Telephone : +81 596 24 8999

Facsimile : +81 596 24 8124

Description of EUT and Support equipment

No.	Item	Model number	Serial number	Manufacturer	Remarks
A	HEADUNIT A-HIGH	NR-213	No 3-2 for RE* No 3-1 for AT*	mitsubishi electric CORPORATION SANDA WORKS	EUT
B	BT Antenna	050 978-A	38113	WiSi	-
C	WLAN Antenna	A2139058402	1234 00012	WiSi	EUT
D	GPS Antenna	-	-	mitsubishi electric CORPORATION SANDA WORKS	-
E	USB Memory	RFU-2	120301	BUFFALO	-
F	Dummy Load	-	-	mitsubishi electric CORPORATION SANDA WORKS	-
G	HSVL PCB	NTG 5.5 H0H	489	mitsubishi electric CORPORATION SANDA WORKS	-
H	HSVL PCB	NTG 5.5 H0H	487	mitsubishi electric CORPORATION SANDA WORKS	-
I	Controller	A 166 900 10 10	63358850202	Mercedes-Benz	-
J	LCD Monitor	EW2730-B	ETNAB07468S L0	BenQ	-

* RE: Radiated Spurious Emission test / AT: Antenna Terminal Conducted Tests

List of cables used

No.	Name	Length (m)	Shield		Remarks
			Cable	Connector	
1	DC Cable (+)	2.0	Unshielded	Unshielded	-
2	DC Cable (-)	2.0	Unshielded	Unshielded	-
3	Dummy Cable (Aux)	1.0	Shielded	Shielded	-
4	Dummy Cable (RUG)	1.0	Shielded	Shielded	-
5	Dummy Cable (Tune 1)	1.0	Shielded	Shielded	-
6	Dummy Cable (Tune 2)	1.0	Shielded	Shielded	-
7	Dummy Cable (Tune 3)	1.0	Shielded	Shielded	-
8	USB Cable 1	1.0	Shielded	Shielded	-
9	USB Cable 2	1.0	Shielded	Shielded	-
10	Main Harness	1.0	Unshielded	Unshielded	-
11	BT Antenna Cable	0.5	Shielded	Shielded	-
12	WLAN Antenna Cable	1.5	Shielded	Shielded	-
13	GPS Antenna Cable	5.0	Shielded	Shielded	-
14	USB Cable 3	1.0	Shielded	Shielded	-
15	Speaker Cable	0.5	Unshielded	Unshielded	-
16	HSLV Cable	1.0	Shielded	Shielded	-
17	HSLV Cable	1.0	Shielded	Shielded	-
18	Controller Cable	2.3	Shielded	Shielded	-
19	DVI Cable	3.0	Shielded	Shielded	-
20	DC Cable (+)	2.0	Shielded	Shielded	-
21	DC Cable (-)	2.0	Unshielded	Unshielded	-
22	DC Cable (+)	2.0	Unshielded	Unshielded	-
23	DC Cable (-)	2.0	Unshielded	Unshielded	-
24	AC Cable	2.0	Unshielded	Unshielded	-

UL Japan, Inc.

Ise EMC Lab.

4383-326 Asama-cho, Ise-shi, Mie-ken 516-0021 JAPAN

Telephone : +81 596 24 8999

Facsimile : +81 596 24 8124

SECTION 5: Radiated Spurious Emission and Band Edge Compliance

Test Procedure

EUT was placed on a urethane platform of nominal size, 1.0m by 2.0m, raised 0.8m above the conducting ground plane.

The Radiated Electric Field Strength has been measured in a Semi Anechoic Chamber with a ground plane.

The height of the measuring antenna varied between 1 and 4m and EUT was rotated a full revolution in order to obtain the maximum value of the electric field strength.

The measurements were made with the following detector function of the test receiver and the Spectrum analyzer (in linear mode).

The measurements were performed for both vertical and horizontal antenna polarization with the Test Receiver, or the Spectrum Analyzer.

The test was made with the detector (RBW/VBW) in the following table.

When using Spectrum analyzer, the test was made with adjusting span to zero by using peak hold.

Below 1GHz

The result also satisfied with the general limits specified in section 15.209(a).

Above 1GHz

Inside of restricted bands(Section 15.205): Apply to limit in the Section 15.209(a).

Outside of the restricted bands: Apply to limit 68.2dBuV/m(-27dBm e.i.r.p. *)
in the Section 15.407(b)(1)(2)(3).

Apply to limit 68.2dBuV/m(-27dBm e.i.r.p. *) or
78.2dBuV/m(-17dBm e.i.r.p. *) in the Section 15.407(b).

Restricted bandedge:

Apply to limit in the Section 15.209(a).

Since this limit is severer than the limit of the inside of restricted bands.

*Electric Field Strength to e.i.r.p. Conversion

$$E = \frac{1000000\sqrt{30P}}{3} \text{ (uV/m)} \quad : P \text{ is the e.i.r.p. (Watts)}$$

Test Antennas are used as below;

Frequency	30MHz to 300MHz	300MHz to 1GHz	Above 1GHz
Antenna Type	Biconical	Logperiodic	Horn

Frequency	Below 1GHz	Above 1GHz	
Instrument used	Test Receiver	Spectrum Analyzer	
Detector	QP	PK	AV
IF Bandwidth	BW 120kHz(T/R)	RBW: 1MHz VBW: 3MHz	Method AD *1) RBW: 1MHz VBW: 3MHz Detector: Power Averaging (RMS) Duty factor was added to the results.
Test Distance	3m	3m (below 10GHz), 1m*2) (above 10GHz), 0.5m*3) (above 26.5GHz)	

*1) The test method was also referred to KDB 789033 D02 General UNII Test Procedures New Rules v01 "Guidelines for Compliance Testing of Unlicensed National Information Infrastructure (U-NII) Devices Part 15, Subpart E (Issued on June 6, 2014)".

*2) Distance Factor: $20 \times \log(3.0\text{m}/1.0\text{m}) = 9.5\text{dB}$

*3) Distance Factor: $20 \times \log(3.0\text{m}/0.5\text{m}) = 15.6\text{dB}$

UL Japan, Inc.

Ise EMC Lab.

4383-326 Asama-cho, Ise-shi, Mie-ken 516-0021 JAPAN

Telephone : +81 596 24 8999

Facsimile : +81 596 24 8124

[WLAN antenna]

- The carrier level and noise levels were confirmed at each position of X, Y and Z axes of WLAN antenna to see the position of maximum noise, and the test was made at the position that has the maximum noise.

[HEADUNIT A-HIGH]

-The test was made on EUT at the normal use position.

The test results and limit are rounded off to one decimal place, so some differences might be observed.

Measurement range : 30M-40GHz
Test data : APPENDIX
Test result : Pass

UL Japan, Inc.

Ise EMC Lab.

4383-326 Asama-cho, Ise-shi, Mie-ken 516-0021 JAPAN

Telephone : +81 596 24 8999

Facsimile : +81 596 24 8124

SECTION 6: Antenna Terminal Conducted Tests

Test Procedure

The tests were made with below setting connected to the antenna port with Spectrum Analyzer.

Test	Span	RBW	VBW	Sweep time	Detector	Trace	Instrument used and Test method
26dB Bandwidth	40MHz, 80MHz	Close to 1% of EBW	Greater than RBW	Auto	Peak	Max Hold	Spectrum Analyzer
99% Occupied Bandwidth	Enough width to display emission skirts	1 to 5% of OBW	≥ 3 RBW	Auto	Peak	Max Hold *1)	Spectrum Analyzer
20dB Bandwidth	40MHz, 80MHz	100kHz	300kHz	Auto	Peak	Max Hold	Spectrum Analyzer
6dB Bandwidth	40MHz, 80MHz	100kHz	300kHz	Auto	Peak	Max Hold	Spectrum Analyzer
Maximum Conducted Output Power	-	-	-	Auto	Averaging	-	Power Meter (Sensor: 80MHz BW) (Method PM)
Maximum Power Spectral Density	40MHz, 80MHz	1MHz or 470kHz *2)	3MHz or 1.5MHz	Auto	Sample Power Averaging (200 times)	Clear Write	Spectrum Analyzer
Conducted Spurious Emission*3)	9kHz-150kHz 150kHz-30MHz	200Hz 9.1kHz	620Hz 27kHz	Auto	Peak	Max Hold	Spectrum Analyzer
Band Edge confirmation *4)	80 MHz	1 MHz	10kHz, 3MHz	Auto	Average / Peak	Max Hold	Spectrum Analyzer (Method VB)

*The test method was also referred to KDB 789033 D02 General UNII Test Procedures New Rules v01 "Guidelines for Compliance Testing of Unlicensed National Information Infrastructure (U-NII) Devices Part 15, Subpart E (Issued on June 6, 2014)".

*1) The measurement was performed with Max Hold since the duty cycle was not 100%.

*2) FCC standard says that RBW is set to be 500kHz for 5.725-5.850GHz, but it is not possible with spectrum analyzer, so 10log(500kHz/470kHz) was added to the test result.

*3) In the frequency range below 30MHz, RBW was narrowed to separate the noise contents.

Then, wide-band noise near the limit was checked separately, however the noise was not detected as shown in the chart.(9kHz-150kHz:RBW=200Hz, 150kHz-30MHz:RBW=9.1kHz)

*4) Reference data

The test results and limit are rounded off to two decimals place, so some differences might be observed.

Test data : APPENDIX
Test result : Pass

APPENDIX 1: Data of EMI test

26dB Emission Bandwidth and 99% Occupied Bandwidth

Test place Ise EMC Lab. No.11 Measurement Room
Report No. 10607274H
Date 03/02/2015 03/03/2015
Temperature/ Humidity 23deg. C / 32% 22deg. C / 33% RH
Engineer Tsubasa Takayama Tsubasa Takayama
Mode 11a Tx / 11n-20 Tx / 11n-40 Tx

11a

Frequency [MHz]	26dB Emission Bandwidth [MHz]	99% Occupied Bandwidth [MHz]	Limit [MHz]
5180	-	16.7721	-
5220	-	16.7832	-
5240	-	16.7838	-
5260	19.634	16.7894	-
5300	19.619	16.7476	-
5320	19.598	16.7679	-
5500	19.440	16.8024	-
5580	19.520	16.7154	-
5700	19.627	16.7780	-
5745	-	16.7602	-
5785	-	16.7849	-
5825	-	16.7629	-

11n-20

Frequency [MHz]	26dB Emission Bandwidth [MHz]	99% Occupied Bandwidth [MHz]	Limit [MHz]
5180	-	17.8659	-
5220	-	17.8829	-
5240	-	17.9230	-
5260	20.410	17.7433	-
5300	19.798	17.8380	-
5320	20.004	17.8078	-
5500	20.016	17.7670	-
5580	19.896	17.8120	-
5700	20.337	17.7843	-
5745	-	17.8219	-
5785	-	17.8274	-
5825	-	17.8835	-

11n-40

Frequency [MHz]	26dB Emission Bandwidth [MHz]	99% Occupied Bandwidth [MHz]	Limit [MHz]
5190.0	-	36.5594	-
5230.0	-	36.3470	-
5270.0	40.121	36.4332	-
5310.0	40.923	36.3859	-
5510.0	40.850	36.4802	-
5590.0	40.456	36.4369	-
5670.0	39.766	36.4456	-
5755.0	-	36.4092	-
5795.0	-	36.4577	-

26dB Emission Bandwidth

11a

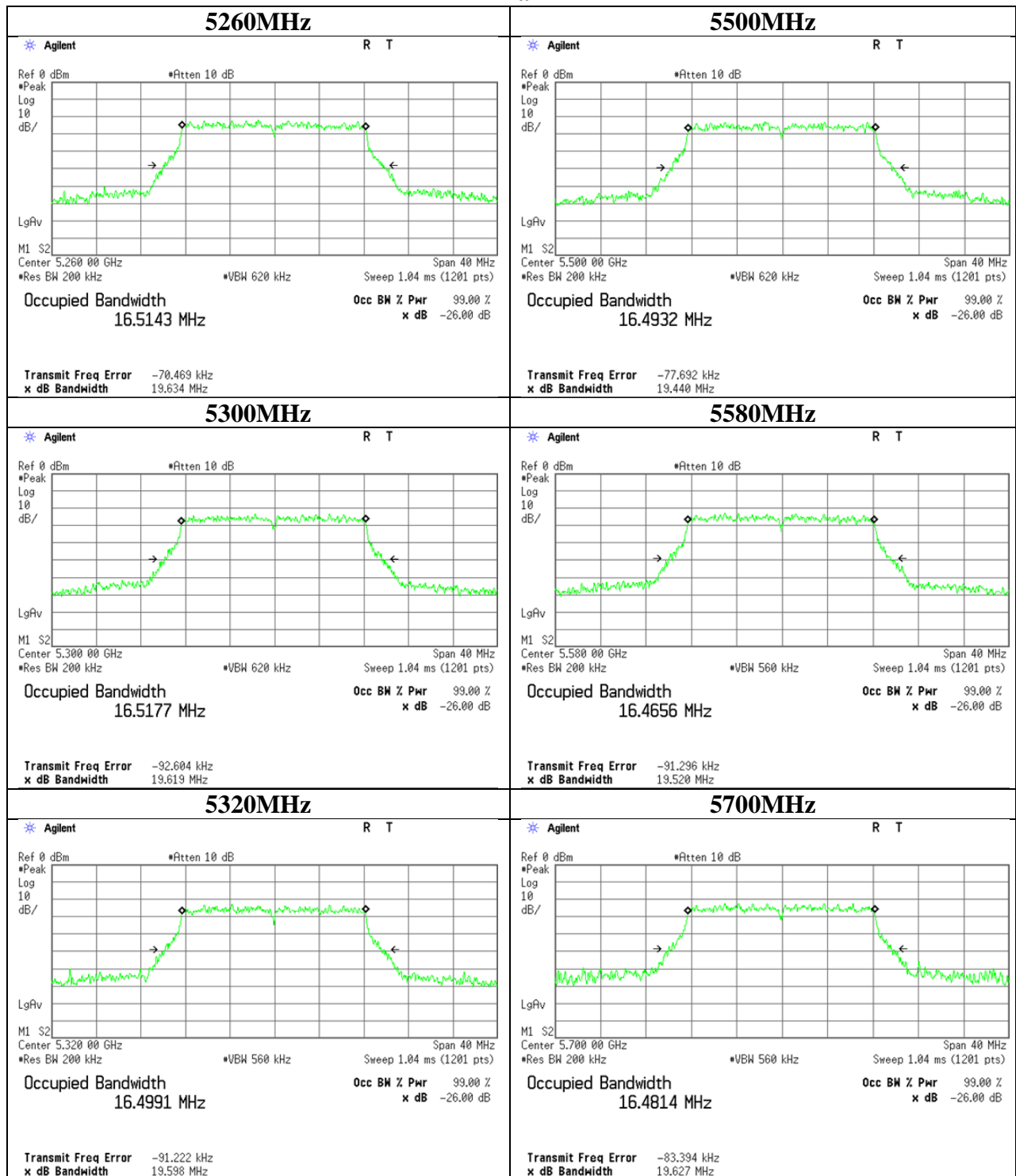

UL Japan, Inc.
Ise EMC Lab.

4383-326 Asama-cho, Ise-shi, Mie-ken 516-0021 JAPAN
 Telephone : +81 596 24 8999
 Facsimile : +81 596 24 8124

26dB Emission Bandwidth

11n-20

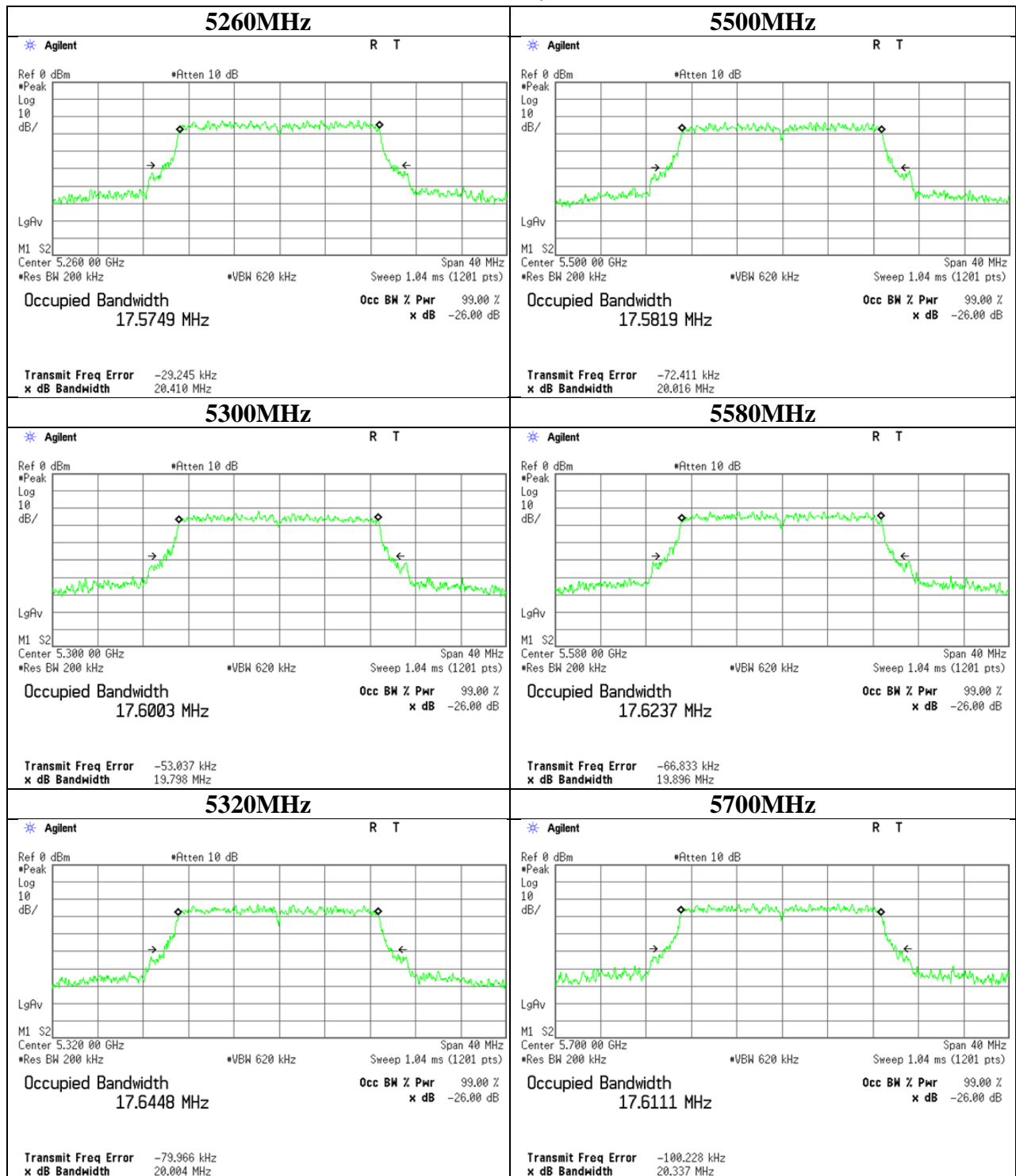

UL Japan, Inc.
Ise EMC Lab.

4383-326 Asama-cho, Ise-shi, Mie-ken 516-0021 JAPAN
 Telephone : +81 596 24 8999
 Facsimile : +81 596 24 8124

26dB Emission Bandwidth

11n-40

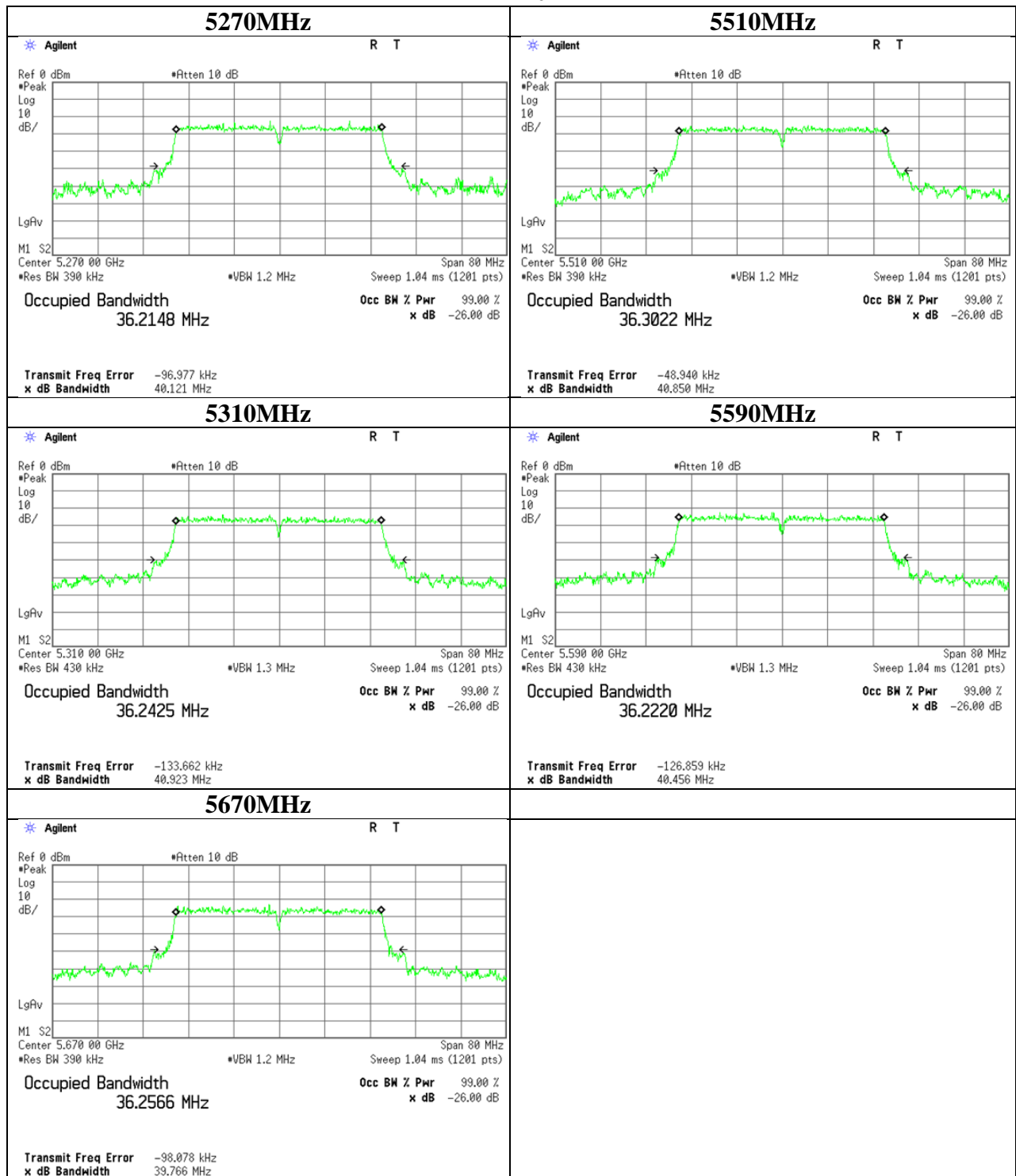

UL Japan, Inc.
Ise EMC Lab.

4383-326 Asama-cho, Ise-shi, Mie-ken 516-0021 JAPAN
 Telephone : +81 596 24 8999
 Facsimile : +81 596 24 8124

99% Occupied Bandwidth

11a

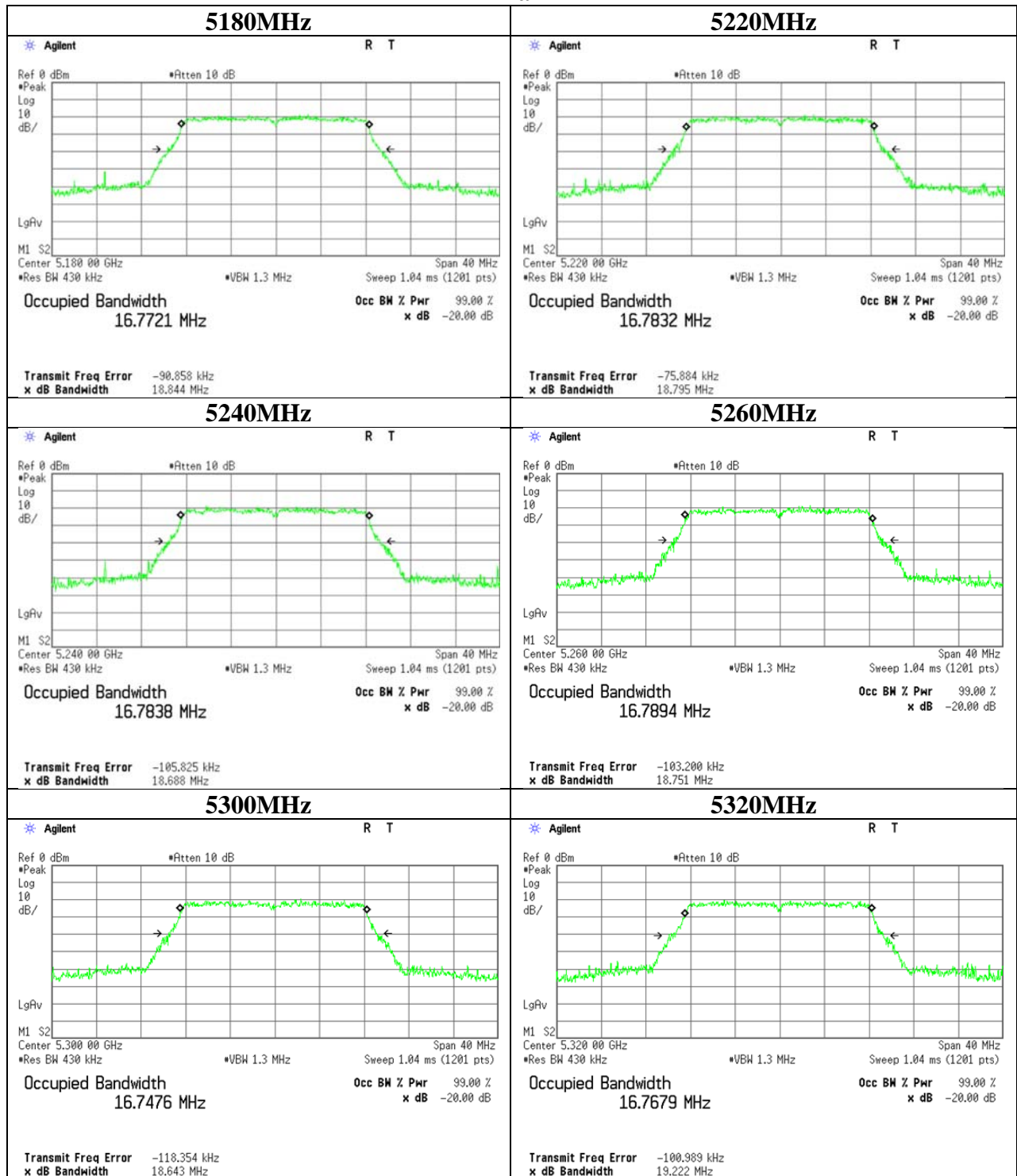

UL Japan, Inc.
Ise EMC Lab.

4383-326 Asama-cho, Ise-shi, Mie-ken 516-0021 JAPAN
 Telephone : +81 596 24 8999
 Facsimile : +81 596 24 8124

99% Occupied Bandwidth

11a

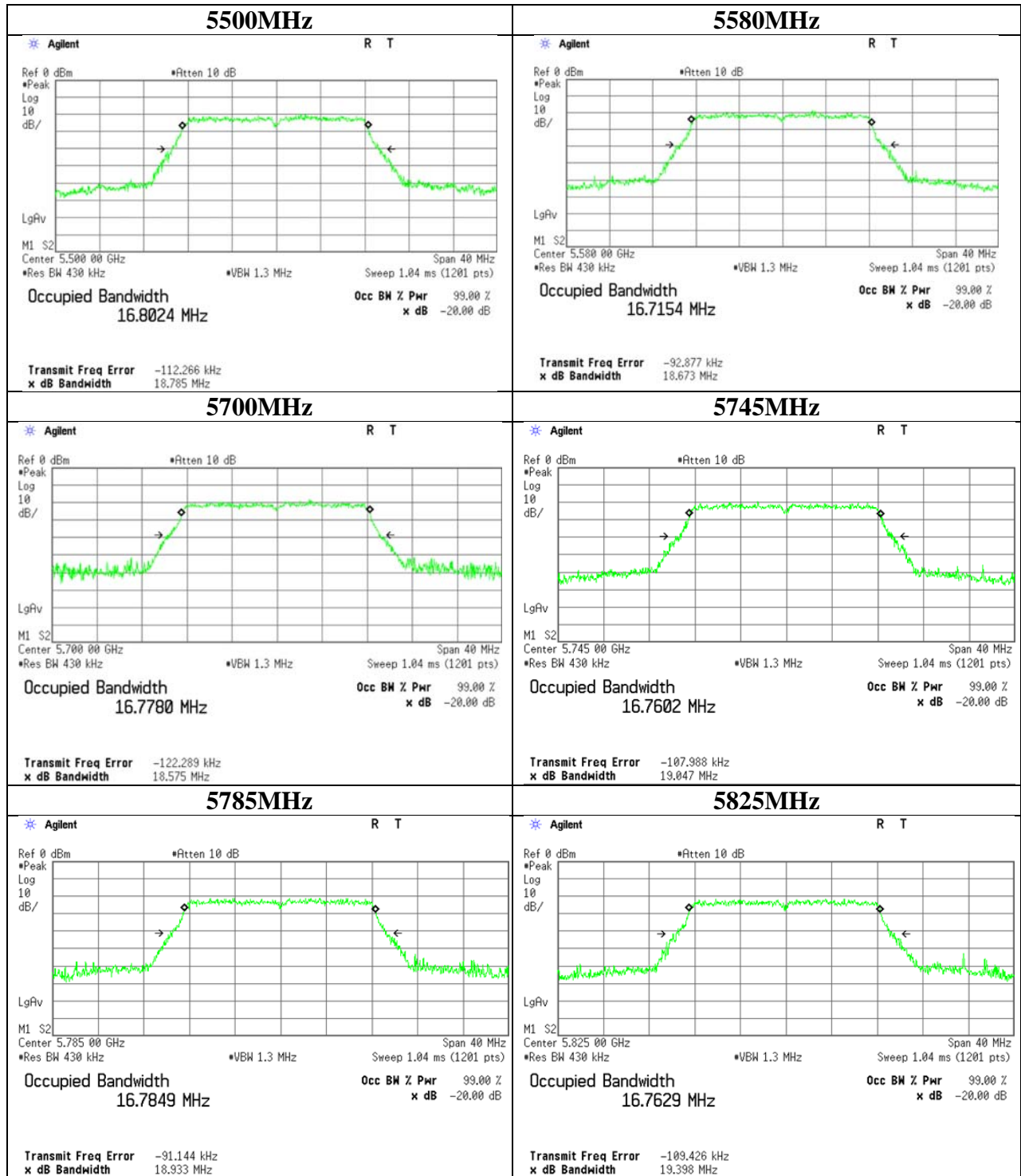

UL Japan, Inc.
Ise EMC Lab.

4383-326 Asama-cho, Ise-shi, Mie-ken 516-0021 JAPAN
 Telephone : +81 596 24 8999
 Facsimile : +81 596 24 8124

99% Occupied Bandwidth

11n-20

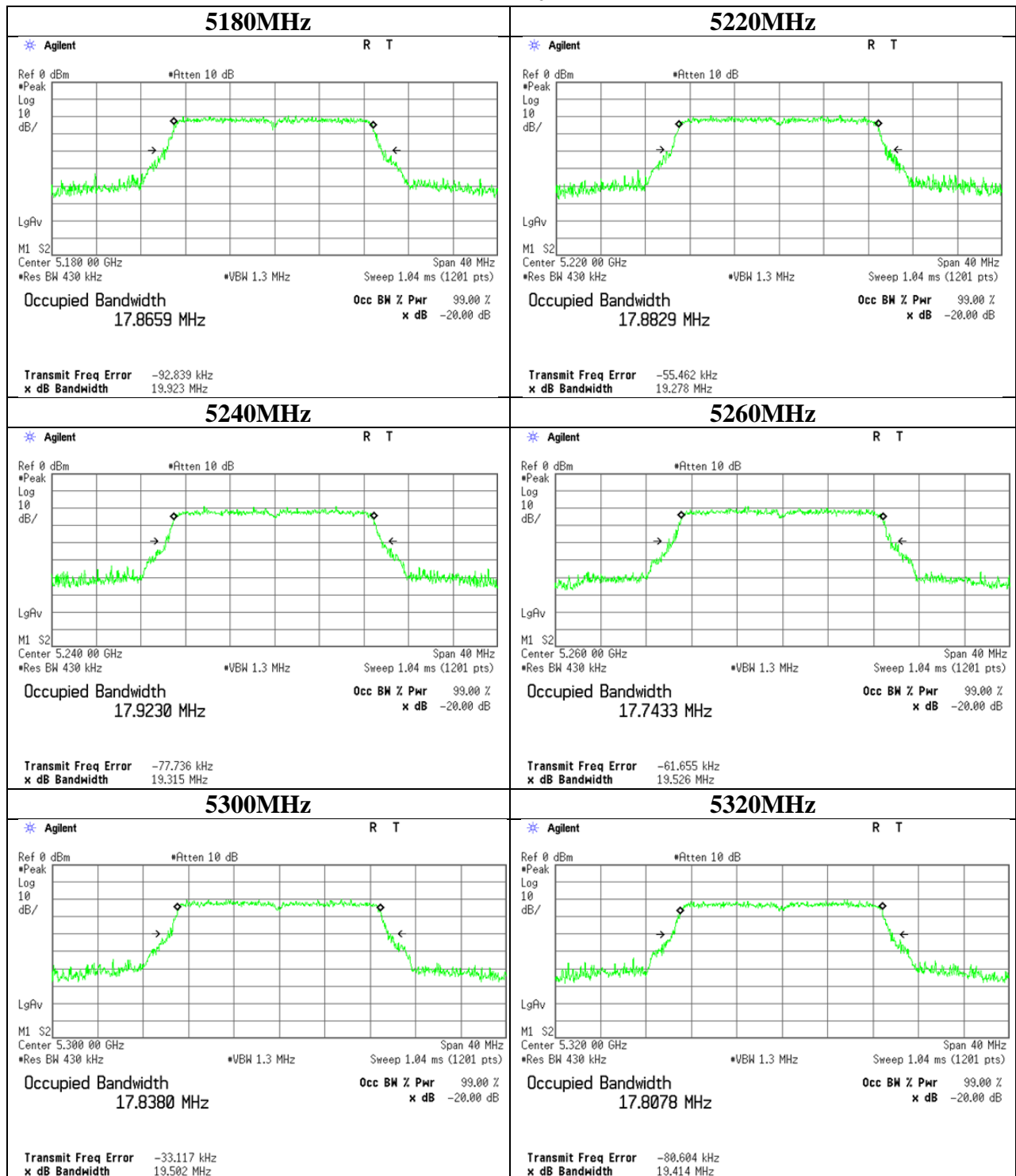

UL Japan, Inc.
Ise EMC Lab.

4383-326 Asama-cho, Ise-shi, Mie-ken 516-0021 JAPAN

Telephone : +81 596 24 8999

Facsimile : +81 596 24 8124

99% Occupied Bandwidth

11n-20

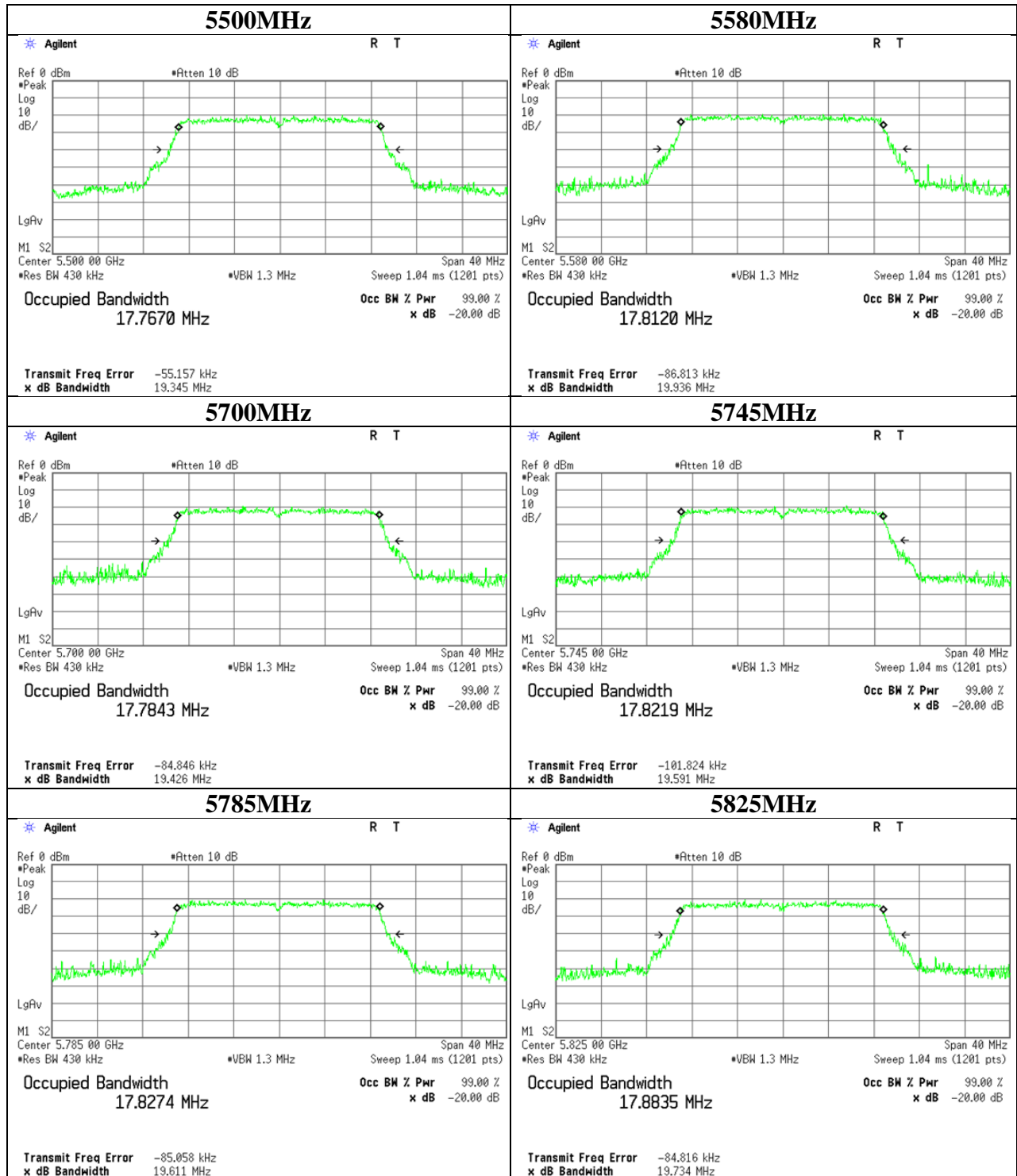

UL Japan, Inc.
Ise EMC Lab.

4383-326 Asama-cho, Ise-shi, Mie-ken 516-0021 JAPAN
 Telephone : +81 596 24 8999
 Facsimile : +81 596 24 8124

99% Occupied Bandwidth

11n-40

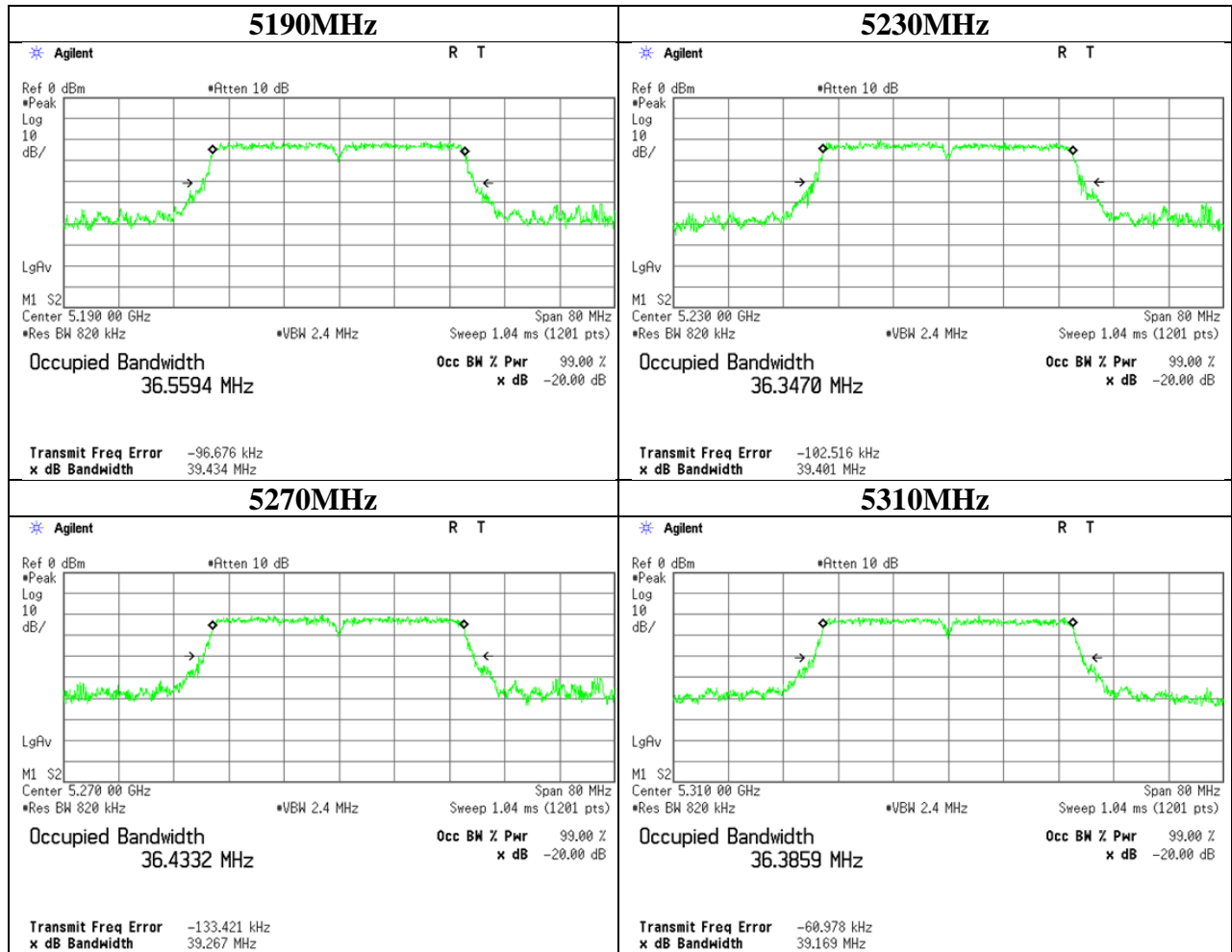

UL Japan, Inc.
Ise EMC Lab.

4383-326 Asama-cho, Ise-shi, Mie-ken 516-0021 JAPAN
 Telephone : +81 596 24 8999
 Facsimile : +81 596 24 8124

99% Occupied Bandwidth

11n-40

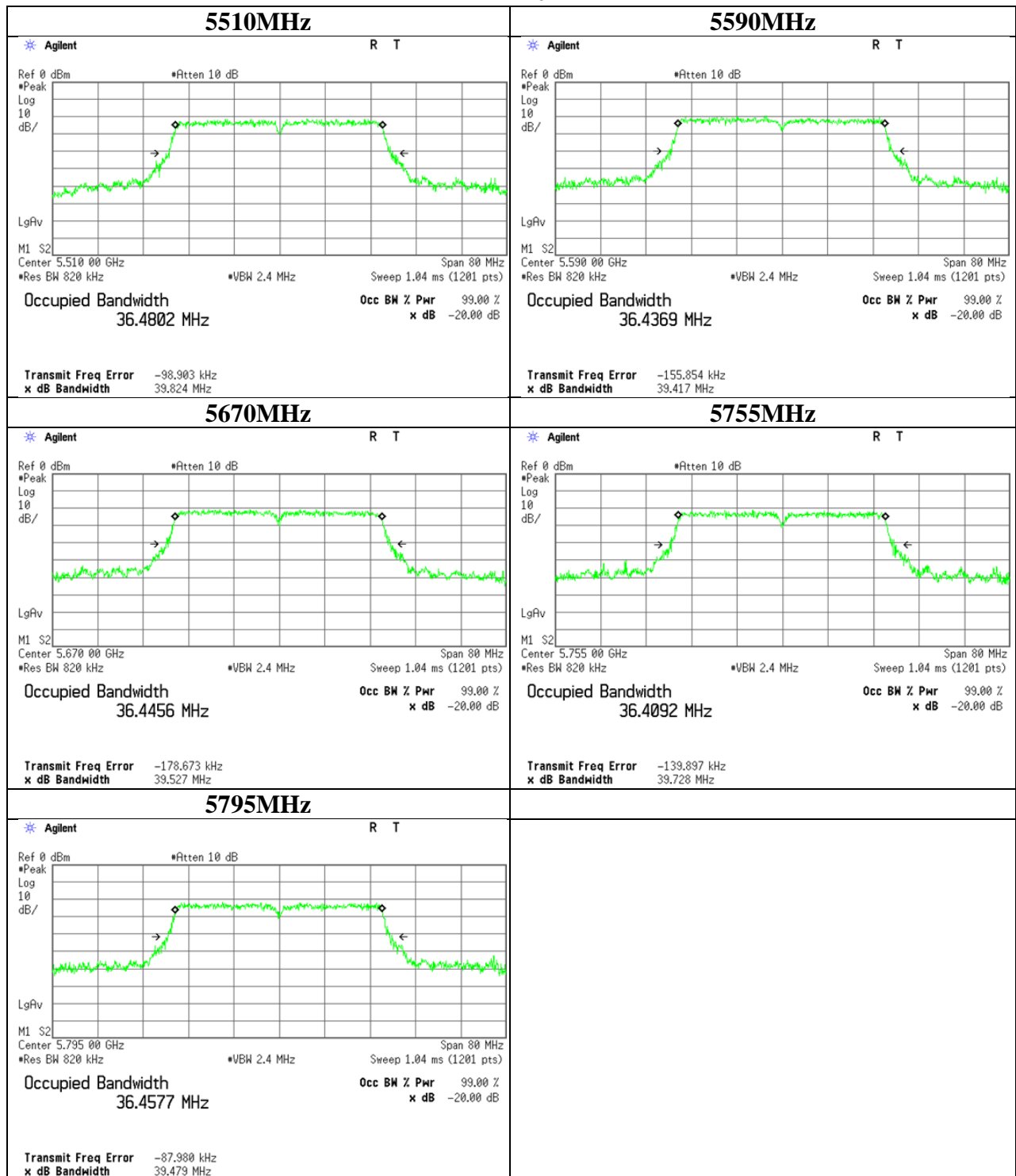

UL Japan, Inc.

Ise EMC Lab.

4383-326 Asama-cho, Ise-shi, Mie-ken 516-0021 JAPAN

Telephone : +81 596 24 8999

Facsimile : +81 596 24 8124

20dB Bandwidth

Test place	Ise EMC Lab. No.11 Measurement Room	
Report No.	10607274H	
Date	03/02/2015	03/03/2015
Temperature/ Humidity	23deg. C / 32%	22deg. C / 33% RH
Engineer	Tsubasa Takayama	Tsubasa Takayama
Mode	11a Tx / 11n-20 Tx / 11n-40 Tx	

11a

Frequency [MHz]	20dB Bandwidth [MHz]	Limit [MHz]
5180	17.354	-
5240	17.519	-
5260	17.337	-
5320	17.494	-
5500	17.534	-
5700	17.540	-
5745	17.431	-
5825	17.486	-

11n-20

Frequency [MHz]	20dB Bandwidth [MHz]	Limit [MHz]
5180	18.315	-
5240	18.485	-
5260	18.387	-
5320	18.375	-
5500	18.339	-
5700	18.343	-
5745	18.274	-
5825	18.377	-

11n-40

Frequency [MHz]	20dB Emission Bandwidth [MHz]	Limit [MHz]
5190.0	37.144	-
5230.0	37.179	-
5270.0	37.199	-
5310.0	37.127	-
5510.0	37.142	-
5670.0	37.131	-
5755.0	37.165	-
5795.0	37.172	-

20dB Bandwidth

11a

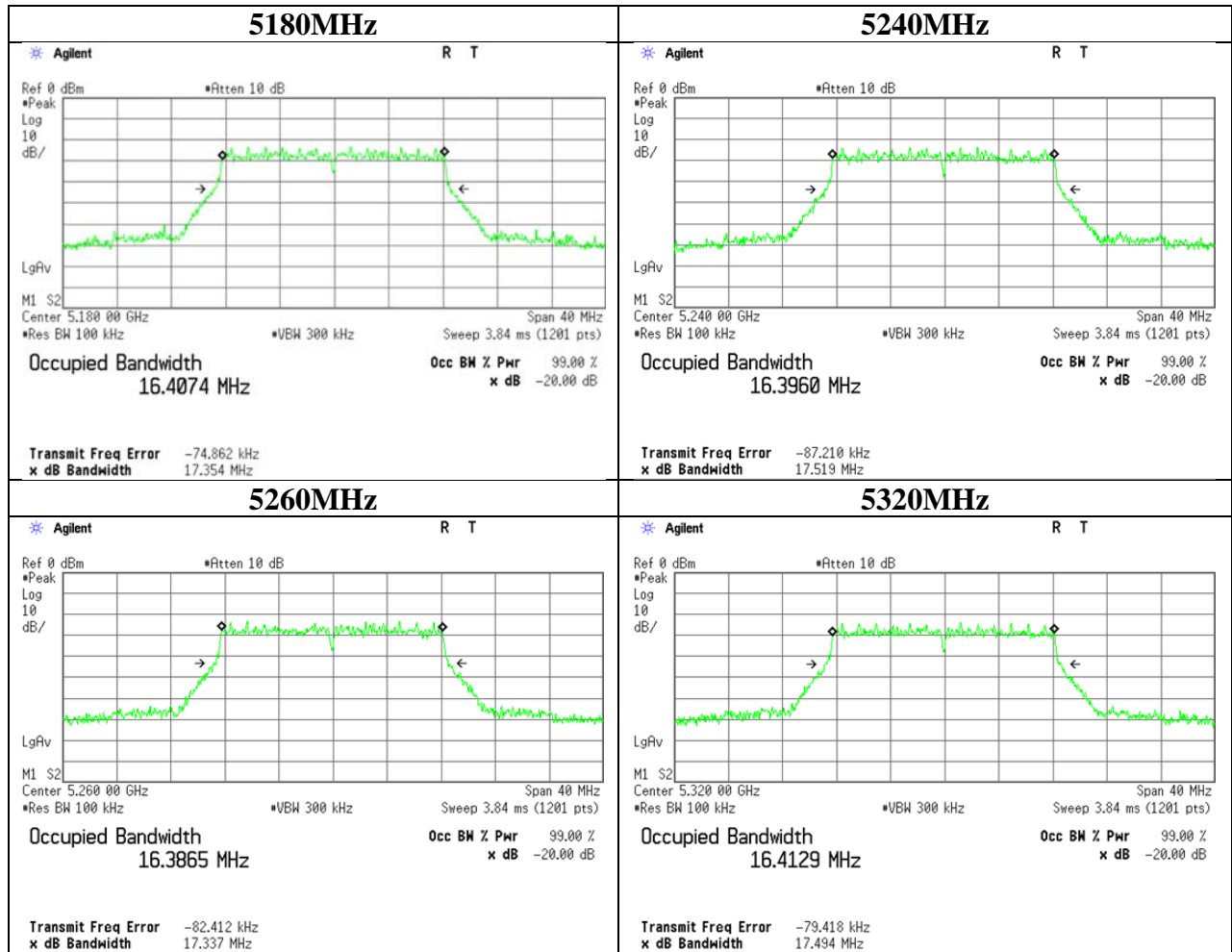

UL Japan, Inc.
Ise EMC Lab.

4383-326 Asama-cho, Ise-shi, Mie-ken 516-0021 JAPAN
 Telephone : +81 596 24 8999
 Facsimile : +81 596 24 8124

20dB Bandwidth

11a

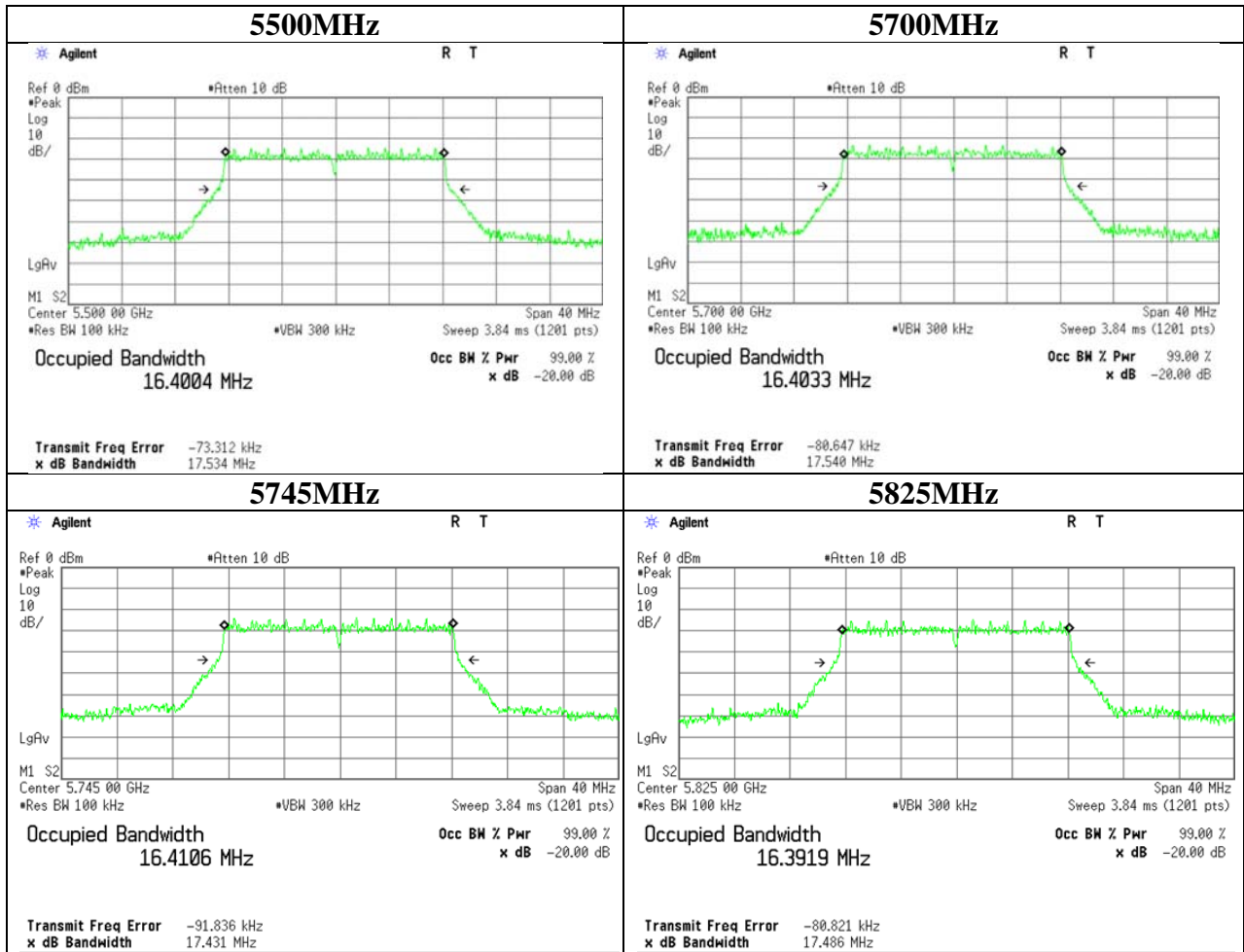

UL Japan, Inc.
Ise EMC Lab.

4383-326 Asama-cho, Ise-shi, Mie-ken 516-0021 JAPAN
 Telephone : +81 596 24 8999
 Facsimile : +81 596 24 8124

20dB Bandwidth

11n-20

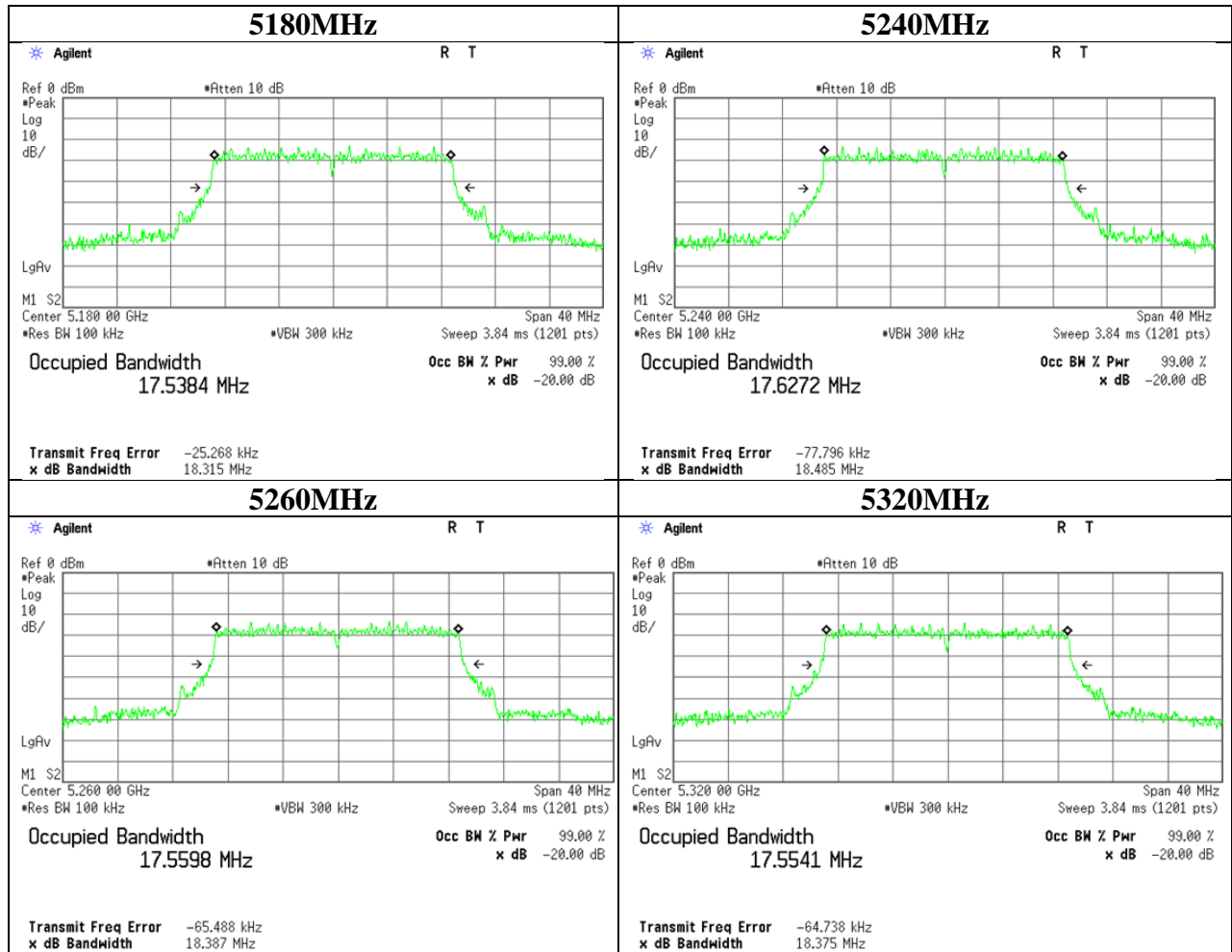

UL Japan, Inc.
Ise EMC Lab.

4383-326 Asama-cho, Ise-shi, Mie-ken 516-0021 JAPAN
 Telephone : +81 596 24 8999
 Facsimile : +81 596 24 8124

20dB Bandwidth

11n-20

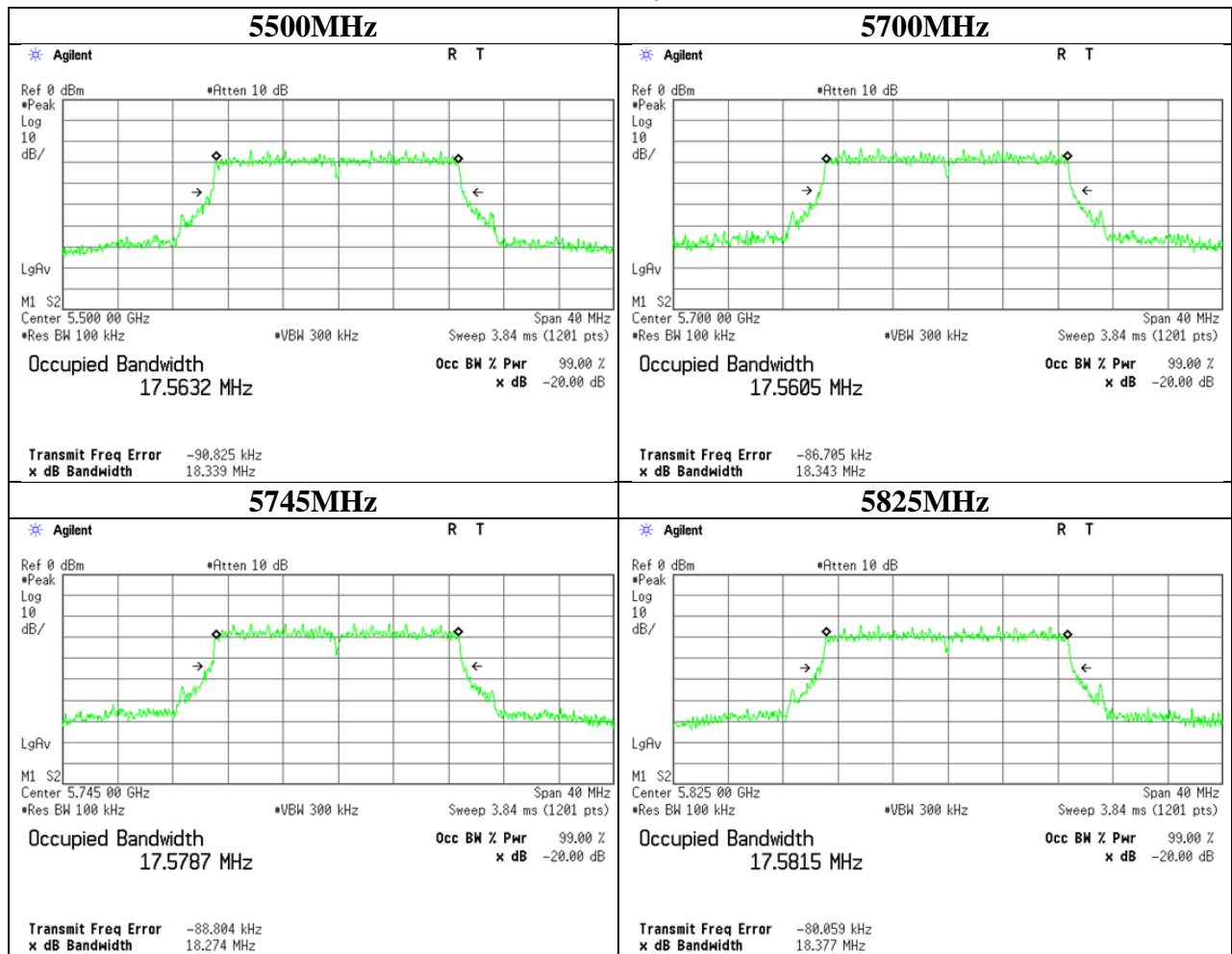

UL Japan, Inc.
Ise EMC Lab.

4383-326 Asama-cho, Ise-shi, Mie-ken 516-0021 JAPAN
 Telephone : +81 596 24 8999
 Facsimile : +81 596 24 8124

20dB Bandwidth

11n-40

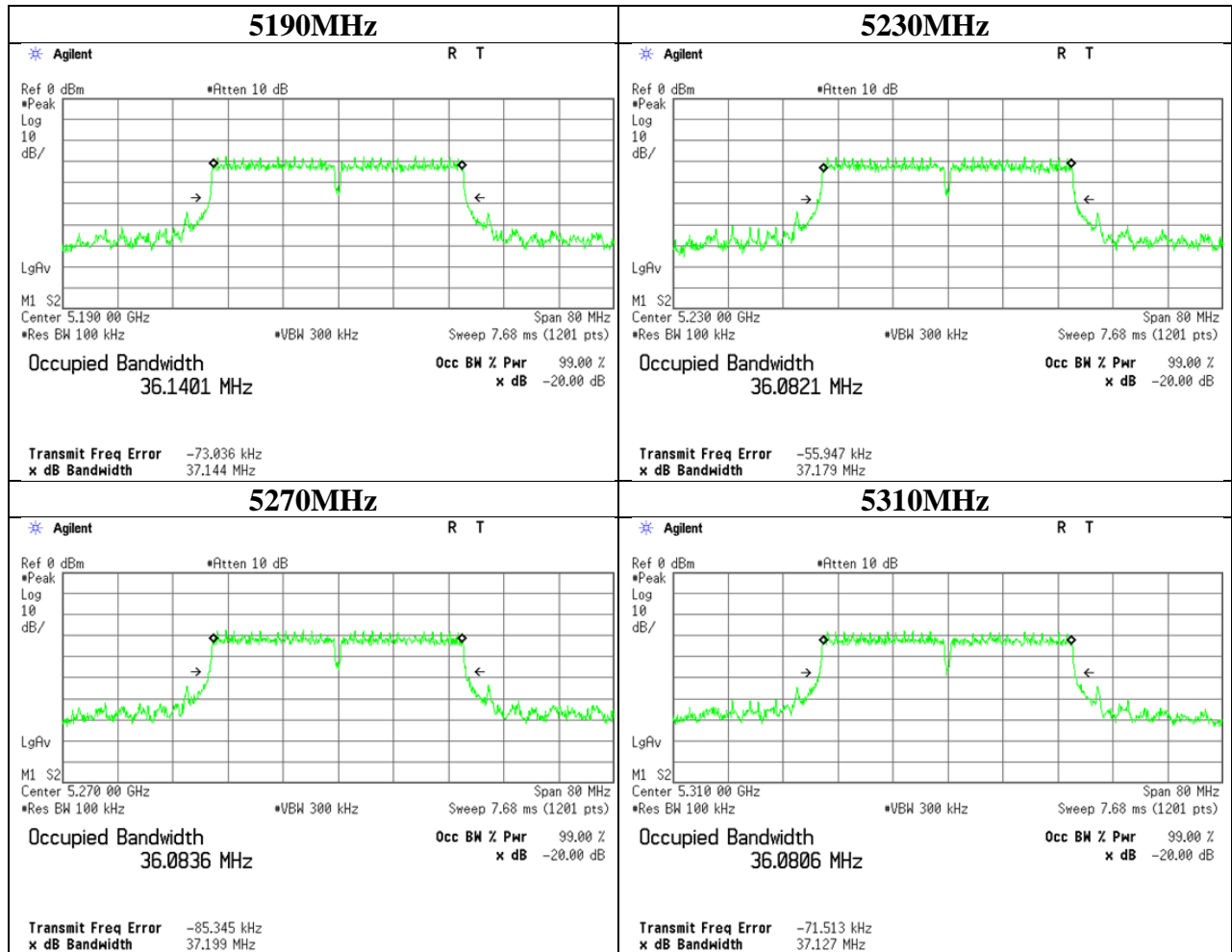

UL Japan, Inc.
Ise EMC Lab.

4383-326 Asama-cho, Ise-shi, Mie-ken 516-0021 JAPAN
 Telephone : +81 596 24 8999
 Facsimile : +81 596 24 8124