



RADIO TEST REPORT

Test Report No. : 10607274H-A-R1

Applicant : MITSUBISHI ELECTRIC CORPORATION SANDA WORKS

Type of Equipment : HEADUNIT A-HIGH

Model No. : NR-213

FCC ID : UJHNR213

Test regulation : FCC Part 15 Subpart C: 2015 (WLAN Part)

Test Result : Complied

1. This test report shall not be reproduced in full or partial, without the written approval of UL Japan, Inc.
2. The results in this report apply only to the sample tested.
3. This sample tested is in compliance with the above regulation.
4. The test results in this report are traceable to the national or international standards.
5. This test report must not be used by the customer to claim product certification, approval, or endorsement by NVLAP, NIST, or any agency of the Federal Government.
6. This test report covers Radio technical requirements. It does not cover administrative issues such as Manual or non-Radio test related Requirements. (if applicable)
7. This report is a revised version of 10607274H-A. 10607274H-A is replaced with this report.

Date of test: February 27 to June 24, 2015

Representative test engineer:

Tsubasa Takayama
Engineer

Consumer Technology Division

Approved by:

Takahiro Hatakeda
Leader

Consumer Technology Division



NVLAP LAB CODE: 200572-0

This laboratory is accredited by the NVLAP LAB CODE 200572-0, U.S.A. The tests reported herein have been performed in accordance with its terms of accreditation. *As for the range of Accreditation in NVLAP, you may refer to the WEB address, <http://www.ul.com/japan/jpn/pages/services/emc/about/mark1/index.jsp#nvlap>

UL Japan, Inc.

Ise EMC Lab.

4383-326 Asama-cho, Ise-shi, Mie-ken 516-0021 JAPAN

Telephone : +81 596 24 8999

Facsimile : +81 596 24 8124

13-EM-F0429

CONTENTS	PAGE
SECTION 1: Customer information	4
SECTION 2: Equipment under test (E.U.T.)	4
SECTION 3: Test specification, procedures & results	6
SECTION 4: Operation of E.U.T. during testing	9
SECTION 5: Radiated Spurious Emission	12
SECTION 6: Antenna Terminal Conducted Tests	14
APPENDIX 1: Data of EMI test	15
6dB Bandwidth	15
Maximum Peak Output Power	18
Average Output Power	21
Radiated Spurious Emission	22
Band Edge confirmation	34
Conducted Spurious Emission	36
Power Density	37
99%Occupied Bandwidth	40
APPENDIX 2: Test instruments	42
APPENDIX 3: Photographs of test setup	44
Radiated Spurious Emission	44
Worst Case Position	45

UL Japan, Inc.

Ise EMC Lab.

4383-326 Asama-cho, Ise-shi, Mie-ken 516-0021 JAPAN

Telephone : +81 596 24 8999

Facsimile : +81 596 24 8124

SECTION 1: Customer information

Company Name : MITSUBISHI ELECTRIC CORPORATION SANDA WORKS
Address : 2-3-33, Miwa, Sanda-city, Hyogo, 669-1513, Japan
Telephone Number : +81-79-559-3607
Facsimile Number : +81-79-559-3875
Contact Person : Yuji Funaba

SECTION 2: Equipment under test (E.U.T.)

2.1 Identification of E.U.T.

Type of Equipment : HEADUNIT A-HIGH
Model No. : NR-213
Serial No. : Refer to Clause 4.2
Rating : DC 12 V
Receipt Date of Sample : February 26, 2015
Country of Mass-production : Japan
Condition of EUT : Production prototype
(Not for Sale: This sample is equivalent to mass-produced items.)
Modification of EUT : No Modification by the test lab

UL Japan, Inc.

Ise EMC Lab.

4383-326 Asama-cho, Ise-shi, Mie-ken 516-0021 JAPAN

Telephone : +81 596 24 8999

Facsimile : +81 596 24 8124

2.2 Product Description

General Specification

Clock frequency(ies) in the system : 1.4 GHz,
40 MHz (Radio part)

Radio Specification

	IEEE802.11b	IEEE802.11g/n (20 M band)	IEEE802.11a/n (20 M band)	IEEE802.11n (40 M band)	Bluetooth Ver.3.0 with EDR function
Frequency of operation	2412-2462MHz *1)	2412-2462MHz *1)	5180-5240MHz 5260-5320MHz 5500-5700MHz 5745-5825MHz	5190-5230MHz 5270-5310MHz 5510-5670MHz 5755-5795MHz	2402-2480MHz
Type of modulation	DSSS (CCK, DQPSK, DBPSK)	OFDM-CCK (64QAM, 16QAM, QPSK, BPSK)	OFDM (64QAM, 16QAM, QPSK, BPSK)		FHSS (GFSK, $\pi/4$ -DQPSK, 8-DPSK)
Channel spacing	5MHz		20MHz	40MHz	1MHz
Antenna type	Printed patch Antenna				Dipole Pattern Antenna
Antenna Gain	3.3dBi		6.5dBi		2.32dBi
Antenna Connector type	FAKRA				PSE-LP2

*1) This test report applies for WLAN (IEEE802.11b/g/n-20 [2412-2462MHz]).

	GPS/GLONASS
Frequency of operation	GPS: 1575.42MHz GLONASS: 1597.55-1605.89MHz
Type of modulation	GPS: BPSK GLONASS: BPSK
Channel spacing	GLONASS: 0.5625MHz
Antenna type	Active antenna
Antenna Connector type	FAKRA
Antenna Gain	25dBi

UL Japan, Inc.

Ise EMC Lab.

4383-326 Asama-cho, Ise-shi, Mie-ken 516-0021 JAPAN

Telephone : +81 596 24 8999

Facsimile : +81 596 24 8124

SECTION 3: Test specification, procedures & results

3.1 Test Specification

Test Specification : FCC Part 15 Subpart C: 2015, final revised on January 21, 2015

Title : FCC 47CFR Part15 Radio Frequency Device Subpart C Intentional Radiators
Section 15.207 Conducted limits
Section 15.247 Operation within the bands 902-928MHz,
2400-2483.5MHz, and 5725-5850MHz

3.2 Procedures and results

Item	Test Procedure	Specification	Worst margin	Results	Remarks
Conducted Emission	FCC: ANSI C63.4-2009 7. AC powerline Conducted Emission measurements ----- IC: RSS-Gen 8.8	FCC: Section 15.207 ----- IC: RSS-Gen 8.8	N/A	N/A *1)	-
6dB Bandwidth	FCC: KDB 558074 D01 DTS Meas Guidance v03r03 ----- IC: -	FCC: Section 15.247(a)(2) ----- IC: RSS-247 5.2(1)	See data.	Complied	Conducted
Maximum Peak Output Power	FCC: KDB 558074 D01 DTS Meas Guidance v03r03 ----- IC: RSS-Gen 6.12	FCC: Section 15.247(b)(3) ----- IC: RSS-247 5.4(4)		Complied	Conducted
Power Density	FCC: KDB 558074 D01 DTS Meas Guidance v03r03 ----- IC: -	FCC: Section 15.247(e) ----- IC: RSS-247 5.2(2)		Complied	Conducted
Spurious Emission Restricted Band Edges	FCC: KDB 558074 D01 DTS Meas Guidance v03r03 ----- IC: RSS-Gen 6.13	FCC: Section15.247(d) ----- IC: RSS-247 5.5 RSS-Gen 8.9 RSS-Gen 8.10	1.6dB 1838.017MHz, AV, Vertical 1837.880MHz, AV, Vertical	Complied	Conducted (below 30 MHz)/ Radiated (above 30 MHz) *2)

Note: UL Japan, Inc.'s EMI Work Procedures No. 13-EM-W0420 and 13-EM-W0422.
*1) The test is not applicable since the EUT is not the device that is designed to be connected to the public utility (AC) power line.
*2) Radiated test was selected over 30 MHz based on section 15.247(d) and KDB 558074 D01 DTS Meas Guidance v03r03 12.2.7.

* In case any questions arise about test procedure, ANSI C63.4: 2009 is also referred.

FCC 15.31 (e)

The EUT provides stable voltage (DC 3.3 V) constantly to the wireless transmitter regardless of input voltage. Instead of a new battery, DC power supply was used for the test. That does not affect the test result, therefore the EUT complies with the requirement.

FCC Part 15.203 Antenna requirement

It is impossible for end users to replace the antenna, because the antenna is mounted inside of the vehicle. Therefore, the equipment complies with the antenna requirement of Section 15.203.

UL Japan, Inc.

Ise EMC Lab.

4383-326 Asama-cho, Ise-shi, Mie-ken 516-0021 JAPAN

Telephone : +81 596 24 8999

Facsimile : +81 596 24 8124

3.3 Addition to standard

Item	Test Procedure	Specification	Worst margin	Results	Remarks
99% Occupied Bandwidth	IC: RSS-Gen 6.6	IC: -	N/A	-	Conducted
Co-location & Co-operation (Confirmation testing for Radiated Spurious Emission at simultaneous transmission)	FCC: KDB 558074 D01 DTS Meas Guidance v03r03 IC: RSS-Gen 6.13	FCC: Section15.247(d) IC: RSS-247 5.5	6.5 dB 1844.828 MHz, Vertical, AV	Complied	Radiated

Other than above, no addition, exclusion nor deviation has been made from the standard.

3.4 Uncertainty

EMI

The following uncertainties have been calculated to provide a confidence level of 95% using a coverage factor k=2.

Test room (semi-anechoic chamber)	Radiated emission						
	(3m*)(+dB)				(1m*)(+dB)		(0.5m*)(+dB)
	9kHz -30MHz	30MHz -300MHz	300MHz -1GHz	1GHz -10GHz	10GHz -18GHz	18GHz -26.5GHz	26.5GHz -40GHz
No.1	4.3dB	5.5dB	6.3dB	5.5dB	5.8dB	5.8dB	4.3dB
No.2	4.2dB	5.4dB	6.3dB	5.4dB	5.7dB	5.9dB	5.6dB
No.3	4.4dB	5.4dB	6.4dB	5.2dB	5.5dB	5.8dB	5.5dB
No.4	4.7dB	5.6dB	6.4dB	5.3dB	5.7dB	5.9dB	5.5dB

*3m/1m/0.5m = Measurement distance

Power meter (+dB)	
Below 1GHz	Above 1GHz
0.7dB	1.5dB

Antenna terminal conducted emission and Power density (+dB)			Antenna terminal conducted emission (+dB)		Channel power (+dB)
Below 1GHz	1GHz-3GHz	3GHz-18GHz	18GHz-26.5GHz	26.5GHz-40GHz	
1.5dB	1.7dB	2.8dB	2.8dB	2.9dB	2.6dB

Radiated emission test(3m)

The data listed in this report meets the limits unless the uncertainty is taken into consideration.

UL Japan, Inc.

Ise EMC Lab.

4383-326 Asama-cho, Ise-shi, Mie-ken 516-0021 JAPAN

Telephone : +81 596 24 8999

Facsimile : +81 596 24 8124

3.5 Test Location

UL Japan, Inc. Ise EMC Lab. *NVLAP Lab. code: 200572-0
4383-326 Asama-cho, Ise-shi, Mie-ken 516-0021 JAPAN
Telephone : +81 596 24 8999 Facsimile : +81 596 24 8124

	IC Registration Number	Width x Depth x Height (m)	Size of reference ground plane (m) / horizontal conducting plane	Other rooms
No.1 semi-anechoic chamber	2973C-1	19.2 x 11.2 x 7.7m	7.0 x 6.0m	No.1 Power source room
No.2 semi-anechoic chamber	2973C-2	7.5 x 5.8 x 5.2m	4.0 x 4.0m	-
No.3 semi-anechoic chamber	2973C-3	12.0 x 8.5 x 5.9m	6.8 x 5.75m	No.3 Preparation room
No.3 shielded room	-	4.0 x 6.0 x 2.7m	N/A	-
No.4 semi-anechoic chamber	2973C-4	12.0 x 8.5 x 5.9m	6.8 x 5.75m	No.4 Preparation room
No.4 shielded room	-	4.0 x 6.0 x 2.7m	N/A	-
No.5 semi-anechoic chamber	-	6.0 x 6.0 x 3.9m	6.0 x 6.0m	-
No.6 shielded room	-	4.0 x 4.5 x 2.7m	4.0 x 4.5 m	-
No.6 measurement room	-	4.75 x 5.4 x 3.0m	4.75 x 4.15 m	-
No.7 shielded room	-	4.7 x 7.5 x 2.7m	4.7 x 7.5m	-
No.8 measurement room	-	3.1 x 5.0 x 2.7m	N/A	-
No.9 measurement room	-	8.0 x 4.6 x 2.8m	2.4 x 2.4m	-
No.11 measurement room	-	6.2 x 4.7 x 3.0m	4.8 x 4.6m	-

* Size of vertical conducting plane (for Conducted Emission test) : 2.0 x 2.0m for No.1, No.2, No.3, and No.4 semi-anechoic chambers and No.3 and No.4 shielded rooms.

3.6 Data of EMI, Test instruments, and Test set up

Refer to APPENDIX.

UL Japan, Inc. Ise EMC Lab.

4383-326 Asama-cho, Ise-shi, Mie-ken 516-0021 JAPAN
Telephone : +81 596 24 8999
Facsimile : +81 596 24 8124

SECTION 4: Operation of E.U.T. during testing

4.1 Operating Mode(s)

Test operating mode was determined as follows according to “Section 1 of 6 802.11 a/b/g/n testing - Managing Complex Regulatory Approvals - ” of TCB Council Workshop October 2009.

Mode	Remarks*
IEEE 802.11b (11b)	5.5Mbps, PN9
IEEE 802.11g (11g)	18Mbps, PN9
IEEE 802.11n 20MHz BW (11n-20)	MCS 0, PN9
*The worst condition was determined based on the test result of Maximum Peak Output Power (Mid Channel)	
*Power of the EUT was set by the software as follows; - Power Setting: default - Software: Engineering mode E45.2 *This setting of software is the worst case. Any conditions under the normal use do not exceed the condition of setting. In addition, end users cannot change the settings of the output power of the product.	

<2.4GHz band>

*The details of Operating mode(s)

Test Item	Operating Mode	Tested frequency
Radiated Spurious Emission (Below 1GHz)	11n-20 Tx *1)	2412 MHz *1)
Radiated Spurious Emission (Above 1GHz)	11b Tx 11n-20 Tx *2)	2412 MHz 2437 MHz 2462 MHz
Conducted Spurious Emission	11n-20 Tx *1)	2412 MHz *1)
6dB Bandwidth, Maximum Peak Output Power, Average Output Power, Power Density, 99% Occupied Bandwidth	11b Tx 11g Tx 11n-20 Tx	2412 MHz 2437 MHz 2462 MHz
Radiated Spurious Emission (Co location transmitting) *3)	11n-20 Tx + 11a Tx	2412 MHz + 5180 MHz 2462 MHz + 5180 MHz

*1) The operating mode and tested frequency were tested as a representative, because it had the highest power at antenna terminal test.

*2) Since 11g and 11n-20 have the same modulation method and no differences in transmitting specification, test was performed on the representative mode that had the highest peak output power.

*3) The combination of 2.4 GHz band maximum power and 5 GHz band maximum power was tested in case using the same antenna. For another combination, refer 5 GHz band test report (10607274H-C-R1).

UL Japan, Inc.

Ise EMC Lab.

4383-326 Asama-cho, Ise-shi, Mie-ken 516-0021 JAPAN

Telephone : +81 596 24 8999

Facsimile : +81 596 24 8124

4.2 Configuration and peripherals

[Radiated Spurious Emission test]

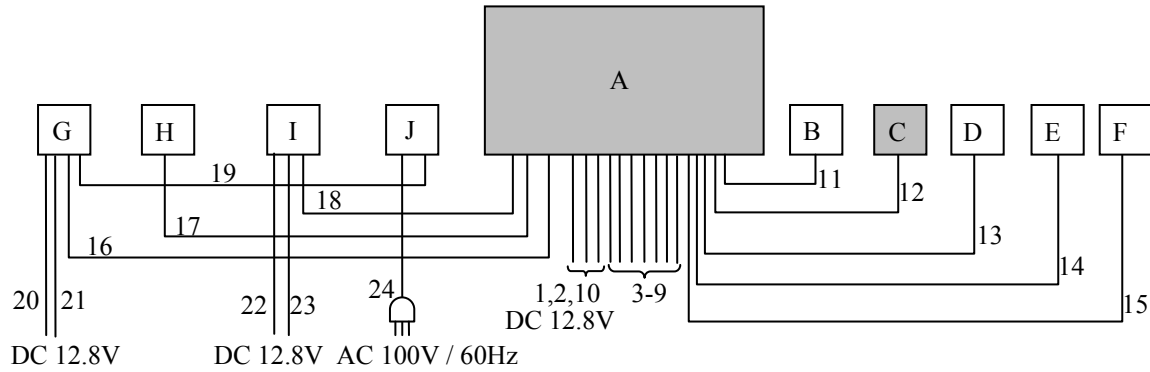

[Antenna Terminal Conducted tests]

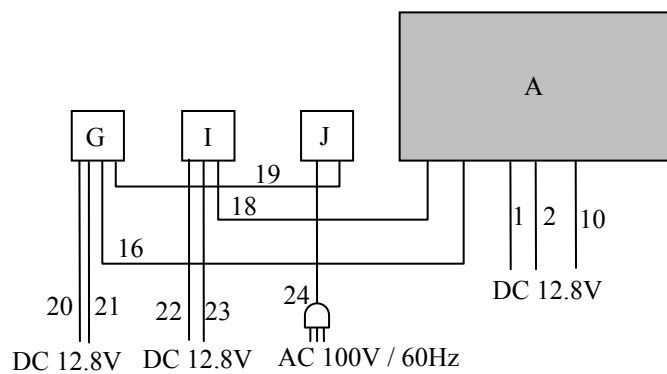

* Cabling and setup(s) were taken into consideration and test data was taken under worse case conditions.

* The testing was performed with DC 12.8 V only.

The voltage which the car battery mounted in the car outputs was selected as a test voltage according to the customer's request.

As the stable voltage (DC 3.3 V) is provided to RF module via the internal regulator, it does not influence on the test result.

UL Japan, Inc.

Ise EMC Lab.

4383-326 Asama-cho, Ise-shi, Mie-ken 516-0021 JAPAN

Telephone : +81 596 24 8999

Facsimile : +81 596 24 8124

Description of EUT and Support equipment

No.	Item	Model number	Serial number	Manufacturer	Remarks
A	HEADUNIT A-HIGH	NR-213	No 3-2 for RE* No 3-1 for AT*	mitsubishi electric corporation sanda works	EUT
B	BT Antenna	050 978-A	38113	WiSi	-
C	WLAN Antenna	A2139058402	1234 00012	WiSi	EUT
D	GPS Antenna	-	-	mitsubishi electric corporation sanda works	-
E	USB Memory	RFU-2	120301	BUFFALO	-
F	Dummy Load	-	-	mitsubishi electric corporation sanda works	-
G	HSVL PCB	NTG 5.5 H0H	489	mitsubishi electric corporation sanda works	-
H	HSVL PCB	NTG 5.5 H0H	487	mitsubishi electric corporation sanda works	-
I	Controller	A 166 900 10 10	63358850202	Mercedes-Benz	-
J	LCD Monitor	EW2730-B	ETNAB07468S L0	BenQ	-

* RE: Radiated Spurious Emission test / AT: Antenna Terminal Conducted tests

List of cables used

No.	Name	Length (m)	Shield		Remarks
			Cable	Connector	
1	DC Cable (+)	2.0	Unshielded	Unshielded	-
2	DC Cable (-)	2.0	Unshielded	Unshielded	-
3	Dummy Cable (Aux)	1.0	Shielded	Shielded	-
4	Dummy Cable (RUG)	1.0	Shielded	Shielded	-
5	Dummy Cable (Tune 1)	1.0	Shielded	Shielded	-
6	Dummy Cable (Tune 2)	1.0	Shielded	Shielded	-
7	Dummy Cable (Tune 3)	1.0	Shielded	Shielded	-
8	USB Cable 1	1.0	Shielded	Shielded	-
9	USB Cable 2	1.0	Shielded	Shielded	-
10	Main Harness	1.0	Unshielded	Unshielded	-
11	BT Antenna Cable	0.5	Shielded	Shielded	-
12	WLAN Antenna Cable	1.5	Shielded	Shielded	-
13	GPS Antenna Cable	5.0	Shielded	Shielded	-
14	USB Cable 3	1.0	Shielded	Shielded	-
15	Speaker Cable	0.5	Unshielded	Unshielded	-
16	HSLV Cable	1.0	Shielded	Shielded	-
17	HSLV Cable	1.0	Shielded	Shielded	-
18	Controller Cable	2.3	Shielded	Shielded	-
19	DVI Cable	3.0	Shielded	Shielded	-
20	DC Cable (+)	2.0	Shielded	Shielded	-
21	DC Cable (-)	2.0	Unshielded	Unshielded	-
22	DC Cable (+)	2.0	Unshielded	Unshielded	-
23	DC Cable (-)	2.0	Unshielded	Unshielded	-
24	AC Cable	2.0	Unshielded	Unshielded	-

**UL Japan, Inc.
Ise EMC Lab.**

4383-326 Asama-cho, Ise-shi, Mie-ken 516-0021 JAPAN
Telephone : +81 596 24 8999
Facsimile : +81 596 24 8124

SECTION 5: Radiated Spurious Emission

Test Procedure

It was measured based on "11.0 Emissions in non-restricted frequency bands" of "558074 D01 DTS Meas Guidance v03r03".

EUT was placed on a urethane platform of nominal size, 1.0m by 2.0m, raised 0.8m above the conducting ground plane. The Radiated Electric Field Strength has been measured in a Semi Anechoic Chamber with a ground plane.

The height of the measuring antenna varied between 1 and 4m and EUT was rotated a full revolution in order to obtain the maximum value of the electric field strength.

The measurements were performed for both vertical and horizontal antenna polarization with the Test Receiver, or the Spectrum Analyzer.

The measurements were made with the following detector function of the test receiver and the Spectrum analyzer (in linear mode).

The test was made with the detector (RBW/VBW) in the following table.

When using Spectrum analyzer, the test was made with adjusting span to zero by using peak hold.

Test Antennas are used as below;

Frequency	30MHz to 300MHz	300MHz to 1GHz	Above 1GHz
Antenna Type	Biconical	Logperiodic	Horn

In any 100kHz bandwidth outside the restricted band in which the spread spectrum intentional radiator is operating, the radio frequency power that is produced by the intentional radiator confirmed 20dB below that in the 100kHz bandwidth within the band that contains the highest level of the desired power, based on a radiated measurement.

20dBc was applied to the frequency over the limit of FCC 15.209 / Table 4 of RSS-Gen 8.9(IC) and outside the restricted band of FCC15.205 / Table 6 of RSS-Gen 8.10 (IC).

Frequency	Below 1GHz	Above 1GHz		20dBc
Instrument used	Test Receiver	Spectrum Analyzer		Spectrum Analyzer
Detector	QP	PK	AV *1)	PK
IF Bandwidth	BW 120kHz	RBW: 1MHz VBW: 3MHz	Average Power Method: <u>12.2.5.1</u> RBW: 1 MHz VBW: 3 MHz Detector: Power Averaging (RMS) Trace: 100 traces	RBW: 100kHz VBW: 300kHz
Test Distance	3m	3m (below 10GHz), 1m *2) (above 10GHz)		3m (below 10GHz), 1m *2) (above 10GHz)

*1) Average Power Measurement was performed based on 6.0 & 12.2.5 of "KDB 558074 D01 DTS Meas Guidance v03r03"

*2) Distance Factor: $20 \times \log(3.0\text{m}/1.0\text{m}) = 9.5\text{dB}$

UL Japan, Inc.

Ise EMC Lab.

4383-326 Asama-cho, Ise-shi, Mie-ken 516-0021 JAPAN

Telephone : +81 596 24 8999

Facsimile : +81 596 24 8124

[WLAN antenna]

- The carrier level and noise levels were confirmed at each position of X, Y and Z axes of WLAN antenna to see the position of maximum noise, and the test was made at the position that has the maximum noise.

[HEADUNIT A-HIGH]

-The test was made on EUT at the normal use position.

The test results and limit are rounded off to one decimal place, so some differences might be observed.

Measurement range : 30M-26.5GHz
Test data : APPENDIX
Test result : Pass

UL Japan, Inc.

Ise EMC Lab.

4383-326 Asama-cho, Ise-shi, Mie-ken 516-0021 JAPAN

Telephone : +81 596 24 8999

Facsimile : +81 596 24 8124

SECTION 6: Antenna Terminal Conducted Tests

Test Procedure

The tests were made with below setting connected to the antenna port.

Test	Span	RBW	VBW	Sweep time	Detector	Trace	Instrument used
6dB Bandwidth	20MHz	100kHz	300kHz	Auto	Peak	Max Hold	Spectrum Analyzer
99% Occupied Bandwidth	Enough width to display emission skirts	1 to 5% of OBW	Three times of RBW	Auto	Peak	Max Hold*1)	Spectrum Analyzer
Maximum Peak Output Power	-	-	-	Auto	Peak/ Average *2)	-	Power Meter (Sensor: 50MHz BW)
Peak Power Density	1.5 times the 6dB Bandwidth	3kHz	10kHz	Auto	Peak	Max Hold	Spectrum Analyzer *3)
Conducted Spurious Emission *4)	9kHz to 150kHz	200Hz	620Hz	Auto	Peak	Max Hold	Spectrum Analyzer
	150kHz to 30MHz	9.1kHz	27kHz				
Band Edge confirmation	40 MHz	100 kHz	300 kHz	Auto	Peak	Max Hold	Spectrum Analyzer *2)

*1) The measurement was performed with Max Hold since the duty cycle was not 100%.

*2) Reference data

*3) Section 10.2 Method PKPSD (peak PSD) of "KDB 558074 D01 DTS Meas Guidance v03r03".

*4) In the frequency range below 30MHz, RBW was narrowed to separate the noise contents.

Then, wide-band noise near the limit was checked separately, however the noise was not detected as shown in the chart.(9kHz-150kHz:RBW=200Hz, 150kHz-30MHz:RBW=9.1kHz)

The test results and limit are rounded off to two decimals place, so some differences might be observed.

Test data : APPENDIX
Test result : Pass

UL Japan, Inc.

Ise EMC Lab.

4383-326 Asama-cho, Ise-shi, Mie-ken 516-0021 JAPAN

Telephone : +81 596 24 8999

Facsimile : +81 596 24 8124

APPENDIX 1: Data of EMI test

6dB Bandwidth

Test place Ise EMC Lab. No.11 Measurement Room
Report No. 10607274H
Date 03/04/2015
Temperature/ Humidity 22 deg. C / 32% RH
Engineer Tsubasa Takayama
Mode 11b Tx / 11g Tx / 11n-20 Tx

11b

Frequency [MHz]	6dB Bandwidth [MHz]	Limit [kHz]
2412	8.193	>500
2437	8.179	>500
2462	8.052	>500

11g

Frequency [MHz]	6dB Bandwidth [MHz]	Limit [kHz]
2412	15.355	>500
2437	15.376	>500
2462	15.356	>500

11n-20

Frequency [MHz]	6dB Bandwidth [MHz]	Limit [kHz]
2412	15.151	>500
2437	15.149	>500
2462	15.152	>500

6dB Bandwidth

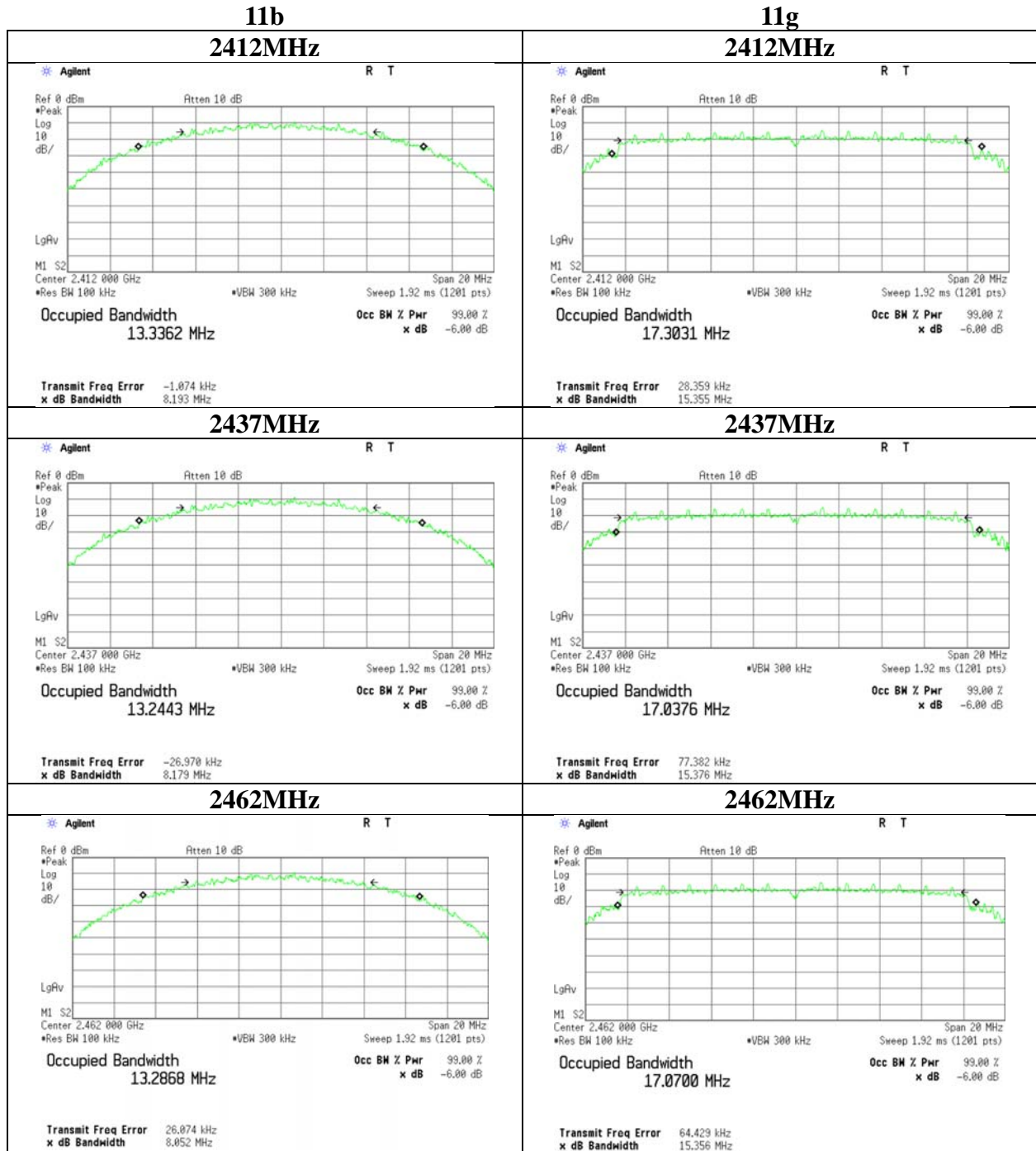

6dB Bandwidth

11n-20

2412MHz

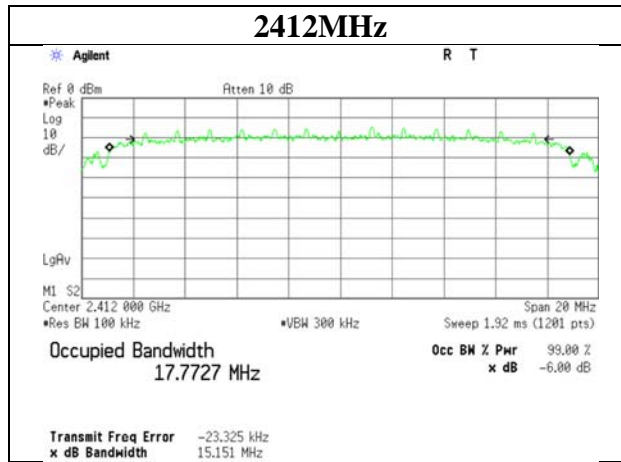

2437MHz

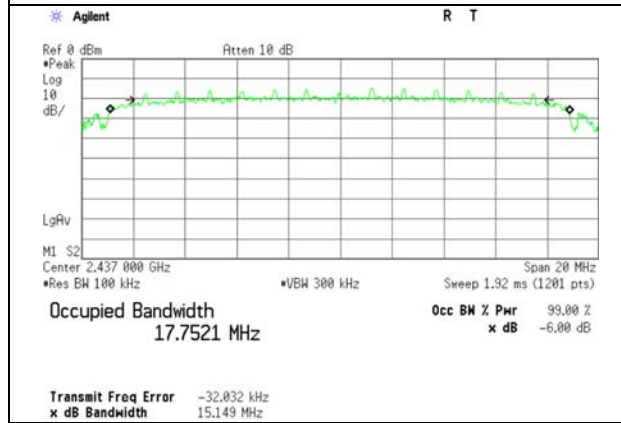

2462MHz

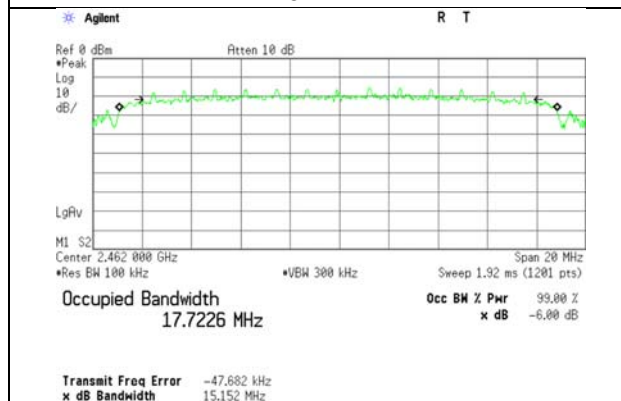

UL Japan, Inc.
Ise EMC Lab.

4383-326 Asama-cho, Ise-shi, Mie-ken 516-0021 JAPAN
 Telephone : +81 596 24 8999
 Facsimile : +81 596 24 8124

Maximum Peak Output Power

Test place	Ise EMC Lab. No.7 Measurement Room
Report No.	10607274H
Date	02/27/2015
Temperature/ Humidity	24 deg. C / 32% RH
Engineer	Tsubasa Takayama
Mode	11b Tx

Freq. [MHz]	Reading [dBm]	Cable Loss [dB]	Atten. [dB]	Result		Limit		Margin [dB]
				[dBm]	[mW]	[dBm]	[mW]	
2412	0.32	2.32	10.08	12.72	18.71	30.00	1000	17.28
2437	0.52	2.32	10.08	12.92	19.59	30.00	1000	17.08
2462	0.50	2.32	10.08	12.90	19.50	30.00	1000	17.10

Sample Calculation:

Result = Reading + Cable Loss (including Cable(s) Customer Supplied) + Attenuator

2437MHz

Rate [Mbps]	Reading [dBm]	Remark
1	0.48	
2	0.50	
5.5	0.52	*
11	0.32	

*: Worst Rate

All comparison were carried out on same frequency and measurement factors.

UL Japan, Inc.

Ise EMC Lab.

4383-326 Asama-cho, Ise-shi, Mie-ken 516-0021 JAPAN

Telephone : +81 596 24 8999

Facsimile : +81 596 24 8124

Maximum Peak Output Power

Test place	Ise EMC Lab. No.7 Measurement Room
Report No.	10607274H
Date	02/27/2015
Temperature/ Humidity	24 deg. C / 32% RH
Engineer	Tsubasa Takayama
Mode	11g Tx

Freq. [MHz]	Reading [dBm]	Cable Loss [dB]	Atten. [dB]	Result		Limit		Margin [dB]
				[dBm]	[mW]	[dBm]	[mW]	
2412	3.43	2.32	10.08	15.83	38.28	30.00	1000	14.17
2437	3.50	2.32	10.08	15.90	38.90	30.00	1000	14.10
2462	3.04	2.32	10.08	15.44	34.99	30.00	1000	14.56

Sample Calculation:

Result = Reading + Cable Loss (including Cable(s) Customer Supplied) + Attenuator

2437MHz

Rate [Mbps]	Reading [dBm]	Remark
6	2.62	
9	3.06	
12	3.13	
18	3.50	*
24	2.31	
36	2.50	
48	2.55	
54	2.13	

*: Worst Rate

All comparison were carried out on same frequency and measurement factors.

UL Japan, Inc.

Ise EMC Lab.

4383-326 Asama-cho, Ise-shi, Mie-ken 516-0021 JAPAN

Telephone : +81 596 24 8999

Facsimile : +81 596 24 8124

Maximum Peak Output Power

Test place	Ise EMC Lab. No.7 Measurement Room
Report No.	10607274H
Date	02/27/2015
Temperature/ Humidity	24 deg. C / 32% RH
Engineer	Tsubasa Takayama
Mode	11n-20 Tx

Freq. [MHz]	Reading [dBm]	Cable Loss [dB]	Atten. [dB]	Result		Limit		Margin [dB]
				[dBm]	[mW]	[dBm]	[mW]	
2412	3.86	2.32	10.08	16.26	42.27	30.00	1000	13.74
2437	3.52	2.32	10.08	15.92	39.08	30.00	1000	14.08
2462	3.43	2.32	10.08	15.83	38.28	30.00	1000	14.17

Sample Calculation:

Result = Reading + Cable Loss (including Cable(s) Customer Supplied) + Attenuator

2437MHz

Rate [MCS]	Reading [dBm]	Remark
0	3.52	*
1	3.16	
2	2.57	
3	1.96	
4	1.96	
5	2.65	
6	2.59	
7	2.54	

*: Worst Rate

All comparison were carried out on same frequency and measurement factors.

UL Japan, Inc.

Ise EMC Lab.

4383-326 Asama-cho, Ise-shi, Mie-ken 516-0021 JAPAN

Telephone : +81 596 24 8999

Facsimile : +81 596 24 8124

Average Output Power

Test place	Ise EMC Lab. No.7 Measurement Room
Report No.	10607274H
Date	02/27/2015
Temperature/ Humidity	24 deg. C / 32% RH
Engineer	Tsubasa Takayama
Mode	11b Tx / 11g Tx / 11n-20 Tx

[AV]

11b **5.5Mbps**

Freq. [MHz]	Reading [dBm]	Cable Loss [dB]	Atten. [dB]	Duty [dB]	Result	
					[dBm]	[mW]
2412	-12.26	2.32	10.08	9.95	10.09	10.21
2437	-11.84	2.32	10.08	9.95	10.51	11.25
2462	-11.75	2.32	10.08	9.95	10.60	11.48

11g **18Mbps**

Freq. [MHz]	Reading [dBm]	Cable Loss [dB]	Atten. [dB]	Duty [dB]	Result	
					[dBm]	[mW]
2412	-14.83	2.32	10.08	9.91	7.48	5.60
2437	-14.75	2.32	10.08	9.91	7.56	5.70
2462	-15.20	2.32	10.08	9.91	7.11	5.14

11n-20 **MCS0**

Freq. [MHz]	Reading [dBm]	Cable Loss [dB]	Atten. [dB]	Duty [dB]	Result	
					[dBm]	[mW]
2412	-15.16	2.32	10.08	9.95	7.19	5.24
2437	-15.38	2.32	10.08	9.95	6.97	4.98
2462	-15.42	2.32	10.08	9.95	6.93	4.93

Sample Calculation:

Result = Reading + Cable Loss (including Cable(s) Customer Supplied) + Duty + Attenuator

*Average output power result was calculated at 100% duty cycle using duty factor.

UL Japan, Inc.

Ise EMC Lab.

4383-326 Asama-cho, Ise-shi, Mie-ken 516-0021 JAPAN

Telephone : +81 596 24 8999

Facsimile : +81 596 24 8124

Radiated Spurious Emission

Test place	Ise EMC Lab. No.3 Semi Anechoic Chamber	
Report No.	10607274H	
Date	03/03/2015	03/04/2015
Temperature/ Humidity	23 deg. C / 37% RH	25deg. C / 39% RH
Engineer	Koji Yamamoto	Takafumi Noguchi
	(1-10GHz)	(10-26.5GHz)
Mode	11b Tx 2412MHz	

Polarity	Frequency [MHz]	Detector	Reading [dBuV]	Ant.Fac. [dB/m]	Loss [dB]	Gain [dB]	Result [dBuV/m]	Limit [dBuV/m]	Margin [dB]	Remark
Hori	1249.933	PK	59.5	24.7	2.4	34.6	52.0	73.9	21.9	
Hori	1838.017	PK	60.6	25.9	2.9	33.3	56.1	73.9	17.8	
Hori	2390.000	PK	43.1	26.8	3.2	32.7	40.4	73.9	33.5	
Hori	2499.882	PK	56.7	26.9	3.2	32.7	54.1	73.9	19.8	
Hori	3132.323	PK	49.4	27.5	3.6	32.4	48.1	73.9	25.8	
Hori	4824.000	PK	42.1	30.6	4.4	31.8	45.3	73.9	28.6	Floor Noise
Hori	7236.000	PK	42.5	35.9	5.6	32.7	51.3	73.9	22.6	Floor Noise
Hori	8195.625	PK	47.4	37.1	5.8	32.9	57.4	73.9	16.5	
Hori	9648.000	PK	41.6	38.5	6.4	33.4	53.1	73.9	20.8	Floor Noise
Hori	1249.933	AV	58.2	24.7	2.4	34.6	50.7	53.9	3.2	
Hori	1838.017	AV	50.1	25.9	2.9	33.3	45.6	53.9	8.3	
Hori	2390.000	AV	34.2	26.8	3.2	32.7	31.5	53.9	22.4	
Hori	2499.882	AV	54.4	26.9	3.2	32.7	51.8	53.9	2.1	
Hori	3132.323	AV	43.3	27.5	3.6	32.4	42.0	53.9	11.9	
Hori	4824.000	AV	31.9	30.6	4.4	31.8	35.1	53.9	18.8	Floor Noise
Hori	7236.000	AV	33.5	35.9	5.6	32.7	42.3	53.9	11.6	Floor Noise
Hori	8195.625	AV	35.5	37.1	5.8	32.9	45.5	53.9	8.4	
Hori	9648.000	AV	33.1	38.5	6.4	33.4	44.6	53.9	9.3	Floor Noise
Vert	1249.933	PK	54.3	24.7	2.4	34.6	46.8	73.9	27.1	
Vert	1838.017	PK	66.2	25.9	2.9	33.3	61.7	73.9	12.2	
Vert	2390.000	PK	42.2	26.8	3.2	32.7	39.5	73.9	34.4	
Vert	2499.882	PK	53.8	26.9	3.2	32.7	51.2	73.9	22.7	
Vert	3132.323	PK	52.0	27.5	3.6	32.4	50.7	73.9	23.2	
Vert	4824.000	PK	41.6	30.6	4.4	31.8	44.8	73.9	29.1	Floor Noise
Vert	7236.000	PK	42.6	35.9	5.6	32.7	51.4	73.9	22.5	Floor Noise
Vert	8195.625	PK	46.6	37.1	5.8	32.9	56.6	73.9	17.3	
Vert	9648.000	PK	42.7	38.5	6.4	33.4	54.2	73.9	19.7	Floor Noise
Vert	1249.933	AV	52.8	24.7	2.4	34.6	45.3	53.9	8.6	
Vert	1838.017	AV	56.3	25.9	2.9	33.3	51.8	53.9	2.1	
Vert	2390.000	AV	33.5	26.8	3.2	32.7	40.8	53.9	13.2	
Vert	2499.882	AV	51.2	26.9	3.2	32.7	48.6	53.9	5.3	
Vert	3132.323	AV	48.1	27.5	3.6	32.4	46.8	53.9	7.1	
Vert	4824.000	AV	32.2	30.6	4.4	31.8	35.4	53.9	18.5	Floor Noise
Vert	7236.000	AV	33.1	35.9	5.6	32.7	41.9	53.9	12.0	Floor Noise
Vert	8195.625	AV	36.0	37.1	5.8	32.9	46.0	53.9	7.9	
Vert	9648.000	AV	32.9	38.5	6.4	33.4	44.4	53.9	9.5	Floor Noise

Result = Reading + Ant Factor + Loss (Cable+Attenuator+Filter-Distance factor(above 10GHz)) - Gain(Amplifier)

*Other frequency noises omitted in this report were not seen or had enough margin (more than 20dB).

Distance factor: 10GHz-26.5GHz 20log(3.0m/1.0m)= 9.5dB

*Noises that had duty cycle synchronized with the fundamental frequency were not detected at the band-edge and harmonics frequencies.

20dBc Data Sheet

Polarity	Frequency [MHz]	Detector	Reading [dBuV]	Ant Factor [dB/m]	Loss [dB]	Gain [dB]	Result [dBuV/m]	Limit [dBuV/m]	Margin [dB]	Remark
Hori	2412.000	PK	89.3	26.8	3.2	32.7	86.6	-	-	Carrier
Hori	2400.000	PK	40.5	26.8	3.2	32.7	37.8	66.6	28.8	
Vert	2412.000	PK	88.3	26.8	3.2	32.7	85.6	-	-	Carrier
Vert	2400.000	PK	39.5	26.8	3.2	32.7	36.8	65.6	28.8	

Result = Reading + Ant Factor + Loss (Cable+Attenuator+Filter-Distance factor(above 10GHz)) - Gain(Amplifier)

UL Japan, Inc.
Ise EMC Lab.

4383-326 Asama-cho, Ise-shi, Mie-ken 516-0021 JAPAN

Telephone : +81 596 24 8999

Facsimile : +81 596 24 8124

Radiated Spurious Emission

Test place Ise EMC Lab. No.3 Semi Anechoic Chamber
Report No. 10607274H
Date 03/03/2015 03/04/2015
Temperature/ Humidity 23 deg. C / 37% RH 25deg. C / 39% RH
Engineer Koji Yamamoto Takafumi Noguchi
(1-10GHz) (10-26.5GHz)
Mode 11b Tx 2462MHz

Polarity	Frequency [MHz]	Detector	Reading [dBuV]	Ant.Fac. [dB/m]	Loss [dB]	Gain [dB]	Result [dBuV/m]	Limit [dBuV/m]	Margin [dB]	Remark
Hori	1249.933	PK	57.9	24.7	2.4	34.6	50.4	73.9	23.5	
Hori	1838.017	PK	57.3	25.9	2.9	33.3	52.8	73.9	21.1	
Hori	2483.500	PK	43.8	26.9	3.2	32.7	41.2	73.9	32.7	
Hori	2499.882	PK	53.5	26.9	3.2	32.7	50.9	73.9	23.0	
Hori	3132.323	PK	48.6	27.5	3.6	32.4	47.3	73.9	26.6	
Hori	4924.000	PK	42.7	30.8	4.4	31.7	46.2	73.9	27.7	Floor Noise
Hori	7386.000	PK	42.8	35.9	5.6	32.7	51.6	73.9	22.3	Floor Noise
Hori	8195.625	PK	46.9	37.1	5.8	32.9	56.9	73.9	17.0	
Hori	9848.000	PK	43.1	38.8	6.5	33.5	54.9	73.9	19.0	Floor Noise
Hori	1249.933	AV	53.8	24.7	2.4	34.6	46.3	53.9	7.6	
Hori	1838.017	AV	46.6	25.9	2.9	33.3	42.1	53.9	11.8	
Hori	2483.500	AV	33.3	26.9	3.2	32.7	30.7	53.9	23.2	
Hori	2499.882	AV	50.8	26.9	3.2	32.7	48.2	53.9	5.7	
Hori	3132.323	AV	44.1	27.5	3.6	32.4	42.8	53.9	11.1	
Hori	4924.000	AV	32.1	30.8	4.4	31.7	35.6	53.9	18.3	Floor Noise
Hori	7386.000	AV	33.2	35.9	5.6	32.7	42.0	53.9	11.9	Floor Noise
Hori	8195.625	AV	36.3	37.1	5.8	32.9	46.3	53.9	7.6	
Hori	9848.000	AV	33.4	38.8	6.5	33.5	45.2	53.9	8.7	Floor Noise
Vert	1249.933	PK	53.6	24.7	2.4	34.6	46.1	73.9	27.8	
Vert	1838.017	PK	63.3	25.9	2.9	33.3	58.8	73.9	15.1	
Vert	2483.500	PK	45.8	26.9	3.2	32.7	43.2	73.9	30.7	
Vert	2499.882	PK	54.9	26.9	3.2	32.7	52.3	73.9	21.6	
Vert	3132.323	PK	49.8	27.5	3.6	32.4	48.5	73.9	25.4	
Vert	4924.000	PK	42.1	30.8	4.4	31.7	45.6	73.9	28.3	Floor Noise
Vert	7386.000	PK	43.6	35.9	5.6	32.7	52.4	73.9	21.5	Floor Noise
Vert	8195.625	PK	47.0	37.1	5.8	32.9	57.0	73.9	16.9	
Vert	9848.000	PK	42.3	38.8	6.5	33.5	54.1	73.9	19.8	Floor Noise
Vert	1249.933	AV	50.6	24.7	2.4	34.6	43.1	53.9	10.8	
Vert	1838.017	AV	54.5	25.9	2.9	33.3	50.0	53.9	3.9	
Vert	2483.500	AV	33.7	26.9	3.2	32.7	31.1	53.9	22.8	
Vert	2499.882	AV	50.2	26.9	3.2	32.7	47.6	53.9	6.3	
Vert	3132.323	AV	46.7	27.5	3.6	32.4	45.4	53.9	8.5	
Vert	4924.000	AV	32.6	30.8	4.4	31.7	36.1	53.9	17.8	Floor Noise
Vert	7386.000	AV	33.5	35.9	5.6	32.7	42.3	53.9	11.6	Floor Noise
Vert	8195.625	AV	38.1	37.1	5.8	32.9	48.1	53.9	5.8	
Vert	9848.000	AV	33.3	38.8	6.5	33.5	45.1	53.9	8.8	Floor Noise

Result = Reading + Ant Factor + Loss (Cable+Attenuator+Filter-Distance factor(above 10GHz)) - Gain(Amplifier)

*Other frequency noises omitted in this report were not seen or had enough margin (more than 20dB).

Distance factor: 10GHz-26.5GHz 20log(3.0m/1.0m)= 9.5dB

*Noises that had duty cycle synchronized with the fundamental frequency were not detected at the band-edge and harmonics frequencies.

UL Japan, Inc.

Ise EMC Lab.

4383-326 Asama-cho, Ise-shi, Mie-ken 516-0021 JAPAN

Telephone : +81 596 24 8999

Facsimile : +81 596 24 8124

Radiated Spurious Emission

Test place Ise EMC Lab. No.3 Semi Anechoic Chamber
Report No. 10607274H
Date 03/03/2015 03/04/2015 03/09/2015
Temperature/ Humidity 23 deg. C / 37% RH 25deg. C / 39% RH 25deg. C / 34% RH
Engineer Koji Yamamoto Takafumi Noguchi Tsubasa Takayama
(1-10GHz) (10-26.5GHz) (below 1GHz)
Mode 11n-20 Tx 2412MHz

Polarity	Frequency [MHz]	Detector	Reading [dBuV]	Ant.Fac. [dB/m]	Loss [dB]	Gain [dB]	Result [dBuV/m]	Limit [dBuV/m]	Margin [dB]	Remark
Hori	78.150	QP	35.3	6.3	7.8	32.1	17.3	40.0	22.7	
Hori	243.749	QP	35.8	17.1	9.4	32.0	30.3	46.0	15.7	
Hori	341.243	QP	34.3	16.0	10.2	31.9	28.6	46.0	17.4	
Hori	374.976	QP	33.9	16.9	10.4	31.9	29.3	46.0	16.7	
Hori	627.167	QP	33.7	19.7	12.0	32.0	33.4	46.0	12.6	
Hori	983.016	QP	41.2	23.3	13.6	30.5	47.6	53.9	6.3	
Hori	1250.000	PK	57.8	24.7	2.4	34.6	50.3	73.9	23.6	
Hori	1837.880	PK	59.6	25.9	2.9	33.3	55.1	73.9	18.8	
Hori	2390.000	PK	43.5	26.8	3.2	32.7	40.8	73.9	33.1	
Hori	2499.882	PK	54.5	26.9	3.2	32.7	51.9	73.9	22.0	
Hori	3132.323	PK	47.5	27.5	3.6	32.4	46.2	73.9	27.7	
Hori	4824.000	PK	42.1	30.8	4.4	31.7	45.6	73.9	28.3	Floor Noise
Hori	7236.000	PK	41.5	35.9	5.6	32.7	50.3	73.9	23.6	Floor Noise
Hori	8195.917	PK	48.2	37.1	5.8	32.9	58.2	73.9	15.7	
Hori	9648.000	PK	43.3	38.8	6.5	33.5	55.1	73.9	18.8	Floor Noise
Hori	1250.000	AV	55.9	24.7	2.4	34.6	48.4	53.9	5.5	
Hori	1837.880	AV	52.1	25.9	2.9	33.3	47.6	53.9	6.3	
Hori	2390.000	AV	34.6	26.8	3.2	32.7	31.9	53.9	22.0	
Hori	2499.882	AV	50.0	26.9	3.2	32.7	47.4	53.9	6.5	
Hori	3132.323	AV	42.9	27.5	3.6	32.4	41.6	53.9	12.3	
Hori	4824.000	AV	32.5	30.8	4.4	31.7	36.0	53.9	17.9	Floor Noise
Hori	7236.000	AV	32.7	35.9	5.6	32.7	41.5	53.9	12.4	Floor Noise
Hori	8195.917	AV	37.1	37.1	5.8	32.9	47.1	53.9	6.8	
Hori	9648.000	AV	33.2	38.8	6.5	33.5	45.0	53.9	8.9	Floor Noise
Vert	78.600	QP	39.6	6.3	7.8	32.1	21.6	40.0	18.4	
Vert	108.000	QP	35.6	11.3	8.1	32.1	22.9	43.5	20.6	
Vert	146.100	QP	36.4	14.7	8.6	32.1	27.6	43.5	15.9	
Vert	243.749	QP	36.4	17.1	9.4	32.0	30.9	46.0	15.1	
Vert	276.000	QP	33.0	18.6	9.8	31.9	29.5	46.0	16.5	
Vert	341.263	QP	32.9	16.0	10.2	31.9	27.2	46.0	18.8	
Vert	375.000	QP	31.2	16.9	10.4	31.9	26.6	46.0	19.4	
Vert	627.177	QP	31.0	19.7	12.0	32.0	30.7	46.0	15.3	
Vert	983.016	QP	38.0	23.3	13.6	30.5	44.4	53.9	9.5	
Vert	1250.000	PK	55.9	24.7	2.4	34.6	48.4	73.9	25.5	
Vert	1837.880	PK	65.9	25.9	2.9	33.3	61.4	73.9	12.5	
Vert	2390.000	PK	42.6	26.8	3.2	32.7	39.9	73.9	34.0	
Vert	2499.882	PK	53.5	26.9	3.2	32.7	50.9	73.9	23.0	
Vert	3132.323	PK	50.8	27.5	3.6	32.4	49.5	73.9	24.4	
Vert	4824.000	PK	42.7	30.8	4.4	31.7	46.2	73.9	27.7	Floor Noise
Vert	7236.000	PK	42.8	35.9	5.6	32.7	51.6	73.9	22.3	Floor Noise
Vert	8195.110	PK	48.2	37.1	5.8	32.9	58.2	73.9	15.7	
Vert	9648.000	PK	42.1	38.8	6.5	33.5	53.9	73.9	20.0	Floor Noise
Vert	1250.000	AV	54.0	24.7	2.4	34.6	46.5	53.9	7.4	
Vert	1837.880	AV	56.5	25.9	2.9	33.3	52.0	53.9	1.9	
Vert	2390.000	AV	33.5	26.8	3.2	32.7	30.8	53.9	23.1	
Vert	2499.882	AV	49.7	26.9	3.2	32.7	47.1	53.9	6.8	
Vert	3132.323	AV	45.8	27.5	3.6	32.4	44.5	53.9	9.4	
Vert	4824.000	AV	33.0	30.8	4.4	31.7	36.5	53.9	17.4	Floor Noise
Vert	7236.000	AV	33.1	35.9	5.6	32.7	41.9	53.9	12.0	Floor Noise
Vert	8195.110	AV	39.3	37.1	5.8	32.9	49.3	53.9	4.6	
Vert	9648.000	AV	33.8	38.8	6.5	33.5	45.6	53.9	8.3	Floor Noise

Result = Reading + Ant Factor + Loss (Cable+Attenuator+Filter-Distance factor(above 10GHz)) - Gain(Amplifier)

*Other frequency noises omitted in this report were not seen or had enough margin (more than 20dB).

Distance factor: 10GHz-26.5GHz 20log(3.0m/1.0m)= 9.5dB

*Noises that had duty cycle synchronized with the fundamental frequency were not detected at the band-edge and harmonics frequencies.

UL Japan, Inc.

Ise EMC Lab.

4383-326 Asama-cho, Ise-shi, Mie-ken 516-0021 JAPAN

Telephone : +81 596 24 8999

Facsimile : +81 596 24 8124

Radiated Spurious Emission
(Plot data, Worst case)

Test place	Ise EMC Lab. No.3 Semi Anechoic Chamber		
Report No.	10607274H		
Date	03/03/2015	03/04/2015	03/09/2015
Temperature/ Humidity	23 deg. C / 37% RH	25deg. C / 39% RH	25deg. C / 34% RH
Engineer	Koji Yamamoto	Takafumi Noguchi	Tsubasa Takayama
	(1-10GHz)	(10-26.5GHz)	(below 1GHz)
Mode	11n-20 Tx 2412MHz		

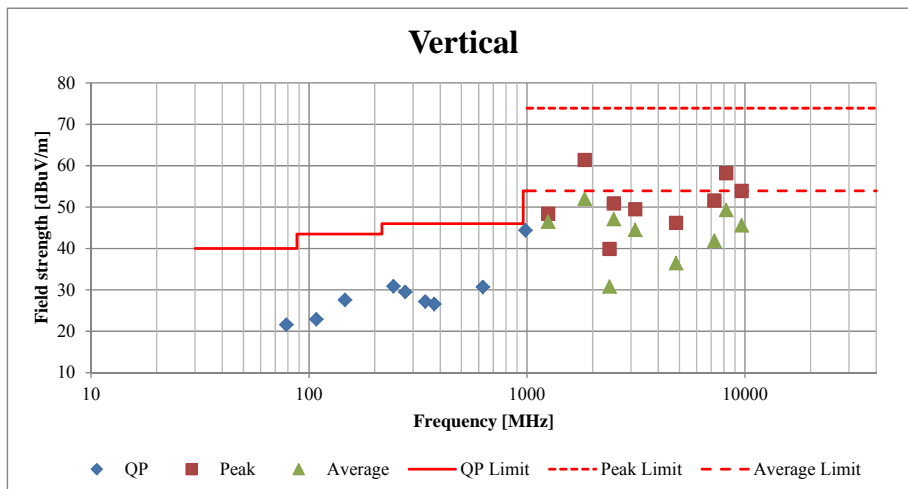
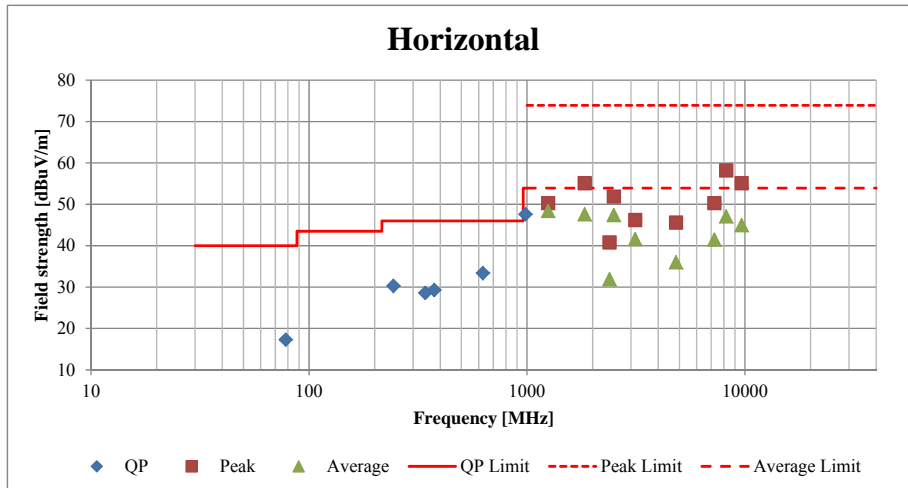

UL Japan, Inc.
Ise EMC Lab.

4383-326 Asama-cho, Ise-shi, Mie-ken 516-0021 JAPAN
 Telephone : +81 596 24 8999
 Facsimile : +81 596 24 8124

Radiated Spurious Emission

Test place : Ise EMC Lab. No.3 Semi Anechoic Chamber
 Report No. : 10607274H
 Date : 03/03/2015
 Temperature/ Humidity : 23 deg. C / 37% RH
 Engineer : Koji Yamamoto
 (1-10GHz)
 Mode : 11n-20 Tx 2412MHz

20dBc Data Sheet

Polarity	Frequency [MHz]	Detector	Reading [dBuV]	Ant Factor [dB/m]	Loss [dB]	Gain [dB]	Result [dBuV/m]	Limit [dBuV/m]	Margin [dB]	Remark
Hori	2412.000	PK	88.0	26.8	3.2	32.7	85.3	-	-	Carrier
Hori	2400.000	PK	46.8	26.8	3.2	32.7	44.1	65.3	21.2	
Vert	2412.000	PK	86.7	26.8	3.2	32.7	84.0	-	-	Carrier
Vert	2400.000	PK	45.6	26.8	3.2	32.7	42.9	64.0	21.1	

Result = Reading + Ant Factor + Loss (Cable+Attenuator+Filter-Distance factor(above 10GHz)) - Gain(Amplifier)

UL Japan, Inc.

Ise EMC Lab.

4383-326 Asama-cho, Ise-shi, Mie-ken 516-0021 JAPAN

Telephone : +81 596 24 8999

Facsimile : +81 596 24 8124

Radiated Spurious Emission

Test place	Ise EMC Lab. No.3 Semi Anechoic Chamber	
Report No.	10607274H	
Date	03/03/2015	03/04/2015
Temperature/ Humidity	23 deg. C / 37% RH	25deg. C / 39% RH
Engineer	Koji Yamamoto	Takafumi Noguchi
	(1-10GHz)	(10-26.5GHz)
Mode	11n-20 Tx 2437MHz	

Polarity	Frequency [MHz]	Detector	Reading [dBuV]	Ant.Fac. [dB/m]	Loss [dB]	Gain [dB]	Result [dBuV/m]	Limit [dBuV/m]	Margin [dB]	Remark
Hori	1250.000	PK	56.8	24.7	2.4	34.6	49.3	73.9	24.6	
Hori	1837.880	PK	58.9	25.9	2.9	33.3	54.4	73.9	19.5	
Hori	2499.882	PK	55.2	26.9	3.2	32.7	52.6	73.9	21.3	
Hori	3132.323	PK	48.8	27.5	3.6	32.4	47.5	73.9	26.4	
Hori	4874.000	PK	41.6	30.7	4.4	31.7	45.0	73.9	28.9	Floor Noise
Hori	7311.000	PK	42.5	35.9	5.6	32.7	51.3	73.9	22.6	Floor Noise
Hori	8195.917	PK	47.8	37.1	5.8	32.9	57.8	73.9	16.1	
Hori	9748.000	PK	42.9	38.7	6.5	33.4	54.7	73.9	19.2	Floor Noise
Hori	1250.000	AV	56.1	24.7	2.4	34.6	48.6	53.9	5.3	
Hori	1837.880	AV	52.5	25.9	2.9	33.3	48.0	53.9	5.9	
Hori	2499.882	AV	50.5	26.9	3.2	32.7	47.9	53.9	6.0	
Hori	3132.323	AV	43.8	27.5	3.6	32.4	42.5	53.9	11.4	
Hori	4874.000	AV	32.3	30.7	4.4	31.7	35.7	53.9	18.2	Floor Noise
Hori	7311.000	AV	33.0	35.9	5.6	32.7	41.8	53.9	12.1	Floor Noise
Hori	8195.917	AV	38.2	37.1	5.8	32.9	48.2	53.9	5.7	
Hori	9748.000	AV	33.1	38.7	6.5	33.4	44.9	53.9	9.0	Floor Noise
Vert	1250.000	PK	54.7	24.7	2.4	34.6	47.2	73.9	26.7	
Vert	1837.880	PK	66.1	25.9	2.9	33.3	61.6	73.9	12.3	
Vert	2499.882	PK	53.8	26.9	3.2	32.7	51.2	73.9	22.7	
Vert	3132.323	PK	52.1	27.5	3.6	32.4	50.8	73.9	23.1	
Vert	4874.000	PK	43.3	30.7	4.4	31.7	46.7	73.9	27.2	Floor Noise
Vert	7311.000	PK	42.1	35.9	5.6	32.7	50.9	73.9	23.0	Floor Noise
Vert	8195.110	PK	47.6	37.1	5.8	32.9	57.6	73.9	16.3	
Vert	9748.000	PK	42.3	38.7	6.5	33.4	54.1	73.9	19.8	Floor Noise
Vert	1250.000	AV	53.3	24.7	2.4	34.6	45.8	53.9	8.1	
Vert	1837.880	AV	56.8	25.9	2.9	33.3	52.3	53.9	1.6	
Vert	2499.882	AV	49.6	26.9	3.2	32.7	47.0	53.9	6.9	
Vert	3132.323	AV	46.3	27.5	3.6	32.4	45.0	53.9	8.9	
Vert	4874.000	AV	32.7	30.7	4.4	31.7	36.1	53.9	17.8	Floor Noise
Vert	7311.000	AV	33.1	35.9	5.6	32.7	41.9	53.9	12.0	Floor Noise
Vert	8195.110	AV	38.1	37.1	5.8	32.9	48.1	53.9	5.8	
Vert	9748.000	AV	33.1	38.7	6.5	33.4	44.9	53.9	9.0	Floor Noise

Result = Reading + Ant Factor + Loss (Cable+Attenuator+Filter-Distance factor(above 10GHz)) - Gain(Amplifier)

*Other frequency noises omitted in this report were not seen or had enough margin (more than 20dB).

Distance factor: 10GHz-26.5GHz 20log(3.0m/1.0m)= 9.5dB

*Noises that had duty cycle synchronized with the fundamental frequency were not detected at the band-edge and harmonics frequencies.

UL Japan, Inc.

Ise EMC Lab.

4383-326 Asama-cho, Ise-shi, Mie-ken 516-0021 JAPAN

Telephone : +81 596 24 8999

Facsimile : +81 596 24 8124

Radiated Spurious Emission

Test place Ise EMC Lab. No.3 Semi Anechoic Chamber
Report No. 10607274H
Date 03/03/2015 03/04/2015
Temperature/ Humidity 23 deg. C / 37% RH 25deg. C / 39% RH
Engineer Koji Yamamoto Takafumi Noguchi
(1-10GHz) (10-26.5GHz)
Mode 11n-20 Tx 2462MHz

Polarity	Frequency [MHz]	Detector	Reading [dBuV]	Ant.Fac. [dB/m]	Loss [dB]	Gain [dB]	Result [dBuV/m]	Limit [dBuV/m]	Margin [dB]	Remark
Hori	1250.000	PK	57.0	24.7	2.4	34.6	49.5	73.9	24.4	
Hori	1837.880	PK	59.1	25.9	2.9	33.3	54.6	73.9	19.3	
Hori	2483.500	PK	43.8	26.9	3.2	32.7	41.2	73.9	32.7	
Hori	2499.882	PK	54.1	26.9	3.2	32.7	51.5	73.9	22.4	
Hori	3132.323	PK	48.9	27.5	3.6	32.4	47.6	73.9	26.3	
Hori	4924.000	PK	42.4	30.8	4.4	31.7	45.9	73.9	28.0	Floor Noise
Hori	7386.000	PK	42.9	35.9	5.6	32.7	51.7	73.9	22.2	Floor Noise
Hori	8195.917	PK	48.3	37.1	5.8	32.9	58.3	73.9	15.6	
Hori	9848.000	PK	43.7	38.8	6.5	33.5	55.5	73.9	18.4	Floor Noise
Hori	1250.000	AV	55.3	24.7	2.4	34.6	47.8	53.9	6.1	
Hori	1837.880	AV	51.7	25.9	2.9	33.3	47.2	53.9	6.7	
Hori	2483.500	AV	33.4	26.9	3.2	32.7	30.8	53.9	23.1	
Hori	2499.882	AV	49.3	26.9	3.2	32.7	46.7	53.9	7.2	
Hori	3132.323	AV	42.2	27.5	3.6	32.4	40.9	53.9	13.0	
Hori	4924.000	AV	32.6	30.8	4.4	31.7	36.1	53.9	17.8	Floor Noise
Hori	7386.000	AV	33.0	35.9	5.6	32.7	41.8	53.9	12.1	Floor Noise
Hori	8195.917	AV	36.6	37.1	5.8	32.9	46.6	53.9	7.3	
Hori	9848.000	AV	33.4	38.8	6.5	33.5	45.2	53.9	8.7	Floor Noise
Vert	1250.000	PK	54.5	24.7	2.4	34.6	47.0	73.9	26.9	
Vert	1837.880	PK	64.8	25.9	2.9	33.3	60.3	73.9	13.6	
Vert	2483.500	PK	43.6	26.9	3.2	32.7	41.0	73.9	32.9	
Vert	2499.882	PK	52.1	26.9	3.2	32.7	49.5	73.9	24.4	
Vert	3132.323	PK	51.5	27.5	3.6	32.4	50.2	73.9	23.7	
Vert	4924.000	PK	43.2	30.8	4.4	31.7	46.7	73.9	27.2	Floor Noise
Vert	7386.000	PK	43.3	35.9	5.6	32.7	52.1	73.9	21.8	Floor Noise
Vert	8195.110	PK	47.8	37.1	5.8	32.9	57.8	73.9	16.1	
Vert	9848.000	PK	42.5	38.8	6.5	33.5	54.3	73.9	19.6	Floor Noise
Vert	1250.000	AV	53.7	24.7	2.4	34.6	46.2	53.9	7.7	
Vert	1837.880	AV	56.1	25.9	2.9	33.3	51.6	53.9	2.3	
Vert	2483.500	AV	33.7	26.9	3.2	32.7	31.1	53.9	22.8	
Vert	2499.882	AV	48.1	26.9	3.2	32.7	45.5	53.9	8.4	
Vert	3132.323	AV	45.7	27.5	3.6	32.4	44.4	53.9	9.5	
Vert	4924.000	AV	32.3	30.8	4.4	31.7	35.8	53.9	18.1	Floor Noise
Vert	7386.000	AV	33.0	35.9	5.6	32.7	41.8	53.9	12.1	Floor Noise
Vert	8195.110	AV	36.7	37.1	5.8	32.9	46.7	53.9	7.2	
Vert	9848.000	AV	33.5	38.8	6.5	33.5	45.3	53.9	8.6	Floor Noise

Result = Reading + Ant Factor + Loss (Cable+Attenuator+Filter-Distance factor(above 10GHz)) - Gain(Amplifier)

*Other frequency noises omitted in this report were not seen or had enough margin (more than 20dB).

Distance factor: 10GHz-26.5GHz 20log(3.0m/1.0m)= 9.5dB

*Noises that had duty cycle synchronized with the fundamental frequency were not detected at the band-edge and harmonics frequencies.

Radiated Spurious Emission

Test place : Ise EMC Lab. No. 2 Semi Anechoic Chamber
Report No. : 10607274H
Date : 06/24/2015
Temperature/ Humidity : 25 deg. C / 43% RH
Engineer : Tsubasa Takayama
(30MHz-26.5GHz)
Mode : 11n-20 Tx 2412MHz + 11a Tx 5180MHz Co location transmitting

Polarity	Frequency [MHz]	Detector	Reading [dBuV]	Ant.Fac. [dB/m]	Loss [dB]	Gain [dB]	Result [dBuV/m]	Limit [dBuV/m]	Margin [dB]	Remark
Hori	146.100	QP	35.8	14.7	7.8	28.1	30.2	43.5	13.3	
Hori	249.987	QP	25.3	17.2	8.5	27.6	23.4	46.0	22.6	
Hori	341.251	QP	35.2	15.9	9.1	27.8	32.4	46.0	13.6	
Hori	374.949	QP	35.4	16.9	9.3	28.1	33.5	46.0	12.5	
Hori	720.002	QP	30.5	20.9	10.7	28.0	34.1	46.0	11.9	
Hori	786.503	QP	29.4	21.7	11.0	27.7	34.4	46.0	11.6	
Hori	983.006	QP	33.7	23.4	11.6	27.1	41.6	53.9	12.3	
Hori	1249.982	PK	61.6	25.8	2.0	35.8	53.6	73.9	20.3	
Hori	1844.828	PK	62.6	28.5	2.4	35.2	58.3	73.9	15.6	
Hori	2390.000	PK	45.1	29.3	2.8	35.0	42.2	73.9	31.7	
Hori	3750.349	PK	49.9	30.5	3.5	34.1	49.8	73.9	24.1	
Hori	4824.000	PK	44.5	32.7	4.0	34.2	47.0	73.9	26.9	
Hori	7236.000	PK	44.3	36.8	5.1	34.1	52.1	73.9	21.8	
Hori	9648.000	PK	43.5	38.9	6.0	34.7	53.7	73.9	20.2	
Hori	10360.000	PK	45.7	40.0	-3.3	34.4	48.0	73.9	25.9	Floor Noise
Hori	12060.000	PK	45.3	40.3	-2.7	33.5	49.4	73.9	24.5	Floor Noise
Hori	14472.000	PK	45.3	41.6	-2.4	32.8	51.7	73.9	22.2	Floor Noise
Hori	15540.000	PK	45.1	39.6	-2.1	33.5	49.1	73.9	24.8	Floor Noise
Hori	16884.000	PK	45.0	41.3	-1.8	32.8	51.7	73.9	22.2	Floor Noise
Hori	1249.982	AV	53.2	25.8	2.0	35.8	45.2	53.9	8.7	
Hori	1844.828	AV	50.1	28.5	2.4	35.2	45.8	53.9	8.1	
Hori	2390.000	AV	35.8	29.3	2.8	35.0	32.9	53.9	21.0	
Hori	3750.349	AV	39.7	30.5	3.5	34.1	39.6	53.9	14.3	
Hori	4824.000	AV	35.6	32.7	4.0	34.2	38.1	53.9	15.8	
Hori	7236.000	AV	34.5	36.8	5.1	34.1	42.3	53.9	11.6	
Hori	9648.000	AV	33.4	38.9	6.0	34.7	43.6	53.9	10.3	
Hori	10360.000	AV	35.6	40.0	-3.3	34.4	37.9	53.9	16.0	Floor Noise
Hori	12060.000	AV	35.4	40.3	-2.7	33.5	39.5	53.9	14.4	Floor Noise
Hori	14472.000	AV	35.2	41.6	-2.4	32.8	41.6	53.9	12.3	Floor Noise
Hori	15540.000	AV	34.5	39.6	-2.1	33.5	38.5	53.9	15.4	Floor Noise
Hori	16884.000	AV	34.0	41.3	-1.8	32.8	40.7	53.9	13.2	Floor Noise
Vert	48.750	QP	30.7	11.1	7.0	28.5	20.3	40.0	19.7	
Vert	146.250	QP	32.4	14.7	7.8	28.1	26.8	43.5	16.7	
Vert	249.987	QP	26.8	17.2	8.5	27.6	24.9	46.0	21.1	
Vert	341.266	QP	30.7	15.9	9.1	27.8	27.9	46.0	18.1	
Vert	374.970	QP	30.6	16.9	9.3	28.1	28.7	46.0	17.3	
Vert	719.960	QP	31.2	20.9	10.7	28.0	34.8	46.0	11.2	
Vert	786.403	QP	31.2	21.7	11.0	27.7	36.2	46.0	9.8	
Vert	982.506	QP	37.6	23.4	11.6	27.1	45.5	53.9	8.4	
Vert	1249.931	PK	59.2	25.8	2.0	35.8	51.2	73.9	22.7	
Vert	1844.828	PK	63.9	28.5	2.4	35.2	59.6	73.9	14.3	
Vert	2390.000	PK	44.3	29.3	2.8	35.0	41.4	73.9	32.5	
Vert	3750.349	PK	52.4	30.5	3.5	34.1	52.3	73.9	21.6	
Vert	4824.000	PK	44.0	32.7	4.0	34.2	46.5	73.9	27.4	
Vert	7236.000	PK	45.1	36.8	5.1	34.1	52.9	73.9	21.0	
Vert	9648.000	PK	44.9	38.9	6.0	34.7	55.1	73.9	18.8	
Vert	10360.000	PK	45.6	40.0	-3.3	34.4	47.9	73.9	26.0	Floor Noise
Vert	12060.000	PK	45.3	40.3	-2.7	33.5	49.4	73.9	24.5	Floor Noise
Vert	14472.000	PK	45.6	41.6	-2.4	32.8	52.0	73.9	21.9	Floor Noise
Vert	15540.000	PK	45.4	39.6	-2.1	33.5	49.4	73.9	24.5	Floor Noise
Vert	16884.000	PK	45.6	41.3	-1.8	32.8	52.3	73.9	21.6	Floor Noise
Vert	1249.931	AV	55.2	25.8	2.0	35.8	47.2	53.9	6.7	
Vert	1844.828	AV	51.7	28.5	2.4	35.2	47.4	53.9	6.5	
Vert	2390.000	AV	34.8	29.3	2.8	35.0	31.9	53.9	22.0	
Vert	3750.349	AV	42.4	30.5	3.5	34.1	42.3	53.9	11.6	
Vert	4824.000	AV	35.6	32.7	4.0	34.2	38.1	53.9	15.8	
Vert	7236.000	AV	36.3	36.8	5.1	34.1	44.1	53.9	9.8	
Vert	9648.000	AV	33.4	38.9	6.0	34.7	43.6	53.9	10.3	
Vert	10360.000	AV	35.6	40.0	-3.3	34.4	37.9	53.9	16.0	Floor Noise
Vert	12060.000	AV	35.4	40.3	-2.7	33.5	39.5	53.9	14.4	Floor Noise
Vert	14472.000	AV	35.2	41.6	-2.4	32.8	41.6	53.9	12.3	Floor Noise
Vert	15540.000	AV	35.0	39.6	-2.1	33.5	39.0	53.9	14.9	Floor Noise
Vert	16884.000	AV	34.0	41.3	-1.8	32.8	40.7	53.9	13.2	Floor Noise

Result = Reading + Ant Factor + Loss (Cable+Attenuator+Filter-Distance factor(above 10GHz)) - Gain(Amplifier)

*Other frequency noises omitted in this report were not seen or had enough margin (more than 20dB).

Distance factor: 10GHz-26.5GHz 20log(3.0m/1.0m)= 9.5dB

*Noises that had duty cycle synchronized with the fundamental frequency were not detected at the band-edge and harmonics frequencies.

Radiated Spurious Emission (Plot data, Worst case)

Test place	Ise EMC Lab. No. 2 Semi Anechoic Chamber
Report No.	10607274H
Date	06/24/2015
Temperature/ Humidity	25 deg. C / 43% RH
Engineer	Tsubasa Takayama
	(30MHz-26.5GHz)
Mode	11n-20 Tx 2412MHz + 11a Tx 5180MHz Co location transmitting

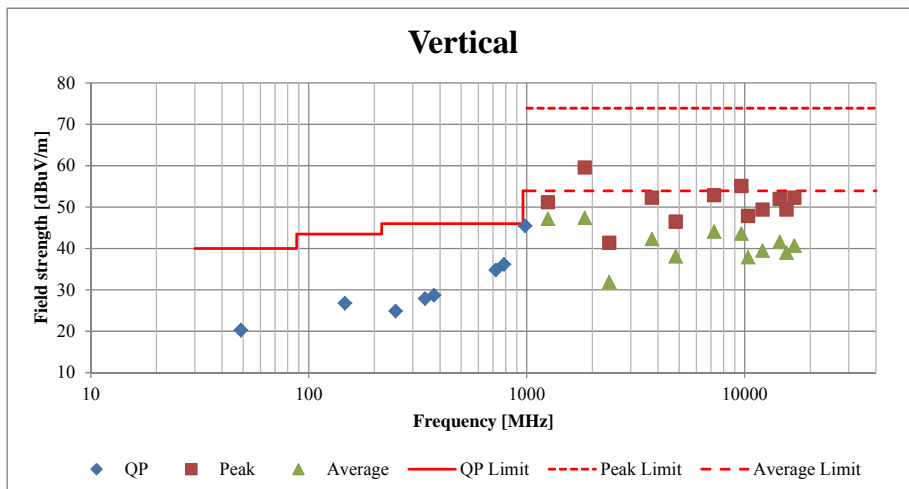
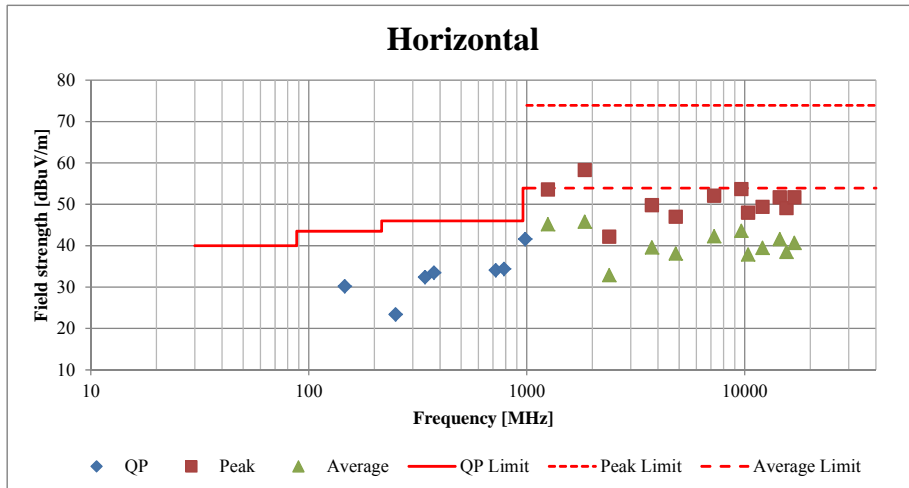

Radiated Spurious Emission

Test place : Ise EMC Lab. No.2 Semi Anechoic Chamber
 Report No. : 10607274H
 Date : 06/24/2015
 Temperature/ Humidity : 25 deg. C / 43% RH
 Engineer : Tsubasa Takayama
 (1-10GHz)
 Mode : 11n-20 Tx 2412MHz + 11a Tx 5180MHz Co location transmitting

20dBc Data Sheet

Polarity	Frequency [MHz]	Detector	Reading [dBuV]	Ant Factor [dB/m]	Loss [dB]	Gain [dB]	Result [dBuV/m]	Limit [dBuV/m]	Margin [dB]	Remark
Hori	2412.000	PK	89.2	29.3	2.8	35.0	86.3	-	-	Carrier
Hori	2400.000	PK	49.3	29.3	2.8	35.0	46.4	66.3	19.9	
Vert	2412.000	PK	89.6	29.3	2.8	35.0	86.7	-	-	Carrier
Vert	2400.000	PK	48.3	29.3	2.8	35.0	45.4	66.7	21.3	

Result = Reading + Ant Factor + Loss (Cable+Attenuator+Filter-Distance factor(above 10GHz)) - Gain(Amplifier)

UL Japan, Inc.

Ise EMC Lab.

4383-326 Asama-cho, Ise-shi, Mie-ken 516-0021 JAPAN

Telephone : +81 596 24 8999

Facsimile : +81 596 24 8124

Radiated Spurious Emission

Test place : Ise EMC Lab. No.2 Semi Anechoic Chamber
 Report No. : 10607274H
 Date : 06/24/2015
 Temperature/ Humidity : 25 deg. C / 43% RH
 Engineer : Tsubasa Takayama
 (1-10GHz)
 Mode : 11n-20 Tx 2462MHz + 11a Tx 5180MHz Co location transmitting

Polarity	Frequency [MHz]	Detector	Reading [dBuV]	Ant.Fac. [dB/m]	Loss [dB]	Gain [dB]	Result [dBuV/m]	Limit [dBuV/m]	Margin [dB]	Remark
Hori	2483.500	PK	45.4	29.3	2.8	34.9	42.6	73.9	31.3	
Hori	2483.500	AV	35.5	29.3	2.8	34.9	32.7	53.9	21.2	
Vert	2483.500	PK	45.9	29.3	2.8	34.9	43.1	73.9	30.8	
Vert	2483.500	AV	35.8	29.3	2.8	34.9	33.0	53.9	20.9	

Result = Reading + Ant Factor + Loss (Cable+Attenuator+Filter-Distance factor(above 10GHz)) - Gain(Amplifier)

*Other frequency noises omitted in this report were not seen or had enough margin (more than 20dB).

Distance factor: 10GHz-26.5GHz $20\log(3.0m/1.0m) = 9.5dB$

*Noises that had duty cycle synchronized with the fundamental frequency were not detected at the band-edge and harmonics frequencies.

UL Japan, Inc.

Ise EMC Lab.

4383-326 Asama-cho, Ise-shi, Mie-ken 516-0021 JAPAN

Telephone : +81 596 24 8999

Facsimile : +81 596 24 8124

Band Edge confirmation

Test place	Ise EMC Lab. No.3 Semi Anechoic Chamber
Report No.	10607274H
Date	03/03/2015
Temperature/ Humidity	23 deg. C / 37% RH
Engineer	Koji Yamamoto
Mode	11b/11n-20 Tx

11b

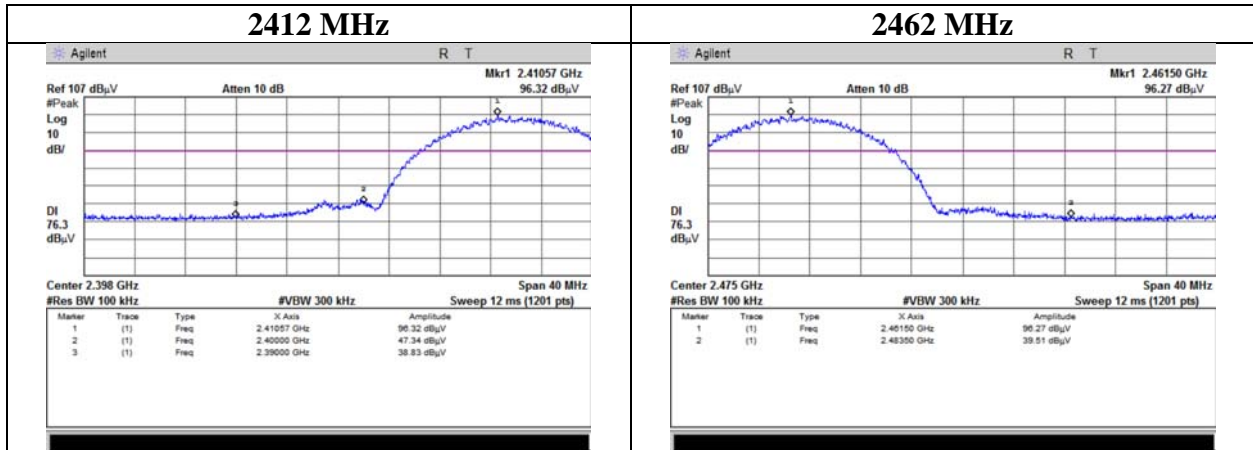

11n-20



* Final result of band edge was measured as radiated spurious emission. Refer to Radiated Spurious Emission's pages.

Burst rate confirmation

Test place	Ise EMC Lab. No.3 Anechoic Chamber
Report No.	10607274H
Date	03/03/2015
Temperature/ Humidity	23deg. C / 40% RH
Engineer	Takafumi Noguchi
Mode	11b Tx / 11g Tx / 11n-20 Tx

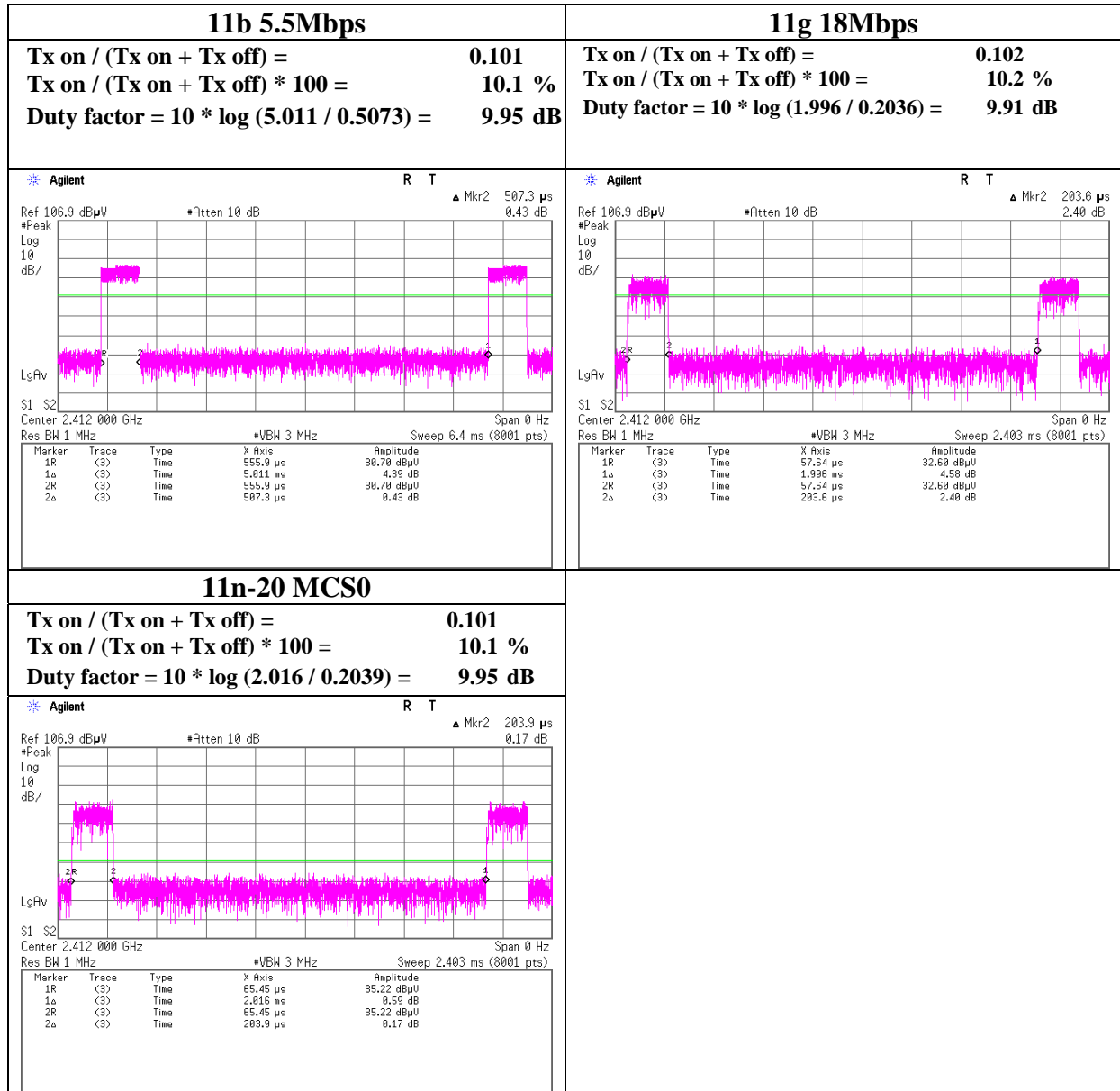

UL Japan, Inc.
Ise EMC Lab.

4383-326 Asama-cho, Ise-shi, Mie-ken 516-0021 JAPAN
 Telephone : +81 596 24 8999
 Facsimile : +81 596 24 8124

Conducted Spurious Emission

Test place	Ise EMC Lab. No.11 Measurement Room
Report No.	10607274H
Date	03/04/2015
Temperature/ Humidity	22 deg. C / 32% RH
Engineer	Tsubasa Takayama
Mode	11n-20 Tx

11n-20 Tx 2412MHz

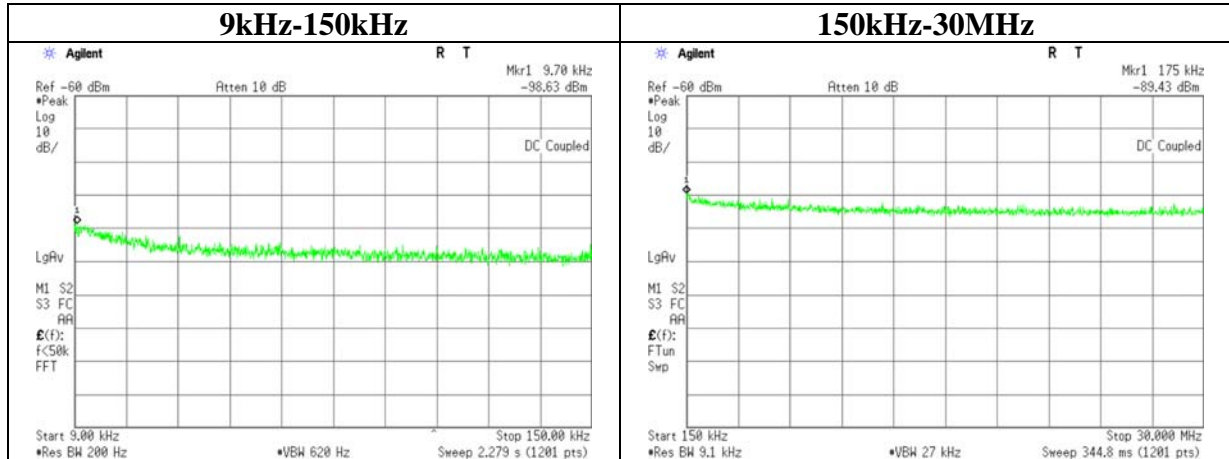

Frequency [kHz]	Reading [dBm]	Cable Loss [dB]	Attenuator [dB]	Antenna Gain [dBi]	EIRP [dBm]	Distance [m]	Ground bounce [dB]	E (field strength) [dBuV/m]	Limit [dBuV/m]	Margin [dB]
9.70	-98.6	1.00	9.8	3.3	-84.5	300	6.0	-23.2	47.8	71.0
175.00	-89.4	1.00	9.8	3.3	-75.3	300	6.0	-14.0	22.7	36.7

$E = \text{EIRP} - 20 \log(D) + \text{Ground bounce} + 104.8 [\text{dBuV/m}]$

$\text{EIRP} = \text{Reading} + \text{Cable Loss (including customer supply cable)} + \text{Attenuator} + \text{Antenna Gain} + 10 * \log(N)$

UL Japan, Inc.

Ise EMC Lab.

4383-326 Asama-cho, Ise-shi, Mie-ken 516-0021 JAPAN

Telephone : +81 596 24 8999

Facsimile : +81 596 24 8124

Power Density

Test place	Ise EMC Lab. No.11 Measurement Room
Report No.	10607274H
Date	03/04/2015
Temperature/ Humidity	22 deg. C / 32% RH
Engineer	Tsubasa Takayama
Mode	11b Tx / 11g Tx / 11n-20 Tx

11b

Freq.	Reading	Cable Loss	Atten.	Result	Limit	Margin
[MHz]	[dBm]	[dB]	[dB]	[dBm]	[dBm]	[dB]
2412.00	-12.31	2.32	10.08	0.09	8.00	7.91
2437.00	-22.62	2.32	10.08	-10.22	8.00	18.22
2462.00	-23.50	2.33	10.08	-11.09	8.00	19.09

11g

Freq.	Reading	Cable Loss	Atten.	Result	Limit	Margin
[MHz]	[dBm]	[dB]	[dB]	[dBm]	[dBm]	[dB]
2412.00	-30.96	2.32	10.08	-18.56	8.00	26.56
2437.00	-30.81	2.32	10.08	-18.41	8.00	26.41
2462.00	-31.16	2.33	10.08	-18.75	8.00	26.75

11n-20

Freq.	Reading	Cable Loss	Atten.	Result	Limit	Margin
[MHz]	[dBm]	[dB]	[dB]	[dBm]	[dBm]	[dB]
2412.00	-30.22	2.32	10.08	-17.82	8.00	25.82
2437.00	-30.27	2.32	10.08	-17.87	8.00	25.87
2462.00	-30.25	2.33	10.08	-17.84	8.00	25.84

Sample Calculation:

Result = Reading + Cable Loss (including Cable(s) Customer Supplied) + Attenuator

UL Japan, Inc.

Ise EMC Lab.

4383-326 Asama-cho, Ise-shi, Mie-ken 516-0021 JAPAN

Telephone : +81 596 24 8999

Facsimile : +81 596 24 8124

Power Density

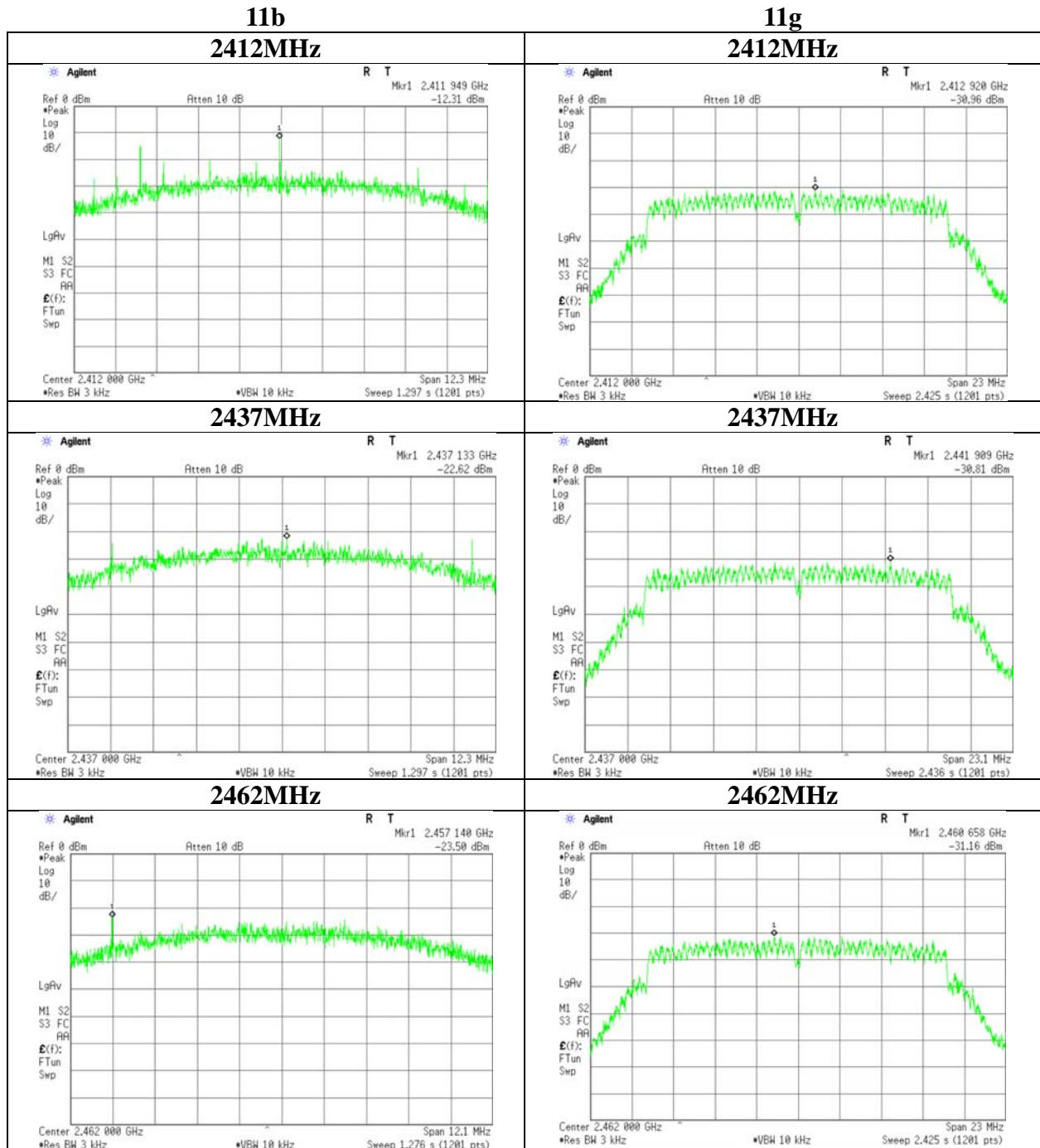

UL Japan, Inc.

Ise EMC Lab.

4383-326 Asama-cho, Ise-shi, Mie-ken 516-0021 JAPAN

Telephone : +81 596 24 8999

Facsimile : +81 596 24 8124

Power Density

11n-20

2412MHz

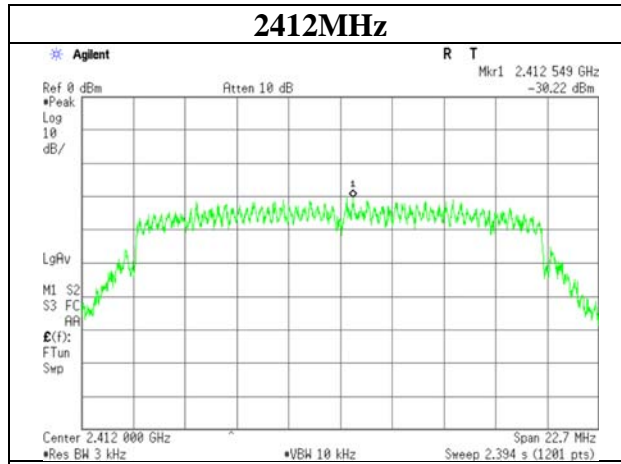

2437MHz

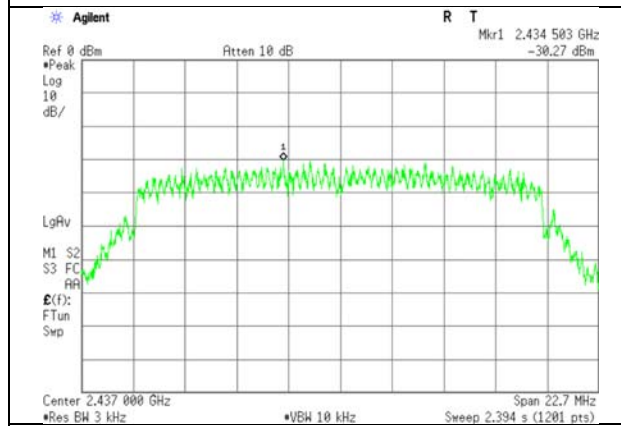

2462MHz

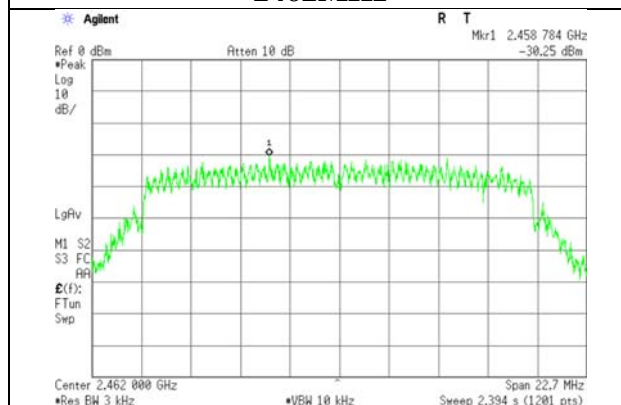

UL Japan, Inc.
Ise EMC Lab.

4383-326 Asama-cho, Ise-shi, Mie-ken 516-0021 JAPAN

Telephone : +81 596 24 8999

Facsimile : +81 596 24 8124

99%Occupied Bandwidth

Test place	Ise EMC Lab. No.11 Measurement Room
Report No.	10607274H
Date	03/04/2015
Temperature/ Humidity	22 deg. C / 32% RH
Engineer	Tsubasa Takayama
Mode	11b Tx / 11g Tx

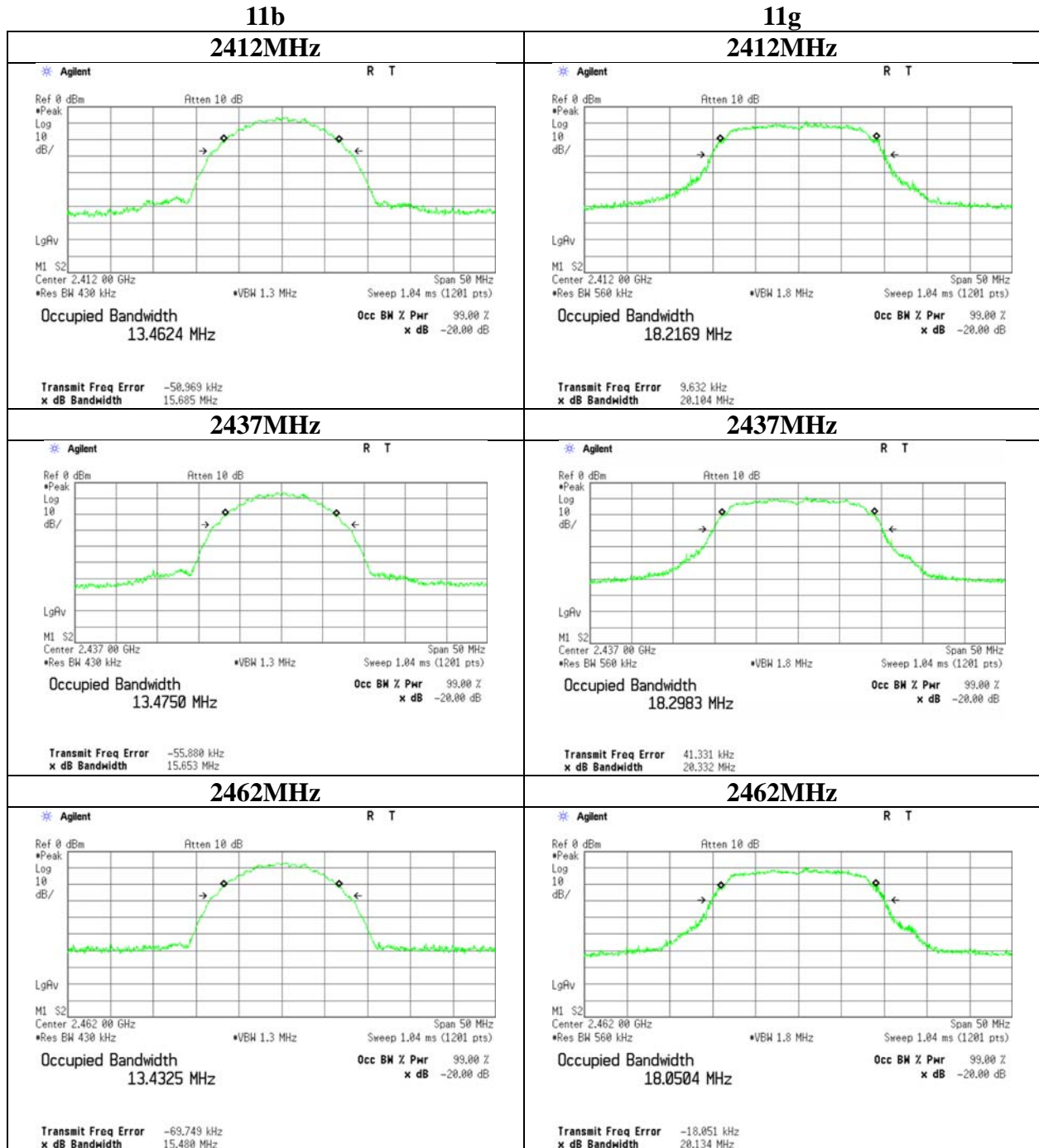

99% Occupied Bandwidth

Test place : Ise EMC Lab. No.11 Measurement Room
 Report No. : 10607274H
 Date : 03/04/2015
 Temperature/ Humidity : 22 deg. C / 32% RH
 Engineer : Tsubasa Takayama
 Mode : 11n-20 Tx

11n-20

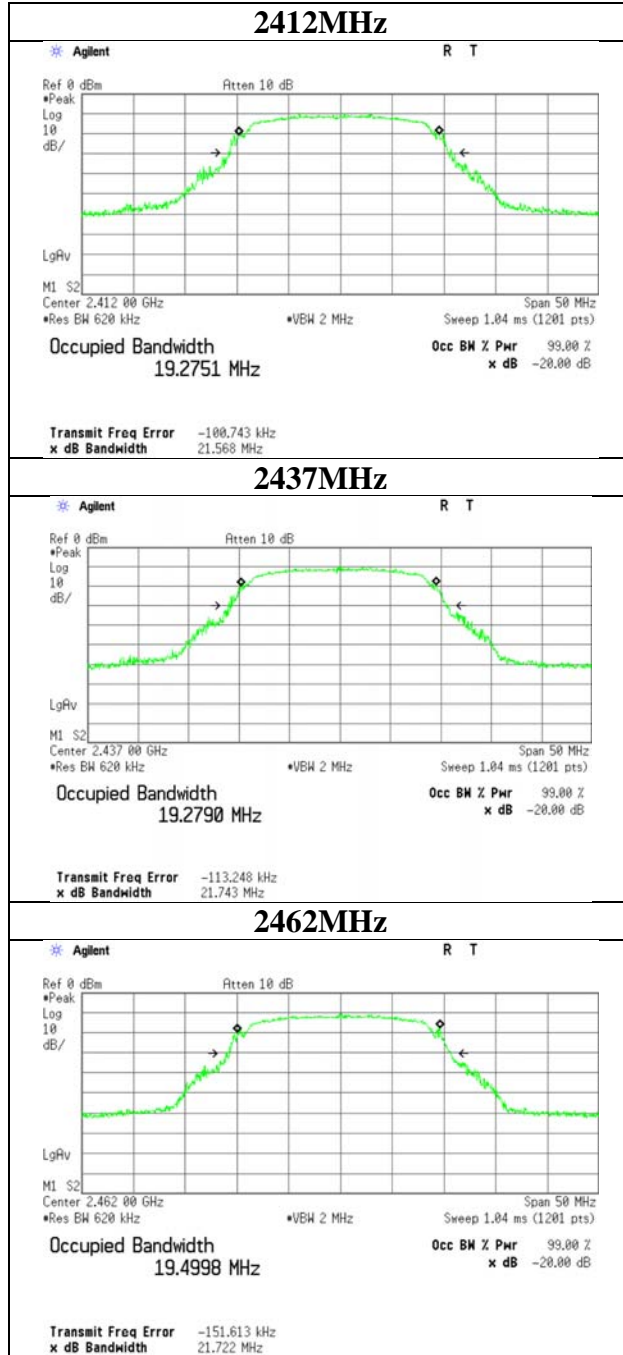

APPENDIX 2: Test instruments

EMI test equipment (1/2)

Control No.	Instrument	Manufacturer	Model No	Serial No	Test Item	Calibration Date * Interval(month)
MRENT-116	Spectrum Analyzer	Agilent	E4440A	MY46187620	AT	2015/03/09 * 12
MPM-12	Power Meter	Anritsu	ML2495A	0825002	AT	2014/06/16 * 12
MPSE-17	Power sensor	Anritsu	MA2411B	0738285	AT	2014/06/16 * 12
MPSE-22	Power sensor	Agilent	N1923A	MY54070003	AT	2014/04/04 * 12 *1)
MPM-16	Power Meter	Agilent	8990B	MY51000271	AT	2014/04/04 * 12 *1)
MAT-23	Attenuator(10dB) 1-18GHz	Orient Microwave	BX10-0476-00	-	AT	2014/03/13 * 12 *1)
MCC-66	Microwave Cable 1G-40GHz	Suhner	SUCOFLEX102	28636/2	AT	2014/04/09 * 12 *1)
MOS-19	Thermo-Hygrometer	Custom	CTH-201	0001	AT	2014/12/22 * 12
MCC-38	Coaxial Cable	UL Japan	-	-	AT	2014/12/02 * 12
MAT-10	Attenuator(10dB)	Weinschel Corp	2	BL1173	AT	2014/11/19 * 12
MSA-16	Spectrum Analyzer	Agilent	E4440A	MY46186390	AT	2015/02/16 * 12
MAEC-03	Semi Anechoic Chamber(NSA)	TDK	Semi Anechoic Chamber 3m	DA-10005	RE	2015/02/19 * 12
MOS-13	Thermo-Hygrometer	Custom	CTH-180	1301	RE	2015/01/13 * 12
MJM-16	Measure	KOMELON	KMC-36	-	RE	-
COTS-MEMI	EMI measurement program	TSJ	TEPTO-DV	-	RE	-
MSA-03	Spectrum Analyzer	Agilent	E4448A	MY44020357	RE	2014/04/08 * 12 *1)
MHA-20	Horn Antenna 1-18GHz	Schwarzbeck	BBHA9120D	258	RE	2014/05/26 * 12 *1)
MCC-167	Microwave Cable	Junkosha	MWX221	1404S374(1m) / 1405S074(5m)	RE	2014/05/26 * 12 *1)
MPA-11	MicroWave System Amplifier	Agilent	83017A	MY39500779	RE	2014/03/24 * 12 *1)
MHF-25	High Pass Filter 3.5-18.0GHz	UL Japan	HPF SELECTOR	001	RE	2014/09/22 * 12
MHA-16	Horn Antenna 15-40GHz	Schwarzbeck	BBHA9170	BBHA9170306	RE	2014/05/26 * 12 *1)
MHF-22	High Pass Filter 7-20GHz	TOKIMEC	TF37NCCB	602	RE	2015/01/27 * 12
MCC-79	Microwave Cable 1G-26.5GHz	Suhner	SUCOFLEX104	278923/4	RE	2014/12/15 * 12
MPA-22	Pre Amplifier	MITEQ, Inc	AMF-6F-2600400-33-8P / AMF-4F-2600400-33-8P	1871355 / 1871328	RE	2014/09/11 * 12
MHA-29	Horn Antenna 26.5-40GHz	ETS LINDGREN	3160-10	00152399	RE	2014/09/02 * 12
MCC-54	Microwave Cable	Suhner	SUCOFLEX101	2873(1m) / 2876(5m)	RE	2014/03/11 * 12 *1)
MTR-08	Test Receiver	Rohde & Schwarz	ESCI	100767	RE	2014/08/19 * 12
MBA-03	Biconical Antenna	Schwarzbeck	BBA9106	1915	RE	2014/10/18 * 12
MLA-03	Logperiodic Antenna	Schwarzbeck	USLP9143	174	RE	2014/10/18 * 12
MCC-51	Coaxial cable	UL Japan	-	-	RE	2014/07/14 * 12
MAT-70	Attenuator(6dB)	Agilent	8491A-006	MY52460153	RE	2014/04/14 * 12 *1)
MPA-13	Pre Amplifier	SONOMA INSTRUMENT	310	260834	RE	2015/03/10 * 12
MHA-06	Horn Antenna 1-18GHz	Schwarzbeck	BBHA9120D	254	RE	2015/02/05 * 12
MPA-03	Microwave System Power Amplifier	Agilent	83050A	3950M00205	RE	2015/06/02 * 12
MHA-16	Horn Antenna 15-40GHz	Schwarzbeck	BBHA9170	BBHA9170306	RE	2015/05/19 * 12
MAEC-02	Semi Anechoic Chamber(NSA)	TDK	Semi Anechoic Chamber 3m	DA-06902	RE	2014/06/25 * 12
MOS-22	Thermo-Hygrometer	Custom	CTH-201	0003	RE	2015/01/13 * 12
MJM-14	Measure	KOMELON	KMC-36	-	RE	-

*1) This test equipment was used for the tests before the expiration date of the calibration.

UL Japan, Inc.

Ise EMC Lab.

4383-326 Asama-cho, Ise-shi, Mie-ken 516-0021 JAPAN

Telephone : +81 596 24 8999

Facsimile : +81 596 24 8124

EMI test equipment (2/2)

Control No.	Instrument	Manufacturer	Model No	Serial No	Test Item	Calibration Date * Interval(month)
MSA-04	Spectrum Analyzer	Agilent	E4448A	US44300523	RE	2014/11/12 * 12
MTR-03	Test Receiver	Rohde & Schwarz	ESCI	100300	RE	2015/06/08 * 12
MBA-02	Biconical Antenna	Schwarzbeck	BBA9106	VHA91032008	RE	2014/10/18 * 12
MLA-02	Logperiodic Antenna	Schwarzbeck	USLP9143	201	RE	2014/10/18 * 12
MCC-12	Coaxial Cable	Fujikura/Agilent	-	-	RE	2015/02/06 * 12
MAT-07	Attenuator(6dB)	Weinschel Corp	2	BK7970	RE	2014/11/11 * 12
MPA-09	Pre Amplifier	Agilent	8447D	2944A10845	RE	2014/09/26 * 12
MCC-166	Microwave Cable	Junkosha	MWX221	1303S120(1m) / 1311S167(5m)	RE	2014/09/24 * 12
MPA-10	Pre Amplifier	Agilent	8449B	3008A02142	RE	2015/01/28 * 12

The expiration date of the calibration is the end of the expired month.

All equipment is calibrated with valid calibrations. Each measurement data is traceable to the national or international standards.

As for some calibrations performed after the tested dates, those test equipment have been controlled by means of an unbroken chains of calibrations.

**Test Item: RE: Radiated Emission test
AT: Antenna Terminal Conducted test**