



# RADIO TEST REPORT

Test Report No. : 10607274H-B

**Applicant** : MITSUBISHI ELECTRIC CORPORATION SANDA WORKS

**Type of Equipment** : HEADUNIT A-HIGH

**Model No.** : NR-213

**FCC ID** : UJHNR213

**Test regulation** : FCC Part 15 Subpart C: 2015 (Bluetooth Part)

**Test Result** : Complied

1. This test report shall not be reproduced in full or partial, without the written approval of UL Japan, Inc.
2. The results in this report apply only to the sample tested.
3. This sample tested is in compliance with the above regulation.
4. The test results in this report are traceable to the national or international standards.
5. This test report must not be used by the customer to claim product certification, approval, or endorsement by NVLAP, NIST, or any agency of the Federal Government.
6. This test report covers Radio technical requirements. It does not cover administrative issues such as Manual or non-Radio test related Requirements. (if applicable)

**Date of test:** February 27 to March 11, 2015

**Representative test engineer:**

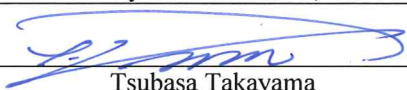

Tsubasa Takayama  
Engineer  
Consumer Technology Division

**Approved by:**



Takahiro Hatakeda  
Leader  
Consumer Technology Division



NVLAP LAB CODE: 200572-0

This laboratory is accredited by the NVLAP LAB CODE 200572-0, U.S.A. The tests reported herein have been performed in accordance with its terms of accreditation.

\*As for the range of Accreditation in NVLAP, you may refer to the WEB address,

<http://www.ul.com/japan/jpn/pages/services/emc/about/mark1/index.jsp#nvlap>

**UL Japan, Inc.**  
**Ise EMC Lab.**

4383-326 Asama-cho, Ise-shi, Mie-ken 516-0021 JAPAN

Telephone : +81 596 24 8999

Facsimile : +81 596 24 8124

13-EM-F0429



<b>CONTENTS</b>	<b>PAGE</b>
<b>SECTION 1: Customer information.....</b>	<b>4</b>
<b>SECTION 2: Equipment under test (E.U.T.).....</b>	<b>4</b>
<b>SECTION 3: Test specification, procedures &amp; results.....</b>	<b>5</b>
<b>SECTION 4: Operation of E.U.T. during testing .....</b>	<b>8</b>
<b>SECTION 5: Radiated Spurious Emission .....</b>	<b>11</b>
<b>SECTION 6: Antenna Terminal Conducted Tests.....</b>	<b>12</b>
<b>APPENDIX 1: Data of EMI test.....</b>	<b>13</b>
20dB Bandwidth and Carrier Frequency Separation.....	13
Number of Hopping Frequency .....	16
Dwell time.....	18
Maximum Peak Output Power .....	21
Radiated Spurious Emission .....	23
Conducted Spurious Emission .....	33
Conducted Emission Band Edge compliance .....	45
99%Occupied Bandwidth .....	47
<b>APPENDIX 2: Test instruments .....</b>	<b>49</b>
<b>APPENDIX 3: Photographs of test setup .....</b>	<b>51</b>
Radiated Spurious Emission .....	51
Worst Case Position (Horizontal: X-axis/ Vertical:Y-axis).....	52

## **SECTION 1: Customer information**

Company Name : MITSUBISHI ELECTRIC CORPORATION SANDA WORKS  
Address : 2-3-33, Miwa, Sanda-city, Hyogo, 669-1513, Japan  
Telephone Number : +81-79-559-3607  
Facsimile Number : +81-79-559-3875  
Contact Person : Yuji Funaba

## **SECTION 2: Equipment under test (E.U.T.)**

### **2.1 Identification of E.U.T.**

Type of Equipment : HEADUNIT A-HIGH  
Model No. : NR-213  
Serial No. : Refer to Clause 4.2  
Rating : DC 12 V  
Receipt Date of Sample : February 26, 2015  
Country of Mass-production : Japan  
Condition of EUT : Production prototype  
(Not for Sale: This sample is equivalent to mass-produced items.)  
Modification of EUT : No Modification by the test lab

### **2.2 Product Description**

#### **General Specification**

Clock frequency(ies) in the system : 1.4 GHz,  
40 MHz (Radio part)

#### **Radio Specification**

	IEEE802.11b	IEEE802.11g/n (20 M band)	IEEE802.11a/n (20 M band)	IEEE802.11n (40 M band)	Bluetooth Ver.3.0 with EDR function
Frequency of operation	2412-2462MHz	2412-2462MHz	5180-5240MHz 5260-5320MHz 5500-5700MHz 5745-5825MHz	5190-5230MHz 5270-5310MHz 5510-5670MHz 5755-5795MHz	2402-2480MHz *1)
Type of modulation	DSSS (CCK, DQPSK, DBPSK)	OFDM-CCK (64QAM, 16QAM, QPSK, BPSK)	OFDM (64QAM, 16QAM, QPSK, BPSK)		FHSS (GFSK, $\pi/4$ -DQPSK, 8-DPSK)
Channel spacing	5MHz		20MHz	40MHz	1MHz
Antenna type	Printed patch Antenna				Dipole Pattern Antenna
Antenna Gain	3.3dBi		6.5dBi		2.32dBi
Antenna Connector type	FAKRA				PSE-LP2

\*1) This test report applies for Bluetooth Ver.3.0 with EDR function

	GPS/GLONASS
Frequency of operation	GPS: 1575.42MHz GLONASS: 1597.55-1605.89MHz
Type of modulation	GPS: BPSK GLONASS: BPSK
Channel spacing	GLONASS: 0.5625MHz
Antenna type	Active antenna
Antenna Connector type	FAKRA
Antenna Gain	25dBi

**UL Japan, Inc.**

**Ise EMC Lab.**

4383-326 Asama-cho, Ise-shi, Mie-ken 516-0021 JAPAN

Telephone : +81 596 24 8999

Facsimile : +81 596 24 8124

## **SECTION 3: Test specification, procedures & results**

### **3.1 Test Specification**

Test Specification : FCC Part 15 Subpart C: 2015, final revised on January 21, 2015

Title : FCC 47CFR Part15 Radio Frequency Device Subpart C Intentional Radiators  
Section 15.207 Conducted limits  
Section 15.247 Operation within the bands 902-928MHz,  
2400-2483.5MHz, and 5725-5850MHz

### **3.2 Procedures and results**

Item	Test Procedure	Specification	Worst Margin	Results	Remarks
Conducted Emission	FCC: ANSI C63.4:2009 7. AC powerline conducted emission measurements IC: RSS-Gen 8.8	FCC: Section 15.207 ----- IC: RSS-Gen 8.8	N/A	N/A *1)	-
Carrier Frequency Separation	FCC: FCC Public Notice DA 00-705 IC: -	FCC: Section15.247(a)(1) ----- IC: RSS-247 5.1 (2)	See data.	Complied	Conducted
20dB Bandwidth	FCC: FCC Public Notice DA 00-705 IC: -	FCC: Section15.247(a)(1) ----- IC: RSS-247 5.1 (1)		Complied	Conducted
Number of Hopping Frequency	FCC: FCC Public Notice DA 00-705 IC: -	FCC: Section15.247(a)(1)(iii) ----- IC: RSS-247 5.1 (4)		Complied	Conducted
Dwell time	FCC: FCC Public Notice DA 00-705 IC: -	FCC: Section15.247(a)(1)(iii) ----- IC: RSS-247 5.1 (4)		Complied	Conducted
Maximum Peak Output Power	FCC: FCC Public Notice DA 00-705 IC: RSS-Gen 6.12	FCC: Section15.247(a)(b)(1) ----- IC: RSS-247 5.4 (2)		Complied	Conducted
Spurious Emission & Band Edge Compliance	FCC: FCC Public Notice DA 00-705 IC: RSS-Gen 6.13	FCC: Section15.247(d) ----- IC: RSS-247 5.5 RSS-Gen 8.9 RSS-Gen 8.10		0.8dB 8196.630MHz, AV, Horizontal 8195.667MHz, AV, Vertical 8196.771MHz, AV, Horizontal	Complied
Note: UL Japan, Inc.'s EMI Work Procedures No. 13-EM-W0420 and 13-EM-W0422. *1) The test is not applicable since the EUT is not the device that is designed to be connected to the public utility (AC) power line.					

\* In case any questions arise about test procedure, ANSI C63.4: 2009 is also referred.

#### **FCC 15.31 (e)**

The EUT provides stable voltage (DC 3.3 V) constantly to the wireless transmitter regardless of input voltage. Instead of a new battery, DC power supply was used for the test. That does not affect the test result, therefore the EUT complies with the requirement.

#### **FCC Part 15.203 Antenna requirement**

It is impossible for end users to replace the antenna, because the antenna is mounted inside of the vehicle. Therefore, the equipment complies with the antenna requirement of Section 15.203.

**UL Japan, Inc.**

**Ise EMC Lab.**

4383-326 Asama-cho, Ise-shi, Mie-ken 516-0021 JAPAN

Telephone : +81 596 24 8999

Facsimile : +81 596 24 8124

### 3.3 Addition to standard

Item	Test Procedure	Specification	Worst margin	Results	Remarks
99% Occupied Bandwidth	IC: RSS-Gen 6.6	IC: -	N/A	-	Conducted

Other than above, no addition, exclusion nor deviation has been made from the standard.

### 3.4 Uncertainty

#### EMI

The following uncertainties have been calculated to provide a confidence level of 95% using a coverage factor k=2.

Test room (semi-anechoic chamber)	Radiated emission						
	(3m*)(+dB)				(1m*)(+dB)		(0.5m*)(+dB)
	9kHz -30MHz	30MHz -300MHz	300MHz -1GHz	1GHz -10GHz	10GHz -18GHz	18GHz -26.5GHz	26.5GHz -40GHz
No.1	4.3dB	5.5dB	6.3dB	5.5dB	5.8dB	5.8dB	4.3dB
No.2	4.2dB	5.4dB	6.3dB	5.4dB	5.7dB	5.9dB	5.6dB
No.3	4.4dB	5.4dB	6.4dB	5.2dB	5.5dB	5.8dB	5.5dB
No.4	4.7dB	5.6dB	6.4dB	5.3dB	5.7dB	5.9dB	5.5dB

\*3m/1m/0.5m = Measurement distance

Power meter (+dB)	
Below 1GHz	Above 1GHz
0.7dB	1.5dB

Antenna terminal conducted emission and Power density (+dB)			Antenna terminal conducted emission (+dB)		Channel power (+dB)
Below 1GHz	1GHz-3GHz	3GHz-18GHz	18GHz-26.5GHz	26.5GHz-40GHz	
1.5dB	1.7dB	2.8dB	2.8dB	2.9dB	2.6dB

#### Radiated emission test(3m)

The data listed in this report meets the limits unless the uncertainty is taken into consideration.

### 3.5 Test Location

UL Japan, Inc. Ise EMC Lab. \*NVLAP Lab. code: 200572-0  
4383-326 Asama-cho, Ise-shi, Mie-ken 516-0021 JAPAN  
Telephone : +81 596 24 8999 Facsimile : +81 596 24 8124

	IC Registration Number	Width x Depth x Height (m)	Size of reference ground plane (m) / horizontal conducting plane	Other rooms
No.1 semi-anechoic chamber	2973C-1	19.2 x 11.2 x 7.7m	7.0 x 6.0m	No.1 Power source room
No.2 semi-anechoic chamber	2973C-2	7.5 x 5.8 x 5.2m	4.0 x 4.0m	-
No.3 semi-anechoic chamber	2973C-3	12.0 x 8.5 x 5.9m	6.8 x 5.75m	No.3 Preparation room
No.3 shielded room	-	4.0 x 6.0 x 2.7m	N/A	-
No.4 semi-anechoic chamber	2973C-4	12.0 x 8.5 x 5.9m	6.8 x 5.75m	No.4 Preparation room
No.4 shielded room	-	4.0 x 6.0 x 2.7m	N/A	-
No.5 semi-anechoic chamber	-	6.0 x 6.0 x 3.9m	6.0 x 6.0m	-
No.6 shielded room	-	4.0 x 4.5 x 2.7m	4.0 x 4.5 m	-
No.6 measurement room	-	4.75 x 5.4 x 3.0m	4.75 x 4.15 m	-
No.7 shielded room	-	4.7 x 7.5 x 2.7m	4.7 x 7.5m	-
No.8 measurement room	-	3.1 x 5.0 x 2.7m	N/A	-
No.9 measurement room	-	8.0 x 4.6 x 2.8m	2.4 x 2.4m	-
No.11 measurement room	-	6.2 x 4.7 x 3.0m	4.8 x 4.6m	-

\* Size of vertical conducting plane (for Conducted Emission test) : 2.0 x 2.0m for No.1, No.2, No.3, and No.4 semi-anechoic chambers and No.3 and No.4 shielded rooms.

### 3.6 Data of EMI, Test instruments, and Test set up

Refer to APPENDIX.

## UL Japan, Inc. Ise EMC Lab.

4383-326 Asama-cho, Ise-shi, Mie-ken 516-0021 JAPAN  
Telephone : +81 596 24 8999  
Facsimile : +81 596 24 8124

## **SECTION 4: Operation of E.U.T. during testing**

### **4.1 Operating Mode(s)**

Bluetooth (BT): Transmitting (Tx), Payload: PRBS9  
Inquiry

Details of Operating Mode(s)

<b>Test Item</b>	<b>Mode</b>	<b>Tested frequency</b>
Spurious Emission (Conducted/Radiated)	Tx (Hopping off) DH5, 3DH5	2402MHz 2441MHz 2480MHz
Carrier Frequency Separation	Tx (Hopping on) DH5, 3DH5 Inquiry	2402MHz 2441MHz 2480MHz
20dB Bandwidth	Tx (Hopping off) DH5, 3DH5 Inquiry	2402MHz 2441MHz 2480MHz
Number of Hopping Frequency	Tx (Hopping on) DH5, 3DH5 Inquiry	-
Dwell time	Tx (Hopping on), -DH1, DH3, DH5 -3DH1, 3DH3, 3DH5 Inquiry	-
Maximum Peak Output Power	Tx (Hopping off) DH5, 2DH5, 3DH5 Inquiry	2402MHz 2441MHz 2480MHz
Band Edge Compliance (Conducted)	Tx DH5, 3DH5 -Hopping on -Hopping off	2402MHz 2480MHz
99% Occupied Bandwidth	Tx DH5, 3DH5 -Hopping on -Hopping off	2402MHz 2441MHz 2480MHz
<p>*As a result of preliminary test, the formal test was performed with the above modes, which had the maximum payload length (except Dwell time test)  *2DH mode (2Mb/s EDR: pi/4DQPSK) was excluded for other tests than power measurement by using 3DH mode (3 Mb/s EDR: 8DPSK) as a representative.  *EUT has the power settings by the software as follows;  Power settings: default  Software: Engineering mode E45.2  *This setting of software is the worst case.  Any conditions under the normal use do not exceed the condition of setting.  In addition, end users cannot change the settings of the output power of the product.</p>		

**UL Japan, Inc.**

**Ise EMC Lab.**

4383-326 Asama-cho, Ise-shi, Mie-ken 516-0021 JAPAN

Telephone : +81 596 24 8999

Facsimile : +81 596 24 8124



## 4.2 Configuration and peripherals

### [Radiated Spurious Emission test]

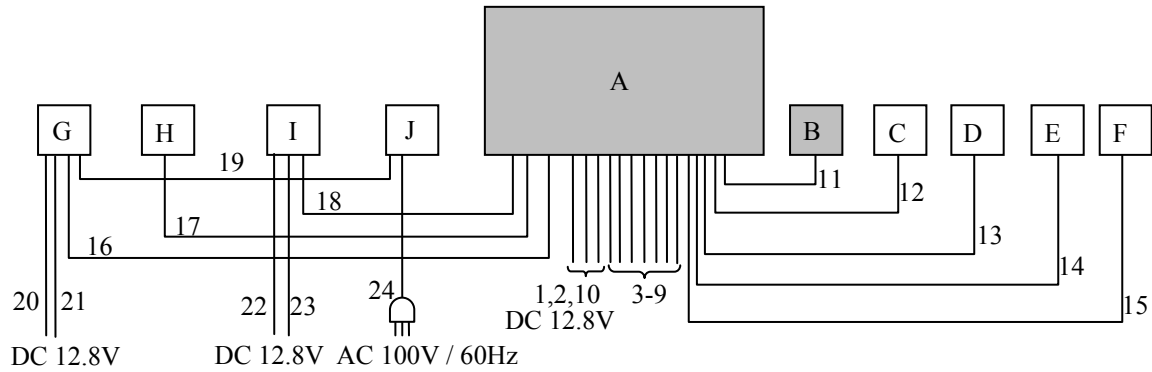

### [Antenna Terminal Conducted Tests]

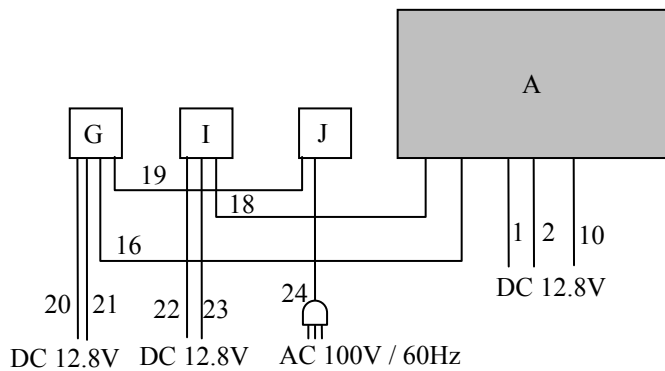

\* Cabling and setup(s) were taken into consideration and test data was taken under worse case conditions.

\* The testing was performed with DC 12.8 V only.

The voltage which the car battery mounted in the car outputs was selected as a test voltage according to the customer's request.

As the stable voltage (DC 3.3 V) is provided to RF module via the internal regulator, it does not influence on the test result.

**UL Japan, Inc.**

**Ise EMC Lab.**

4383-326 Asama-cho, Ise-shi, Mie-ken 516-0021 JAPAN

Telephone : +81 596 24 8999

Facsimile : +81 596 24 8124

**Description of EUT and Support equipment**

No.	Item	Model number	Serial number	Manufacturer	Remarks
A	HEADUNIT A-HIGH	NR-213	No 3-2 for RE* No 3-1 for AT*	mitsubishi electric CORPORATION SANDA WORKS	EUT
B	BT Antenna	050 978-A	38113	WiSi	EUT
C	WLAN Antenna	A2139058402	1234 00012	WiSi	-
D	GPS Antenna	-	-	mitsubishi electric CORPORATION SANDA WORKS	-
E	USB Memory	RFU-2	120301	BUFFALO	-
F	Dummy Load	-	-	mitsubishi electric CORPORATION SANDA WORKS	-
G	HSVL PCB	NTG 5.5 H0H	489	mitsubishi electric CORPORATION SANDA WORKS	-
H	HSVL PCB	NTG 5.5 H0H	487	mitsubishi electric CORPORATION SANDA WORKS	-
I	Controller	A 166 900 10 10	63358850202	Mercedes-Benz	-
J	LCD Monitor	EW2730-B	ETNAB07468SL0	BenQ	-

\* RE: Radiated Spurious Emission / AT: Antenna Terminal Conducted Tests

**List of cables used**

No.	Name	Length (m)	Shield		Remarks
			Cable	Connector	
1	DC Cable (+)	2.0	Unshielded	Unshielded	-
2	DC Cable (-)	2.0	Unshielded	Unshielded	-
3	Dummy Cable (Aux)	1.0	Shielded	Shielded	-
4	Dummy Cable (RUG)	1.0	Shielded	Shielded	-
5	Dummy Cable (Tune 1)	1.0	Shielded	Shielded	-
6	Dummy Cable (Tune 2)	1.0	Shielded	Shielded	-
7	Dummy Cable (Tune 3)	1.0	Shielded	Shielded	-
8	USB Cable 1	1.0	Shielded	Shielded	-
9	USB Cable 2	1.0	Shielded	Shielded	-
10	Main Harness	1.0	Unshielded	Unshielded	-
11	BT Antenna Cable	0.5	Shielded	Shielded	-
12	WLAN Antenna Cable	1.5	Shielded	Shielded	-
13	GPS Antenna Cable	5.0	Shielded	Shielded	-
14	USB Cable 3	1.0	Shielded	Shielded	-
15	Speaker Cable	0.5	Unshielded	Unshielded	-
16	HSLV Cable	1.0	Shielded	Shielded	-
17	HSLV Cable	1.0	Shielded	Shielded	-
18	Controller Cable	2.3	Shielded	Shielded	-
19	DVI Cable	3.0	Shielded	Shielded	-
20	DC Cable (+)	2.0	Shielded	Shielded	-
21	DC Cable (-)	2.0	Unshielded	Unshielded	-
22	DC Cable (+)	2.0	Unshielded	Unshielded	-
23	DC Cable (-)	2.0	Unshielded	Unshielded	-
24	AC Cable	2.0	Unshielded	Unshielded	-

**UL Japan, Inc.  
Ise EMC Lab.**

4383-326 Asama-cho, Ise-shi, Mie-ken 516-0021 JAPAN  
Telephone : +81 596 24 8999  
Facsimile : +81 596 24 8124

## **SECTION 5: Radiated Spurious Emission**

### **Test Procedure**

EUT was placed on a urethane platform of nominal size, 1.0m by 2.0m, raised 0.8m above the conducting ground plane.

The Radiated Electric Field Strength has been measured in a Semi Anechoic Chamber with a ground plane.

The height of the measuring antenna varied between 1 and 4m and EUT was rotated a full revolution in order to obtain the maximum value of the electric field strength.

The measurements were performed for both vertical and horizontal antenna polarization with the Test Receiver, or the Spectrum Analyzer.

The measurements were made with the following detector function of the test receiver and the Spectrum analyzer (in linear mode).

The test was made with the detector (RBW/VBW) in the following table.

When using Spectrum analyzer, the test was made with adjusting span to zero by using peak hold.

### **Test Antennas are used as below;**

Frequency	30MHz to 300MHz	300MHz to 1GHz	Above 1GHz
Antenna Type	Biconical	Logperiodic	Horn

In any 100kHz bandwidth outside the restricted band in which the spread spectrum intentional radiator is operating, the radio frequency power that is produced by the intentional radiator confirmed 20dB below that in the 100kHz bandwidth within the band that contains the highest level of the desired power, based on a radiated measurement.

### **20dBc was applied to the frequency over the limit of FCC 15.209 / Table 4 of RSS-Gen 8.9 (IC) and outside the restricted band of FCC15.205 / Table 6 of RSS-Gen 8.10 (IC).**

Frequency	Below 1GHz	Above 1GHz		20dBc
Instrument used	Test Receiver	Spectrum Analyzer		Spectrum Analyzer
Detector	QP	PK	AV	PK
IF Bandwidth	BW 120kHz	RBW: 1MHz VBW: 3MHz	RBW: 1MHz VBW: 10Hz *1)	RBW: 100kHz VBW: 300kHz
Test Distance	3m	3m (below 10GHz), 1m*2) (above 10GHz)		3m (below 10GHz), 1m*2) (above 10GHz)

\*1) Although 00-705 accepts VBW=10Hz for AV measurements, it was confirmed that superfluous smoothing was not performed.

\*2) Distance Factor:  $20 \times \log(3.0\text{m}/1.0\text{m}) = 9.5\text{dB}$

[BT antenna]

- The carrier level and noise levels were confirmed at each position of X, Y and Z axes of BT antenna to see the position of maximum noise, and the test was made at the position that has the maximum noise.

[HEADUNIT A-HIGH]

-The test was made on EUT at the normal use position.

The test results and limit are rounded off to one decimal place, so some differences might be observed.

**Measurement range** : 30M-25GHz  
**Test data** : APPENDIX  
**Test result** : Pass

**UL Japan, Inc.**

**Ise EMC Lab.**

4383-326 Asama-cho, Ise-shi, Mie-ken 516-0021 JAPAN

Telephone : +81 596 24 8999

Facsimile : +81 596 24 8124

## **SECTION 6: Antenna Terminal Conducted Tests**

### **Test Procedure**

The tests were made with below setting connected to the antenna port.

<b>Test</b>	<b>Span</b>	<b>RBW</b>	<b>VBW</b>	<b>Sweep time</b>	<b>Detector</b>	<b>Trace</b>	<b>Instrument used</b>
20dB Bandwidth	3MHz	30kHz	100kHz	Auto	Peak	Max Hold	Spectrum Analyzer
99% Occupied Bandwidth *1)	Enough width to display emission skirts	1 to 5% of OBW	Three times of RBW	Auto	Peak	Max Hold	Spectrum Analyzer
Maximum Peak Output Power	-	-	-	Auto	Peak / Average *3)	-	Power Meter (Sensor: 50MHz BW)
Carrier Frequency Separation	5MHz or 3MHz	100kHz or 30kHz	300kHz or 100kHz	Auto	Peak	Max Hold	Spectrum Analyzer
Number of Hopping Frequency	30MHz	300kHz	1MHz	Auto	Peak	Max Hold	Spectrum Analyzer
Dwell Time	Zero Span	100kHz, 1MHz	300kHz, 3MHz	As necessary capture the entire dwell time per hopping channel	Peak	Clear Write	Spectrum Analyzer
Conducted Spurious Emission *2)	9kHz to 150kHz	200Hz	620Hz	Auto	Peak	Max Hold	Spectrum Analyzer
	150kHz to 30MHz	9.1kHz	27kHz				
	30MHz to 25GHz (Less or equal to 5GHz)	100kHz	300kHz				
Conducted Spurious Emission Band Edge compliance	10MHz	100kHz	300kHz	Auto	Peak	Max Hold	Spectrum Analyzer

\*1) Peak hold was applied as Worst-case measurement.  
\*2) In the frequency range below 30MHz, RBW was narrowed to separate the noise contents. Then, wide-band noise near the limit was checked separately, however the noise was not detected as shown in the chart.(9kHz-150kHz:RBW=200Hz, 150kHz-30MHz:RBW=9.1kHz)  
\*3) Reference data

The test results and limit are rounded off to two decimals place, so some differences might be observed.

**Test data** : APPENDIX  
**Test result** : Pass

**UL Japan, Inc.**  
**Ise EMC Lab.**

4383-326 Asama-cho, Ise-shi, Mie-ken 516-0021 JAPAN  
Telephone : +81 596 24 8999  
Facsimile : +81 596 24 8124

**APPENDIX 1: Data of EMI test**

**20dB Bandwidth and Carrier Frequency Separation**

Test place	Ise EMC Lab. No.11 Measurement Room
Report No.	10607274H
Date	03/10/2015
Temperature/ Humidity	21deg. C / 30% RH
Engineer	Keisuke Kawamura
Mode	Tx (Hopping on/off) DH5/3DH5/Inquiry

Mode	Freq. [MHz]	20dB Bandwidth [MHz]	Carrier Frequency Separation [MHz]	Limit for Carrier Frequency separation [MHz]
DH5	2402.0	0.956	1.000	≧ 0.637
DH5	2441.0	0.959	1.000	≧ 0.639
DH5	2480.0	0.934	1.000	≧ 0.623
3DH5	2402.0	1.316	1.000	≧ 0.877
3DH5	2441.0	1.302	1.000	≧ 0.868
3DH5	2480.0	1.316	1.000	≧ 0.877
Inquiry	2441.0	0.805	2.000	≧ 0.537

Limit: Two-thirds of 20dB Bandwidth or 25kHz (whichever is greater).  
No limit applies to 20dB Bandwidth.

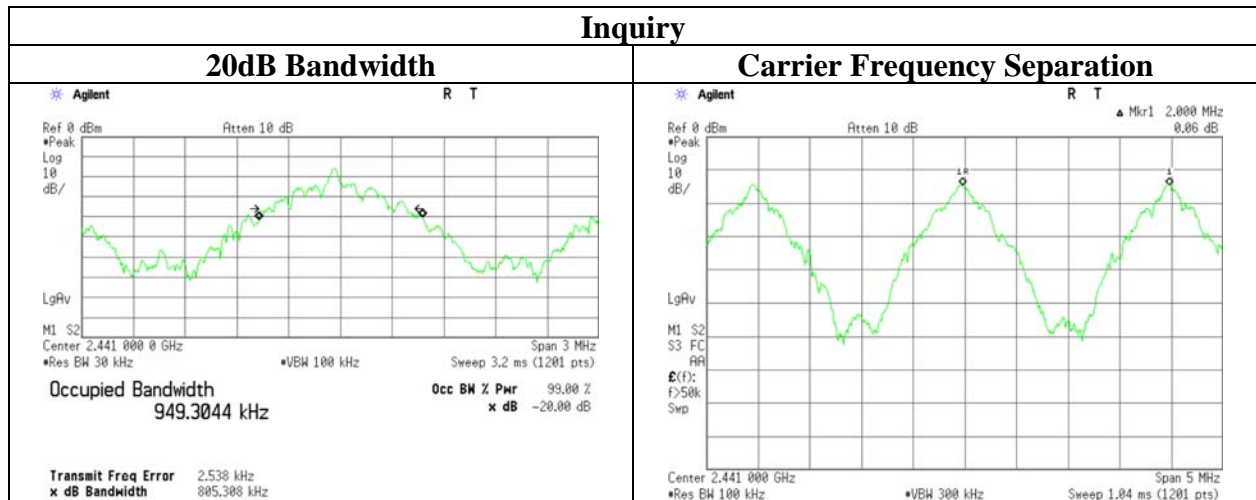

**UL Japan, Inc.**  
**Ise EMC Lab.**

4383-326 Asama-cho, Ise-shi, Mie-ken 516-0021 JAPAN  
Telephone : +81 596 24 8999  
Facsimile : +81 596 24 8124

**20dB Bandwidth and Carrier Frequency Separation**

<b>Tx DH5</b>	
<b>20dB Bandwidth</b>	<b>Carrier Frequency Separation</b>
<b>2402MHz</b>	<b>2402MHz</b>
<p>Agilent R T</p> <p>Ref 107 dBμV *Atten 10 dB</p> <p>Center 2.402 000 0 GHz Span 3 MHz      *Res BW 30 kHz *VBW 100 kHz Sweep 3.2 ms (1201 pts)</p> <p><b>Occupied Bandwidth</b> 870.3733 kHz  <b>Occ BW % Pwr</b> 99.00 %  <b>x dB</b> -20.00 dB</p> <p><b>Transmit Freq Error</b> -6.856 kHz  <b>x dB Bandwidth</b> 956.323 kHz</p>	<p>Agilent R T</p> <p>Ref 0 dBm *Atten 10 dB</p> <p>Center 2.403 000 0 GHz Span 3 MHz      *Res BW 30 kHz *VBW 100 kHz Sweep 3.2 ms (1201 pts)</p> <p>Mkr1 1.000 0 MHz 0.27 dB</p>
<b>2441MHz</b>	<b>2441MHz</b>
<p>Agilent R T</p> <p>Ref 107 dBμV *Atten 10 dB</p> <p>Center 2.441 000 0 GHz Span 3 MHz      *Res BW 30 kHz *VBW 100 kHz Sweep 3.2 ms (1201 pts)</p> <p><b>Occupied Bandwidth</b> 863.4966 kHz  <b>Occ BW % Pwr</b> 99.00 %  <b>x dB</b> -20.00 dB</p> <p><b>Transmit Freq Error</b> -10.421 kHz  <b>x dB Bandwidth</b> 959.461 kHz</p>	<p>Agilent R T</p> <p>Ref 0 dBm *Atten 10 dB</p> <p>Center 2.441 000 0 GHz Span 3 MHz      *Res BW 30 kHz *VBW 100 kHz Sweep 3.2 ms (1201 pts)</p> <p>Mkr1 1.000 0 MHz -0.39 dB</p>
<b>2480MHz</b>	<b>2480MHz</b>
<p>Agilent R T</p> <p>Ref 107 dBμV *Atten 10 dB</p> <p>Center 2.480 000 0 GHz Span 3 MHz      *Res BW 30 kHz *VBW 100 kHz Sweep 3.2 ms (1201 pts)</p> <p><b>Occupied Bandwidth</b> 860.6853 kHz  <b>Occ BW % Pwr</b> 99.00 %  <b>x dB</b> -20.00 dB</p> <p><b>Transmit Freq Error</b> -15.607 kHz  <b>x dB Bandwidth</b> 933.883 kHz</p>	<p>Agilent R T</p> <p>Ref 0 dBm *Atten 10 dB</p> <p>Center 2.479 000 0 GHz Span 3 MHz      *Res BW 30 kHz *VBW 100 kHz Sweep 3.2 ms (1201 pts)</p> <p>Mkr1 1.000 0 MHz 0.58 dB</p>

**UL Japan, Inc.**  
**Ise EMC Lab.**

4383-326 Asama-cho, Ise-shi, Mie-ken 516-0021 JAPAN  
 Telephone : +81 596 24 8999  
 Facsimile : +81 596 24 8124

**20dB Bandwidth and Carrier Frequency Separation**

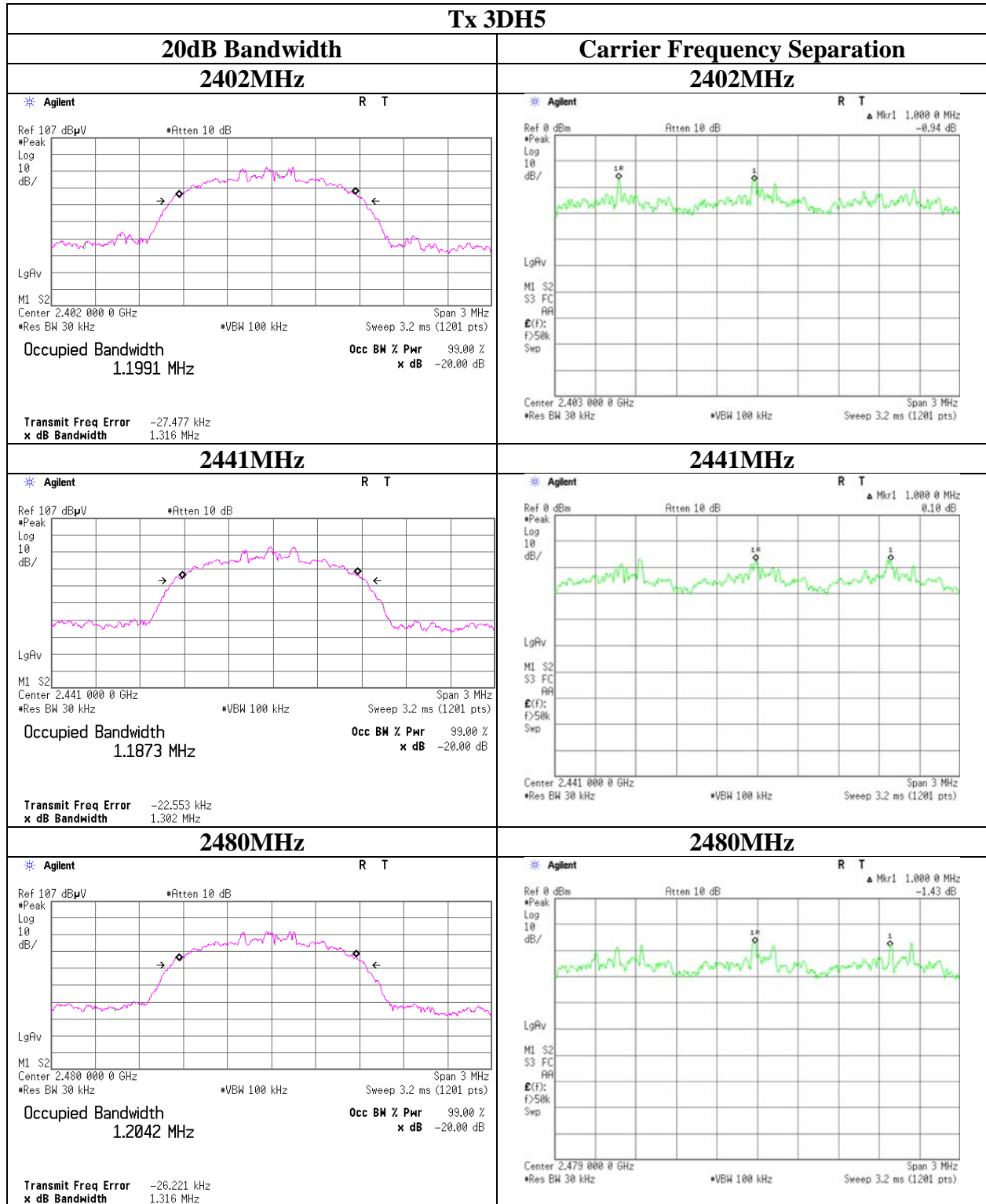

## Number of Hopping Frequency

Test place	Ise EMC Lab. No.11 Measurement Room
Report No.	10607274H
Date	03/06/2015
Temperature/ Humidity	21deg. C / 30% RH
Engineer	Tsubasa Takayama
Mode	Tx (Hopping on) DH5/3DH5/Inquiry

Mode	Number of channel [times]	Limit [times]
DH5	79	>= 15
3DH5	79	>= 15
Inquiry	32	>= 15

Test was not performed at AFH mode whose number of hopping channel is 20 channels because this Bluetooth radio is in compliance of Bluetooth Specification.

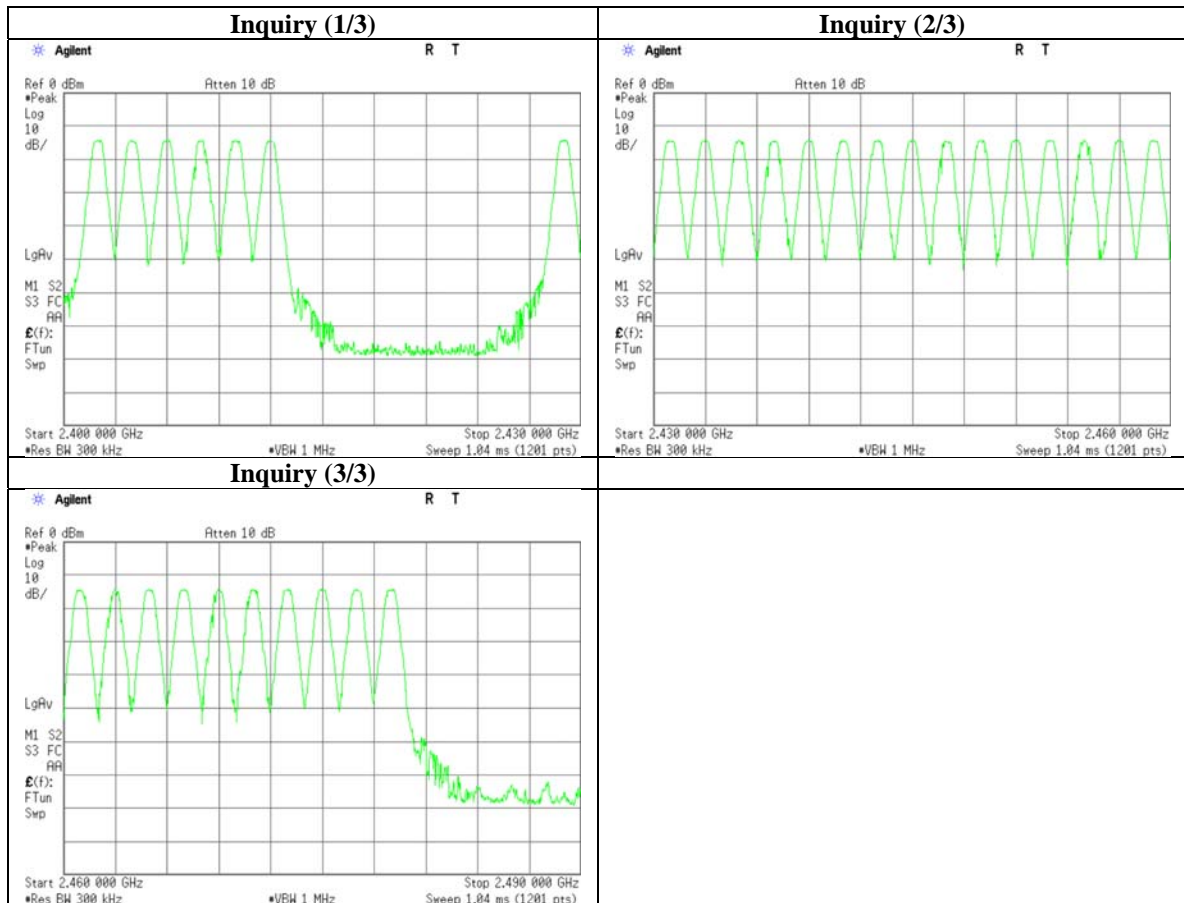



**Number of Hopping Frequency**

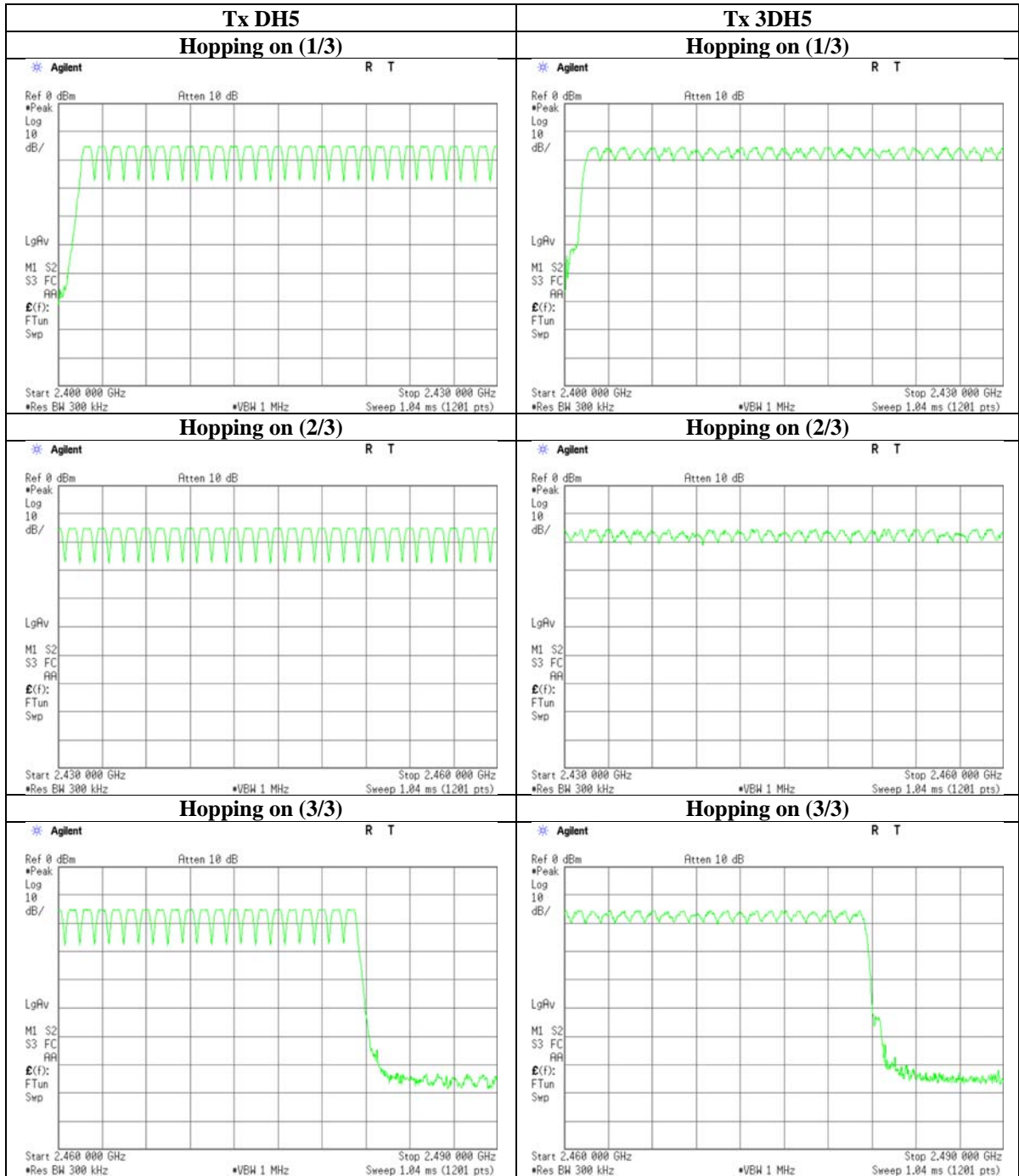

## Dwell time

Test place	Ise EMC Lab. No.11 Measurement Room
Report No.	10607274H
Date	03/06/2015
Temperature/ Humidity	23deg. C / 32% RH
Engineer	Tsubasa Takayama
Mode	Tx (Hopping on) DH5/3DH5/Inquiry

Mode	Number of transmission in a 31.6(79 Hopping x 0.4) / 12.8(32 Hopping x 0.4)second period	Length of transmission time [msec]	Result [msec]	Limit [msec]
DH1	51.0 times / 5 sec. x 31.6 sec. = 323 times	0.413	133	400
DH3	25.4 times / 5 sec. x 31.6 sec. = 161 times	1.676	270	400
DH5	17.0 times / 5 sec. x 31.6 sec. = 108 times	2.920	315	400
3DH1	50.6 times / 5 sec. x 31.6 sec. = 320 times	0.426	136	400
3DH3	25.8 times / 5 sec. x 31.6 sec. = 164 times	1.686	277	400
3DH5	16.8 times / 5 sec. x 31.6 sec. = 107 times	2.940	315	400
Inquiry	100.0 times / 1 sec. x 12.8 sec. = 1280 times	0.111	142	400

Sample Calculation

Result = Number of transmission x Length of transmission time

\*Average data of 5 tests.(except Inquiry)

Mode	Sampling [times]					Average [times]
	1	2	3	4	5	
DH1	51	51	51	51	51	51
DH3	25	25	26	25	26	25.4
DH5	17	17	17	17	17	17
3DH1	51	51	50	50	51	50.6
3DH3	25	26	26	26	26	25.8
3DH5	16	17	17	17	17	16.8

Sample Calculation

Average= Summation(Sampling 1 to 5) / 5

This device complies with the Bluetooth protocol for FHSS operation, employing a pseudo random channel selection and hopping rate to ensure that the occupancy time in  $N \times 0.4s$ , where  $N$  is the number of channels being used in the hopping sequence ( $20 \leq N \leq 79$ ), is always less than 0.4s regardless of packet size. This is confirmed in the test report for  $N=79$ .

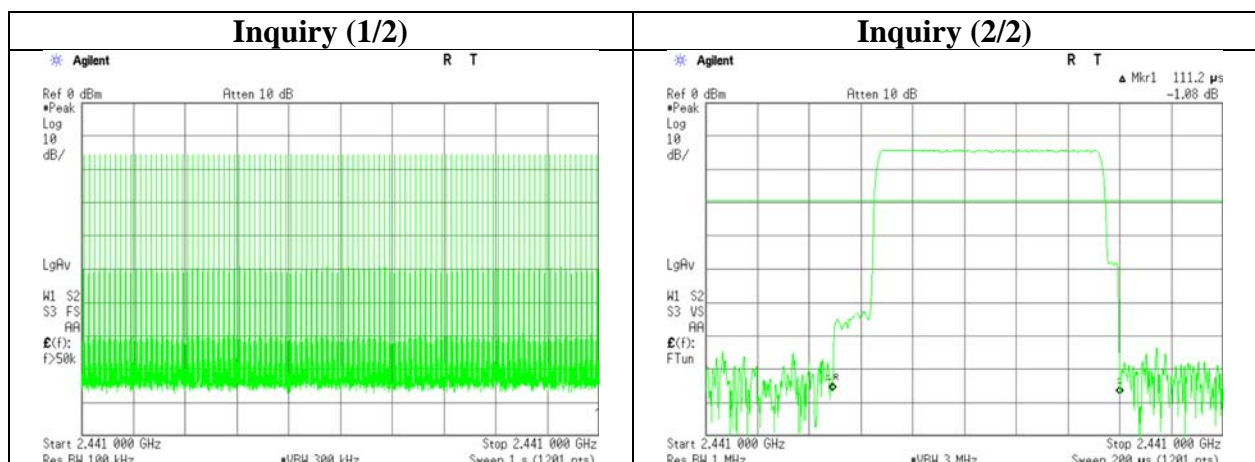

**UL Japan, Inc.**

**Ise EMC Lab.**

4383-326 Asama-cho, Ise-shi, Mie-ken 516-0021 JAPAN

Telephone : +81 596 24 8999

Facsimile : +81 596 24 8124

**Dwell time**

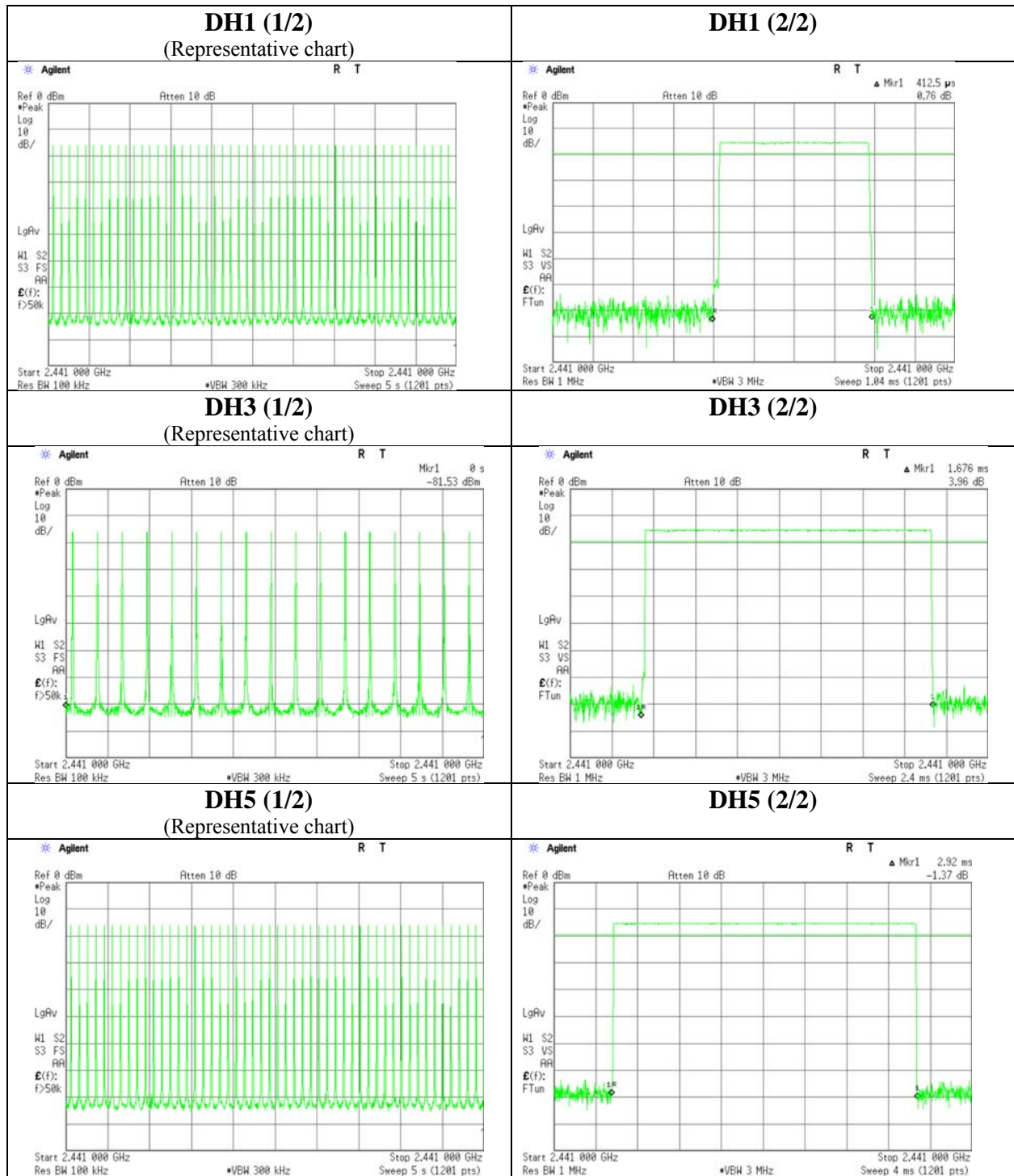

**UL Japan, Inc.**  
**Ise EMC Lab.**

4383-326 Asama-cho, Ise-shi, Mie-ken 516-0021 JAPAN  
 Telephone : +81 596 24 8999  
 Facsimile : +81 596 24 8124

**Dwell time**

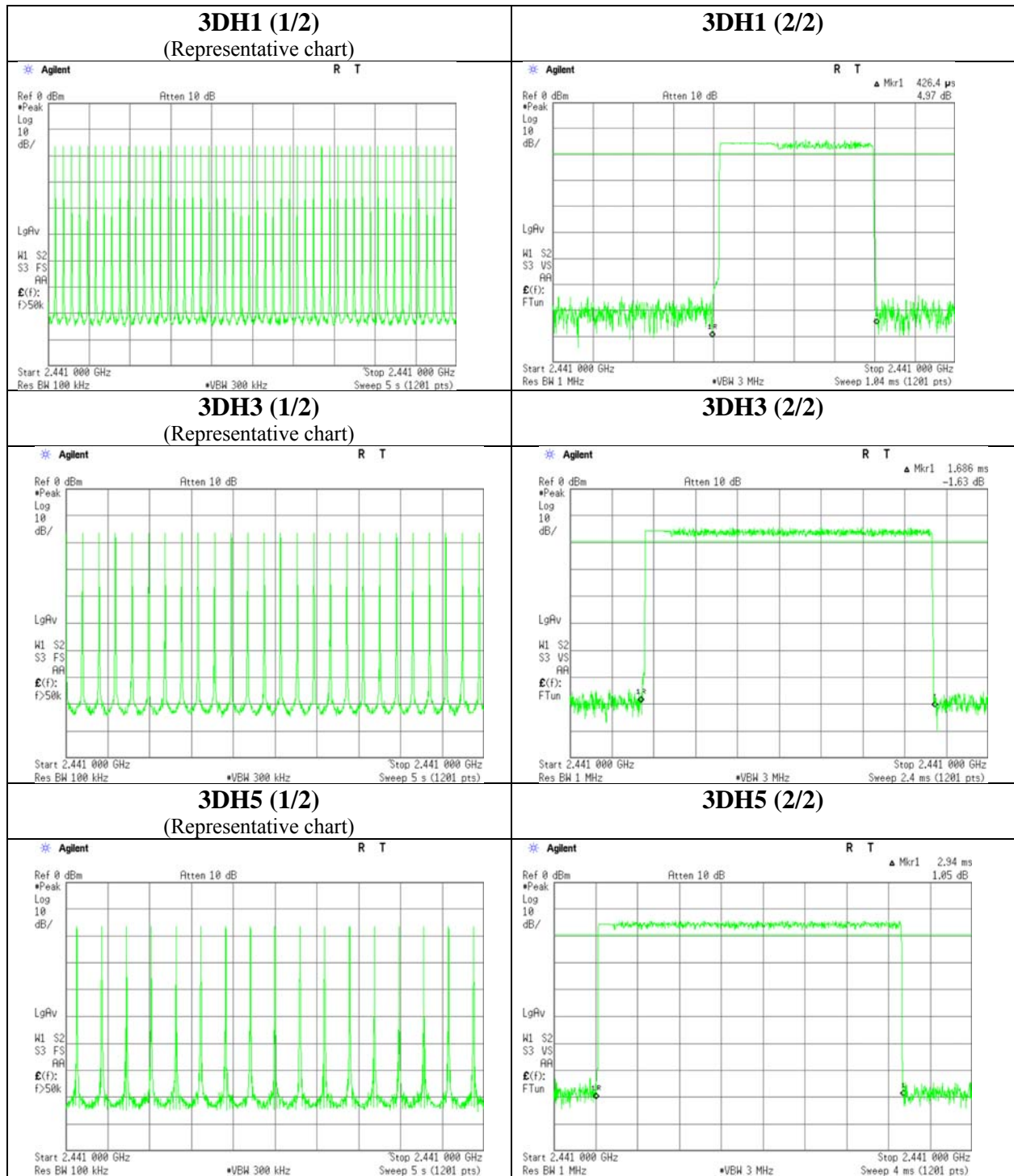

**UL Japan, Inc.**  
**Ise EMC Lab.**

4383-326 Asama-cho, Ise-shi, Mie-ken 516-0021 JAPAN  
 Telephone : +81 596 24 8999  
 Facsimile : +81 596 24 8124

## Maximum Peak Output Power

Test place : Ise EMC Lab. No.11 Measurement Room  
Report No. : 10607274H  
Date : 02/27/2015  
Temperature/ Humidity : 21deg. C / 30% RH  
Engineer : Tsubasa Takayama  
Mode : Tx (Hopping off) DH5/2DH5/3DH5/Inquiry

Mode	Freq. [MHz]	Reading [dBm]	Cable Loss [dB]	Atten. [dB]	Result		Limit		Margin [dB]
					[dBm]	[mW]	[dBm]	[mW]	
DH5	2402.0	-14.79	2.31	10.08	-2.40	0.58	20.96	125	23.36
DH5	2441.0	-14.67	2.32	10.08	-2.27	0.59	20.96	125	23.23
DH5	2480.0	-15.51	2.33	10.08	-3.10	0.49	20.96	125	24.06
2DH5	2402.0	-15.58	2.31	10.08	-3.19	0.48	20.96	125	24.15
2DH5	2441.0	-14.93	2.32	10.08	-2.53	0.56	20.96	125	23.49
2DH5	2480.0	-15.22	2.33	10.08	-2.81	0.52	20.96	125	23.77
3DH5	2402.0	-14.51	2.31	10.08	-2.12	0.61	20.96	125	23.08
3DH5	2441.0	-13.96	2.32	10.08	-1.56	0.70	20.96	125	22.52
3DH5	2480.0	-14.80	2.33	10.08	-2.39	0.58	20.96	125	23.35
Inquiry	2441.0	-15.49	2.32	10.08	-3.09	0.49	20.96	125	24.05

Sample Calculation:

Result = Reading + Cable Loss (including the cable(s) customer supplied) + Attenuator

Test was not performed at AFH mode, because the decrease of number of channel (min: 20ch) at AFH mode does not influence on the output power and bandwidth of the EUT.

As this device had AFH mode and frequency separation could not meet the requirement of over 20dB BW without 2/3 relaxation, 125mW power limit was applied to it.

**UL Japan, Inc.**

**Ise EMC Lab.**

4383-326 Asama-cho, Ise-shi, Mie-ken 516-0021 JAPAN

Telephone : +81 596 24 8999

Facsimile : +81 596 24 8124

**Average Output Power**  
**(Reference data for RF Exposure)**

Test place : Ise EMC Lab. No.11 Measurement Room  
Report No. : 10607274H  
Date : 02/27/2015  
Temperature/ Humidity : 21deg. C / 30% RH  
Engineer : Tsubasa Takayama  
Mode : Tx (Hopping off) DH5/2DH5/3DH5

Mode	Freq. [MHz]	Reading [dBm]	Cable Loss [dB]	Atten. [dB]	Result	
					[dBm]	[mW]
DH5	2402.0	-16.95	2.31	10.08	-4.56	0.35
DH5	2441.0	-18.42	2.32	10.08	-6.02	0.25
DH5	2480.0	-17.26	2.33	10.08	-4.85	0.33
2DH5	2402.0	-18.06	2.31	10.08	-5.67	0.27
2DH5	2441.0	-18.49	2.32	10.08	-6.09	0.25
2DH5	2480.0	-18.81	2.33	10.08	-6.40	0.23
3DH5	2402.0	-18.02	2.31	10.08	-5.63	0.27
3DH5	2441.0	-18.00	2.32	10.08	-5.60	0.28
3DH5	2480.0	-18.32	2.33	10.08	-5.91	0.26

Sample Calculation:

Result = Reading + Cable Loss (including the cable(s) customer supplied)+ Attenuator

**UL Japan, Inc.**

**Ise EMC Lab.**

4383-326 Asama-cho, Ise-shi, Mie-ken 516-0021 JAPAN

Telephone : +81 596 24 8999

Facsimile : +81 596 24 8124



## Radiated Spurious Emission

Test place : Ise EMC Lab. No.3 Semi Anechoic Chamber  
Report No. : 10607274H  
Date : 03/02/2015  
Temperature/ Humidity : 23deg. C / 39% RH  
Engineer : Koji Yamamoto  
(1-10GHz)  
Mode : Tx, DH5 2402MHz

**20dBc Data Sheet**

Polarity	Frequency [MHz]	Detector	Reading [dBuV]	Ant Factor [dB/m]	Loss [dB]	Gain [dB]	Result [dBuV/m]	Limit dBuV/m	Margin [dB]	Remark
Hori	2402.000	PK	98.9	26.8	3.2	32.7	96.2	-	-	Carrier
Hori	2400.000	PK	46.4	26.8	3.2	32.7	43.7	76.2	32.5	
Vert	2402.000	PK	100.4	26.8	3.2	32.7	97.7	-	-	Carrier
Vert	2400.000	PK	46.2	26.8	3.2	32.7	43.5	77.7	34.2	

Result = Reading + Ant Factor + Loss (Cable+Attenuator+Filter-Distance factor(above 10GHz)) - Gain(Amplifier)

**UL Japan, Inc.**

**Ise EMC Lab.**

4383-326 Asama-cho, Ise-shi, Mie-ken 516-0021 JAPAN

Telephone : +81 596 24 8999

Facsimile : +81 596 24 8124



## Radiated Spurious Emission

Test place	Ise EMC Lab. No.3 Semi Anechoic Chamber		
Report No.	10607274H		
Date	03/02/2015	03/04/2015	03/09/2015
Temperature/ Humidity	23deg. C / 39% RH	25deg. C / 39% RH	23deg. C / 34% RH
Engineer	Takafumi Noguchi (1-10GHz)	Takafumi Noguchi (10-26.5GHz)	Tsubasa Takayama (Below 1GHz)
Mode	Tx, DH5 2441MHz		

Polarity	Frequency [MHz]	Detector	Reading [dBuV]	Ant.Fac. [dB/m]	Loss [dB]	Gain [dB]	Result [dBuV/m]	Limit [dBuV/m]	Margin [dB]	Remark
Hori	77.683	QP	36.3	6.3	7.8	32.1	18.3	40.0	21.7	
Hori	146.253	QP	35.2	14.7	8.6	32.1	26.4	43.5	17.1	
Hori	243.749	QP	32.2	17.1	9.4	32.0	26.7	46.0	19.3	
Hori	374.976	QP	31.2	16.9	10.4	31.9	26.6	46.0	19.4	
Hori	627.167	QP	35.2	19.7	12.0	32.0	34.9	46.0	11.1	
Hori	983.016	QP	40.2	23.3	13.6	30.5	46.6	53.9	7.3	
Hori	1757.070	PK	61.2	25.8	2.7	33.4	56.3	73.9	17.6	
Hori	1836.000	PK	61.6	25.9	2.9	33.3	57.1	73.9	16.8	
Hori	2499.935	PK	56.2	26.9	3.2	32.7	53.6	73.9	20.3	
Hori	3132.250	PK	49.1	27.5	3.6	32.4	47.8	73.9	26.1	
Hori	4882.000	PK	45.3	30.8	4.4	31.7	48.8	73.9	25.1	
Hori	7323.000	PK	47.8	35.9	5.6	32.7	56.6	73.9	17.3	
Hori	8198.671	PK	47.8	37.1	5.8	32.9	57.8	73.9	16.1	
Hori	9764.000	PK	42.2	38.7	6.5	33.4	54.0	73.9	19.9	Floor Noise
Hori	1757.070	AV	50.4	25.8	2.7	33.4	45.5	53.9	8.4	
Hori	1836.000	AV	51.7	25.9	2.9	33.3	47.2	53.9	6.7	
Hori	2499.935	AV	54.4	26.9	3.2	32.7	51.8	53.9	2.1	
Hori	3132.250	AV	44.3	27.5	3.6	32.4	43.0	53.9	10.9	
Hori	4882.000	AV	35.8	30.8	4.4	31.7	39.3	53.9	14.6	
Hori	7323.000	AV	37.3	35.9	5.6	32.7	46.1	53.9	7.8	
Hori	8198.671	AV	43.0	37.1	5.8	32.9	53.0	53.9	0.9	
Hori	9764.000	AV	30.4	38.7	6.5	33.4	42.2	53.9	11.7	Floor Noise
Vert	79.472	QP	41.1	6.3	7.8	32.1	23.1	40.0	16.9	
Vert	108.000	QP	34.2	11.3	8.1	32.1	21.5	43.5	22.0	
Vert	146.253	QP	38.1	14.7	8.6	32.1	29.3	43.5	14.2	
Vert	243.749	QP	35.0	17.1	9.4	32.0	29.5	46.0	16.5	
Vert	276.000	QP	32.2	18.6	9.8	31.9	28.7	46.0	17.3	
Vert	375.000	QP	32.0	16.9	10.4	31.9	27.4	46.0	18.6	
Vert	627.177	QP	33.2	19.7	12.0	32.0	32.9	46.0	13.1	
Vert	719.949	QP	31.0	20.8	12.4	31.9	32.3	46.0	13.7	
Vert	983.016	QP	36.9	23.3	13.6	30.5	43.3	53.9	10.6	
Vert	1749.830	PK	64.7	25.8	2.7	33.4	59.8	73.9	14.1	
Vert	1844.671	PK	65.8	25.9	2.9	33.2	61.4	73.9	12.5	
Vert	2499.935	PK	54.7	26.9	3.2	32.7	52.1	73.9	21.8	
Vert	3132.344	PK	52.6	27.5	3.6	32.4	51.3	73.9	22.6	
Vert	4882.000	PK	45.6	30.8	5.3	31.7	50.0	73.9	23.9	
Vert	7323.000	PK	48.9	35.9	6.5	32.7	58.6	73.9	15.3	
Vert	8195.667	PK	47.9	37.1	5.8	32.9	57.9	73.9	16.0	
Vert	9764.000	PK	42.3	38.7	7.1	33.4	54.7	73.9	19.2	Floor Noise
Vert	1749.830	AV	53.7	25.8	2.7	33.4	48.8	53.9	5.1	
Vert	1844.671	AV	54.4	25.9	2.9	33.2	50.0	53.9	3.9	
Vert	2499.935	AV	52.3	26.9	3.2	32.7	49.7	53.9	4.2	
Vert	3132.344	AV	49.8	27.5	3.6	32.4	48.5	53.9	5.4	
Vert	4882.000	AV	37.2	30.8	5.3	31.7	41.6	53.9	12.3	
Vert	7323.000	AV	40.4	35.9	6.5	32.7	50.1	53.9	3.8	
Vert	8195.667	AV	43.1	37.1	5.8	32.9	53.1	53.9	0.8	
Vert	9764.000	AV	30.3	38.7	7.1	33.4	42.7	53.9	11.2	Floor Noise

Result = Reading + Ant Factor + Loss (Cable+Attenuator+Filter-Distance factor(above 10GHz)) - Gain(Amplifier)

\*Other frequency noises omitted in this report were not seen or had enough margin (more than 20dB).

\*The 10th harmonic was not seen so the result was its base noise level.

Distance factor: 10GHz-26.5GHz 20log(3.0m/1.0m)= 9.5dB

## Radiated Spurious Emission

Test place Ise EMC Lab. No.3 Semi Anechoic Chamber  
Report No. 10607274H  
Date 03/02/2015 03/04/2015 03/09/2015  
Temperature/ Humidity 23deg. C / 39% RH 25deg. C / 39% RH 23deg. C / 34% RH  
Engineer Takafumi Noguchi Takafumi Noguchi Tsubasa Takayama  
(1-10GHz) (10-26.5GHz) (Below 1GHz)  
Mode Tx, DH5 2480MHz

Polarity	Frequency [MHz]	Detector	Reading [dBuV]	Ant.Fac. [dB/m]	Loss [dB]	Gain [dB]	Result [dBuV/m]	Limit [dBuV/m]	Margin [dB]	Remark
Hori	77.271	QP	36.4	6.3	7.8	32.1	18.4	40.0	21.6	
Hori	146.253	QP	35.1	14.7	8.6	32.1	26.3	43.5	17.2	
Hori	243.749	QP	31.8	17.1	9.4	32.0	26.3	46.0	19.7	
Hori	374.976	QP	32.0	16.9	10.4	31.9	27.4	46.0	18.6	
Hori	627.167	QP	35.1	19.7	12.0	32.0	34.8	46.0	11.2	
Hori	983.016	QP	40.0	23.3	13.6	30.5	46.4	53.9	7.5	
Hori	1754.329	PK	60.4	25.8	2.7	33.4	55.5	73.9	18.4	
Hori	1836.000	PK	61.1	25.9	2.9	33.3	56.6	73.9	17.3	
Hori	2483.500	PK	47.6	26.9	3.2	32.7	45.0	73.9	28.9	
Hori	2499.883	PK	55.7	26.9	3.2	32.7	53.1	73.9	20.8	
Hori	3132.316	PK	49.0	27.5	3.6	32.4	47.7	73.9	26.2	
Hori	4960.000	PK	44.5	30.9	5.2	31.7	48.9	73.9	25.0	
Hori	7440.000	PK	43.5	35.9	6.6	32.7	53.3	73.9	20.6	
Hori	8195.917	PK	47.4	37.1	5.8	32.9	57.4	73.9	16.5	
Hori	9920.000	PK	41.4	38.9	7.1	33.5	53.9	73.9	20.0	Floor Noise
Hori	1754.329	AV	49.2	25.8	2.7	33.4	44.3	53.9	9.6	
Hori	1836.000	AV	52.3	25.9	2.9	33.3	47.8	53.9	6.1	
Hori	2483.500	AV	32.2	26.9	3.2	32.7	29.6	53.9	24.3	
Hori	2499.883	AV	53.7	26.9	3.2	32.7	51.1	53.9	2.8	
Hori	3132.316	AV	44.3	27.5	3.6	32.4	43.0	53.9	10.9	
Hori	4960.000	AV	33.9	30.9	5.2	31.7	38.3	53.9	15.6	
Hori	7440.000	AV	32.2	35.9	6.6	32.7	42.0	53.9	11.9	
Hori	8195.917	AV	43.0	37.1	5.8	32.9	53.0	53.9	0.9	
Hori	9920.000	AV	28.8	38.9	7.1	33.5	41.3	53.9	12.6	Floor Noise
Vert	79.481	QP	41.0	6.3	7.8	32.1	23.0	40.0	17.0	
Vert	108.000	QP	34.2	11.3	8.1	32.1	21.5	43.5	22.0	
Vert	146.253	QP	38.0	14.7	8.6	32.1	29.2	43.5	14.3	
Vert	243.749	QP	35.2	17.1	9.4	32.0	29.7	46.0	16.3	
Vert	276.000	QP	32.1	18.6	9.8	31.9	28.6	46.0	17.4	
Vert	375.000	QP	32.0	16.9	10.4	31.9	27.4	46.0	18.6	
Vert	627.177	QP	33.1	19.7	12.0	32.0	32.8	46.0	13.2	
Vert	719.949	QP	31.2	20.8	12.4	31.9	32.5	46.0	13.5	
Vert	983.016	QP	37.0	23.3	13.6	30.5	43.4	53.9	10.5	
Vert	1747.630	PK	63.0	25.8	2.7	33.4	58.1	73.9	15.8	
Vert	1844.670	PK	62.7	25.9	2.9	33.2	58.3	73.9	15.6	
Vert	2483.500	PK	49.9	26.9	3.2	32.7	47.3	73.9	26.6	
Vert	2499.877	PK	53.7	26.9	3.2	32.7	51.1	73.9	22.8	
Vert	3132.315	PK	53.0	27.5	3.6	32.4	51.7	73.9	22.2	
Vert	4960.000	PK	44.8	30.9	5.2	31.7	49.2	73.9	24.7	
Vert	7440.000	PK	45.8	35.9	6.6	32.7	55.6	73.9	18.3	
Vert	8198.670	PK	49.1	37.1	5.8	32.9	59.1	73.9	14.8	
Vert	9920.000	PK	41.1	38.9	7.1	33.5	53.6	73.9	20.3	Floor Noise
Vert	1747.630	AV	52.7	25.8	2.7	33.4	47.8	53.9	6.1	
Vert	1844.670	AV	51.7	25.9	2.9	33.2	47.3	53.9	6.6	
Vert	2483.500	AV	33.5	26.9	3.2	32.7	30.9	53.9	23.0	
Vert	2499.877	AV	51.3	26.9	3.2	32.7	48.7	53.9	5.2	
Vert	3132.315	AV	50.1	27.5	3.6	32.4	48.8	53.9	5.1	
Vert	4960.000	AV	36.4	30.9	5.2	31.7	40.8	53.9	13.1	
Vert	7440.000	AV	35.8	35.9	6.6	32.7	45.6	53.9	8.3	
Vert	8198.670	AV	43.0	37.1	5.8	32.9	53.0	53.9	0.9	
Vert	9920.000	AV	30.2	38.9	7.1	33.5	42.7	53.9	11.2	Floor Noise

Result = Reading + Ant Factor + Loss (Cable+Attenuator+Filter-Distance factor(above 10GHz)) - Gain(Amplifier)

\*Other frequency noises omitted in this report were not seen or had enough margin (more than 20dB).

\*The 10th harmonic was not seen so the result was its base noise level.

Distance factor: 10GHz-26.5GHz 20log(3.0m/1.0m)= 9.5dB

## Radiated Spurious Emission

Test place	Ise EMC Lab. No.3 Semi Anechoic Chamber		
Report No.	10607274H		
Date	03/02/2015	03/04/2015	03/11/2015
Temperature/ Humidity	23deg. C / 39% RH	25deg. C / 39% RH	20deg. C / 29% RH
Engineer	Takafumi Noguchi	Takafumi Noguchi	Takafumi Noguchi
	(1-10GHz)	(10-26.5GHz)	(Below 1GHz)
Mode	Tx, 3DH5 2402MHz		

Polarity	Frequency [MHz]	Detector	Reading [dBuV]	Ant.Fac. [dB/m]	Loss [dB]	Gain [dB]	Result [dBuV/m]	Limit [dBuV/m]	Margin [dB]	Remark
Hori	78.126	QP	36.9	6.3	7.8	32.0	19.0	40.0	21.0	
Hori	146.254	QP	37.5	14.7	8.6	32.2	28.6	43.5	14.9	
Hori	243.755	QP	37.4	17.1	9.4	32.1	31.8	46.0	14.2	
Hori	276.013	QP	32.2	18.6	9.8	32.0	28.6	46.0	17.4	
Hori	341.257	QP	32.7	16.0	10.2	32.0	26.9	46.0	19.1	
Hori	390.001	QP	31.1	17.3	10.5	32.0	26.9	46.0	19.1	
Hori	627.168	QP	33.9	19.7	12.0	32.1	33.5	46.0	12.5	
Hori	719.970	QP	27.7	20.8	12.4	32.0	28.9	46.0	17.1	
Hori	866.278	QP	30.8	22.4	13.1	31.2	35.1	46.0	10.9	
Hori	959.952	QP	29.6	23.1	13.5	30.7	35.5	46.0	10.5	
Hori	983.011	QP	37.3	23.3	13.6	30.6	43.6	53.9	10.3	
Hori	1756.717	PK	62.2	25.8	2.7	33.4	57.3	73.9	16.6	
Hori	1844.500	PK	57.6	25.9	2.9	33.2	53.2	73.9	20.7	
Hori	2390.000	PK	47.2	26.8	3.2	32.7	44.5	73.9	29.4	
Hori	3132.257	PK	49.0	27.5	3.6	32.4	47.7	73.9	26.2	
Hori	4804.000	PK	45.1	30.6	5.2	31.8	49.1	73.9	24.8	
Hori	7206.000	PK	42.2	35.9	6.6	32.7	52.0	73.9	21.9	Floor Noise
Hori	8196.630	PK	47.1	37.1	5.8	32.9	57.1	73.9	16.8	
Hori	9608.000	PK	42.3	38.4	7.0	33.3	54.4	73.9	19.5	Floor Noise
Hori	1756.717	AV	50.4	25.8	2.7	33.4	45.5	53.9	8.4	
Hori	1844.500	AV	50.6	25.9	2.9	33.2	46.2	53.9	7.7	
Hori	2390.000	AV	31.5	26.8	3.2	32.7	28.8	53.9	25.1	
Hori	3132.257	AV	44.4	27.5	3.6	32.4	43.1	53.9	10.8	
Hori	4804.000	AV	34.4	30.6	5.2	31.8	38.4	53.9	15.5	
Hori	7206.000	AV	30.9	35.9	6.6	32.7	40.7	53.9	13.2	Floor Noise
Hori	8196.630	AV	43.1	37.1	5.8	32.9	53.1	53.9	0.8	
Hori	9608.000	AV	30.6	38.4	7.0	33.3	42.7	53.9	11.2	Floor Noise
Vert	78.379	QP	42.9	6.3	7.8	32.0	25.0	40.0	15.0	
Vert	146.249	QP	35.1	14.7	8.6	32.2	26.2	43.5	17.3	
Vert	243.750	QP	33.2	17.1	9.4	32.1	27.6	46.0	18.4	
Vert	276.007	QP	34.9	18.6	9.8	32.0	31.3	46.0	14.7	
Vert	341.251	QP	29.7	16.0	10.2	32.0	23.9	46.0	22.1	
Vert	390.000	QP	28.3	17.3	10.5	32.0	24.1	46.0	21.9	
Vert	719.962	QP	31.8	20.8	12.4	32.0	33.0	46.0	13.0	
Vert	863.652	QP	29.9	22.4	13.0	31.2	34.1	46.0	11.9	
Vert	959.949	QP	30.1	23.1	13.5	30.7	36.0	46.0	10.0	
Vert	983.011	QP	36.6	23.3	13.6	30.6	42.9	53.9	11.0	
Vert	1754.258	PK	63.5	25.8	2.7	33.4	58.6	73.9	15.3	
Vert	1844.170	PK	64.9	25.9	2.9	33.2	60.5	73.9	13.4	
Vert	2390.000	PK	48.2	26.8	3.2	32.7	45.5	73.9	28.4	
Vert	3132.337	PK	52.3	27.5	3.6	32.4	51.0	73.9	22.9	
Vert	4804.000	PK	45.2	30.6	5.2	31.8	49.2	73.9	24.7	
Vert	7206.000	PK	43.8	35.9	6.6	32.7	53.6	73.9	20.3	
Vert	8194.600	PK	49.5	37.1	5.8	32.9	59.5	73.9	14.4	
Vert	9608.000	PK	42.2	38.4	7.0	33.3	54.3	73.9	19.6	Floor Noise
Vert	1754.258	AV	52.2	25.8	2.7	33.4	47.3	53.9	6.6	
Vert	1844.170	AV	53.9	25.9	2.9	33.2	49.5	53.9	4.4	
Vert	2390.000	AV	32.6	26.8	3.2	32.7	29.9	53.9	24.0	
Vert	3132.337	AV	49.2	27.5	3.6	32.4	47.9	53.9	6.0	
Vert	4804.000	AV	35.6	30.6	5.2	31.8	39.6	53.9	14.3	
Vert	7206.000	AV	32.2	35.9	6.6	32.7	42.0	53.9	11.9	
Vert	8194.600	AV	42.9	37.1	5.8	32.9	52.9	53.9	1.0	
Vert	9608.000	AV	30.6	38.4	7.0	33.3	42.7	53.9	11.2	Floor Noise

Result = Reading + Ant Factor + Loss (Cable+Attenuator+Filter-Distance factor(above 10GHz)) - Gain(Amplifier)

\*Other frequency noises omitted in this report were not seen or had enough margin (more than 20dB).

\*The 10th harmonic was not seen so the result was its base noise level.

Distance factor: 10GHz-26.5GHz 20log(3.0m/1.0m)= 9.5dB

## Radiated Spurious Emission

Test place : Ise EMC Lab. No.3 Semi Anechoic Chamber  
Report No. : 10607274H  
Date : 03/02/2015  
Temperature/ Humidity : 23deg. C / 39% RH  
Engineer : Takafumi Noguchi  
(1-10GHz)  
Mode : Tx, 3DH5 2402MHz

**20dBc Data Sheet**

Polarity	Frequency [MHz]	Detector	Reading [dBuV]	Ant Factor [dB/m]	Loss [dB]	Gain [dB]	Result [dBuV/m]	Limit [dBuV/m]	Margin [dB]	Remark
Hori	2402.000	PK	96.7	26.8	3.2	32.7	94.0	-	-	Carrier
Hori	2400.000	PK	49.0	26.8	3.2	32.7	46.3	74.0	27.7	
Hori	2399.733	PK	52.6	26.8	3.2	32.7	49.9	74.0	24.1	
Vert	2402.000	PK	98.8	26.8	3.2	32.7	96.1	-	-	Carrier
Vert	2400.000	PK	49.7	26.8	3.2	32.7	47.0	76.1	29.1	
Vert	2399.733	PK	53.4	26.8	3.2	32.7	50.7	76.1	25.4	

Result = Reading + Ant Factor + Loss (Cable+Attenuator+Filter-Distance factor(above 10GHz)) - Gain(Amplifier)

**UL Japan, Inc.**

**Ise EMC Lab.**

4383-326 Asama-cho, Ise-shi, Mie-ken 516-0021 JAPAN

Telephone : +81 596 24 8999

Facsimile : +81 596 24 8124

### Radiated Spurious Emission

Test place Ise EMC Lab. No.3 Semi Anechoic Chamber  
Report No. 10607274H  
Date 03/02/2015 03/04/2015 03/11/2015  
Temperature/ Humidity 23deg. C / 39% RH 25deg. C / 39% RH 20deg. C / 29% RH  
Engineer Takafumi Noguchi Takafumi Noguchi Takafumi Noguchi  
(1-10GHz) (10-26.5GHz) (Below 1GHz)  
Mode Tx, 3DH5 2441MHz

Polarity	Frequency [MHz]	Detector	Reading [dBuV]	Ant.Fac. [dB/m]	Loss [dB]	Gain [dB]	Result [dBuV/m]	Limit [dBuV/m]	Margin [dB]	Remark
Hori	78.131	QP	37.0	6.3	7.8	32.0	19.1	40.0	20.9	
Hori	146.256	QP	37.4	14.7	8.6	32.2	28.5	43.5	15.0	
Hori	243.789	QP	37.4	17.1	9.4	32.1	31.8	46.0	14.2	
Hori	276.029	QP	32.3	18.6	9.8	32.0	28.7	46.0	17.3	
Hori	341.301	QP	32.6	16.0	10.2	32.0	26.8	46.0	19.2	
Hori	390.000	QP	31.3	17.3	10.5	32.0	27.1	46.0	18.9	
Hori	627.162	QP	33.8	19.7	12.0	32.1	33.4	46.0	12.6	
Hori	719.989	QP	27.6	20.8	12.4	32.0	28.8	46.0	17.2	
Hori	866.282	QP	30.8	22.4	13.1	31.2	35.1	46.0	10.9	
Hori	959.950	QP	29.7	23.1	13.5	30.7	35.6	46.0	10.4	
Hori	983.012	QP	37.2	23.3	13.6	30.6	43.5	53.9	10.4	
Hori	1754.000	PK	62.0	25.8	2.7	33.4	57.1	73.9	16.8	
Hori	1844.381	PK	57.7	25.9	2.9	33.2	53.3	73.9	20.6	
Hori	3132.269	PK	49.0	27.5	3.6	32.4	47.7	73.9	26.2	
Hori	4882.000	PK	43.5	30.8	5.3	31.7	47.9	73.9	26.0	
Hori	7323.000	PK	42.9	35.9	6.5	32.7	52.6	73.9	21.3	Floor Noise
Hori	8196.641	PK	46.9	37.1	5.8	32.9	56.9	73.9	17.0	
Hori	9764.000	PK	41.1	38.7	7.1	33.4	53.5	73.9	20.4	Floor Noise
Hori	1754.000	AV	50.1	25.8	2.7	33.4	45.2	53.9	8.7	
Hori	1844.381	AV	51.0	25.9	2.9	33.2	46.6	53.9	7.3	
Hori	3132.269	AV	44.5	27.5	3.6	32.4	43.2	53.9	10.7	
Hori	4882.000	AV	33.7	30.8	5.3	31.7	38.1	53.9	15.8	
Hori	7323.000	AV	31.5	35.9	6.5	32.7	41.2	53.9	12.7	Floor Noise
Hori	8196.641	AV	42.8	37.1	5.8	32.9	52.8	53.9	1.1	
Hori	9764.000	AV	30.2	38.7	7.1	33.4	42.6	53.9	11.3	Floor Noise
Vert	78.381	QP	43.0	6.3	7.8	32.0	25.1	40.0	14.9	
Vert	146.250	QP	35.2	14.7	8.6	32.2	26.3	43.5	17.2	
Vert	243.752	QP	33.0	17.1	9.4	32.1	27.4	46.0	18.6	
Vert	276.011	QP	34.8	18.6	9.8	32.0	31.2	46.0	14.8	
Vert	341.255	QP	30.0	16.0	10.2	32.0	24.2	46.0	21.8	
Vert	390.000	QP	28.4	17.3	10.5	32.0	24.2	46.0	21.8	
Vert	719.965	QP	32.0	20.8	12.4	32.0	33.2	46.0	12.8	
Vert	863.662	QP	30.0	22.4	13.0	31.2	34.2	46.0	11.8	
Vert	959.951	QP	30.1	23.1	13.5	30.7	36.0	46.0	10.0	
Vert	983.020	QP	36.5	23.3	13.6	30.6	42.8	53.9	11.1	
Vert	1754.030	PK	63.8	25.8	2.7	33.4	58.9	73.9	15.0	
Vert	1844.801	PK	64.5	25.9	2.9	33.2	60.1	73.9	13.8	
Vert	3132.330	PK	52.3	27.5	3.6	32.4	51.0	73.9	22.9	
Vert	4882.000	PK	45.0	30.8	5.3	31.7	49.4	73.9	24.5	
Vert	7323.000	PK	43.4	35.9	6.5	32.7	53.1	73.9	20.8	
Vert	8195.630	PK	49.9	37.1	5.8	32.9	59.9	73.9	14.0	
Vert	9764.000	PK	41.0	38.7	7.1	33.4	53.4	73.9	20.5	Floor Noise
Vert	1754.030	AV	53.0	25.8	2.7	33.4	48.1	53.9	5.8	
Vert	1844.801	AV	53.4	25.9	2.9	33.2	49.0	53.9	4.9	
Vert	3132.330	AV	49.1	27.5	3.6	32.4	47.8	53.9	6.1	
Vert	4882.000	AV	35.4	30.8	5.3	31.7	39.8	53.9	14.1	
Vert	7323.000	AV	32.2	35.9	6.5	32.7	41.9	53.9	12.0	
Vert	8195.630	AV	42.8	37.1	5.8	32.9	52.8	53.9	1.1	
Vert	9764.000	AV	30.2	38.7	7.1	33.4	42.6	53.9	11.3	Floor Noise

Result = Reading + Ant Factor + Loss (Cable+Attenuator+Filter-Distance factor(above 10GHz)) - Gain(Amplifier)

\*Other frequency noises omitted in this report were not seen or had enough margin (more than 20dB).

\*The 10th harmonic was not seen so the result was its base noise level.

Distance factor: 10GHz-26.5GHz 20log(3.0m/1.0m)= 9.5dB

## Radiated Spurious Emission (Plot data, Worst margin)

Test place	Ise EMC Lab. No.3 Semi Anechoic Chamber		
Report No.	10607274H		
Date	03/02/2015	03/04/2015	03/11/2015
Temperature/ Humidity	23deg. C / 39% RH	25deg. C / 39% RH	20deg. C / 29% RH
Engineer	Takafumi Noguchi (1-10GHz)	Takafumi Noguchi (10-26.5GHz)	Takafumi Noguchi (Below 1GHz)
Mode	Tx, 3DH5 2441MHz		

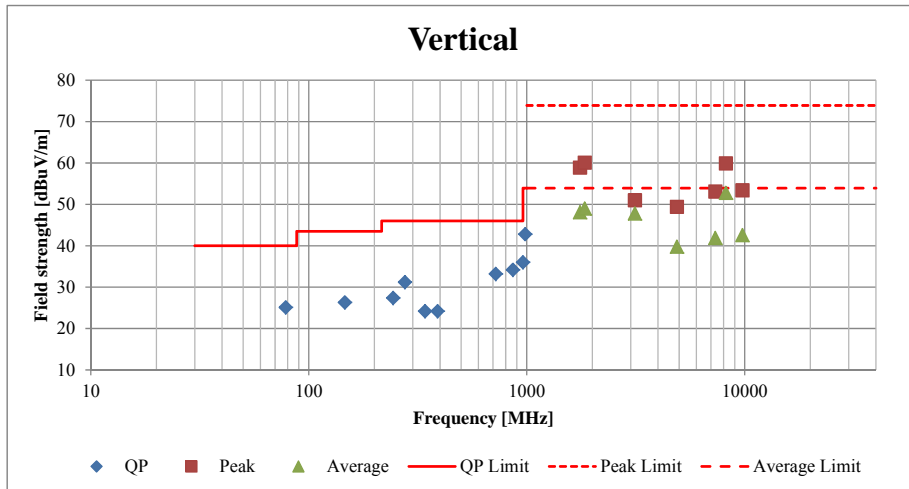
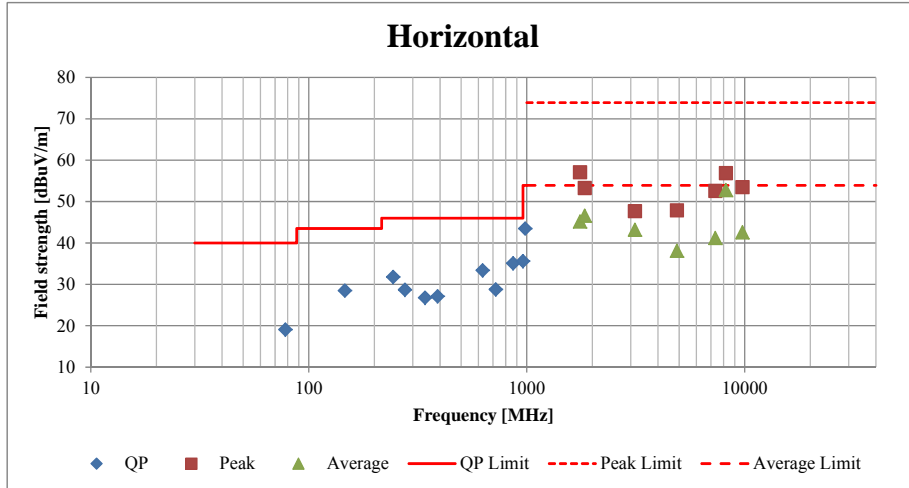

**UL Japan, Inc.**  
**Ise EMC Lab.**

4383-326 Asama-cho, Ise-shi, Mie-ken 516-0021 JAPAN  
 Telephone : +81 596 24 8999  
 Facsimile : +81 596 24 8124

**Radiated Spurious Emission**

Test place Ise EMC Lab. No.3 Semi Anechoic Chamber  
Report No. 10607274H  
Date 03/02/2015 03/04/2015 03/11/2015  
Temperature/ Humidity 23deg. C / 39% RH 25deg. C / 39% RH 20deg. C / 29% RH  
Engineer Takafumi Noguchi Takafumi Noguchi Takafumi Noguchi  
(1-10GHz) (10-26.5GHz) (Below 1GHz)  
Mode Tx, 3DH5 2480MHz

Polarity	Frequency [MHz]	Detector	Reading [dBuV]	Ant.Fac. [dB/m]	Loss [dB]	Gain [dB]	Result [dBuV/m]	Limit [dBuV/m]	Margin [dB]	Remark
Hori	78.156	QP	37.1	6.3	7.8	32.0	19.2	40.0	20.8	
Hori	146.249	QP	37.2	14.7	8.6	32.2	28.3	43.5	15.2	
Hori	243.777	QP	37.3	17.1	9.4	32.1	31.7	46.0	14.3	
Hori	276.027	QP	32.0	18.6	9.8	32.0	28.4	46.0	17.6	
Hori	341.300	QP	32.6	16.0	10.2	32.0	26.8	46.0	19.2	
Hori	390.000	QP	31.3	17.3	10.5	32.0	27.1	46.0	18.9	
Hori	627.154	QP	33.6	19.7	12.0	32.1	33.2	46.0	12.8	
Hori	719.999	QP	27.7	20.8	12.4	32.0	28.9	46.0	17.1	
Hori	866.281	QP	31.0	22.4	13.1	31.2	35.3	46.0	10.7	
Hori	959.944	QP	29.9	23.1	13.5	30.7	35.8	46.0	10.2	
Hori	983.016	QP	37.3	23.3	13.6	30.6	43.6	53.9	10.3	
Hori	1756.699	PK	62.5	25.8	2.7	33.4	57.6	73.9	16.3	
Hori	1844.511	PK	58.0	25.9	2.9	33.2	53.6	73.9	20.3	
Hori	2483.500	PK	50.7	26.9	3.2	32.7	48.1	73.9	25.8	
Hori	3132.258	PK	49.2	27.5	3.6	32.4	47.9	73.9	26.0	
Hori	4960.000	PK	41.7	30.9	5.2	31.7	46.1	73.9	27.8	
Hori	7440.000	PK	42.5	35.9	6.6	32.7	52.3	73.9	21.6	Floor Noise
Hori	8196.771	PK	47.1	37.1	5.8	32.9	57.1	73.9	16.8	
Hori	9920.000	PK	41.1	38.9	7.1	33.5	53.6	73.9	20.3	Floor Noise
Hori	1756.699	AV	50.6	25.8	2.7	33.4	45.7	53.9	8.2	
Hori	1844.511	AV	51.0	25.9	2.9	33.2	46.6	53.9	7.3	
Hori	2483.500	AV	32.6	26.9	3.2	32.7	30.0	53.9	23.9	
Hori	3132.258	AV	45.0	27.5	3.6	32.4	43.7	53.9	10.2	
Hori	4960.000	AV	31.8	30.9	5.2	31.7	36.2	53.9	17.7	
Hori	7440.000	AV	30.8	35.9	6.6	32.7	40.6	53.9	13.3	Floor Noise
Hori	8196.771	AV	43.1	37.1	5.8	32.9	53.1	53.9	0.8	
Hori	9920.000	AV	30.2	38.9	7.1	33.5	42.7	53.9	11.2	Floor Noise
Vert	78.401	QP	42.9	6.3	7.8	32.0	25.0	40.0	15.0	
Vert	146.244	QP	35.0	14.7	8.6	32.2	26.1	43.5	17.4	
Vert	243.755	QP	33.1	17.1	9.4	32.1	27.5	46.0	18.5	
Vert	276.020	QP	34.6	18.6	9.8	32.0	31.0	46.0	15.0	
Vert	341.261	QP	29.9	16.0	10.2	32.0	24.1	46.0	21.9	
Vert	390.000	QP	28.5	17.3	10.5	32.0	24.3	46.0	21.7	
Vert	719.971	QP	31.8	20.8	12.4	32.0	33.0	46.0	13.0	
Vert	863.660	QP	30.0	22.4	13.0	31.2	34.2	46.0	11.8	
Vert	959.952	QP	30.2	23.1	13.5	30.7	36.1	46.0	9.9	
Vert	983.019	QP	36.3	23.3	13.6	30.6	42.6	53.9	11.3	
Vert	1754.252	PK	64.0	25.8	2.7	33.4	59.1	73.9	14.8	
Vert	1844.232	PK	65.0	25.9	2.9	33.2	60.6	73.9	13.3	
Vert	2483.500	PK	51.9	26.9	3.2	32.7	49.3	73.9	24.6	
Vert	3132.330	PK	52.5	27.5	3.6	32.4	51.2	73.9	22.7	
Vert	4960.000	PK	44.0	30.9	5.2	31.7	48.4	73.9	25.5	
Vert	7440.000	PK	45.8	35.9	6.6	32.7	55.6	73.9	18.3	Floor Noise
Vert	8194.623	PK	49.4	37.1	5.8	32.9	59.4	73.9	14.5	
Vert	9920.000	PK	41.6	38.9	7.1	33.5	54.1	73.9	19.8	Floor Noise
Vert	1754.252	AV	53.0	25.8	2.7	33.4	48.1	53.9	5.8	
Vert	1844.232	AV	54.0	25.9	2.9	33.2	49.6	53.9	4.3	
Vert	2483.500	AV	34.4	26.9	3.2	32.7	31.8	53.9	22.1	
Vert	3132.330	AV	49.5	27.5	3.6	32.4	48.2	53.9	5.7	
Vert	4960.000	AV	34.2	30.9	5.2	31.7	38.6	53.9	15.3	
Vert	7440.000	AV	34.8	35.9	6.6	32.7	44.6	53.9	9.3	Floor Noise
Vert	8194.623	AV	43.0	37.1	5.8	32.9	53.0	53.9	0.9	
Vert	9920.000	AV	28.7	38.9	7.1	33.5	41.2	53.9	12.7	Floor Noise

Result = Reading + Ant Factor + Loss (Cable+Attenuator+Filter-Distance factor(above 10GHz)) - Gain(Amplifier)

\*Other frequency noises omitted in this report were not seen or had enough margin (more than 20dB).

\*The 10th harmonic was not seen so the result was its base noise level.

Distance factor: 10GHz-26.5GHz 20log(3.0m/1.0m)= 9.5dB

### Burst Rate Confirmation

Test place	Ise EMC Lab. No.11 Measurement Room
Report No.	10607274H
Date	03/06/2015
Temperature/ Humidity	23deg. C / 32% RH
Engineer	Tsubasa Takayama
Mode	Tx (Hopping on) DH5 / 3DH5

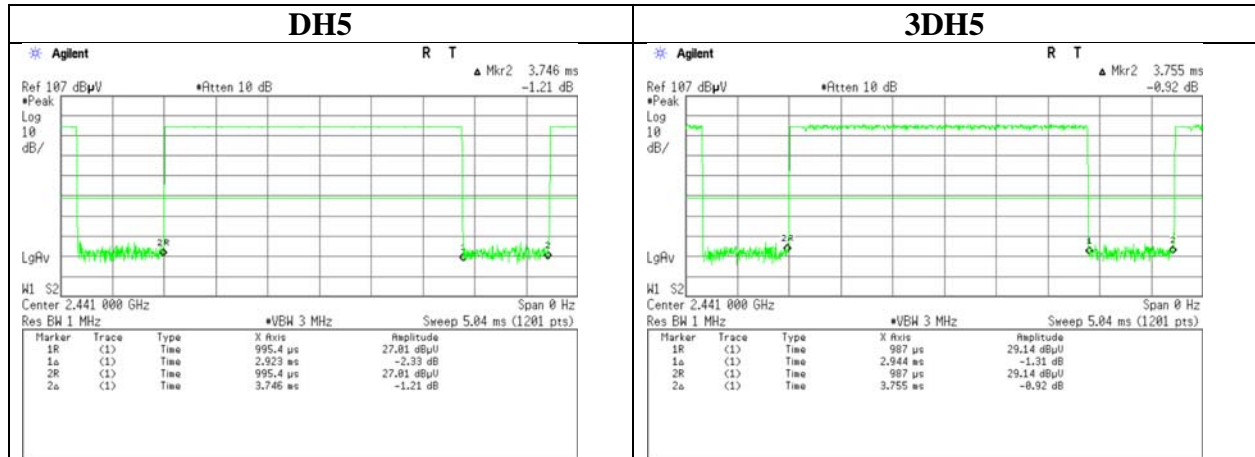

**UL Japan, Inc.**

**Ise EMC Lab.**

4383-326 Asama-cho, Ise-shi, Mie-ken 516-0021 JAPAN

Telephone : +81 596 24 8999

Facsimile : +81 596 24 8124



**Conducted Spurious Emission**

Test place : Ise EMC Lab. No.11 Measurement Room  
Report No. : 10607274H  
Date : 03/05/2015  
Temperature/ Humidity : 21deg. C / 30% RH  
Engineer : Tsubasa Takayama  
Mode : Tx (Hopping off) DH5

**Tx DH5 2402MHz**

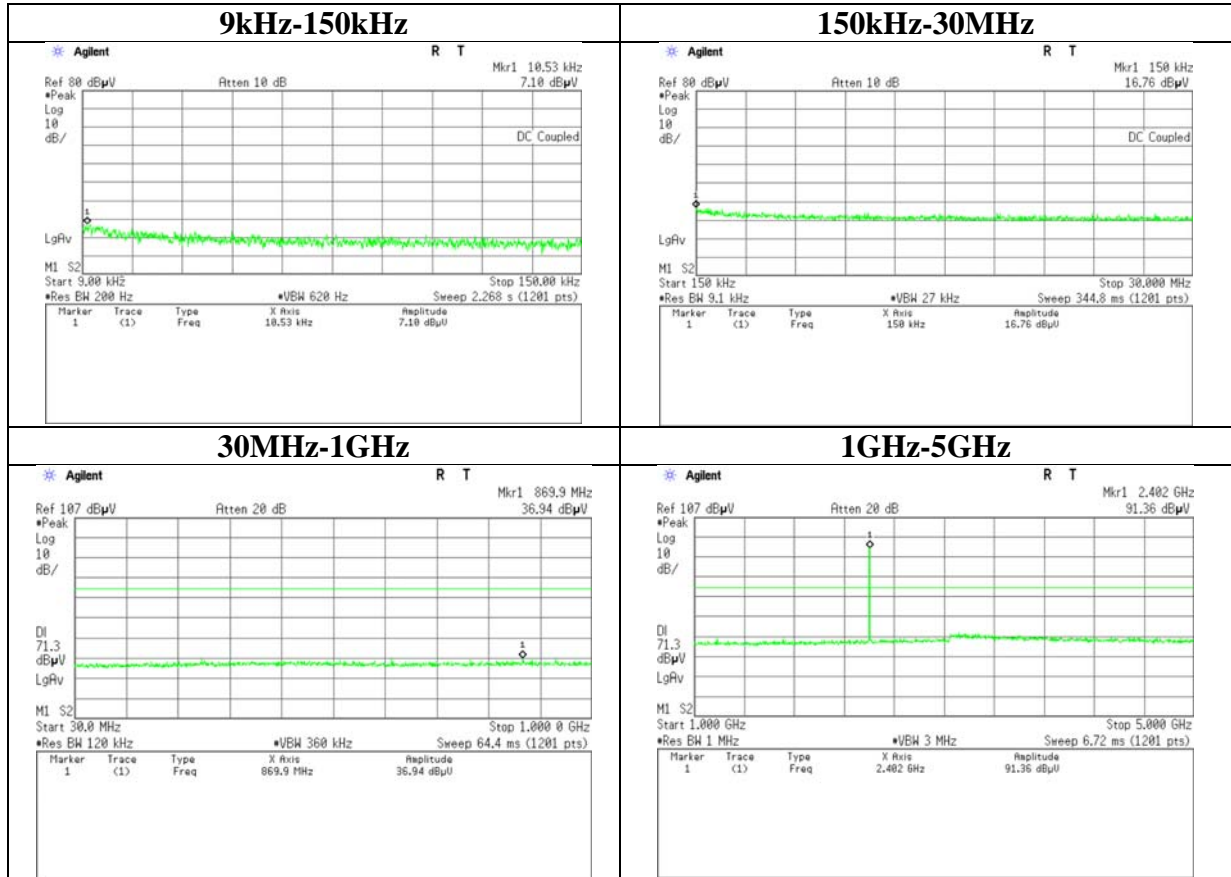

**UL Japan, Inc.**  
**Ise EMC Lab.**

4383-326 Asama-cho, Ise-shi, Mie-ken 516-0021 JAPAN  
Telephone : +81 596 24 8999  
Facsimile : +81 596 24 8124

### Conducted Spurious Emission

Test place	Ise EMC Lab. No.11 Measurement Room
Report No.	10607274H
Date	03/05/2015
Temperature/ Humidity	21deg. C / 30% RH
Engineer	Tsubasa Takayama
Mode	Tx (Hopping off) DH5

#### Tx DH5 2402MHz

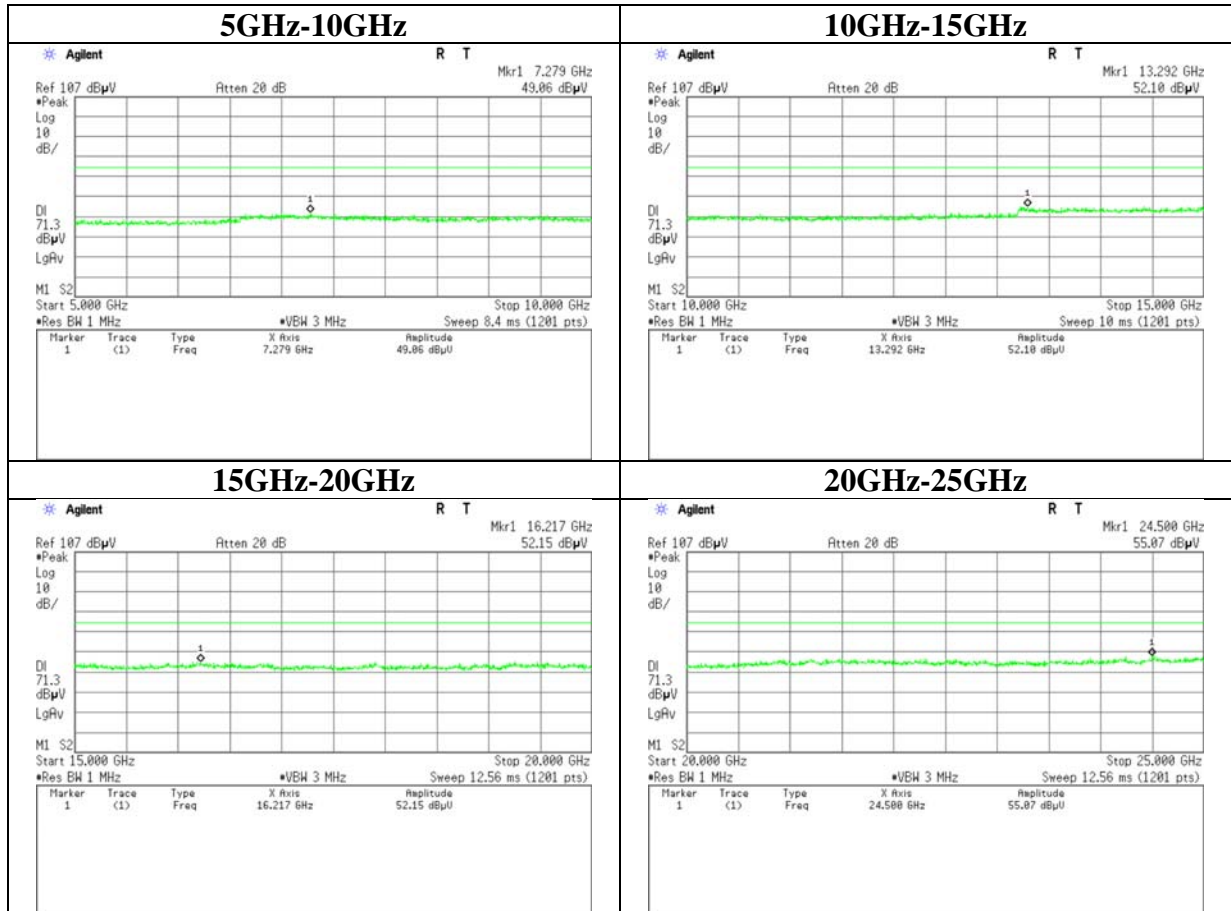

**UL Japan, Inc.**

**Ise EMC Lab.**

4383-326 Asama-cho, Ise-shi, Mie-ken 516-0021 JAPAN

Telephone : +81 596 24 8999

Facsimile : +81 596 24 8124

### Conducted Spurious Emission

Test place	Ise EMC Lab. No.11 Measurement Room
Report No.	10607274H
Date	03/05/2015
Temperature/ Humidity	21deg. C / 30% RH
Engineer	Tsubasa Takayama
Mode	Tx (Hopping off) DH5

#### Tx DH5 2441MHz

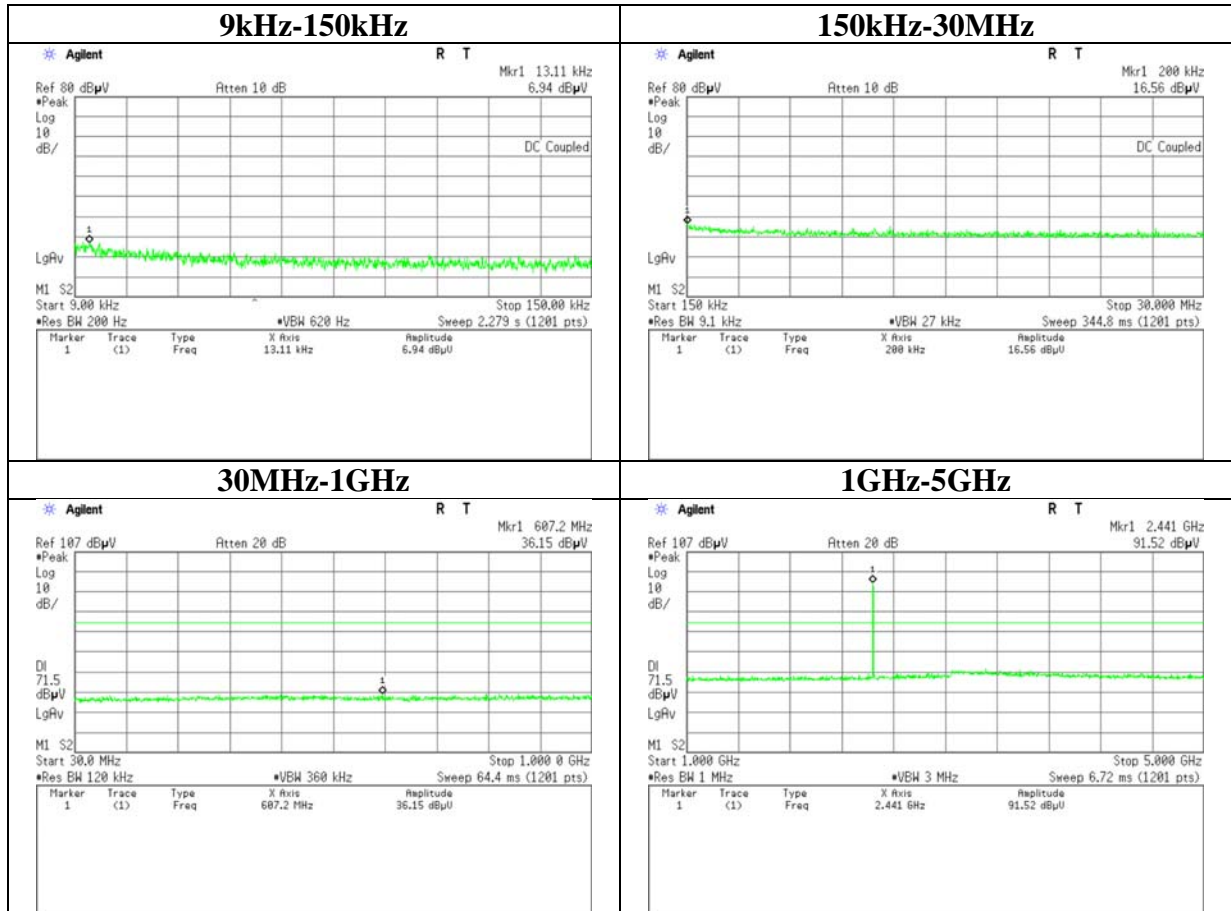

**UL Japan, Inc.**  
**Ise EMC Lab.**

4383-326 Asama-cho, Ise-shi, Mie-ken 516-0021 JAPAN  
Telephone : +81 596 24 8999  
Facsimile : +81 596 24 8124

### Conducted Spurious Emission

Test place	Ise EMC Lab. No.11 Measurement Room
Report No.	10607274H
Date	03/05/2015
Temperature/ Humidity	21deg. C / 30% RH
Engineer	Tsubasa Takayama
Mode	Tx (Hopping on/off) DH5

#### Tx DH5 2441MHz

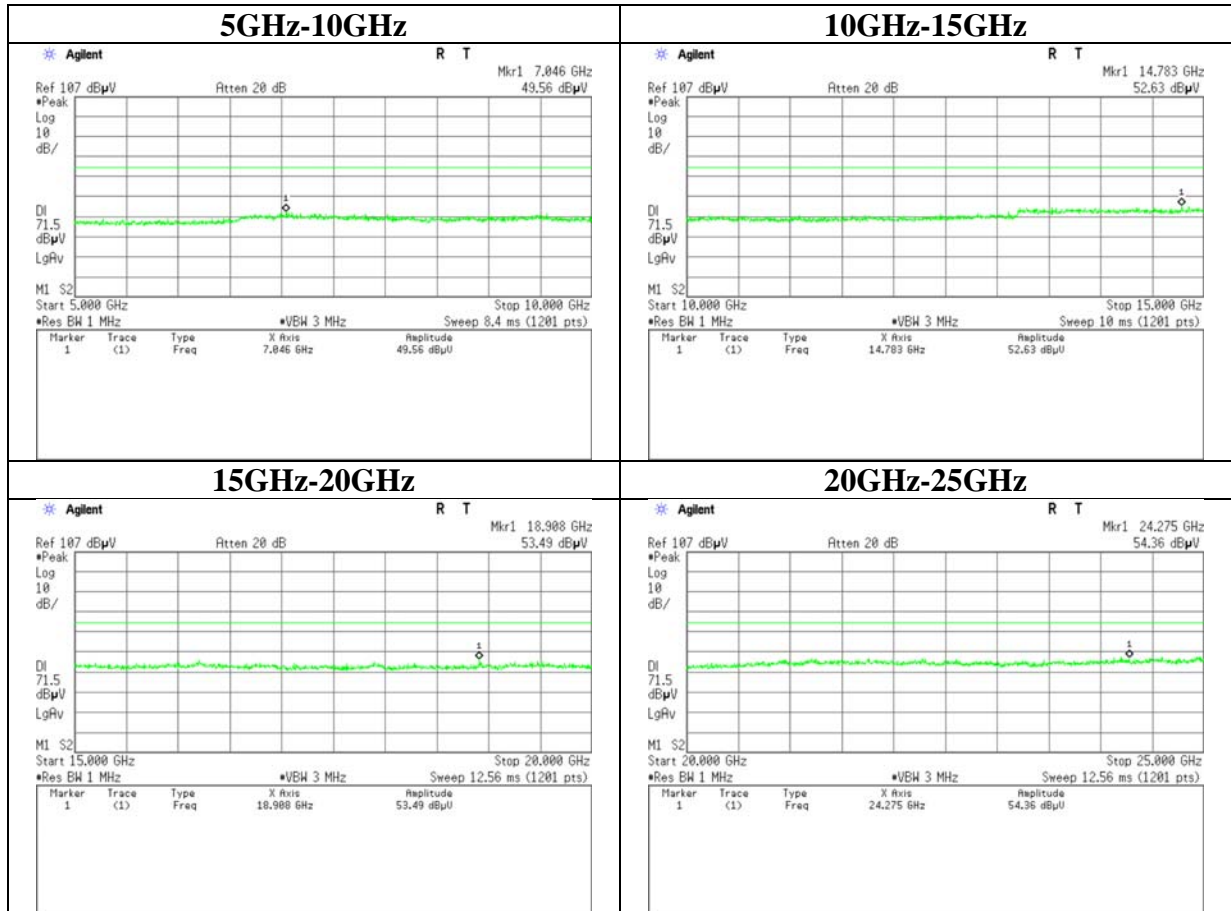

**UL Japan, Inc.**

**Ise EMC Lab.**

4383-326 Asama-cho, Ise-shi, Mie-ken 516-0021 JAPAN

Telephone : +81 596 24 8999

Facsimile : +81 596 24 8124

### Conducted Spurious Emission

Test place	Ise EMC Lab. No.11 Measurement Room
Report No.	10607274H
Date	03/05/2015
Temperature/ Humidity	21deg. C / 30% RH
Engineer	Tsubasa Takayama
Mode	Tx (Hopping off) DH5

#### Tx DH5 2480MHz

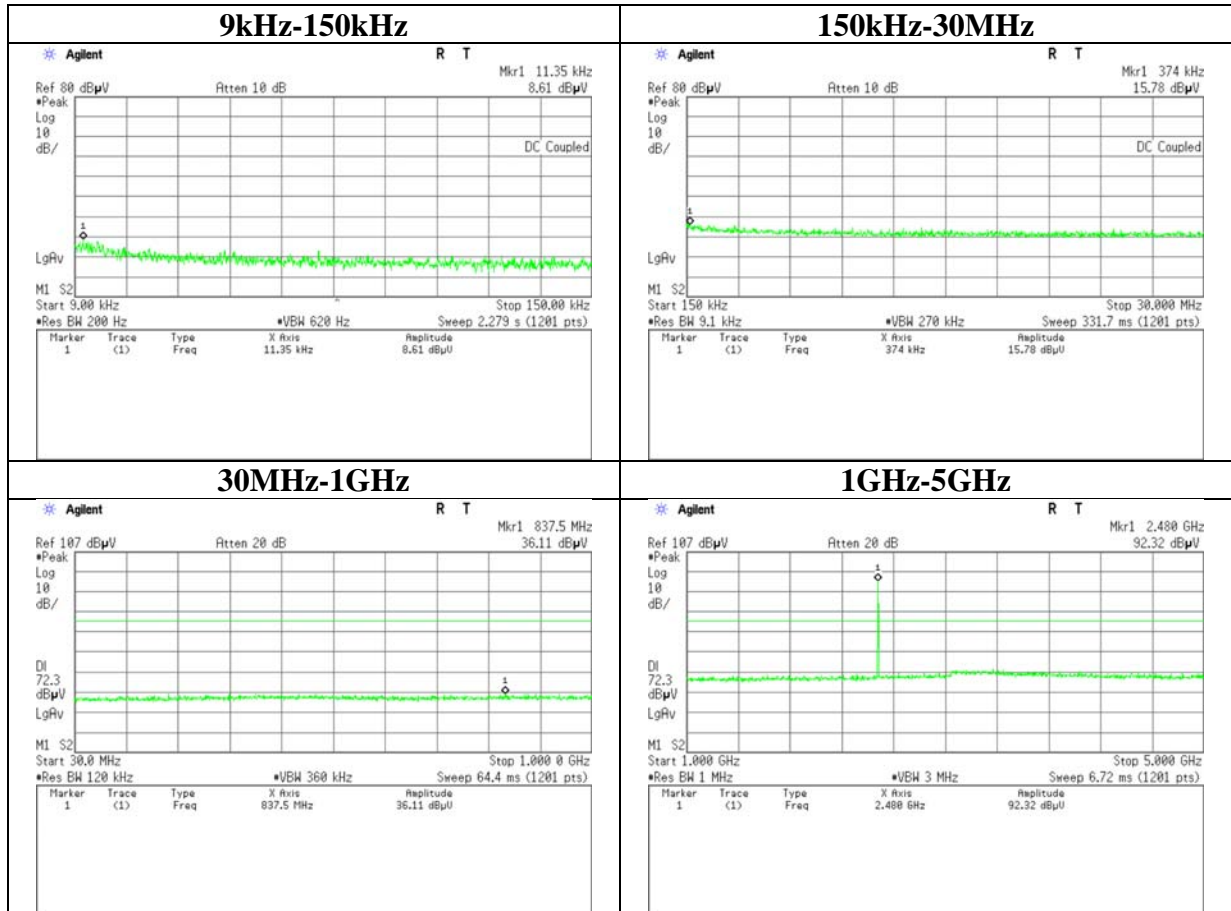

**UL Japan, Inc.**

**Ise EMC Lab.**

4383-326 Asama-cho, Ise-shi, Mie-ken 516-0021 JAPAN

Telephone : +81 596 24 8999

Facsimile : +81 596 24 8124

### Conducted Spurious Emission

Test place	Ise EMC Lab. No.11 Measurement Room
Report No.	10607274H
Date	03/05/2015
Temperature/ Humidity	21deg. C / 30% RH
Engineer	Tsubasa Takayama
Mode	Tx (Hopping off) DH5

#### Tx DH5 2480MHz

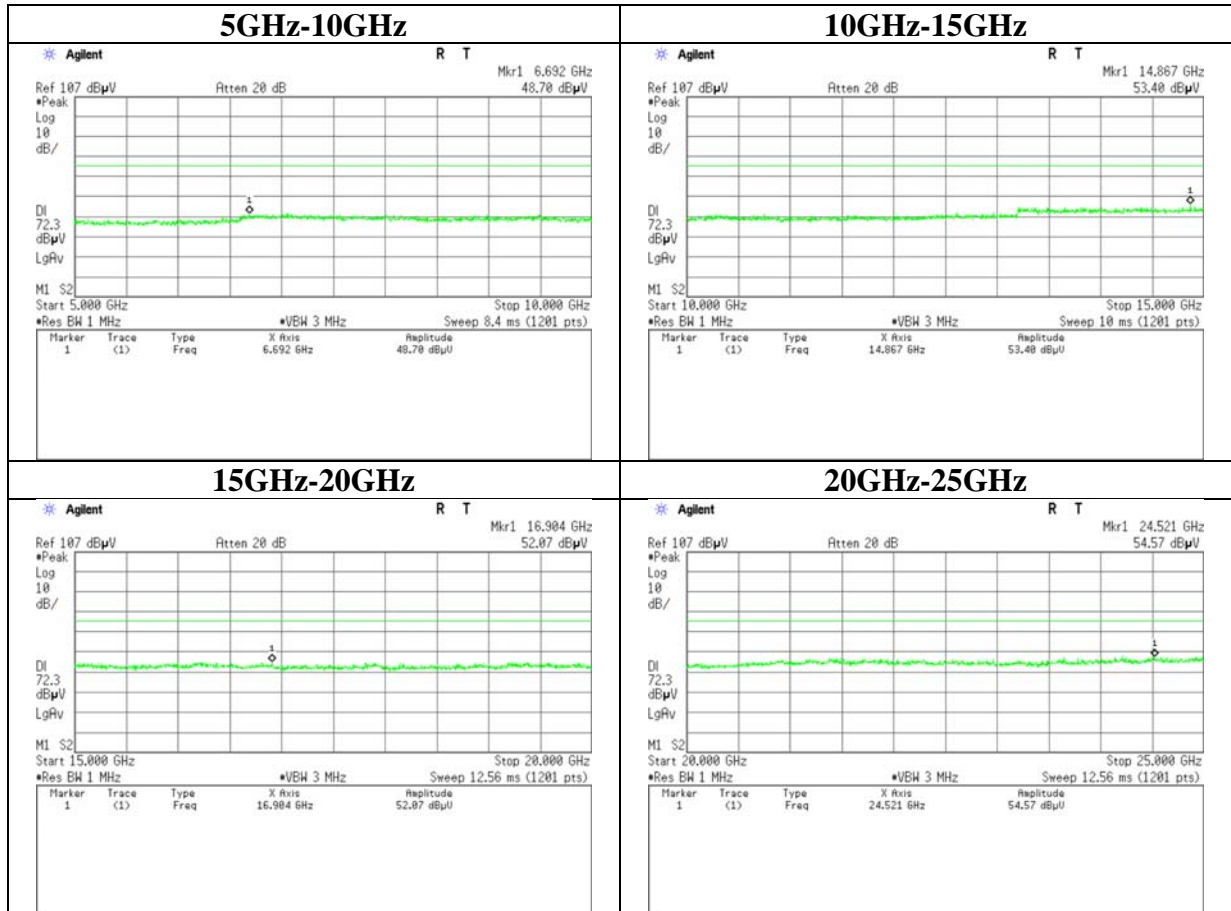

**UL Japan, Inc.**

**Ise EMC Lab.**

4383-326 Asama-cho, Ise-shi, Mie-ken 516-0021 JAPAN

Telephone : +81 596 24 8999

Facsimile : +81 596 24 8124

### Conducted Spurious Emission

Test place	Ise EMC Lab. No.11 Measurement Room
Report No.	10607274H
Date	03/05/2015
Temperature/ Humidity	21deg. C / 30% RH
Engineer	Tsubasa Takayama
Mode	Tx (Hopping off) 3DH5

#### Tx 3DH5 2402MHz

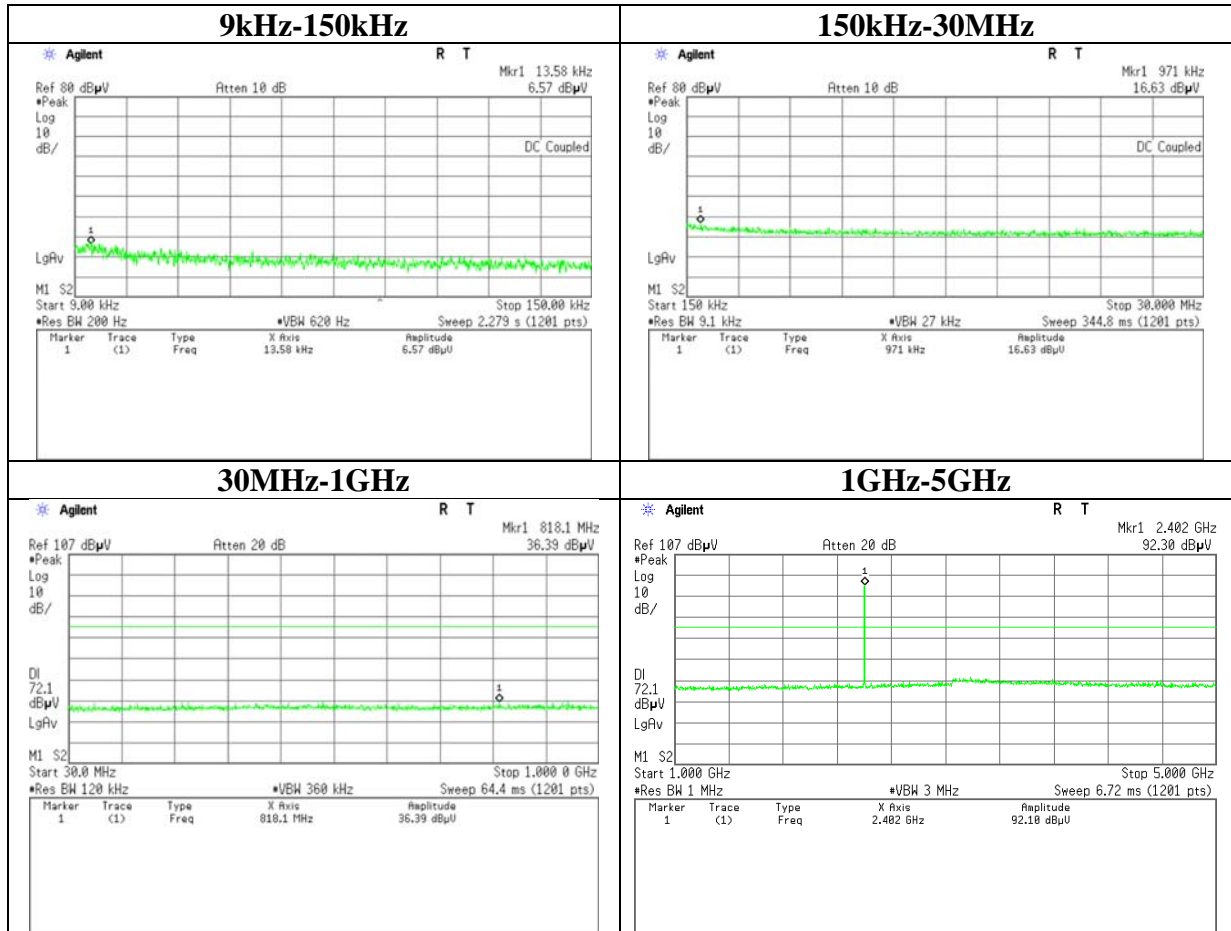

**UL Japan, Inc.**  
**Ise EMC Lab.**

4383-326 Asama-cho, Ise-shi, Mie-ken 516-0021 JAPAN  
Telephone : +81 596 24 8999  
Facsimile : +81 596 24 8124

## Conducted Spurious Emission

Test place	Ise EMC Lab. No.11 Measurement Room
Report No.	10607274H
Date	03/05/2015
Temperature/ Humidity	21deg. C / 30% RH
Engineer	Tsubasa Takayama
Mode	Tx (Hopping off) 3DH5

### Tx 3DH5 2402MHz

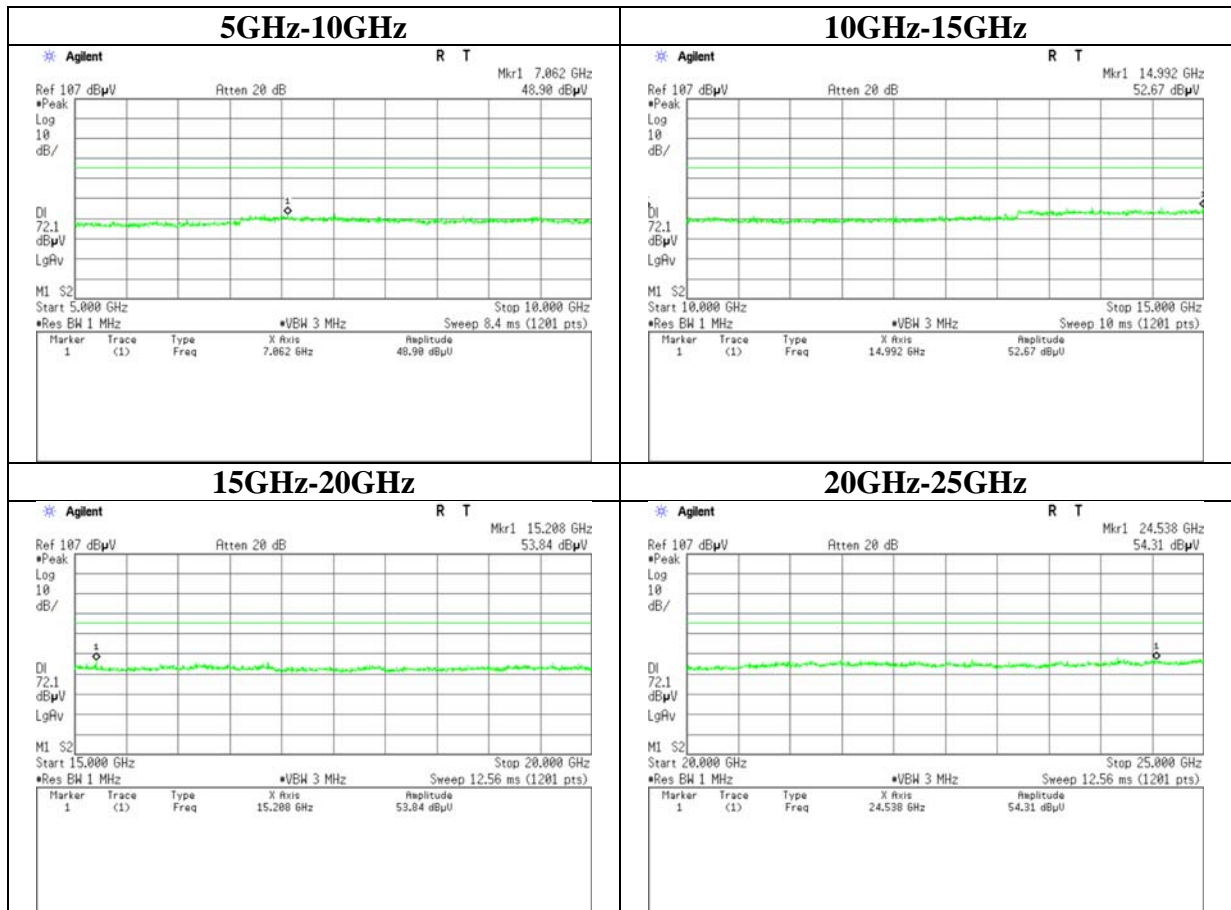

**UL Japan, Inc.**

**Ise EMC Lab.**

4383-326 Asama-cho, Ise-shi, Mie-ken 516-0021 JAPAN

Telephone : +81 596 24 8999

Facsimile : +81 596 24 8124



### Conducted Spurious Emission

Test place	Ise EMC Lab. No.11 Measurement Room
Report No.	10607274H
Date	03/05/2015
Temperature/ Humidity	21deg. C / 30% RH
Engineer	Tsubasa Takayama
Mode	Tx (Hopping off) 3DH5

#### Tx 3DH5 2441MHz

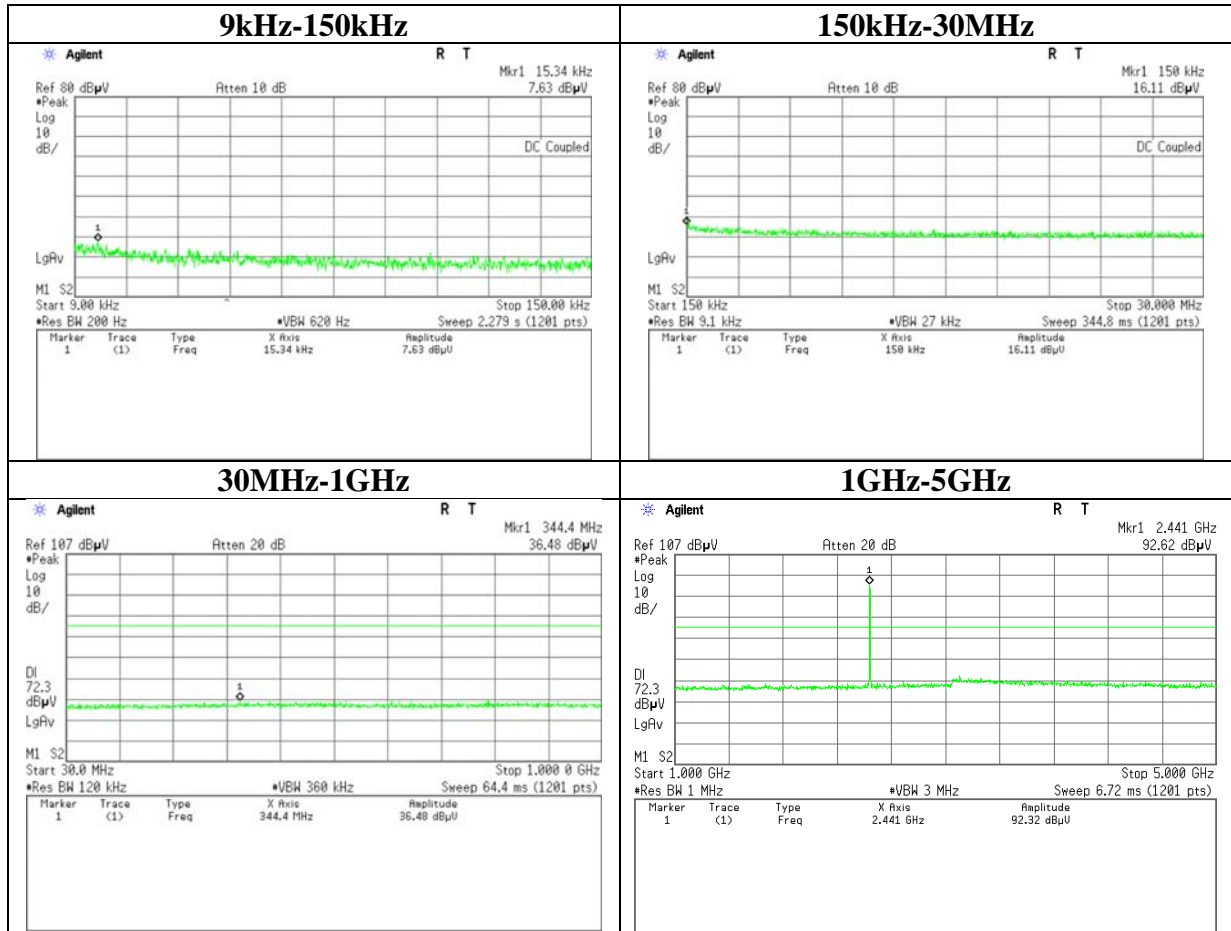

**UL Japan, Inc.**

**Ise EMC Lab.**

4383-326 Asama-cho, Ise-shi, Mie-ken 516-0021 JAPAN

Telephone : +81 596 24 8999

Facsimile : +81 596 24 8124

## Conducted Spurious Emission

Test place	Ise EMC Lab. No.11 Measurement Room
Report No.	10607274H
Date	03/05/2015
Temperature/ Humidity	21deg. C / 30% RH
Engineer	Tsubasa Takayama
Mode	Tx (Hopping off) 3DH5

### Tx 3DH5 2441MHz

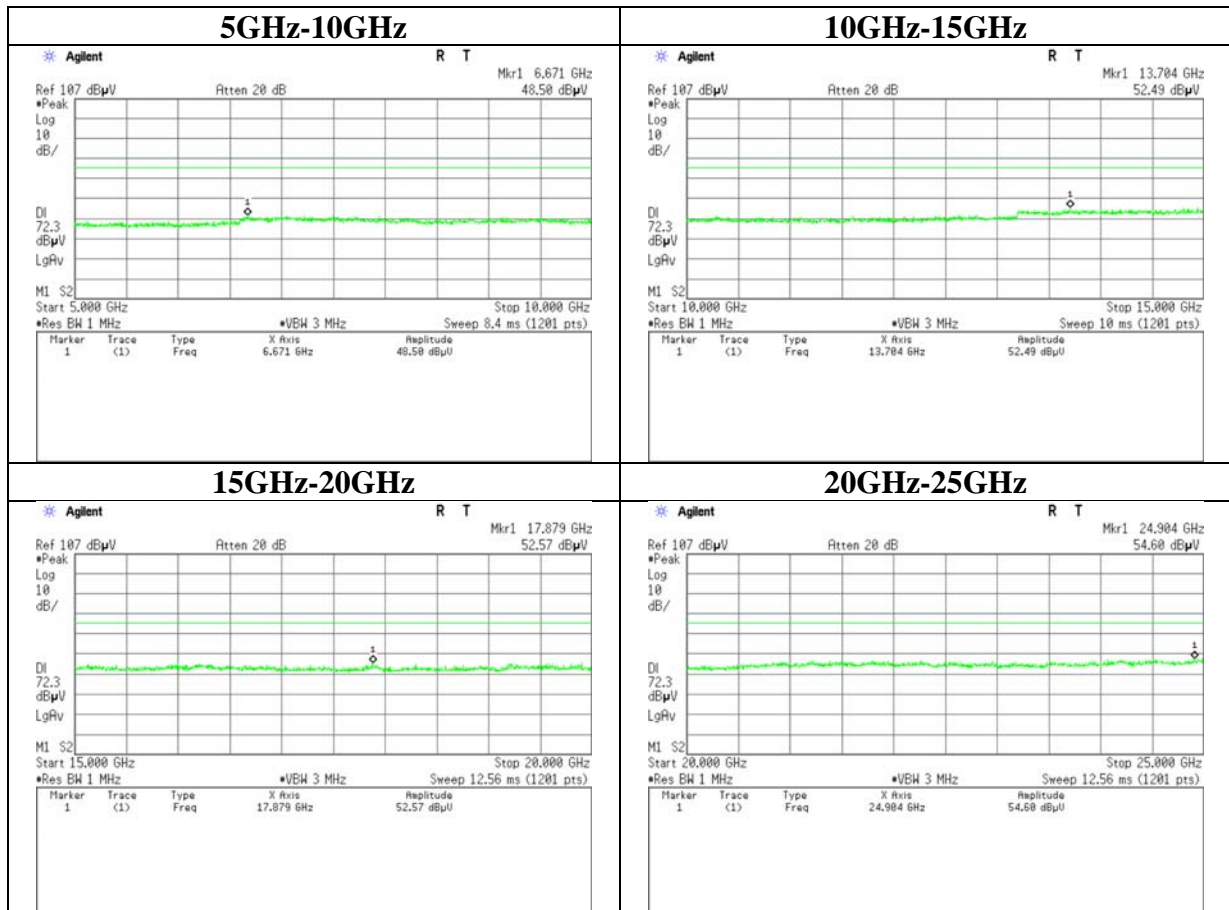

**UL Japan, Inc.**

**Ise EMC Lab.**

4383-326 Asama-cho, Ise-shi, Mie-ken 516-0021 JAPAN

Telephone : +81 596 24 8999

Facsimile : +81 596 24 8124

### Conducted Spurious Emission

Test place	Ise EMC Lab. No.11 Measurement Room
Report No.	10607274H
Date	03/05/2015
Temperature/ Humidity	21deg. C / 30% RH
Engineer	Tsubasa Takayama
Mode	Tx (Hopping off) 3DH5

#### Tx 3DH5 2480MHz

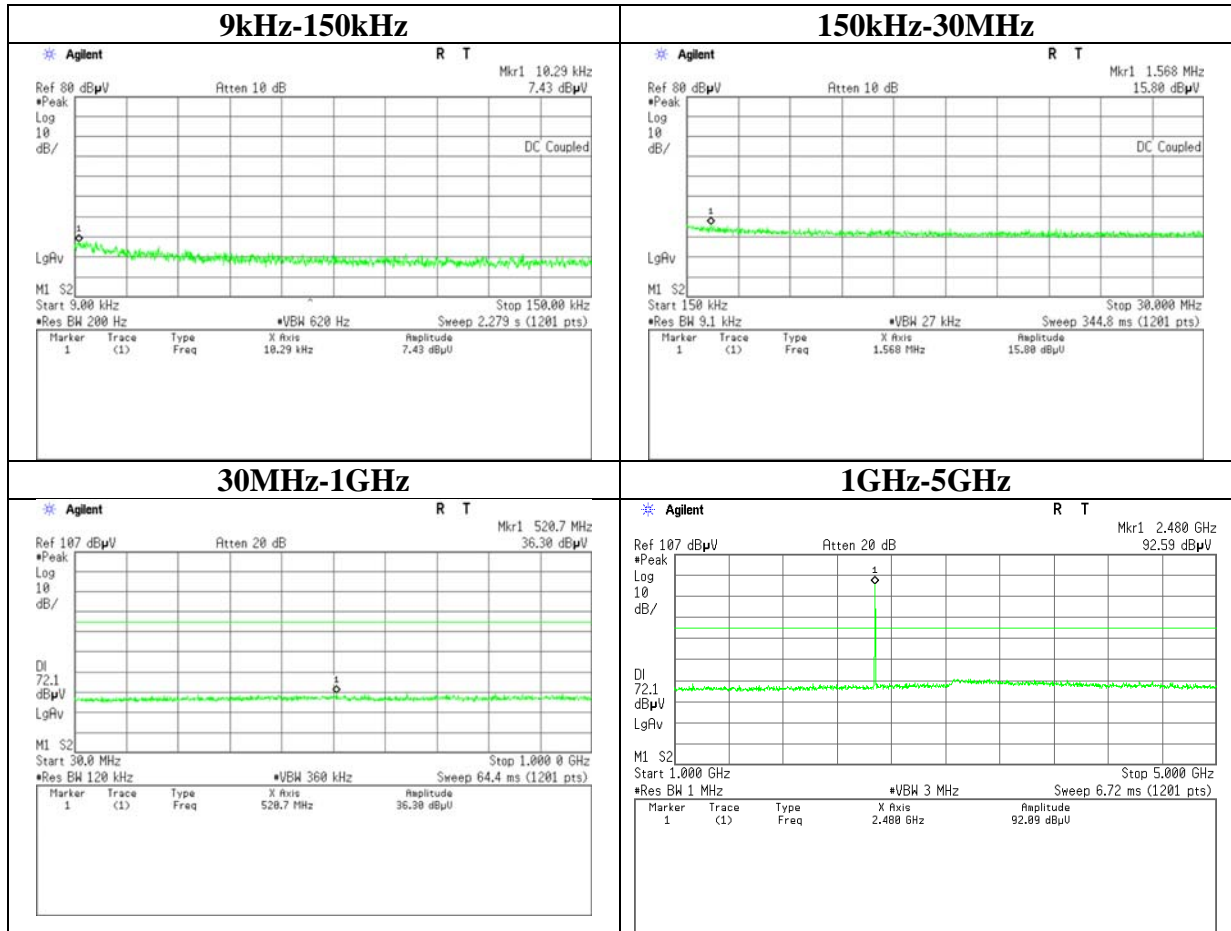

**UL Japan, Inc.**

**Ise EMC Lab.**

4383-326 Asama-cho, Ise-shi, Mie-ken 516-0021 JAPAN

Telephone : +81 596 24 8999

Facsimile : +81 596 24 8124

### Conducted Spurious Emission

Test place	Ise EMC Lab. No.11 Measurement Room
Report No.	10607274H
Date	03/05/2015
Temperature/ Humidity	21deg. C / 30% RH
Engineer	Tsubasa Takayama
Mode	Tx (Hopping off) 3DH5

#### Tx 3DH5 2480MHz

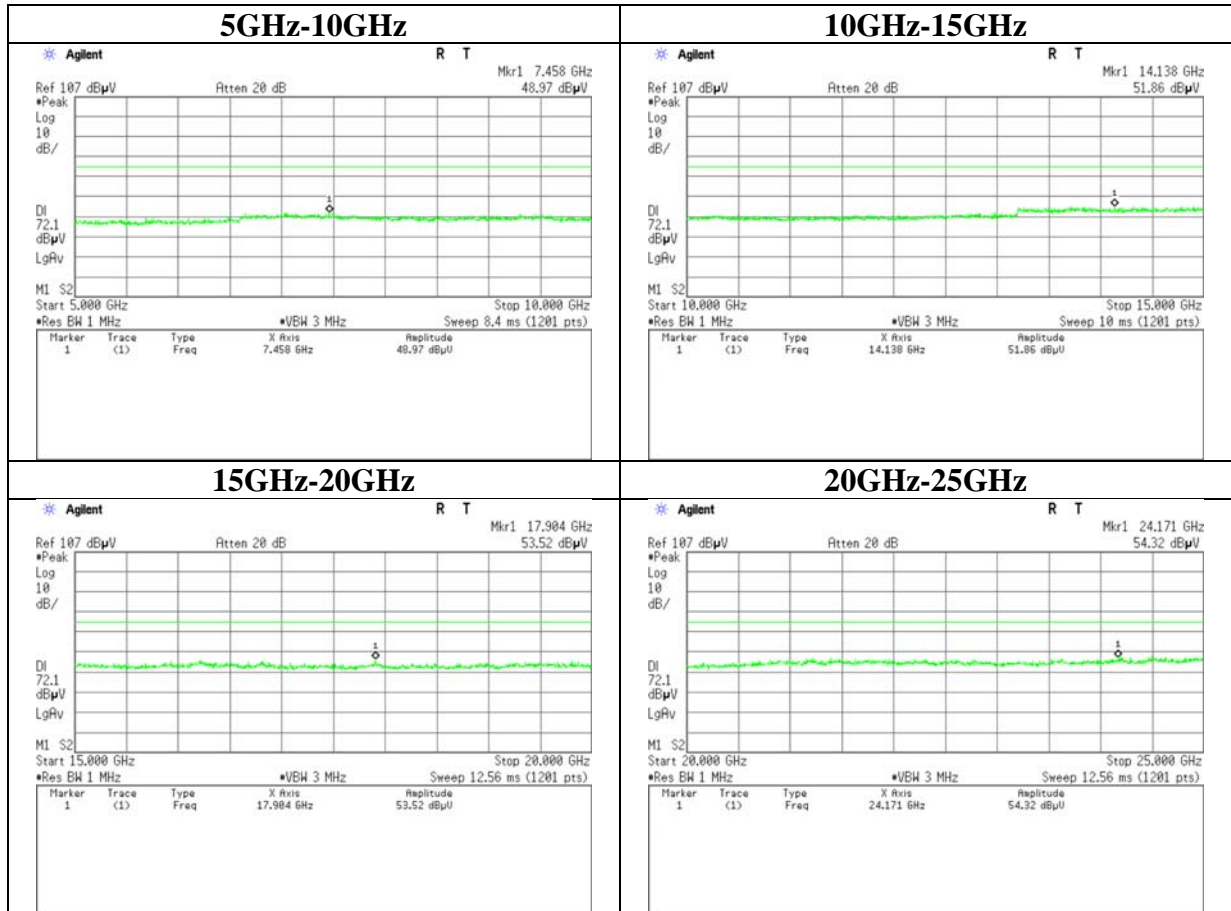

**UL Japan, Inc.**

**Ise EMC Lab.**

4383-326 Asama-cho, Ise-shi, Mie-ken 516-0021 JAPAN

Telephone : +81 596 24 8999

Facsimile : +81 596 24 8124

**Conducted Emission Band Edge compliance**

Test place : Ise EMC Lab. No.11 Measurement Room  
Report No. : 10607274H  
Date : 03/06/2015  
Temperature/ Humidity : 23deg. C / 32% RH  
Engineer : Tsubasa Takayama  
Mode : Tx (Hopping on/off) DH5

**Tx DH5, Hopping on**

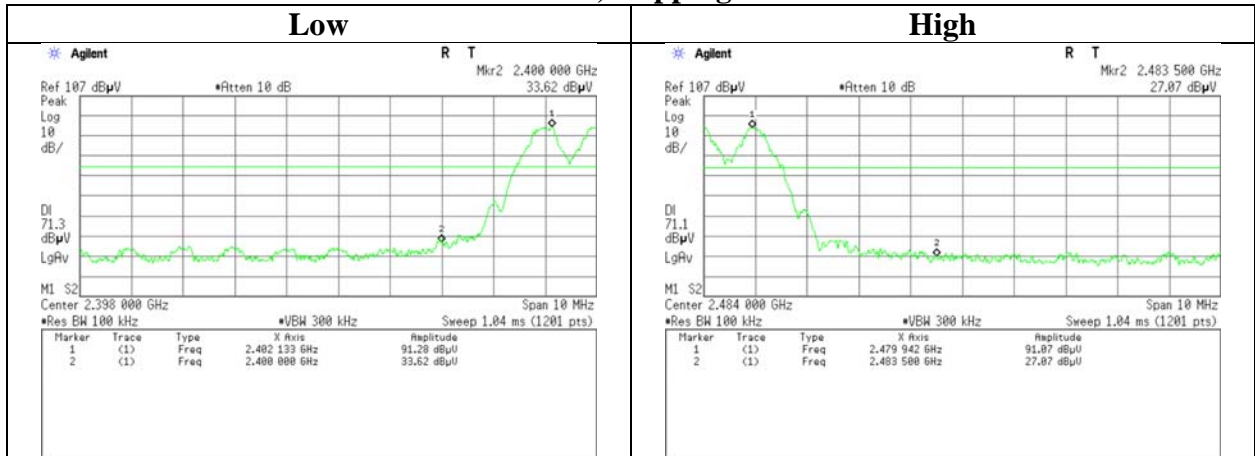

**Tx DH5, Hopping off**

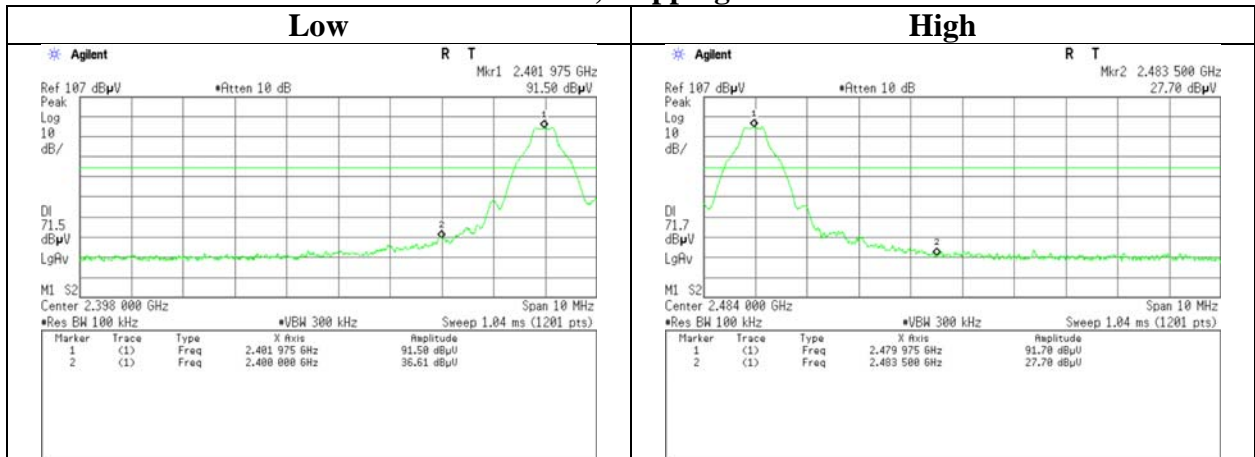

### Conducted Emission Band Edge compliance

Test place	Ise EMC Lab. No.11 Measurement Room
Report No.	10607274H
Date	03/06/2015
Temperature/ Humidity	23deg. C / 32% RH
Engineer	Tsubasa Takayama
Mode	Tx (Hopping on/off) 3DH5

#### Tx 3DH5, Hopping on

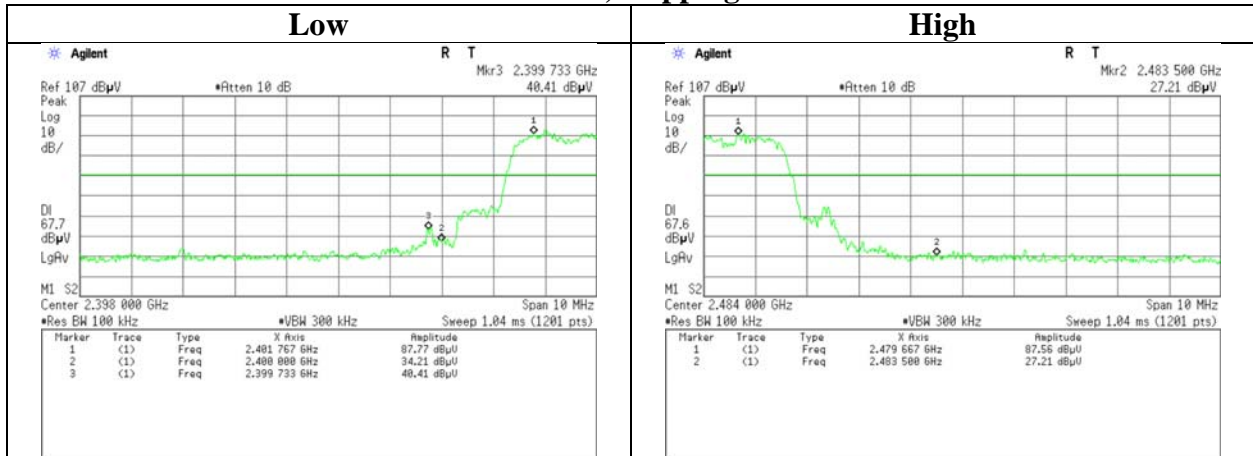

#### Tx 3DH5, Hopping off

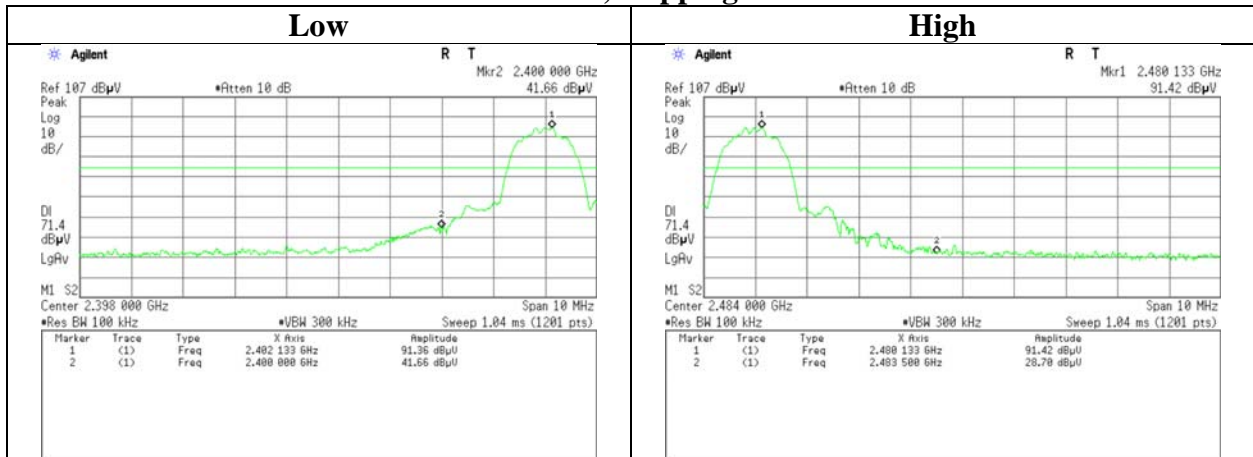

**UL Japan, Inc.**

**Ise EMC Lab.**

4383-326 Asama-cho, Ise-shi, Mie-ken 516-0021 JAPAN

Telephone : +81 596 24 8999

Facsimile : +81 596 24 8124

### 99%Occupied Bandwidth

Test place	Ise EMC Lab. No.11 Measurement Room
Report No.	10607274H
Date	03/05/2015
Temperature/ Humidity	21deg. C / 30% RH
Engineer	Tsubasa Takayama
Mode	Tx (Hopping off) DH5/3DH5

#### Tx DH5, Hopping off

#### Tx 3DH5, Hopping off

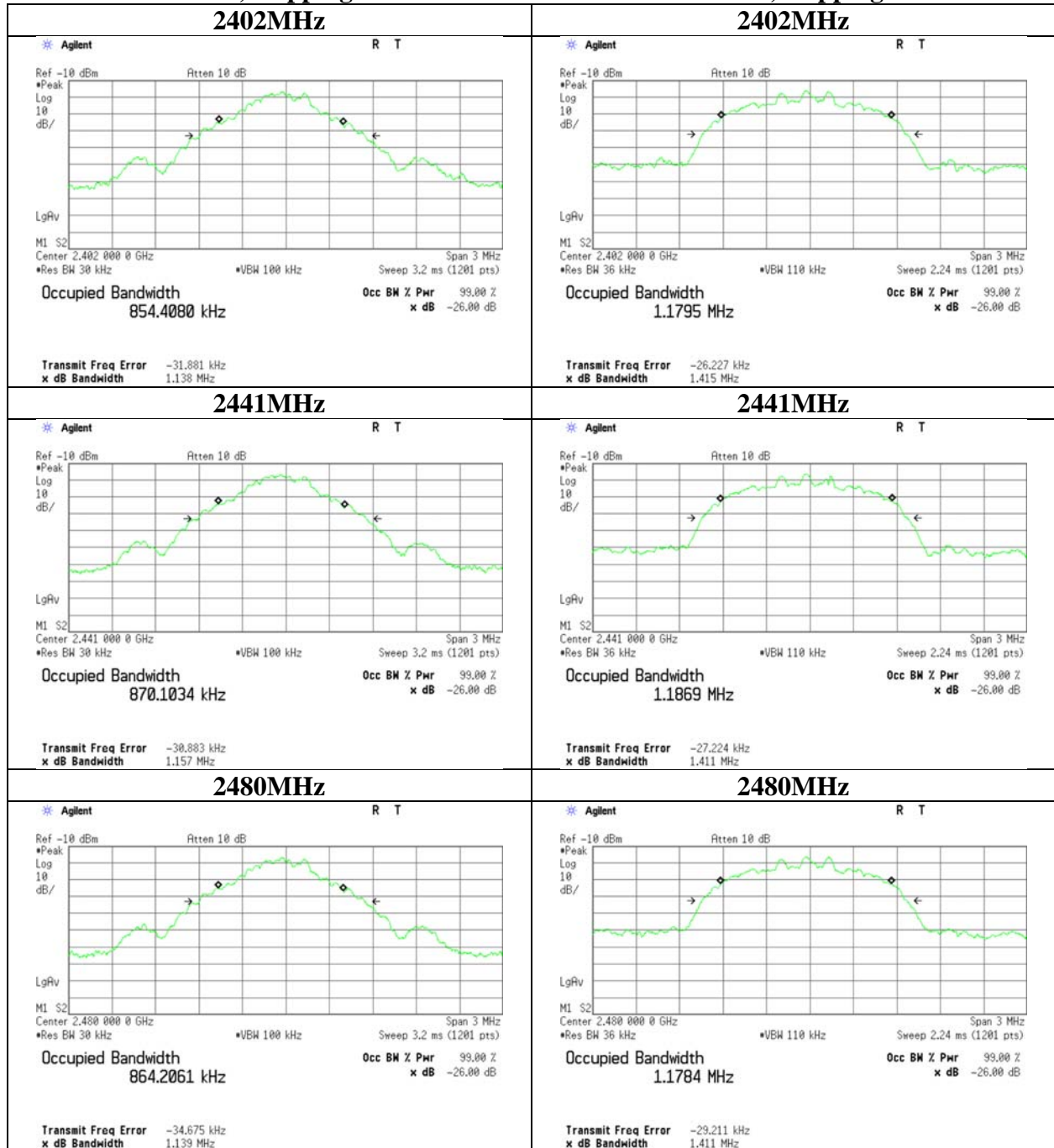

**UL Japan, Inc.**

**Ise EMC Lab.**

4383-326 Asama-cho, Ise-shi, Mie-ken 516-0021 JAPAN

Telephone : +81 596 24 8999

Facsimile : +81 596 24 8124

### 99% Occupied Bandwidth

Test place	Ise EMC Lab. No.11 Measurement Room
Report No.	10607274H
Date	03/10/2015
Temperature/ Humidity	21deg. C / 30% RH
Engineer	Keisuke Kawamura
Mode	Tx (Hopping on) DH5/3DH5/Inquiry

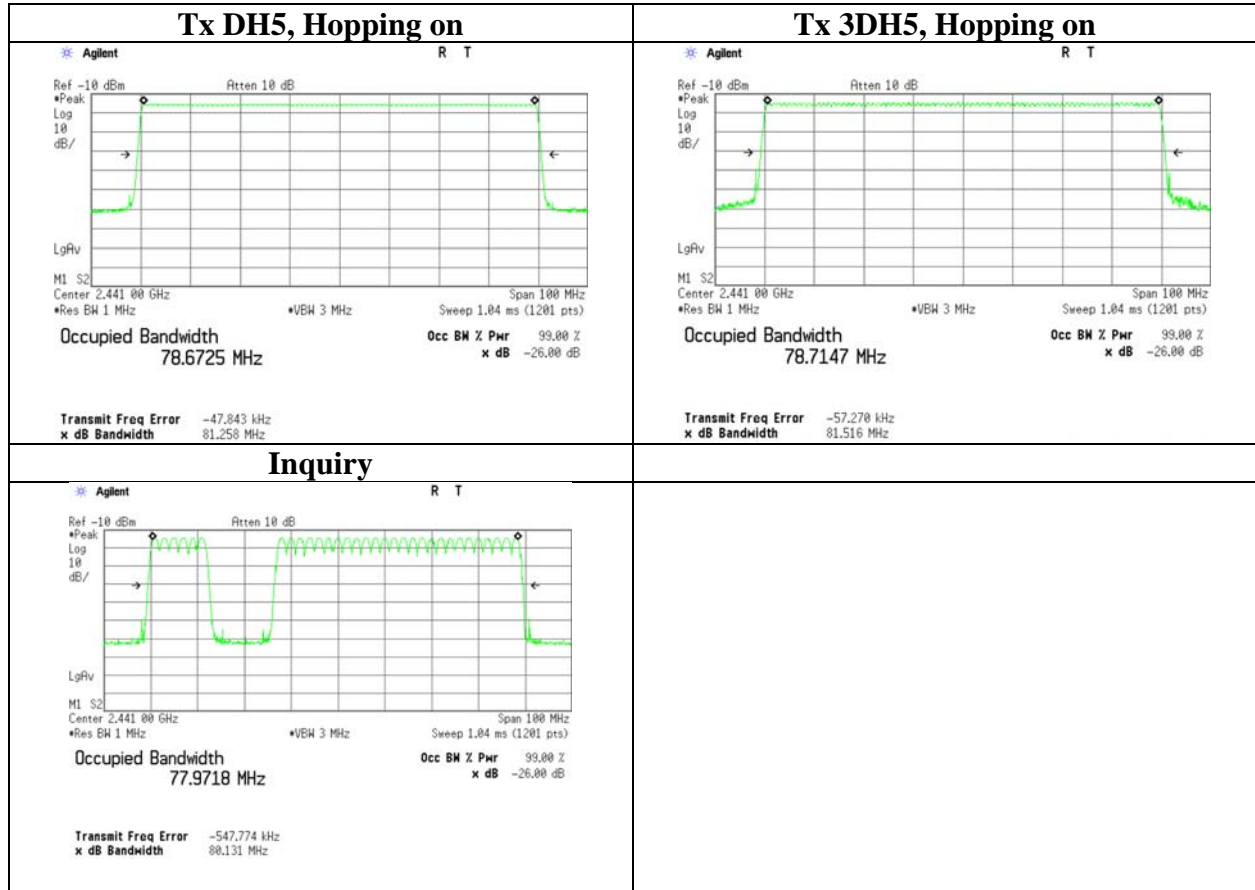



## APPENDIX 2: Test instruments

### EMI test equipment

Control No.	Instrument	Manufacturer	Model No	Serial No	Test Item	Calibration Date * Interval(month)
MAEC-03	Semi Anechoic Chamber(NSA)	TDK	Semi Anechoic Chamber 3m	DA-10005	RE	2015/02/19 * 12
MOS-13	Thermo-Hygrometer	Custom	CTH-180	1301	RE	2015/01/13 * 12
MJM-16	Measure	KOMELON	KMC-36	-	RE	-
COTS-MEMI	EMI measurement program	TSJ	TEPTO-DV	-	RE	-
MSA-03	Spectrum Analyzer	Agilent	E4448A	MY44020357	RE	2014/04/08 * 12
MHA-20	Horn Antenna 1-18GHz	Schwarzbeck	BBHA9120D	258	RE	2014/05/26 * 12
MCC-167	Microwave Cable	Junkosha	MWX221	1404S374(1m) / 1405S074(5m)	RE	2014/05/26 * 12
MPA-11	MicroWave System Amplifier	Agilent	83017A	MY39500779	RE	2014/03/24 * 12
MHF-25	High Pass Filter 3.5-18.0GHz	UL Japan	HPF SELECTOR	001	RE	2014/09/22 * 12
MHA-16	Horn Antenna 15-40GHz	Schwarzbeck	BBHA9170	BBHA9170306	RE	2014/05/26 * 12
MHF-22	High Pass Filter 7-20GHz	TOKIMEC	TF37NCCB	602	RE	2015/01/27 * 12
MCC-79	Microwave Cable 1G-26.5GHz	Suhner	SUCOFLEX104	278923/4	RE	2014/12/15 * 12
MTR-08	Test Receiver	Rohde & Schwarz	ESCI	100767	RE	2014/08/19 * 12
MBA-03	Biconical Antenna	Schwarzbeck	BBA9106	1915	RE	2014/10/18 * 12
MLA-03	Logperiodic Antenna	Schwarzbeck	USLP9143	174	RE	2014/10/18 * 12
MCC-51	Coaxial cable	UL Japan	-	-	RE	2014/07/14 * 12
MAT-70	Attenuator(6dB)	Agilent	8491A-006	MY52460153	RE	2014/04/14 * 12
MPA-13	Pre Amplifier	SONOMA INSTRUMENT	310	260834	RE	2015/03/10 * 12
MRENT-116	Spectrum Analyzer	Agilent	E4440A	MY46187620	AT	2015/03/09 * 12
MPM-12	Power Meter	Anritsu	ML2495A	0825002	AT	2014/06/16 * 12
MPSE-17	Power sensor	Anritsu	MA2411B	0738285	AT	2014/06/16 * 12
MPSE-22	Power sensor	Agilent	N1923A	MY54070003	AT	2014/04/04 * 12
MPM-16	Power Meter	Agilent	8990B	MY51000271	AT	2014/04/04 * 12
MAT-23	Attenuator(10dB) 1-18GHz	Orient Microwave	BX10-0476-00	-	AT	2014/03/13 * 12
MCC-66	Microwave Cable 1G-40GHz	Suhner	SUCOFLEX102	28636/2	AT	2014/04/09 * 12
MOS-19	Thermo-Hygrometer	Custom	CTH-201	0001	AT	2014/12/22 * 12
MCC-38	Coaxial Cable	UL Japan	-	-	AT	2014/12/02 * 12
MAT-10	Attenuator(10dB)	Weinschel Corp	2	BL1173	AT	2014/11/19 * 12
MSA-16	Spectrum Analyzer	Agilent	E4440A	MY46186390	AT	2015/02/16 * 12

### **UL Japan, Inc.**

#### **Ise EMC Lab.**

4383-326 Asama-cho, Ise-shi, Mie-ken 516-0021 JAPAN

Telephone : +81 596 24 8999

Facsimile : +81 596 24 8124

The expiration date of the calibration is the end of the expired month.  
All equipment is calibrated with valid calibrations. Each measurement data is traceable to the national or international standards.

As for some calibrations performed after the tested dates, those test equipment have been controlled by means of an unbroken chains of calibrations.

Test Item: **RE: Radiated Emission**  
**AT: Antenna Terminal Conducted test**