



# RADIO TEST REPORT

**Test Report No. : 12210965H-A-R1**

**Applicant** : MITSUBISHI ELECTRIC CORPORATION SANDA WORKS  
**Type of Equipment** : DISPLAY AUDIO  
**Model No.** : NR-201  
**FCC ID** : UJHNR201  
**Test regulation** : FCC Part 15 Subpart C: 2018  
**Test Result** : Complied

1. This test report shall not be reproduced in full or partial, without the written approval of UL Japan, Inc.
2. The results in this report apply only to the sample tested.
3. This sample tested is in compliance with the above regulation.
4. The test results in this report are traceable to the national or international standards.
5. This test report covers Radio technical requirements. It does not cover administrative issues such as Manual or non-Radio test related Requirements. (if applicable)
6. The all test items in this test report are conducted by UL Japan, Inc. Ise EMC Lab.
7. This test report must not be used by the customer to claim product certification, approval, or endorsement by NVLAP, NIST, or any agency of the Federal Government.
8. This report is a revised version of 12210965H-A. 12210965H-A is replaced with this report.

**Date of test:** March 19 to 27, 2018

**Representative test engineer:**

  
Tomoki Matsui  
Engineer  
Consumer Technology Division

**Approved by:**

  
Tsubasa Takayama  
Leader  
Consumer Technology Division

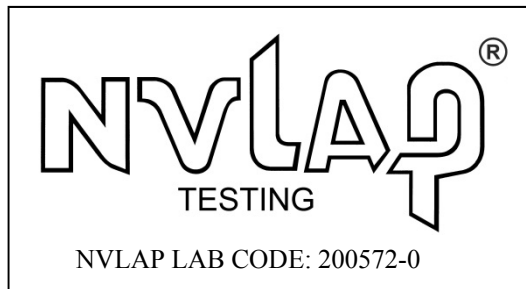

This laboratory is accredited by the NVLAP LAB CODE 200572-0, U.S.A. The tests reported herein have been performed in accordance with its terms of accreditation. \*As for the range of Accreditation in NVLAP, you may refer to the WEB address, [http://japan.ul.com/resources/emc\\_accruited/](http://japan.ul.com/resources/emc_accruited/)

- The testing in which "Non-accreditation" is displayed is outside the accreditation scopes in UL Japan.  
 There is no testing item of "Non-accreditation".

**UL Japan, Inc.**

**Ise EMC Lab.**

4383-326 Asama-cho, Ise-shi, Mie-ken 516-0021 JAPAN

Telephone : +81 596 24 8999

Facsimile : +81 596 24 8124

13-EM-F0429

## REVISION HISTORY

**Original Test Report No.: 12210965H-A**

Revision	Test report No.	Date	Page revised	Contents
- (Original)	12210965H-A	April 24, 2018	-	-
1	12210965H-A-R1	June 12, 2018	P1	Addition of note 6
1	12210965H-A-R1	June 12, 2018	P4	Correction of Receipt Date of Sample; from March 20, 2018 to March 19, 2018
1	12210965H-A-R1	June 12, 2018	P10	Correction of support equipment information (Item No. C and E)
1	12210965H-A-R1	June 12, 2018	P45	Correction of Photographs of test setup

---

<b>CONTENTS</b>	<b>PAGE</b>
<b>SECTION 1: Customer information.....</b>	<b>4</b>
<b>SECTION 2: Equipment under test (E.U.T.).....</b>	<b>4</b>
<b>SECTION 3: Test specification, procedures &amp; results.....</b>	<b>5</b>
<b>SECTION 4: Operation of E.U.T. during testing.....</b>	<b>8</b>
<b>SECTION 5: Radiated Spurious Emission .....</b>	<b>11</b>
<b>SECTION 6: Antenna Terminal Conducted Tests.....</b>	<b>12</b>
<b>APPENDIX 1: Test data .....</b>	<b>13</b>
20dB Bandwidth, 99%Occupied Bandwidth and Carrier Frequency Separation.....	13
Number of Hopping Frequency .....	17
Dwell time.....	19
Maximum Peak Output Power .....	22
Average Output Power .....	23
Radiated Spurious Emission .....	25
Conducted Spurious Emission .....	36
Conducted Emission Band Edge compliance .....	42
<b>APPENDIX 2: Test instruments .....</b>	<b>44</b>
<b>APPENDIX 3: Photographs of test setup .....</b>	<b>45</b>
Radiated Spurious Emission .....	45

## **SECTION 1: Customer information**

Company Name : MITSUBISHI ELECTRIC CORPORATION SANDA WORKS  
Address : 2-3-33, Miwa, Sanda-city, Hyogo, 669-1513, Japan  
Telephone Number : +81-79-559-3182  
Facsimile Number : +81-79-559-3875  
Contact Person : Kenji Otani

## **SECTION 2: Equipment under test (E.U.T.)**

### **2.1 Identification of E.U.T.**

Type of Equipment : DISPLAY AUDIO  
Model No. : NR-201  
Serial No. : Refer to Section 4, Clause 4.2  
Rating : DC 12 V  
Receipt Date of Sample : March 19, 2018  
Country of Mass-production : Thailand  
Condition of EUT : Engineering prototype  
(Not for Sale: This sample is equivalent to mass-produced items.)  
Modification of EUT : No Modification by the test lab

### **2.2 Product Description**

Model: NR-201 (referred to as the EUT in this report) is a DISPLAY AUDIO.

### **Radio Specification**

	<b>Bluetooth Ver.4.2</b>
Frequency of operation	2402 MHz - 2480 MHz
Type of modulation	FHSS (GFSK, $\pi/4$ -DQPSK, 8-DPSK)
Channel spacing	1 MHz
Antenna type	Inverted F Antenna
Antenna Gain	-3.8 dBi
Antenna Connector type	U.FL-LP-066

## **SECTION 3: Test specification, procedures & results**

### **3.1 Test Specification**

Test Specification : FCC Part 15 Subpart C  
FCC Part 15 final revised on March 12, 2018 and effective April 11, 2018

Title : FCC 47CFR Part15 Radio Frequency Device Subpart C Intentional Radiators  
Section 15.207 Conducted limits  
Section 15.247 Operation within the bands 902-928MHz,  
2400-2483.5MHz, and 5725-5850MHz

\* The revision on March 12, 2018, does not affect the test specification applied to the EUT.

### **3.2 Procedures and results**

Item	Test Procedure	Specification	Worst Margin	Results	Remarks
Conducted Emission	FCC: ANSI C63.10-2013 6. Standard test methods IC: RSS-Gen 8.8	FCC: Section 15.207 IC: RSS-Gen 8.8	-	N/A *1)	-
Carrier Frequency Separation	FCC: FCC Public Notice DA 00-705 IC: -	FCC: Section15.247(a)(1) IC: RSS-247 5.1 (b)	See data.	Complied	Conducted
20dB Bandwidth	FCC: FCC Public Notice DA 00-705 IC: -	FCC: Section15.247(a)(1) IC: RSS-247 5.1 (a)		Complied	Conducted
Number of Hopping Frequency	FCC: FCC Public Notice DA 00-705 IC: -	FCC: Section15.247(a)(1)(iii) IC: RSS-247 5.1 (d)		Complied	Conducted
Dwell time	FCC: FCC Public Notice DA 00-705 IC: -	FCC: Section15.247(a)(1)(iii) IC: RSS-247 5.1 (d)		Complied	Conducted
Maximum Peak Output Power	FCC: FCC Public Notice DA 00-705 IC: RSS-Gen 6.12	FCC: Section15.247(a)(b)(1) IC: RSS-247 5.4 (b)		Complied	Conducted
Spurious Emission & Band Edge Compliance	FCC: FCC Public Notice DA 00-705 IC: RSS-Gen 6.13	FCC: Section15.247(d) IC: RSS-247 5.5 RSS-Gen 8.9 RSS-Gen 8.10		5.5 dB 930.999 MHz, Vertical, QP	Complied

Note: UL Japan, Inc.'s EMI Work Procedures No. 13-EM-W0420 and 13-EM-W0422.

\*1) The test is not applicable since the EUT is not the device that is designed to be connected to the public utility (AC) power line.

\*2) Radiated test was selected over 30 MHz based on section 15.247(d).

\* In case any questions arise about test procedure, ANSI C63.10: 2013 is also referred.

#### **FCC Part 15.31 (e)**

This EUT provides the stable voltage constantly to RF Module regardless of input voltage. Therefore, this EUT complies with the requirement.

#### **FCC Part 15.203 Antenna requirement**

It is impossible for end users to replace the antenna, because the antenna is mounted inside of the EUT. Therefore, the equipment complies with the antenna requirement of Section 15.203.

**UL Japan, Inc.**

**Ise EMC Lab.**

4383-326 Asama-cho, Ise-shi, Mie-ken 516-0021 JAPAN

Telephone : +81 596 24 8999

Facsimile : +81 596 24 8124

### 3.3 Addition to standard

Item	Test Procedure	Specification	Worst margin	Results	Remarks
99% Occupied Bandwidth	IC: RSS-Gen 6.6	IC: -	N/A	-	Conducted

Other than above, no addition, exclusion nor deviation has been made from the standard.

### 3.4 Uncertainty

#### EMI

The following uncertainties have been calculated to provide a confidence level of 95 % using a coverage factor  $k=2$ .

#### Radiated emission

Measurement distance	Frequency range	Uncertainty (+/-)
3 m	30 MHz to 200 MHz (Horizontal)	4.8 dB
	(Vertical)	5.0 dB
	200 MHz to 1000 MHz (Horizontal)	5.2 dB
	(Vertical)	6.3 dB
10 m	30 MHz to 200 MHz (Horizontal)	4.8 dB
	(Vertical)	4.9 dB
	200 MHz to 1000 MHz (Horizontal)	5.0 dB
	(Vertical)	5.0 dB
3 m	1 GHz to 6 GHz	5.0 dB
	6 GHz to 18 GHz	5.3 dB
1 m	10 GHz to 26.5 GHz	5.8 dB
	26.5 GHz to 40 GHz	5.8 dB
10 m	1 GHz to 18 GHz	5.2 dB

#### Antenna Terminal test

Test Item	Uncertainty (+/-)
RF output power	1.3 dB
Antenna terminal conducted emission / Power density / Burst power	2.7 dB
Adjacent channel power / Channel power	
Below 3 GHz	1.9 dB
3 GHz to 6 GHz	2.1 dB

#### Radiated emission test

The data listed in this report meets the limits unless the uncertainty is taken into consideration.

### 3.5 Test Location

UL Japan, Inc. Ise EMC Lab.  
4383-326 Asama-cho, Ise-shi, Mie-ken 516-0021 JAPAN  
Telephone: +81 596 24 8999, Facsimile: +81 596 24 8124  
NVLAP Lab. code: 200572-0 / FCC Test Firm Registration Number: 199967

Test site	IC Registration Number	Width x Depth x Height (m)	Size of reference ground plane (m) / horizontal conducting plane	Other rooms	Maximum measurement distance
No.1 semi-anechoic chamber	2973C-1	19.2 x 11.2 x 7.7	7.0 x 6.0	No.1 Power source room	10 m
No.2 semi-anechoic chamber	2973C-2	7.5 x 5.8 x 5.2	4.0 x 4.0	-	3 m
No.3 semi-anechoic chamber	2973C-3	12.0 x 8.5 x 5.9	6.8 x 5.75	No.3 Preparation room	3 m
No.3 shielded room	-	4.0 x 6.0 x 2.7	N/A	-	-
No.4 semi-anechoic chamber	2973C-4	12.0 x 8.5 x 5.9	6.8 x 5.75	No.4 Preparation room	3 m
No.4 shielded room	-	4.0 x 6.0 x 2.7	N/A	-	-
No.5 semi-anechoic chamber	-	6.0 x 6.0 x 3.9	6.0 x 6.0	-	-
No.6 shielded room	-	4.0 x 4.5 x 2.7	4.0 x 4.5	-	-
No.6 measurement room	-	4.75 x 5.4 x 3.0	4.75 x 4.15	-	-
No.7 shielded room	-	4.7 x 7.5 x 2.7	4.7 x 7.5	-	-
No.8 measurement room	-	3.1 x 5.0 x 2.7	N/A	-	-
No.9 measurement room	-	8.8 x 4.6 x 2.8	2.4 x 2.4	-	-
No.11 measurement room	-	6.2 x 4.7 x 3.0	4.8 x 4.6	-	-

\* Size of vertical conducting plane (for Conducted Emission test) : 2.0 m x 2.0 m for No.1, No.2, No.3, and No.4 semi-anechoic chambers and No.3 and No.4 shielded rooms.

### 3.6 Test data, Test instruments, and Test set up

Refer to APPENDIX.

## **SECTION 4: Operation of E.U.T. during testing**

### **4.1 Operating Mode(s)**

Bluetooth (BT): Transmitting (Tx), Payload: PRBS9

Details of Operating Mode(s)

<b>Test Item</b>	<b>Mode</b>	<b>Tested frequency</b>
Spurious Emission (Conducted/Radiated)	Tx (Hopping Off) DH5, 3DH5	2402 MHz 2441 MHz 2480 MHz
Carrier Frequency Separation	Tx (Hopping On) DH5, 3DH5	2402 MHz 2441 MHz 2480 MHz
20dB Bandwidth	Tx (Hopping Off) DH5, 3DH5	2402 MHz 2441 MHz 2480 MHz
Number of Hopping Frequency	Tx (Hopping On) DH5, 3DH5	-
Dwell time	Tx (Hopping On), -DH1, DH3, DH5 -3DH1, 3DH3, 3DH5	-
Maximum Peak Output Power	Tx (Hopping Off) DH5, 2DH5, 3DH5	2402 MHz 2441 MHz 2480 MHz
Band Edge Compliance (Conducted)	Tx DH5, 3DH5 -Hopping On -Hopping Off	2402 MHz 2480 MHz
99% Occupied Bandwidth	Tx DH5, 3DH5 -Hopping On -Hopping Off	2402 MHz 2441 MHz 2480 MHz
<p>*As a result of preliminary test, the formal test was performed with the above modes, which had the maximum payload length (except Dwell time test)</p> <p>*2DH mode (2Mb/s EDR: pi/4DQPSK) was excluded for other tests than power measurement by using 3DH mode (3 Mb/s EDR: 8DPSK) as a representative.</p> <p>* It is considered that the non-tested packet type (e.g. inquiry) can be omitted as it is complied with above all the test items based on Bluetooth Core specification.</p> <p>*EUT has the power settings by the software as follows;  Power settings: BDR / EDR : 0 dBm  Software: Dut labtool ver 2.0.0.89</p> <p>*This setting of software is the worst case.  Any conditions under the normal use do not exceed the condition of setting.  In addition, end users cannot change the settings of the output power of the product.</p>		



## 4.2 Configuration and peripherals

### < Antenna Terminal Conducted Tests >

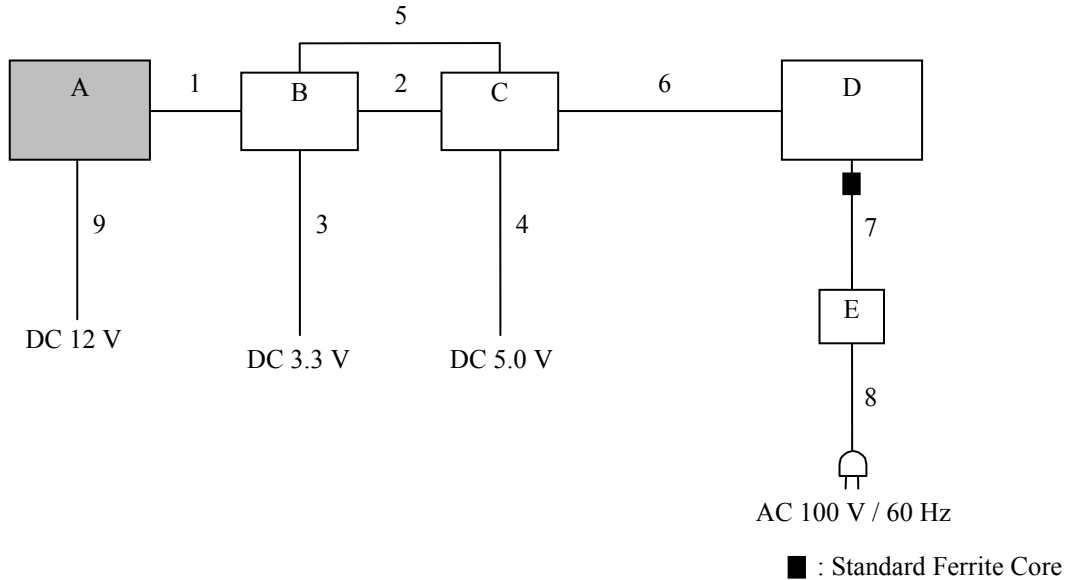

\* Cabling and setup(s) were taken into consideration and test data was taken under worse case conditions.

#### Description of EUT and Support equipment

No.	Item	Model number	Serial number	Manufacturer	Remark
A	DISPLAY AUDIO	NR-201	6014	MITSUBISHI ELECTRIC CORPORATION SANDA WORKS	EUT
B	Jig	-	-	-	-
C	Jig	-	-	-	-
D	Laptop PC	CF-N8HWCDPS	0BKSA08723	Panasonic	-
E	AC Adapter	CF-AA6372B	6372BM409X18054B	Panasonic	-

#### List of cables used

No.	Name	Length (m)	Shield		Remark
			Cable	Connector	
1	Flat Cable	0.3	Unshielded	Unshielded	-
2	Signal Cable	0.2	Unshielded	Unshielded	-
3	DC Cable	2.0	Unshielded	Unshielded	-
4	DC Cable	2.0	Unshielded	Unshielded	-
5	USB Cable	1.8	Shielded	Shielded	-
6	LAN Cable	2.0	Unshielded	Unshielded	-
7	DC Cable	1.1	Unshielded	Unshielded	-
8	AC Cable	0.9	Unshielded	Unshielded	-
9	DC Cable	2.5	Unshielded	Unshielded	-

**UL Japan, Inc.**

**Ise EMC Lab.**

4383-326 Asama-cho, Ise-shi, Mie-ken 516-0021 JAPAN

Telephone : +81 596 24 8999

Facsimile : +81 596 24 8124

< Radiated Emission Test >

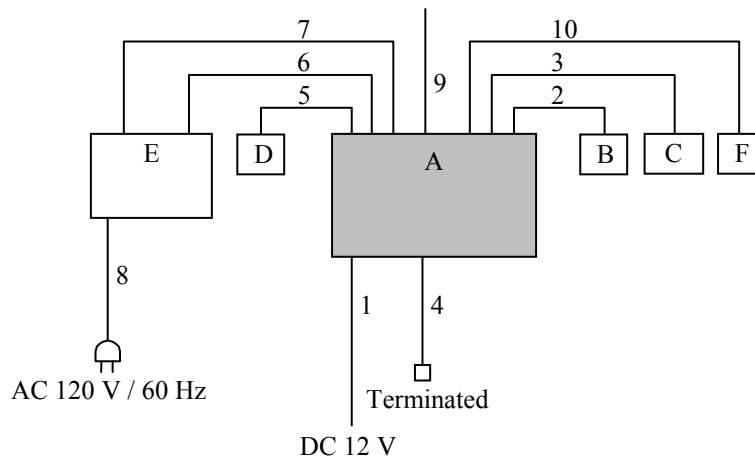

\* Cabling and setup(s) were taken into consideration and test data was taken under worse case conditions.

**Description of EUT and Support equipment**

No.	Item	Model number	Serial number	Manufacturer	Remark
A	DISPLAY AUDIO	NR-201	83146003	mitsubishi electric corporation sanda works	EUT
B	Load ( 4Ω )	L50J4R0	-	-	-
C	USB Memory	JV16GS_BK	120301	Buffalo	-
D	USB Memory	USM4GR B	-	SONY	-
E	DVD Player	DV-600AV-s	HEKD13328LS	Pioneer	-
F	GPS Antenna	DA15-D071-00	A360668	MinebeaMitsumi	-

**List of cables used**

No.	Name	Length (m)	Shield		Remark
			Cable	Connector	
1	DC Cable	2.5	Unshielded	Unshielded	-
2	Speaker Cable	0.8	Unshielded	Unshielded	-
3	USB Cable	3.0	Shielded	Shielded	-
4	AM / FM Cable	0.5	Shielded	Shielded	-
5	USB Cable	1.5	Shielded	Shielded	-
6	HDMI Cable	4.8	Shielded	Shielded	-
7	Video Cable	5.0	Shielded	Shielded	-
8	AC Cable	2.0	Unshielded	Unshielded	-
9	Signal Cable	0.5	Unshielded	Unshielded	-
10	GPS Cable	1.8	Shielded	Shielded	-

**UL Japan, Inc.**

**Ise EMC Lab.**

4383-326 Asama-cho, Ise-shi, Mie-ken 516-0021 JAPAN

Telephone : +81 596 24 8999

Facsimile : +81 596 24 8124

## **SECTION 5: Radiated Spurious Emission**

### **Test Procedure**

[For below 1 GHz]

EUT was placed on a urethane platform of nominal size, 1.0 m by 1.5 m, raised 0.8 m above the conducting ground plane. The Radiated Electric Field Strength has been measured in a Semi Anechoic Chamber with a ground plane.

[For above 1 GHz]

EUT was placed on a urethane platform of nominal size, 0.5 m by 0.5 m, raised 1.5 m above the conducting ground plane.

The Radiated Electric Field Strength has been measured in a Semi Anechoic Chamber with absorbent materials lined on a ground plane.

The height of the measuring antenna varied between 1 and 4 m and EUT was rotated a full revolution in order to obtain the maximum value of the electric field strength.

The measurements were performed for both vertical and horizontal antenna polarization with the Test Receiver, or the Spectrum Analyzer.

The measurements were made with the following detector function of the test receiver and the Spectrum analyzer (in linear mode).

The test was made with the detector (RBW/VBW) in the following table.

When using Spectrum analyzer, the test was made with adjusting span to zero by using peak hold.

### **Test Antennas are used as below;**

Frequency	30 MHz to 200 MHz	200 MHz to 1 GHz	Above 1 GHz
Antenna Type	Biconical	Logperiodic	Horn

In any 100 kHz bandwidth outside the restricted band in which the spread spectrum intentional radiator is operating, the radio frequency power that is produced by the intentional radiator confirmed 20 dB below that in the 100 kHz bandwidth within the band that contains the highest level of the desired power, based on a radiated measurement.

### **20 dBc was applied to the frequency over the limit of FCC 15.209 / Table 4 of RSS-Gen 8.9 (IC) and outside the restricted band of FCC15.205 / Table 6 of RSS-Gen 8.10 (IC).**

Frequency	Below 1 GHz	Above 1 GHz		20 dBc
Instrument used	Test Receiver	Spectrum Analyzer		Spectrum Analyzer
Detector	QP	PK	AV	PK
IF Bandwidth	BW 120 kHz	RBW: 1 MHz VBW: 3 MHz	RBW: 1 MHz VBW: 10 Hz *1)	RBW: 100 kHz VBW: 300 kHz
Test Distance	3 m	3.75 m*2) (1 GHz - 10 GHz), 1 m*3) (10 GHz - 26.5 GHz)		3.75 m*2) (1 GHz - 10 GHz), 1 m*3) (10 GHz - 26.5 GHz)

\*1) Although DA 00-705 accepts VBW = 10 Hz for AV measurements, it was confirmed that superfluous smoothing was not performed.

\*2) Distance Factor:  $20 \times \log(3.75 \text{ m}/3.0 \text{ m}) = 1.94 \text{ dB}$

\*3) Distance Factor:  $20 \times \log(1.0 \text{ m}/3.0 \text{ m}) = -9.5 \text{ dB}$

The test was made on EUT at the normal use position.

The test results and limit are rounded off to one decimal place, so some differences might be observed.

**Measurement range : 30 MHz - 26.5 GHz**  
**Test data : APPENDIX**  
**Test result : Pass**

**UL Japan, Inc.**

**Ise EMC Lab.**

4383-326 Asama-cho, Ise-shi, Mie-ken 516-0021 JAPAN

Telephone : +81 596 24 8999

Facsimile : +81 596 24 8124

## **SECTION 6: Antenna Terminal Conducted Tests**

### **Test Procedure**

The tests were made with below setting connected to the antenna port.

<b>Test</b>	<b>Span</b>	<b>RBW</b>	<b>VBW</b>	<b>Sweep time</b>	<b>Detector</b>	<b>Trace</b>	<b>Instrument used</b>
20dB Bandwidth	3 MHz	30 kHz	100 kHz	Auto	Peak	Max Hold	Spectrum Analyzer
99% Occupied Bandwidth *1)	Enough width to display emission skirts	1 to 5 % of OBW	Three times of RBW	Auto	Peak	Max Hold	Spectrum Analyzer
Maximum Peak Output Power	-	-	-	Auto	Peak Average *2)	-	Power Meter (Sensor: 50MHz BW)
Carrier Frequency Separation	3 MHz	30 kHz	100 kHz	Auto	Peak	Max Hold	Spectrum Analyzer
Number of Hopping Frequency	30 MHz	300 kHz	1 MHz	Auto	Peak	Max Hold	Spectrum Analyzer
Dwell Time	Zero Span	100 kHz, 1 MHz	300 kHz, 3 MHz	As necessary capture the entire dwell time per hopping channel	Peak	Clear Write	Spectrum Analyzer
Conducted Spurious Emission *3)	9 kHz to 150 kHz	200 Hz	620 Hz	Auto	Peak	Max Hold	Spectrum Analyzer
	150 kHz to 30 MHz	9.1 kHz	27 kHz				
	30 MHz to 25 GHz	100 kHz	300 kHz				
Conducted Spurious Emission Band Edge compliance	10 MHz	100 kHz	300 kHz	Auto	Peak	Max Hold	Spectrum Analyzer

\*1) Peak hold was applied as Worst-case measurement.

\*2) Reference data

\*3) In the frequency range below 30MHz, RBW was narrowed to separate the noise contents.

Then, wide-band noise near the limit was checked separately, however the noise was low enough as shown in the chart.  
(9 kHz - 150 kHz: RBW = 200Hz, 150 kHz - 30 MHz: RBW = 9.1 kHz).

The test results and limit are rounded off to two decimals place, so some differences might be observed.

**Test data** : APPENDIX  
**Test result** : Pass

## APPENDIX 1: Test data

### 20dB Bandwidth, 99%Occupied Bandwidth and Carrier Frequency Separation

Test place Ise EMC Lab. No.11 Measurement Room  
Report No. 12210965H  
Date March 20, 2018  
Temperature / Humidity 23 deg. C / 34 % RH  
Engineer Tomoki Matsui  
Mode Tx, Hopping Off, Tx, Hopping On

Mode	Freq. [MHz]	20dB Bandwidth [MHz]	99% Occupied Bandwidth [MHz]	Carrier Frequency Separation [MHz]	Limit for Carrier Frequency separation [MHz]
DH5	2402.0	0.955	0.858	1.032	$\geq 0.637$
DH5	2441.0	0.958	0.859	1.042	$\geq 0.639$
DH5	2480.0	0.954	0.850	1.002	$\geq 0.636$
DH5	Hopping On	-	78.644	-	-
3DH5	2402.0	1.296	1.170	1.005	$\geq 0.864$
3DH5	2441.0	1.297	1.166	1.000	$\geq 0.865$
3DH5	2480.0	1.297	1.167	1.000	$\geq 0.865$
3DH5	Hopping On	-	78.770	-	-

Limit: For Carrier frequency separation two-thirds of 20dB Bandwidth or 25kHz (whichever is greater).  
No limit applies to 20dB Bandwidth.

**20dB Bandwidth and 99% Occupied Bandwidth**

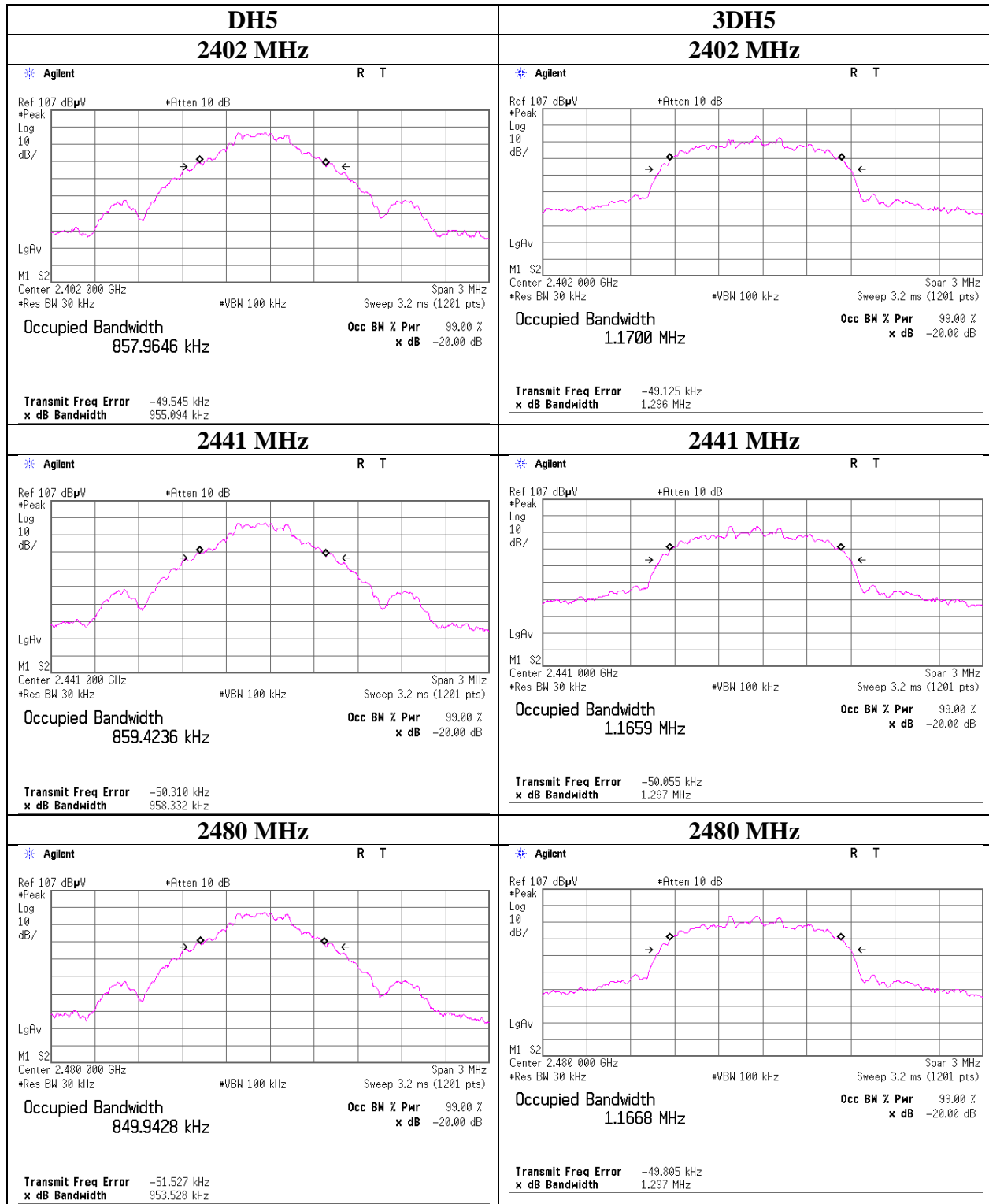

**UL Japan, Inc.**

**Ise EMC Lab.**

4383-326 Asama-cho, Ise-shi, Mie-ken 516-0021 JAPAN

Telephone : +81 596 24 8999

Facsimile : +81 596 24 8124

### 20dB Bandwidth and 99% Occupied Bandwidth

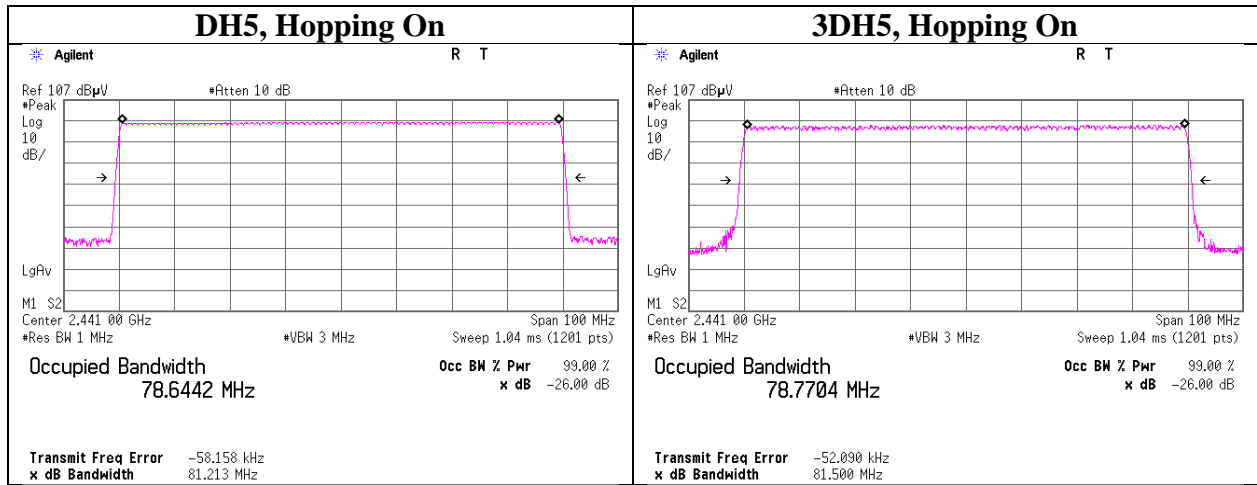

**UL Japan, Inc.**

**Ise EMC Lab.**

4383-326 Asama-cho, Ise-shi, Mie-ken 516-0021 JAPAN

Telephone : +81 596 24 8999

Facsimile : +81 596 24 8124

## Carrier Frequency Separation

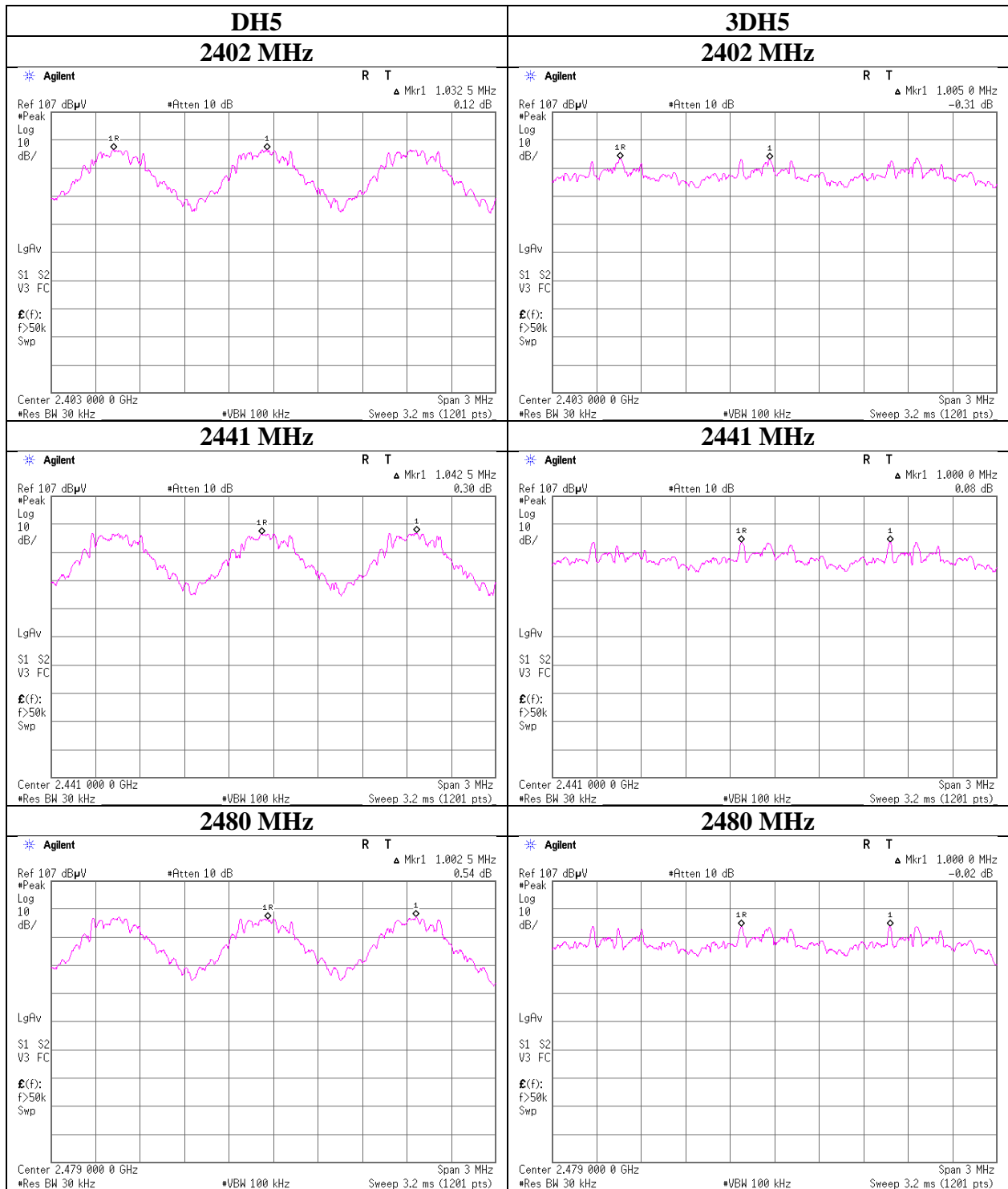

**UL Japan, Inc.**

**Ise EMC Lab.**

4383-326 Asama-cho, Ise-shi, Mie-ken 516-0021 JAPAN

Telephone : +81 596 24 8999

Facsimile : +81 596 24 8124



### Number of Hopping Frequency

Test place Ise EMC Lab. No.11 Measurement Room  
Report No. 12210965H  
Date March 20, 2018  
Temperature / Humidity 23 deg. C / 34 % RH  
Engineer Tomoki Matsui  
Mode Tx, Hopping On

Mode	Number of channel [channels]	Limit [channels]
DH5	79	$\geq 15$
3DH5	79	$\geq 15$

Test was not performed at AFH mode whose number of hopping channel is 20 channels because this Bluetooth radio is in compliance of Bluetooth Specification.

### Number of Hopping Frequency

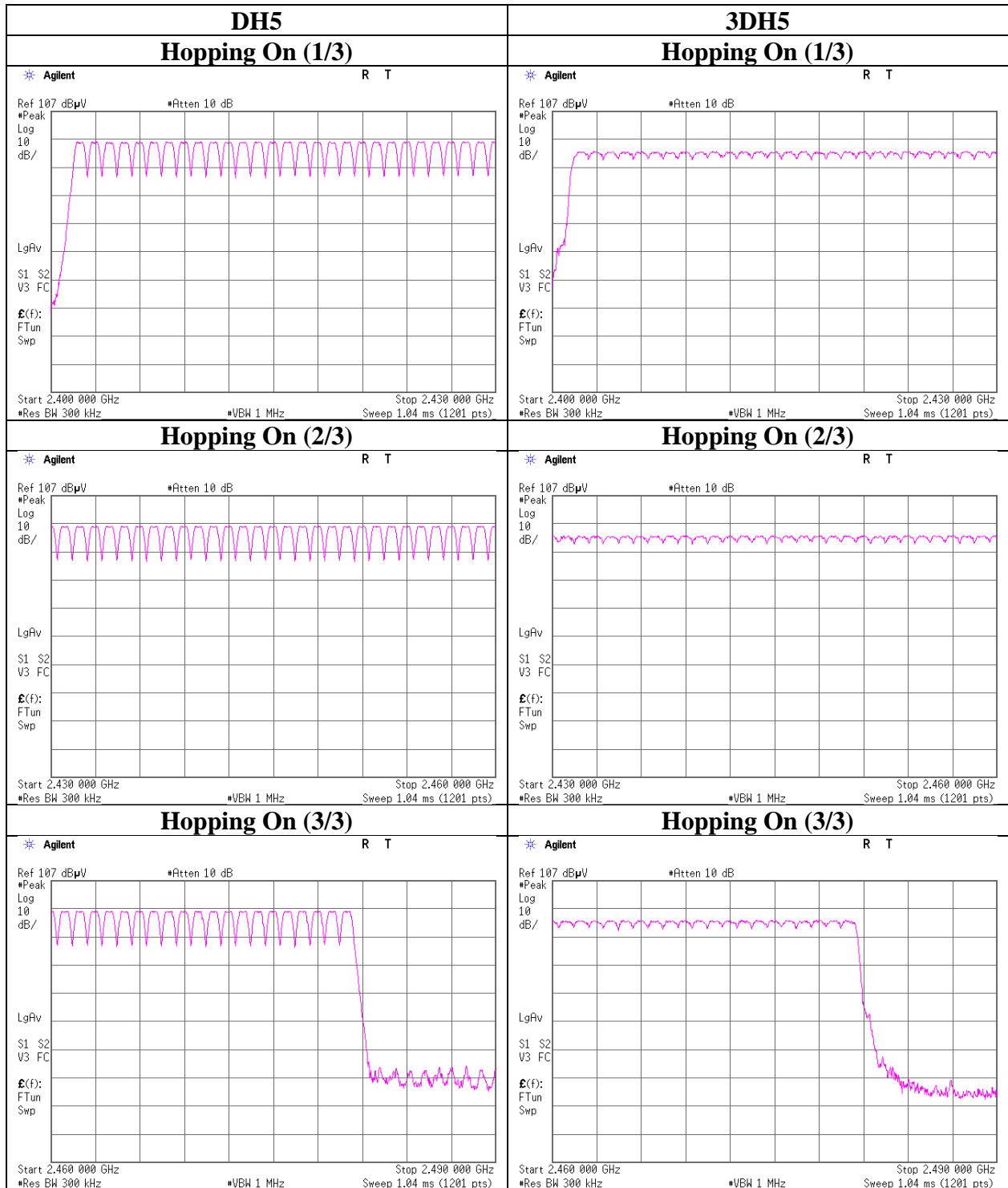

## Dwell time

Test place : Ise EMC Lab. No.11 Measurement Room  
Report No. : 12210965H  
Date : March 20, 2018  
Temperature / Humidity : 23 deg. C / 34 % RH  
Engineer : Tomoki Matsui  
Mode : Tx, Hopping On

Mode	Number of transmission in a 31.6(79 Hopping x 0.4) / 12.8 (32 Hopping x 0.4) second period			Length of transmission [msec]	Result [msec]	Limit [msec]	
DH1	51.8 times /	5 sec. x	31.6 sec. =	328 times	0.412	135	400
DH3	28.0 times /	5 sec. x	31.6 sec. =	177 times	1.669	295	400
DH5	19.4 times /	5 sec. x	31.6 sec. =	123 times	2.936	361	400
3DH1	50.6 times /	5 sec. x	31.6 sec. =	320 times	0.412	132	400
3DH3	24.6 times /	5 sec. x	31.6 sec. =	156 times	1.669	260	400
3DH5	19.6 times /	5 sec. x	31.6 sec. =	124 times	2.940	365	400

Sample Calculation

Result = Number of transmission x Length of transmission

\*Average data of 5 tests.(except Inquiry)

Mode	Sampling [times]					Average [times]
	1	2	3	4	5	
DH1	53	53	50	51	52	51.8
DH3	26	29	24	29	32	28.0
DH5	18	22	16	21	20	19.4
3DH1	51	51	51	50	50	50.6
3DH3	25	26	22	24	26	24.6
3DH5	19	17	20	25	17	19.6

Sample Calculation

Average = Summation (Sampling 1 to 5) / 5

This device complies with the Bluetooth protocol for FHSS operation, employing a pseudo random channel selection and hopping rate to ensure that the occupancy time in  $N \times 0.4s$ , where  $N$  is the number of channels being used in the hopping sequence ( $20 \leq N \leq 79$ ), is always less than  $0.4s$  regardless of packet size. This is confirmed in the test report for  $N = 79$ .

**Dwell time**

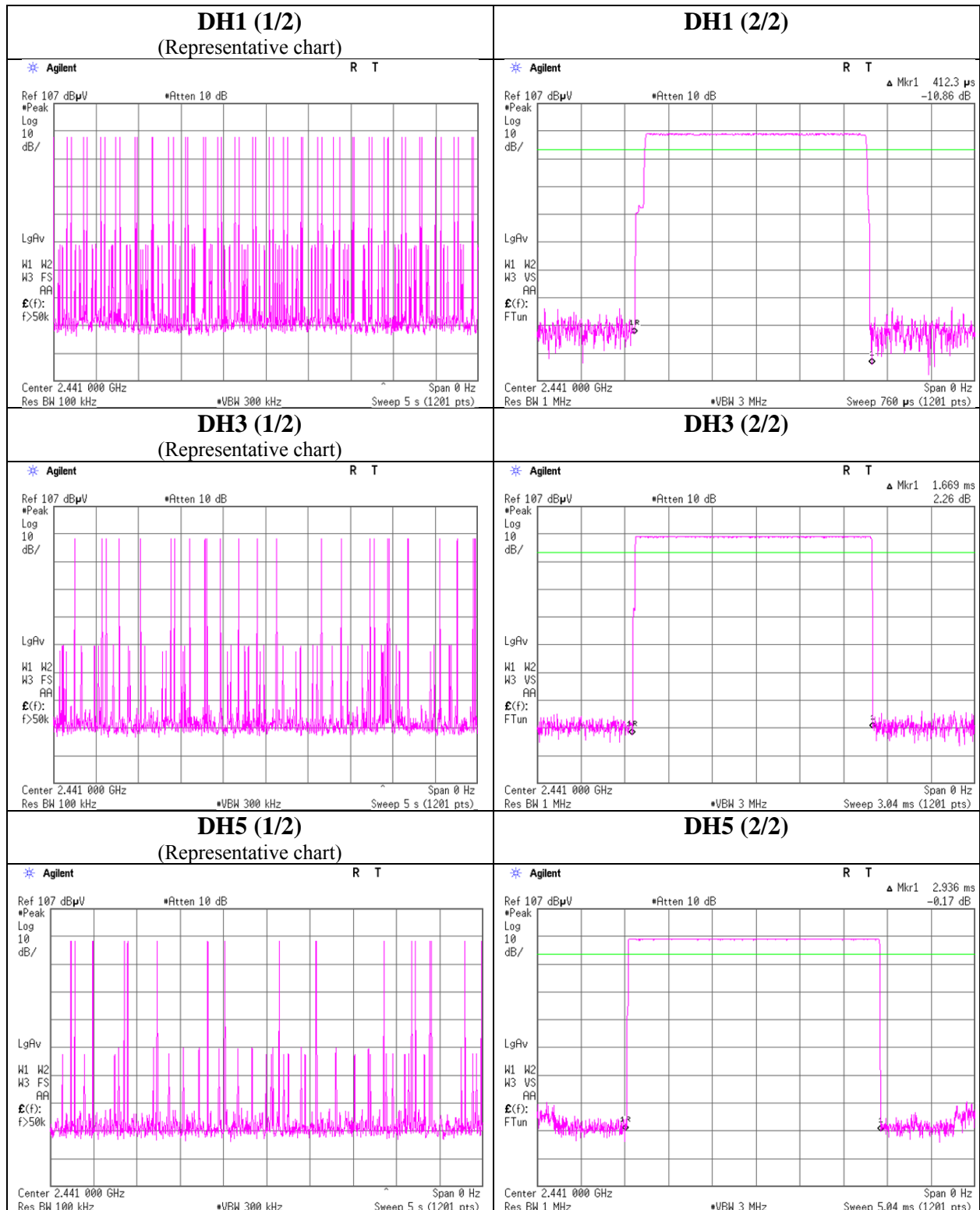

**UL Japan, Inc.**

**Ise EMC Lab.**

4383-326 Asama-cho, Ise-shi, Mie-ken 516-0021 JAPAN

Telephone : +81 596 24 8999

Facsimile : +81 596 24 8124

**Dwell time**

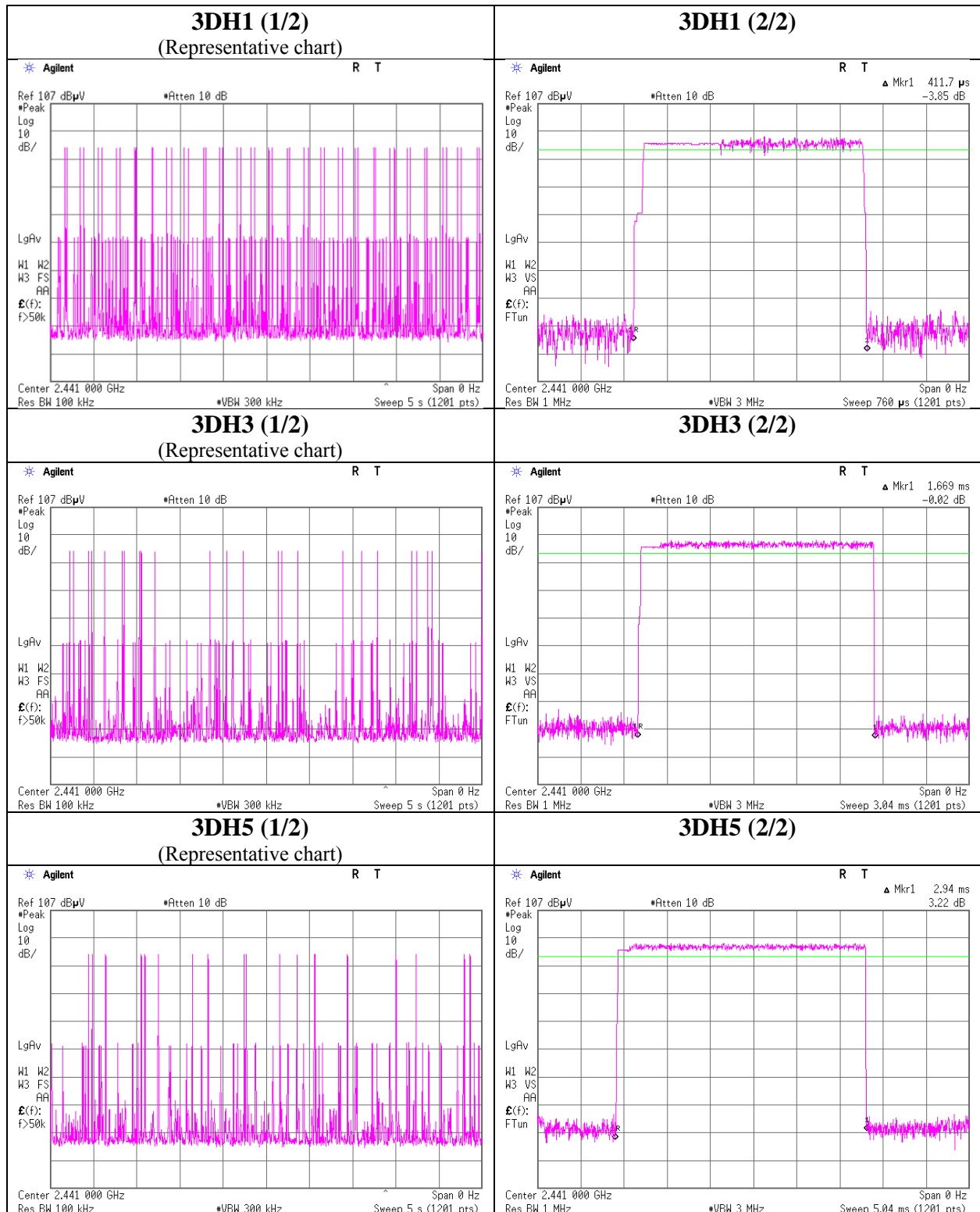

**UL Japan, Inc.**

**Ise EMC Lab.**

4383-326 Asama-cho, Ise-shi, Mie-ken 516-0021 JAPAN

Telephone : +81 596 24 8999

Facsimile : +81 596 24 8124

## Maximum Peak Output Power

Test place : Ise EMC Lab. No.11 Measurement Room  
Report No. : 12210965H  
Date : March 19, 2018  
Temperature / Humidity : 24 deg. C / 32 % RH  
Engineer : Tomoki Matsui  
Mode : Tx, Hopping Off

Mode	Freq. [MHz]	Reading [dBm]	Cable Loss [dB]	Atten. Loss [dB]	Result		Limit		Margin [dB]
					[dBm]	[mW]	[dBm]	[mW]	
DH5	2402.0	-11.00	2.37	10.03	1.40	1.38	20.96	125	19.56
DH5	2441.0	-10.88	2.38	10.03	1.53	1.42	20.96	125	19.43
DH5	2480.0	-10.76	2.39	10.03	1.66	1.47	20.96	125	19.30
2DH5	2402.0	-11.99	2.37	10.03	0.41	1.10	20.96	125	20.55
2DH5	2441.0	-11.83	2.38	10.03	0.58	1.14	20.96	125	20.38
2DH5	2480.0	-11.69	2.39	10.03	0.73	1.18	20.96	125	20.23
3DH5	2402.0	-11.72	2.37	10.03	0.68	1.17	20.96	125	20.28
3DH5	2441.0	-11.57	2.38	10.03	0.84	1.21	20.96	125	20.12
3DH5	2480.0	-11.40	2.39	10.03	1.02	1.26	20.96	125	19.94

Sample Calculation:

Result = Reading + Cable Loss (including the cable(s) customer supplied) + Attenuator Loss

Test was not performed at AFH mode, because the decrease of number of channel (min: 20ch) at AFH mode does not influence on the output power and bandwidth of the EUT.

As this device had AFH mode and frequency separation could not meet the requirement of over 20dB BW without 2/3 relaxation, 125mW power limit was applied to it.

**Average Output Power**  
**(Reference data for RF Exposure)**

Test place : Ise EMC Lab. No.11 Measurement Room  
Report No. : 12210965H  
Date : March 19, 2018  
Temperature / Humidity : 24 deg. C / 32 % RH  
Engineer : Tomoki Matsui  
Mode : Tx, Hopping Off

Mode	Freq. [MHz]	Reading [dBm]	Cable Loss [dB]	Atten. Loss [dB]	Result (Time average)	
					[dBm]	[mW]
DH5	2402.0	-12.33	2.37	10.03	0.07	1.02
DH5	2441.0	-12.18	2.38	10.03	0.23	1.05
DH5	2480.0	-12.06	2.39	10.03	0.36	1.09
2DH5	2402.0	-15.84	2.37	10.03	-3.44	0.45
2DH5	2441.0	-15.67	2.38	10.03	-3.26	0.47
2DH5	2480.0	-15.46	2.39	10.03	-3.04	0.50
3DH5	2402.0	-15.81	2.37	10.03	-3.41	0.46
3DH5	2441.0	-15.65	2.38	10.03	-3.24	0.47
3DH5	2480.0	-15.46	2.39	10.03	-3.04	0.50

Sample Calculation:

Result (Time average) = Reading + Cable Loss (including the cable(s) customer supplied) + Attenuator Loss

### Burst Rate Confirmation

Test place	Ise EMC Lab. No.11 Measurement Room
Report No.	12210965H
Date	March 19, 2018
Temperature / Humidity	24 deg. C / 32 % RH
Engineer	Tomoki Matsui
Mode	Tx, Hopping Off

#### DH5

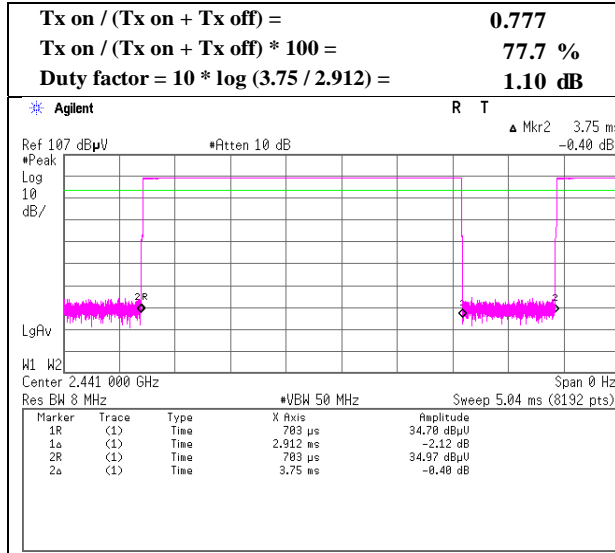

#### 2DH5

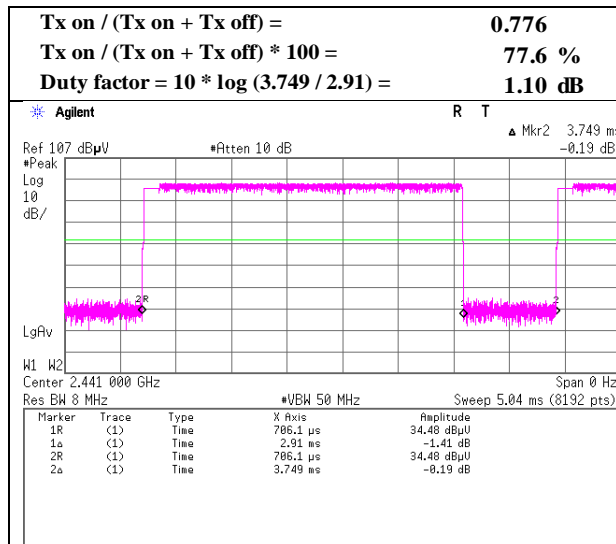

#### 3DH5

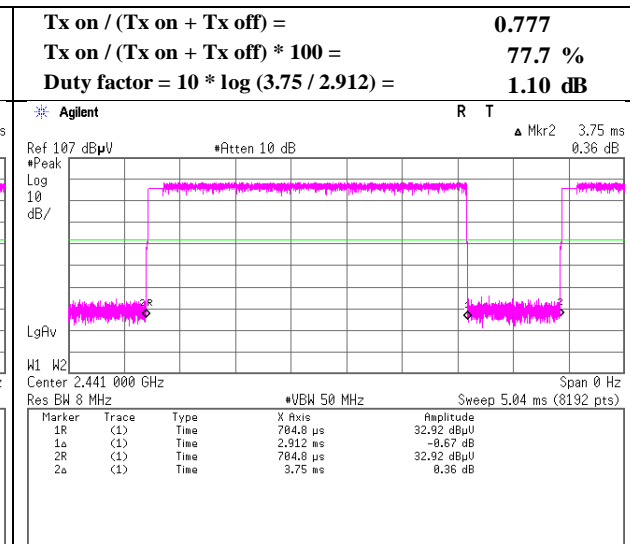



## Radiated Spurious Emission

Report No. 12210965H  
Test place Ise EMC Lab.  
Semi Anechoic Chamber No.3 No.3  
Date March 27, 2018 March 27, 2018  
Temperature / Humidity 24 deg. C / 35 % RH 21 deg. C / 33 % RH  
Engineer Ryota Yamanaka Yuta Moriya  
(Above 1 GHz) (Below 1 GHz)  
Mode Tx, Hopping Off, DH5 2402 MHz

Polarity	Frequency [MHz]	Detector	Reading [dBuV]	Ant.Fac. [dB/m]	Loss [dB]	Gain [dB]	Duty Factor [dB]	Result [dBuV/m]	Limit [dBuV/m]	Margin [dB]	Remark
Hori	65.513	QP	30.5	6.6	7.7	32.2	-	12.6	40.0	27.4	
Hori	76.795	QP	30.9	6.5	7.9	32.2	-	13.1	40.0	26.9	
Hori	441.000	QP	37.7	16.4	11.0	32.0	-	33.1	46.0	12.9	
Hori	587.999	QP	26.3	18.9	11.9	32.0	-	25.1	46.0	20.9	
Hori	832.999	QP	28.8	21.0	13.2	31.3	-	31.7	46.0	14.3	
Hori	930.999	QP	33.7	22.0	13.6	30.8	-	38.5	46.0	7.5	
Hori	2390.000	PK	42.9	27.7	5.1	32.7	-	43.0	73.9	30.9	
Hori	4804.000	PK	40.0	31.6	7.4	31.8	-	47.2	73.9	26.7	Floor noise
Hori	7206.000	PK	41.7	36.0	8.8	32.6	-	53.9	73.9	20.0	Floor noise
Hori	9608.000	PK	42.2	38.5	9.3	33.3	-	56.7	73.9	17.2	Floor noise
Hori	2390.000	AV	29.6	27.7	5.1	32.7	-	29.7	53.9	24.2	
Hori	4804.000	AV	26.8	31.6	7.4	31.8	-	34.0	53.9	19.9	Floor noise
Hori	7206.000	AV	27.9	36.0	8.8	32.6	-	40.1	53.9	13.8	Floor noise
Hori	9608.000	AV	28.3	38.5	9.3	33.3	-	42.8	53.9	11.1	Floor noise
Vert	65.513	QP	46.3	6.6	7.7	32.2	-	28.4	40.0	11.6	
Vert	76.795	QP	38.6	6.5	7.9	32.2	-	20.8	40.0	19.2	
Vert	441.000	QP	35.4	16.4	11.0	32.0	-	30.8	46.0	15.2	
Vert	587.999	QP	36.1	18.9	11.9	32.0	-	34.9	46.0	11.1	
Vert	832.999	QP	28.5	21.0	13.2	31.3	-	31.4	46.0	14.6	
Vert	930.999	QP	35.5	22.0	13.6	30.8	-	40.3	46.0	5.7	
Vert	1584.000	PK	46.1	25.9	4.6	33.8	-	42.8	73.9	31.1	
Vert	1980.000	PK	44.8	26.9	4.9	33.0	-	43.6	73.9	30.3	
Vert	2390.000	PK	42.7	27.7	5.1	32.7	-	42.8	73.9	31.1	
Vert	4804.000	PK	42.2	31.6	7.4	31.8	-	49.4	73.9	24.5	
Vert	7206.000	PK	41.8	36.0	8.8	32.6	-	54.0	73.9	19.9	Floor noise
Vert	9608.000	PK	42.0	38.5	9.3	33.3	-	56.5	73.9	17.4	Floor noise
Vert	1584.000	AV	36.0	25.9	4.6	33.8	-	32.7	53.9	21.2	
Vert	2390.000	AV	28.0	27.7	5.1	32.7	-	28.1	53.9	25.8	
Vert	4804.000	AV	30.3	31.6	7.4	31.8	-	37.5	53.9	16.4	
Vert	7206.000	AV	28.0	36.0	8.8	32.6	-	40.2	53.9	13.7	Floor noise
Vert	9608.000	AV	28.3	38.5	9.3	33.3	-	42.8	53.9	11.1	Floor noise

Result = Reading + Ant Factor + Loss (Cable+Attenuator+Filter+Distance factor(above 1 GHz)) - Gain(Amplifier)

\*Other frequency noises omitted in this report were not seen or had enough margin (more than 20 dB).

Distance factor: 1 GHz - 10 GHz 20log (3.75 m / 3.0 m) = 1.94 dB  
10 GHz - 26.5 GHz 20log (1.0 m / 3.0 m) = -9.5 dB

### 20dBc Data Sheet

Polarity	Frequency [MHz]	Detector	Reading [dBuV]	Ant Factor [dB/m]	Loss [dB]	Gain [dB]	Result [dBuV/m]	Limit [dBuV/m]	Margin [dB]	Remark
Hori	2402.000	PK	89.6	27.7	5.2	32.7	89.8	-	-	Carrier
Hori	2400.000	PK	39.3	27.7	5.2	32.7	39.5	69.8	30.3	
Vert	2402.000	PK	86.3	27.7	5.2	32.7	86.5	-	-	Carrier
Vert	2400.000	PK	35.0	27.7	5.2	32.7	35.2	66.5	31.3	

Result = Reading + Ant Factor + Loss (Cable+Attenuator+Filter+Distance factor(above 1 GHz)) - Gain(Amplifier)

\*These results have sufficient margin without taking account Dwell time factor.

**Radiated Spurious Emission**  
**(Reference Plot for band-edge)**

Report No. 12210965H  
Test place Ise EMC Lab.  
Semi Anechoic Chamber No.3  
Date March 27, 2018  
Temperature / Humidity 24 deg. C / 35 % RH  
Engineer Ryota Yamanaka  
(Above 1 GHz)  
Mode Tx, Hopping Off, DH5 2402 MHz

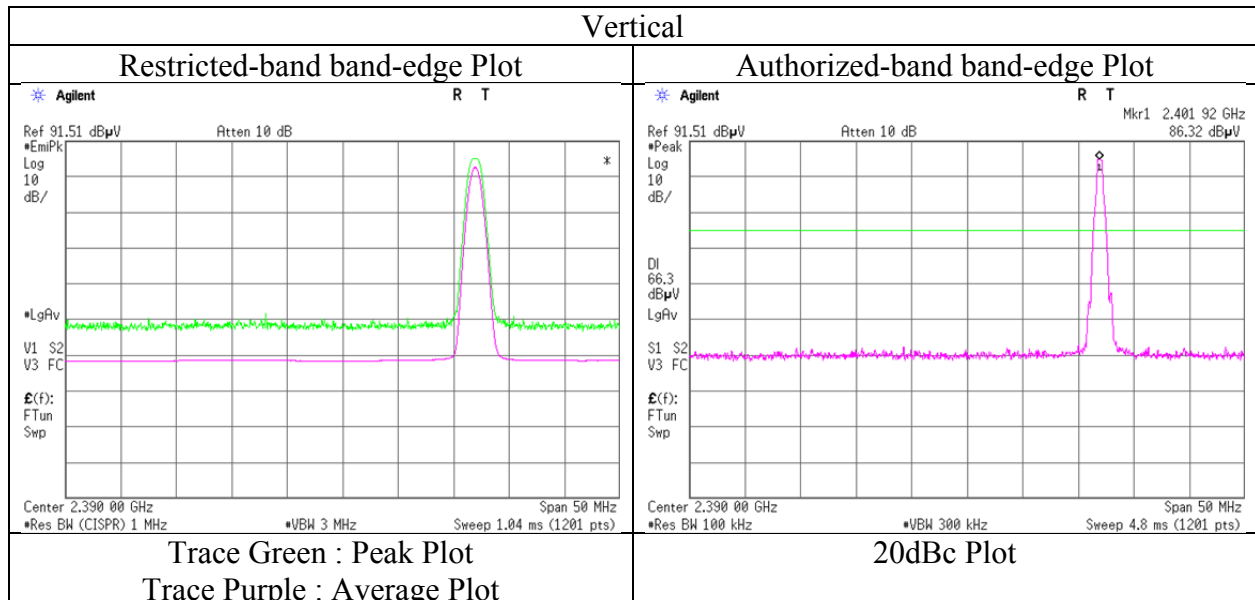
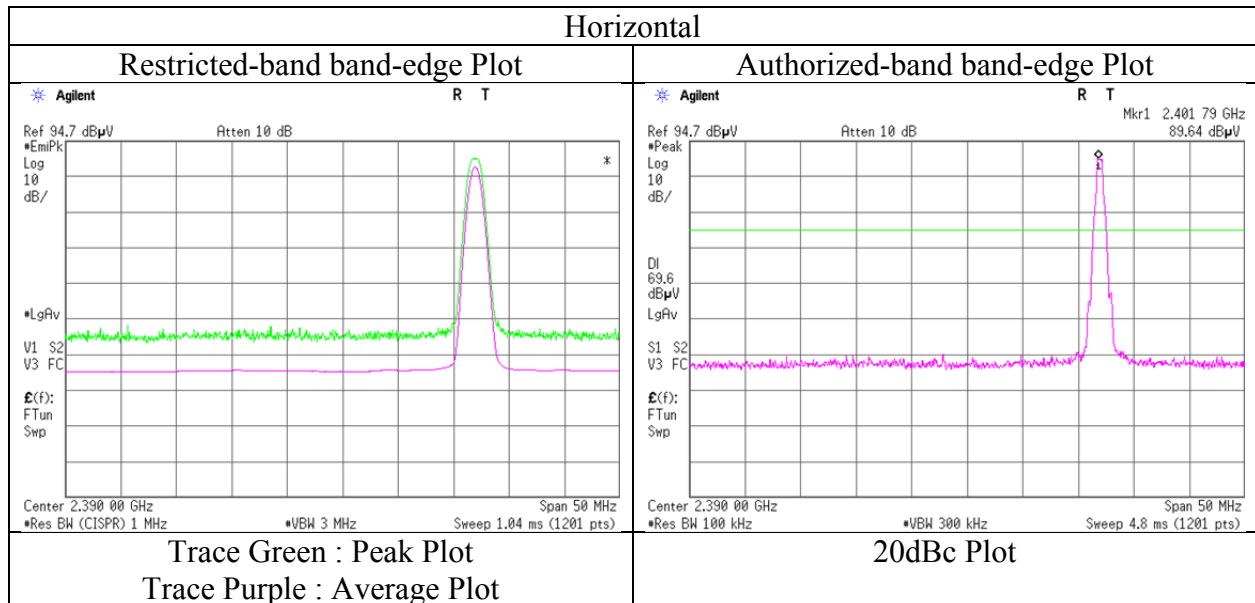

\* Final result of restricted band edge was shown in tabular data.

## Radiated Spurious Emission

Report No. 12210965H  
Test place Ise EMC Lab.  
Semi Anechoic Chamber No.3 No.3  
Date March 27, 2018 March 27, 2018  
Temperature / Humidity 24 deg. C / 35 % RH 21 deg. C / 33 % RH  
Engineer Ryota Yamanaka Yuta Moriya  
(Above 1 GHz) (Below 1 GHz)  
Mode Tx, Hopping Off, DH5 2441 MHz

Polarity	Frequency [MHz]	Detector	Reading [dBuV]	Ant.Fac. [dB/m]	Loss [dB]	Gain [dB]	Duty Factor [dB]	Result [dBuV/m]	Limit [dBuV/m]	Margin [dB]	Remark
Hori	65.513	QP	30.3	6.6	7.7	32.2	-	12.4	40.0	27.6	
Hori	76.795	QP	31.0	6.5	7.9	32.2	-	13.2	40.0	26.8	
Hori	441.000	QP	37.1	16.4	11.0	32.0	-	32.5	46.0	13.5	
Hori	587.999	QP	26.0	18.9	11.9	32.0	-	24.8	46.0	21.2	
Hori	783.999	QP	36.4	20.4	12.9	31.6	-	38.1	46.0	7.9	
Hori	930.999	QP	33.8	22.0	13.6	30.8	-	38.6	46.0	7.4	
Hori	4882.000	PK	40.1	31.9	7.4	31.7	-	47.7	73.9	26.2	Floor noise
Hori	7323.000	PK	41.6	36.2	8.8	32.7	-	53.9	73.9	20.0	Floor noise
Hori	9764.000	PK	41.9	38.7	9.4	33.4	-	56.6	73.9	17.3	Floor noise
Hori	4882.000	AV	28.0	31.9	7.4	31.7	-	35.6	53.9	18.3	Floor noise
Hori	7323.000	AV	29.7	36.2	8.8	32.7	-	42.0	53.9	11.9	Floor noise
Hori	9764.000	AV	29.8	38.7	9.4	33.4	-	44.5	53.9	9.4	Floor noise
Vert	65.513	QP	46.2	6.6	7.7	32.2	-	28.3	40.0	11.7	
Vert	76.795	QP	38.5	6.5	7.9	32.2	-	20.7	40.0	19.3	
Vert	441.000	QP	34.9	16.4	11.0	32.0	-	30.3	46.0	15.7	
Vert	587.999	QP	36.0	18.9	11.9	32.0	-	34.8	46.0	11.2	
Vert	783.999	QP	31.3	20.4	12.9	31.6	-	33.0	46.0	13.0	
Vert	930.999	QP	35.7	22.0	13.6	30.8	-	40.5	46.0	5.5	
Vert	1584.000	PK	44.1	25.9	4.6	33.8	-	40.8	73.9	33.1	
Vert	1980.000	PK	43.2	26.9	4.9	33.0	-	42.0	73.9	31.9	
Vert	4882.000	PK	40.1	31.9	7.4	31.7	-	47.7	73.9	26.2	Floor noise
Vert	7323.000	PK	41.6	36.2	8.8	32.7	-	53.9	73.9	20.0	Floor noise
Vert	9764.000	PK	41.9	38.7	9.4	33.4	-	56.6	73.9	17.3	Floor noise
Vert	1584.000	AV	35.3	25.9	4.6	33.8	-	32.0	53.9	21.9	
Vert	4882.000	AV	28.1	31.9	7.4	31.7	-	35.7	53.9	18.2	Floor noise
Vert	7323.000	AV	29.7	36.2	8.8	32.7	-	42.0	53.9	11.9	Floor noise
Vert	9764.000	AV	29.8	38.7	9.4	33.4	-	44.5	53.9	9.4	Floor noise

Result = Reading + Ant Factor + Loss (Cable+Attenuator+Filter+Distance factor(above 1 GHz)) - Gain(Amplifier)

\*Other frequency noises omitted in this report were not seen or had enough margin (more than 20 dB).

Distance factor: 1 GHz - 10 GHz 20log (3.75 m / 3.0 m) = 1.94 dB  
10 GHz - 26.5 GHz 20log (1.0 m / 3.0 m) = -9.5 dB

**\*These results have sufficient margin without taking account Dwell time factor.**

## Radiated Spurious Emission

Report No. 12210965H  
Test place Ise EMC Lab.  
Semi Anechoic Chamber No.3 No.3  
Date March 27, 2018 March 27, 2018  
Temperature / Humidity 24 deg. C / 35 % RH 21 deg. C / 33 % RH  
Engineer Ryota Yamanaka Yuta Moriya  
(Above 1 GHz) (Below 1 GHz)  
Mode Tx, Hopping Off, DH5 2480 MHz

Polarity	Frequency [MHz]	Detector	Reading [dBuV]	Ant.Fac. [dB/m]	Loss [dB]	Gain [dB]	Duty Factor [dB]	Result [dBuV/m]	Limit [dBuV/m]	Margin [dB]	Remark
Hori	45.013	QP	33.1	12.3	7.4	32.2	-	20.6	40.0	19.4	
Hori	71.709	QP	30.3	6.2	7.8	32.2	-	12.1	40.0	27.9	
Hori	441.000	QP	37.0	16.4	11.0	32.0	-	32.4	46.0	13.6	
Hori	587.999	QP	26.6	18.9	11.9	32.0	-	25.4	46.0	20.6	
Hori	783.999	QP	36.1	20.4	12.9	31.6	-	37.8	46.0	8.2	
Hori	930.999	QP	33.9	22.0	13.6	30.8	-	38.7	46.0	7.3	
Hori	2483.500	PK	43.1	27.8	5.2	32.7	-	43.4	73.9	30.5	
Hori	4960.000	PK	40.0	32.1	7.5	31.7	-	47.9	73.9	26.0	Floor noise
Hori	7440.000	PK	41.5	36.4	8.7	32.7	-	53.9	73.9	20.0	Floor noise
Hori	9920.000	PK	42.0	38.9	9.4	33.4	-	56.9	73.9	17.0	Floor noise
Hori	2483.500	AV	28.8	27.8	5.2	32.7	-	29.1	53.9	24.8	
Hori	4960.000	AV	26.4	32.1	7.5	31.7	-	34.3	53.9	19.6	Floor noise
Hori	7440.000	AV	28.1	36.4	8.7	32.7	-	40.5	53.9	13.4	Floor noise
Hori	9920.000	AV	28.5	38.9	9.4	33.4	-	43.4	53.9	10.5	Floor noise
Vert	45.013	QP	40.2	12.3	7.4	32.2	-	27.7	40.0	12.3	
Vert	71.709	QP	46.2	6.2	7.8	32.2	-	28.0	40.0	12.0	
Vert	441.000	QP	35.0	16.4	11.0	32.0	-	30.4	46.0	15.6	
Vert	587.999	QP	35.9	18.9	11.9	32.0	-	34.7	46.0	11.3	
Vert	783.999	QP	31.4	20.4	12.9	31.6	-	33.1	46.0	12.9	
Vert	930.999	QP	35.4	22.0	13.6	30.8	-	40.2	46.0	5.8	
Vert	1584.000	PK	44.2	25.9	4.6	33.8	-	40.9	73.9	33.0	
Vert	1980.000	PK	43.1	26.9	4.9	33.0	-	41.9	73.9	32.0	
Vert	2483.500	PK	41.8	27.8	5.2	32.7	-	42.1	73.9	31.8	
Vert	4960.000	PK	40.0	32.1	7.5	31.7	-	47.9	73.9	26.0	Floor noise
Vert	7440.000	PK	41.5	36.4	8.7	32.7	-	53.9	73.9	20.0	Floor noise
Vert	9920.000	PK	41.9	38.9	9.4	33.4	-	56.8	73.9	17.1	Floor noise
Vert	1584.000	AV	35.4	25.9	4.6	33.8	-	32.1	53.9	21.8	
Vert	2483.500	AV	28.5	27.8	5.2	32.7	-	28.8	53.9	25.1	
Vert	4960.000	AV	26.4	32.1	7.5	31.7	-	34.3	53.9	19.6	Floor noise
Vert	7440.000	AV	28.0	36.4	8.7	32.7	-	40.4	53.9	13.5	Floor noise
Vert	9920.000	AV	28.5	38.9	9.4	33.4	-	43.4	53.9	10.5	Floor noise

Result = Reading + Ant Factor + Loss (Cable+Attenuator+Filter+Distance factor(above 1 GHz)) - Gain(Amplifier)

\*Other frequency noises omitted in this report were not seen or had enough margin (more than 20 dB).

Distance factor: 1 GHz - 10 GHz  $20\log(3.75\text{ m} / 3.0\text{ m}) = 1.94\text{ dB}$   
10 GHz - 26.5 GHz  $20\log(1.0\text{ m} / 3.0\text{ m}) = -9.5\text{ dB}$

**\*These results have sufficient margin without taking account Dwell time factor.**

**Radiated Spurious Emission**  
**(Reference Plot for band-edge)**

Report No. 12210965H  
Test place Ise EMC Lab.  
Semi Anechoic Chamber No.3  
Date March 27, 2018  
Temperature / Humidity 24 deg. C / 35 % RH  
Engineer Ryota Yamanaka  
(Above 1 GHz)  
Mode Tx, Hopping Off, DH5 2480 MHz

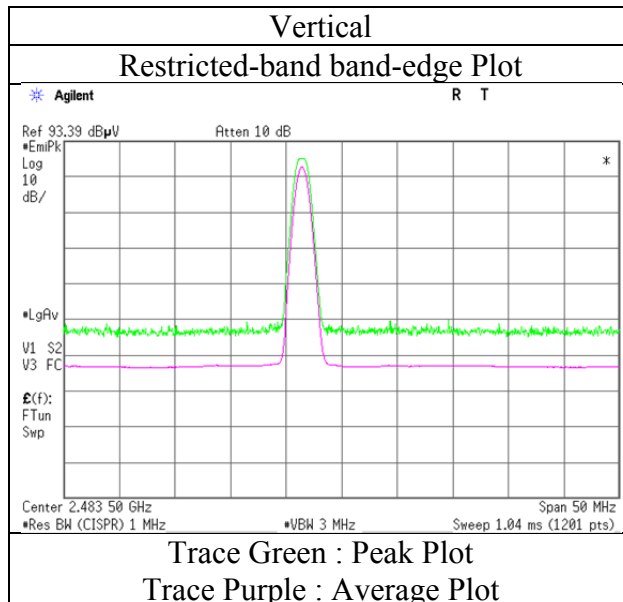
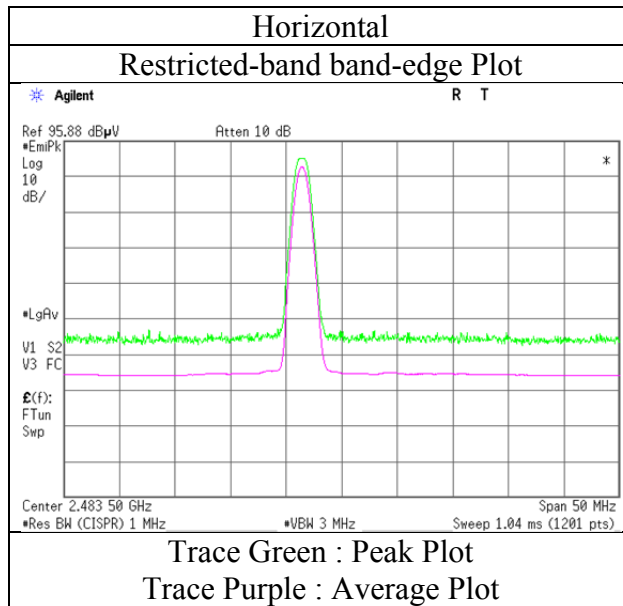

\* Final result of restricted band edge was shown in tabular data.

## Radiated Spurious Emission

Report No. 12210965H  
Test place Ise EMC Lab.  
Semi Anechoic Chamber No.3 No.3  
Date March 27, 2018 March 27, 2018  
Temperature / Humidity 24 deg. C / 35 % RH 21 deg. C / 33 % RH  
Engineer Ryota Yamanaka Yuta Moriya  
(Above 1 GHz) (Below 1 GHz)  
Mode Tx, Hopping Off, 3DH5 2402 MHz

Polarity	Frequency [MHz]	Detector	Reading [dBuV]	Ant.Fac. [dB/m]	Loss [dB]	Gain [dB]	Duty Factor [dB]	Result [dBuV/m]	Limit [dBuV/m]	Margin [dB]	Remark
Hori	45.013	QP	33.2	12.3	7.4	32.2	-	20.7	40.0	19.3	
Hori	71.709	QP	31.0	6.2	7.8	32.2	-	12.8	40.0	27.2	
Hori	441.000	QP	38.8	16.4	11.0	32.0	-	34.2	46.0	11.8	
Hori	587.999	QP	26.6	18.9	11.9	32.0	-	25.4	46.0	20.6	
Hori	783.999	QP	36.1	20.4	12.9	31.6	-	37.8	46.0	8.2	
Hori	930.999	QP	32.0	22.0	13.6	30.8	-	36.8	46.0	9.2	
Hori	2390.000	PK	43.3	27.7	5.1	32.7	-	43.4	73.9	30.5	
Hori	4804.000	PK	40.4	31.6	7.4	31.8	-	47.6	73.9	26.3	Floor noise
Hori	7206.000	PK	41.4	36.0	8.8	32.6	-	53.6	73.9	20.3	Floor noise
Hori	9608.000	PK	42.4	38.5	9.3	33.3	-	56.9	73.9	17.0	Floor noise
Hori	2390.000	AV	28.4	27.7	5.1	32.7	-	28.5	53.9	25.4	
Hori	4804.000	AV	26.7	31.6	7.4	31.8	-	33.9	53.9	20.0	Floor noise
Hori	7206.000	AV	27.9	36.0	8.8	32.6	-	40.1	53.9	13.8	Floor noise
Hori	9608.000	AV	28.2	38.5	9.3	33.3	-	42.7	53.9	11.2	Floor noise
Vert	45.013	QP	39.4	12.3	7.4	32.2	-	26.9	40.0	13.1	
Vert	71.709	QP	46.2	6.2	7.8	32.2	-	28.0	40.0	12.0	
Vert	441.000	QP	36.7	16.4	11.0	32.0	-	32.1	46.0	13.9	
Vert	587.999	QP	36.1	18.9	11.9	32.0	-	34.9	46.0	11.1	
Vert	783.999	QP	30.8	20.4	12.9	31.6	-	32.5	46.0	13.5	
Vert	930.999	QP	34.2	22.0	13.6	30.8	-	39.0	46.0	7.0	
Vert	1584.000	PK	46.0	25.9	4.6	33.8	-	42.7	73.9	31.2	
Vert	1980.000	PK	44.5	26.9	4.9	33.0	-	43.3	73.9	30.6	
Vert	2390.000	PK	42.9	27.7	5.1	32.7	-	43.0	73.9	30.9	
Vert	4804.000	PK	40.0	31.6	7.4	31.8	-	47.2	73.9	26.7	Floor noise
Vert	7206.000	PK	42.4	36.0	8.8	32.6	-	54.6	73.9	19.3	Floor noise
Vert	9608.000	PK	41.9	38.5	9.3	33.3	-	56.4	73.9	17.5	Floor noise
Vert	1584.000	AV	35.9	25.9	4.6	33.8	-	32.6	53.9	21.3	
Vert	2390.000	AV	28.3	27.7	5.1	32.7	-	28.4	53.9	25.5	
Vert	4804.000	AV	26.6	31.6	7.4	31.8	-	33.8	53.9	20.1	Floor noise
Vert	7206.000	AV	28.0	36.0	8.8	32.6	-	40.2	53.9	13.7	Floor noise
Vert	9608.000	AV	28.2	38.5	9.3	33.3	-	42.7	53.9	11.2	Floor noise

Result = Reading + Ant Factor + Loss (Cable+Attenuator+Filter+Distance factor(above 1 GHz)) - Gain(Amplifier)

\*Other frequency noises omitted in this report were not seen or had enough margin (more than 20 dB).

Distance factor: 1 GHz - 10 GHz 20log (3.75 m / 3.0 m) = 1.94 dB  
10 GHz - 26.5 GHz 20log (1.0 m / 3.0 m) = -9.5 dB

### 20dBc Data Sheet

Polarity	Frequency [MHz]	Detector	Reading [dBuV]	Ant Factor [dB/m]	Loss [dB]	Gain [dB]	Result [dBuV/m]	Limit [dBuV/m]	Margin [dB]	Remark
Hori	2402.000	PK	86.8	27.7	5.2	32.7	87.0	-	-	Carrier
Hori	2400.000	PK	40.0	27.7	5.2	32.7	40.2	67.0	26.8	
Vert	2402.000	PK	84.5	27.7	5.2	32.7	84.7	-	-	Carrier
Vert	2400.000	PK	38.1	27.7	5.2	32.7	38.3	64.7	26.4	

Result = Reading + Ant Factor + Loss (Cable+Attenuator+Filter+Distance factor(above 1 GHz)) - Gain(Amplifier)

**\*These results have sufficient margin without taking account Dwell time factor.**

**UL Japan, Inc.**

**Ise EMC Lab.**

4383-326 Asama-cho, Ise-shi, Mie-ken 516-0021 JAPAN

Telephone : +81 596 24 8999

Facsimile : +81 596 24 8124

**Radiated Spurious Emission**  
**(Reference Plot for band-edge)**

Report No. 12210965H  
Test place Ise EMC Lab.  
Semi Anechoic Chamber No.3  
Date March 27, 2018  
Temperature / Humidity 24 deg. C / 35 % RH  
Engineer Ryota Yamanaka  
(Above 1 GHz)  
Mode Tx, Hopping Off, 3DH5 2402 MHz

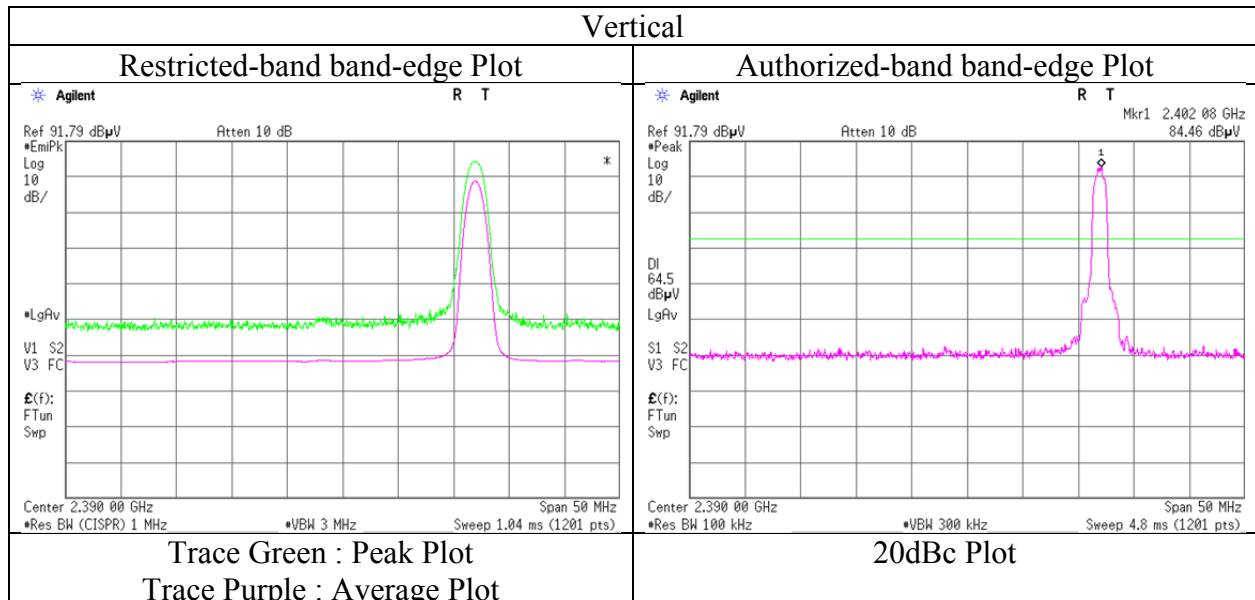
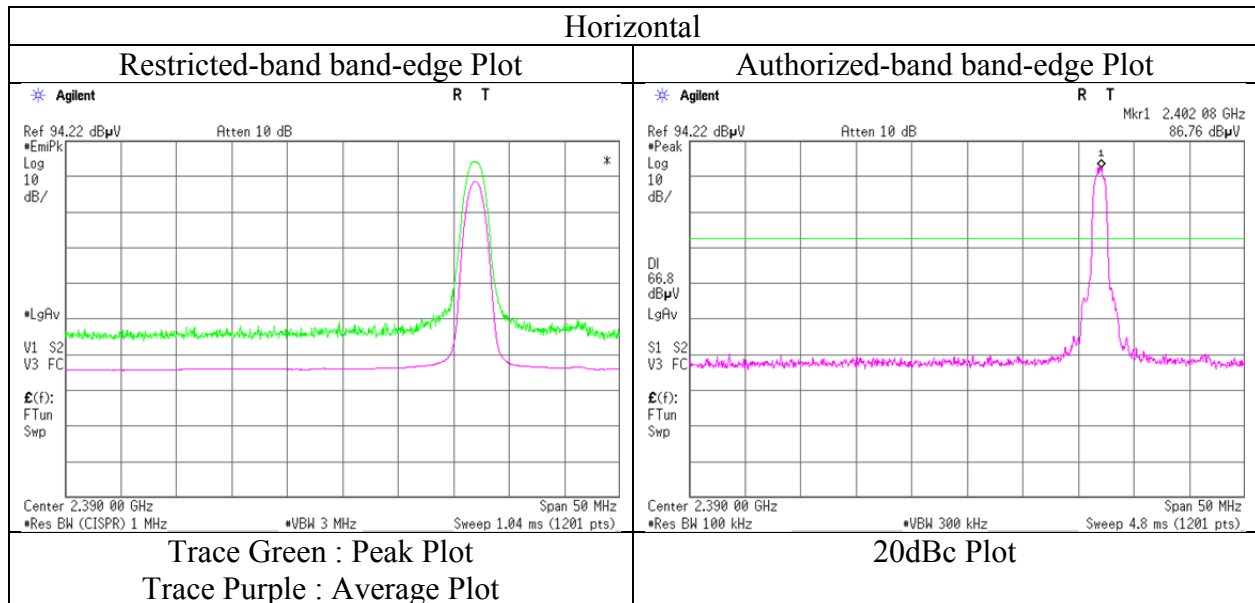

\* Final result of restricted band edge was shown in tabular data.

**UL Japan, Inc.**

**Ise EMC Lab.**

4383-326 Asama-cho, Ise-shi, Mie-ken 516-0021 JAPAN

Telephone : +81 596 24 8999

Facsimile : +81 596 24 8124

## Radiated Spurious Emission

Report No. 12210965H  
Test place Ise EMC Lab.  
Semi Anechoic Chamber No.3 No.3  
Date March 27, 2018 March 27, 2018  
Temperature / Humidity 24 deg. C / 35 % RH 21 deg. C / 33 % RH  
Engineer Ryota Yamanaka Yuta Moriya  
(Above 1 GHz) (Below 1 GHz)  
Mode Tx, Hopping Off, 3DH5 2441 MHz

Polarity	Frequency [MHz]	Detector	Reading [dBuV]	Ant.Fac. [dB/m]	Loss [dB]	Gain [dB]	Duty Factor [dB]	Result [dBuV/m]	Limit [dBuV/m]	Margin [dB]	Remark
Hori	45.013	QP	33.5	12.3	7.4	32.2	-	21.0	40.0	19.0	
Hori	71.709	QP	31.5	6.2	7.8	32.2	-	13.3	40.0	26.7	
Hori	441.000	QP	40.1	16.4	11.0	32.0	-	35.5	46.0	10.5	
Hori	587.999	QP	26.6	18.9	11.9	32.0	-	25.4	46.0	20.6	
Hori	783.999	QP	33.5	20.4	12.9	31.6	-	35.2	46.0	10.8	
Hori	930.999	QP	32.3	22.0	13.6	30.8	-	37.1	46.0	8.9	
Hori	4882.000	PK	40.2	31.9	7.4	31.7	-	47.8	73.9	26.1	Floor noise
Hori	7323.000	PK	41.7	36.2	8.8	32.7	-	54.0	73.9	19.9	Floor noise
Hori	9764.000	PK	42.0	38.7	9.4	33.4	-	56.7	73.9	17.2	Floor noise
Hori	4882.000	AV	28.1	31.9	7.4	31.7	-	35.7	53.9	18.2	Floor noise
Hori	7323.000	AV	29.6	36.2	8.8	32.7	-	41.9	53.9	12.0	Floor noise
Hori	9764.000	AV	29.8	38.7	9.4	33.4	-	44.5	53.9	9.4	Floor noise
Vert	45.013	QP	40.2	12.3	7.4	32.2	-	27.7	40.0	12.3	
Vert	71.709	QP	46.0	6.2	7.8	32.2	-	27.8	40.0	12.2	
Vert	441.000	QP	36.7	16.4	11.0	32.0	-	32.1	46.0	13.9	
Vert	587.999	QP	36.0	18.9	11.9	32.0	-	34.8	46.0	11.2	
Vert	783.999	QP	30.1	20.4	12.9	31.6	-	31.8	46.0	14.2	
Vert	930.999	QP	33.9	22.0	13.6	30.8	-	38.7	46.0	7.3	
Vert	1584.000	PK	44.0	25.9	4.6	33.8	-	40.7	73.9	33.2	
Vert	1980.000	PK	43.1	26.9	4.9	33.0	-	41.9	73.9	32.0	
Vert	4882.000	PK	40.1	31.9	7.4	31.7	-	47.7	73.9	26.2	Floor noise
Vert	7323.000	PK	41.5	36.2	8.8	32.7	-	53.8	73.9	20.1	Floor noise
Vert	9764.000	PK	42.0	38.7	9.4	33.4	-	56.7	73.9	17.2	Floor noise
Vert	1584.000	AV	35.2	25.9	4.6	33.8	-	31.9	53.9	22.0	
Vert	4882.000	AV	28.1	31.9	7.4	31.7	-	35.7	53.9	18.2	Floor noise
Vert	7323.000	AV	29.6	36.2	8.8	32.7	-	41.9	53.9	12.0	Floor noise
Vert	9764.000	AV	29.8	38.7	9.4	33.4	-	44.5	53.9	9.4	Floor noise

Result = Reading + Ant Factor + Loss (Cable+Attenuator+Filter+Distance factor(above 1 GHz)) - Gain(Amplifier)

\*Other frequency noises omitted in this report were not seen or had enough margin (more than 20 dB).

Distance factor: 1 GHz - 10 GHz 20log (3.75 m / 3.0 m) = 1.94 dB  
10 GHz - 26.5 GHz 20log (1.0 m / 3.0 m) = -9.5 dB

**\*These results have sufficient margin without taking account Dwell time factor.**



## Radiated Spurious Emission

Report No. 12210965H  
Test place Ise EMC Lab.  
Semi Anechoic Chamber No.3 No.3  
Date March 27, 2018 March 27, 2018  
Temperature / Humidity 24 deg. C / 35 % RH 21 deg. C / 33 % RH  
Engineer Ryota Yamanaka Yuta Moriya  
(Above 1 GHz) (Below 1 GHz)  
Mode Tx, Hopping Off, 3DH5 2480 MHz

Polarity	Frequency [MHz]	Detector	Reading [dBuV]	Ant.Fac. [dB/m]	Loss [dB]	Gain [dB]	Duty Factor [dB]	Result [dBuV/m]	Limit [dBuV/m]	Margin [dB]	Remark
Hori	45.013	QP	33.5	12.3	7.4	32.2	-	21.0	40.0	19.0	
Hori	71.709	QP	31.5	6.2	7.8	32.2	-	13.3	40.0	26.7	
Hori	441.000	QP	38.7	16.4	11.0	32.0	-	34.1	46.0	11.9	
Hori	587.999	QP	26.6	18.9	11.9	32.0	-	25.4	46.0	20.6	
Hori	783.999	QP	34.0	20.4	12.9	31.6	-	35.7	46.0	10.3	
Hori	930.999	QP	31.3	22.0	13.6	30.8	-	36.1	46.0	9.9	
Hori	2483.500	PK	46.2	27.8	5.2	32.7	-	46.5	73.9	27.4	
Hori	4960.000	PK	39.9	32.1	7.5	31.7	-	47.8	73.9	26.1	Floor noise
Hori	7440.000	PK	41.4	36.4	8.7	32.7	-	53.8	73.9	20.1	Floor noise
Hori	9920.000	PK	42.1	38.9	9.4	33.4	-	57.0	73.9	16.9	Floor noise
Hori	2483.500	AV	29.1	27.8	5.2	32.7	-	29.4	53.9	24.5	
Hori	4960.000	AV	26.5	32.1	7.5	31.7	-	34.4	53.9	19.5	Floor noise
Hori	7440.000	AV	28.0	36.4	8.7	32.7	-	40.4	53.9	13.5	Floor noise
Hori	9920.000	AV	28.4	38.9	9.4	33.4	-	43.3	53.9	10.6	Floor noise
Vert	45.013	QP	39.4	12.3	7.4	32.2	-	26.9	40.0	13.1	
Vert	71.709	QP	44.8	6.2	7.8	32.2	-	26.6	40.0	13.4	
Vert	441.000	QP	36.4	16.4	11.0	32.0	-	31.8	46.0	14.2	
Vert	587.999	QP	35.6	18.9	11.9	32.0	-	34.4	46.0	11.6	
Vert	783.999	QP	30.4	20.4	12.9	31.6	-	32.1	46.0	13.9	
Vert	930.999	QP	33.6	22.0	13.6	30.8	-	38.4	46.0	7.6	
Vert	1584.000	PK	44.1	25.9	4.6	33.8	-	40.8	73.9	33.1	
Vert	1980.000	PK	43.1	26.9	4.9	33.0	-	41.9	73.9	32.0	
Vert	2483.500	PK	45.0	27.8	5.2	32.7	-	45.3	73.9	28.6	
Vert	4960.000	PK	40.0	32.1	7.5	31.7	-	47.9	73.9	26.0	Floor noise
Vert	7440.000	PK	41.6	36.4	8.7	32.7	-	54.0	73.9	19.9	Floor noise
Vert	9920.000	PK	42.0	38.9	9.4	33.4	-	56.9	73.9	17.0	Floor noise
Vert	1584.000	AV	35.4	25.9	4.6	33.8	-	32.1	53.9	21.8	
Vert	2483.500	AV	28.9	27.8	5.2	32.7	-	29.2	53.9	24.7	
Vert	4960.000	AV	26.5	32.1	7.5	31.7	-	34.4	53.9	19.5	Floor noise
Vert	7440.000	AV	28.0	36.4	8.7	32.7	-	40.4	53.9	13.5	Floor noise
Vert	9920.000	AV	28.5	38.9	9.4	33.4	-	43.4	53.9	10.5	Floor noise

Result = Reading + Ant Factor + Loss (Cable+Attenuator+Filter+Distance factor(above 1 GHz)) - Gain(Amplifier)

\*Other frequency noises omitted in this report were not seen or had enough margin (more than 20 dB).

Distance factor: 1 GHz - 10 GHz 20log (3.75 m / 3.0 m) = 1.94 dB  
10 GHz - 26.5 GHz 20log (1.0 m / 3.0 m) = -9.5 dB

**\*These results have sufficient margin without taking account Dwell time factor.**

**Radiated Spurious Emission**  
**(Reference Plot for band-edge)**

Report No. 12210965H  
Test place Ise EMC Lab.  
Semi Anechoic Chamber No.3  
Date March 27, 2018  
Temperature / Humidity 24 deg. C / 35 % RH  
Engineer Ryota Yamanaka  
(Above 1 GHz)  
Mode Tx, Hopping Off, 3DH5 2480 MHz

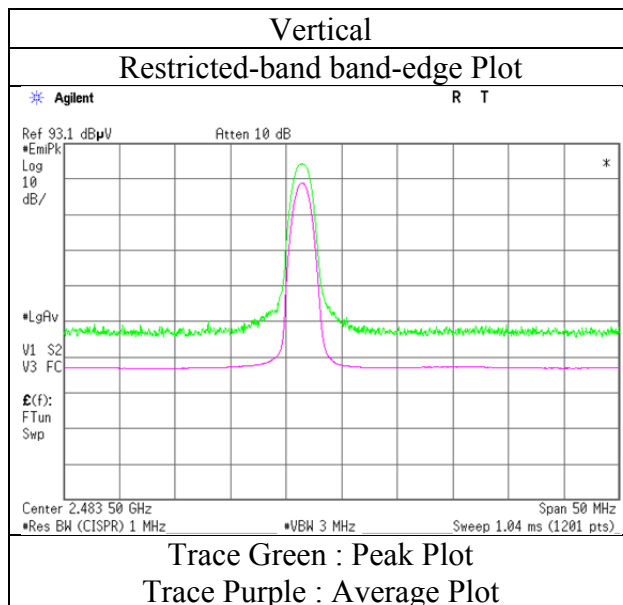
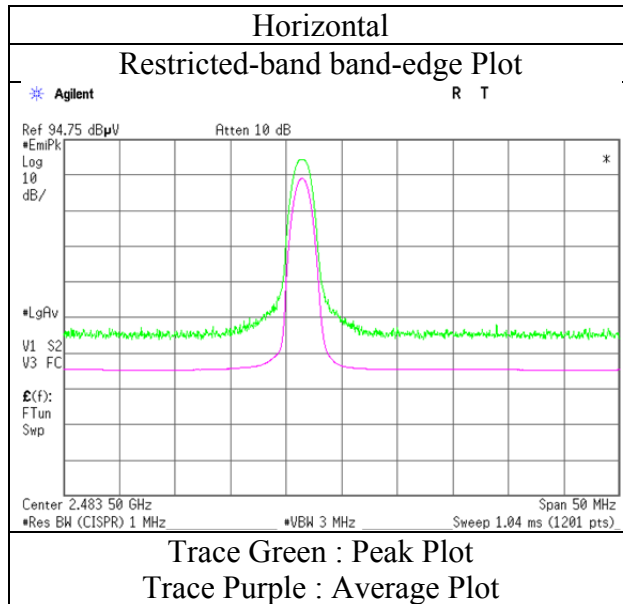

\* Final result of restricted band edge was shown in tabular data.

**Radiated Spurious Emission**  
**(Plot data, Worst case)**

Report No.	12210965H	
Test place	Ise EMC Lab.	
Semi Anechoic Chamber	No.3	No.3
Date	March 27, 2018	March 27, 2018
Temperature / Humidity	24 deg. C / 35 % RH	21 deg. C / 33 % RH
Engineer	Ryota Yamanaka (Above 1 GHz)	Yuta Moriya (Below 1 GHz)
Mode	Tx, Hopping On, DH5 2441 MHz	

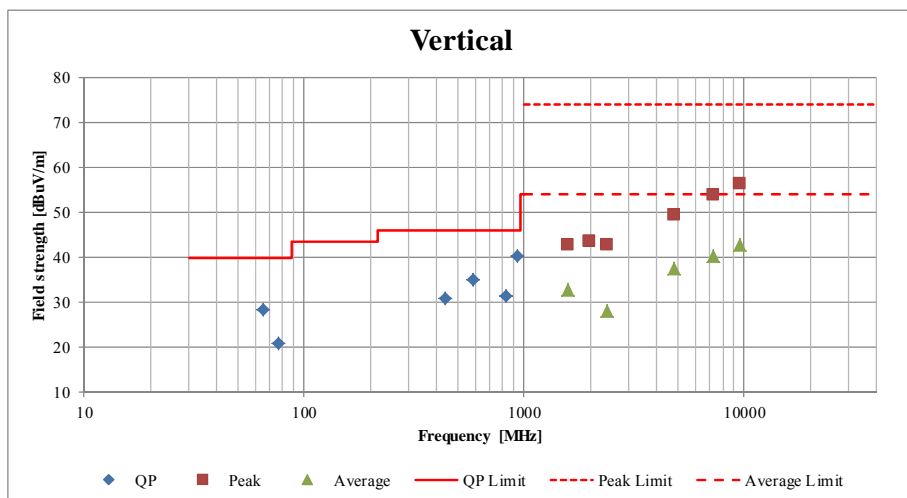
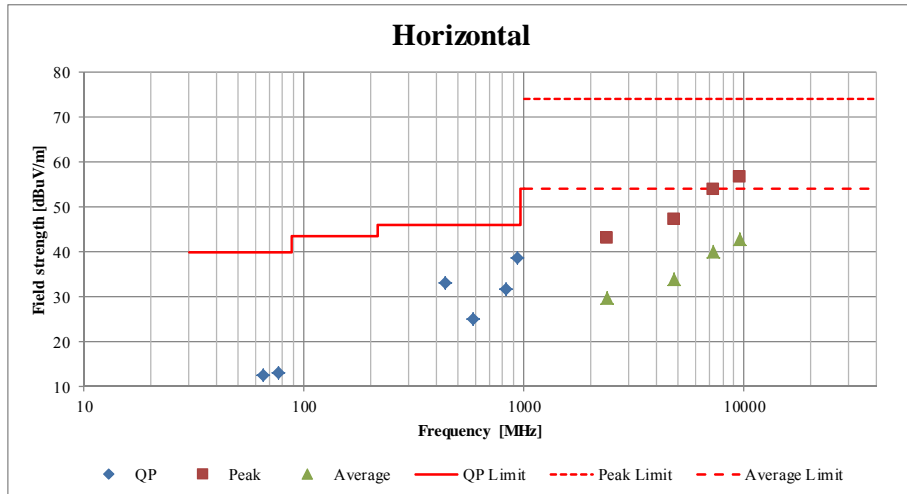

\*These plots data contains sufficient number to show the trend of characteristic features for EUT.

## Conducted Spurious Emission

Test place	Ise EMC Lab. No.11 Measurement Room
Report No.	12210965H
Date	March 19, 2018
Temperature / Humidity	24 deg. C / 32 % RH
Engineer	Tomoki Matsui
Mode	Tx, Hopping Off, DH5

### 2402 MHz

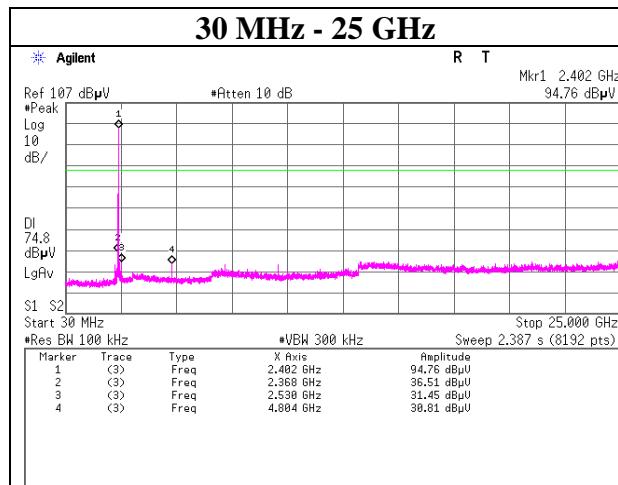
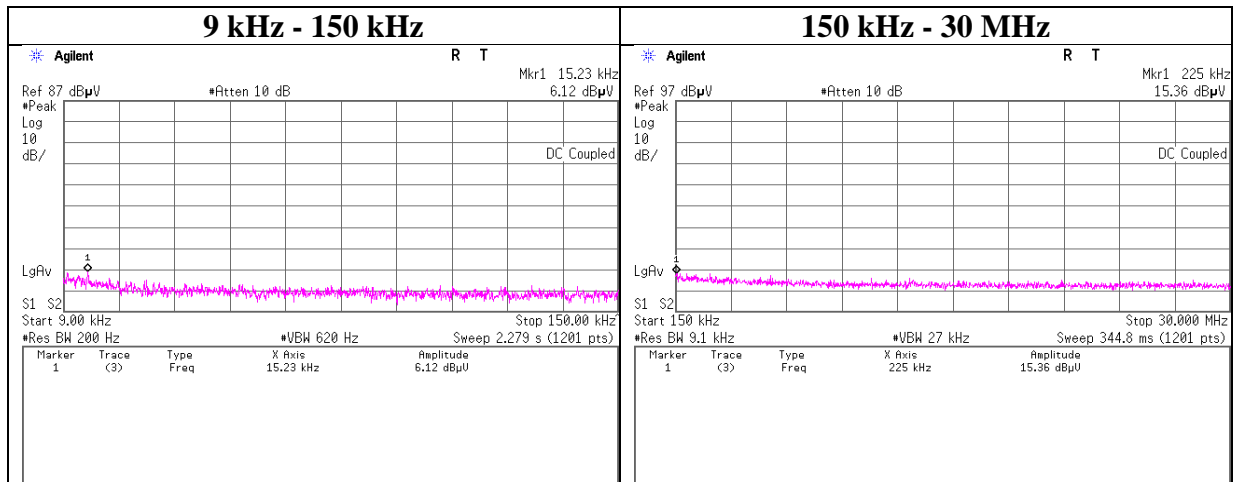

## Conducted Spurious Emission

Test place	Ise EMC Lab. No.11 Measurement Room
Report No.	12210965H
Date	March 19, 2018
Temperature / Humidity	24 deg. C / 32 % RH
Engineer	Tomoki Matsui
Mode	Tx, Hopping Off, DH5

### 2441 MHz

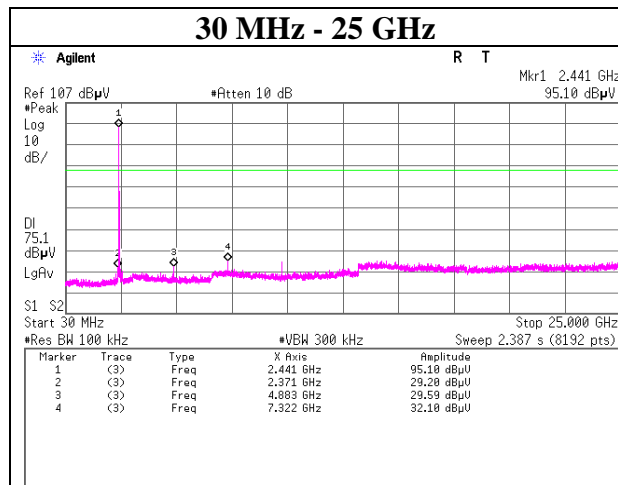
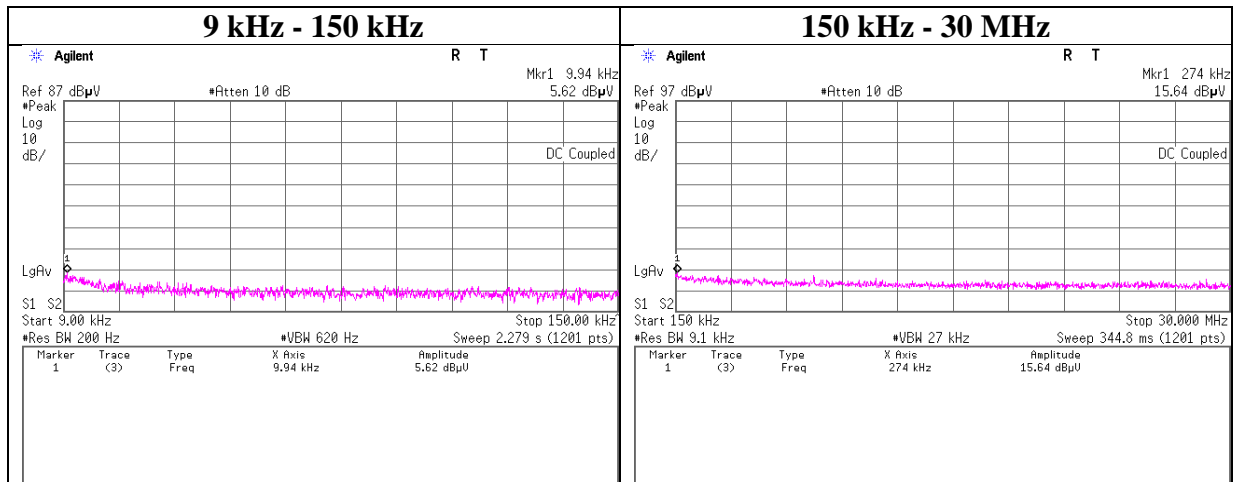

## Conducted Spurious Emission

Test place	Ise EMC Lab. No.11 Measurement Room
Report No.	12210965H
Date	March 19, 2018
Temperature / Humidity	24 deg. C / 32 % RH
Engineer	Tomoki Matsui
Mode	Tx, Hopping Off, DH5

### 2480 MHz

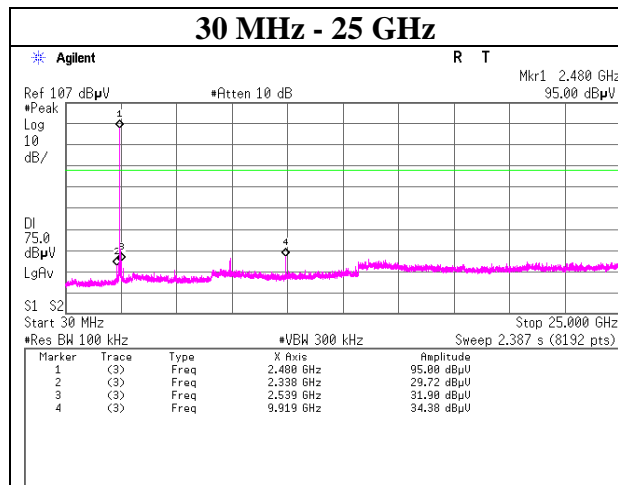
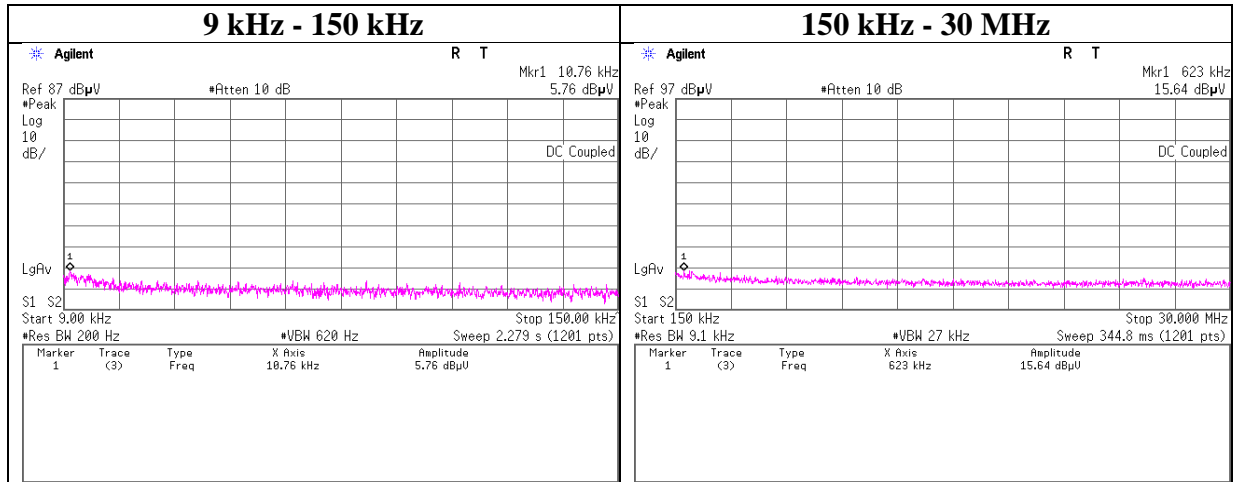

## Conducted Spurious Emission

Test place	Ise EMC Lab. No.11 Measurement Room
Report No.	12210965H
Date	March 19, 2018
Temperature / Humidity	24 deg. C / 32 % RH
Engineer	Tomoki Matsui
Mode	Tx, Hopping Off, 3DH5

### 2402 MHz

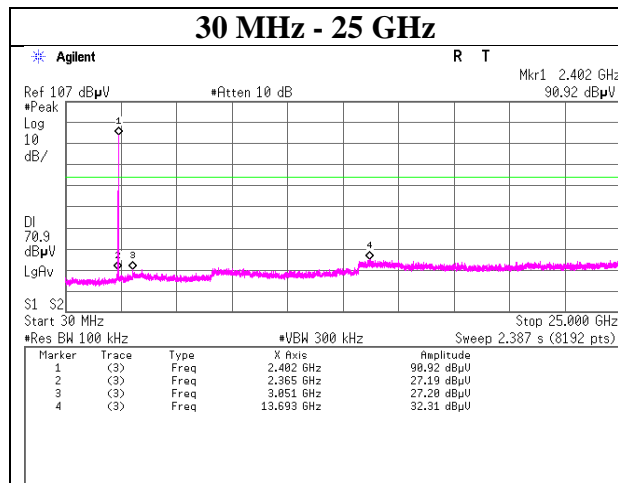
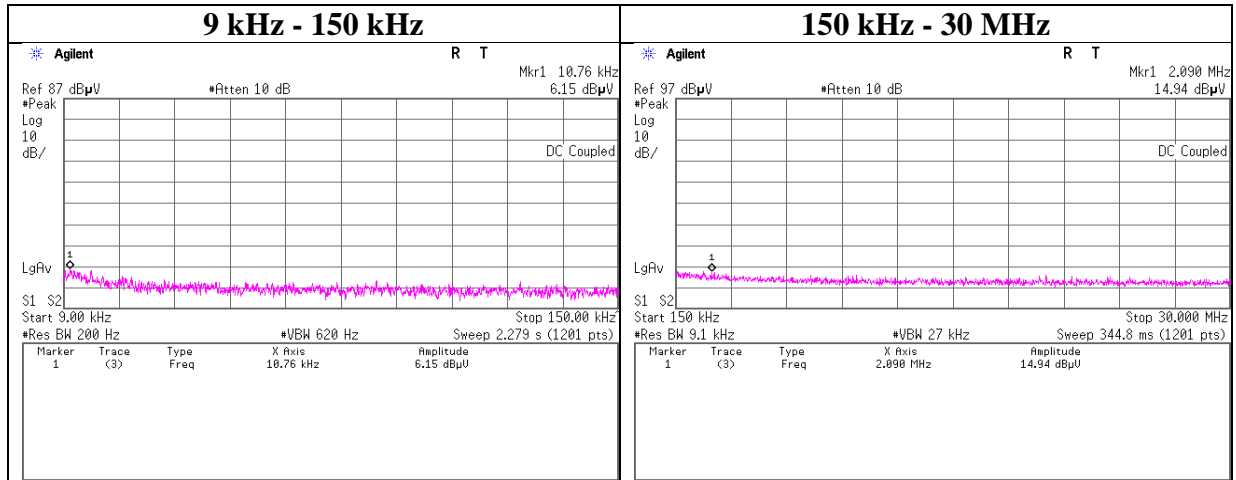

## Conducted Spurious Emission

Test place	Ise EMC Lab. No.11 Measurement Room
Report No.	12210965H
Date	March 19, 2018
Temperature / Humidity	24 deg. C / 32 % RH
Engineer	Tomoki Matsui
Mode	Tx, Hopping Off, 3DH5

### 2441 MHz

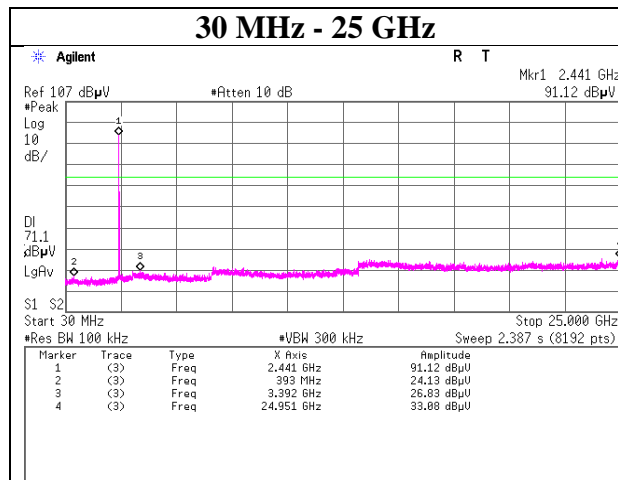
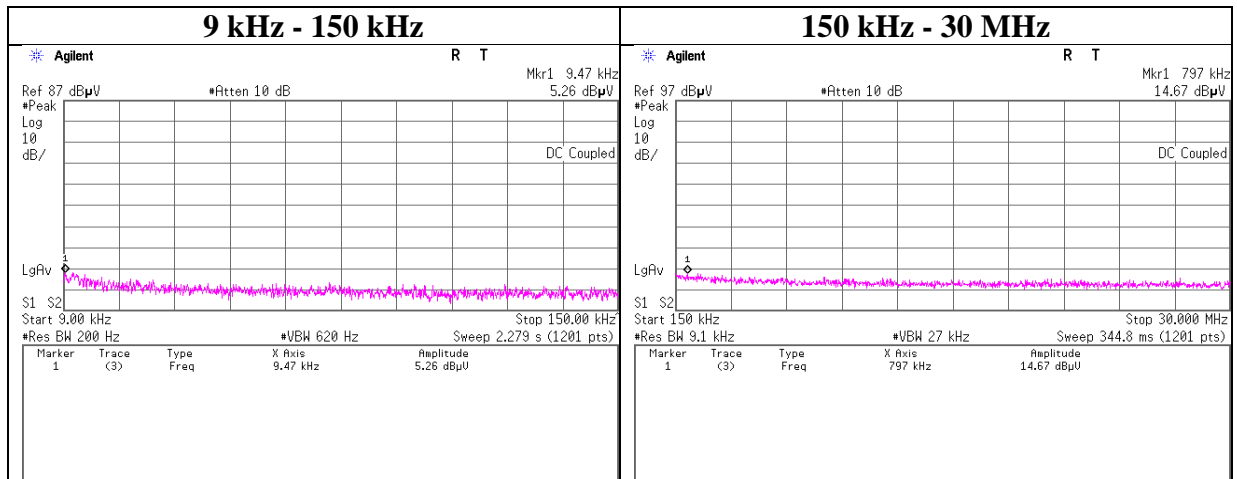



## Conducted Spurious Emission

Test place	Ise EMC Lab. No.11 Measurement Room
Report No.	12210965H
Date	March 19, 2018
Temperature / Humidity	24 deg. C / 32 % RH
Engineer	Tomoki Matsui
Mode	Tx, Hopping Off, 3DH5

### 2480 MHz

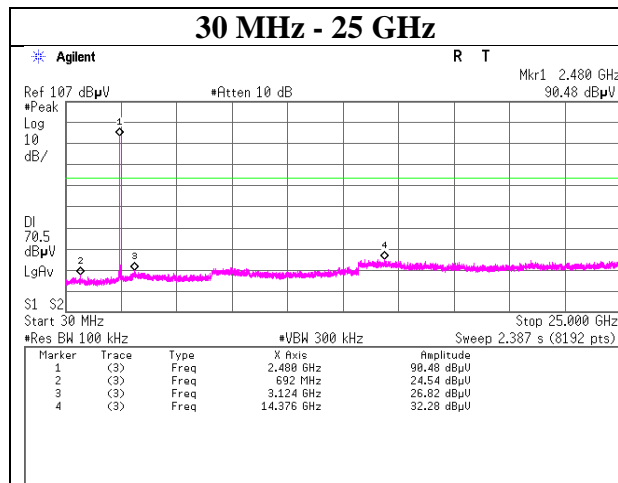
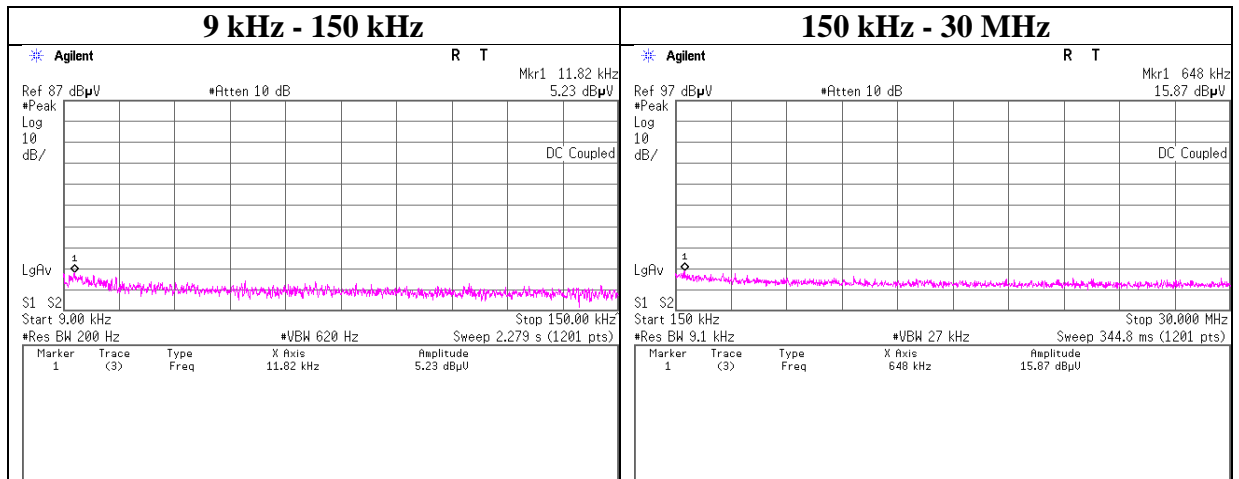

## Conducted Emission Band Edge compliance

Test place	Ise EMC Lab. No.11 Measurement Room
Report No.	12210965H
Date	March 19, 2018
Temperature / Humidity	24 deg. C / 32 % RH
Engineer	Tomoki Matsui
Mode	Tx DH5

### Hopping On

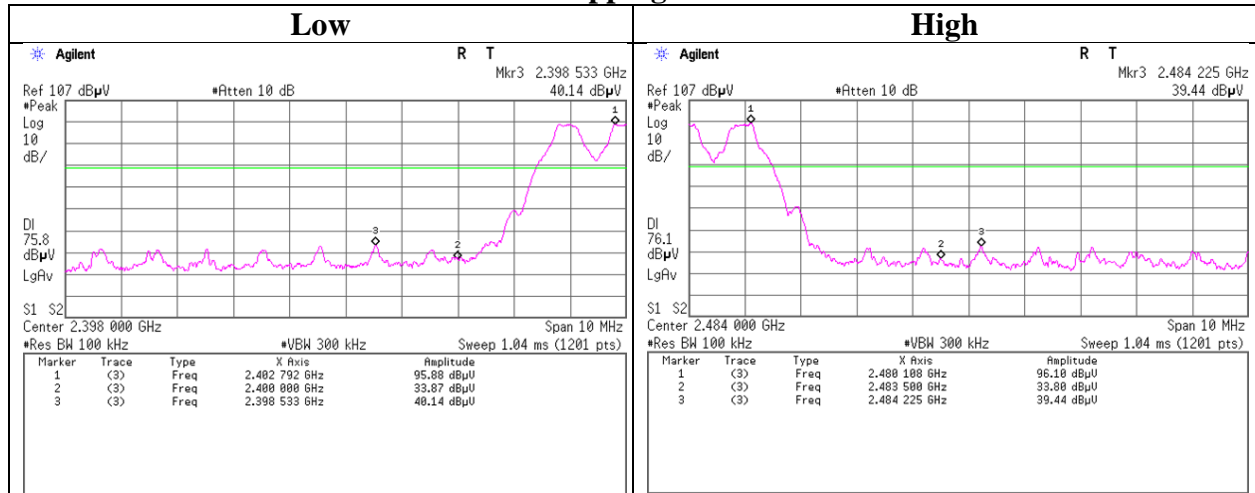

### Hopping Off

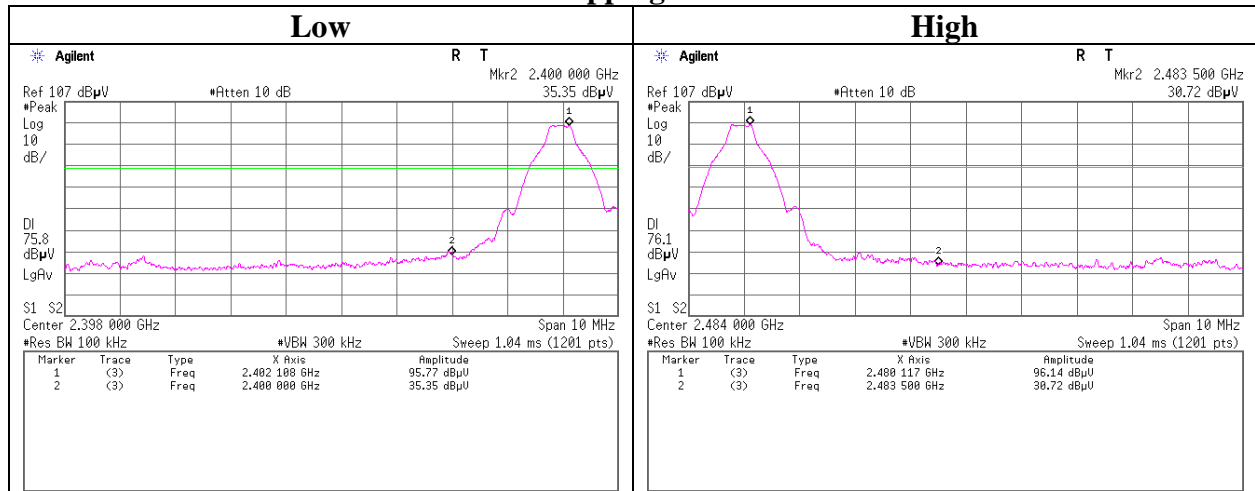

**UL Japan, Inc.**

**Ise EMC Lab.**

4383-326 Asama-cho, Ise-shi, Mie-ken 516-0021 JAPAN

Telephone : +81 596 24 8999

Facsimile : +81 596 24 8124

**Conducted Emission Band Edge compliance**

Test place : Ise EMC Lab. No.11 Measurement Room  
 Report No. : 12210965H  
 Date : March 19, 2018  
 Temperature / Humidity : 24 deg. C / 32 % RH  
 Engineer : Tomoki Matsui  
 Mode : Tx 3DH5

**Hopping On**

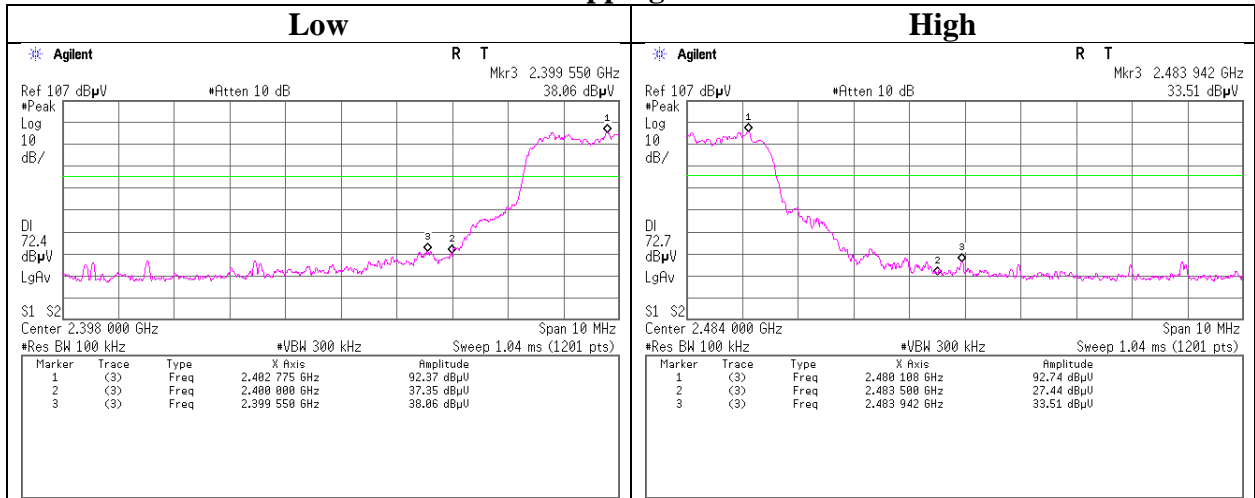

**Hopping Off**

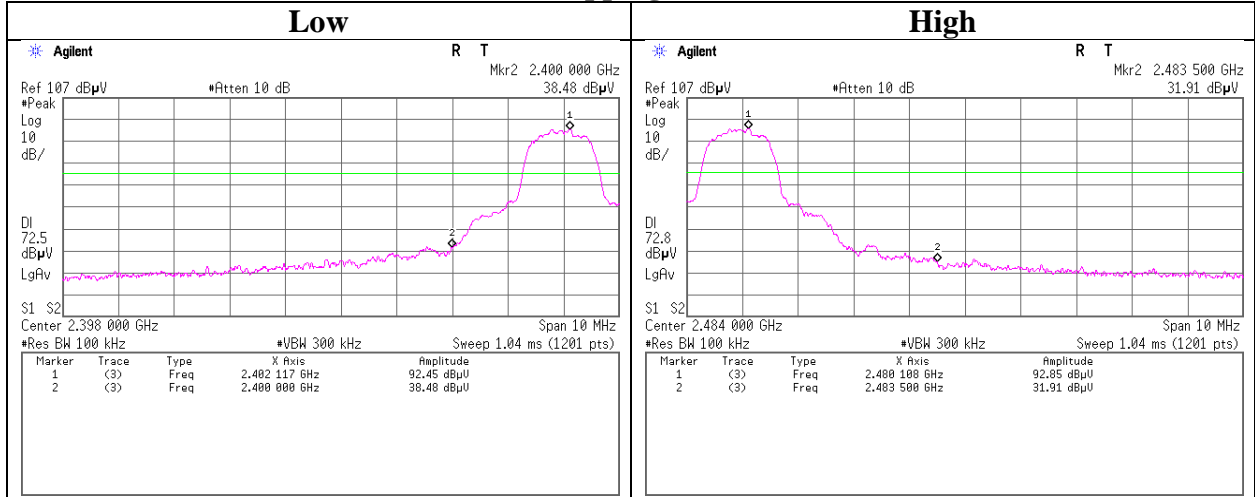

**UL Japan, Inc.**

**Ise EMC Lab.**

4383-326 Asama-cho, Ise-shi, Mie-ken 516-0021 JAPAN

Telephone : +81 596 24 8999

Facsimile : +81 596 24 8124

## **APPENDIX 2: Test instruments**

### **Test Instruments**

Control No.	Instrument	Manufacturer	Model No	Serial No	Test Item	Calibration Date * Interval(month)
MAEC-03	Semi Anechoic Chamber(NSA)	TDK	Semi Anechoic Chamber 3m	DA-10005	RE	2017/10/31 * 12
MOS-13	Thermo-Hygrometer	Custom	CTH-180	1301	RE	2018/01/24 * 12
MJM-16	Measure	KOMELON	KMC-36	-	RE	-
COTS-MEMI	EMI measurement program	TSJ	TEPTO-DV	-	RE	-
MSA-03	Spectrum Analyzer	Agilent	E4448A	MY44020357	RE	2017/11/07 * 12
MHA-20	Horn Antenna 1-18GHz	Schwarzbeck	BBHA9120D	258	RE	2017/05/22 * 12
MCC-167	Microwave Cable	Junkosha	MWX221	1404S374(1m) / 1405S074(5m)	RE	2017/05/29 * 12
MPA-11	MicroWave System Amplifier	Agilent	83017A	MY39500779	RE	2018/03/13 * 12
MHA-16	Horn Antenna 15-40GHz	Schwarzbeck	BBHA9170	BBHA9170306	RE	2017/05/14 * 12
MMM-08	DIGITAL HiTESTER	Hioki	3805	051201197	RE	2018/01/09 * 12
MHF-25	High Pass Filter 3.5-18.0GHz	UL Japan	HPF SELECTOR	001	RE	2017/09/22 * 12
MTR-08	Test Receiver	Rohde & Schwarz	ESCI	100767	RE	2017/08/22 * 12
MBA-03	Biconical Antenna	Schwarzbeck	BBA9106	1915	RE	2017/10/02 * 12
MLA-22	Logperiodic Antenna(200-1000MHz)	Schwarzbeck	VUSLP9111B	911B-191	RE	2018/01/30 * 12
MCC-51	Coaxial cable	UL Japan	-	-	RE	2017/07/12 * 12
MAT-98	Attenuator	KEYSIGHT	8491A	MY52462349	RE	2017/12/14 * 12
MPA-13	Pre Amplifier	SONOMA INSTRUMENT	310	260834	RE	2018/02/27 * 12
MSA-14	Spectrum Analyzer	Agilent	E4440A	MY48250080	AT	2017/10/18 * 12
MPM-09	Power Meter	Anritsu	ML2495A	6K00003348	AT	2017/10/13 * 12
MPSE-12	Power sensor	Anritsu	MA2411B	011598	AT	2017/10/13 * 12
MCC-66	Microwave Cable 1G-40GHz	Suhner	SUCOFLEX102	28636/2	AT	2017/04/04 * 12
MAT-25	Attenuator(10dB)(above1 GHz)	Agilent	8493C	71642	AT	2017/06/12 * 12
MOS-19	Thermo-Hygrometer	Custom	CTH-201	0001	AT	2017/12/21 * 12

**The expiration date of the calibration is the end of the expired month.**

**All equipment is calibrated with valid calibrations. Each measurement data is traceable to the national or international standards.**

**As for some calibrations performed after the tested dates, those test equipment have been controlled by means of an unbroken chains of calibrations.**

**Test item: RE: Radiated Emission test  
AT: Antenna Terminal Conducted test**

**UL Japan, Inc.**

**Ise EMC Lab.**

4383-326 Asama-cho, Ise-shi, Mie-ken 516-0021 JAPAN

Telephone : +81 596 24 8999

Facsimile : +81 596 24 8124