



Deutsche  
Akkreditierungsstelle  
D-PL-21375-01-02  
D-PL-21375-01-03



BNetzA-CAB-21/21-21

# Partial Test Report

**Test report no.:** 23038521-32374-0

**Date of issue:** 2023-07-18

**Test result:** The test item - **passed** - and complies with the listed standards.

## Applicant

Mitsubishi Electric Corporation Sanda Works

## Manufacturer

Mitsubishi Electric Corporation

## Test Item

R1LOW-R

## RF-Spectrum Testing

according to:

### FCC 47 CFR Part 15

Radio Frequency Devices (Subpart E)

### RSS-247 Issue 2

Digital Transmission Systems (DTSs), Frequency Hopping Systems (FHSs) and Licence-Exempt Local Area Network (LE-LAN) Devices

### RSS-Gen Issue 5

General Requirements for Compliance of Radio Apparatus

Tested by  
(name, function, signature)

*Piotr Sardyko*  
Lab Manager

  
signature

Approved by  
(name, function, signature)

*Andreas Bender*  
Deputy Managing Director

  
signature

<b>Applicant and Test item details</b>	
<b>Applicant</b>	Mitsubishi Electric Corporation Sanda Works 2-3-33, Miwa, Sanda-City, Hyogo 669-1513 Japan DESIGN-A SECTION, MULTIMEDIA DESIGN DEPT. Fon: +81 79 559 3505 E-Mail: Kuriyama.Koichi@bc.MitsubishiElectric.co.jp
<b>Manufacturer</b>	Mitsubishi Electric Corporation 2-3-33, Miwa, Sanda-City, Hyogo 669-1513 Japan DESIGN-A SECTION, MULTIMEDIA DESIGN DEPT. Fon: +81 79 559 3505 E-Mail: Kuriyama.Koichi@bc.MitsubishiElectric.co.jp
<b>Test item description</b>	Automotive Display Audio
<b>Model/Type reference</b>	R1LOW-R
<b>Standard specific information</b>	
<b>FCC ID</b>	UJH-R1LOW-R
<b>IC</b>	662K-R1LOWR
<b>PMN</b>	R1LOW-R
<b>HVIN variant ID#79</b>	79
<b>HVIN variant ID#80</b>	80
<b>FVIN</b>	N/A
<b>HMN</b>	N/A
<b>Frequency</b>	UNII bands 5150 MHz to 5850 MHz)
<b>Technology</b>	Type of radio transmission: OFDM Type of modulation: BPSK, QPSK, 16QAM, 64QAM, 256QAM
<b>Number of channels</b>	25 (20 MHz), 12 (40 MHz), 6 (80 MHz)
<b>Antenna</b>	Sheet metal antenna
<b>Power supply</b>	9 – 16.5V DC Battery
<b>Temperature range</b>	-40 °C to +75 °C

### Disclaimer and Notes

The content of this report relates to the mentioned test sample(s) only.  
Without a written permit of IBL-Lab GmbH, this test report shall not be reproduced, except in full.

The last valid version is available at TAMSys®.

Copyright ©: All rights reserved by IBL-Lab GmbH

Within this test report, a  point /  comma is used as a decimal separator.  
If otherwise, a detailed note is added adjoined to its use.

IBL-Lab GmbH does not take test samples. The sample used for testing is provided by the applicant.

Decision rule:

Decision rule based on simple acceptance without guard bands, binary statement, based on mutually agreed uncertainty tolerances with expansion factor k=2 according to ILAC-G8:09/2019

# 1 TABLE OF CONTENTS

1	TABLE OF CONTENTS .....	3
2	GENERAL INFORMATION .....	4
2.1	Administrative details .....	4
2.2	Possible test case verdicts .....	4
2.3	Observations .....	5
2.4	Opinions and Interpretations .....	5
2.5	Revision History .....	5
2.6	Further documents .....	5
3	ENVIRONMENTAL & TEST CONDITIONS .....	6
3.1	Environmental conditions .....	6
3.2	Normal and extreme test conditions .....	6
4	TEST STANDARDS AND REFERENCES .....	6
5	EQUIPMENT UNDER TEST (EUT) .....	7
5.1	Product Description .....	7
5.2	Test Item Description .....	7
5.3	Technical Data of Equipment .....	8
5.4	Additional Information .....	10
5.5	Test modes .....	11
6	SUMMARY OF TEST RESULTS .....	12
7	TEST RESULTS .....	13
7.1	Antenna Gain, radiated peak power .....	13
7.2	Band Edge Compliance (BEC), radiated .....	15
7.3	Radiated Spurious Emissions (RSE) .....	18
8	TEST SETUP DESCRIPTION .....	20
8.1	Semi Anechoic Chamber with Ground Plane .....	20
8.2	Fully Anechoic Chamber .....	22
8.3	Radiated measurements > 18 GHz .....	24
8.4	Conducted measurements WLAN test system R&S TS 8997 .....	25
9	MEASUREMENT UNCERTAINTIES .....	26

## 2 GENERAL INFORMATION

### 2.1 Administrative details

Testing laboratory	<b>IBL-Lab GmbH</b> Heinrich-Hertz-Allee 7 66386 Sankt Ingbert / Germany Fon: +49 6894 38938-0 Fax: +49 6894 38938-99 URL: <a href="http://www.ib-lenhardt.de">www.ib-lenhardt.de</a> E-Mail: <a href="mailto:info@ib-lenhardt.de">info@ib-lenhardt.de</a>
Accreditation	The testing laboratory is accredited by Deutsche Akkreditierungsstelle GmbH (DAkkS) in compliance with DIN EN ISO/IEC 17025:2018.  Scope of testing and registration number: <ul style="list-style-type: none"> <li>• Electronics, EMC, Radio <span style="float: right;"><a href="#">D-PL-21375-01-01</a></span></li> <li>• Electromagnetic Compatibility and Telecommunication (FCC requirements) Testing Laboratory Designation Number <span style="float: right;"><a href="#">D-PL-21375-01-02</a> DE0024</span></li> <li>• Telecommunication (TC) and Electromagnetic Compatibility (EMC) for Canadian Standards <span style="float: right;"><a href="#">D-PL-21375-01-03</a> 27156 Testing Laboratory CAB Identifier DE0020</span></li> </ul> Website DAkkS: <a href="https://www.dakks.de/">https://www.dakks.de/</a>  The Deutsche Akkreditierungsstelle GmbH (DAkkS) is also a signatory to the <a href="#">ILAC Mutual Recognition Arrangement</a>
Testing location	<b>IBL-Lab GmbH</b> Heinrich-Hertz-Allee 7 66386 St. Ingbert / Germany
Date of receipt of test samples	2023-06-28
Start – End of tests	2023-06-28 – 2023-07-10

### 2.2 Possible test case verdicts

Test sample meets the requirements	P (PASS) – the measured value is below the acceptance limit, AL = TL
Test sample does not meet the requirements	F (FAIL) – the measured value is above the acceptance limit, AL = TL
Test case does not apply to the test sample	N/A (Not applicable)
Test case not performed	N/P (Not performed)

## 2.3 Observations

No additional observations other than the reported observations within this test report have been made.

## 2.4 Opinions and Interpretations

No appropriate opinions or interpretations according ISO/IEC 17025:2017 clause 7.8.7 are within this test report.

## 2.5 Revision History

-0 Initial Version

## 2.6 Further documents

List of further applicable documents belonging to the present test report:

- TR-23038521-32374-0\_AnnexA (test results EUT).pdf
- TR-23038521-32374-0\_AnnexB (external photos EUT).pdf
- TR-23038521-32374-0\_AnnexC (internal photos EUT).pdf
- TR-23038521-32374-0\_AnnexD (test setup FCC - IC).pdf
- TR-21065784-21223-x.pdf (latest available version)
- TR-21065784-21223-x\_AnnexA (test results EUT).pdf
- TR-21065784-21223-x\_AnnexB (external photos EUT).pdf
- TR-21065784-21223-x\_AnnexC (internal photos EUT).pdf
- TR-21065784-21223-x\_AnnexD (test setup FCC - IC).pdf

### 3 ENVIRONMENTAL & TEST CONDITIONS

#### 3.1 Environmental conditions

Temperature	20°C ± 5°C
Relative humidity	25-75 % r.H.
Barometric Pressure	860-1060 mbar
Power supply	230 V / 50 Hz

#### 3.2 Normal and extreme test conditions

	minimum	nominal	maximum
Temperature	-/-	+25 °C	-/-
Relative humidity	-/-	50 % r.h.	-/-
Power supply	-/-	12.6 V DC	-/-

### 4 TEST STANDARDS AND REFERENCES

Test standard (accredited)	Description
FCC 47 CFR Part 15	Radio Frequency Devices (Subpart E)
RSS-247 Issue 2	Digital Transmission Systems (DTSs), Frequency Hopping Systems (FHSs) and Licence-Exempt Local Area Network (LE-LAN) Devices
RSS-Gen Issue 5	General Requirements for Compliance of Radio Apparatus

Test standard (not accredited)	Description
none	---

Reference	Description
ANSI C63.4-2014	American National Standard for Methods of Measurement of Radio-Noise Emissions from Low-Voltage Electrical and Electronic Equipment in the Range of 9 kHz to 40 GHz
ANSI C63.10-2013	American National Standard of Procedures for Compliance Testing of Unlicensed Wireless Devices
789033 D02 General U-NII Test Procedures New Rules v02r01	Guidelines for Compliance Testing of Unlicensed National Information Infrastructure (U-NII) Devices Part 15, Subpart E
905462 D02 UNII DFS Compliance Procedures New Rules v02	Compliance Measurement Procedures for Unlicensed-National Information Infrastructure Devices Operating in the 5250-5350 MHz and 5470-5725 MHz Bands Incorporating Dynamic Frequency Selection

## 5 EQUIPMENT UNDER TEST (EUT)

### 5.1 Product Description

Automotive Display Audio

\*: as declared by applicant

### 5.2 Test Item Description

<b>Model name*</b>	R1LOW-R
<b>EUT status*</b>	25MY PV
<b>Model variants*</b>	ID#79: mechanical variant 8F electrical variant 16 ID#80: mechanical variant 8F electrical variant 26
<b>Serial number of EUT test samples*</b>	ID#79: radiated EUT: R0091 conducted EUT: - ID#80: radiated EUT: R0047 conducted EUT: -
<b>PCB identifier*</b>	N211J71621
<b>Hardware status*</b>	NR-0C-R-25MY-PV
<b>Software status*</b>	Android 10

\*: as declared by applicant; please see Annex B and C to current TR for EUT photographs.

<b>5.3 Technical Data of Equipment</b>	
<b>Operational frequency band*</b>	UNII bands 5150 MHz to 5850 MHz)
<b>Transmitter*</b>	Chip QCA6574AU with 48 MHz TCXO (Module UGKZ5A3006A)
<b>Technology*</b>	802.11 a/n/ac, OFDM
<b>Modulation type*</b>	802.11 a/n: BPSK, QPSK, 16QAM, 64QAM 802.11 ac: BPSK, QPSK, 16QAM, 64QAM, 256 QAM
<b>Data rate*</b>	802.11 a: 6 Mbps – 54 Mbps 802.11 n: 6.5 Mbps – 300 Mbps 802.11 ac: 6.5 Mbps – 866.7 Mbps
<b>Number of channels*</b>	25 (20 MHz bandwidth) 12 (40 MHz bandwidth) 6 (80 MHz bandwidth)
<b>Channel bandwidth*</b>	20/40/80 MHz
<b>Channel spacing*</b>	20/40/80 MHz
<b>Guard Interval*</b>	802.11n, 802.11ac: GI=800 ns, GI=400 ns
<b>Antenna*</b> <b>Part name Antenna 0</b> <b>Part name Antenna 1</b>	Sheet metal antenna, 2342059-2 2342059-1
<b>Antenna gain*</b>	Antenna 0: -2.29 dBi, Antenna 1: -2.81 dBi
<b>Number of Spatial Streams*</b>	NSS=1, NSS=2
<b>Rated RF Output Power*</b>	Maximum rated RF output power is maximum measured RF output power value (see section 7.1) plus 2dB: 802.11 a: 7.7 dBm 802.11 n: 6.7 – 7.1 dBm (depending on channel bandwidth) 802.11 ac: 6.1 – 7.0 dBm (depending on channel bandwidth)
<b>Transmit Power Control*</b>	yes (follows attenuation – power constraint IE - from access point)
<b>DFS capability*</b>	yes
<b>DFS mode*</b>	Secondary (Slave) without radar detection
<b>Power supply*</b>	9 – 16.5V DC Battery, $V_{nom}=12.6$ V
<b>Temperature range*</b>	-40 °C to +75 °C, $T_{nom}=+25$ °C

\*: as declared by applicant



Channels with **20 MHz** channel bandwidth:

U-NII-1 & U-NII-2A (5150 MHz to 5250 MHz & 5250 MHz to 5350 MHz) channel number & center frequency								
channel	36	40	44	48	52	56	60	64
f <sub>c</sub> / MHz	5180	5200	5220	5240	5260	5280	5300	5320

U-NII-2C (5470 MHz to 5725 MHz) channel number & center frequency												
channel	100	104	108	112	116	120	124	128	132	136	140	144
f <sub>c</sub> / MHz	5500	5520	5540	5560	5580	5600	5620	5640	5660	5680	5700	5720

U-NII-3 (5725 MHz to 5850 MHz) channel number & center frequency					
channel	149	153	157	161	165
f <sub>c</sub> / MHz	5745	5765	5785	5805	5825

Channels with **40 MHz** channel bandwidth:

U-NII-1 & U-NII-2A (5150 MHz to 5250 MHz & 5250 MHz to 5350 MHz) channel number & center frequency				
channel	38	46	54	62
f <sub>c</sub> / MHz	5190	5230	5270	5310

U-NII-2C (5470 MHz to 5725 MHz) channel number & center frequency						
channel	102	110	118	126	134	142
f <sub>c</sub> / MHz	5510	5550	5590	5630	5670	5710

U-NII-3 (5725 MHz to 5850 MHz) channel number & center frequency		
channel	151	159
f <sub>c</sub> / MHz	5755	5795

Channels with **80 MHz** channel bandwidth:

U-NII-1 & U-NII-2A (5150 MHz to 5250 MHz & 5250 MHz to 5350 MHz) channel number & center frequency		
channel	42	58
f <sub>c</sub> / MHz	5210	5290

U-NII-2C (5470 MHz to 5725 MHz) channel number & center frequency			
channel	106	122	138
f <sub>c</sub> / MHz	5530	5610	5690

U-NII-3 (5725 MHz to 5850 MHz) channel number & center frequency	
channel	155
f <sub>c</sub> / MHz	5775

<b>5.4 Additional Information</b>	
<b>Model variant differences*</b>	<ul style="list-style-type: none"> <li>• R1LOW-R DV model with integrated sheet metal antenna and associated display, PCB ID NJ00193611</li> <li>• R1LOW-R 25MY PV model with integrated sheet metal antenna and associated display, PCB ID N211J71621</li> </ul> <p><b>Applicant declares that transmitter modul with chip and sheet metal antenna are identical in R1LOW-R DV model (see IBL-Lab test report TR-21065784-21223) and R1LOW-R 25MY PV model.</b></p> <p><b>Mechanical variants of R1LOW-R 25MY PV model listed in section 5.2 refer to different dimensions of associated display.</b></p> <p><b>Electrical variants of R1LOW-R 25MY PV model listed in section 5.2 refer to different memory chipsets and multimedia chipsets and interfaces.</b></p> <p>Test results of R1LOW-R DV model are used for following test cases (see IBL-Lab test report TR-21065784-21223):</p> <ul style="list-style-type: none"> <li>• 6 dB emission bandwidth</li> <li>• 26 dB emission bandwidth</li> <li>• Occupied Channel Bandwidth (99%)</li> <li>• Peak power spectral density (PSD)</li> <li>• Band edge compliance (BEC), conducted</li> <li>• Conducted spurious emissions (CSE)</li> <li>• Dynamic Frequency Selection (DFS)</li> <li>• RF output power (conducted peak power)</li> </ul> <p>Radiated R1LOW-R 25MY PV test samples of all mechanical model variants are used for following test cases:</p> <ul style="list-style-type: none"> <li>• Antenna gain, radiated peak power</li> </ul> <p>Radiated R1LOW-R 25MY PV test samples of all model variants are used for following test cases:</p> <ul style="list-style-type: none"> <li>• Band edge compliance (BEC), radiated</li> <li>• Radiated spurious emissions (RSE) – worst case from R1LOW-R DV tests (see IBL-Lab test report TR-21065784-21223)</li> </ul>
<b>Ancillaries tested with</b>	None
<b>Additional equipment used for testing</b>	Notebook with test tool

\*: as declared by applicant

<b>5.5 Test modes</b>	
<b>Mode 1, a-mode</b>	20 MHz bandwidth, Modulation type: BPSK 6.0 Mbps*
<b>Mode 2, n-HT20 mode</b>	20 MHz bandwidth, Modulation type: BPSK 13.0 Mbps, NSS=2*
<b>Mode 3, n-HT40 mode</b>	40 MHz bandwidth, Modulation type: BPSK 27.0 Mbps, NSS=2*
<b>Mode 4, ac-HT20-mode</b>	20 MHz bandwidth, Modulation type: BPSK, 13.0 Mbps, NSS=2*
<b>Mode 5, ac-HT40-mode</b>	40 MHz bandwidth, Modulation type: BPSK, 27.0 Mbps, NSS=2*
<b>Mode 6, ac-HT80-mode</b>	80 MHz bandwidth, Modulation type: BPSK, 58.5 Mbps, NSS=2*
<b>Channel</b>	Channels used for testing are marked in bold in 20 MHz, 40 MHz, 80 MHz channel lists (see section 5.3)
<b>Antennas and transmit operating mode</b>	Equipment with 2 antennas/transmit chains are used simultaneously but without beamforming
<b>Worst case configuration with respect to RF output power**</b>	<p>Conducted RF output power of R1LOW-R DV model has been measured for following modulation types, antenna gains and data rates for following channels (respective channel frequencies and bandwidth see channel lists in section 5.3):</p> <ul style="list-style-type: none"> <li>- 802.11a, all modulation types and data rates, NSS=2 (antenna 0 + 1) for <ul style="list-style-type: none"> <li>o 20 MHz channel 44, 60, 120, 157</li> </ul> </li> <li>- 802.11n, all modulation types and data rates, NSS=2 (antenna 0 + 1) for <ul style="list-style-type: none"> <li>o 20 MHz channel 44, 60, 120, 157 and</li> <li>o 40 MHz channel 46, 62, 126, 159</li> </ul> </li> <li>- 802.11ac, all modulation types and data rates, NSS=2 (antenna 0 + 1) for <ul style="list-style-type: none"> <li>o 20 MHz channel 44, 60, 120, 157 and</li> <li>o 40 MHz channel 46, 62, 126, 159 and</li> <li>o 80 MHz channel 42, 58, 122, 155</li> </ul> </li> <li>- 802.11a, BPSK, NSS=2, antenna 0 + 1 for channel frequencies marked in bold in 20 MHz channel list (see section 5.3)</li> <li>- 802.11n, BPSK, NSS=2, antenna 0 + 1 for channel frequencies marked in bold in 20, 40 MHz channel list (see section 5.3)</li> <li>- 802.11ac, BPSK, NSS=2, antenna 0 + 1 for channel frequencies marked in bold in 20, 40, 80 MHz channel list (see section 5.3)</li> </ul> <p>* From conducted RF output measurements of R1LOW-R DV model test modes have been selected based on measured maximum conducted output power</p> <ul style="list-style-type: none"> <li>• Test mode 1, 2, 3, 4, 5, 6 for RF output power (conducted peak power)</li> <li>• Test mode 1 for mean E.I.R.P.</li> <li>• Test mode 1, 3, 6 for Band edge compliance (BEC), radiated</li> <li>• Test mode 1 for Radiated spurious emissions (RSE)</li> </ul>

\*\* Worst case analysis according ANSI C63.10-2013 ch. 5.6.2.2 has been performed based on conducted RF output power measurements. As a result, maximum output power is achieved when antenna port 0 and antenna port 1 are used for simultaneous transmission (antenna 0 + 1) when compared to respective usage of antenna port 0 or antenna port 1 alone:

- for 802.11a, n and ac WLAN technologies test tool provided by applicant allowed separate **and** simultaneous transmission using antenna port 0 and antenna port 1.

## 6 SUMMARY OF TEST RESULTS

### Test specification

FCC 47 CFR Part 15  
RSS-247 Issue 2 / RSS-Gen Issue 5

Clause	Requirement / Test Case	Guideline - Remark	Verdict
§15.407(e) RSS-247, 6.2.4.1	6 dB emission bandwidth	KDB 789033, section C	- N/P - *)
§15.407(a) RSS-247, 6.2.1.2	26 dB emission bandwidth	KDB 789033, section C	- N/P - *)
RSS Gen, 6.7	Occupied bandwidth (99%)	KDB 789033, section D	- N/P - *)
§15.407(a) RSS-247, 6.2	RF output power (conducted peak power)	KDB 789033, section E	- N/P - *)
§15.407(a) RSS-247, 6.2	Antenna gain (calculated)	-/-	- PASS -
§15.407(a) RSS-247, 6.2	Peak power spectral density (PSD)	KDB 789033, section F	- N/P - *)
§15.407(b) RSS-247, 6.2	Band edge compliance (BEC), conducted	KDB 789033, section G	- N/P - *)
§15.407(b) RSS-247, 6.2	Band edge compliance (BEC), radiated	KDB 789033, section G	- PASS -
§15.407(b) RSS-247, 6.2	Conducted spurious emissions (CSE)	KDB 789033, section G	- N/P - *)
§15.407(b) / §15.209 RSS-247, 6.2 / RSS-Gen, 8.9	Radiated spurious emissions (RSE)	KDB 789033, section G	- PASS -
§15.407(h)(1) RSS-247, 6.2	Transmit Power Control	A TPC mechanism is not required for systems with an e.i.r.p. of less than 500 mW	- N/A -
§15.407(h)(2) RSS-247, 6.3	Dynamic Frequency Selection (DFS) - channel availability check - channel move time - non occupancy period	KDB 905462	- N/P - *)
§15.207 RSS-Gen, 8.8	AC conducted emissions	EUT is battery powered	- N/A -

\*) see IBL-Lab test report TR-21065784-21223

### Comments and observations

Following pages show requirements and references of FCC Part 15.407, ANSI C63.10, KDB 789033 and KDB 905462 only. Same tests are also applicable and valid for RSS-247, with clauses given in table above.

## 7 TEST RESULTS

### 7.1 Antenna Gain, radiated peak power

#### Applicability

This requirement applies to unlicensed National Information Infrastructure (U-NII) devices operating in the 5.15–5.35 GHz, 5.47–5.725 GHz and 5.725–5.85 GHz bands

#### Description

The antenna gain is defined as the difference between radiated peak power (Peak EIRP) subtracted by the conducted peak power of the module, given in dBi.

#### Limit

§15.407 (a), RSS-247 section 6.2:

If transmitting antennas of directional gain greater than 6 dBi are used, both the maximum conducted output power and the maximum power spectral density shall be reduced by the amount in dB that the directional gain of the antenna exceeds 6 dBi

**Test setup:** 8.2 with radiated test sample (see section 5.2), test setup photographs see Annex D to current Report

#### Test Results: 20 MHz Bandwidth, a-mode

##### Test Results 5.150 – 5.350 GHz

Radiated peak power [dBm]	channel 36	channel 48	channel 52	channel 64	Limit
EUT ID #79, Mode 1	6.52	6.95	4.09	3.06	≤ 36
EUT ID #80, Mode 1	6.77	7.35	7.09	6.03	≤ 36
Antenna gain antenna 0 [dBi]*	-2.29	-2.29	-2.29	-2.29	≤ 6
Antenna gain antenna 1 [dBi]*	-2.81	-2.81	-2.81	-2.81	≤ 6

\* see section 5.3

##### Test Results 5.470 – 5.725 GHz

Radiated peak power [dBm]	channel 100	channel 120	channel 140	channel 144	Limit
EUT ID #79, Mode 1	4.58	5.54	7.1	5.26	≤ 36
EUT ID #80, Mode 1	5.78	6.78	5.96	8.48	≤ 36
Antenna gain antenna 0 [dBi]*	-2.29	-2.29	-2.29	-2.29	≤ 6
Antenna gain antenna 1 [dBi]*	-2.81	-2.81	-2.81	-2.81	≤ 6

\* see section 5.3

##### Test Results 5.725 – 5.850 GHz

Radiated peak power [dBm]	channel 149	channel 157	channel 165	Limit
EUT ID #79, Mode 1	6.5	5.82	4.84	≤ 36

EUT ID #80, Mode 1	8.12	7.99	8.15	≤ 36
Antenna gain antenna 0 [dBi]*	-2.29	-2.29	-2.29	≤ 6
Antenna gain antenna 1 [dBi]*	-2.81	-2.81	-2.81	≤ 6

\* see section 5.3

<b>Comment:</b>	Radiated peak power test was performed as worst case
-----------------	--

<b>Verdict</b>	<b>- PASS -</b>	For plots please see Annex A to current report
----------------	-----------------	--

<b>7.2 Band Edge Compliance (BEC), radiated</b>
<p><b>Applicability</b>          This requirement applies to unlicensed National Information Infrastructure (U-NII) devices operating in the 5.15–5.35 GHz, 5.47–5.725 GHz and 5.725–5.85 GHz bands.</p>
<p><b>Description</b>          KDB 789033 D02 General U-NII Test Procedures New Rules v02r01 II.G.3.d ii          Unwanted band-edge emissions may be measured using either of the special band-edge measurement techniques (the marker-delta or integration methods). Note that the marker-delta method is primarily a radiated measurement technique that requires the 99% occupied bandwidth edge to be within 2 MHz of the authorized band edge, whereas the integration method can be used in either a radiated or conducted measurement without any special requirement with regards to the displacement of the unwanted emission(s) relative to the authorized bandwidth.</p>
<p><b>Limits</b>          §15.407(b)          RSS-247, 6.2          The maximum emissions outside of the frequency bands of operation shall be attenuated in accordance with the following limits:          (1) For transmitters operating in the 5.15–5.25 GHz band: All emissions outside of the 5.15–5.35 GHz band shall not exceed an e.i.r.p. of -27 dBm/MHz.          (2) For transmitters operating in the 5.25–5.35 GHz band: All emissions outside of the 5.15–5.35 GHz band shall not exceed an e.i.r.p. of -27 dBm/MHz.          (3) For transmitters operating in the 5.47–5.725 GHz band: All emissions outside of the 5.47–5.725 GHz band shall not exceed an e.i.r.p. of -27 dBm/MHz.          (4) For transmitters operating in the 5.725–5.85 GHz band:          (i) All emissions shall be limited to a level of -27 dBm/MHz at 75 MHz or more above or below the band edge increasing linearly to 10 dBm/MHz at 25 MHz above or below the band edge, and from 25 MHz above or below the band edge increasing linearly to a level of 15.6 dBm/MHz at 5 MHz above or below the band edge, and from 5 MHz above or below the band edge increasing linearly to a level of 27 dBm/MHz at the band edge.</p>
<p><b>Test procedure</b>          The marker-delta method as described in ANSI C63.10, 6.10.6 or the integration method as described in ANSI C63.10, 11.13.3 can be used to perform measurements of the unwanted emissions level at the band edges.</p>
<p><b>Test setup:</b> 8.2 with radiated sample (see section 5.2)</p>

<b>Test results 20 MHz (antenna 0 + 1)</b>				
<b>EUT ID, testing mode, frequency band</b>	<b>low channel [dBµV/m @3m]</b>	<b>high channel [dBµV/m @3m]</b>	<b>Limit AVG / Peak [dBµV/m @3m]</b>	<b>Verdict</b>
EUT ID#79, Mode 1, U-NII-1 & U-NII-2A	≤ 50 AVG / ≤ 60 PK	≤ 50 AVG / ≤ 60 PK	≤ 54 AVG / ≤ 74 PK	- PASS -
EUT ID#79, Mode 1, U-NII-2C & U-NII-3	≤ 50 AVG / ≤ 60 PK	≤ 50 AVG / ≤ 60 PK	≤ 54 AVG / ≤ 74 PK	- PASS -
EUT ID#80, Mode 1, U-NII-1 & U-NII-2A	≤ 50 AVG / ≤ 60 PK	≤ 50 AVG / ≤ 60 PK	≤ 54 AVG / ≤ 74 PK	- PASS -
EUT ID#80, Mode 1, U-NII-2C & U-NII-3	≤ 50 AVG / ≤ 60 PK	≤ 50 AVG / ≤ 60 PK	≤ 54 AVG / ≤ 74 PK	- PASS -

<b>Test results 40 MHz (antenna 0 + 1)</b>				
<b>EUT ID, testing mode, frequency band</b>	<b>low channel [dBµV/m @3m]</b>	<b>high channel [dBµV/m @3m]</b>	<b>Limit AVG / Peak [dBµV/m @3m]</b>	<b>Verdict</b>
EUT ID#79, Mode 3, U-NII-1 & U-NII-2A	≤ 54 AVG / ≤ 60 PK	≤ 54 AVG / ≤ 60 PK	≤ 54 AVG / ≤ 74 PK	- PASS -
EUT ID#79, Mode 3, U-NII-2C & U-NII-3	≤ 54 AVG / ≤ 60 PK	≤ 54 AVG / ≤ 60 PK	≤ 54 AVG / ≤ 74 PK	- PASS -
EUT ID#80, Mode 3, U-NII-1 & U-NII-2A	≤ 50 AVG / ≤ 60 PK	≤ 50 AVG / ≤ 60 PK	≤ 54 AVG / ≤ 74 PK	- PASS -
EUT ID#80, Mode 3, U-NII-2C & U-NII-3	≤ 50 AVG / ≤ 60 PK	≤ 50 AVG / ≤ 60 PK	≤ 54 AVG / ≤ 74 PK	- PASS -



Test results 80 MHz (antenna 0 + 1)				
EUT ID, testing mode, frequency band	low channel [dBµV/m @3m]	high channel [dBµV/m @3m]	Limit AVG / Peak [dBµV/m @3m]	Verdict
EUT ID#79, Mode 6, U-NII-1 & U-NII-2A	≤ 50 AVG / ≤ 60 PK	≤ 50 AVG / ≤ 60 PK	≤ 54 AVG / ≤ 74 PK	- PASS -
EUT ID#79, Mode 6, U-NII-2C & U-NII-3	≤ 54 AVG / ≤ 70 PK	≤ 54 AVG / ≤ 70 PK	≤ 54 AVG / ≤ 74 PK	- PASS -
EUT ID#80, Mode 6, U-NII-1 & U-NII-2A	≤ 50 AVG / ≤ 60 PK	≤ 50 AVG / ≤ 60 PK	≤ 54 AVG / ≤ 74 PK	- PASS -
EUT ID#80, Mode 6, U-NII-2C & U-NII-3	≤ 50 AVG / ≤ 70 PK	≤ 50 AVG / ≤ 70 PK	≤ 54 AVG / ≤ 74 PK	- PASS -

<b>Comment:</b>	---
-----------------	-----

<b>Verdict</b>	- PASS -	For plots please see Annex A to current report
----------------	----------	--

### 7.3 Radiated Spurious Emissions (RSE)

**Applicability**

This requirement applies to unlicensed National Information Infrastructure (U-NII) devices operating in the 5.15–5.35 GHz, 5.47–5.725 GHz and 5.725–5.85 GHz bands.

**Description**

Spurious emission / unwanted emissions are emission on a frequency or frequencies which are outside the authorized band and the level of which may be reduced without affecting the corresponding transmission of information. Spurious emissions include harmonic emissions, parasitic emissions, intermodulation products and frequency conversion products. Measurements shall be made to detect spurious emissions that may be radiated directly from the cabinet, control circuits, power leads, or intermediate circuit elements under normal conditions of installation and operation.

**Limits**

§15.407(b)

All emissions out- side of the operational frequency band shall not exceed an e.i.r.p. of -27 dBm/MHz. Unwanted emissions below 1 GHz must comply with the general field strength limits set forth in §15.209.

Frequency [MHz]	Field Strength [ $\mu\text{V/m}$ ] / [dB $\mu\text{V/m}$ ]	Measurement distance [m]
0.009 – 0.490	2400/F[kHz]	300
0.490 – 1.705	24000/F[kHz]	30
1.705 – 30.0	30.0 / 29.5	30
30 – 88	100 / 40.0	3
88 – 216	150 / 43.5	3
216 – 960	200 / 46.0	3
960 – 40 000	500 / 54.0	3

**Note:**

Measurements are performed as field strength measurement in dB $\mu\text{V}$ . -27 dBm/MHz limit value corresponds to a limit of 67.9 dB $\mu\text{V}$  measured in a distance of 3.

**Test procedure**

Test according to FCC title 47 part 15 §15.407(b), KDB 789033 D02 General U-NII Test Procedures New Rules v02r01 II.G.4&5 and ANSI C63.10-2013



**Test setup:** 8.1, 8.2, 8.3 with radiated test sample (see section 5.2)

Test results: Test Mode 1, a-mode, 20 MHz bandwidth, Modulation type: BPSK 6.0 Mbps (antenna 0 + 1)					
EUT ID / Channel	Frequency [MHz]	Peak/RMS Detector	Level [dBm]	Limit [dBm]	Verdict
EUT ID#79,80 Ch. 36	see plots	MaxPeak	see plots	see plots	- PASS -
EUT ID#79,80 Ch. 64	see plots	MaxPeak	see plots	see plots	- PASS -
EUT ID#79,80 Ch. 100	see plots	MaxPeak	see plots	see plots	- PASS -
EUT ID#79,80 Ch. 140	see plots	MaxPeak	see plots	see plots	- PASS -
EUT ID#79,80 Ch. 144	see plots	MaxPeak	see plots	see plots	- PASS -
EUT ID#79,80 Ch. 149	see plots	MaxPeak	see plots	see plots	- PASS -
EUT ID#79,80 Ch. 165	see plots	MaxPeak	see plots	see plots	- PASS -

<b>Comment:</b>	Radiated Spurious Emissions (RSE) are performed for - Test mode 1 (20 MHz channel bandwidth)
-----------------	---

<b>Verdict</b>	<b>- PASS -</b>	For plots please see Annex A to current report*
----------------	-----------------	---

\* description of line and marker for all radiated spurious emission (RSE) measurements:

-  positive Peak (Max Hold) trace during pre-scan
-  Max Peak value
-  final Quasi Peak value

## 8 TEST SETUP DESCRIPTION

### 8.1 Semi Anechoic Chamber with Ground Plane

Radiated measurements are performed in vertical and horizontal plane in the frequency range 30 MHz to 1 GHz in a Semi Anechoic Chamber with a metallic ground plane. The EUT is positioned on a non-conductive test table with a height of 0.80 m above the metallic ground plane that covers the whole chamber. The receiving antennas conform to specification ANSI C63.10-2013, American National Standard for Testing Unlicensed Wireless Devices. These antennas can be moved over the height range between 1.0 m and 4.5 m in order to search for maximum field strength emitted from the EUT. The measurement distances between EUT and receiving antennas are indicated in the test setups for the various frequency ranges. For each measurement, the EUT is rotated in all three axes until the maximum field strength is received. The wanted and unwanted emissions are received by a spectrum analyzer where the detector modes and resolution bandwidths over various frequency ranges are set according to requirement ANSI C63.

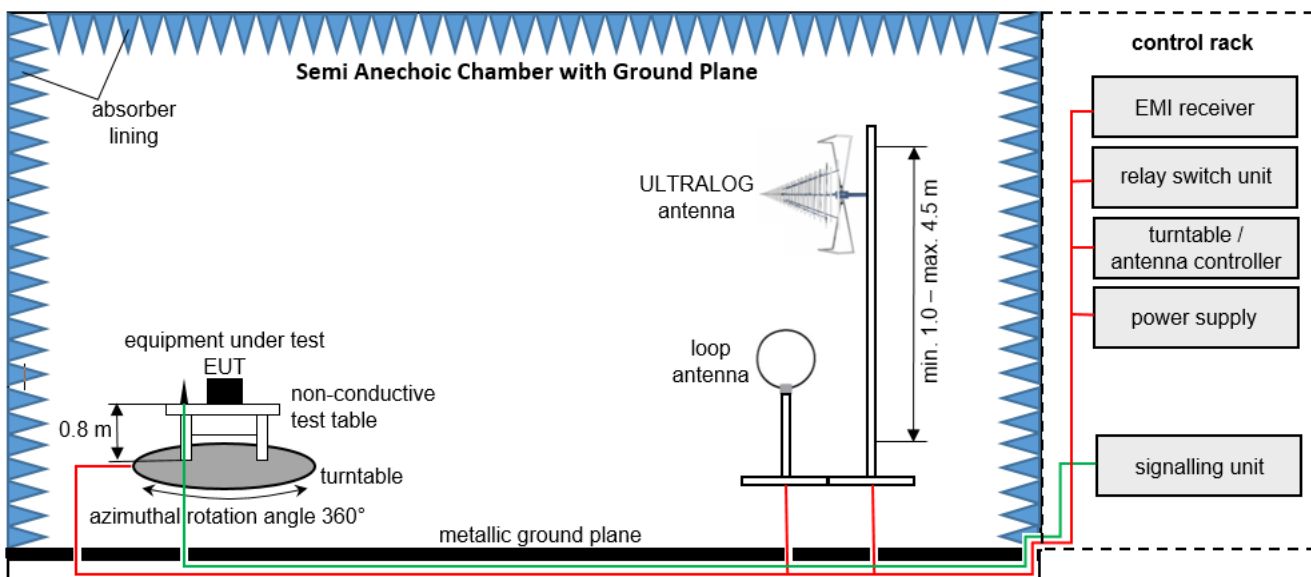

Measurement distance: loop antenna 3 m, ULTRALOG antenna 3 m  
 EMC32 software version: 11.10.00

$$FS = UR + CL + AF$$

(FS-field strength; UR-voltage at the receiver; CL-loss of the cable; AF-antenna factor)

Example calculation:

$$FS [dB\mu V/m] = 12.35 [dB\mu V/m] + 1.90 [dB] + 16.80 [dB/m] = 31.05 [dB\mu V/m] (35.69 \mu V/m)$$

**List of test equipment used:**

No.	Equipment	Manufacturer	Type	Serial No.	INV. No.	Last / Next Calibration
1	Power Supply	Elektro-Automatik GmbH & Co. KG	EA-PSI 9080-40 T	2000230001	LAB000313	N/A
2	Test table	innco systems GmbH	PT1208-080-RH	-	LAB000306	N/A
3	Power Supply	Chroma	61604	616040005416	LAB000285	N/A
4	Positioner	matur GmbH	TD 1.5-10KG		LAB000258	N/A
5	Compressed Air	Implotex	1-850-30	-	LAB000256	N/A
6	EMI Test Receiver	Rohde & Schwarz	ESW26	101517	LAB000363	2023-02-16 → 2024-02-16
7	Semi-Anechoic Chamber (SAC)	Albatross Projects GmbH	SAC 5 (Babylon 5)	20168.PRB	LAB000235	2022-01-31 → 2025-01-31
8	Measurement Software	Rohde & Schwarz	EMC32 V11.00.10		LAB000226	N/A
9	Turntable	matur GmbH	TT2.0-2t	TT2.0-2t/921	LAB000225	N/A
10	Antenna Mast	matur GmbH	CAM4.0-P	CAM4.0-P/316	LAB000224	N/A
11	Antenna Mast	matur GmbH	BAM4.5-P	BAM4.5-P/272	LAB000223	N/A
12	Controller	matur GmbH	FCU 3.0	10082	LAB000222	N/A
13	Power Supply	Elektro-Automatik GmbH & Co. KG	PS 2042-10 B	2878350292	LAB000191	N/A
14	Pre-Amplifier	Schwarzbeck Mess-Elektronik OHG	BBV 9718 C	84	LAB000169	N/A
15	Open Switch and Control Platform	Rohde & Schwarz	OSP200 Base Unit 2HU	101748	LAB000149	N/A
16	Antenna	Rohde & Schwarz	HL562E	102001	LAB000123	2023-06-13 → 2026-06-13
17	Antenna	Rohde & Schwarz	HFH2-Z2E - Active Loop Antenna	100954	LAB000108	2023-04-05 → 2026-04-05

## 8.2 Fully Anechoic Chamber

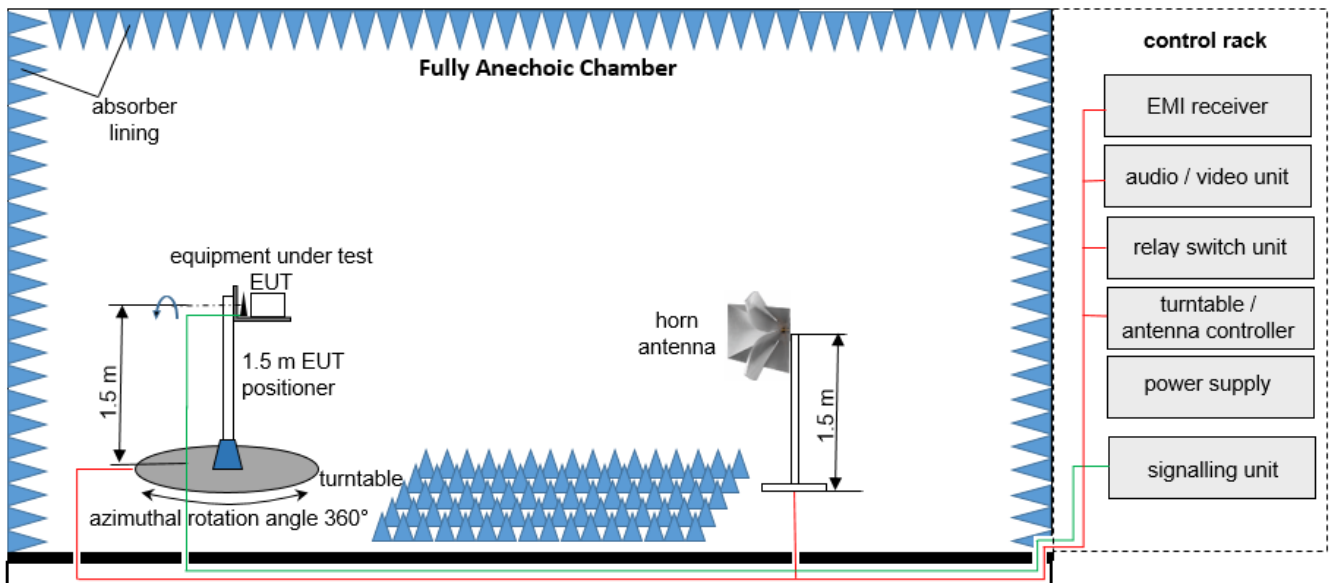

Measurement distance: horn antenna 3 meter

EMC32 software version: 11.10.00

$$FS = UR + CL + AF$$

(FS-field strength; UR-voltage at the receiver; CL-loss of the cable; AF-antenna factor)

Example calculation:

$$FS [dB\mu V/m] = 12.35 [dB\mu V/m] + 1.90 [dB] + 16.80 [dB/m] = 31.05 [dB\mu V/m] (35.69 \mu V/m)$$

$$OP = AV + D - G + CA$$

(OP-radiated output power; AV-analyzer value; D-free field attenuation of measurement distance; G-antenna gain+amplifier gain; CA-loss signal path)

Example calculation:

$$OP [dBm] = -65.0 [dBm] + 50 [dB] - 20 [dBi] + 5 [dB] = -30 [dBm] (1 \mu W)$$

**List of test equipment used:**

No.	Equipment	Manufacturer	Type	Serial No.	INV. No.	Last / Next Calibration
1	Power Supply	Elektro-Automatik GmbH & Co. KG	EA-PSI 9080-40 T	2000230001	LAB000313	N/A
2	Test table	innco systems GmbH	PT1208-080-RH	-	LAB000306	N/A
3	Power Supply	Chroma	61604	616040005416	LAB000285	N/A
4	Positioner	matur GmbH	TD 1.5-10KG	-	LAB000258	N/A
5	Compressed Air	Implotex	1-850-30	-	LAB000256	N/A
6	EMI Test Receiver	Rohde & Schwarz	ESW26	101517	LAB000363	2023-02-16 → 2024-02-16
7	Semi-Anechoic Chamber (SAC)	Albatross Projects GmbH	SAC 5 (Babylon 5)	20168.PRB	LAB000235	2022-01-31 → 2025-01-31
8	Measurement Software	Rohde & Schwarz	EMC32 V11.00.10	-	LAB000226	N/A
9	Turntable	matur GmbH	TT2.0-2t	TT2.0-2t/921	LAB000225	N/A
10	Antenna Mast	matur GmbH	BAM4.5-P	BAM4.5-P/272	LAB000223	N/A
11	Controller	matur GmbH	FCU 3.0	10082	LAB000222	N/A
12	Power Supply	Elektro-Automatik GmbH & Co. KG	PS 2042-10 B	2878350292	LAB000191	N/A
13	Pre-Amplifier	Schwarzbeck Mess-Elektronik OHG	BBV 9718 C	84	LAB000169	N/A
14	Open Switch and Control Platform	Rohde & Schwarz	OSP200 Base Unit 2HU	101748	LAB000149	N/A
15	Antenna	Rohde & Schwarz	HF907	102898	LAB000124	2023-06-13 → 2026-06-13
16	HP-filter	AtlantRF	-	-	LAB000382	N/A

### 8.3 Radiated measurements > 18 GHz

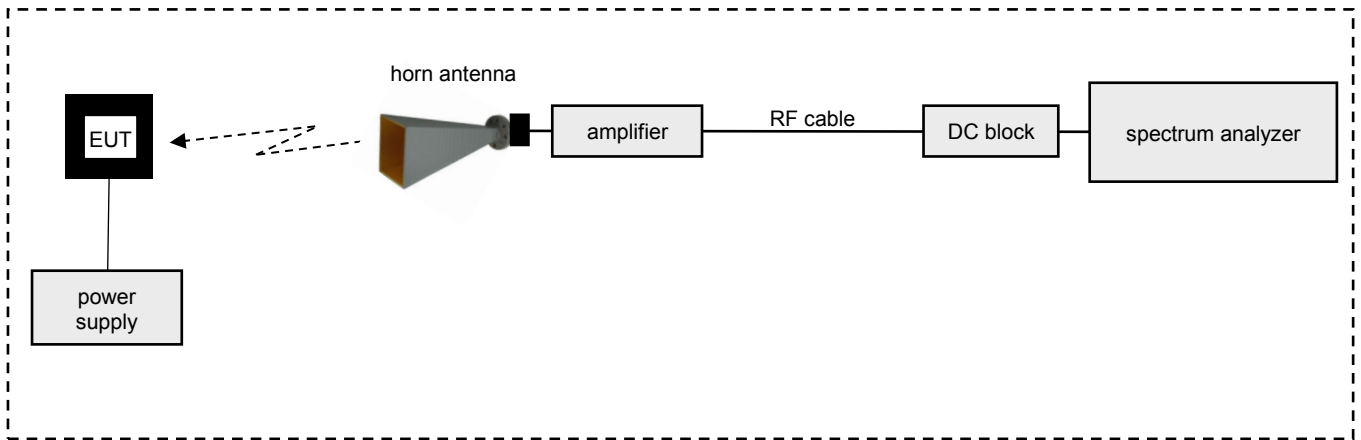

**List of test equipment used:**

No.	Equipment	Manufacturer	Type	Serial No.	INV. No.	Last / Next Calibration
1	Test table	innco systems GmbH	PT0707-RH light	-	LAB000303	N/A
2	WG-Coax-Adapter	Flann Microwave Ltd	20093-TF30 UBR220	273374	LAB000181	N/A
3	Coaxial Cable	Huber & Suhner	SF101/1.5m	503987/1	LAB000165	N/A
4	Antenna	Flann Microwave Ltd	20240-20	266403	LAB000128	2023-06-29 → 2026-06-29
4	Antenna	Flann Microwave Ltd	20240-20	270447	LAB000129	2023-07-01 → 2026-07-01
6	Spectrum Analyser	Rohde & Schwarz	FSW43	101391	LAB000289	2022-09-23 → 2023-09-23



### 8.4 Conducted measurements WLAN test system R&S TS 8997

The EUT's RF signal is coupled out by the antenna connector which is supplied by the manufacturer. The losses for all signal paths are first checked within a calibration. The measurement readings on the signalling unit/spectrum analyzer are corrected by the specific test set-up loss. The attenuator, power divider, signalling unit and the spectrum analyzer are impedance matched on 50 Ohm.

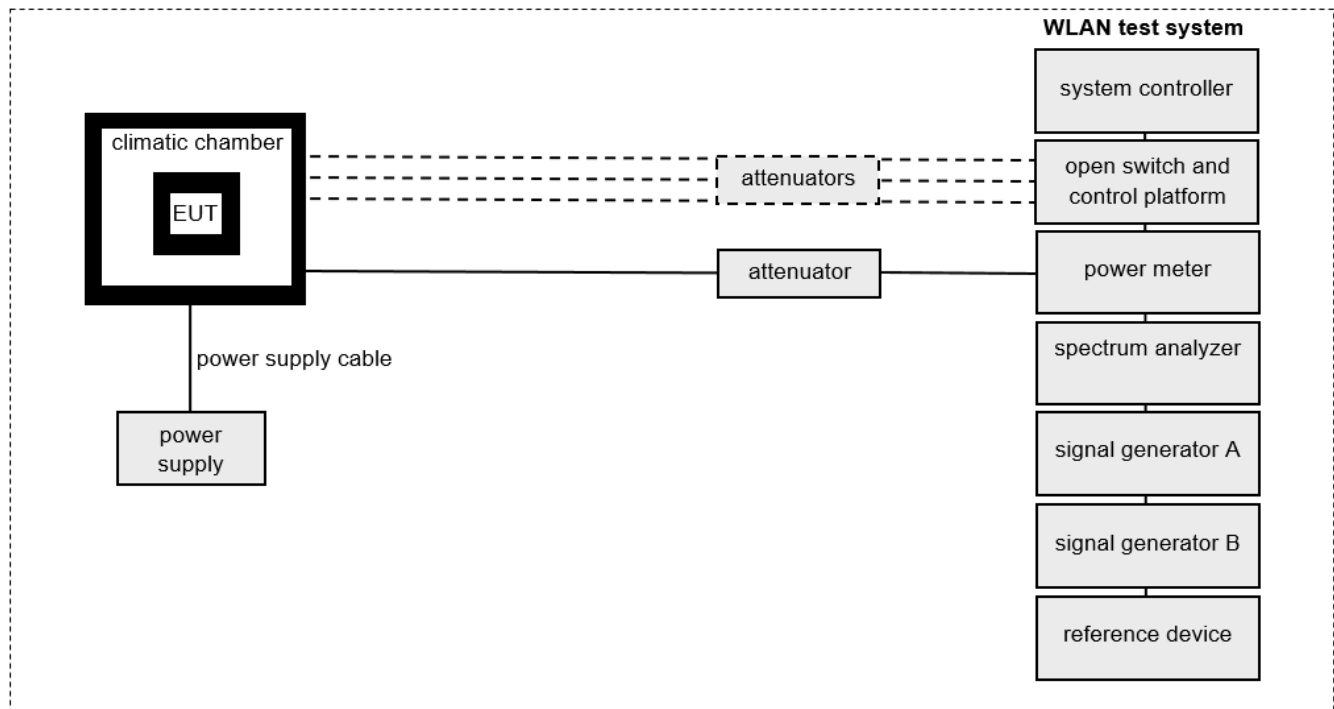

EMC32/WMS32 software version: 11.00.00

**List of test equipment used:**

No.	Equipment	Manufacturer	Type	Serial No.	INV. No.	Last / Next Calibration
1	TS8997-Rack	Rohde & Schwarz	TS8997-Rack	100829	LAB000322	N/A
2	Open Switch and Control Platform	Rohde & Schwarz	OSP-B157WX	101247	LAB000280	N/A
3	Open Switch and Control Platform	Rohde & Schwarz	OSP-B157W8	100982	LAB000279	N/A
4	Spectrum Analyser	Rohde & Schwarz	FSV40	101403	LAB000278	2021-06-15 → 2024-06-15
5	Signal Generator	Rohde & Schwarz	SMBV100A	258240	LAB000277	2021-08-31 → 2024-08-31
6	Signal Generator	Rohde & Schwarz	SMB100A-20	178175	LAB000276	2021-05-27 → 2024-05-31
7	Radio Communication Tester	Rohde & Schwarz	CMW270	101479	LAB000275	N/A
8	Controller	Hewlett Packard	ATS-Z230	101379	LAB000274	N/A
9	Power Supply	EA	PS 2042-10 B	2878350263	LAB000190	N/A

## 9 MEASUREMENT UNCERTAINTIES

Radio frequency	$\leq \pm 1 \times 10^{-7}$
RF power, conducted	$\leq \pm 0.75$ dB
Power spectral density	$\leq \pm 3$ dB
Maximum frequency deviation	$\leq \pm 5$ %
Deviation limitation Duty Cycle, Tx-sequence, Tx-gap	$\leq \pm 5$ %
Occupied channel bandwidth	$\leq \pm 5$ %
Conducted spurious emission of transmitter	$\leq \pm 4$ dB
Conducted emission of receivers	$\leq \pm 4$ dB
Radiated emission of transmitter	$\leq \pm 6$ dB
Radiated emission of receiver	$\leq \pm 6$ dB
Temperature	$\leq \pm 2.5$ °C
Humidity	$\leq \pm 10$ %

The indicated expanded measurement uncertainty corresponds to the standard measurement uncertainty for the measurement results multiplied by the coverage factor  $k = 2$ . It was determined in accordance with EA-4/02 M:2013. The true value is located in the corresponding interval with a probability of 95 %.

---

**End of Test Report**

---

# Annex A

Test results of EUT

part of / in addition to

**Test report no.:** 23038521-32374-0

Tested by  
(name, function, signature)

*Piotr Sardyko*  
*Lab Manager*



---

signature

Approved by  
(name, function, signature)

*Andreas Bender*  
*Deputy Managing Director*



---

signature

## TABLE OF CONTENTS

TABLE OF CONTENTS.....	2
TEST RESULTS .....	3
Radiated peak power .....	3
EUT No 79.....	3
EUT No 80.....	14
Band Edge Compliance (BEC) .....	25
EUT No 79.....	25
EUT No 80.....	37
Radiated Spurious Emissions (RSE).....	49
EUT No 79.....	49
EUT No 80.....	91
Revision History .....	133

## TEST RESULTS

### Radiated peak power

#### EUT No 79

1. Test: Radiated peak power, EUT No: 79, SN: R0091, Mode 1, a-mode, channel 36, 5180 MHz, 20 MHz channel bandwidth

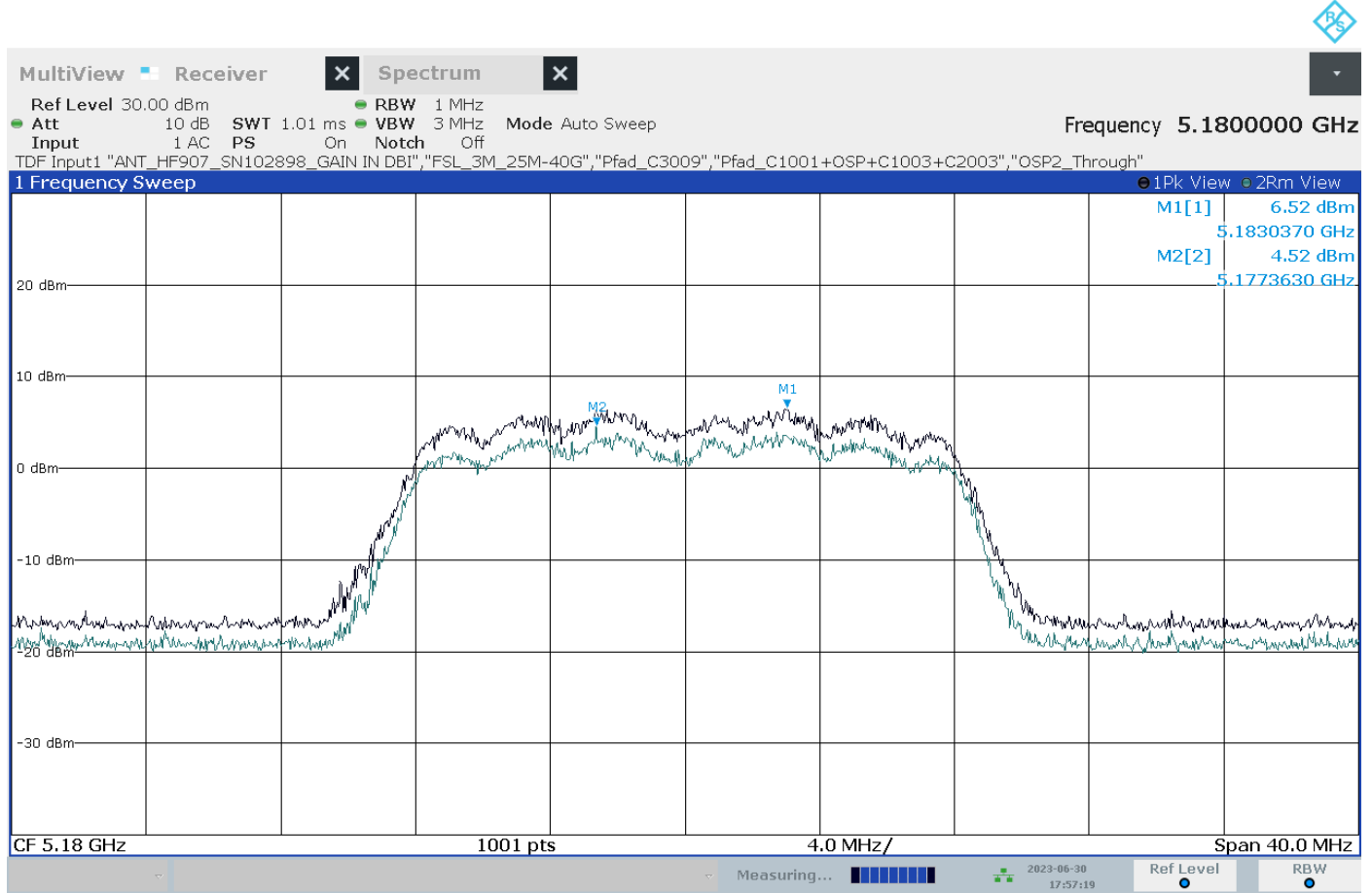

05:57:20 06/30/2023

Annex A of TR no.: 23038521-32374-0

- Test: Radiated peak power, EUT No: 79, SN: R0091, Mode 1, a-mode, channel 48, 5240 MHz, 20 MHz channel bandwidth

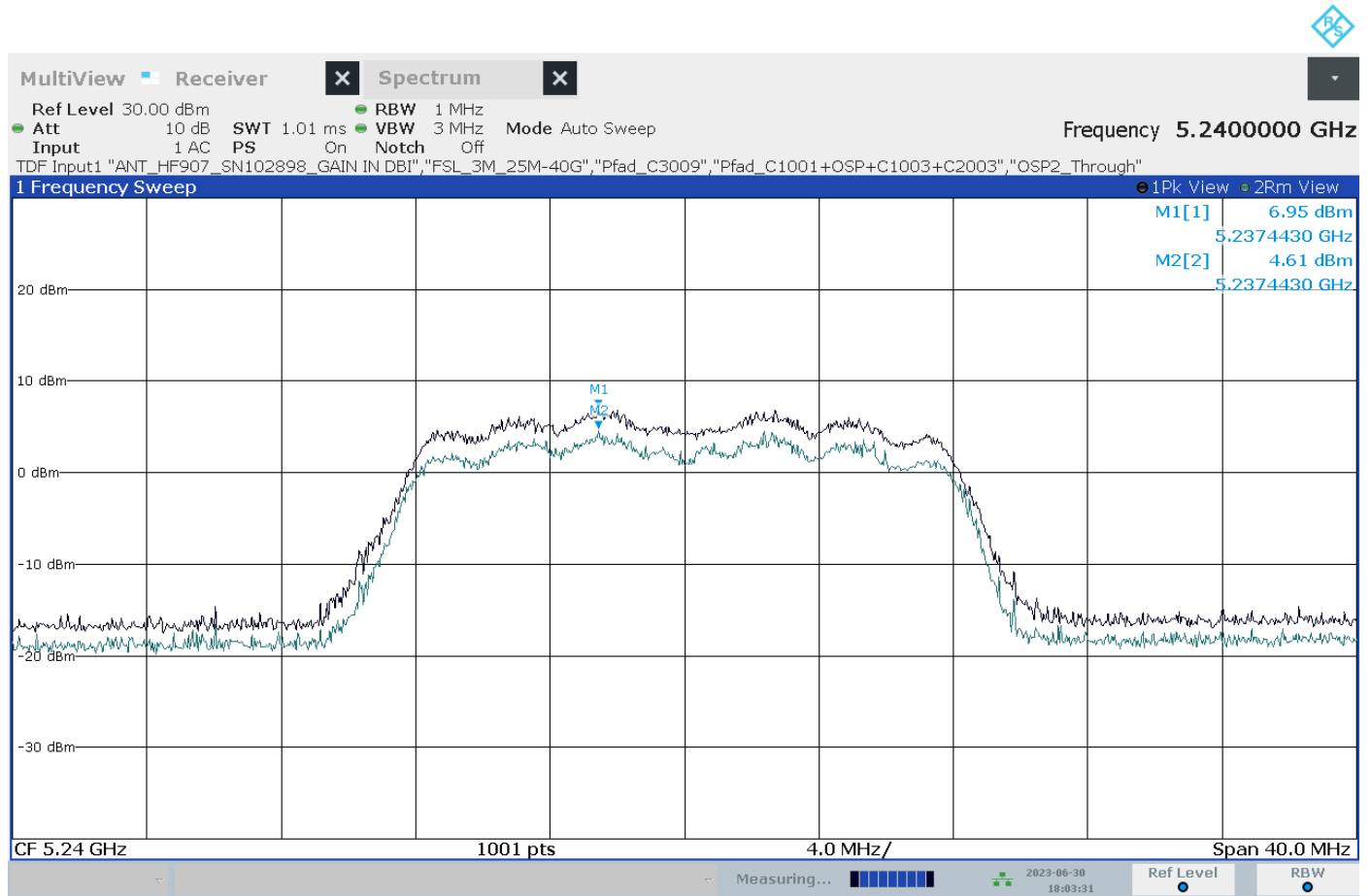

06:03:31 06/30/2023

Annex A of TR no.: 23038521-32374-0

- Test: Radiated peak power, EUT No: 79, SN: R0091, Mode 1, a-mode, channel 52, 5260 MHz, 20 MHz channel bandwidth

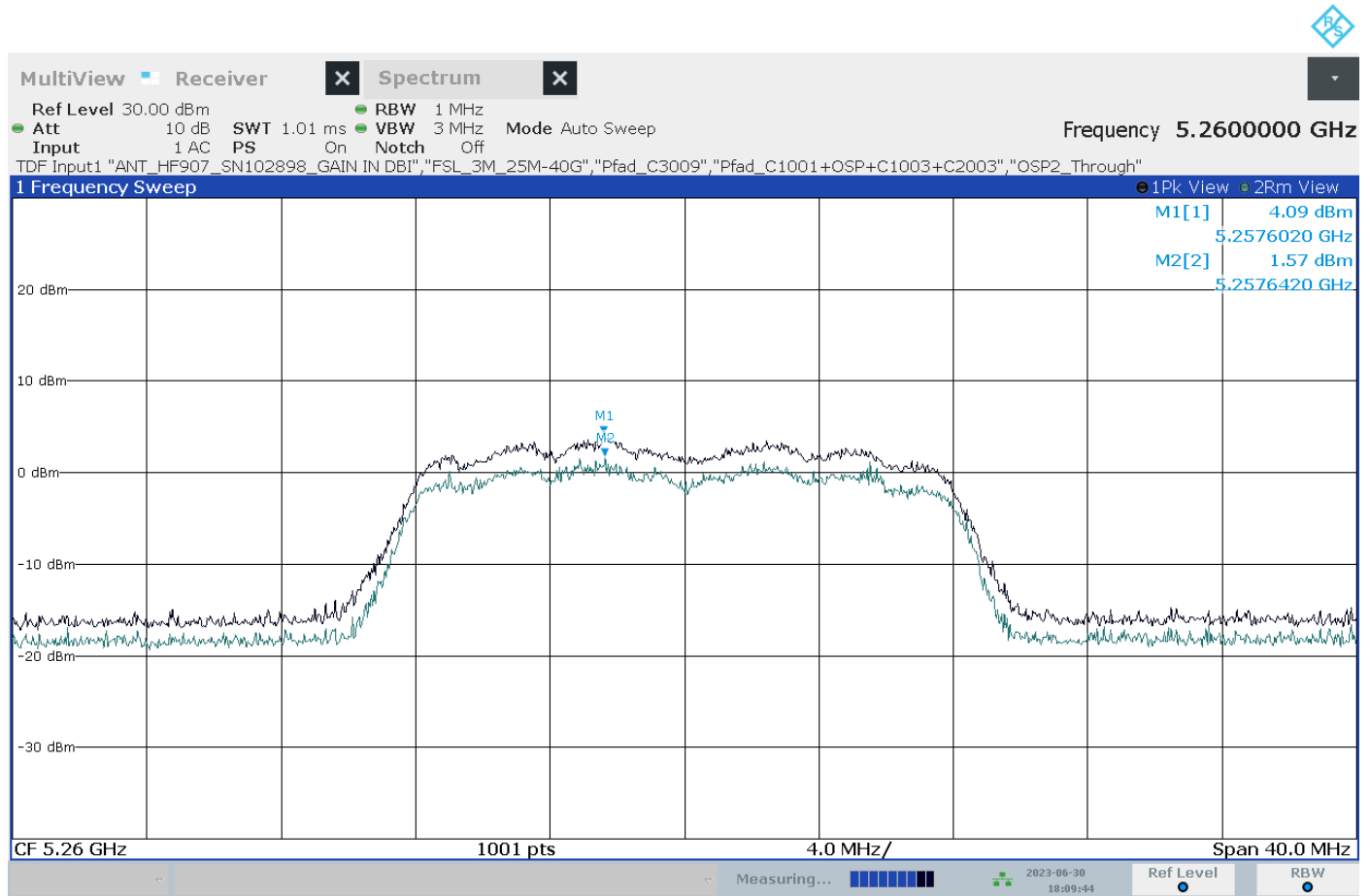

06:09:44 06/30/2023

Annex A of TR no.: 23038521-32374-0

4. Test: Radiated peak power, EUT No: 79, SN: R0091, Mode 1, a-mode, channel 64, 5320 MHz, 20 MHz channel bandwidth

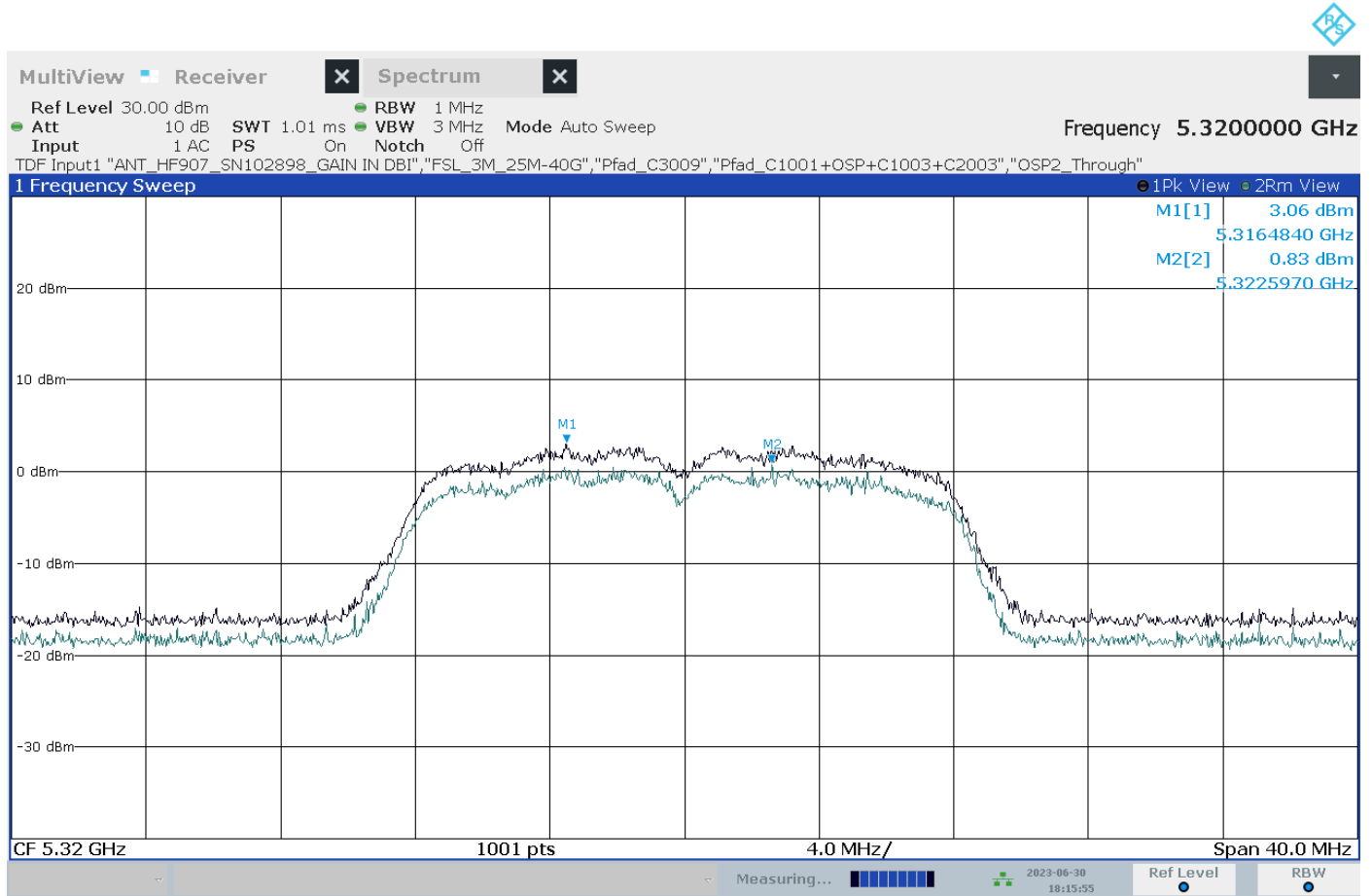

06:15:55 06/30/2023



Annex A of TR no.: 23038521-32374-0

- 5. Test: Radiated peak power, EUT No: 79, SN: R0091, Mode 1, a-mode, channel 100, 5500 MHz, 20 MHz channel bandwidth

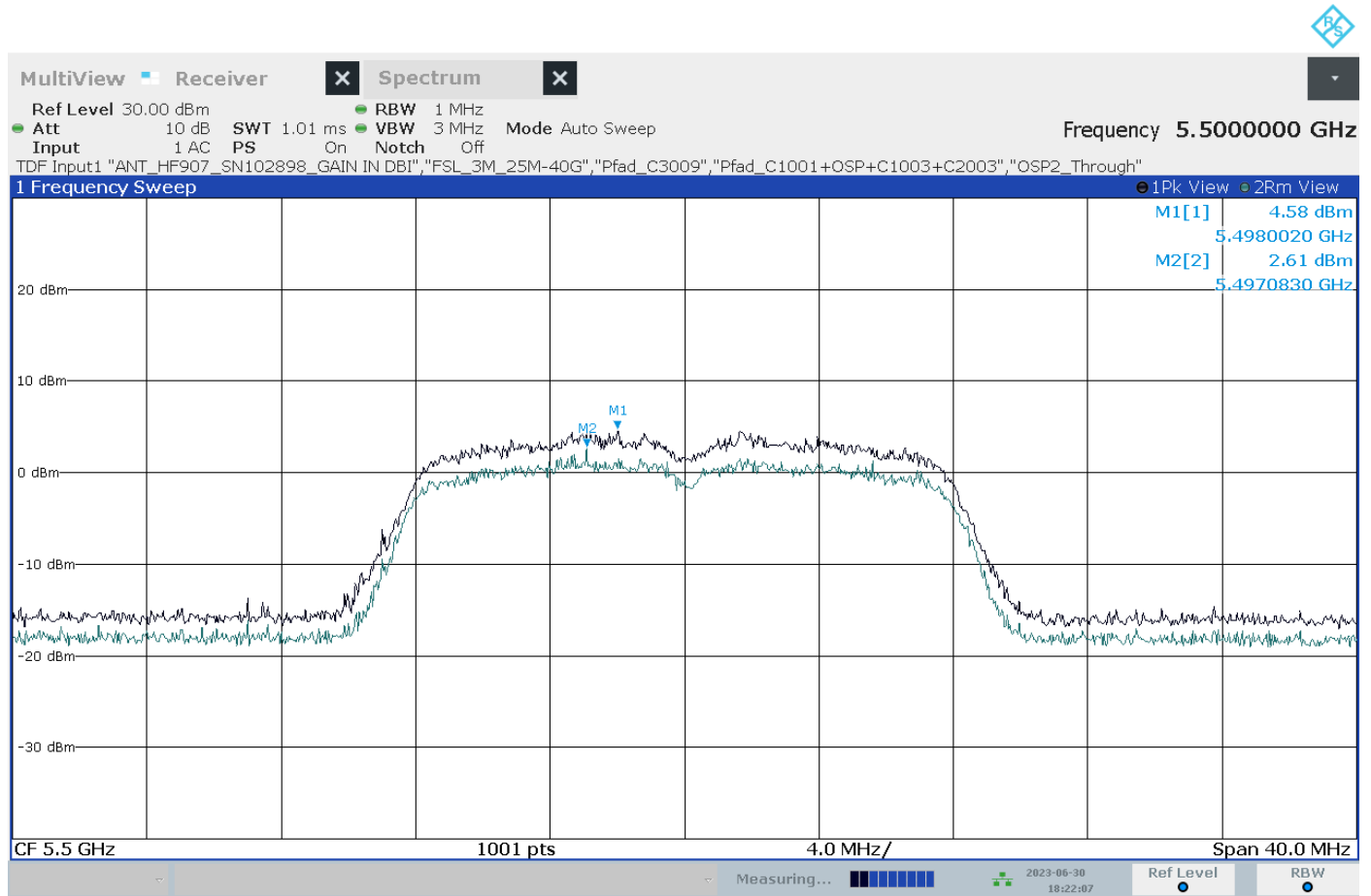

06:22:07 06/30/2023

Annex A of TR no.: 23038521-32374-0

6. Test: Radiated peak power, EUT No: 79, SN: R0091, Mode 1, a-mode, channel 120, 5600 MHz, 20 MHz channel bandwidth

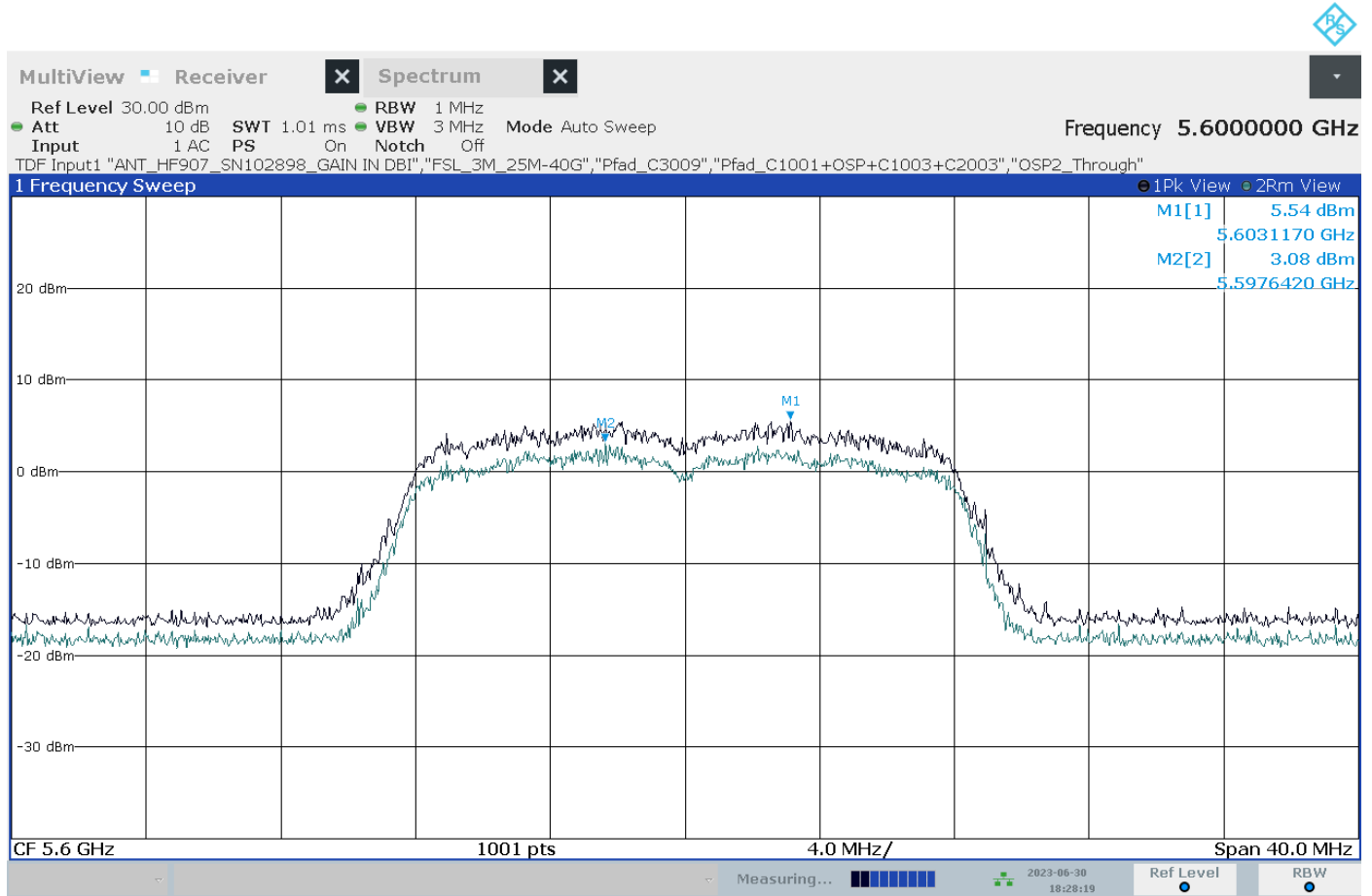

06:28:20 06/30/2023

Annex A of TR no.: 23038521-32374-0

7. Test: Radiated peak power, EUT No: 79, SN: R0091, Mode 1, a-mode, channel 140, 5700 MHz, 20 MHz channel bandwidth

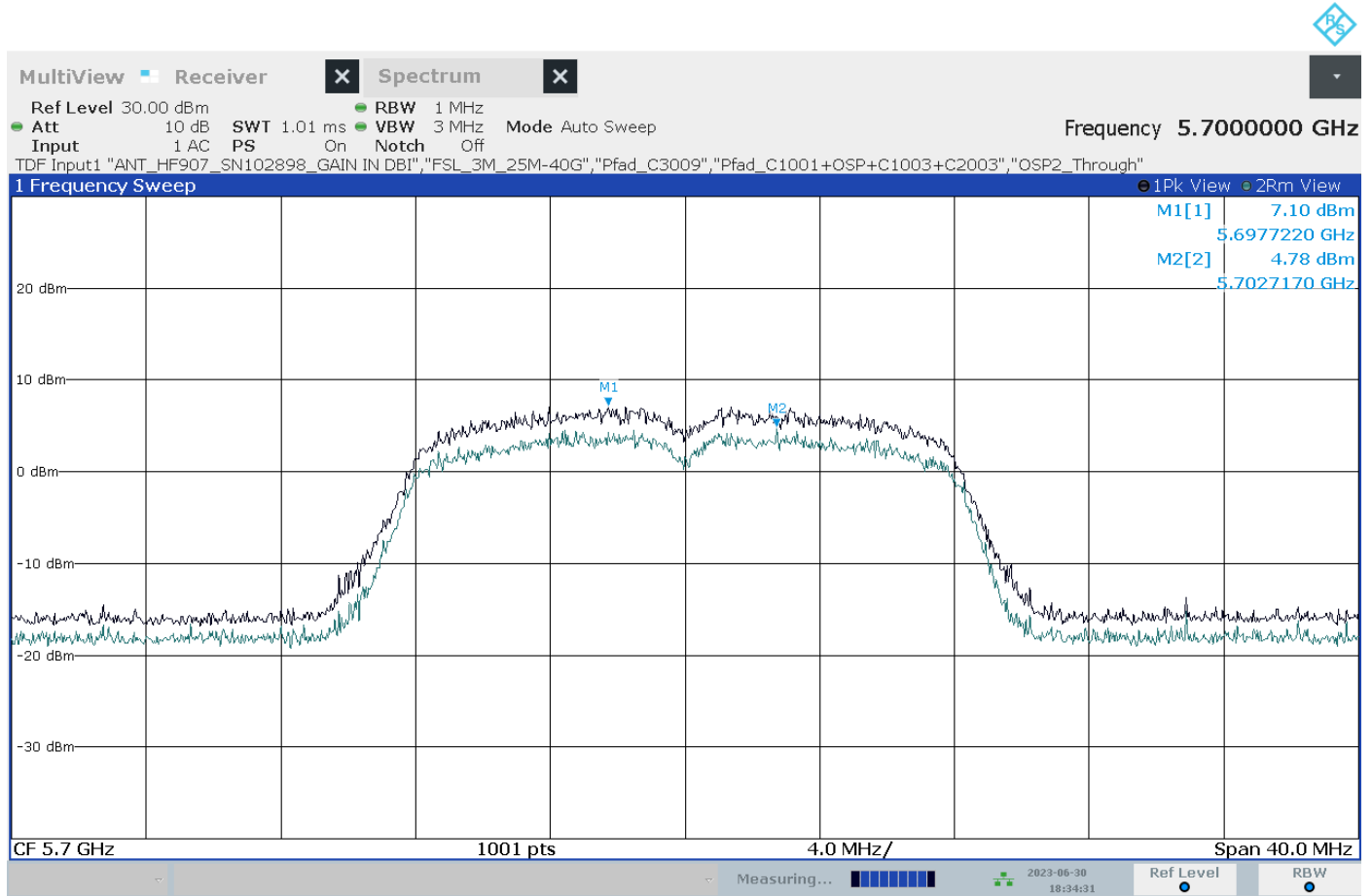

06:34:32 06/30/2023

Annex A of TR no.: 23038521-32374-0

- 8. Test: Radiated peak power, EUT No: 79, SN: R0091, Mode 1, a-mode, channel 144, 5720 MHz, 20 MHz channel bandwidth

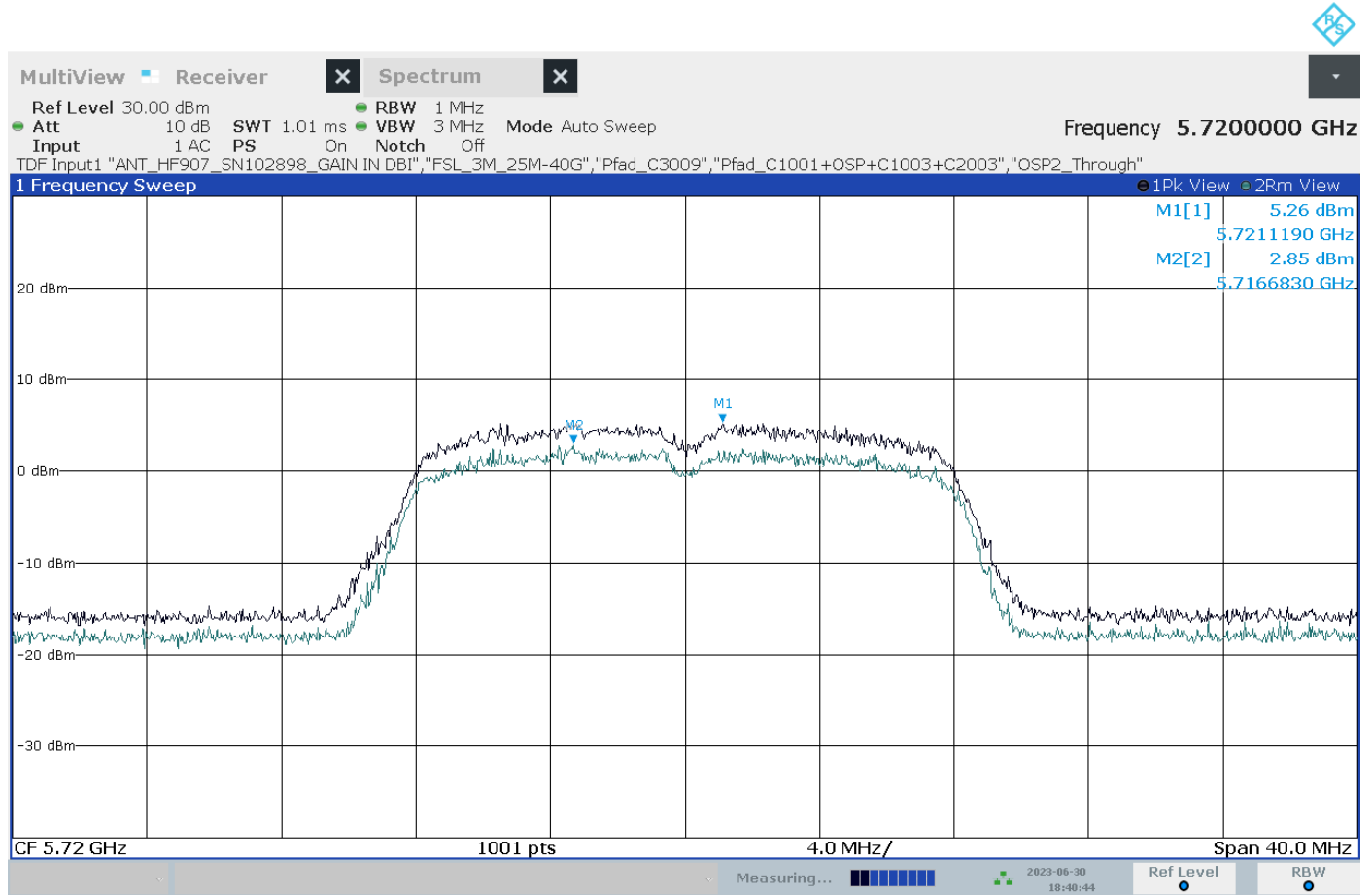

06:40:45 06/30/2023

Annex A of TR no.: 23038521-32374-0

9. Test: Radiated peak power, EUT No: 79, SN: R0091, Mode 1, a-mode, channel 149, 5745 MHz, 20 MHz channel bandwidth

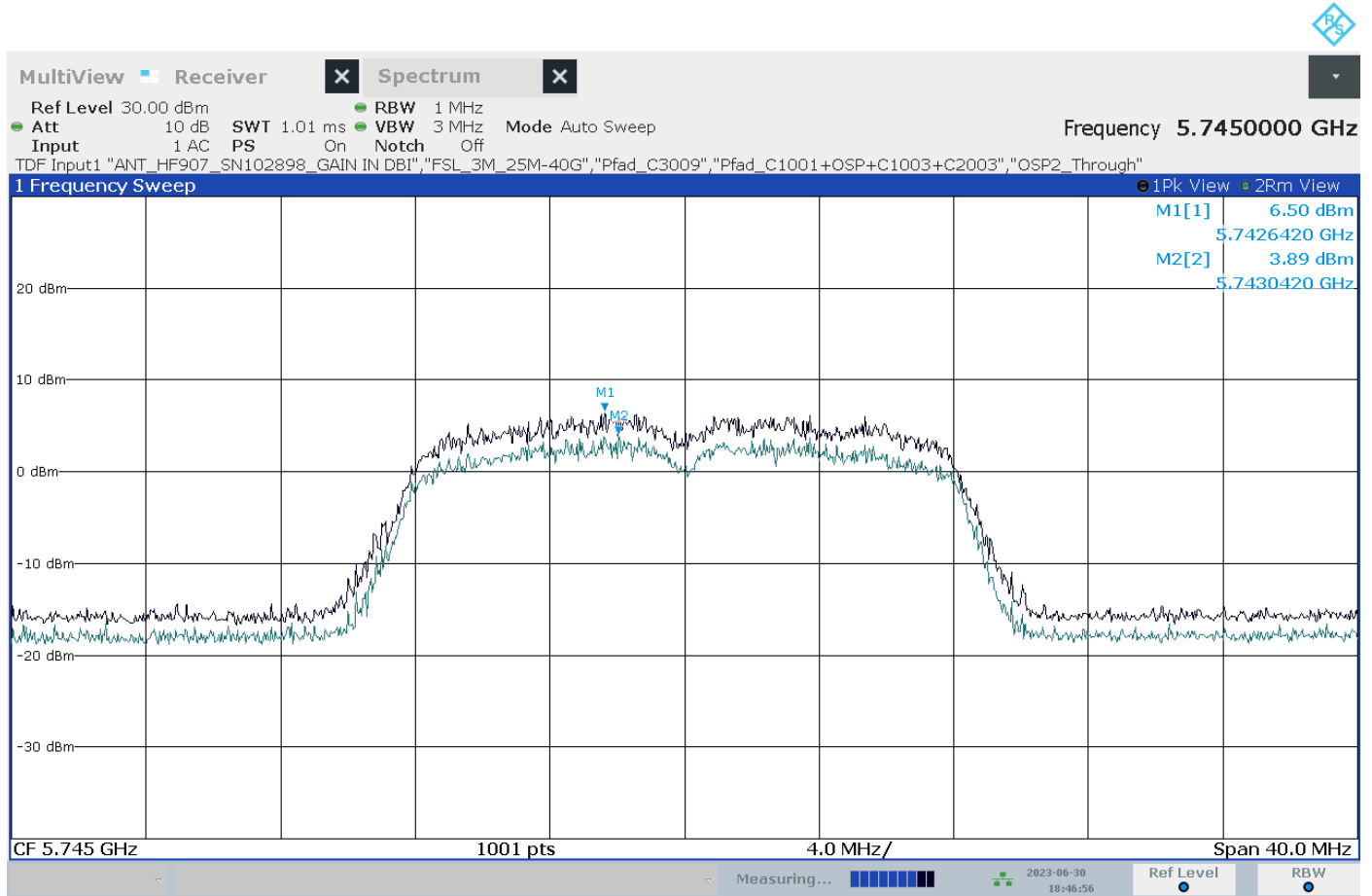

06:46:57 06/30/2023

Annex A of TR no.: 23038521-32374-0

10. Test: Radiated peak power, EUT No: 79, SN: R0091, Mode 1, a-mode, channel 157, 5785 MHz, 20 MHz channel bandwidth

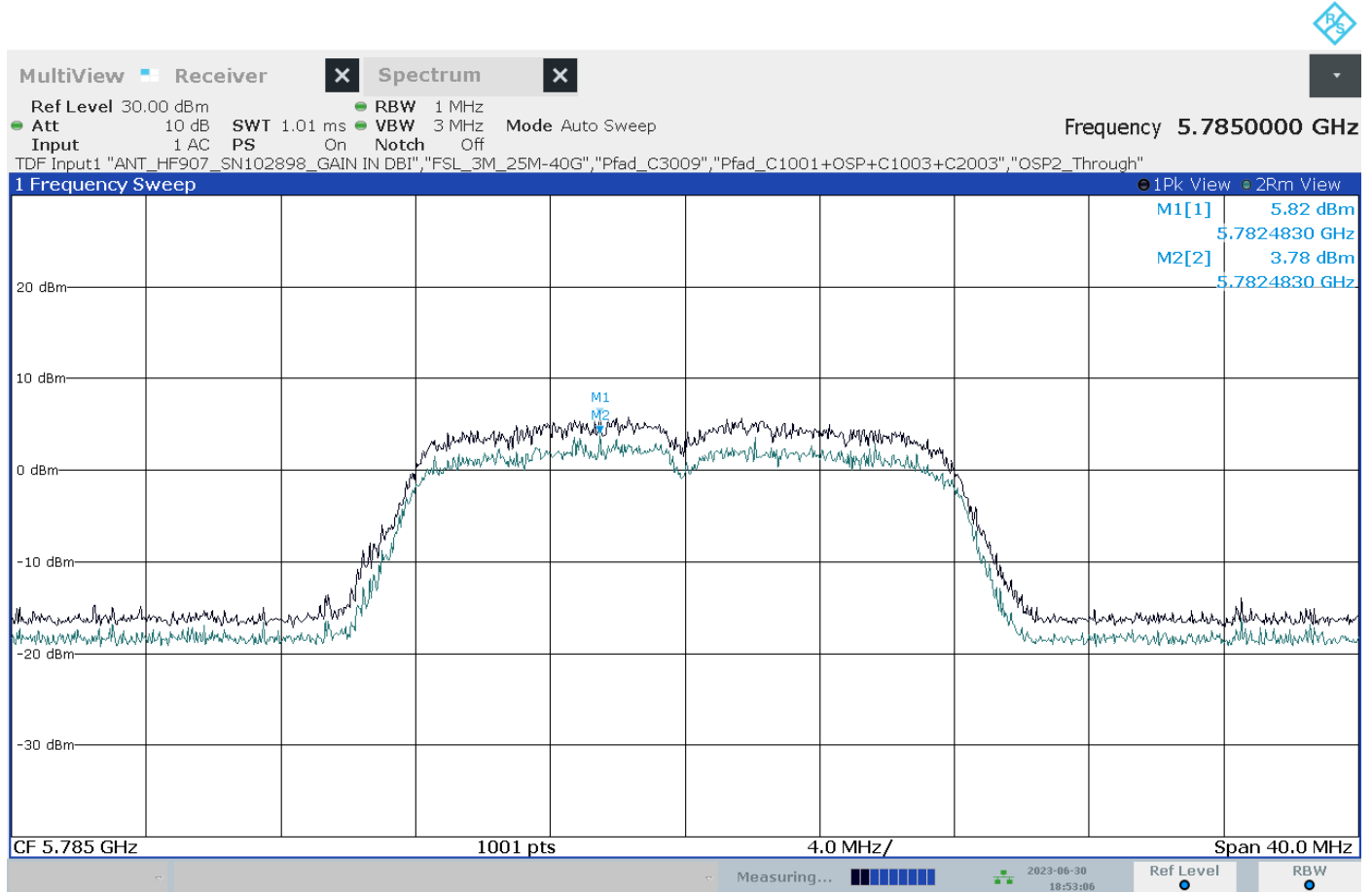

06:53:07 06/30/2023

Annex A of TR no.: 23038521-32374-0

11. Test: Radiated peak power, EUT No: 79, SN: R0091, Mode 1, a-mode, channel 165, 5825 MHz, 20 MHz channel bandwidth

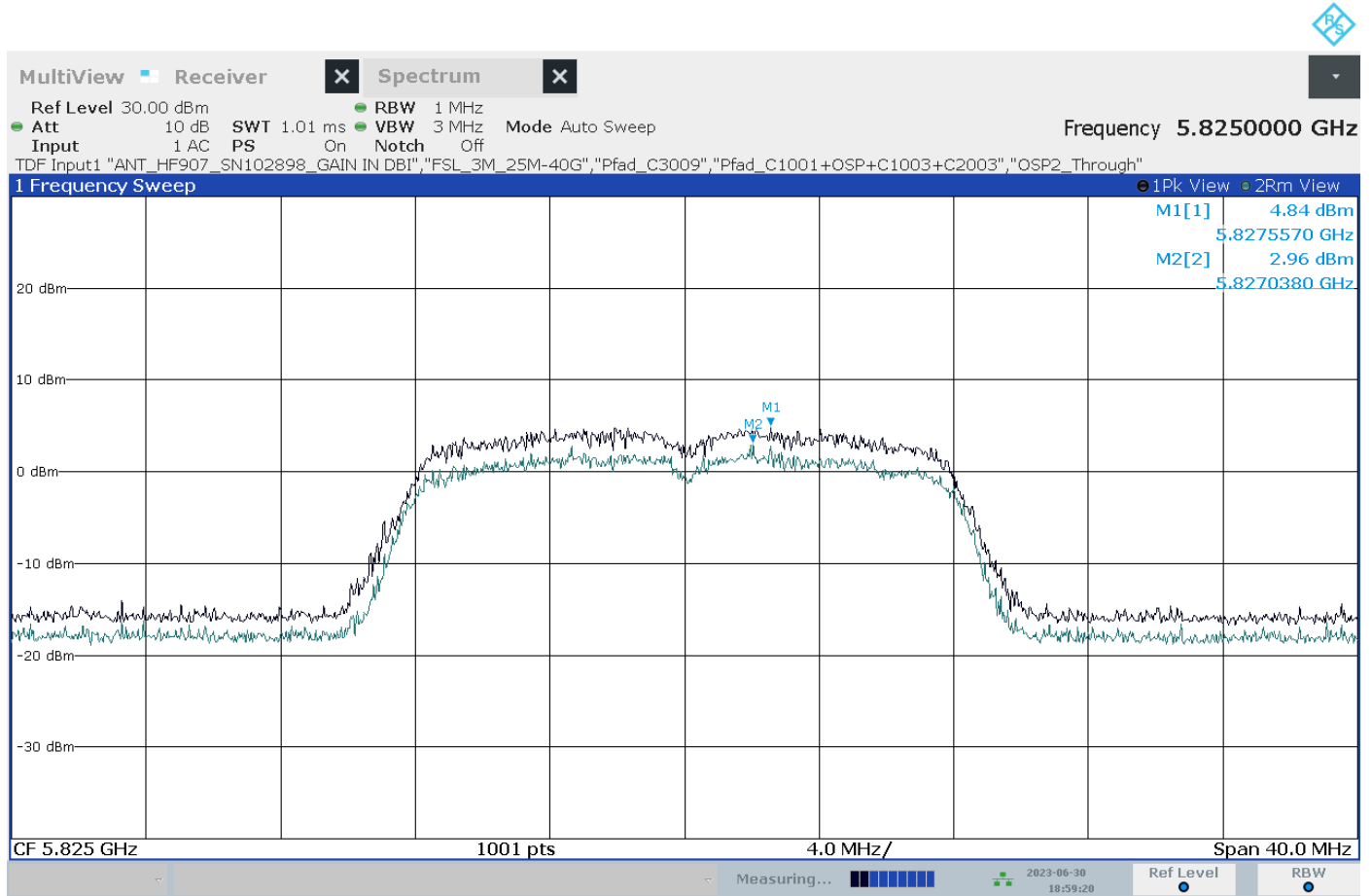

06:59:20 06/30/2023

### EUT No 80

12. Test: Radiated peak power, EUT No: 80, SN: R0047, Mode 1, a-mode, channel 36, 5180 MHz, 20 MHz channel bandwidth

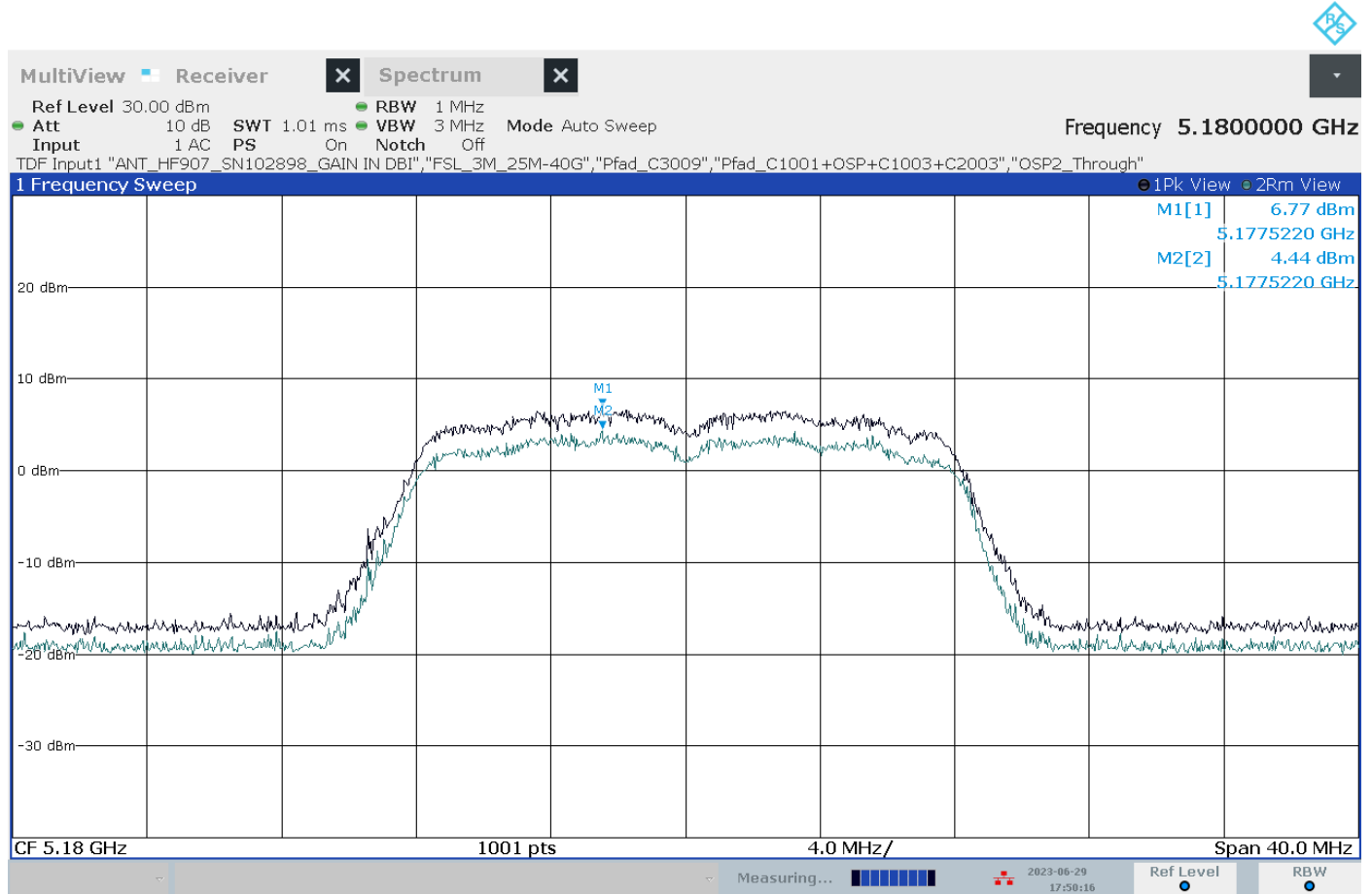

05:50:17 06/29/2023



Annex A of TR no.: 23038521-32374-0

13. Test: Radiated peak power, EUT No: 80, SN: R0047, Mode 1, a-mode, channel 48, 5240 MHz, 20 MHz channel bandwidth

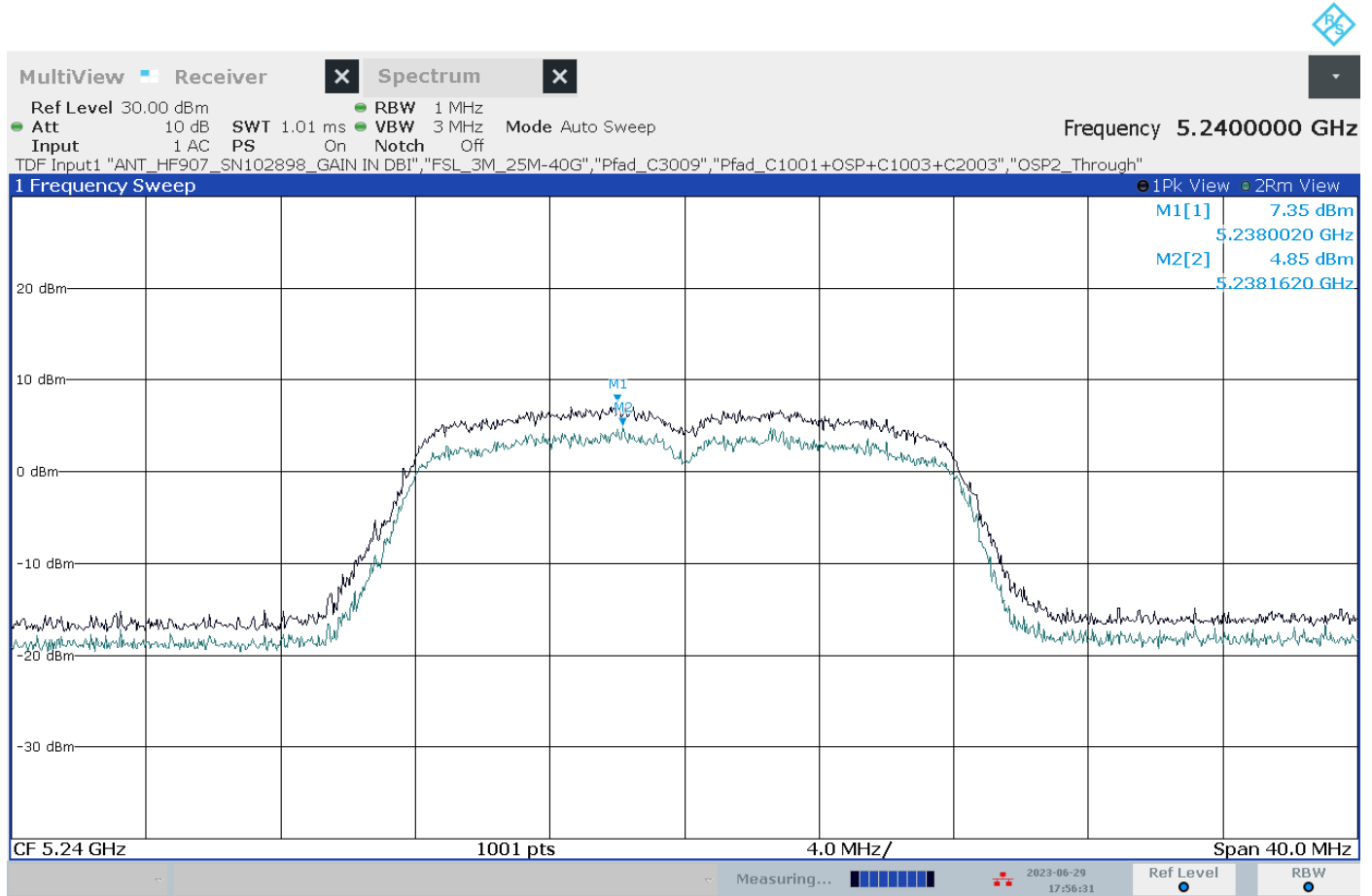

05:56:32 06/29/2023

Annex A of TR no.: 23038521-32374-0

14. Test: Radiated peak power, EUT No: 80, SN: R0047, Mode 1, a-mode, channel 52, 5260 MHz, 20 MHz channel bandwidth

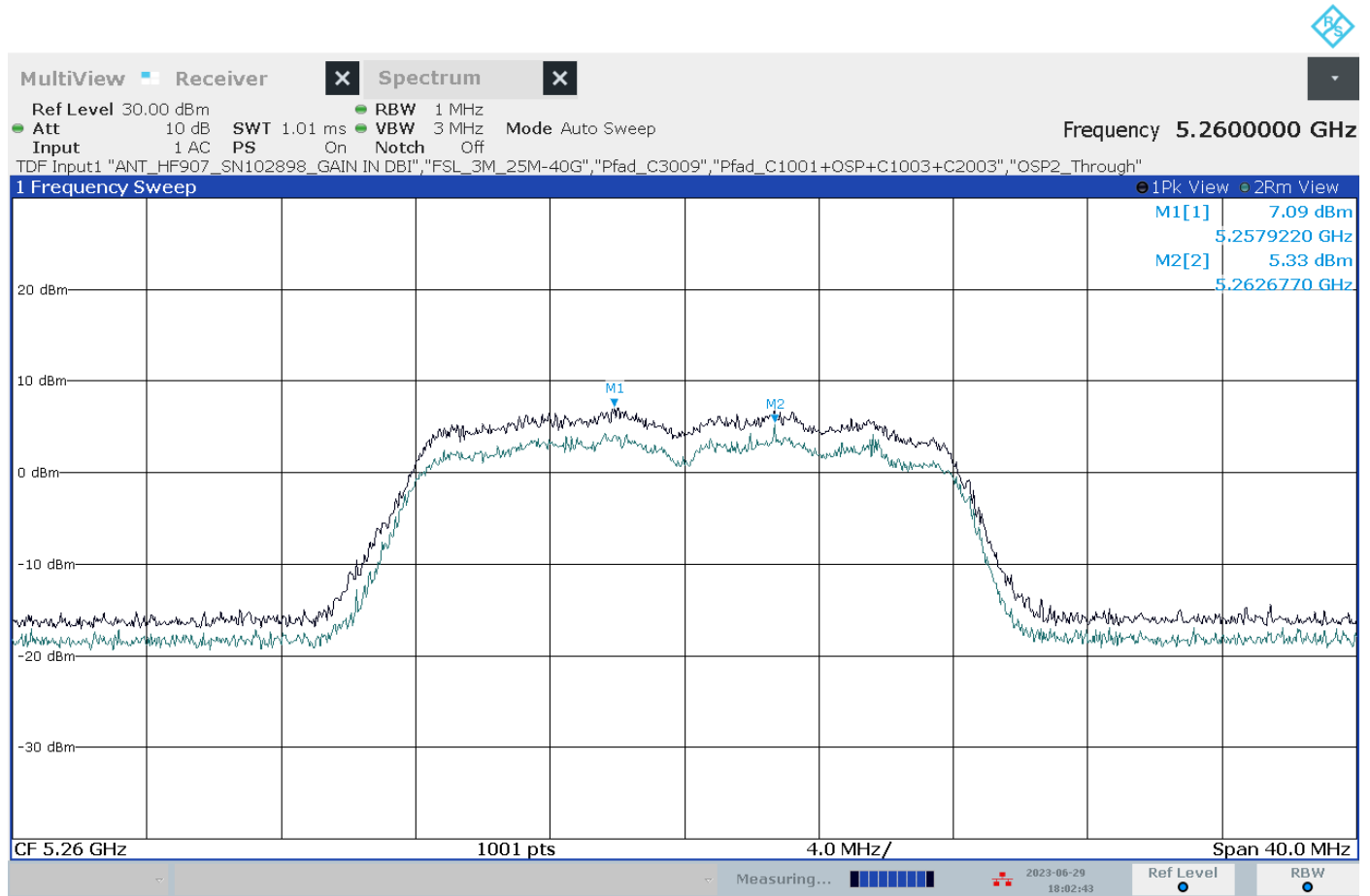

06:02:43 06/29/2023

Annex A of TR no.: 23038521-32374-0

15. Test: Radiated peak power, EUT No: 80, SN: R0047, Mode 1, a-mode, channel 64, 5320 MHz, 20 MHz channel bandwidth

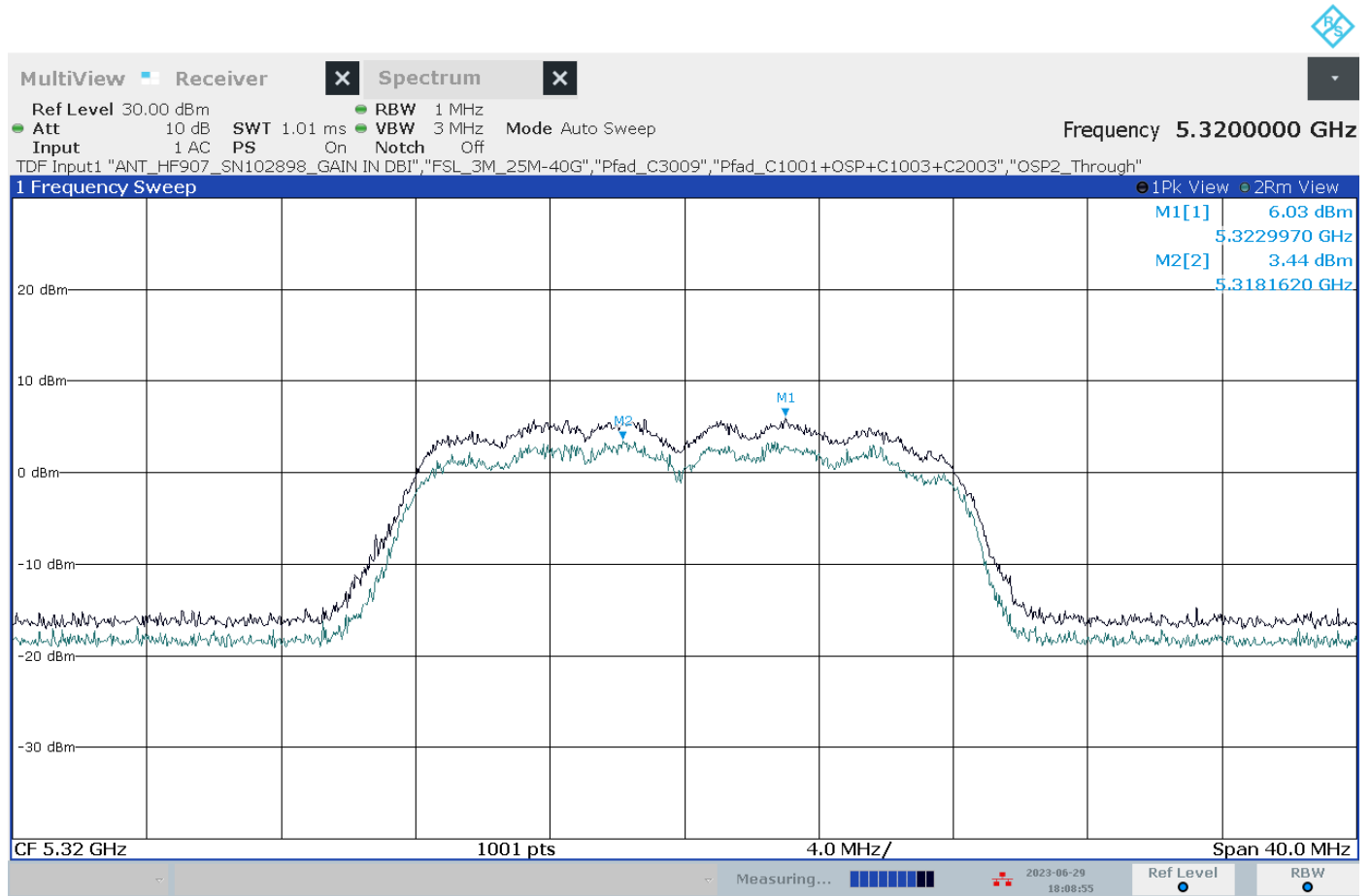

06:08:55 06/29/2023

Annex A of TR no.: 23038521-32374-0

16. Test: Radiated peak power, EUT No: 80, SN: R0047, Mode 1, a-mode, channel 100, 5500 MHz, 20 MHz channel bandwidth

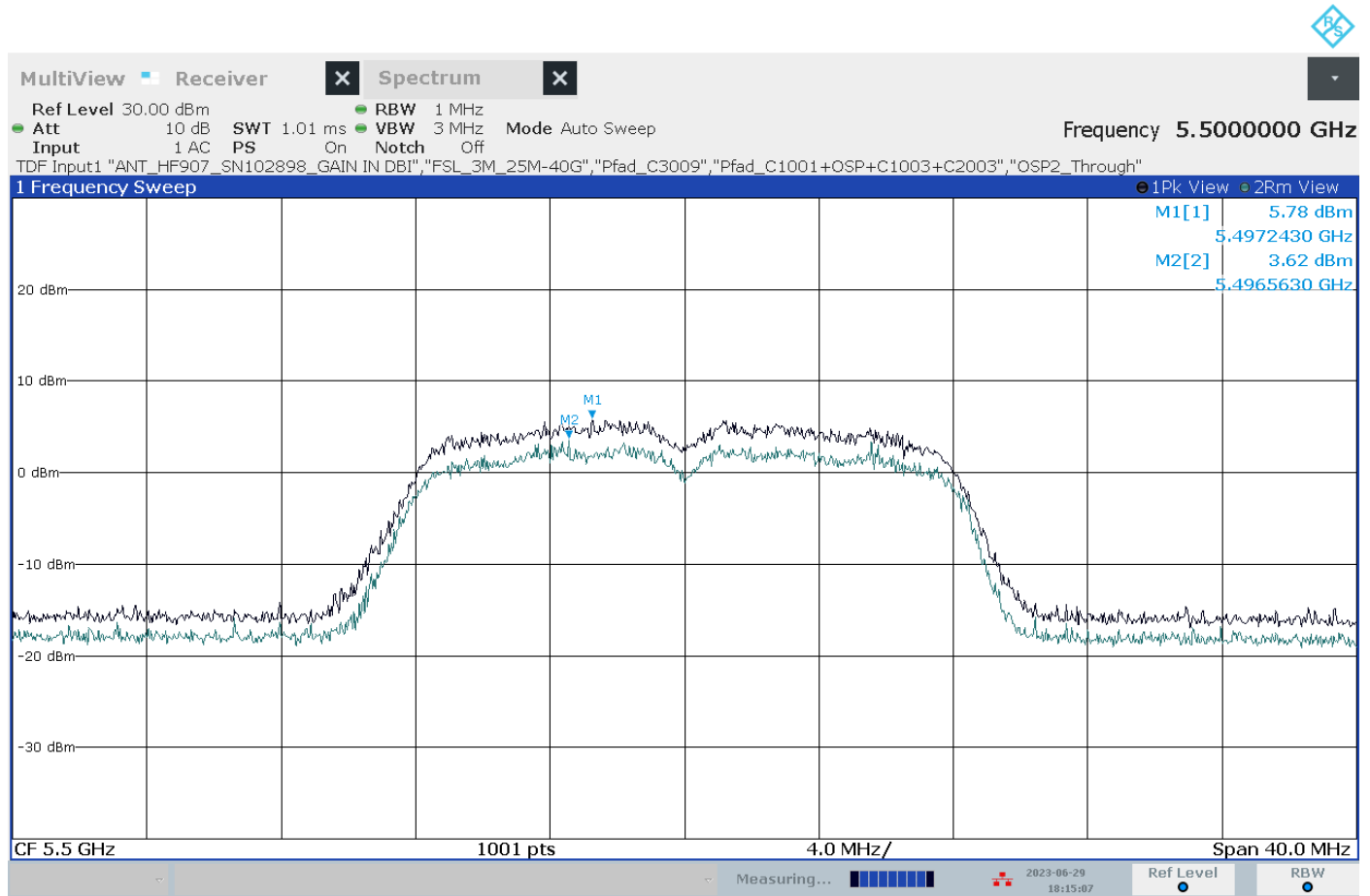

06:15:08 06/29/2023

Annex A of TR no.: 23038521-32374-0

17. Test: Radiated peak power, EUT No: 80, SN: R0047, Mode 1, a-mode, channel 120, 5600 MHz, 20 MHz channel bandwidth

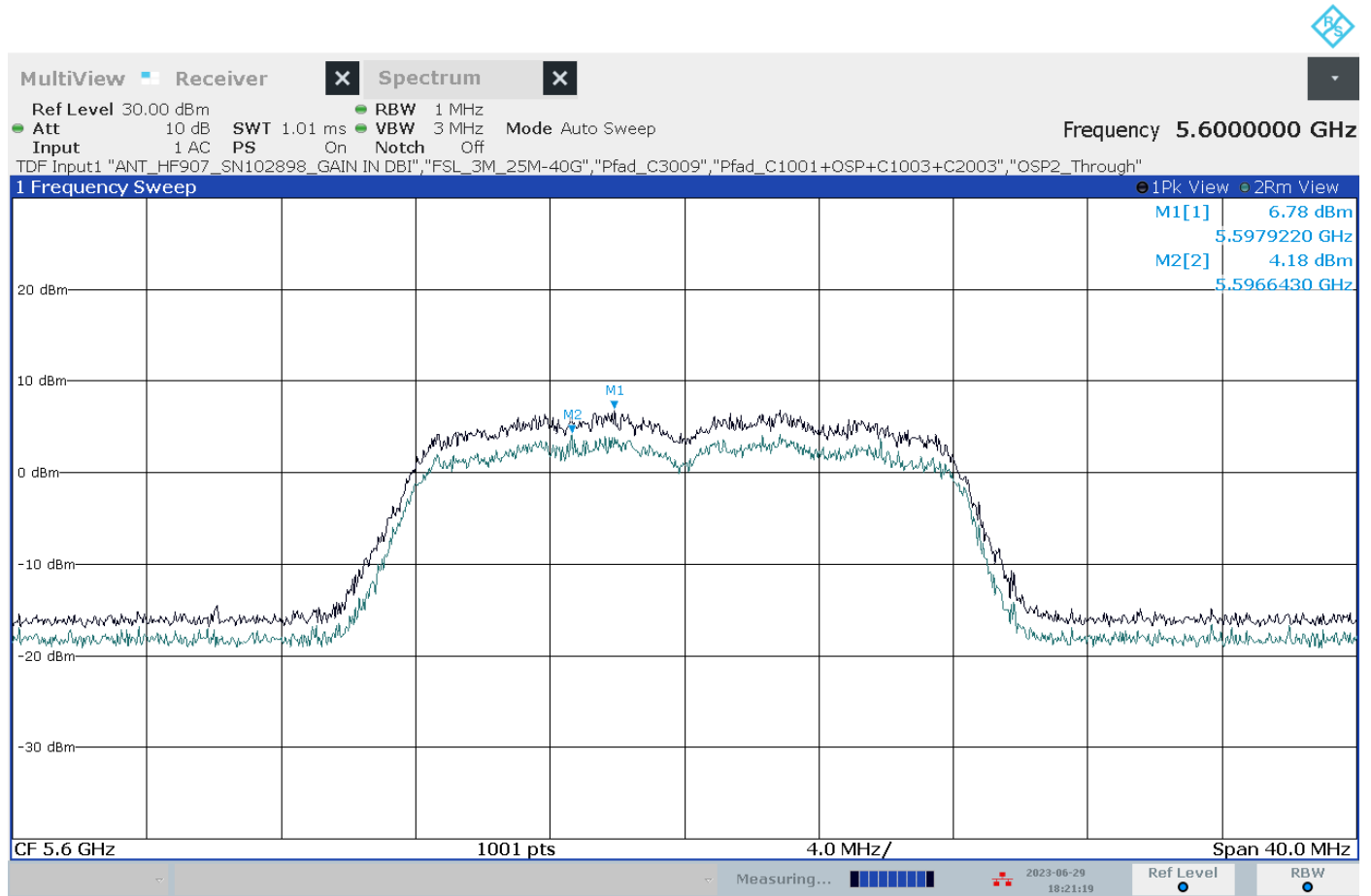

06:21:20 06/29/2023

Annex A of TR no.: 23038521-32374-0

18. Test: Radiated peak power, EUT No: 80, SN: R0047, Mode 1, a-mode, channel 140, 5700 MHz, 20 MHz channel bandwidth

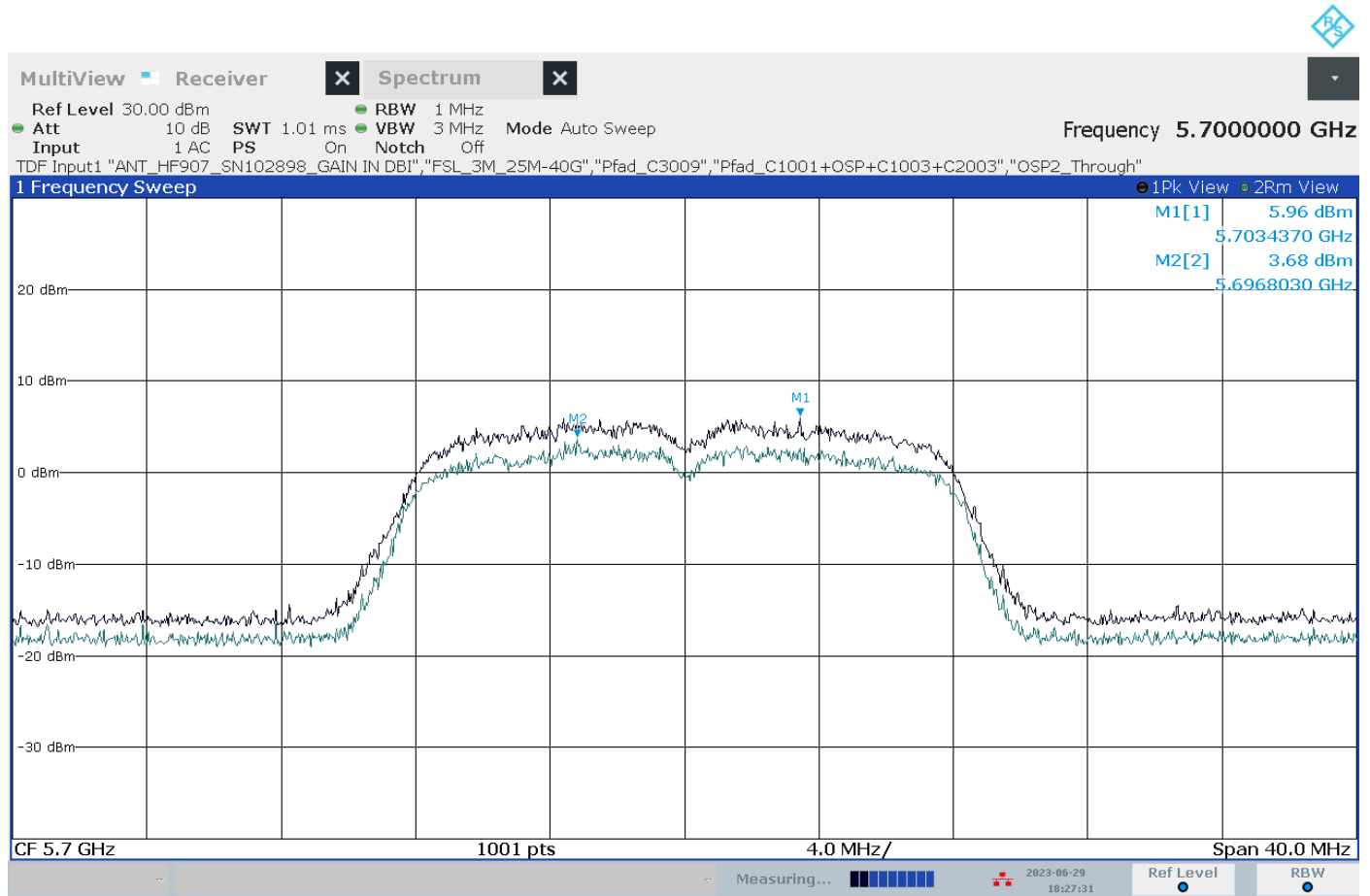

06:27:31 06/29/2023

Annex A of TR no.: 23038521-32374-0

19. Test: Radiated peak power, EUT No: 80, SN: R0047, Mode 1, a-mode, channel 144, 5720 MHz, 20 MHz channel bandwidth

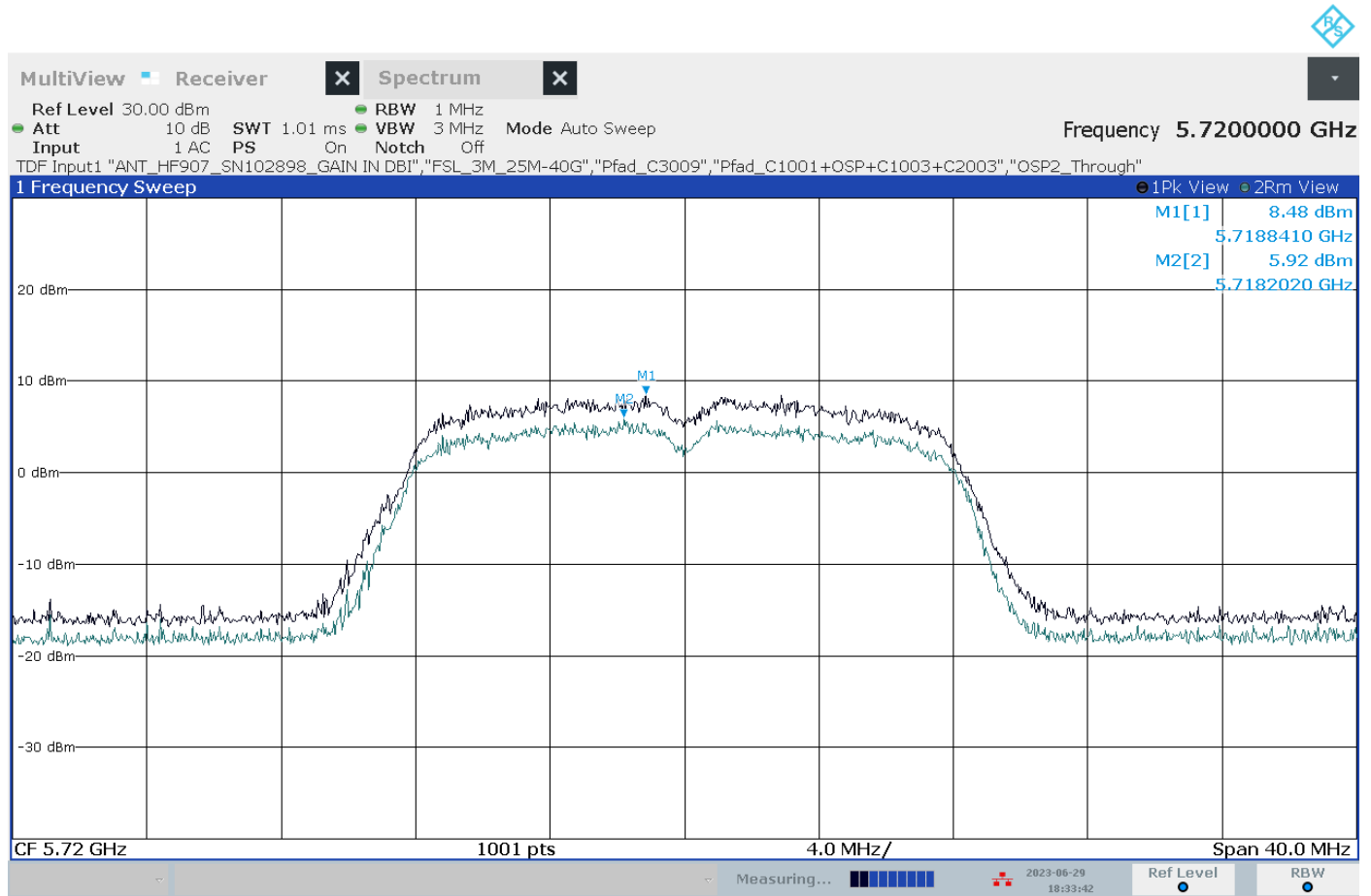

06:33:43 06/29/2023

Annex A of TR no.: 23038521-32374-0

20. Test: Radiated peak power, EUT No: 80, SN: R0047, Mode 1, a-mode, channel 149, 5745 MHz, 20 MHz channel bandwidth

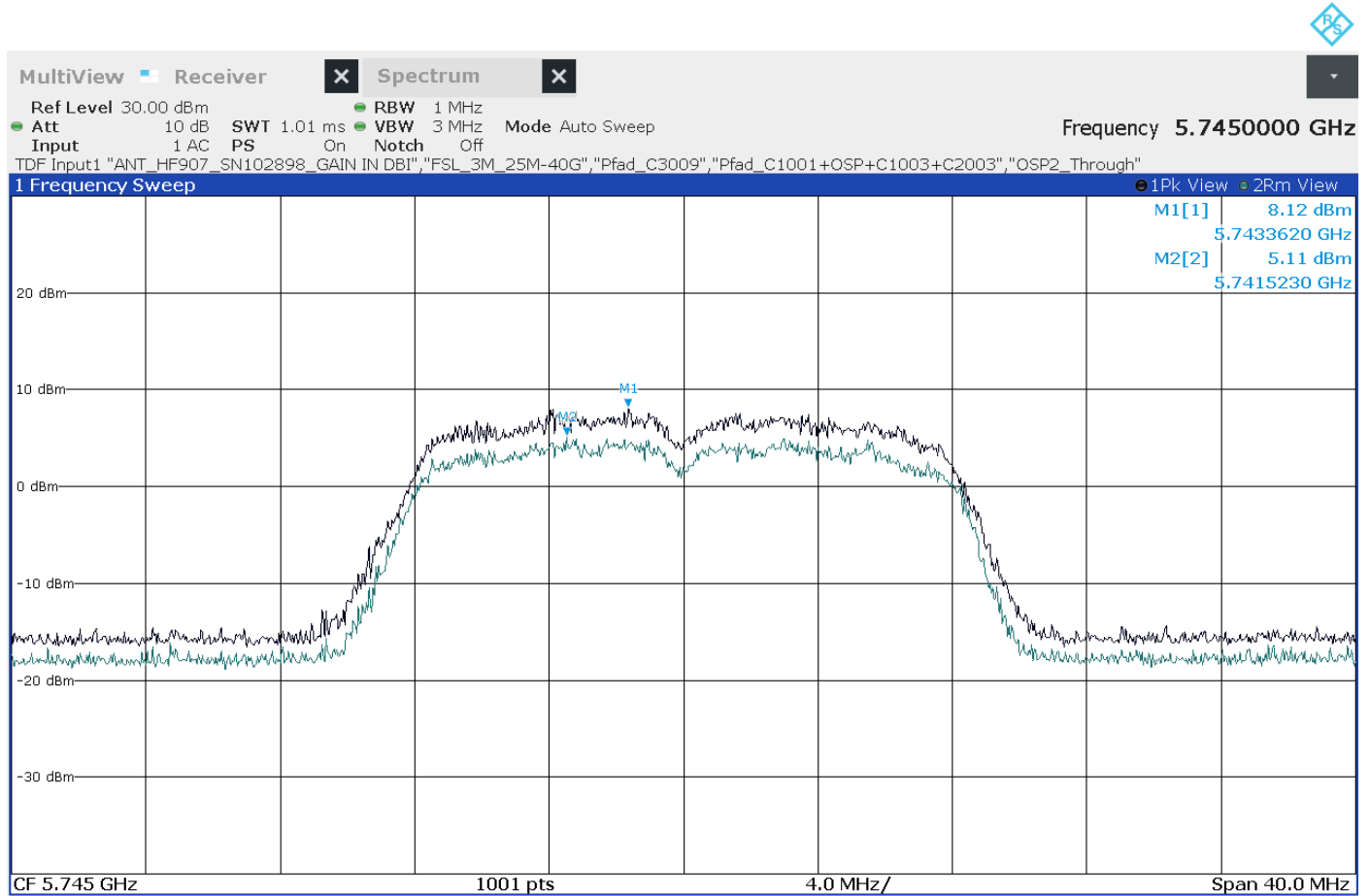

10:41:08 06/30/2023



Annex A of TR no.: 23038521-32374-0

21. Test: Radiated peak power, EUT No: 80, SN: R0047, Mode 1, a-mode, channel 157, 5785 MHz, 20 MHz channel bandwidth

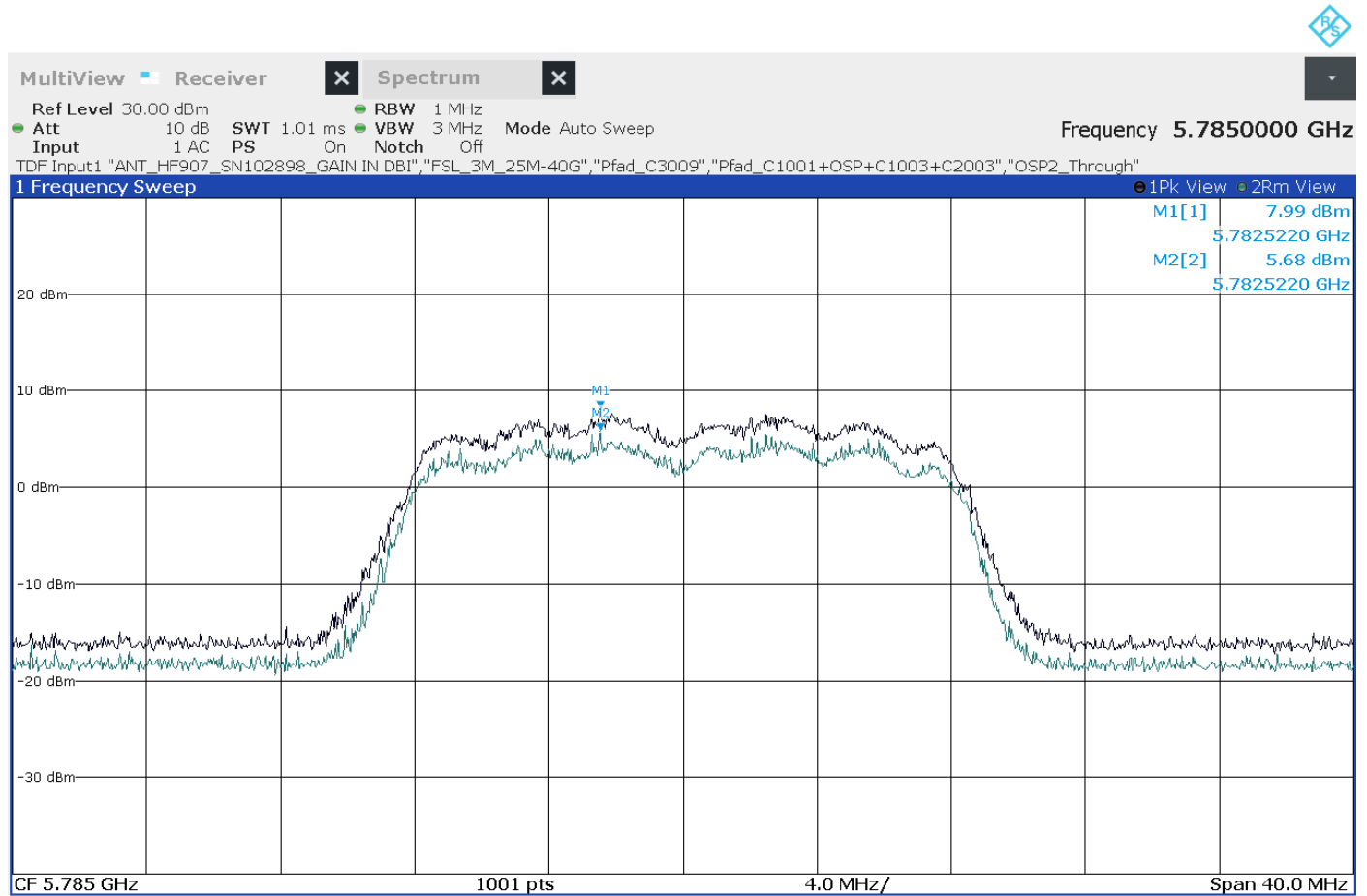

10:47:21 06/30/2023

Annex A of TR no.: 23038521-32374-0

22. Test: Radiated peak power, EUT No: 80, SN: R0047, Mode 1, a-mode, channel 165, 5825 MHz, 20 MHz channel bandwidth

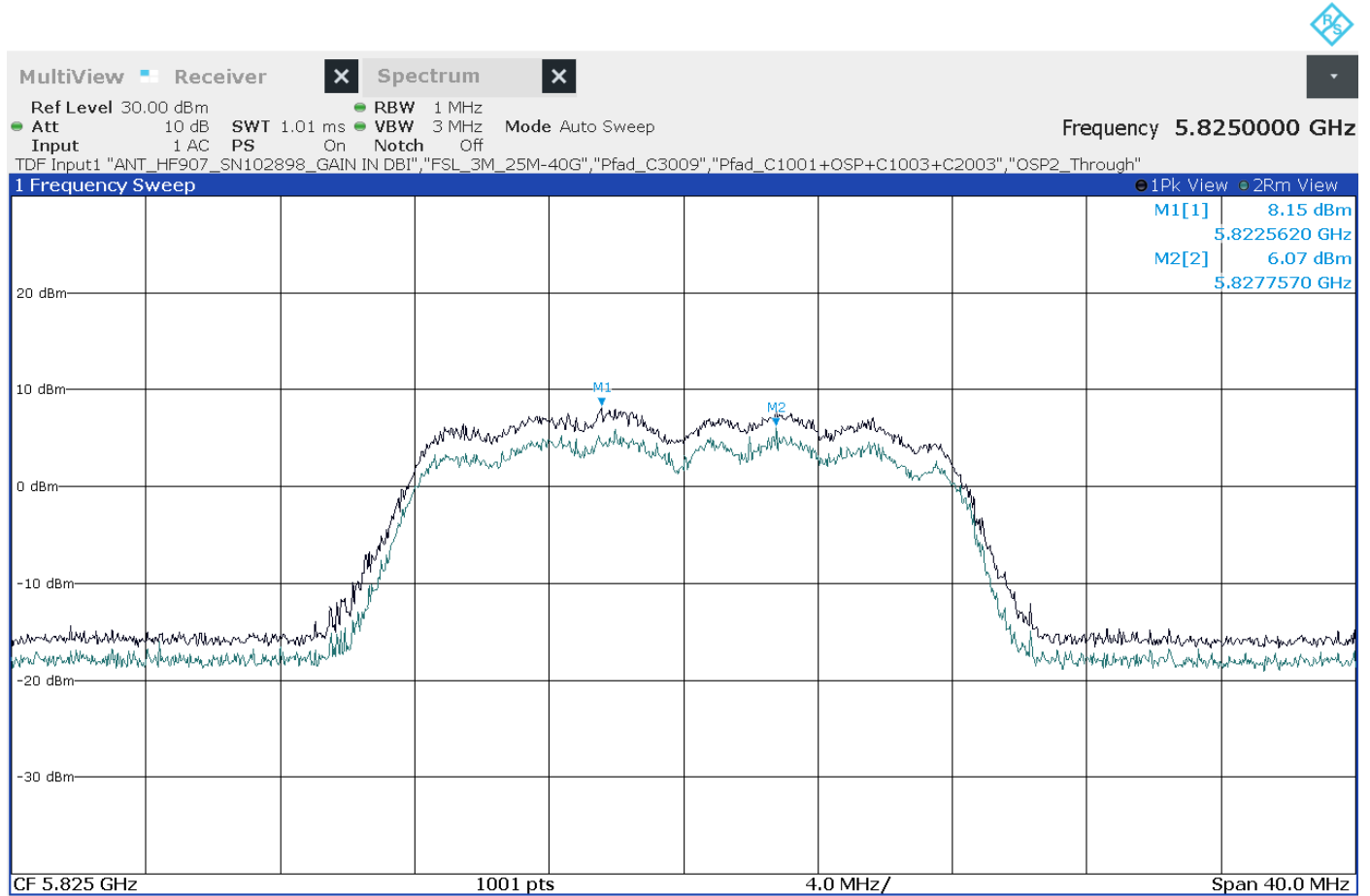

10:53:32 06/30/2023

## Band Edge Compliance (BEC)

### EUT No 79

23. Test: Band Edge Compliance (BEC), EUT No: 79, SN: R0091, Mode 1, a-mode, channel 36, 5180 MHz, 20 MHz channel bandwidth

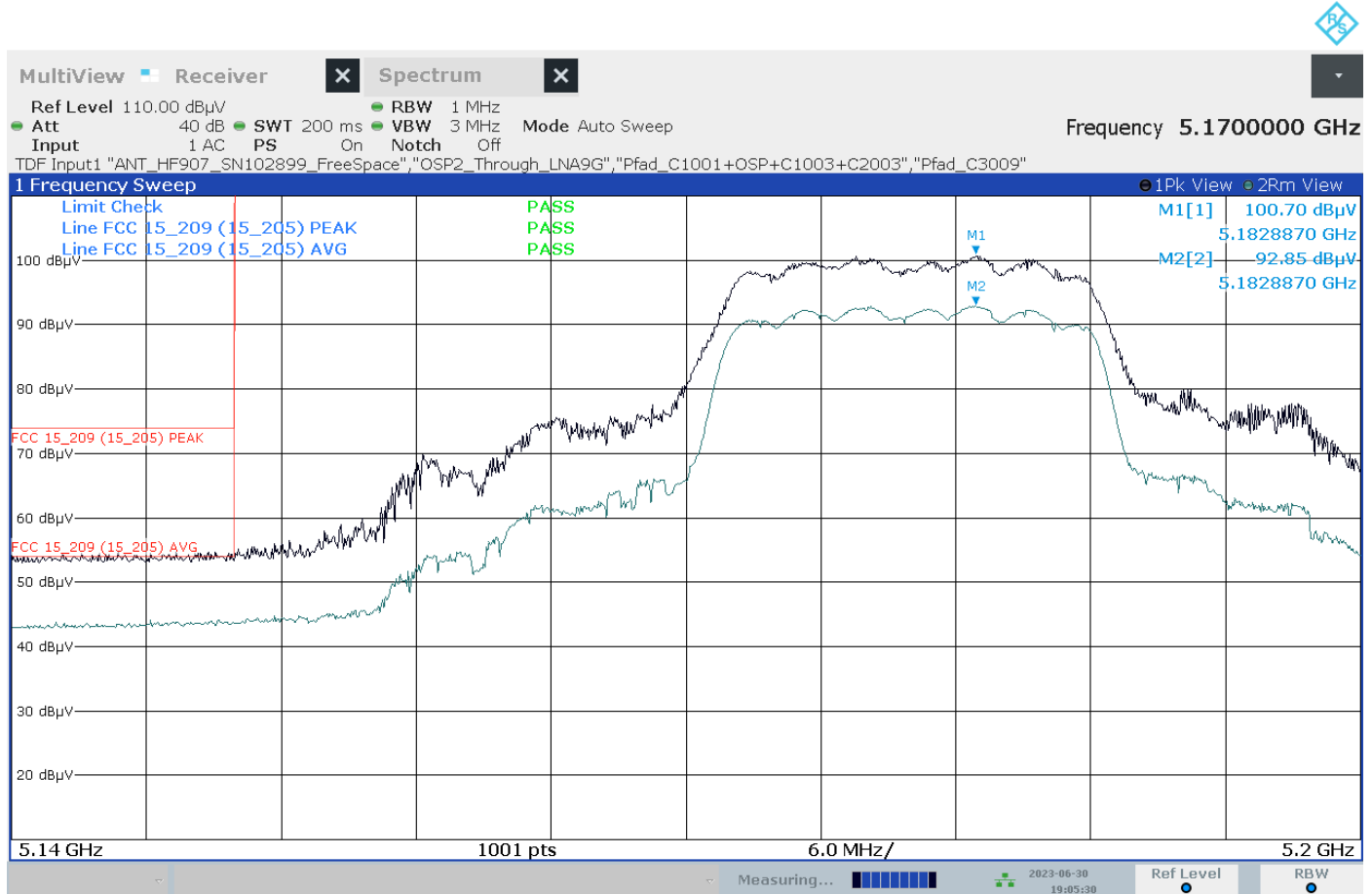

07:05:31 06/30/2023

Annex A of TR no.: 23038521-32374-0

24. Test: Band Edge Compliance (BEC), EUT No: 79, SN: R0091, Mode 6, n-HT40 mode, channel 38, 5190 MHz, 40 MHz channel bandwidth

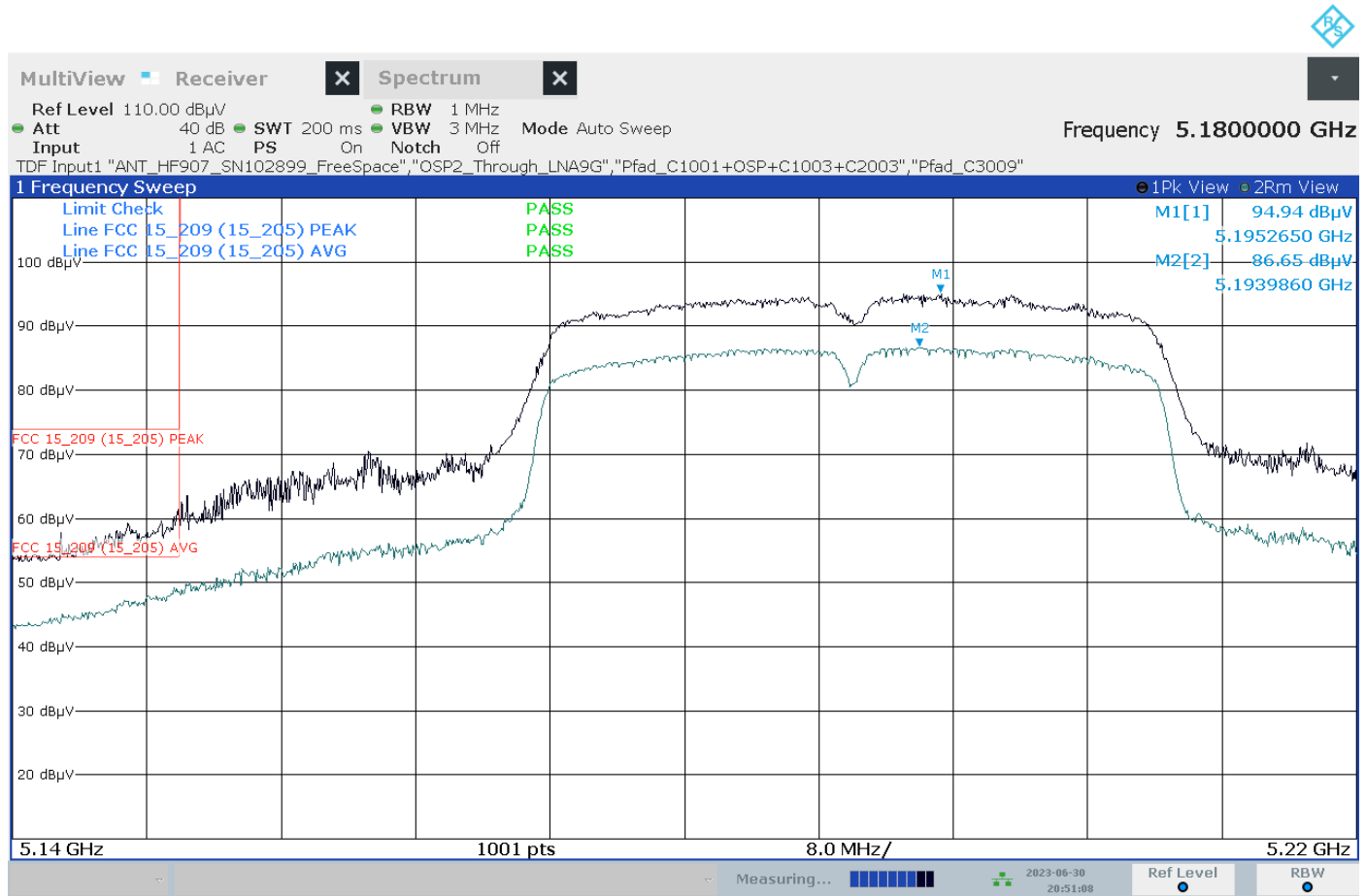

08:51:08 06/30/2023

Annex A of TR no.: 23038521-32374-0

25. Test: Band Edge Compliance (BEC), EUT No: 79, SN: R0091, Mode 6, ac-HT80 mode, channel 42, 5210 MHz, 80 MHz channel bandwidth



09:15:54 06/30/2023

Annex A of TR no.: 23038521-32374-0

26. Test: Band Edge Compliance (BEC), EUT No: 79, SN: R0091, Mode 6, ac-HT80 mode, channel 58, 5290 MHz, 80 MHz channel bandwidth

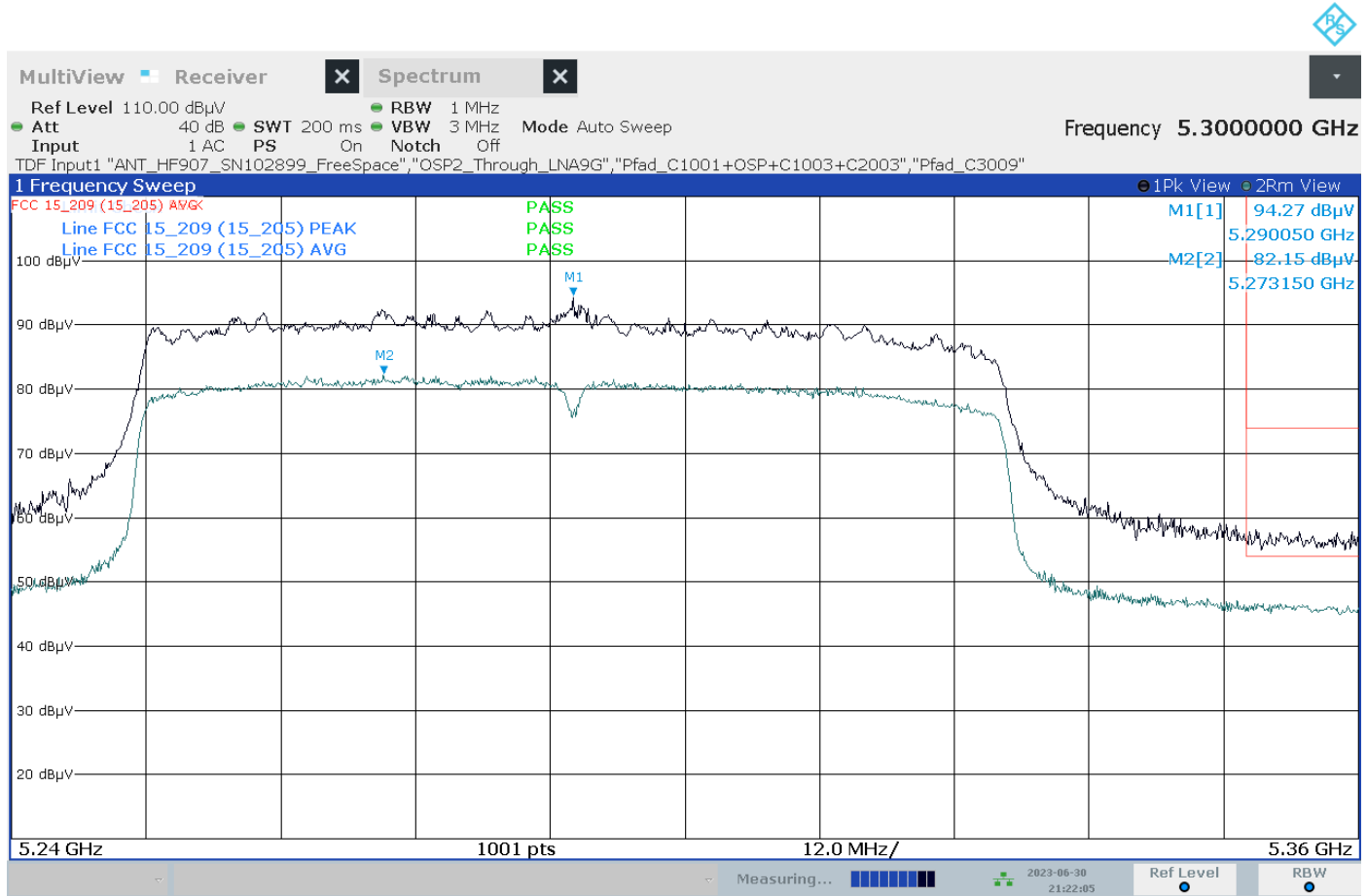

09:22:05 06/30/2023

Annex A of TR no.: 23038521-32374-0

27. Test: Band Edge Compliance (BEC), EUT No: 79, SN: R0091, Mode 2, n-HT40 mode, channel 62, 5310 MHz, 40 MHz channel bandwidth

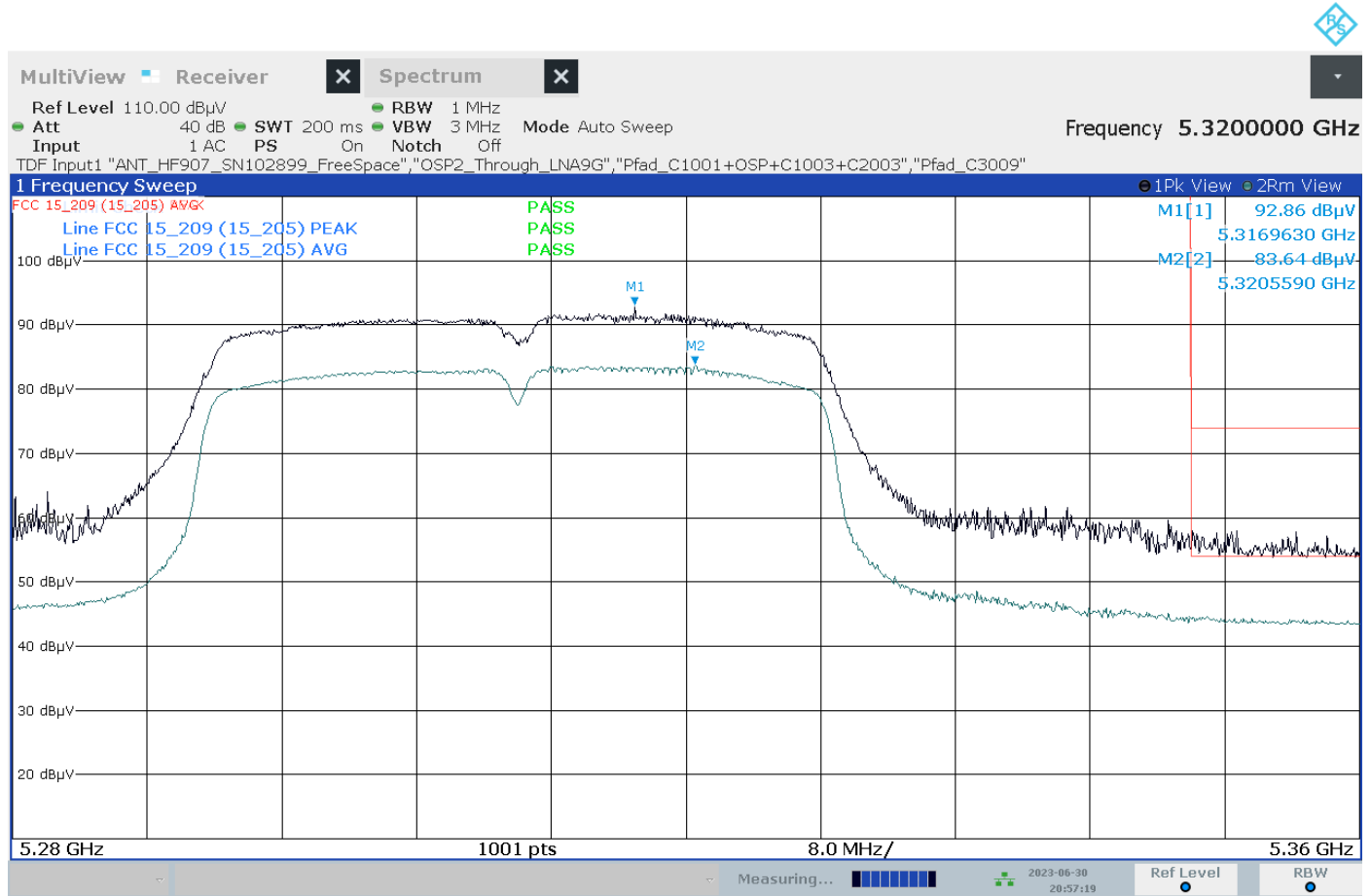

08:57:20 06/30/2023

Annex A of TR no.: 23038521-32374-0

28. Test: Band Edge Compliance (BEC), EUT No: 79, SN: R0091, Mode 1, a-mode, channel 64, 5320 MHz, 20 MHz channel bandwidth

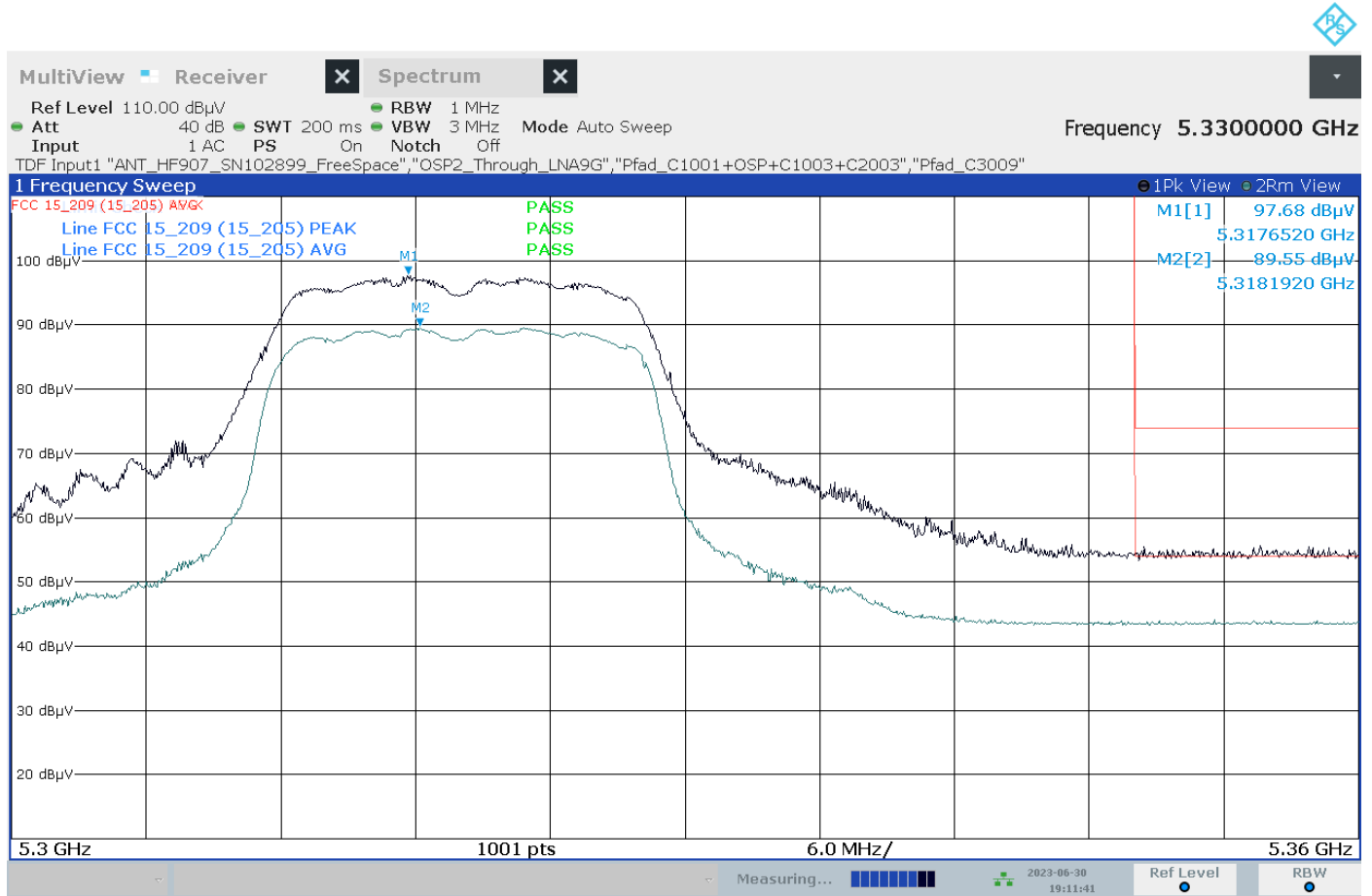

07:11:42 06/30/2023



Annex A of TR no.: 23038521-32374-0

29. Test: Band Edge Compliance (BEC), EUT No: 79, SN: R0091, Mode 1, a-mode, channel 100, 5500 MHz, 20 MHz channel bandwidth

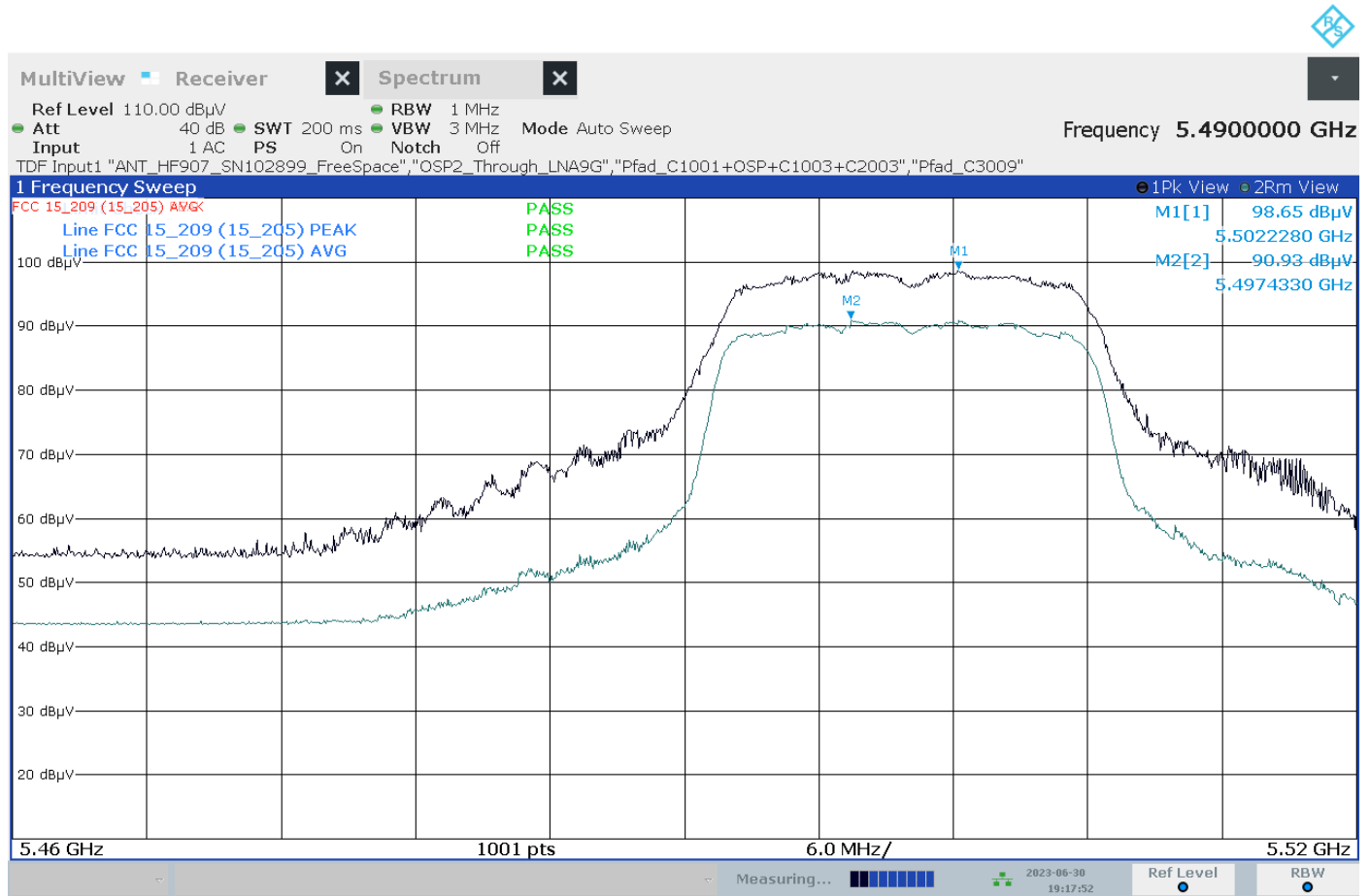

07:17:53 06/30/2023

Annex A of TR no.: 23038521-32374-0

30. Test: Band Edge Compliance (BEC), EUT No: 79, SN: R0091, Mode 2, n-HT40 mode, channel 102, 5510 MHz, 40 MHz channel bandwidth

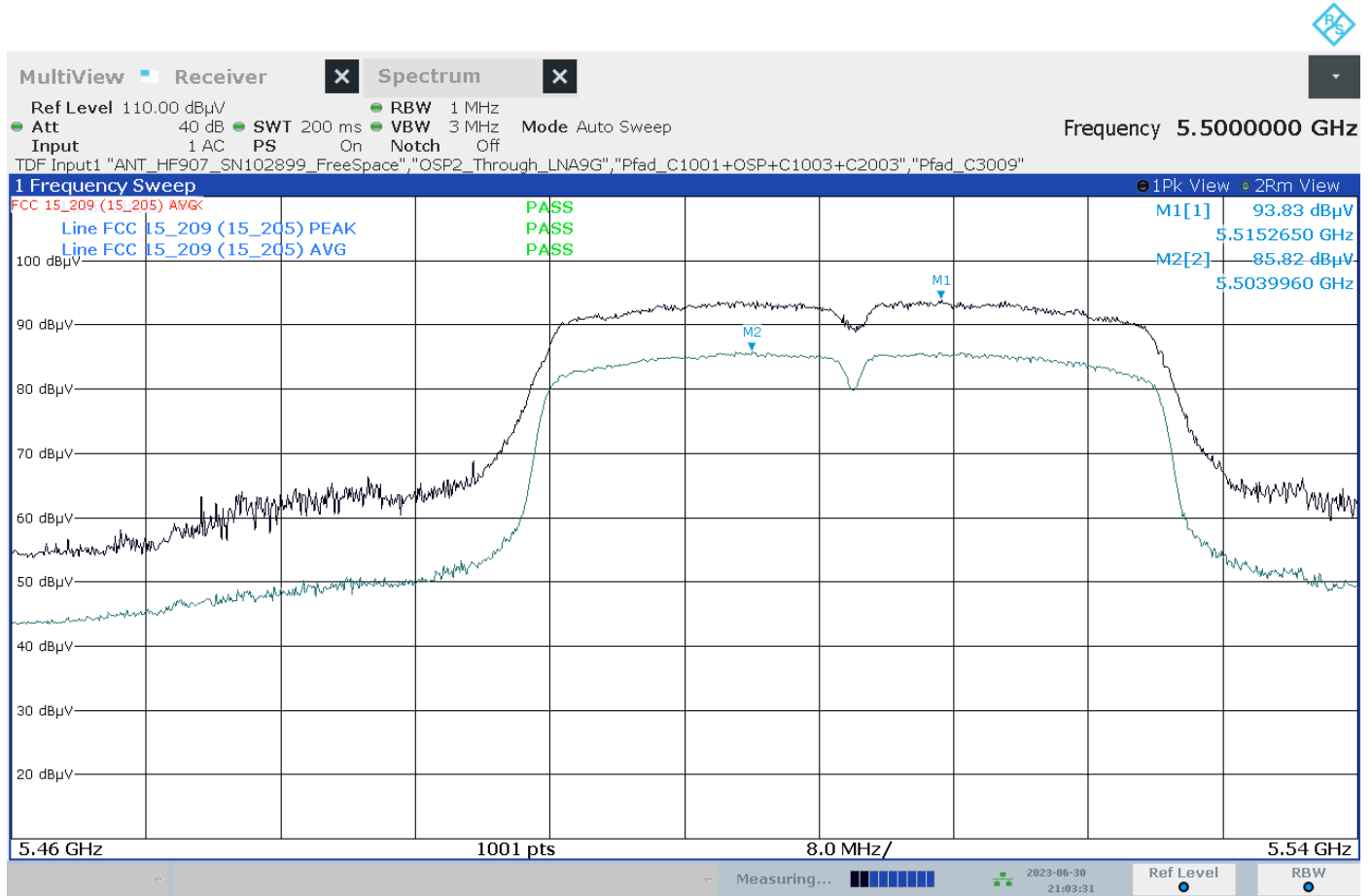

09:03:31 06/30/2023

Annex A of TR no.: 23038521-32374-0

31. Test: Band Edge Compliance (BEC), EUT No: 79, SN: R0091, Mode 6, ac-HT80 mode, channel 106, 5530 MHz, 80 MHz channel bandwidth

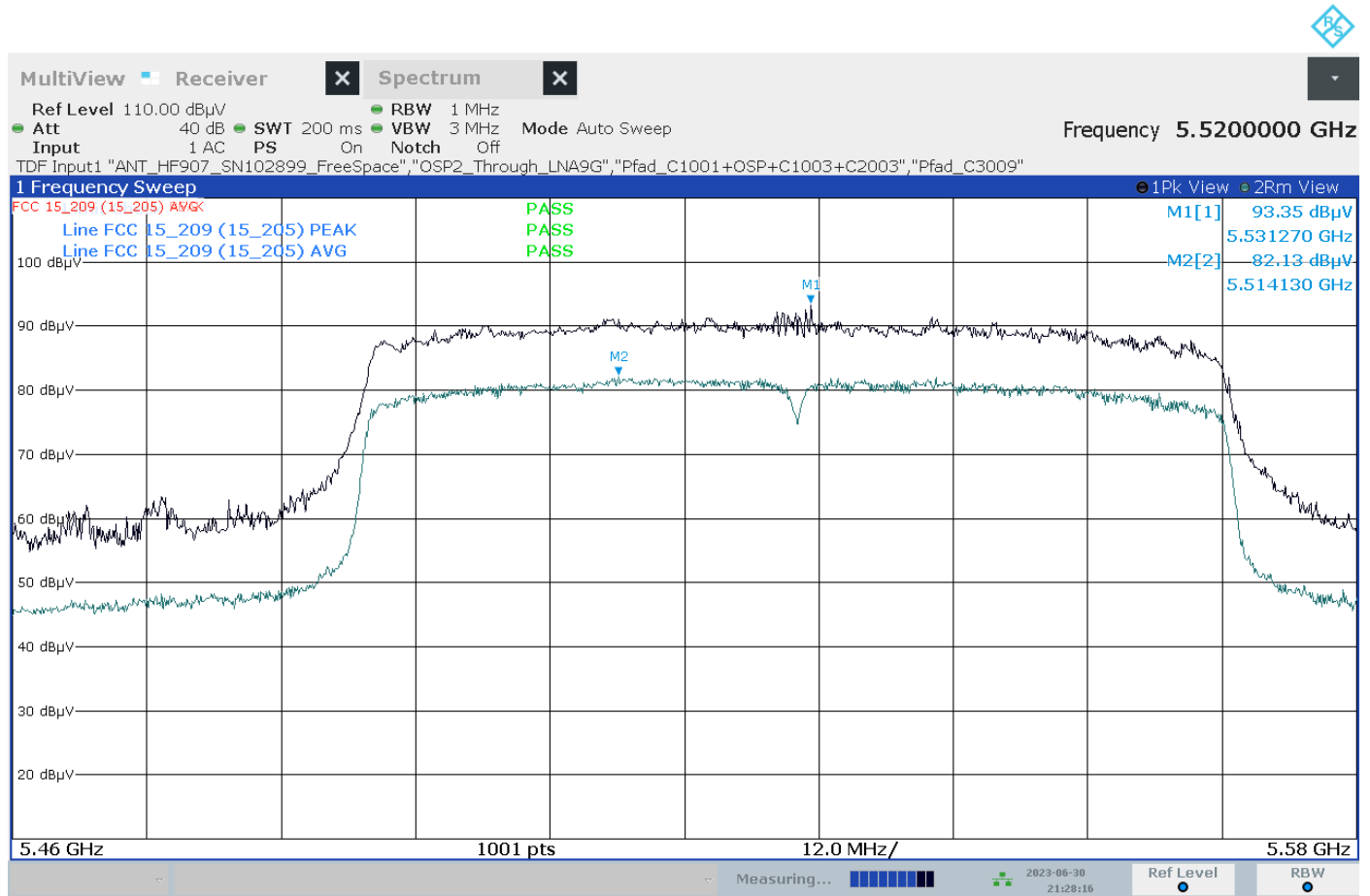

09:28:17 06/30/2023

Annex A of TR no.: 23038521-32374-0

32. Test: Band Edge Compliance (BEC), EUT No: 79, SN: R0091, Mode 6, ac-HT80 mode, channel 155, 5775 MHz, 80 MHz channel bandwidth

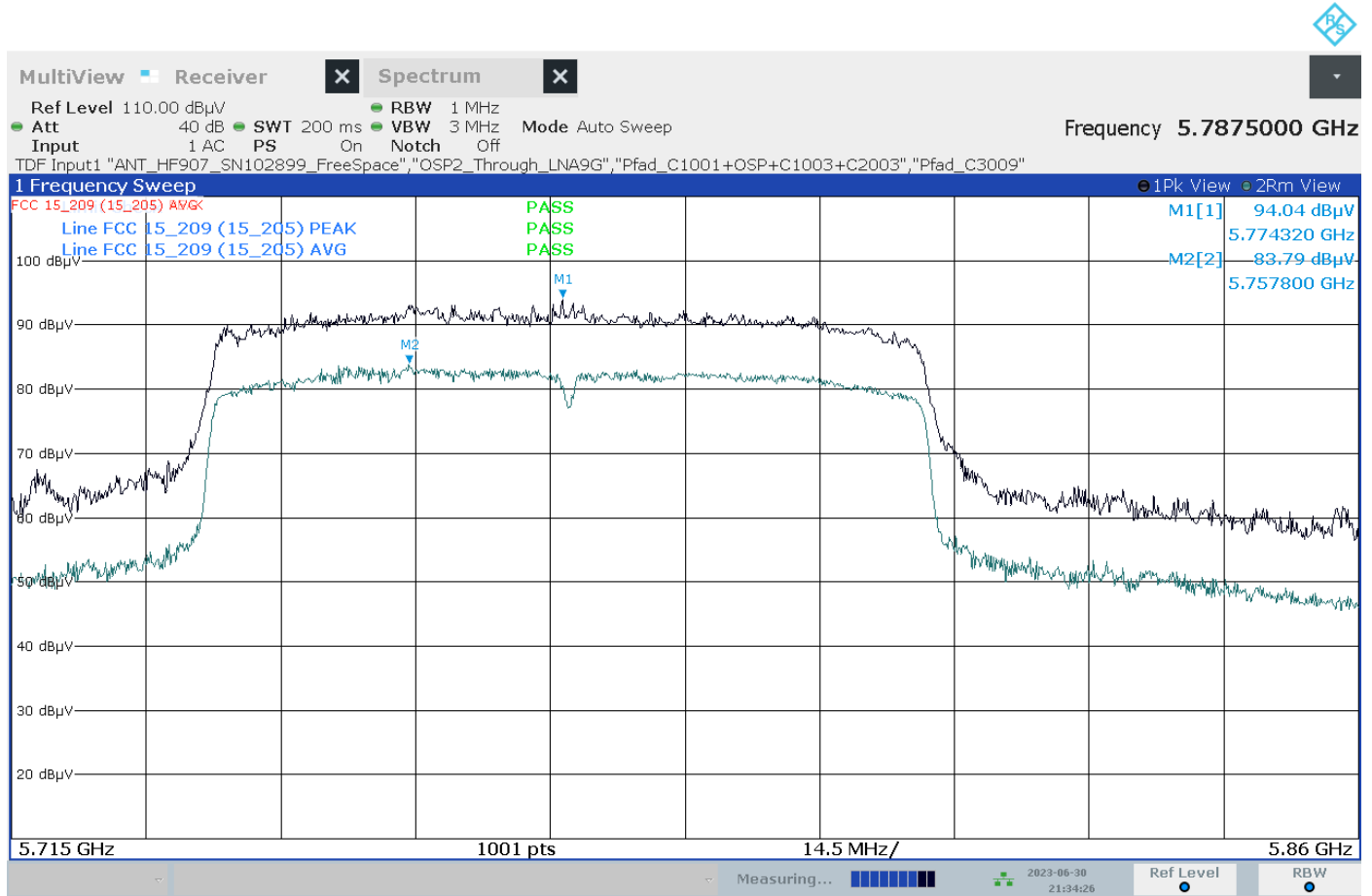

09:34:27 06/30/2023

Annex A of TR no.: 23038521-32374-0

33. Test: Band Edge Compliance (BEC), EUT No: 79, SN: R0091, Mode 2, n-HT40 mode, channel 159, 5795 MHz, 40 MHz channel bandwidth



09:09:41 06/30/2023

Annex A of TR no.: 23038521-32374-0

34. Test: Band Edge Compliance (BEC), EUT No: 79, SN: R0091, Mode 1, a-mode, channel 165, 5825 MHz, 20 MHz channel bandwidth

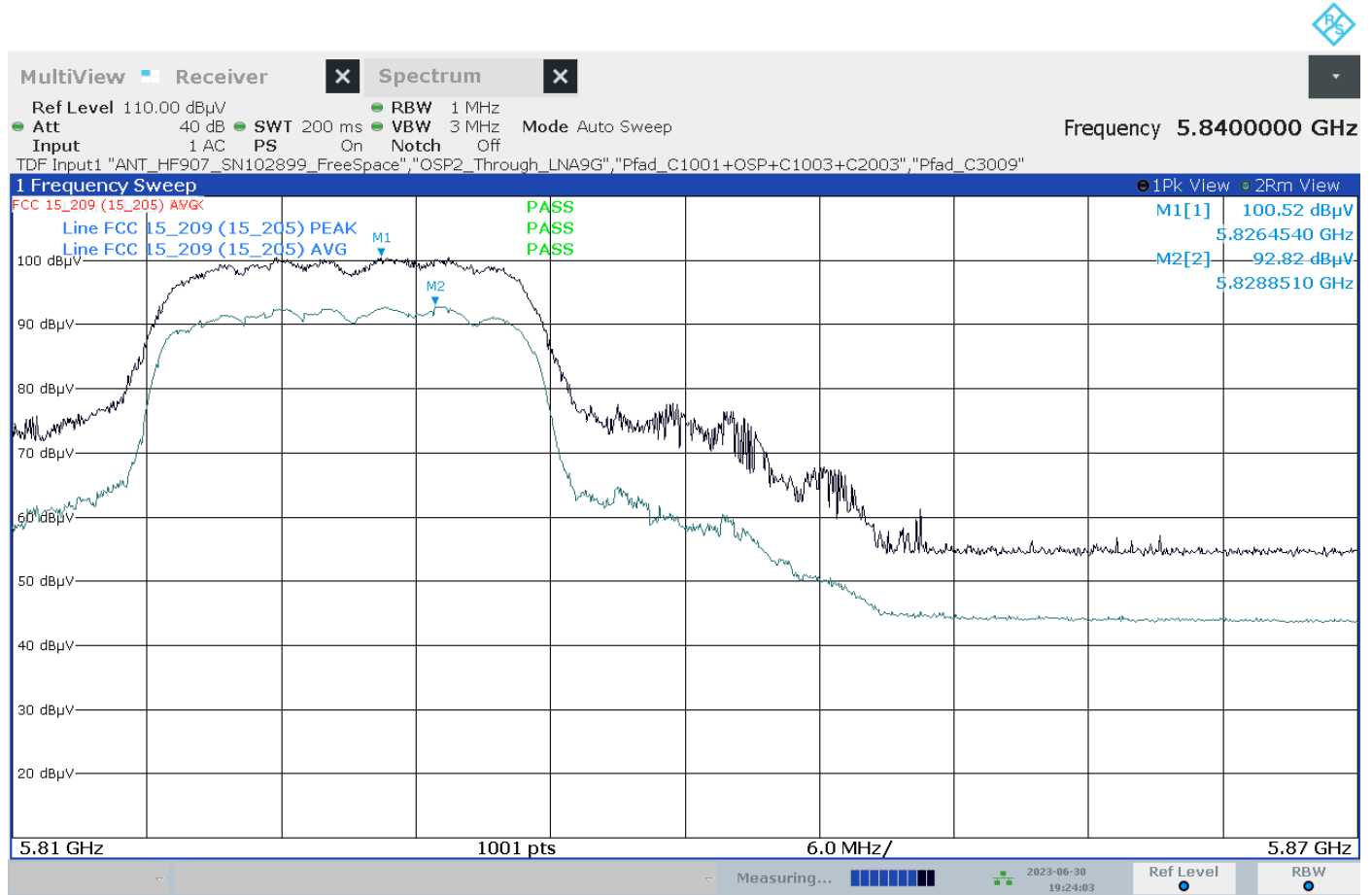

07:24:04 06/30/2023

Annex A of TR no.: 23038521-32374-0

### EUT No 80

35. Test: Band Edge Compliance (BEC), EUT No: 80, SN: R0047, Mode 1, a-mode, channel 36, 5180 MHz, 20 MHz channel bandwidth

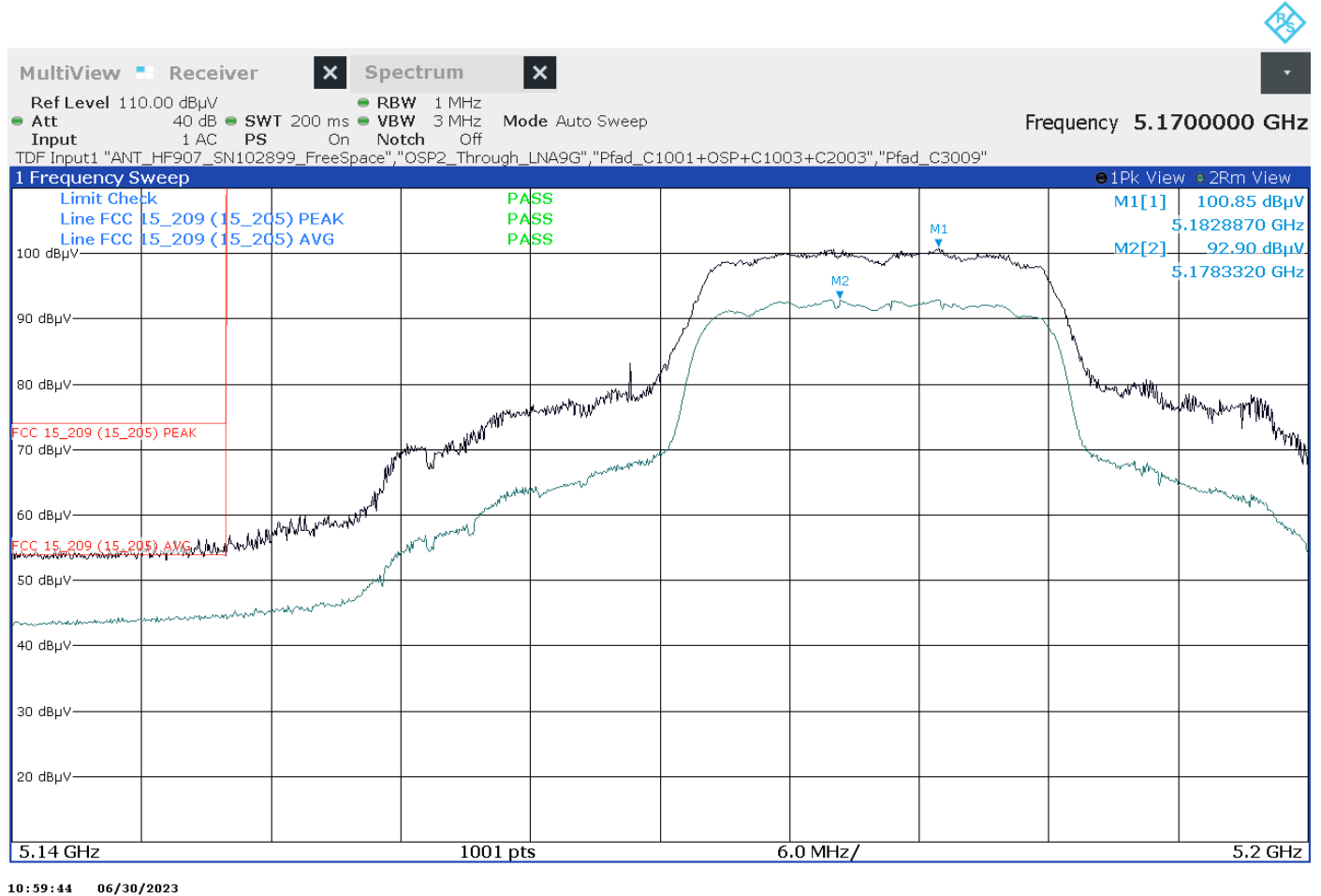

Annex A of TR no.: 23038521-32374-0

36. Test: Band Edge Compliance (BEC), EUT No: 80, SN: R0047, Mode 2, n-HT40 mode, channel 38, 5190 MHz, 40 MHz channel bandwidth

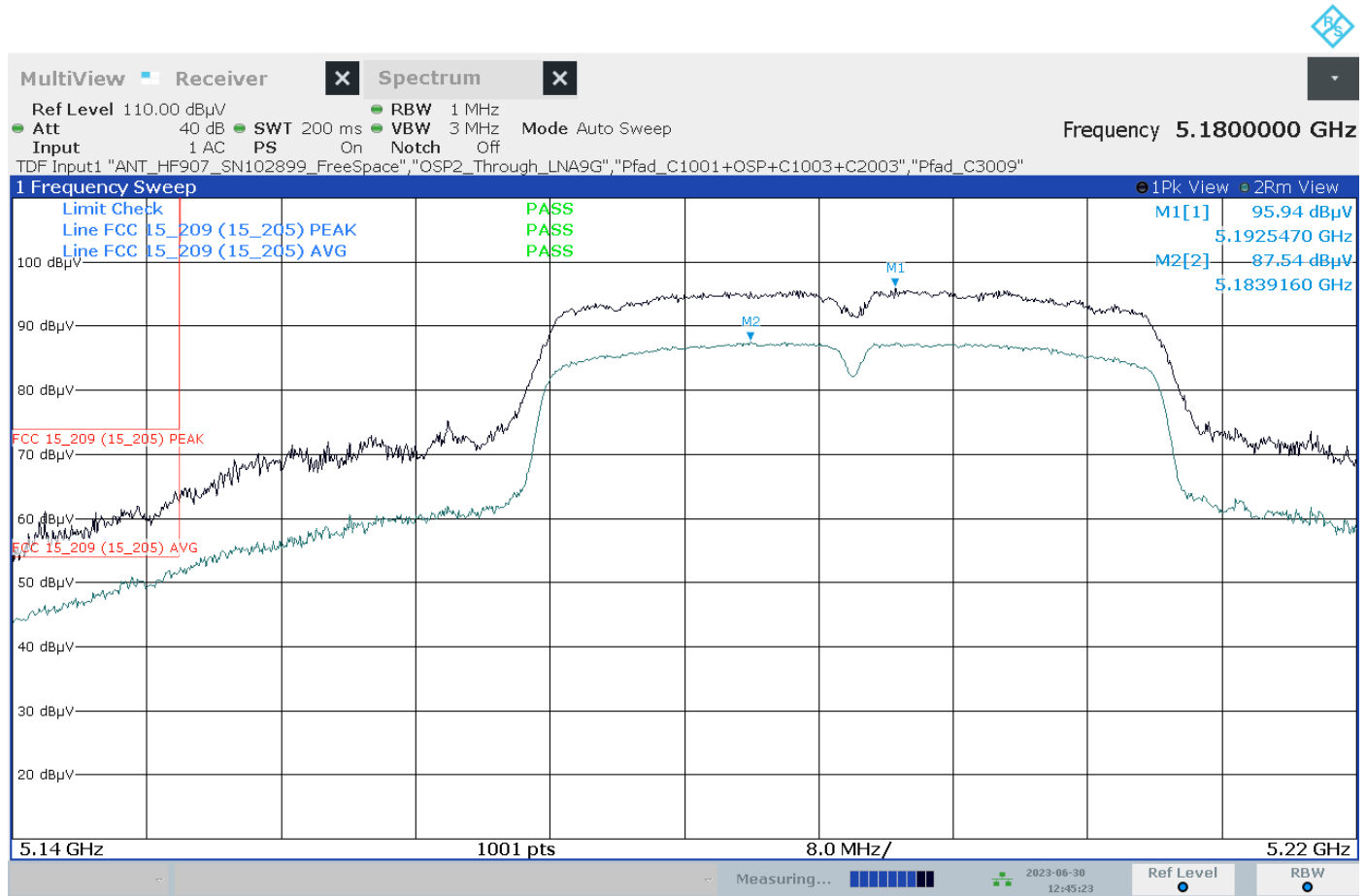

12:45:24 06/30/2023



Annex A of TR no.: 23038521-32374-0

37. Test: Band Edge Compliance (BEC), EUT No: 80, SN: R0047, Mode 6, ac-HT80 mode, channel 42, 5210 MHz, 80 MHz channel bandwidth

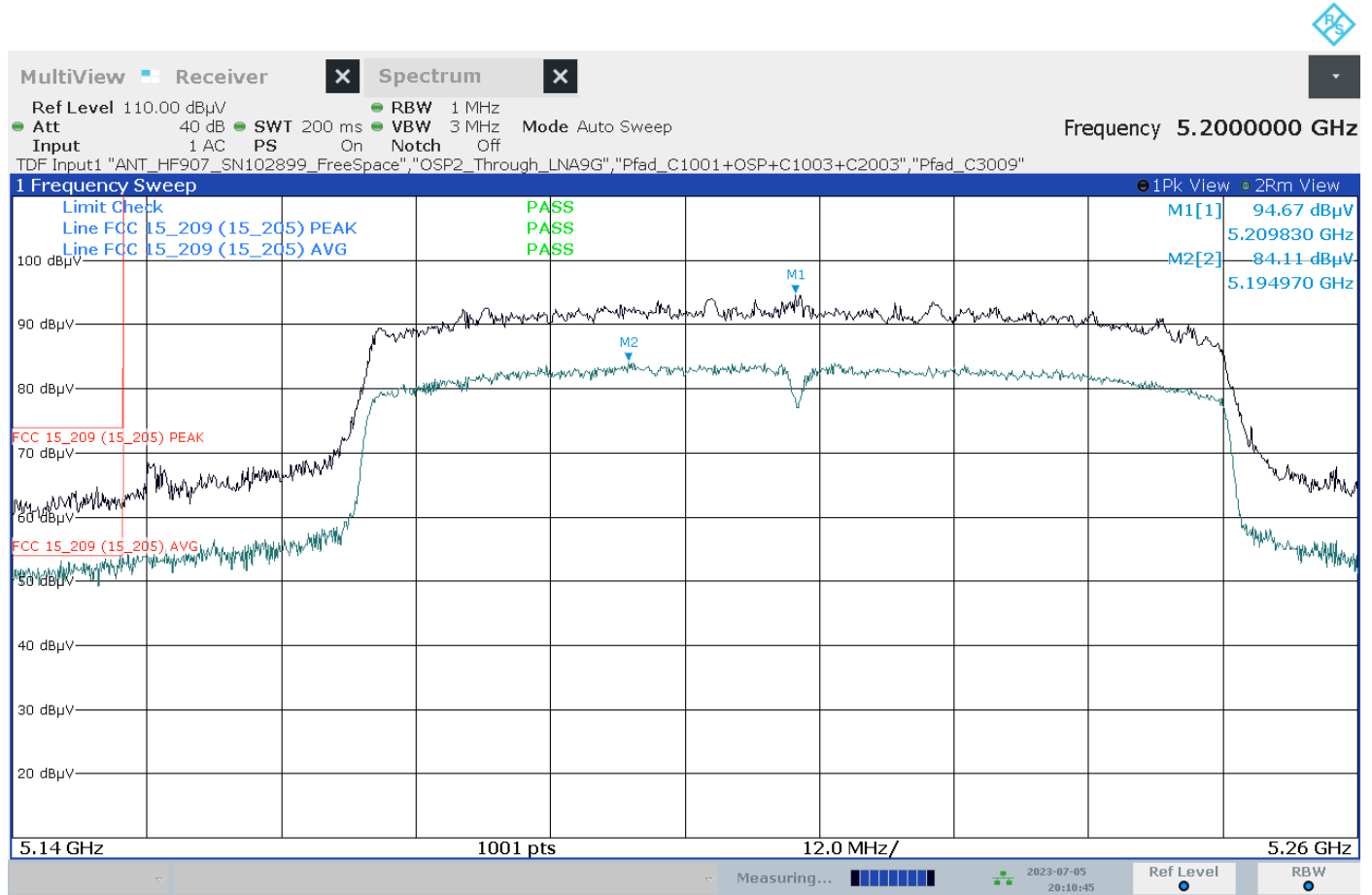

08:10:46 07/05/2023

Annex A of TR no.: 23038521-32374-0

38. Test: Band Edge Compliance (BEC), EUT No: 80, SN: R0047, Mode 6, ac-HT80 mode, channel 58, 5290 MHz, 80 MHz channel bandwidth

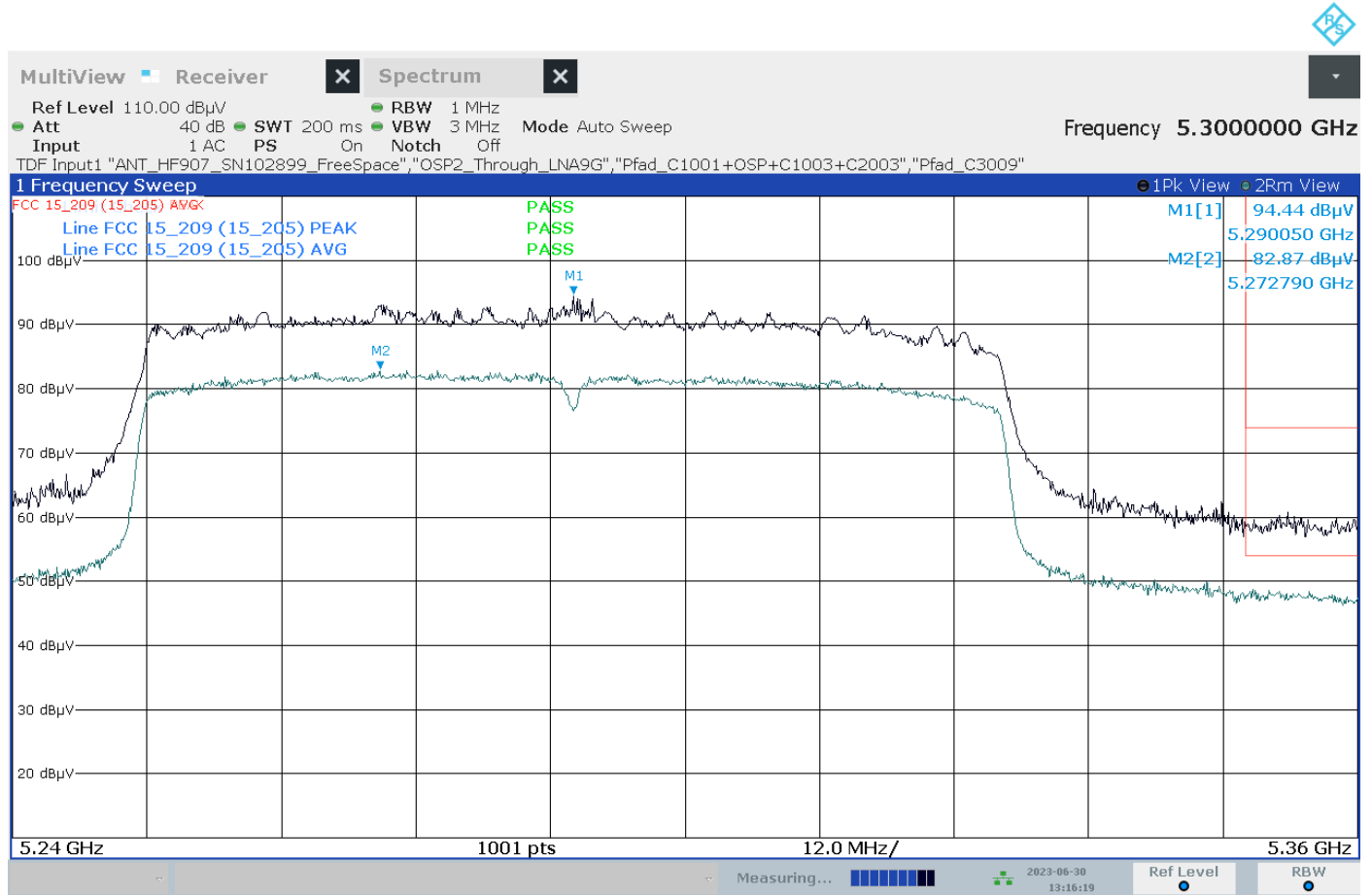

01:16:20 06/30/2023

Annex A of TR no.: 23038521-32374-0

39. Test: Band Edge Compliance (BEC), EUT No: 80, SN: R0047, Mode 2, n-HT40 mode, channel 62, 5310 MHz, 40 MHz channel bandwidth

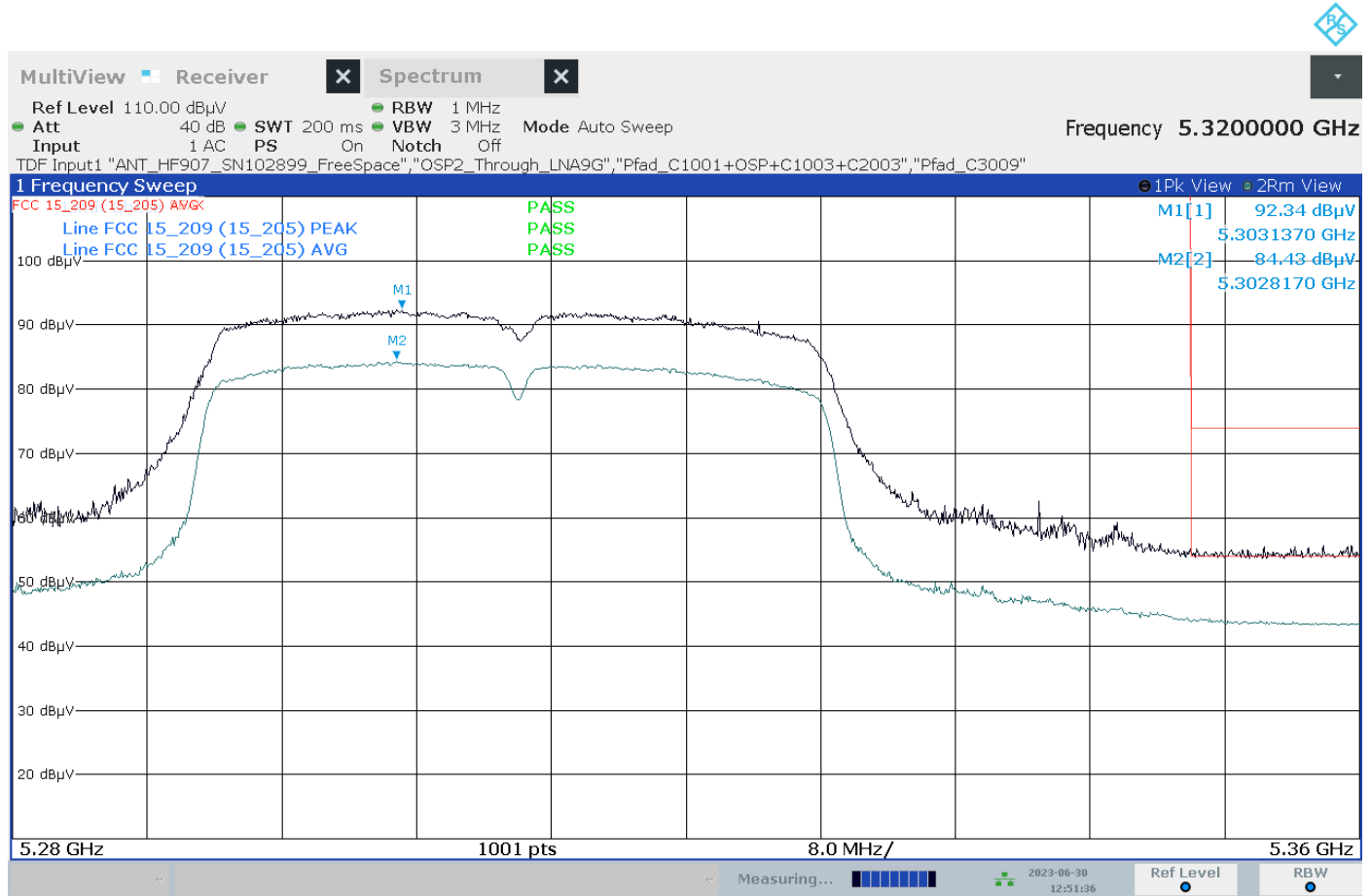

12:51:36 06/30/2023

Annex A of TR no.: 23038521-32374-0

40. Test: Band Edge Compliance (BEC), EUT No: 80, SN: R0047, Mode 1, a-mode, channel 64, 5320 MHz, 20 MHz channel bandwidth

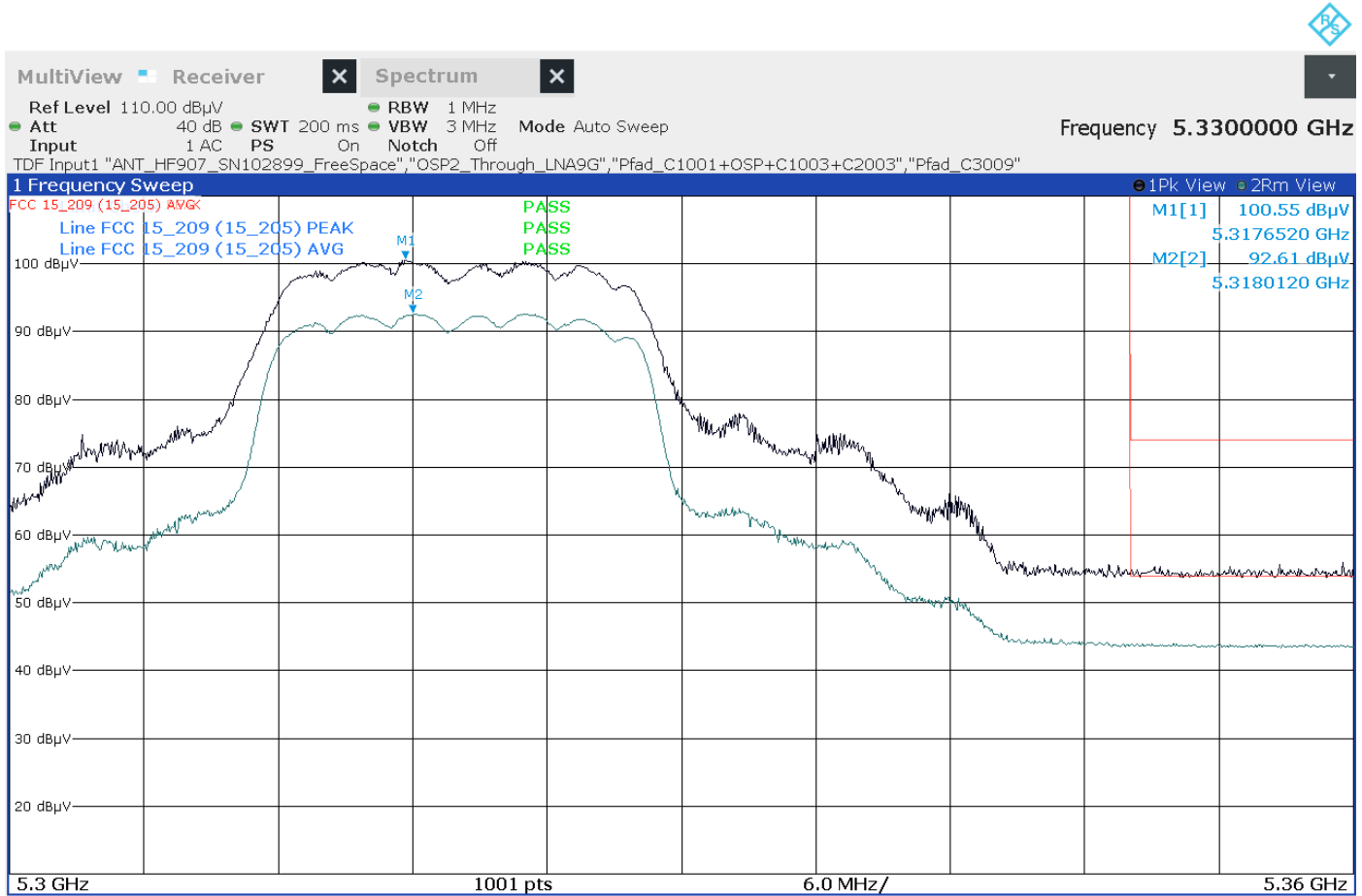

11:05:54 06/30/2023

Annex A of TR no.: 23038521-32374-0

41. Test: Band Edge Compliance (BEC), EUT No: 80, SN: R0047, Mode 1, a-mode, channel 100, 5500 MHz, 20 MHz channel bandwidth

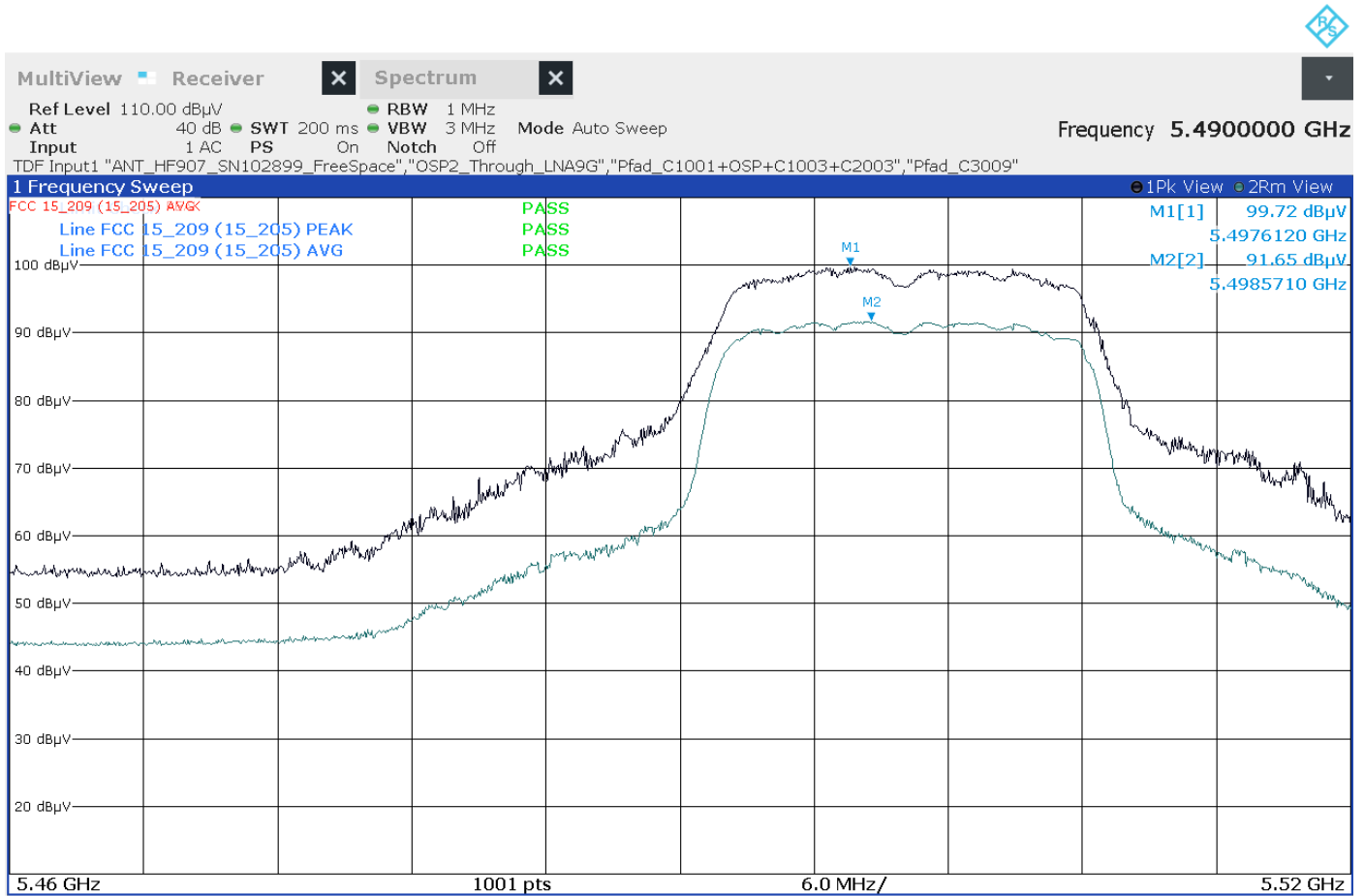

11:12:05 06/30/2023

Annex A of TR no.: 23038521-32374-0

42. Test: Band Edge Compliance (BEC), EUT No: 80, SN: R0047, Mode 2, n-HT40 mode, channel 102, 5510 MHz, 40 MHz channel bandwidth

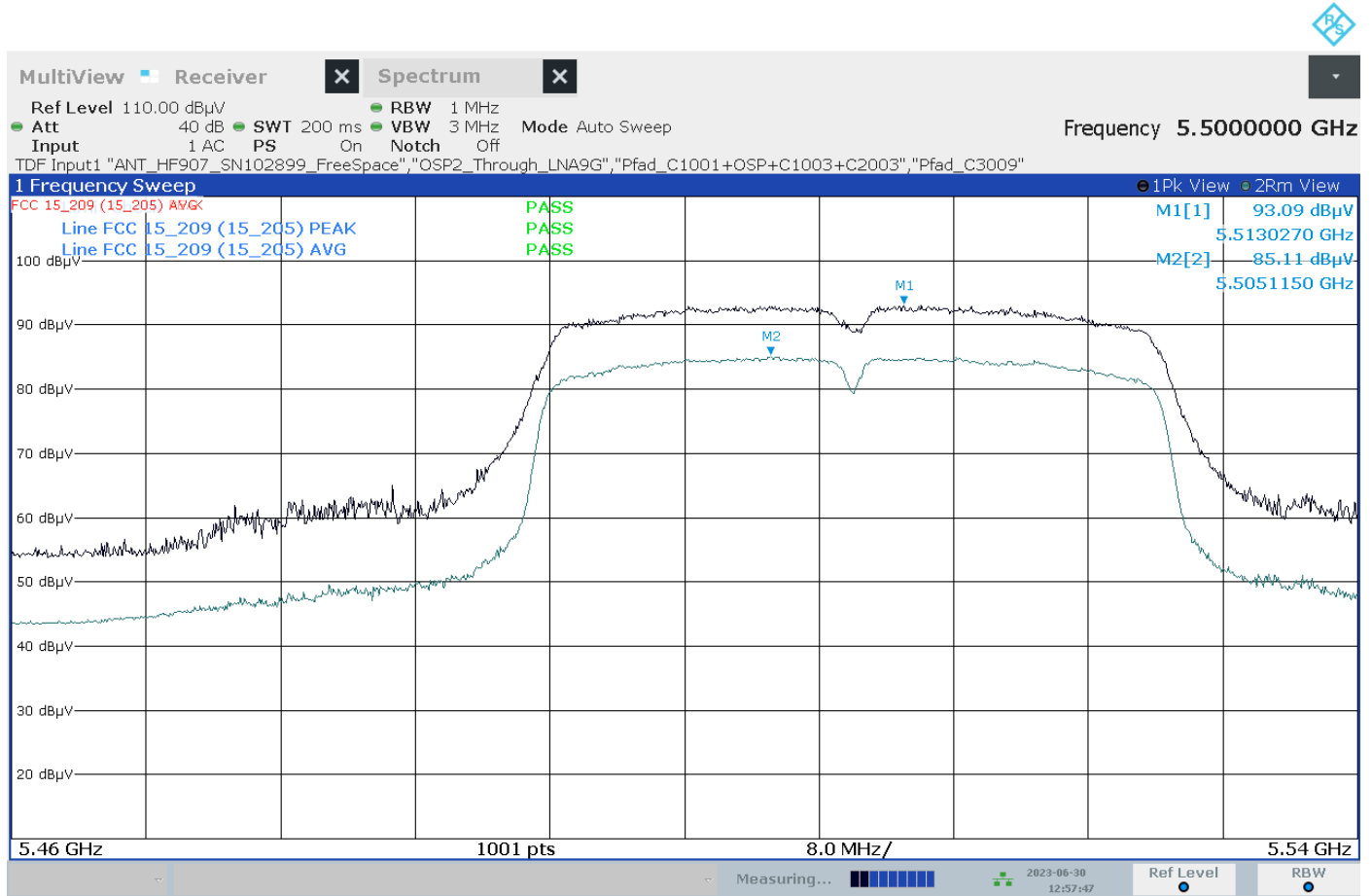

12:57:47 06/30/2023

Annex A of TR no.: 23038521-32374-0

43. Test: Band Edge Compliance (BEC), EUT No: 80, SN: R0047, Mode 6, ac-HT80 mode, channel 106, 5530 MHz, 80 MHz channel bandwidth

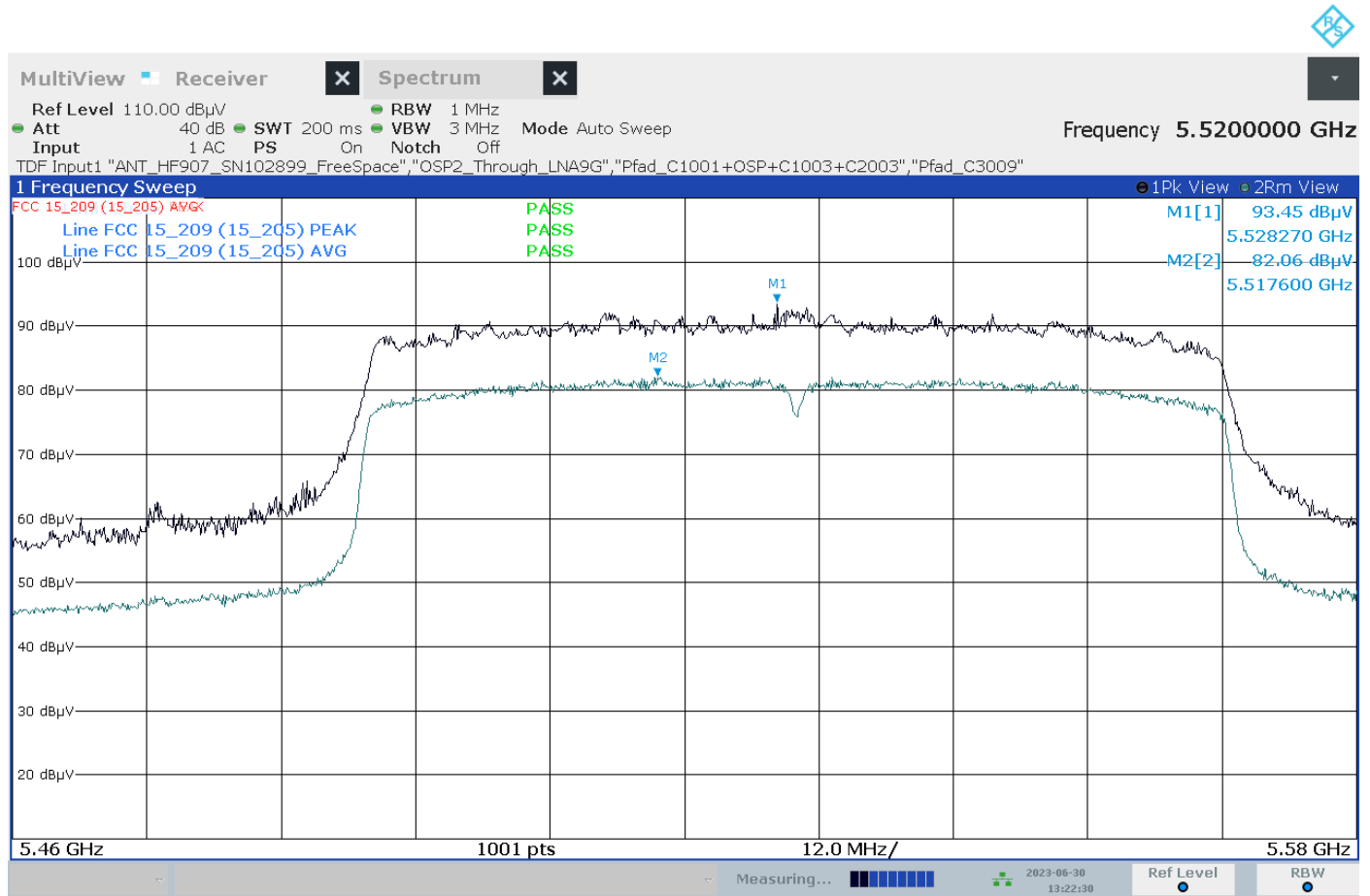

01:22:31 06/30/2023

Annex A of TR no.: 23038521-32374-0

44. Test: Band Edge Compliance (BEC), EUT No: 80, SN: R0047, Mode 6, ac-HT80 mode, channel 155, 5775 MHz, 80 MHz channel bandwidth

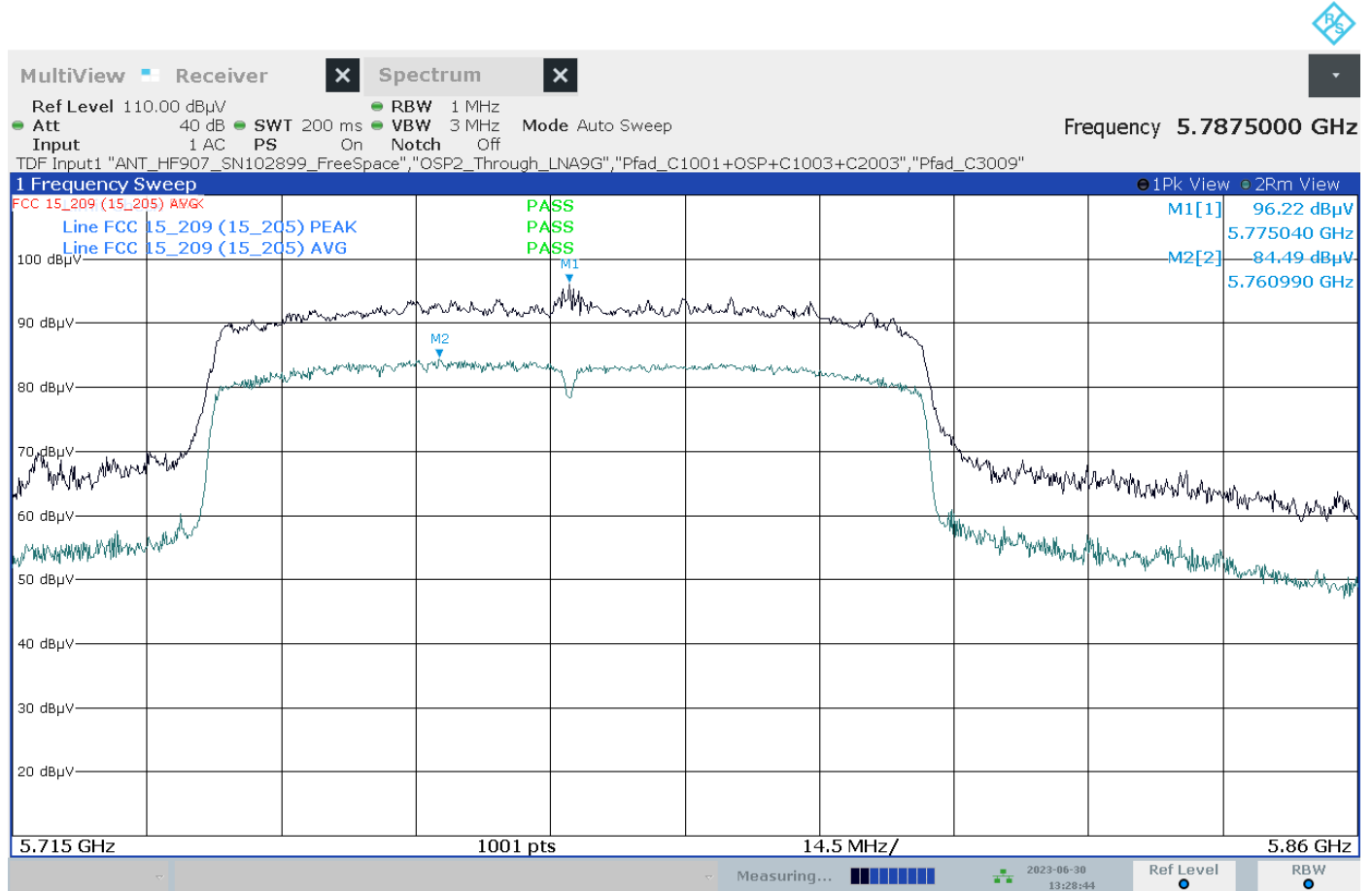

01:28:44 06/30/2023



Annex A of TR no.: 23038521-32374-0

45. Test: Band Edge Compliance (BEC), EUT No: 80, SN: R0047, Mode 2, n-HT40 mode, channel 159, 5795 MHz, 40 MHz channel bandwidth

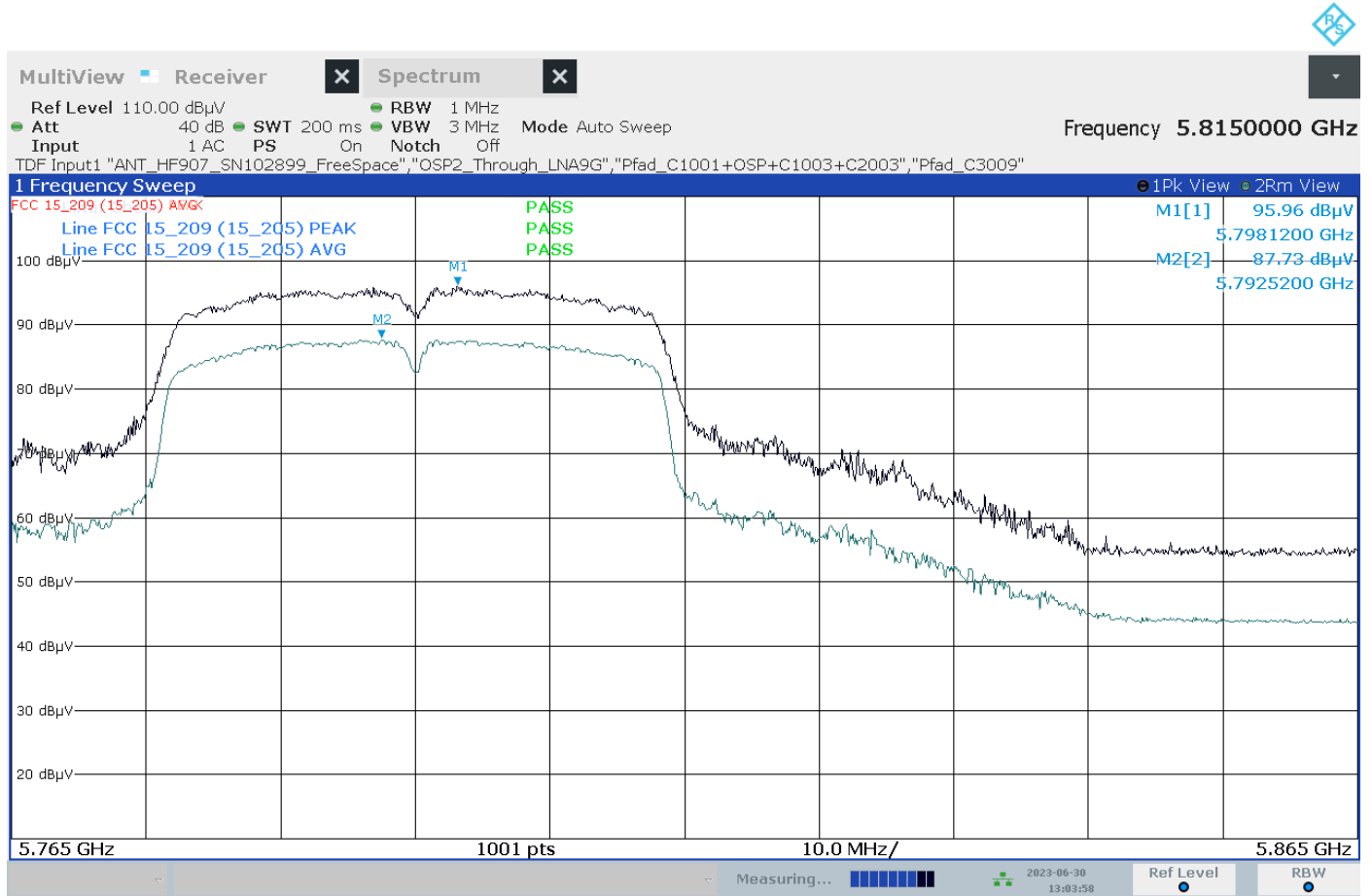

01:03:59 06/30/2023

Annex A of TR no.: 23038521-32374-0

46. Test: Band Edge Compliance (BEC), EUT No: 80, SN: R0047, Mode 1, a-mode, channel 165, 5825 MHz, 20 MHz channel bandwidth

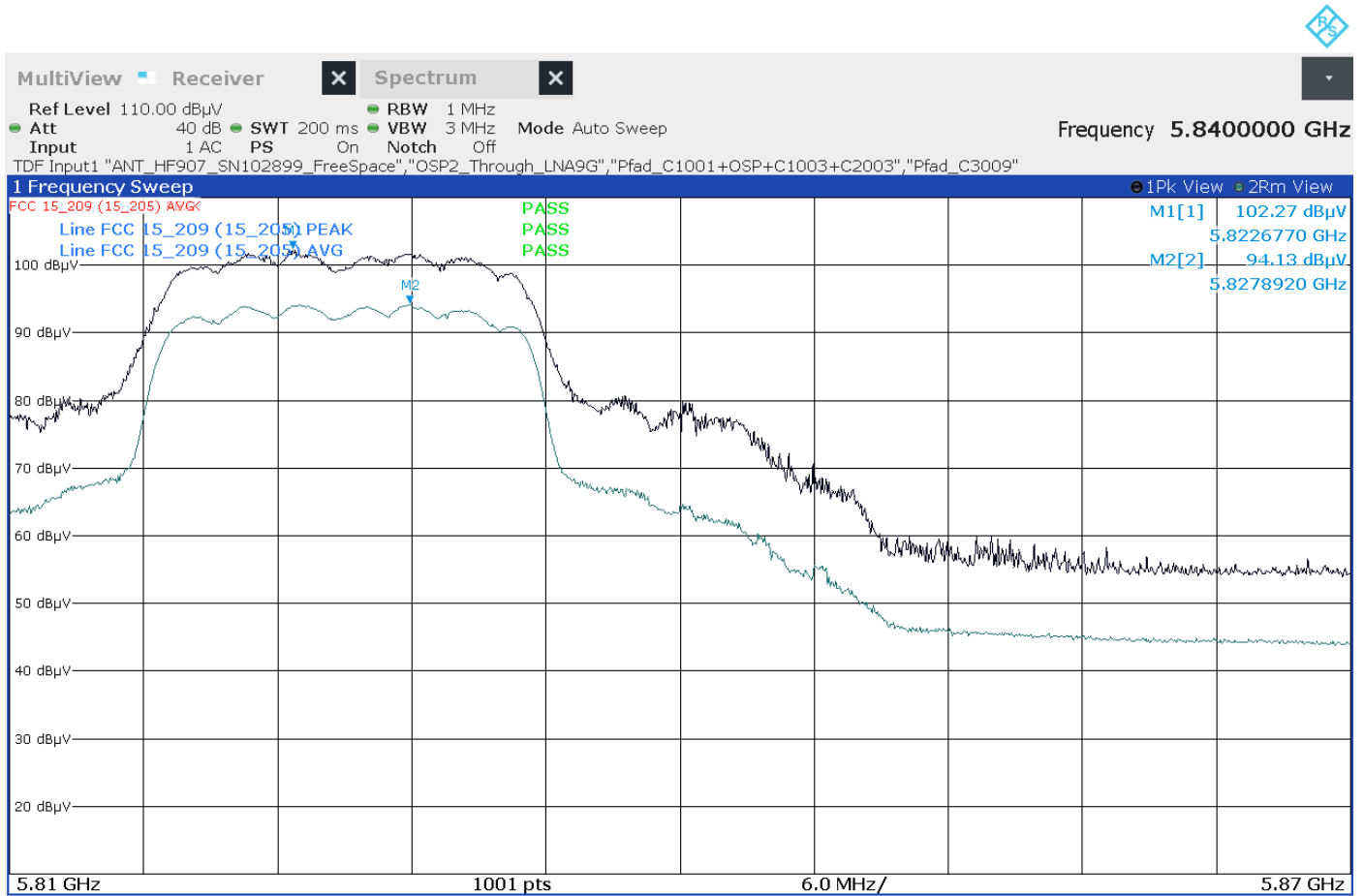

11:18:17 06/30/2023

## Radiated Spurious Emissions (RSE)

### EUT No 79

47. Test: RSE 9 kHz - 30 MHz, EUT No: 79, SN: R0091, Mode 1, a-mode, channel 36, 5180 MHz, 20 MHz channel bandwidth

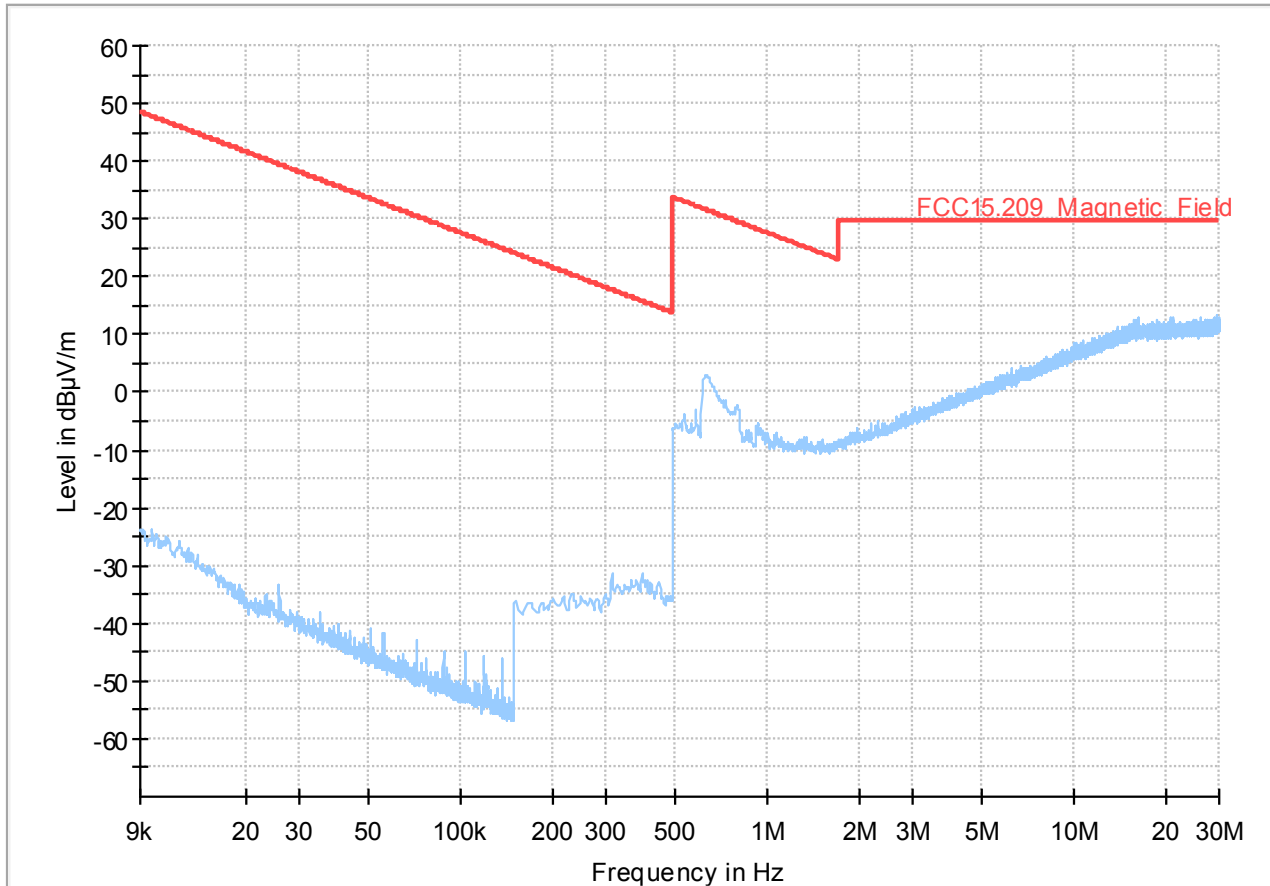

— Preview Result 1-PK+      \* Critical\_Freqs PK+  
— FCC15.209\_Magnetic\_Field      ◆ Final\_Result QPK

Annex A of TR no.: 23038521-32374-0

48. Test: RSE 30 MHz - 1 GHz, EUT No: 79, SN: R0091, Mode 1, a-mode, channel 36, 5180 MHz, 20 MHz channel bandwidth

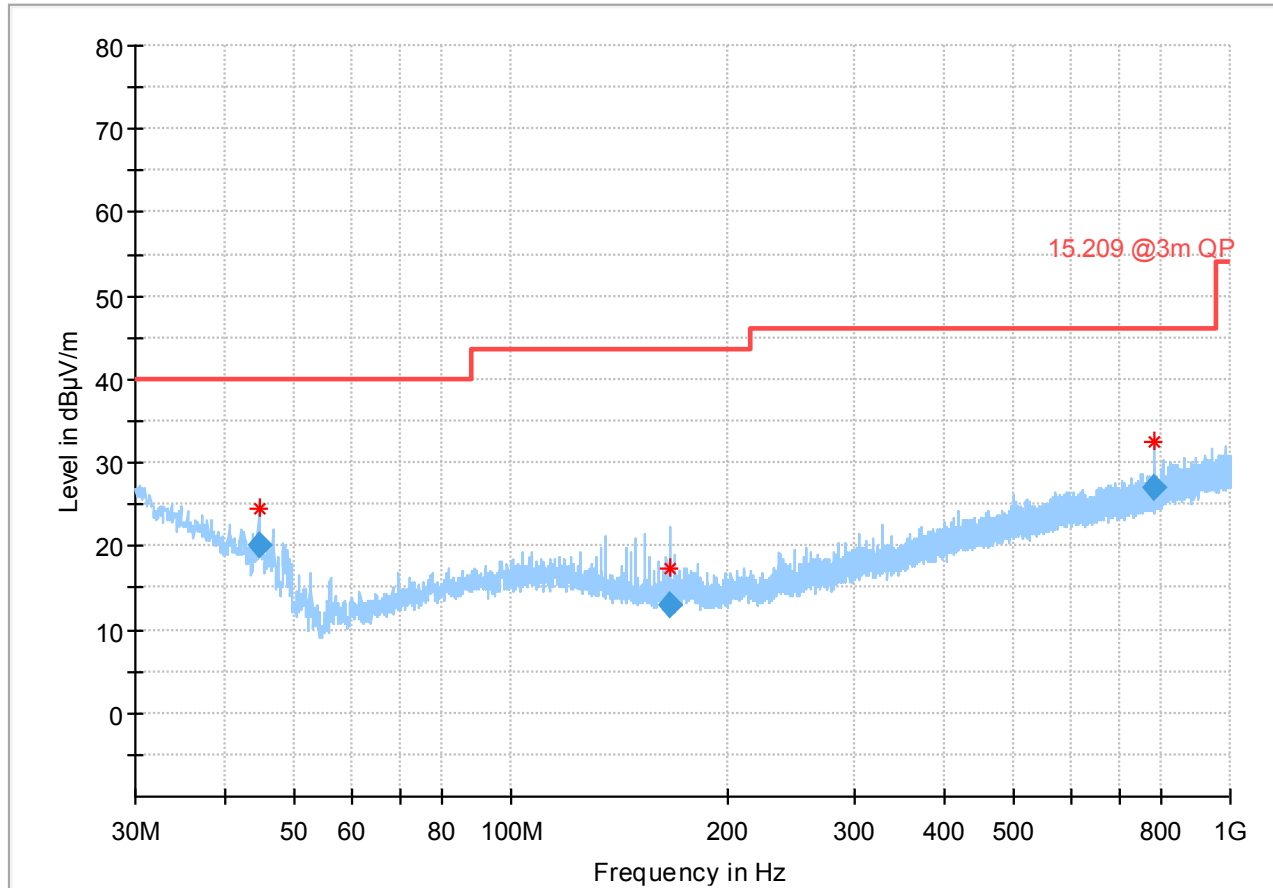

— Preview Result 1-PK+      \* Critical\_Freqs PK+  
— 15.209 @3m QP              ◆ Final\_Result QPK

Frequency (MHz)	QuasiPeak (dBµV/m)	Limit (dBµV/m)	Margin (dB)	Meas. Time (ms)	Bandwidth (kHz)	Height (cm)	Pol	Azimuth (deg)
44.600000	20.22	40.00	19.78	100.0	120.000	153.0	V	146.0
166.673000	13.01	43.50	30.49	100.0	120.000	150.0	V	134.0
784.733500	26.96	46.00	19.04	100.0	120.000	150.0	V	170.0

Annex A of TR no.: 23038521-32374-0

49. Test: RSE 9 kHz - 30 MHz, EUT No: 79, SN: R0091, Mode 1, a-mode, channel 64, 5320 MHz, 20 MHz channel bandwidth

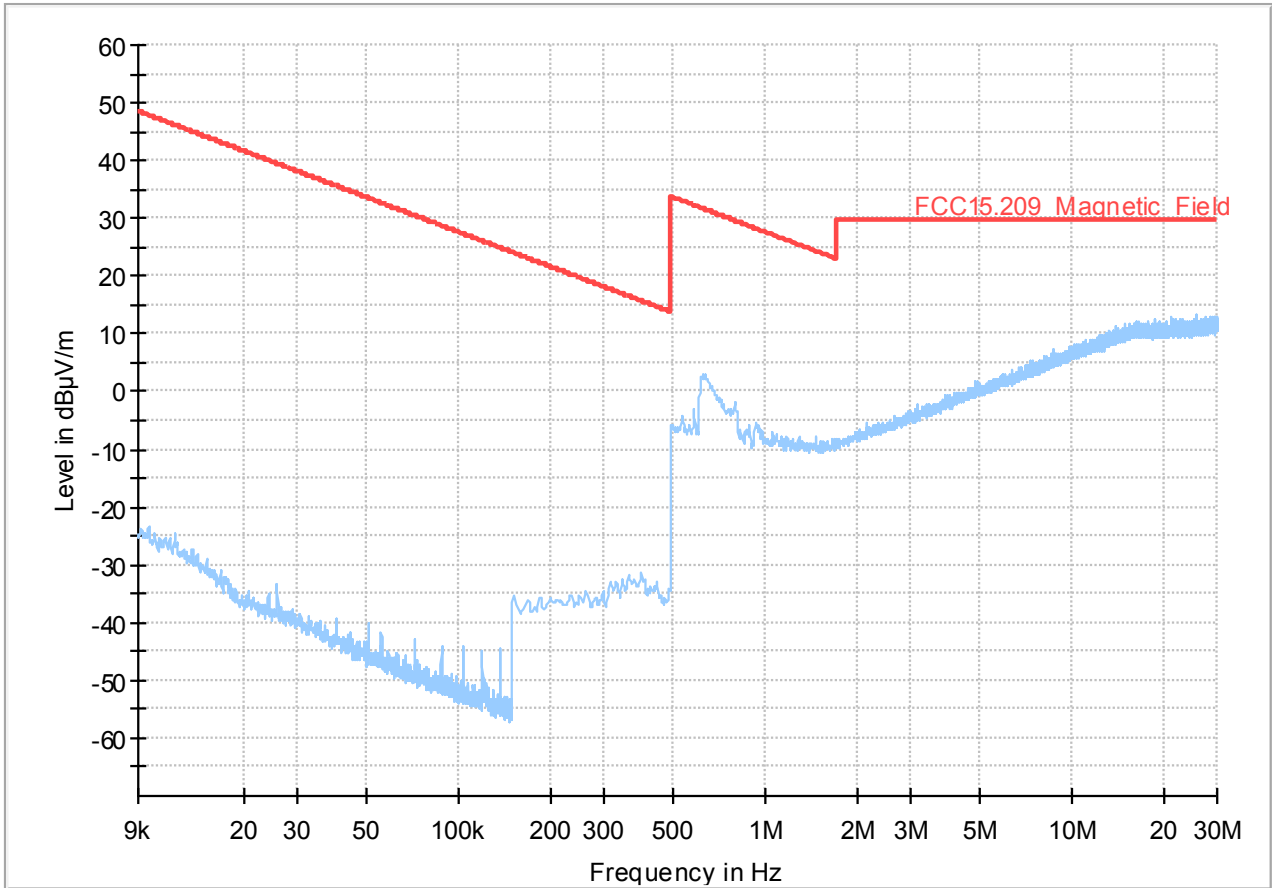

— Preview Result 1-PK+      \* Critical\_Freqs PK+  
— FCC15.209\_Magnetic\_Field      ◆ Final\_Result QPK

Annex A of TR no.: 23038521-32374-0

50. Test: RSE 30 MHz - 1 GHz, EUT No: 79, SN: R0091, Mode 1, a-mode, channel 64, 5320 MHz, 20 MHz channel bandwidth

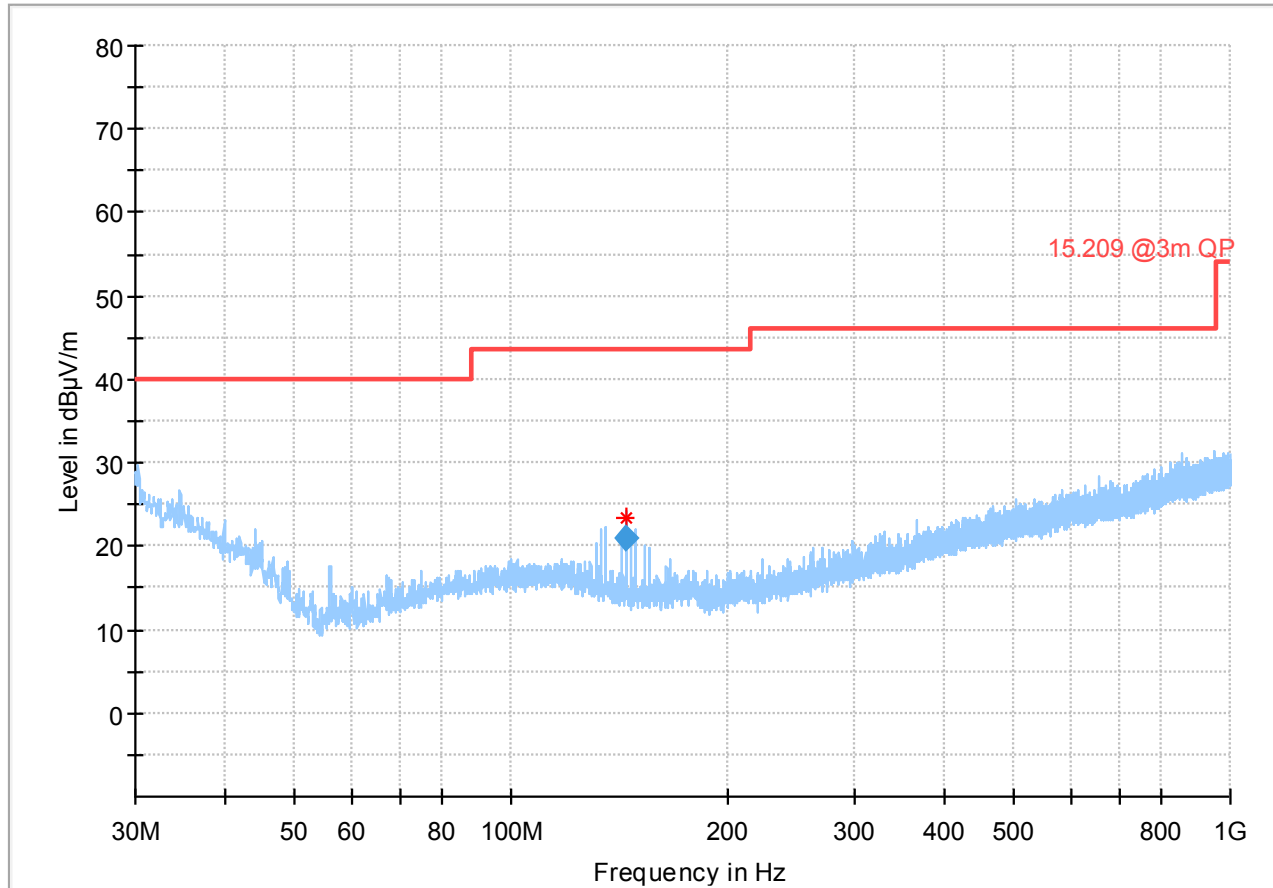

— Preview Result 1-PK+      \* Critical\_Freqs PK+  
— 15.209 @3m QP              ◆ Final\_Result QPK

Frequency (MHz)	QuasiPeak (dBµV/m)	Limit (dBµV/m)	Margin (dB)	Meas. Time (ms)	Bandwidth (kHz)	Height (cm)	Pol	Azimuth (deg)
144.436500	20.80	43.50	22.70	100.0	120.000	103.0	V	349.0