

Partial Test Report

Test report no.: 23038521-32373-2

Date of issue: 2023-07-28

Test result: The test item - **passed** - and complies with the listed standards.

Applicant

Mitsubishi Electric Corporation Sanda Works

Manufacturer

Mitsubishi Electric Corporation

Test Item

R1LOW-R

RF-Spectrum Testing

according to:

FCC 47 CFR Part 15

Radio Frequency Devices (Subpart C)

RSS-247 Issue 2

Digital Transmission Systems (DTSs), Frequency Hopping Systems (FHSs) and Licence-Exempt Local Area Network (LE-LAN) Devices

RSS-Gen Issue 5

General Requirements for Compliance of Radio Apparatus

Tested by
(name, function, signature)

Piotr Sardyko
Lab Manager

signature

Approved by
(name, function, signature)

Andreas Bender
Deputy Managing Director

signature

Applicant and Test item details	
Applicant	Mitsubishi Electric Corporation Sanda Works 2-3-33, Miwa, Sanda-City, Hyogo 669-1513 Japan DESIGN-A SECTION, MULTIMEDIA DESIGN DEPT. Fon: +81 79 559 3505 E-Mail: Kuriyama.Koichi@bc.MitsubishiElectric.co.jp
Manufacturer	Mitsubishi Electric Corporation 2-3-33, Miwa, Sanda-City, Hyogo 669-1513 Japan DESIGN-A SECTION, MULTIMEDIA DESIGN DEPT. Fon: +81 79 559 3505 E-Mail: Kuriyama.Koichi@bc.MitsubishiElectric.co.jp
Test item description	Automotive Display Audio
Model/Type reference	R1LOW-R
Standard specific information	
FCC ID	UJH-R1LOW-R
IC	662K-R1LOWR
PMN	R1LOW-R
HVIN variant ID#79	79
HVIN variant ID#80	80
FVIN	N/A
HMN	N/A
Frequency	2400 to 2483.5 MHz DTS band
Technology	Type of radio transmission: DSSS, OFDM Type of modulation: (D)BPSK, (D)QPSK, CCK, 16QAM, 64QAM
Number of channels	13 (20/22 MHz)
Antenna	Sheet metal antenna
Power supply	9 V – 16.5V, DC Battery
Temperature range	-40 °C to +75 °C

Disclaimer and Notes

The content of this report relates to the mentioned test sample(s) only.
Without a written permit of IBL-Lab GmbH, this test report shall not be reproduced, except in full.

The last valid version is available at TAMSys®.

Copyright ©: All rights reserved by IBL-Lab GmbH

Within this test report, a point / comma is used as a decimal separator.

If otherwise, a detailed note is added adjoined to its use.

IBL-Lab GmbH does not take test samples. The sample used for testing is provided by the applicant.

Decision rule:

Decision rule based on simple acceptance without guard bands, binary statement, based on mutually agreed uncertainty tolerances with expansion factor k=2 according to ILAC-G8:09/2019

1 TABLE OF CONTENTS

1	TABLE OF CONTENTS.....	3
2	GENERAL INFORMATION	4
2.1	Administrative details.....	4
2.2	Possible test case verdicts	4
2.3	Observations.....	5
2.4	Opinions and Interpretations	5
2.5	Revision History.....	5
2.6	Further documents.....	5
3	ENVIRONMENTAL & TEST CONDITIONS.....	6
3.1	Environmental conditions	6
3.2	Normal and extreme test conditions	6
4	TEST STANDARDS AND REFERENCES	6
5	EQUIPMENT UNDER TEST (EUT).....	7
5.1	Product Description	7
5.2	Test Item Description.....	7
5.3	Technical Data of Equipment	8
5.4	Additional Information.....	9
5.5	Test modes	10
6	SUMMARY OF TEST RESULTS.....	11
7	TEST RESULTS	12
7.1	Antenna Gain, radiated peak power	12
7.2	Band Edge Compliance (BEC), radiated	14
7.3	Radiated Spurious Emissions (RSE).....	16
8	TEST SETUP DESCRIPTION	18
8.1	Semi Anechoic Chamber with Ground Plane	18
8.2	Fully Anechoic Chamber	20
8.3	Radiated measurements > 18 GHz	22
8.4	Conducted measurements WLAN test system R&S TS 8997	23
9	MEASUREMENT UNCERTAINTIES.....	24

2 GENERAL INFORMATION

2.1 Administrative details

Testing laboratory	IBL-Lab GmbH Heinrich-Hertz-Allee 7 66386 Sankt Ingbert / Germany Fon: +49 6894 38938-0 Fax: +49 6894 38938-99 URL: www.ib-lenhardt.de E-Mail: info@ib-lenhardt.de
Accreditation	<p>The testing laboratory is accredited by Deutsche Akkreditierungsstelle GmbH (DAkKS) in compliance with DIN EN ISO/IEC 17025:2018.</p> <p>Scope of testing and registration number:</p> <ul style="list-style-type: none"> • Electronics, EMC, Radio D-PL-21375-01-01 • Electromagnetic Compatibility and Telecommunication (FCC requirements) Testing Laboratory Designation Number D-PL-21375-01-02 DE0024 • Telecommunication (TC) and Electromagnetic Compatibility (EMC) for Canadian Standards D-PL-21375-01-03 ISED Company Number 27156 Testing Laboratory CAB Identifier DE0020 <p>Website DAkKS: https://www.dakks.de/</p> <p>The Deutsche Akkreditierungsstelle GmbH (DAkKS) is also a signatory to the ILAC Mutual Recognition Arrangement</p>
Testing location	IBL-Lab GmbH Heinrich-Hertz-Allee 7 66386 St. Ingbert / Germany
Date of receipt of test samples	2023-06-28
Start – End of tests	2023-06-28 – 2023-07-10

2.2 Possible test case verdicts

Test sample meets the requirements	P (PASS) – the measured value is below the acceptance limit, AL = TL
Test sample does not meet the requirements	F (FAIL) – the measured value is above the acceptance limit, AL = TL
Test case does not apply to the test sample	N/A (Not applicable)
Test case not performed	N/P (Not performed)

2.3 Observations

No additional observations other than the reported observations within this test report have been made.

2.4 Opinions and Interpretations

No appropriate opinions or interpretations according ISO/IEC 17025:2017 clause 7.8.7 are within this test report.

2.5 Revision History

-0 Initial Version

-1:

- Test Report number was corrected on page 5 in Subchapter 2.6.

-2:

- Test Report number Version was corrected on page 5 in Subchapter 2.6.

This test report 23038521-32373-2 replaces the previous test report 23038521-32373-1.

2.6 Further documents

List of further applicable documents belonging to the present test report:

- TR-23038521-32373-2_AnnexA (test results EUT).pdf
- TR-23038521-32373-2_AnnexB (external photos EUT).pdf
- TR-23038521-32373-2_AnnexC (internal photos EUT).pdf
- TR-23038521-32373-2_AnnexD (test setup FCC - IC).pdf
- TR-21065798-20830-x.pdf (latest available version)
- TR-21065798-20830-x_AnnexA (test results EUT).pdf
- TR-21065798-20830-x_AnnexB (external photos EUT).pdf
- TR-21065798-20830-x_AnnexC (internal photos EUT).pdf
- TR-21065798-20830-x_AnnexD (test setup FCC - IC).pdf

3 ENVIRONMENTAL & TEST CONDITIONS

3.1 Environmental conditions

Temperature	20°C ± 5°C
Relative humidity	25-75 % r.H.
Barometric Pressure	860-1060 mbar
Power supply	230 V / 50 Hz

3.2 Normal and extreme test conditions

	minimum	nominal	maximum
Temperature	-/-	+25 °C	-/-
Relative humidity	-/-	50 % r.h.	-/-
Power supply	-/-	12.6 V DC	-/-

4 TEST STANDARDS AND REFERENCES

Test standard (accredited)	Description
FCC 47 CFR Part 15	Radio Frequency Devices (Subpart C)
RSS-247 Issue 2	Digital Transmission Systems (DTSs), Frequency Hopping Systems (FHSs) and Licence-Exempt Local Area Network (LE-LAN) Devices
RSS-Gen Issue 5	General Requirements for Compliance of Radio Apparatus

Test standard (not accredited)	Description
none	---

Reference	Description
ANSI C63.4-2014	American National Standard for Methods of Measurement of Radio-Noise Emissions from Low-Voltage Electrical and Electronic Equipment in the Range of 9 kHz to 40 GHz
ANSI C63.10-2013	American National Standard of Procedures for Compliance Testing of Unlicensed Wireless Devices
558074 D01 15.247 Meas Guide v05r02	Guidance for compliance measurements on digital transmission systems, frequency hopping spread spectrum systems and hybrid system devices operating under section 15.247 of the FCC rules

5 EQUIPMENT UNDER TEST (EUT)

5.1 Product Description

Automotive Display Audio

*: as declared by applicant

5.2 Test Item Description

Model name*	R1LOW-R
EUT status*	25MY PV
Model variants*	ID#79: mechanical variant 8F electrical variant 16 ID#80: mechanical variant 8F electrical variant 26
Serial number of EUT test samples*	ID#79: radiated EUT: R0091 conducted EUT: - ID#80: radiated EUT: R0047 conducted EUT: -
PCB identifier*	N211J71621
Hardware status*	NR-0C-R-25MY-PV
Software status*	Android 10

*: as declared by applicant; please see Annex B and Annex C to current Report for EUT photographs.

5.3 Technical Data of Equipment	
Operational frequency band*	2400 to 2483.5 MHz DTS band
Transmitter*	Chip QCA6574AU with 48 MHz TCXO (Module UGKZ5A3006A)
Technology*	802.11 b/g/n, DSSS, OFDM
Modulation type*	802.11 b: DBPSK, DQPSK, CCK 802.11 g: BPSK, QPSK, 16QAM, 64QAM 802.11 n: BPSK, QPSK, 16QAM, 64QAM
Data rate*	802.11 b: 1 Mbps – 11 Mbps 802.11 g: 6 Mbps – 54 Mbps 802.11 n: 6.5 Mbps – 144.4 Mbps
Number of channels*	13
Channel bandwidth*	22 MHz (b-mode) / 20 MHz (g-, n-mode)
Channel spacing*	5 MHz
Guard Interval*	802.11n: GI=800 ns, GI=400 ns
Antenna* Part name Antenna 0 Part name Antenna 1	Sheet metal antenna, 2342059-2 2342059-1
Antenna gain*	Antenna 0: -3.55 dBi, Antenna 1: -3.42 dBi
Number of Spatial Streams*	NSS=1, NSS=2
Rated RF Output Power*	Maximum rated RF output power is maximum measured RF output power value (see section 7.1) plus 2dB: 802.11 b: 13 dBm 802.11 g: 10 dBm 802.11 n: 10 dBm
Power supply, V_{nom}*	9 V – 16.5V, DC Battery, V _{nom} =12.6 V
Temperature range, T_{nom}*	-40 °C to +75 °C, T _{nom} =+25°C

*: as declared by applicant

Channels with **22 MHz (b-mode) / 20 MHz (g-, n-mode)** channel bandwidth:

2400 to 2483.5 DTS band channel number & center frequency													
channel	1	2	3	4	5	6	7	8	9	10	11	12	13
f_c / MHz	2412	2417	2422	2427	2432	2437	2442	2447	2452	2457	2462	2467	2472

5.4 Additional Information	
Model variant differences*	<ul style="list-style-type: none"> • R1LOW-R DV model with integrated sheet metal antenna and associated display, PCB ID NJ00193611 • R1LOW-R 25MY PV model with integrated sheet metal antenna and associated display, PCB ID N211J71621 <p>Applicant declares that transmitter modul with chip and sheet metal antenna are identical in R1LOW-R DV model (see IBL-Lab test report TR-21065798-20830) and R1LOW-R 25MY PV model.</p> <p>Mechanical variants of R1LOW-R 25MY PV model listed in section 5.2 refer to different dimensions of associated display.</p> <p>Electrical variants of R1LOW-R 25MY PV model listed in section 5.2 refer to different memory chipsets and multimedia chipsets and interfaces.</p> <p>Test results of R1LOW-R DV model are used for following test cases (see IBL-Lab test report TR-21065798-20830):</p> <ul style="list-style-type: none"> • DTS bandwidth (6 dB) • Occupied Channel Bandwidth (99%) • Peak power spectral density (PSD) • Band edge compliance (BEC), conducted • Conducted spurious emissions (CSE) • RF output power (conducted peak power) <p>Radiated R1LOW-R 25MY PV test samples of all mechanical model variants are used for following test cases:</p> <ul style="list-style-type: none"> • Antenna gain, radiated peak power <p>Radiated R1LOW-R 25MY PV test samples of all model variants are used for following test cases:</p> <ul style="list-style-type: none"> • Band edge compliance (BEC), radiated • Radiated spurious emissions (RSE) – worst case from R1LOW-R DV tests (see IBL-Lab test report TR-21065798-20830)
Ancillaries tested with	None
Additional equipment used for testing	Notebook with test tool

*: as declared by applicant

5.5 Test modes	
Mode 1, b-mode	22 MHz bandwidth, Modulation type: DBPSK 1 Mbps*
Mode 2, g-mode	20 MHz bandwidth, Modulation type: BPSK 6 Mbps*
Mode 3, n-HT20 mode	20 MHz bandwidth, Modulation type: BPSK 6.5 Mbps*
Channel	Channels used for testing are marked in bold in 20 MHz channel list (see section 5.3)
Antennas and transmit operating mode	Equipment with 2 antennas/transmit chains (antenna 0, antenna 1); apart from conducted output power all other test cases can be performed with one antenna only (antenna 0)
Worst case configuration with respect to RF output power	<p>Conducted RF output power of R1LOW-R DV model has been measured for following modulation types, antenna gains and data rates at low, mid, and high channel frequencies marked in bold in 20 MHz channel list (see section 5.3):</p> <ul style="list-style-type: none"> - 802.11b, DBPSK, 1 Mbps, antenna 0, antenna 1, antenna 0 + 1 - 802.11b, DQPSK, 2 Mbps, antenna 0 + 1 - 802.11b, CCK, 5.5 Mbps, antenna 0 + 1 - 802.11b, CCK, 11 Mbps, antenna 0 + 1 - 802.11g, BPSK, 6 Mbps, antenna 0, antenna 1, antenna 0 + 1 - 802.11g, QPSK, 12 Mbps, antenna 0 + 1 - 802.11g, 16 QAM, 24 Mbps, antenna 0 + 1 - 802.11g, 64 QAM, 24 Mbps, antenna 0 + 1 - 802.11n, BPSK, 6.5 Mbps, antenna 0, antenna 1 - 802.11n, QPSK, 13 Mbps, antenna 0, - 802.11n, 16 QAM, 26 Mbps, antenna 0 - 802.11n, 64 QAM, 52 Mbps, antenna 0 <p>* From conducted RF output measurements of R1LOW-R DV model test mode 1, 2, 3 have been selected based on measured maximum conducted output power</p>

**Worst case analysis according ANSI C63.10-2013 ch. 5.6.2.2 has been performed based on conducted RF output power measurements:

- for 802.11b, g WLAN technologies test tool provided by applicant allowed separate **and** simultaneous transmission using antenna port 0 and antenna port 1. For 802.11n WLAN technologies test tool provided by applicant allowed separate transmission using antenna port 0 and antenna port 1.

6 SUMMARY OF TEST RESULTS

Test specification
FCC 47 CFR Part 15 RSS-247 Issue 2 / RSS-Gen Issue 5

Clause	Requirement / Test Case	Result - Remark	Verdict
§15.247(a)(2) RSS-247, 5.2 (a)	DTS bandwidth (6 dB)	KDB 558074, clause: 8.2	- N/P - *
RSS Gen, 6.7	Occupied bandwidth (99%)	-/-	- N/P - *
§15.247(b)(3) RSS-247, 5.4 (d)	RF output power (conducted peak power)	KDB 558074, clause: 8.3.1	- N/P - *
§15.247(b)(4) RSS-247, 5.4 (d)	Antenna gain, Peak E.I.R.P.	-/-	- PASS -
§15.247(e) RSS-247, 5.2 (b)	Peak power spectral density (PSD)	KDB 558074, clause: 8.4	- N/P - *
§15.247(d) RSS-247, 5.5	Band edge compliance (BEC), conducted	KDB 558074, clause: 8.5	- N/P - *
§15.247(d) RSS-247, 5.5	Band edge compliance (BEC), radiated	KDB 558074, clause: 8.7	- PASS -
§15.247(d) RSS-247, 5.5	Conducted spurious emissions (CSE)	KDB 558074 DTS clause: 8.5	- N/P - *
§15.247(d) / §15.209 RSS-247, 5.5 / RSS-Gen, 8.9	Radiated spurious emissions (RSE)	-/-	- PASS -
§15.207 RSS-Gen, 8.8	AC conducted emissions	EUT is battery powered	- N/A -

*) see IBL-Lab test report TR-21065798-20830

Comments and observations

Following pages show requirements and references of FCC Part 15.247, ANSI C63.10 and KDB 558074 only. Same tests are also applicable and valid for RSS-247, with clauses given in table above.

7 TEST RESULTS

7.1 Antenna Gain, radiated peak power

Applicability

This requirement applies to all types of DTS equipment.

Description

The antenna gain is defined as the difference between radiated peak power (Peak EIRP) subtracted by the conducted peak power of the module, given in dBi.

Limit

§15.247

(b)(4) The conducted output power limit specified in paragraph (b) of this section is based on the use of antennas with directional gains that do not exceed 6 dBi.

Test setup: 8.2 with radiated test sample (see section 5.2), 8.4 with conducted test sample (see section 5.2); test setup photographs see Annex D to current Report

Test Results (antenna 0 + 1)

EUT ID #79, Mode 1	low channel	mid channel	high channel	Limit
Radiated peak power [dBm]	8.63	8.14	8.03	36
Antenna gain antenna 0 [dBi]*	-3.55	-3.55	-3.55	6
Antenna gain antenna 1 [dBi]*	-3.42	-3.42	-3.42	6

*) see section 5.3

EUT ID #80, Mode 1	low channel	mid channel	high channel	Limit
Radiated peak power [dBm]	6.95	8.34	8.23	36
Antenna gain antenna 0 [dBi]*	-3.55	-3.55	-3.55	6
Antenna gain antenna 1 [dBi]*	-3.42	-3.42	-3.42	6

*) see section 5.3

Comment:	---
-----------------	-----

Verdict	- PASS -	For plots please see Annex A to current Report
----------------	-----------------	------------------------------------------------

7.2 Band Edge Compliance (BEC), radiated
<p>Applicability This requirement applies to all types of DTS equipment.</p>
<p>Description Emissions within a restricted band and within 2 MHz of an authorized band edge may be measured using either the marker-delta method (ANSI C63.10, 6.10.6) or the integration method (ANSI C63.20, 11.13.3), provided that the DTS bandwidth (or EBW) edge falls within 2 MHz of the band edge. Otherwise, all unwanted emissions measurements shall be performed using the standard methods.</p>
<p>Limits §15.247 (d) In any 100 kHz bandwidth outside the frequency band in which the spread spectrum or digitally modulated intentional radiator is operating, the radio frequency power that is produced by the intentional radiator shall be at least 20 dB below that in the 100 kHz bandwidth within the band that contains the highest level of the desired power, based on either an RF conducted or a radiated measurement, provided the transmitter demonstrates compliance with the peak conducted power limits. If the transmitter complies with the conducted power limits based on the use of RMS averaging over a time interval, as permitted under paragraph (b)(3) of this section, the attenuation required under this paragraph shall be 30 dB instead of 20 dB. Attenuation below the general limits specified in §15.209(a) is not required. In addition, radiated emissions which fall in the restricted bands, as defined in §15.205(a), must also comply with the radiated emission limits specified in §15.209(a) (see §15.205(c)).</p> <p>RSS-247, 5.5 In any 100 kHz bandwidth outside the frequency band in which the spread spectrum or digitally modulated device is operating, the RF power that is produced shall be at least 20 dB below that in the 100 kHz bandwidth within the band that contains the highest level of the desired power, based on either an RF conducted or a radiated measurement, provided that the transmitter demonstrates compliance with the peak conducted power limits. If the transmitter complies with the conducted power limits based on the use of root-mean-square averaging over a time interval, as permitted under section 5.4(d), the attenuation required shall be 30 dB instead of 20 dB. Attenuation below the general field strength limits specified in RSS-Gen is not required.</p>
<p>Test procedure The marker-delta method as described in ANSI C63.10, 6.10.6 or the integration method as described in ANSI C63.10, 11.13.3 can be used to perform measurements of the unwanted emissions level at the band edges.</p>
<p>Test setup: 8.2 with radiated test sample (see 5.2)</p>

Test results (antenna 0 + 1)			
BEC	low channel AVG / Peak [dµV/m @3m]	high channel AVG / Peak [dµV/m @3m]	Limit AVG / Peak [dµV/m @3m]
EUT ID#79, Mode 1	≤ 45 AVG / ≤ 55 PK	≤ 52 AVG / ≤ 62 PK	≤ 54 AVG / ≤ 74 PK
EUT ID#80, Mode 1	≤ 45 AVG / ≤ 55 PK	≤ 52 AVG / ≤ 62 PK	≤ 54 AVG / ≤ 74 PK

Comment:	---
-----------------	-----

Verdict	- PASS -	For plots please see Annex A to current Report
----------------	-----------------	------------------------------------------------

7.3 Radiated Spurious Emissions (RSE)

Applicability

This requirement applies to all types of DTS equipment.

Description

Spurious emission / unwanted emissions are emission on a frequency or frequencies which are outside the authorized band and the level of which may be reduced without affecting the corresponding transmission of information. Spurious emissions include harmonic emissions, parasitic emissions, intermodulation products and frequency conversion products. Measurements shall be made to detect spurious emissions that may be radiated directly from the cabinet, control circuits, power leads, or intermediate circuit elements under normal conditions of installation and operation.

Limits

15.247(d) / §15.209

RSS-247, 5.5 / RSS-Gen, 8.9

In any 100 kHz bandwidth outside the frequency band in which the spread spectrum or digitally modulated intentional radiator is operating, the radio frequency power that is produced by the intentional radiator shall be at least 20 dB below that in the 100 kHz bandwidth within the band that contains the highest level of the desired power, based on either an RF conducted or a radiated measurement. Attenuation below the general limits specified in Section 15.209(a) is not required. In addition, radiated emissions which fall in the restricted bands, as defined in §15.205(a), must also comply with the radiated emission limits specified in §15.209(a) (see §15.205(c)).

Frequency [MHz]	Field Strength [$\mu\text{V}/\text{m}$] / [dB $\mu\text{V}/\text{m}$]	Measurement distance [m]
0.009 – 0.490	2400/F[kHz]	300
0.490 – 1.705	24000/F[kHz]	30
1.705 – 30.0	30.0 / 29.5	30
30 – 88	100 / 40.0	3
88 – 216	150 / 43.5	3
216 – 960	200 / 46.0	3
960 – 40 000	500 / 54.0	3

Note

Radiated Spurious Emissions (RSE) are performed for low / mid / high channel.



Test setup: 8.1, 8.2, 8.3 with radiated test sample (see section 5.2); for test setup photographs please see Annex D to current Report

Test results: Test Mode 1, b-mode, 22 MHz bandwidth, Modulation type: DBPSK 1 Mbps, antenna 0 + 1					
EUT ID / Channel	Frequency [MHz]	Peak/RMS Detector	Level* [dBm]	Limit [dBm]	Verdict
EUT ID#79, 1	see plots	MaxPeak	see plots	see plots	- PASS -
EUT ID#79, 13	see plots	MaxPeak	see plots	see plots	- PASS -
EUT ID#80, 1	see plots	MaxPeak	see plots	see plots	- PASS -
EUT ID#80, 13	see plots	MaxPeak	see plots	see plots	- PASS -

Comment:	---
-----------------	-----

Verdict	- PASS -	For plots please see Annex A to current Report *
----------------	-----------------	--------------------------------------------------

* description of line and marker for all radiated spurious emission (RSE) measurements:

-  positive Peak (Max Hold) trace during pre-scan
-  Max Peak value
-  final Quasi Peak value

8 TEST SETUP DESCRIPTION

8.1 Semi Anechoic Chamber with Ground Plane

Radiated measurements are performed in vertical and horizontal plane in the frequency range 30 MHz to 1 GHz in a Semi Anechoic Chamber with a metallic ground plane. The EUT is positioned on a non-conductive test table with a height of 0.80 m above the metallic ground plane that covers the whole chamber. The receiving antennas conform to specification ANSI C63.10-2013, American National Standard for Testing Unlicensed Wireless Devices. These antennas can be moved over the height range between 1.0 m and 4.5 m in order to search for maximum field strength emitted from the EUT. The measurement distances between EUT and receiving antennas are indicated in the test setups for the various frequency ranges. For each measurement, the EUT is rotated in all three axes until the maximum field strength is received. The wanted and unwanted emissions are received by a spectrum analyzer where the detector modes and resolution bandwidths over various frequency ranges are set according to requirement ANSI C63.

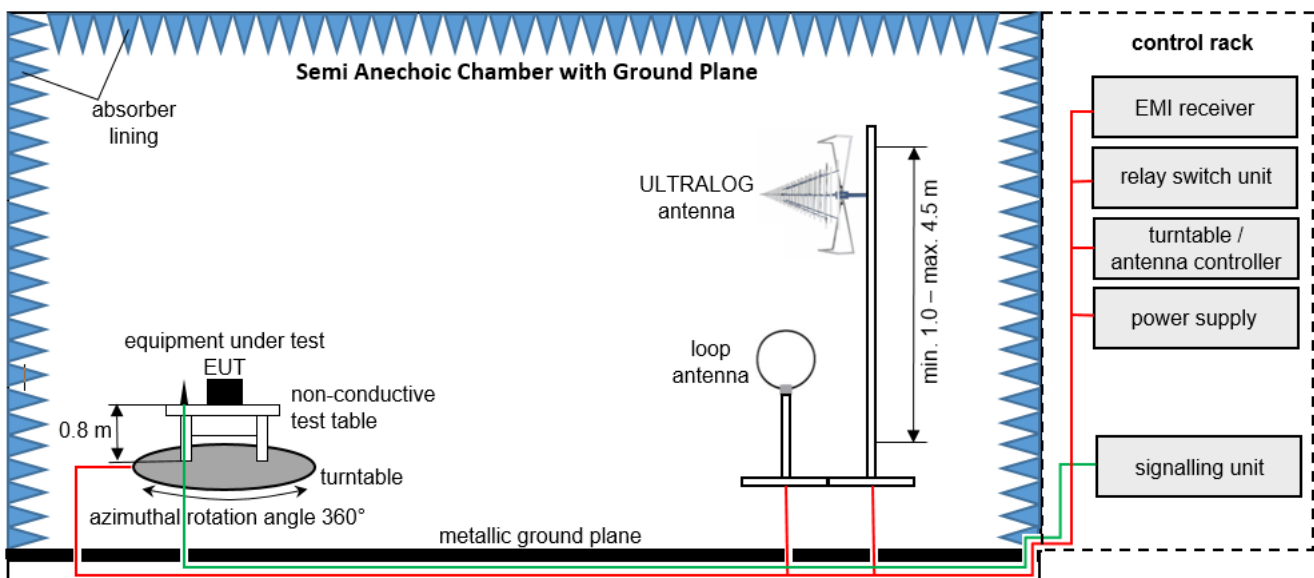

Measurement distance: loop antenna 3 m, ULTRALOG antenna 3 m
 EMC32 software version: 11.10.00

$$FS = UR + CL + AF$$

(FS-field strength; UR-voltage at the receiver; CL-loss of the cable; AF-antenna factor)

Example calculation:

$$FS [dB\mu V/m] = 12.35 [dB\mu V/m] + 1.90 [dB] + 16.80 [dB/m] = 31.05 [dB\mu V/m] (35.69 \mu V/m)$$

List of test equipment used:

No.	Equipment	Manufacturer	Type	Serial No.	INV. No.	Last / Next Calibration
1	Power Supply	Elektro-Automatik GmbH & Co. KG	EA-PSI 9080-40 T	2000230001	LAB000313	N/A
2	Test table	innco systems GmbH	PT1208-080-RH	-	LAB000306	N/A
3	Power Supply	Chroma	61604	616040005416	LAB000285	N/A
4	Positioner	matur GmbH	TD 1.5-10KG		LAB000258	N/A
5	Compressed Air	Implotex	1-850-30	-	LAB000256	N/A
6	EMI Test Receiver	Rohde & Schwarz	ESW26	101517	LAB000363	2023-02-16 → 2024-02-16
7	Semi-Anechoic Chamber (SAC)	Albatross Projects GmbH	SAC 5 (Babylon 5)	20168.PRB	LAB000235	2022-01-31 → 2025-01-31
8	Measurement Software	Rohde & Schwarz	EMC32 V11.00.10		LAB000226	N/A
9	Turntable	matur GmbH	TT2.0-2t	TT2.0-2t/921	LAB000225	N/A
10	Antenna Mast	matur GmbH	CAM4.0-P	CAM4.0-P/316	LAB000224	N/A
11	Antenna Mast	matur GmbH	BAM4.5-P	BAM4.5-P/272	LAB000223	N/A
12	Controller	matur GmbH	FCU 3.0	10082	LAB000222	N/A
13	Power Supply	Elektro-Automatik GmbH & Co. KG	PS 2042-10 B	2878350292	LAB000191	N/A
14	Pre-Amplifier	Schwarzbeck Mess-Elektronik OHG	BBV 9718 C	84	LAB000169	N/A
15	Open Switch and Control Platform	Rohde & Schwarz	OSP200 Base Unit 2HU	101748	LAB000149	N/A
16	Antenna	Rohde & Schwarz	HL562E	102001	LAB000123	2023-06-13 → 2026-06-13
17	Antenna	Rohde & Schwarz	HFH2-Z2E - Active Loop Antenna	100954	LAB000108	2023-04-05 → 2026-04-05

8.2 Fully Anechoic Chamber

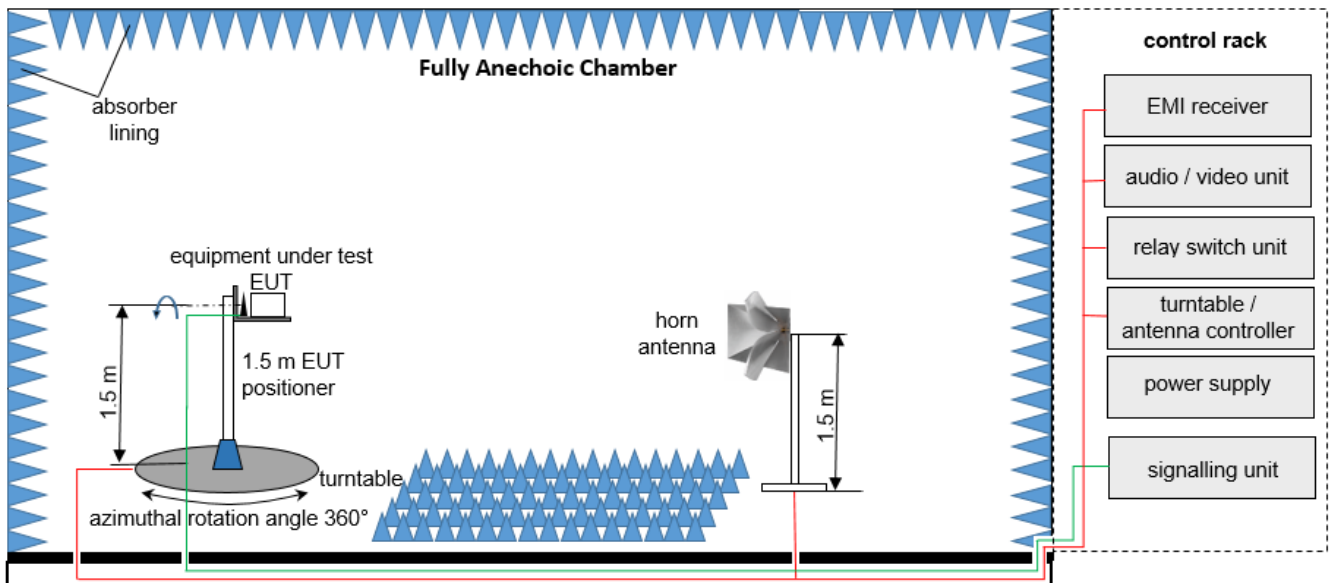

Measurement distance: horn antenna 3 meter
 EMC32 software version: 11.10.00

$FS = UR + CL + AF$
 (FS-field strength; UR-voltage at the receiver; CL-loss of the cable; AF-antenna factor)

Example calculation:
 $FS [dB\mu V/m] = 12.35 [dB\mu V/m] + 1.90 [dB] + 16.80 [dB/m] = 31.05 [dB\mu V/m] (35.69 \mu V/m)$

$OP = AV + D - G + CA$
 (OP-radiated output power; AV-analyzer value; D-free field attenuation of measurement distance;
 G-antenna gain+amplifier gain; CA-loss signal path)

Example calculation:
 $OP [dBm] = -65.0 [dBm] + 50 [dB] - 20 [dBi] + 5 [dB] = -30 [dBm] (1 \mu W)$

List of test equipment used:

No.	Equipment	Manufacturer	Type	Serial No.	INV. No.	Last / Next Calibration
1	Power Supply	Elektro-Automatik GmbH & Co. KG	EA-PSI 9080-40 T	2000230001	LAB000313	N/A
2	Test table	innco systems GmbH	PT1208-080-RH	-	LAB000306	N/A
3	Power Supply	Chroma	61604	616040005416	LAB000285	N/A
4	Positioner	matur GmbH	TD 1.5-10KG	-	LAB000258	N/A
5	Compressed Air	Implotex	1-850-30	-	LAB000256	N/A
6	EMI Test Receiver	Rohde & Schwarz	ESW26	101517	LAB000363	2023-02-16 → 2024-02-16
7	Semi-Anechoic Chamber (SAC)	Albatross Projects GmbH	SAC 5 (Babylon 5)	20168.PRB	LAB000235	2022-01-31 → 2025-01-31
8	Measurement Software	Rohde & Schwarz	EMC32 V11.00.10	-	LAB000226	N/A
9	Turntable	matur GmbH	TT2.0-2t	TT2.0-2t/921	LAB000225	N/A
10	Antenna Mast	matur GmbH	BAM4.5-P	BAM4.5-P/272	LAB000223	N/A
11	Controller	matur GmbH	FCU 3.0	10082	LAB000222	N/A
12	Power Supply	Elektro-Automatik GmbH & Co. KG	PS 2042-10 B	2878350292	LAB000191	N/A
13	Pre-Amplifier	Schwarzbeck Mess-Elektronik OHG	BBV 9718 C	84	LAB000169	N/A
14	Open Switch and Control Platform	Rohde & Schwarz	OSP200 Base Unit 2HU	101748	LAB000149	N/A
15	Antenna	Rohde & Schwarz	HF907	102898	LAB000124	2023-06-13 → 2026-06-13
16	HP-filter	AtlantRF	-	-	LAB000382	N/A

8.3 Radiated measurements > 18 GHz

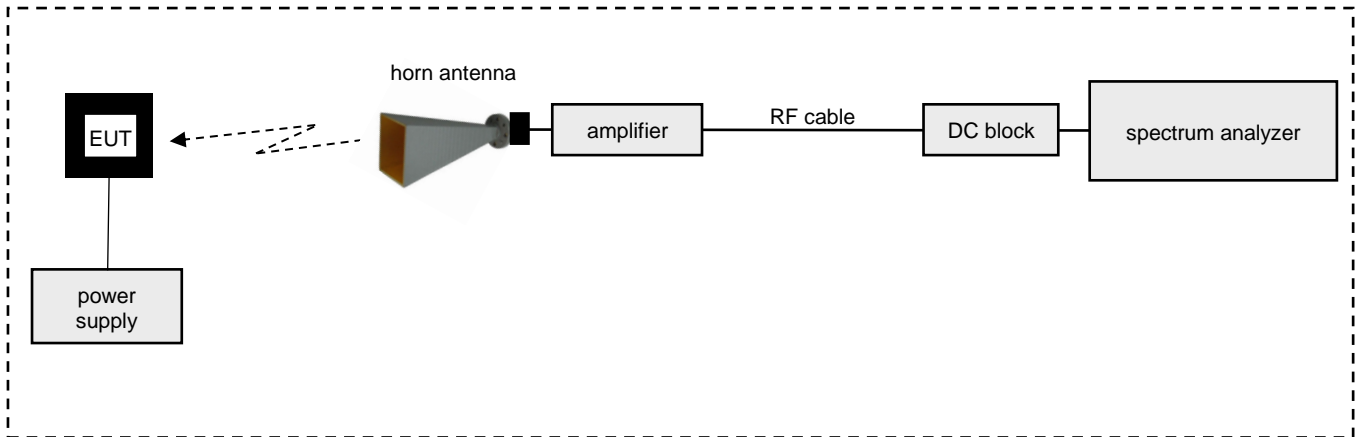

List of test equipment used:

No.	Equipment	Manufacturer	Type	Serial No.	INV. No.	Last / Next Calibration
1	Test table	innco systems GmbH	PT0707-RH light	-	LAB000303	N/A
2	WG-Coax-Adapter	Flann Microwave Ltd	20093-TF30 UBR220	273374	LAB000181	N/A
3	Coaxial Cable	Huber & Suhner	SF101/1.5m	503987/1	LAB000165	N/A
4	Antenna	Flann Microwave Ltd	20240-20	266403	LAB000128	2023-06-29 → 2026-06-29
4	Antenna	Flann Microwave Ltd	20240-20	270447	LAB000129	2023-07-01 → 2026-07-01
6	Spectrum Analyser	Rohde & Schwarz	FSW43	101391	LAB000289	2022-09-23 → 2023-09-23

8.4 Conducted measurements WLAN test system R&S TS 8997

The EUT's RF signal is coupled out by the antenna connector which is supplied by the manufacturer. The losses for all signal paths are first checked within a calibration. The measurement readings on the signalling unit/spectrum analyzer are corrected by the specific test set-up loss. The attenuator, power divider, signalling unit and the spectrum analyzer are impedance matched on 50 Ohm.

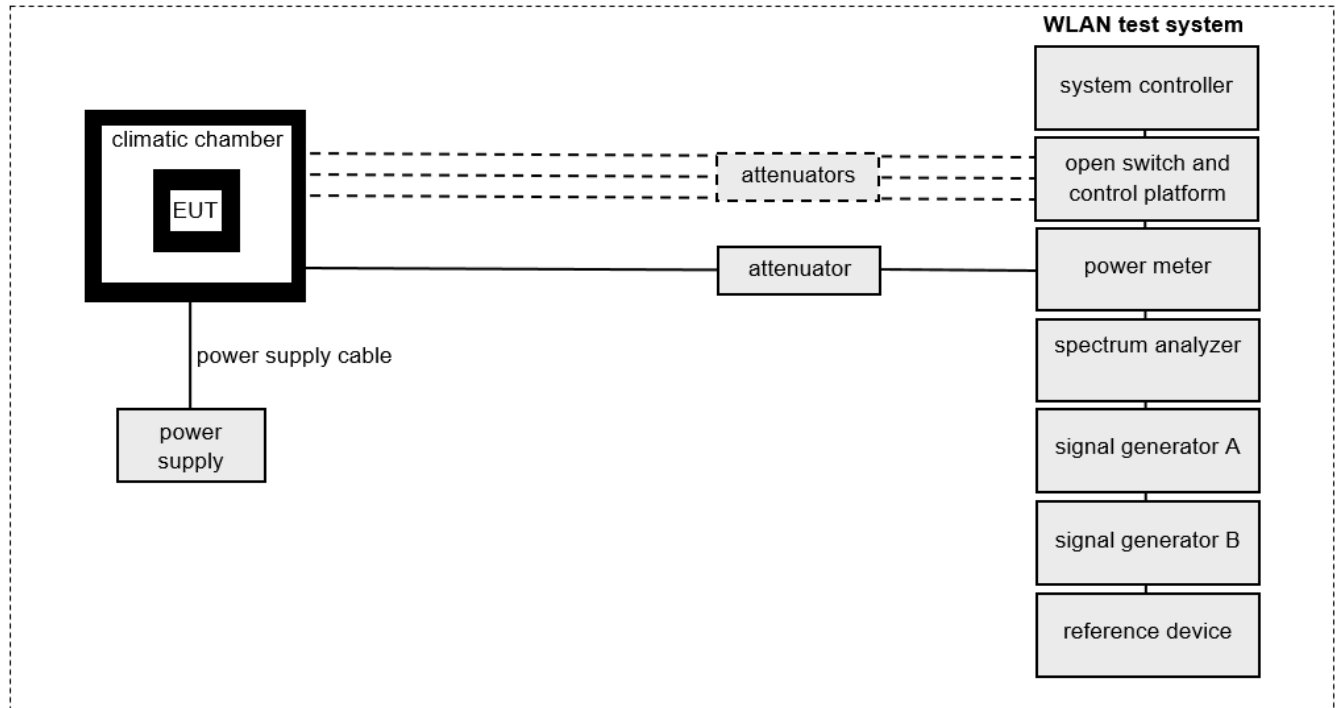

EMC32/WMS32 software version: 11.00.00

List of test equipment used:

No.	Equipment	Manufacturer	Type	Serial No.	INV. No.	Last / Next Calibration
1	TS8997-Rack	Rohde & Schwarz	TS8997-Rack	100829	LAB000322	N/A
2	Open Switch and Control Platform	Rohde & Schwarz	OSP-B157WX	101247	LAB000280	N/A
3	Open Switch and Control Platform	Rohde & Schwarz	OSP-B157W8	100982	LAB000279	N/A
4	Spectrum Analyser	Rohde & Schwarz	FSV40	101403	LAB000278	2021-06-15 → 2024-06-15
5	Signal Generator	Rohde & Schwarz	SMBV100A	258240	LAB000277	2021-08-31 → 2024-08-31
6	Signal Generator	Rohde & Schwarz	SMB100A-20	178175	LAB000276	2021-05-27 → 2024-05-31
7	Radio Communication Tester	Rohde & Schwarz	CMW270	101479	LAB000275	N/A
8	Controller	Hewlett Packard	ATS-Z230	101379	LAB000274	N/A
9	Power Supply	EA	PS 2042-10 B	2878350263	LAB000190	N/A

9 MEASUREMENT UNCERTAINTIES

Radio frequency	$\leq \pm 1 \times 10^{-7}$
RF power, conducted	$\leq \pm 0.75$ dB
Power spectral density	$\leq \pm 3$ dB
Maximum frequency deviation	$\leq \pm 5$ %
Deviation limitation Duty Cycle, Tx-sequence, Tx-gap	$\leq \pm 5$ %
Occupied channel bandwidth	$\leq \pm 5$ %
Conducted spurious emission of transmitter	$\leq \pm 4$ dB
Conducted emission of receivers	$\leq \pm 4$ dB
Radiated emission of transmitter	$\leq \pm 6$ dB
Radiated emission of receiver	$\leq \pm 6$ dB
Temperature	$\leq \pm 2.5$ °C
Humidity	$\leq \pm 10$ %

The indicated expanded measurement uncertainty corresponds to the standard measurement uncertainty for the measurement results multiplied by the coverage factor $k = 2$. It was determined in accordance with EA-4/02 M:2013. The true value is located in the corresponding interval with a probability of 95 %.

End of Test Report

Annex A

Test results of EUT

part of / in addition to

Test report no.: 23038521-32373-2

Tested by
(name, function, signature)

Piotr Sardyko
Lab Manager

A handwritten signature in black ink, appearing to be "Piotr Sardyko", written over a horizontal line.

signature

Approved by
(name, function, signature)

Andreas Bender
Deputy Managing Director

signature

TABLE OF CONTENTS

TABLE OF CONTENTS.....	2
TEST RESULTS	3
Peak EIRP	3
EUT No 79.....	3
EUT No 80.....	6
Band Edge Compliance (BEC)	9
EUT No 79.....	9
EUT No 80.....	15
Radiated Spurious Emissions (RSE)	21
EUT No 79.....	21
EUT No 80.....	33
Revision History	45

TEST RESULTS

Peak EIRP

EUT No 79

1. Test: Peak EIRP, EUT No: 79, SN: R0091, Mode 1, b-mode, channel 1, 2412 MHz

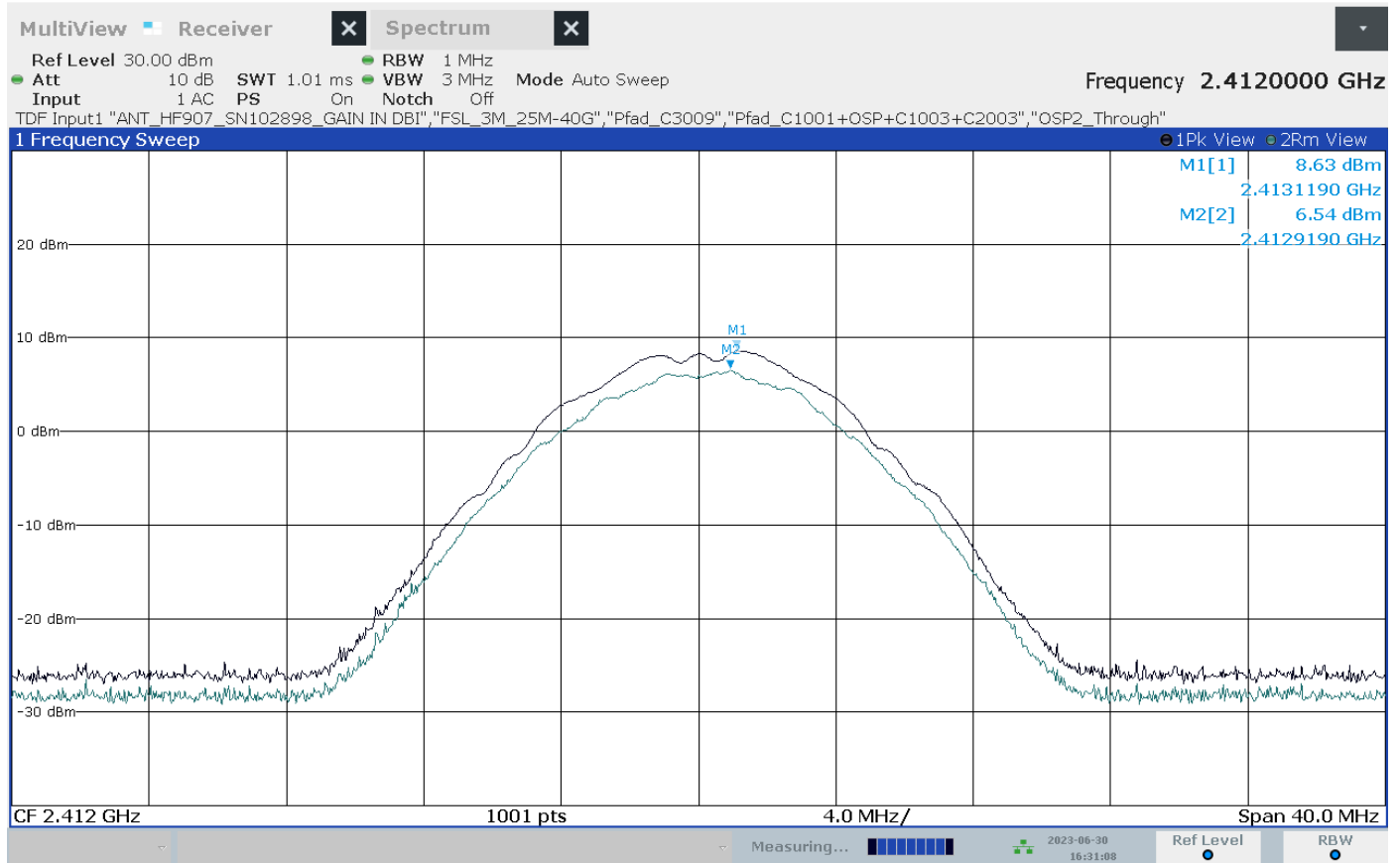

04:31:09 06/30/2023

Annex A of TR no.: 23038521-32373-2

2. Test: Peak EIRP, EUT No: 79, SN: R0091, Mode 1, b-mode, channel 8, 2447 MHz

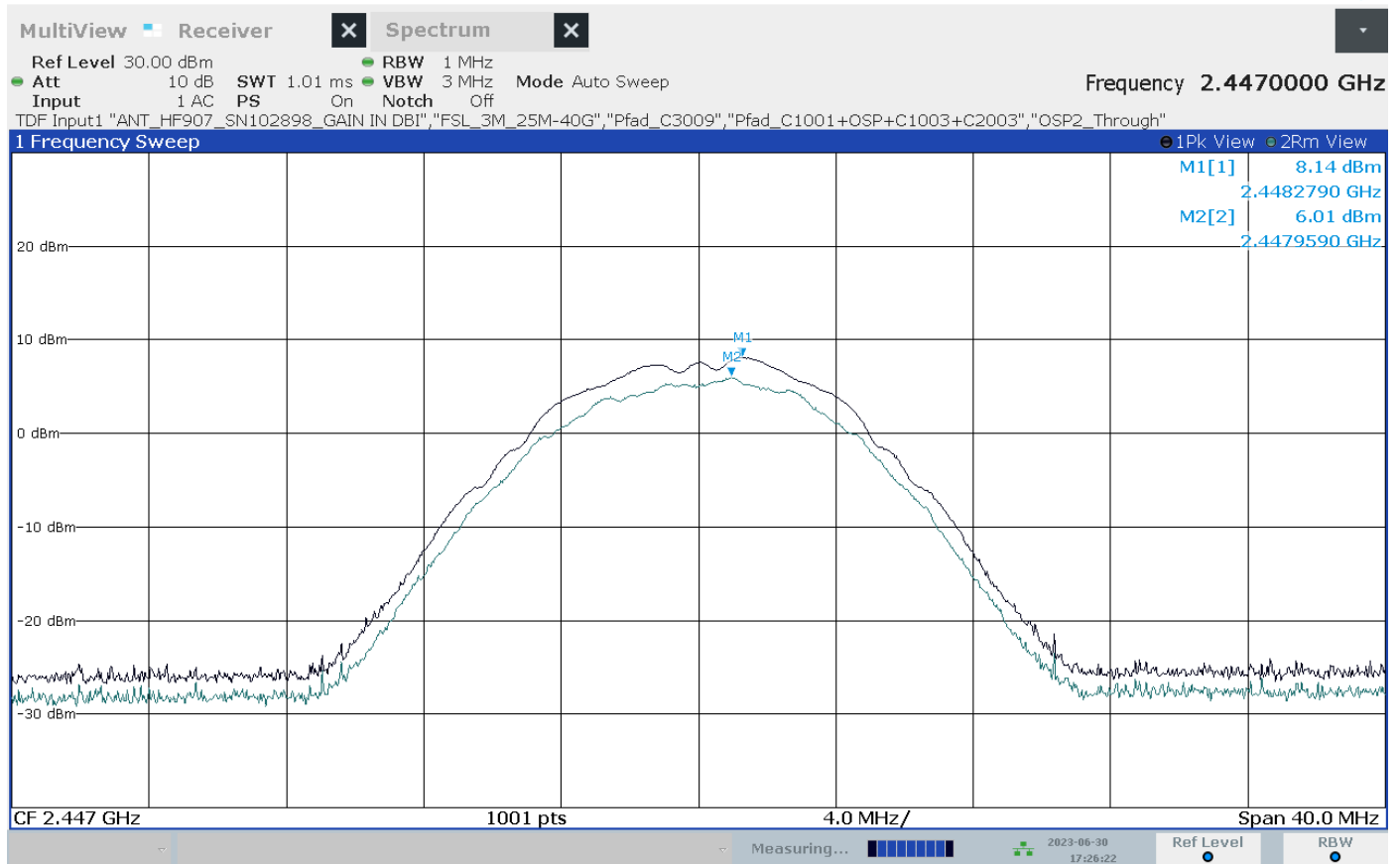

05:26:22 06/30/2023

Annex A of TR no.: 23038521-32373-2

3. Test: Peak EIRP, EUT No: 79, SN: R0091, Mode 1, b-mode, channel 13, 2472 MHz

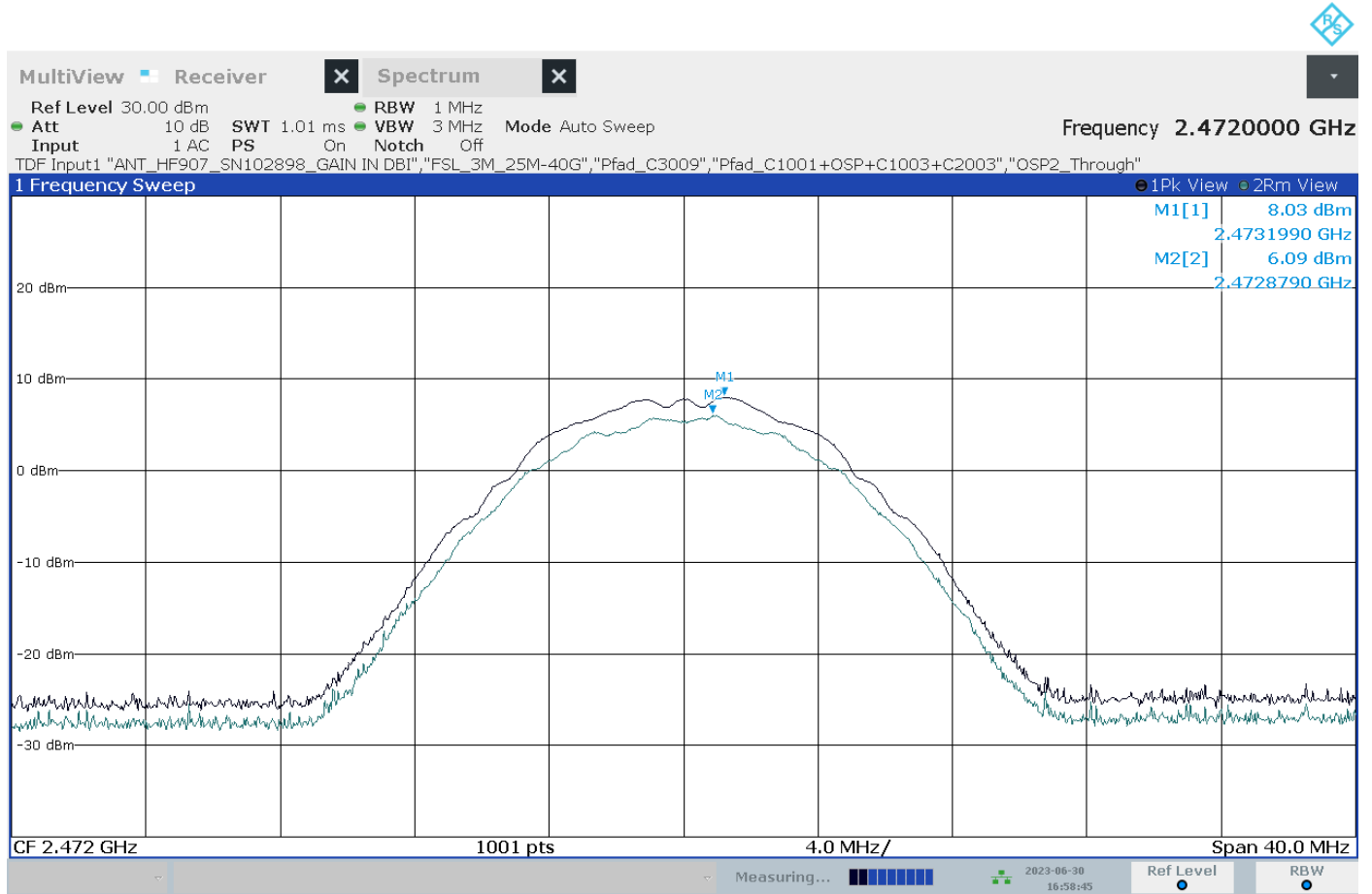

04:58:45 06/30/2023

EUT No 80

4. Test: Peak EIRP, EUT No: 80, SN: R0047, Mode 1, b-mode, channel 1, 2412 MHz

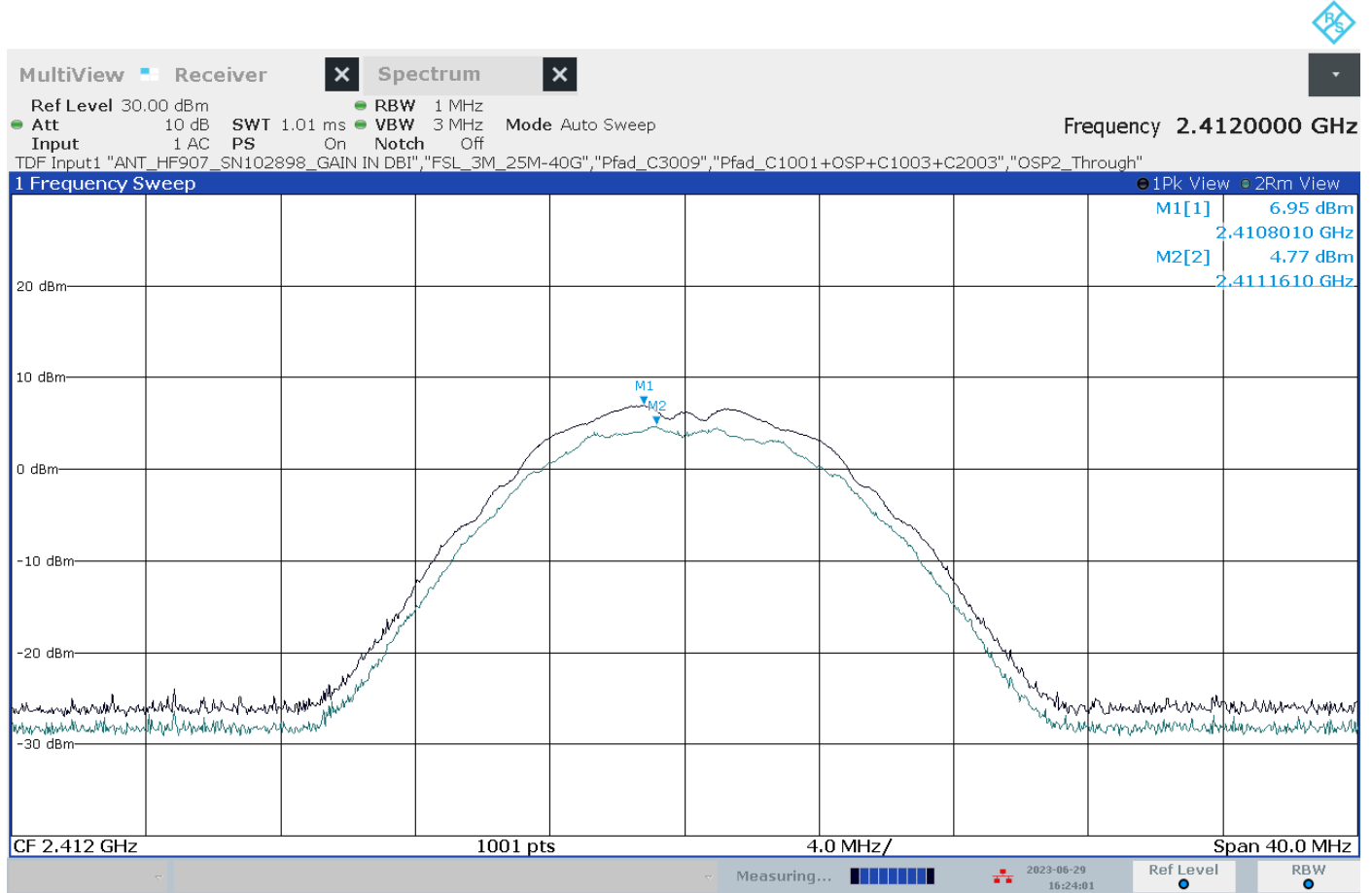

04:24:01 06/29/2023

Annex A of TR no.: 23038521-32373-2

5. Test: Peak EIRP, EUT No: 80, SN: R0047, Mode 1, b-mode, channel 8, 2447 MHz

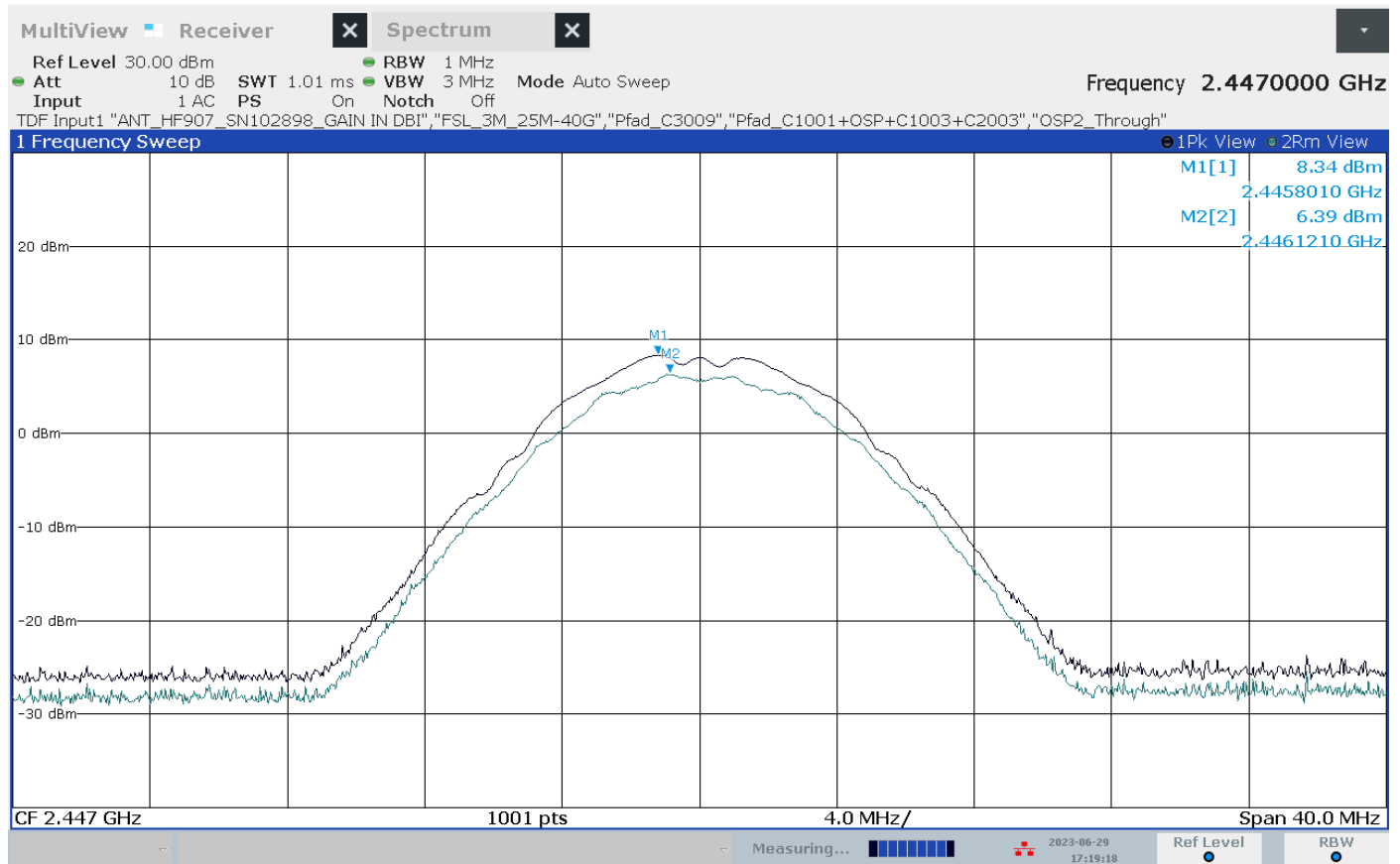

05:19:18 06/29/2023

6. Test: Peak EIRP, EUT No: 80, SN: R0047, Mode 1, b-mode, channel 13, 2472 MHz

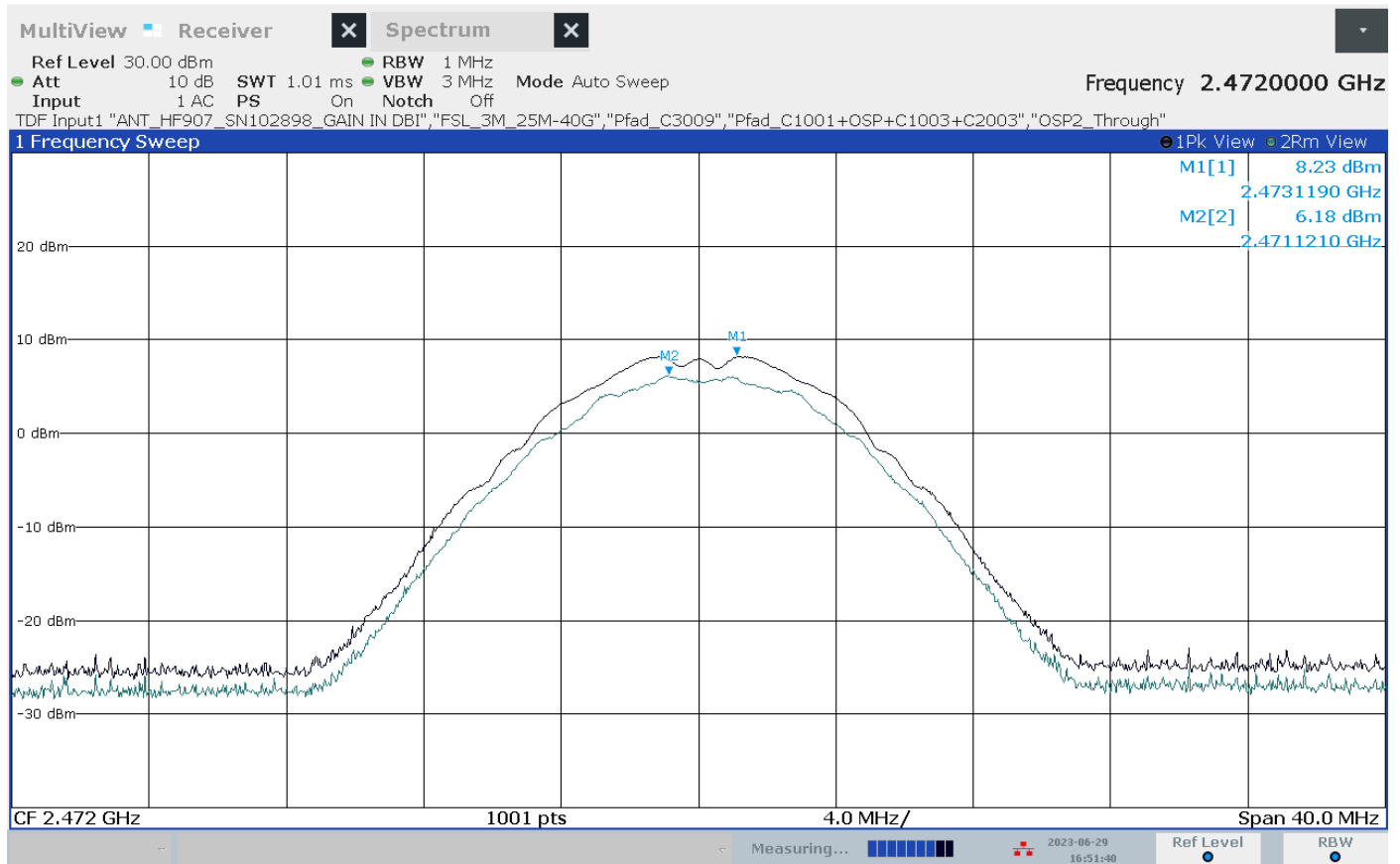

04:51:40 06/29/2023

Annex A of TR no.: 23038521-32373-2

Band Edge Compliance (BEC)

EUT No 79

7. Test: Band Edge Compliance (BEC), EUT No: 79, SN: R0091, Mode 1, b-mode, channel 1, 2412 MHz

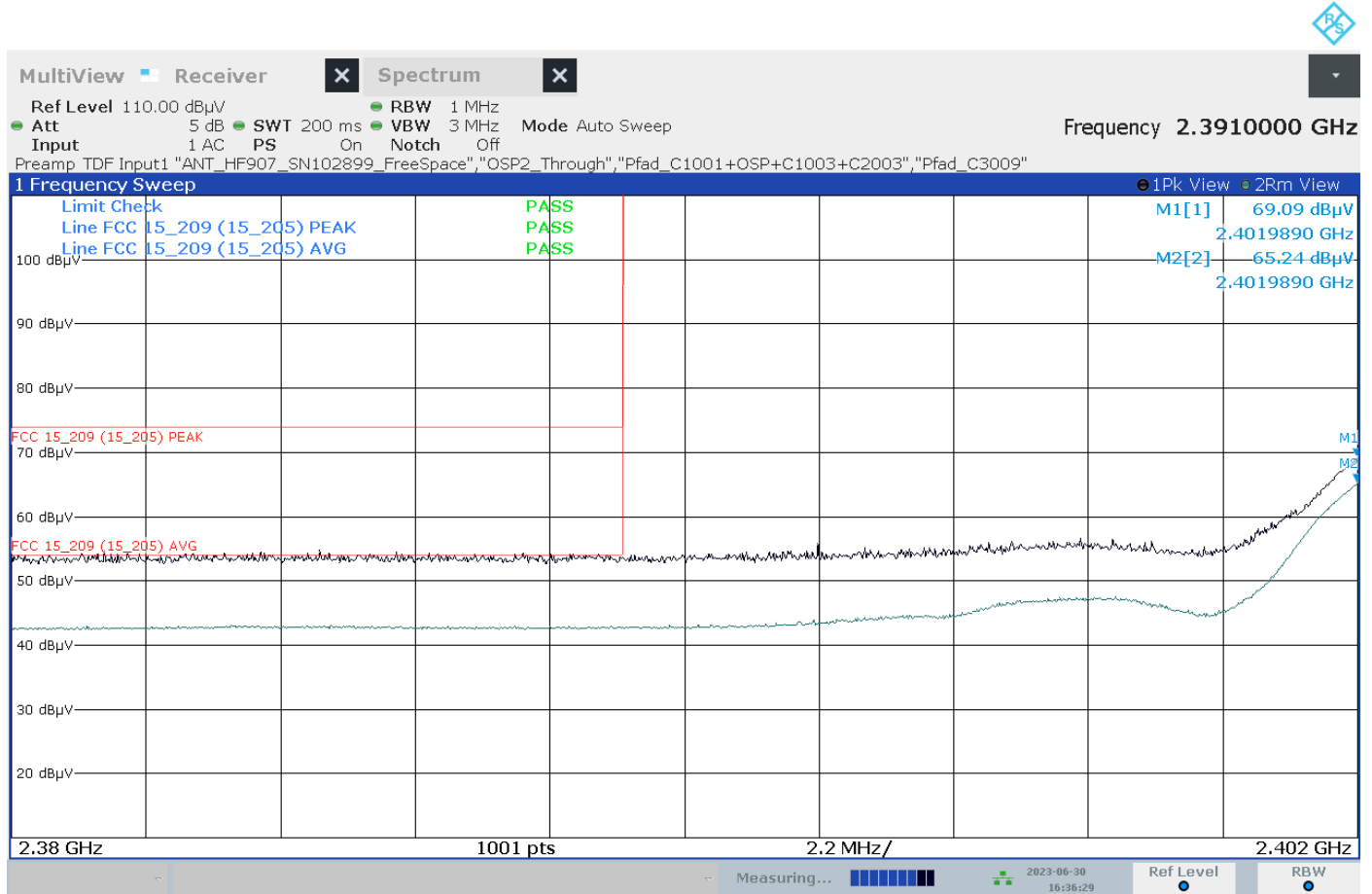

04:36:30 06/30/2023

Annex A of TR no.: 23038521-32373-2

8. Test: Band Edge Compliance (BEC), EUT No: 79, SN: R0091, Mode 2, g-mode, channel 1, 2412 MHz

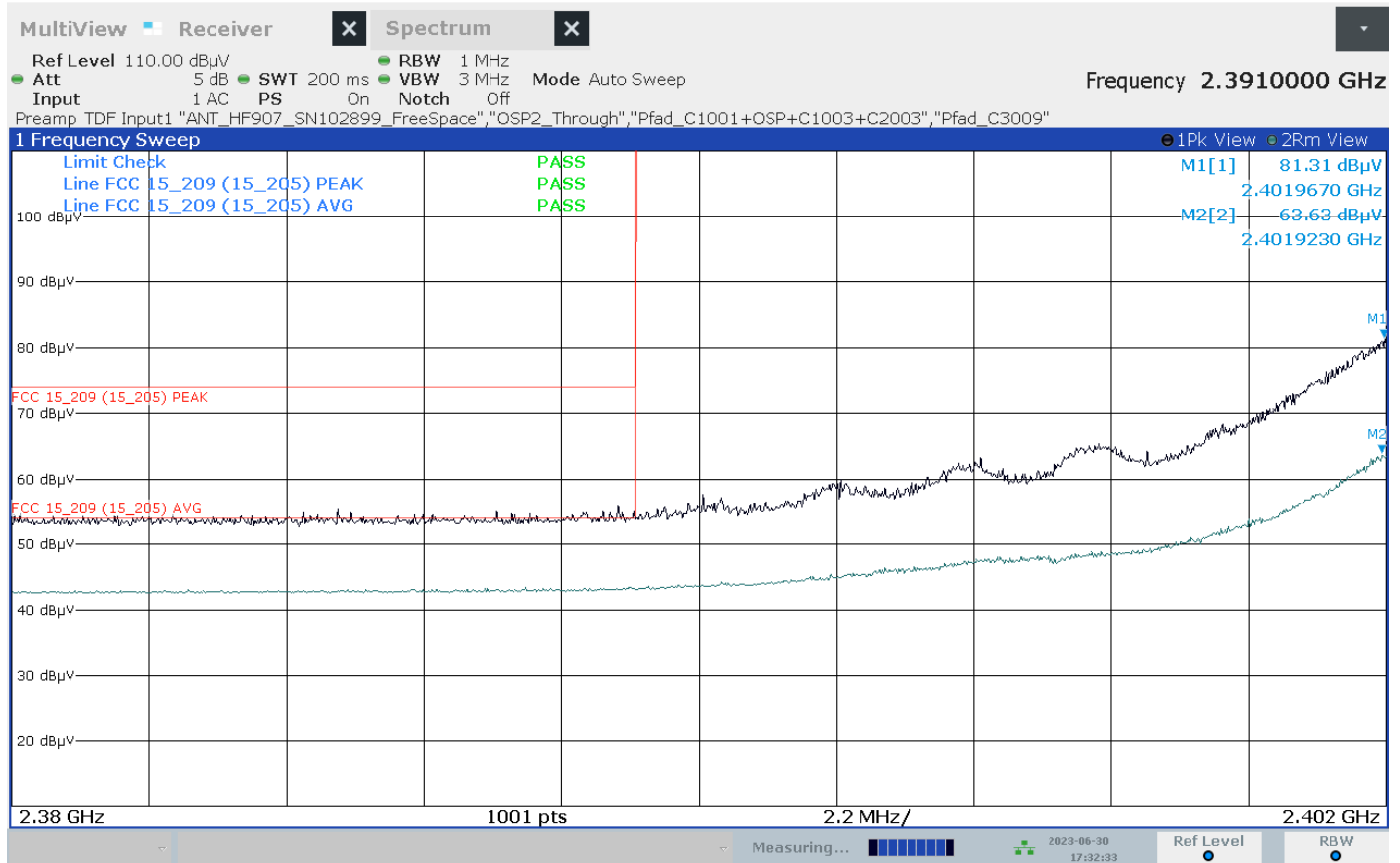

05:32:33 06/30/2023

Annex A of TR no.: 23038521-32373-2

9. Test: Band Edge Compliance (BEC), EUT No: 79, SN: R0091, Mode 3, n-HT20 mode, channel 1, 2412 MHz

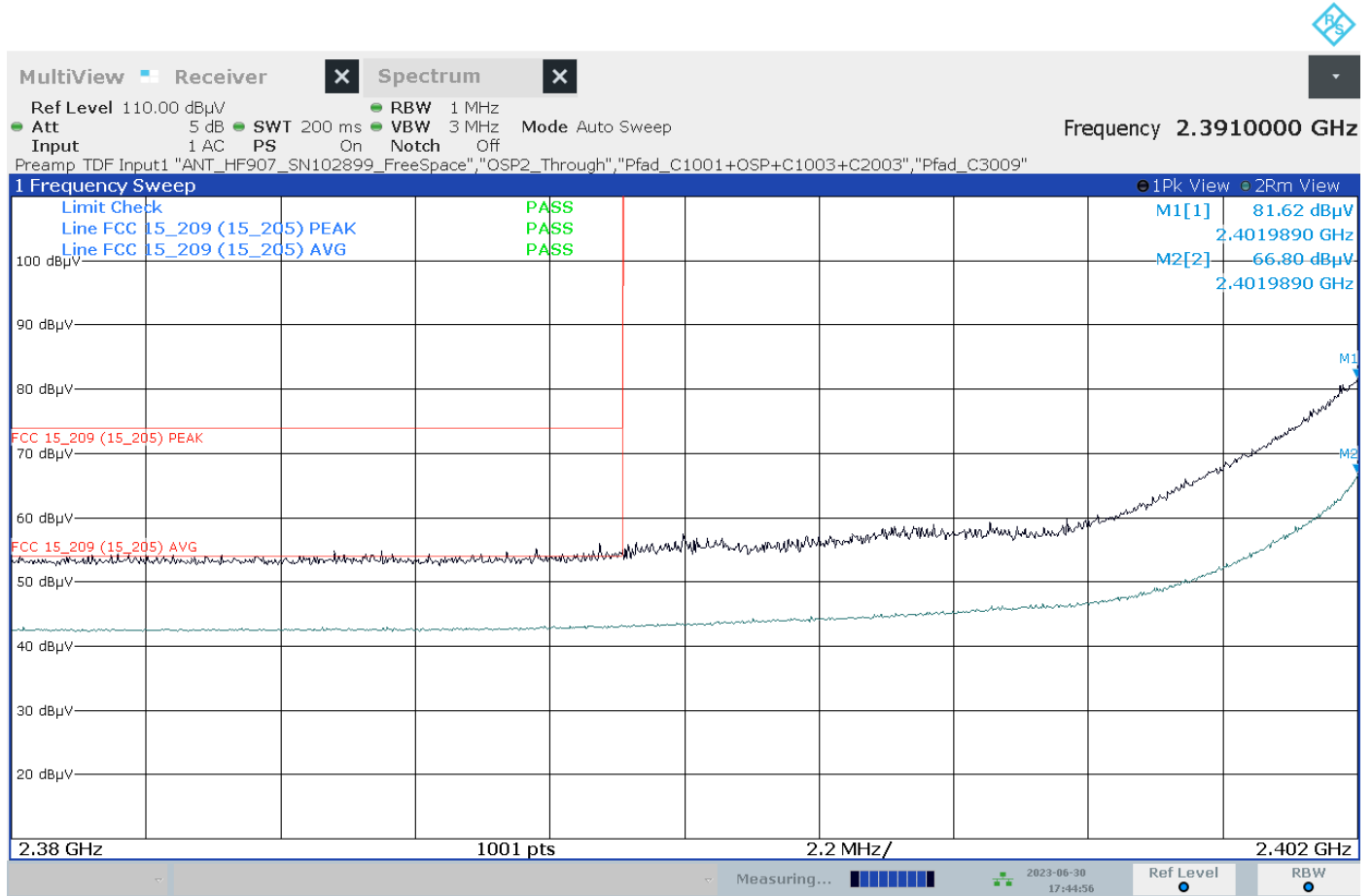

05:44:57 06/30/2023

Annex A of TR no.: 23038521-32373-2

10. Test: Band Edge Compliance (BEC), EUT No: 79, SN: R0091, Mode 1, b-mode, channel 13, 2472 MHz

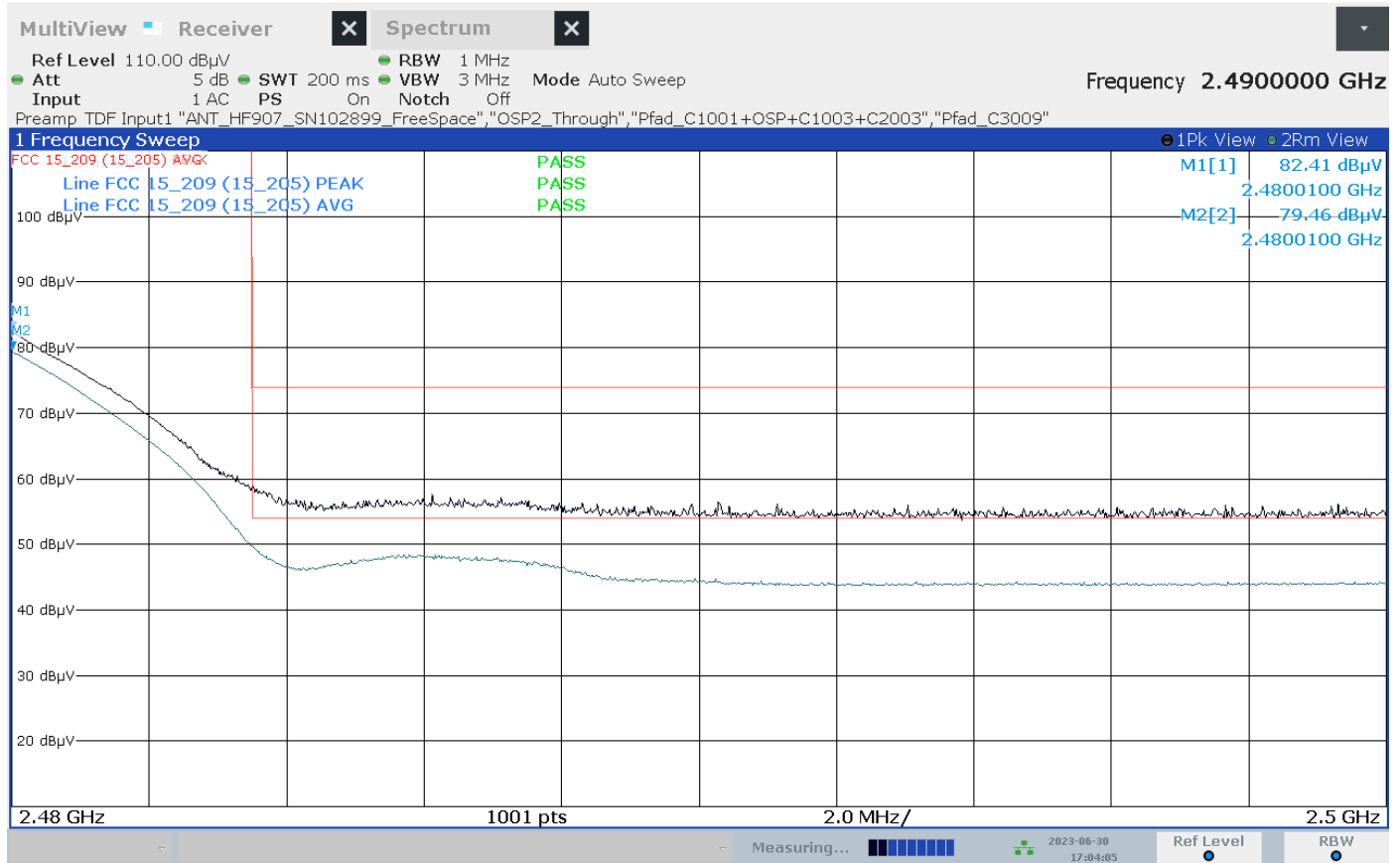

05:04:06 06/30/2023

11. Test: Band Edge Compliance (BEC), EUT No: 79, SN: R0091, Mode 2, g-mode, channel 13, 2472 MHz

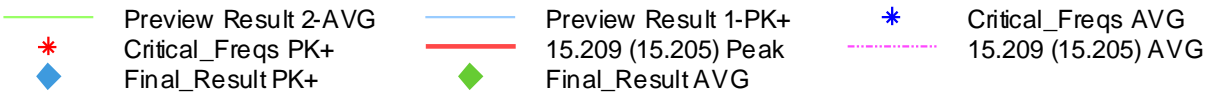
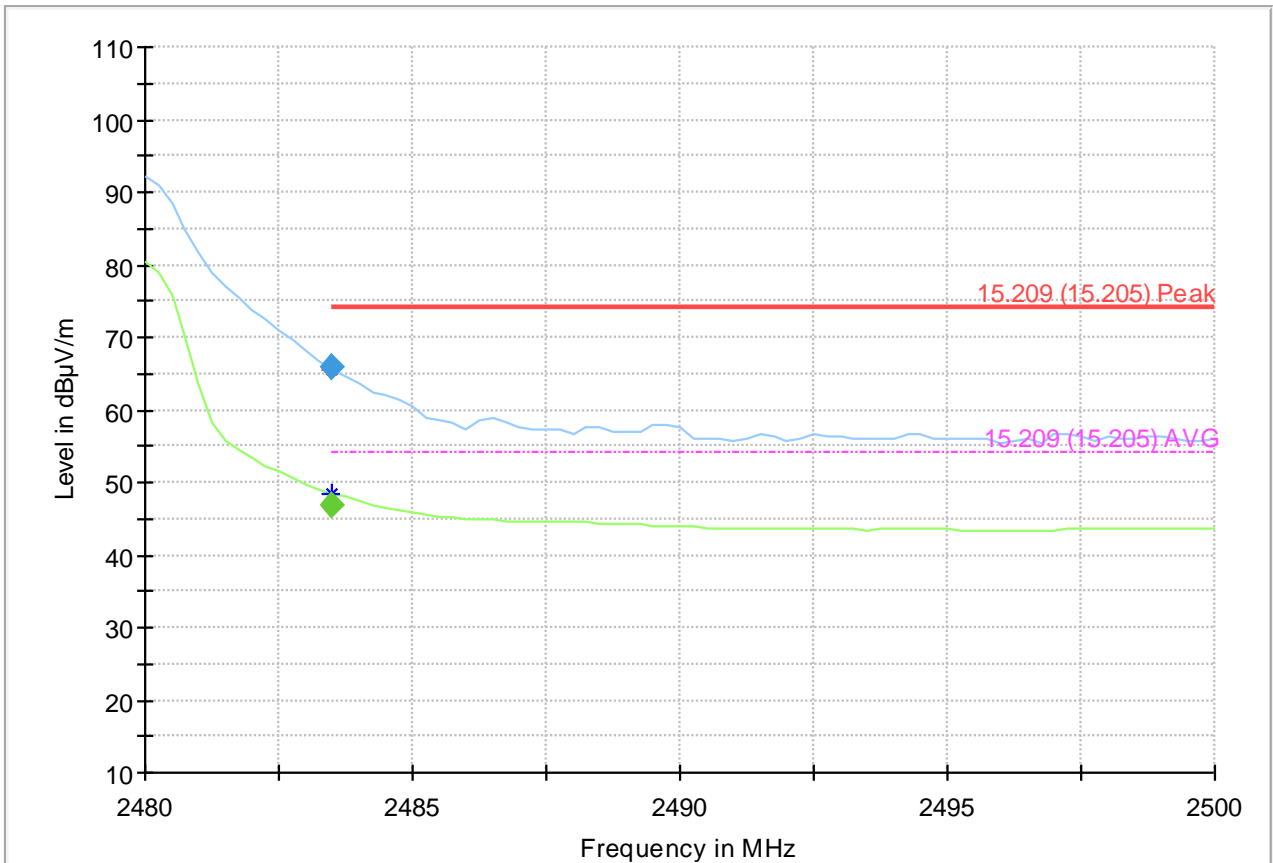

Final_Result

Frequency (MHz)	MaxPeak (dBµV/m)	Average (dBµV/m)	Limit (dBµV/m)	Margin (dB)	Meas. Time (ms)	Bandwidth (kHz)	Height (cm)	Pol
2483.500000	---	46.96	54.00	7.04	100.0	1000.000	150.0	H
2483.500000	65.86	---	74.00	8.14	100.0	1000.000	150.0	V

12. Test: Band Edge Compliance (BEC), EUT No: 79, SN: R0091, Mode 3, n-HT20 mode, channel 13, 2472 MHz

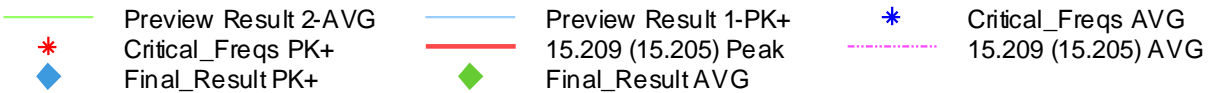
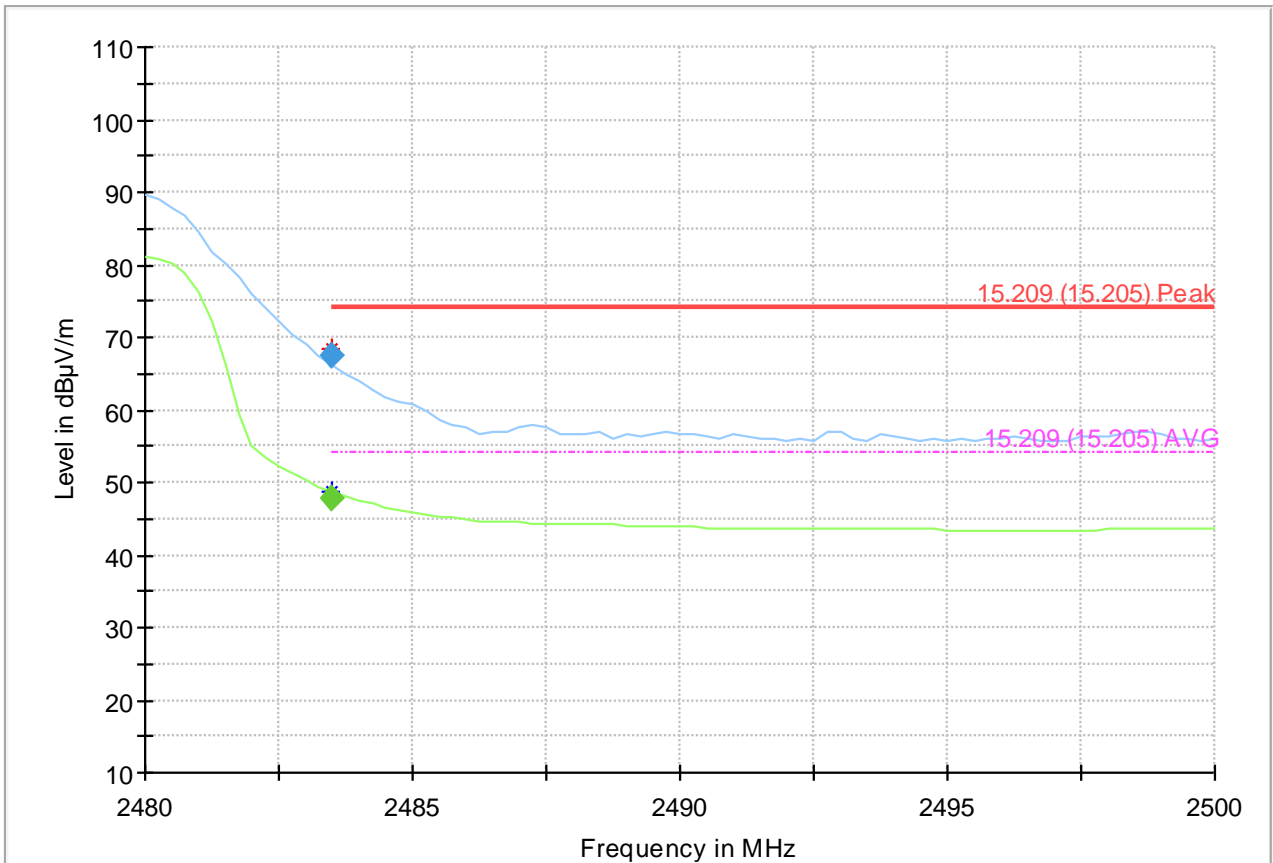

Final_Result

Frequency (MHz)	MaxPeak (dBµV/m)	Average (dBµV/m)	Limit (dBµV/m)	Margin (dB)	Meas. Time (ms)	Bandwidth (kHz)	Height (cm)	Pol
2483.500000	---	47.77	54.00	6.23	100.0	1000.000	150.0	V
2483.500000	67.35	---	74.00	6.65	100.0	1000.000	150.0	V

Annex A of TR no.: 23038521-32373-2

EUT No 80

13. Test: Band Edge Compliance (BEC), EUT No: 80, SN: R0047, Mode 1, b-mode, channel 1, 2412 MHz

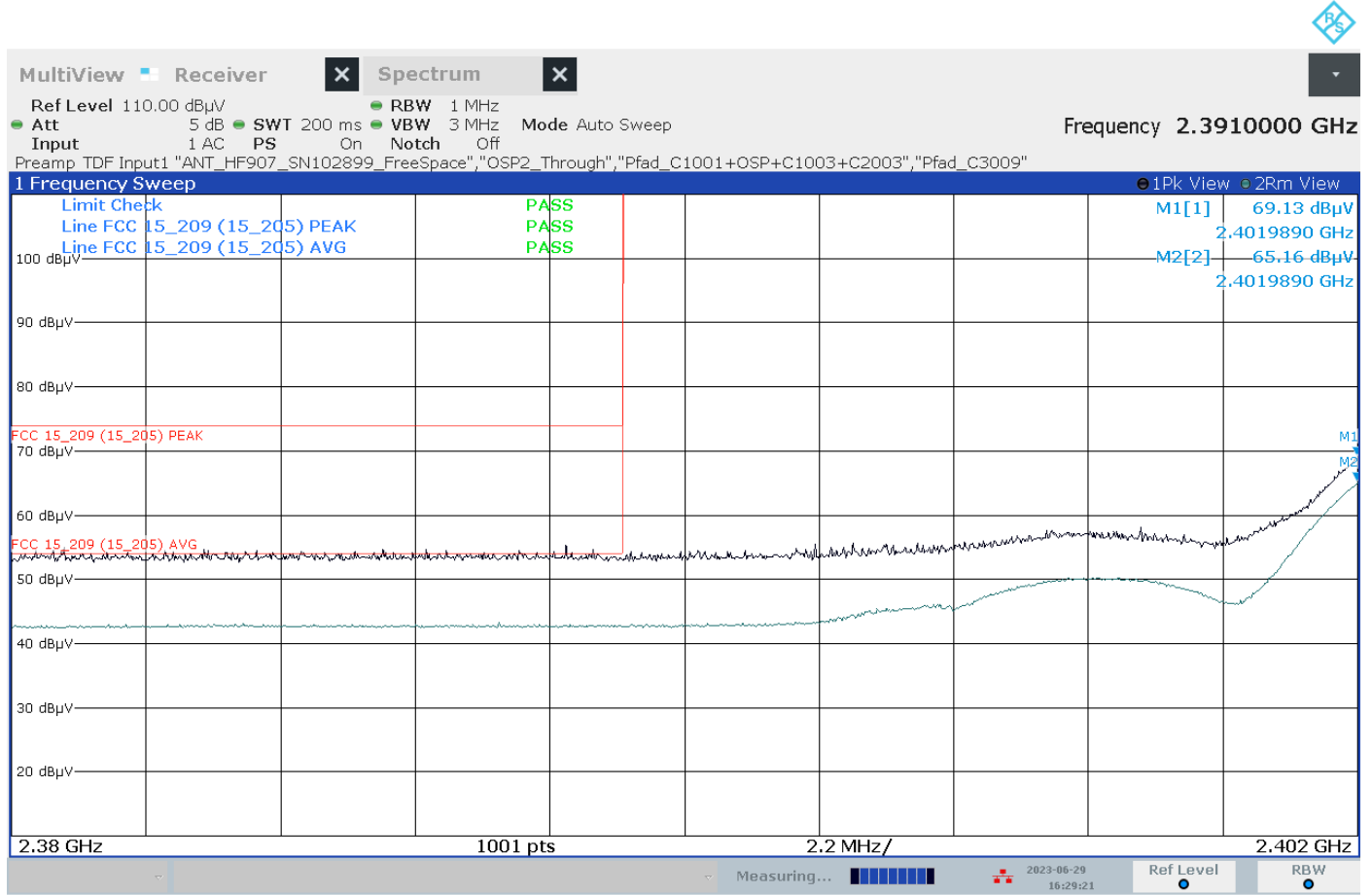

04:29:22 06/29/2023

Annex A of TR no.: 23038521-32373-2

14. Test: Band Edge Compliance (BEC), EUT No: 80, SN: R0047, Mode 2, g-mode, channel 1, 2412 MHz

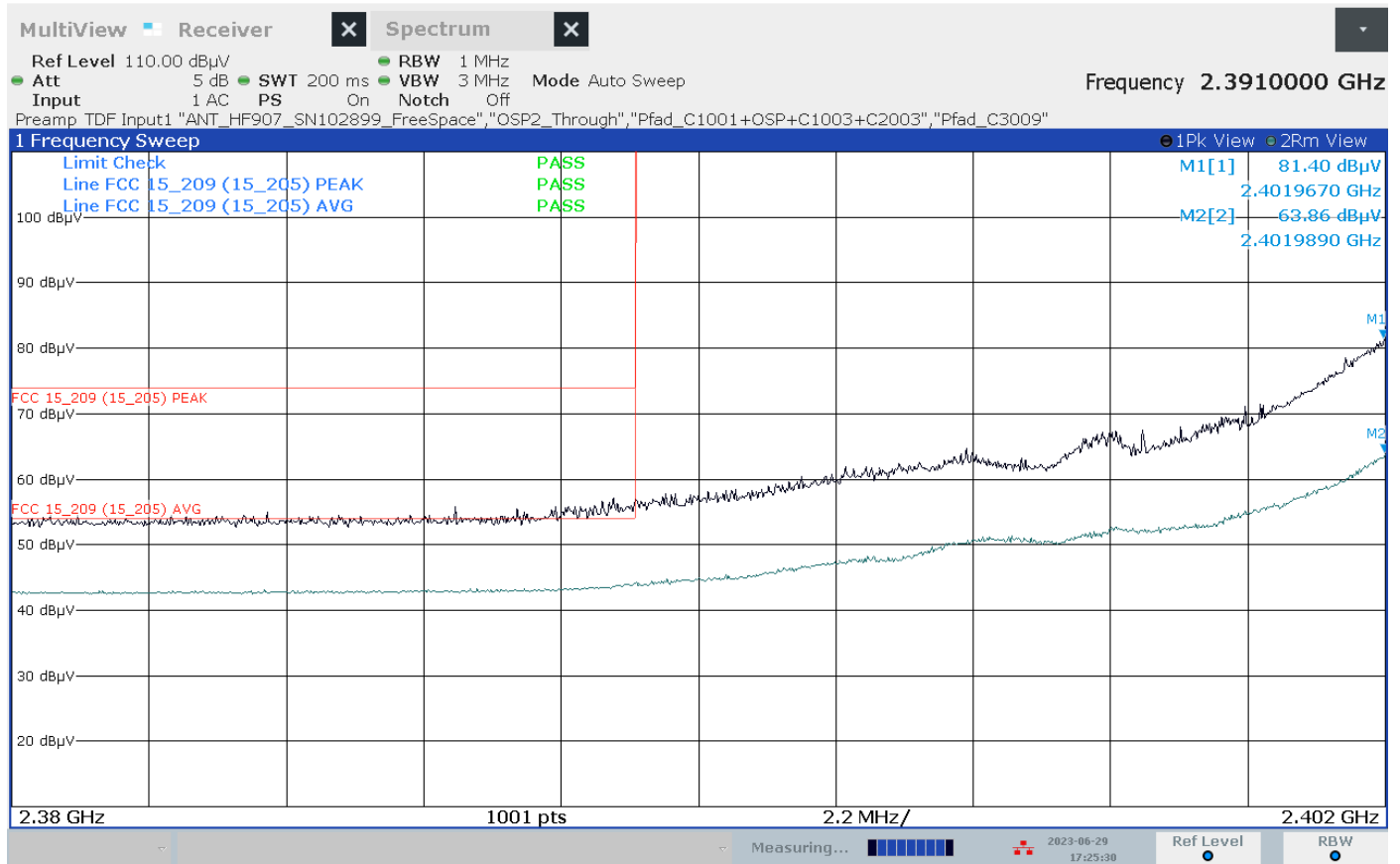

05:25:31 06/29/2023

Annex A of TR no.: 23038521-32373-2

15. Test: Band Edge Compliance (BEC), EUT No: 80, SN: R0047, Mode 3, n-HT20 mode, channel 1, 2412 MHz

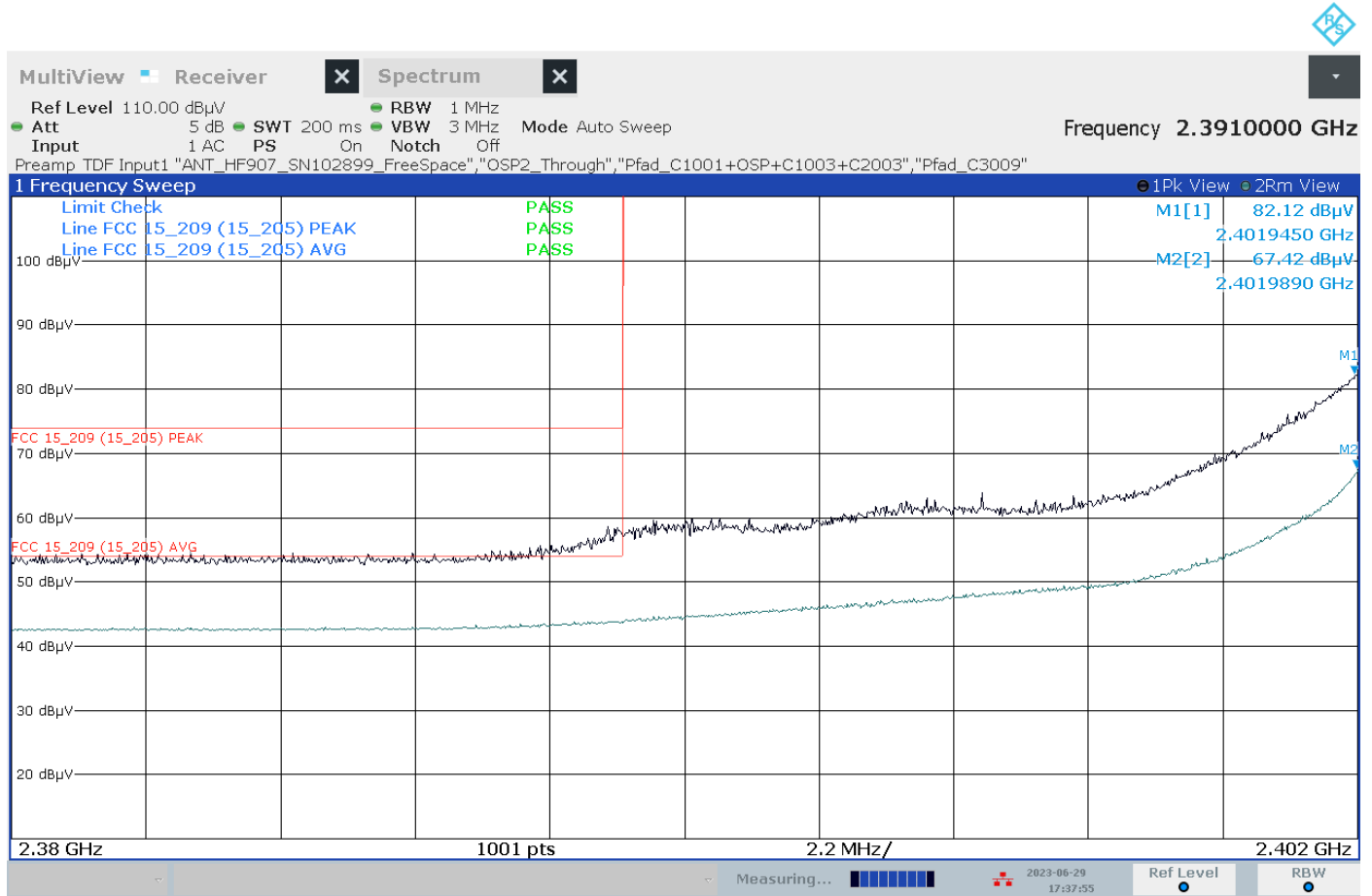

05:37:55 06/29/2023

Annex A of TR no.: 23038521-32373-2

16. Test: Band Edge Compliance (BEC), EUT No: 80, SN: R0047, Mode 1, b-mode, channel 13, 2472 MHz

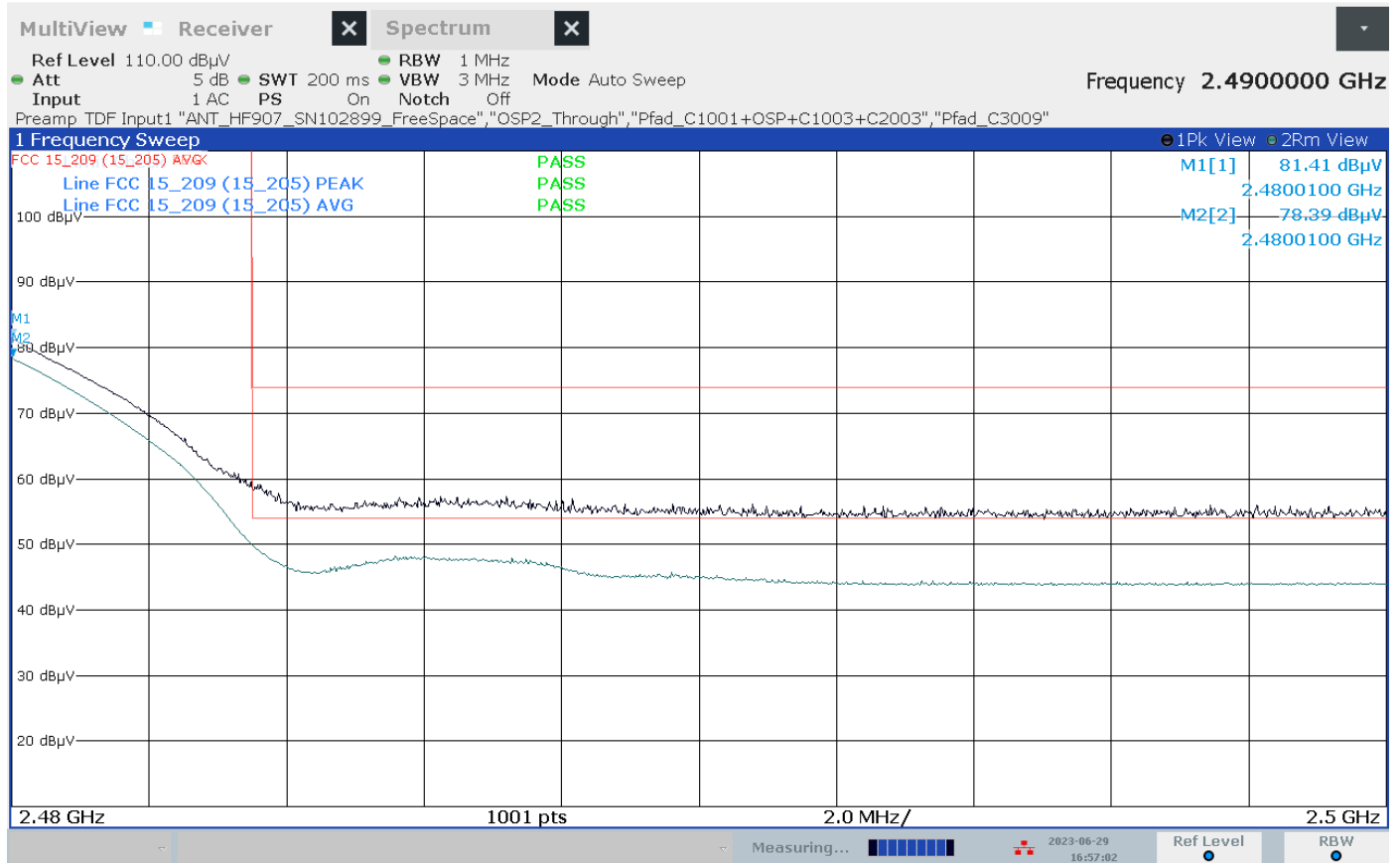

04:57:02 06/29/2023

17. Test: Band Edge Compliance (BEC), EUT No: 80, SN: R0047, Mode 2, g-mode, channel 13, 2472 MHz

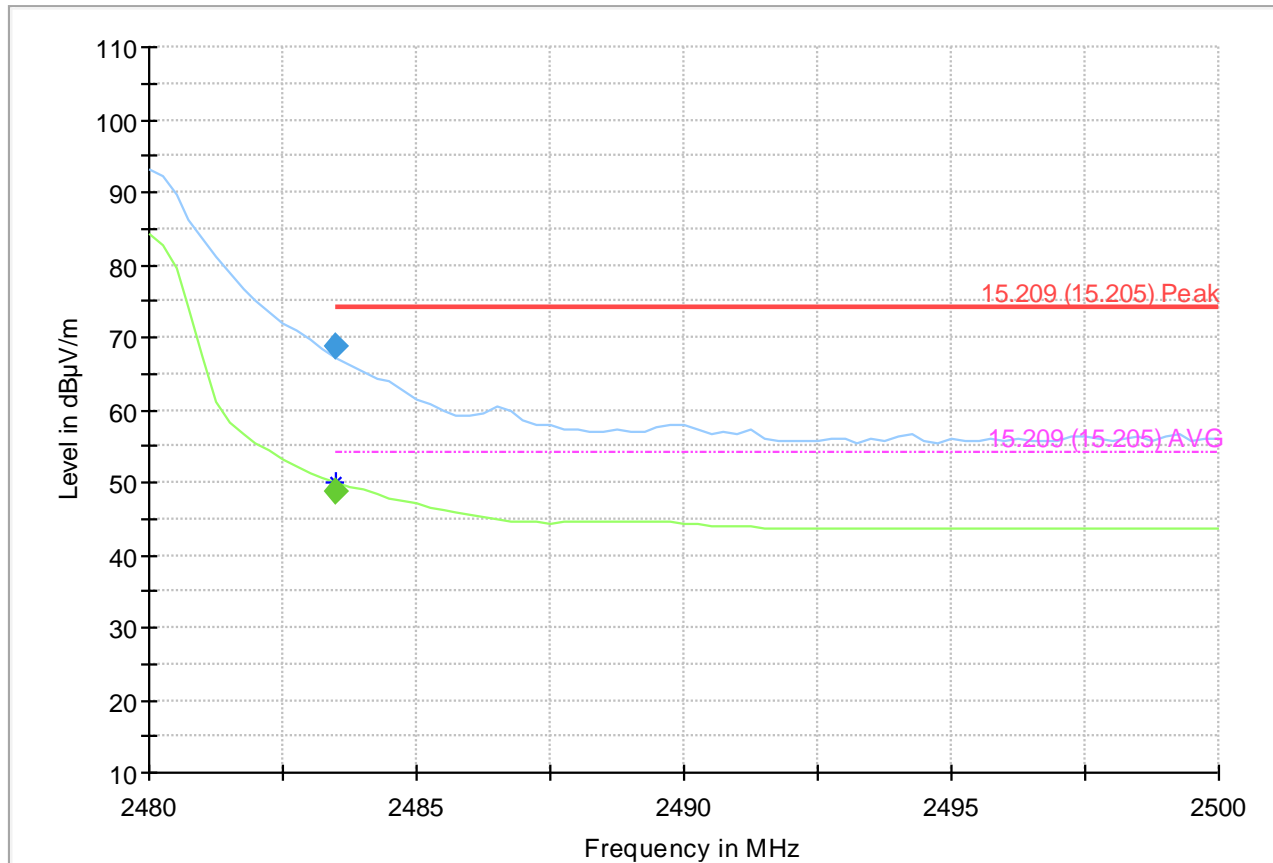

- Preview Result 2-AVG
- Preview Result 1-PK+
- 15.209 (15.205) Peak
- * Critical_Freqs AVG
- * Critical_Freqs PK+
- * Final_Result AVG
- ♦ Final_Result PK+
- - - 15.209 (15.205) AVG

Final_Result

Frequency (MHz)	MaxPeak (dBµV/m)	Average (dBµV/m)	Limit (dBµV/m)	Margin (dB)	Meas. Time (ms)	Bandwidth (kHz)	Height (cm)	Pol
2483.500000	---	48.80	54.00	5.20	100.0	1000.000	150.0	H
2483.500000	68.59	---	74.00	5.41	100.0	1000.000	150.0	H

18. Test: Band Edge Compliance (BEC), EUT No: 80, SN: R0047, Mode 3, n-HT20 mode, channel 13, 2472 MHz

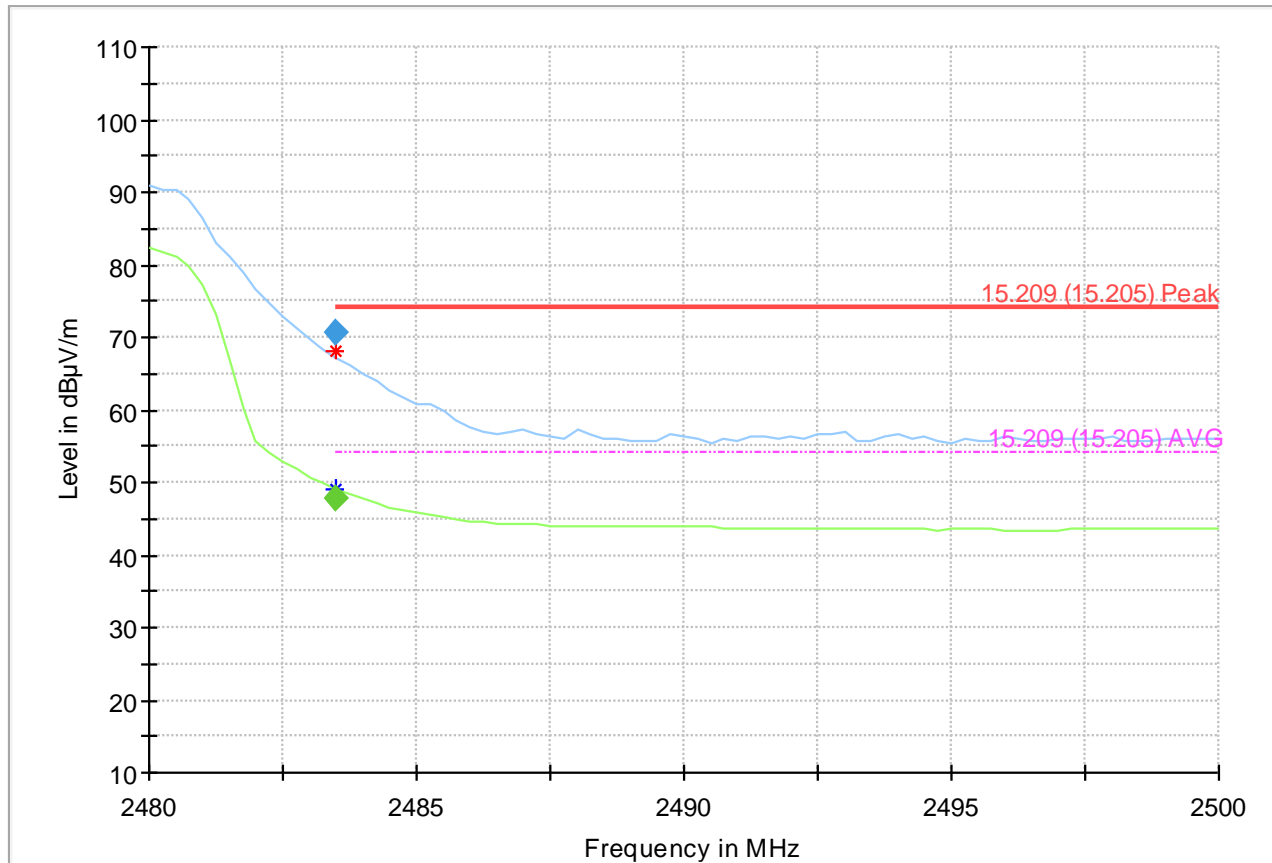

- Preview Result 2-AVG
- Preview Result 1-PK+
- * Critical_Freqs PK+
- 15.209 (15.205) Peak
- * Critical_Freqs AVG
- ◆ Final_Result PK+
- ◆ Final_Result AVG
- - - 15.209 (15.205) AVG

Final_Result

Frequency (MHz)	MaxPeak (dBµV/m)	Average (dBµV/m)	Limit (dBµV/m)	Margin (dB)	Meas. Time (ms)	Bandwidth (kHz)	Height (cm)	Pol
2483.500000	---	47.93	54.00	6.07	100.0	1000.000	150.0	H
2483.500000	70.50	---	74.00	3.51	100.0	1000.000	150.0	H

Radiated Spurious Emissions (RSE)

EUT No 79

19. Test: RSE 9 kHz - 30 MHz, EUT No: 79, SN: R0091, Mode 1, b-mode, channel 1, 2412 MHz

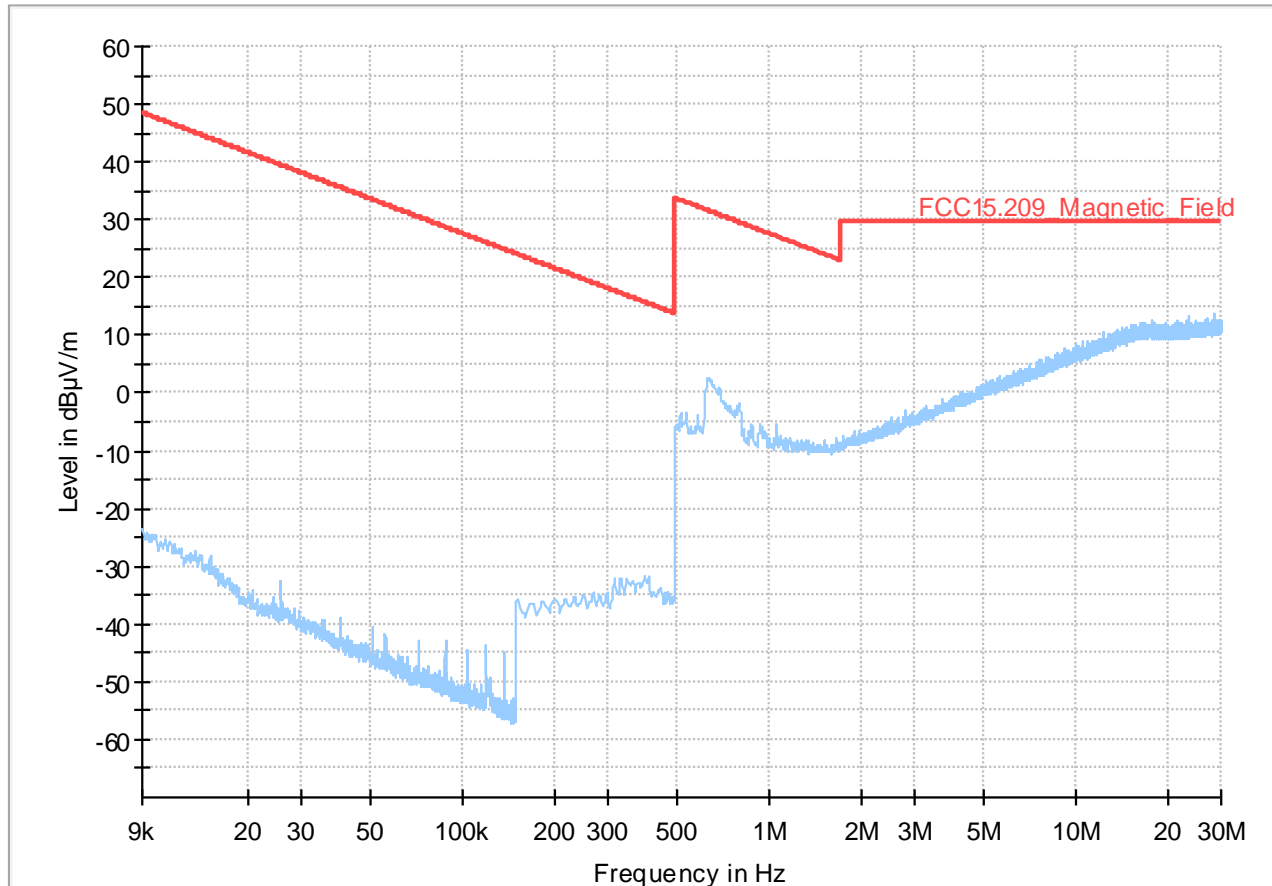

— Preview Result 1-PK+ * Critical_Freqs PK+
— FCC15.209_Magnetic_Field ◆ Final_Result QPK

Annex A of TR no.: 23038521-32373-2

20. Test: RSE 30 MHz - 1 GHz, EUT No: 79, SN: R0091, Mode 1, b-mode, channel 1, 2412 MHz

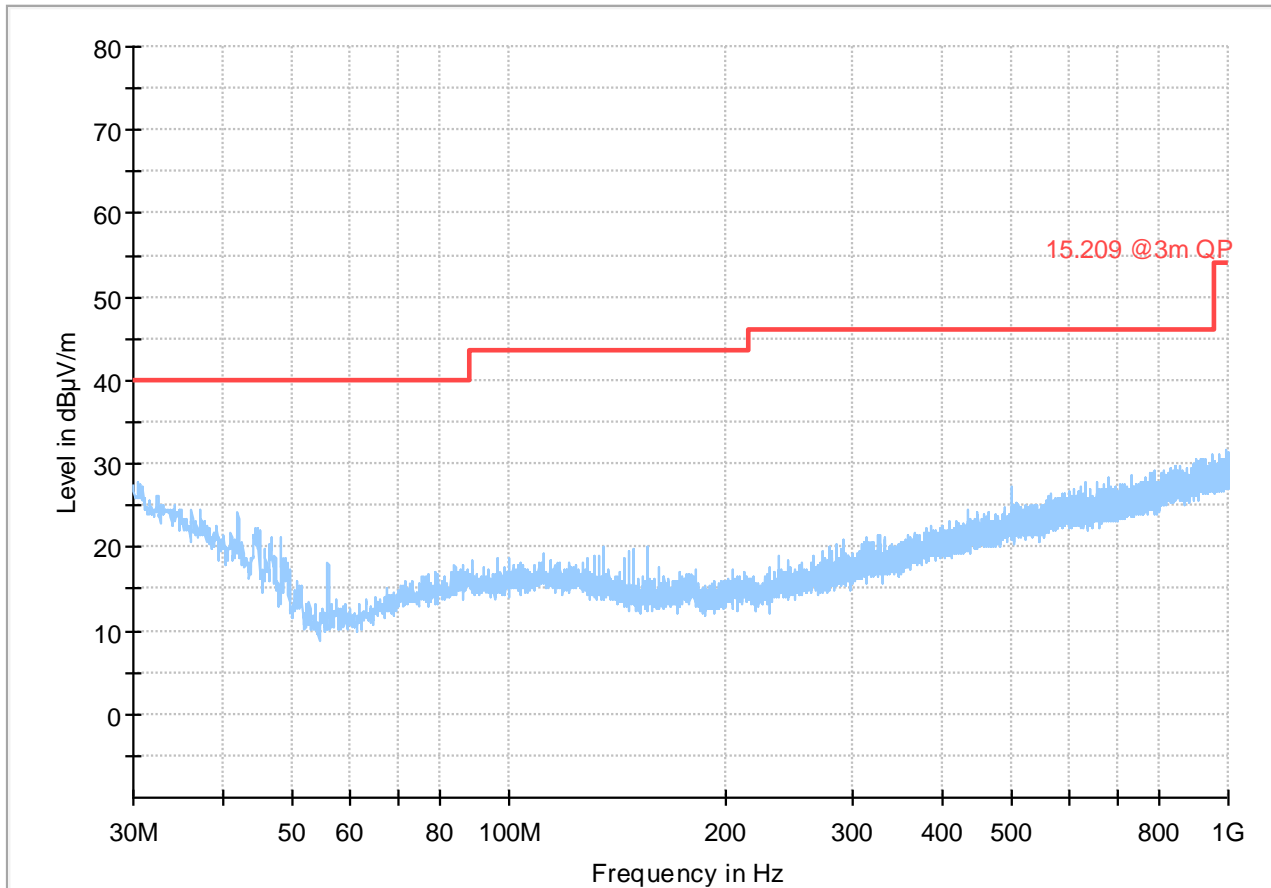

- Preview Result 1-PK+
- 15.209 @3m.QP
- * Critical_Freqs PK+
- ◆ Final_Result QPK

Annex A of TR no.: 23038521-32373-2

21. Test: RSE 9 kHz - 30 MHz, EUT No: 79, SN: R0091, Mode 1, b-mode, channel 13, 2472 MHz

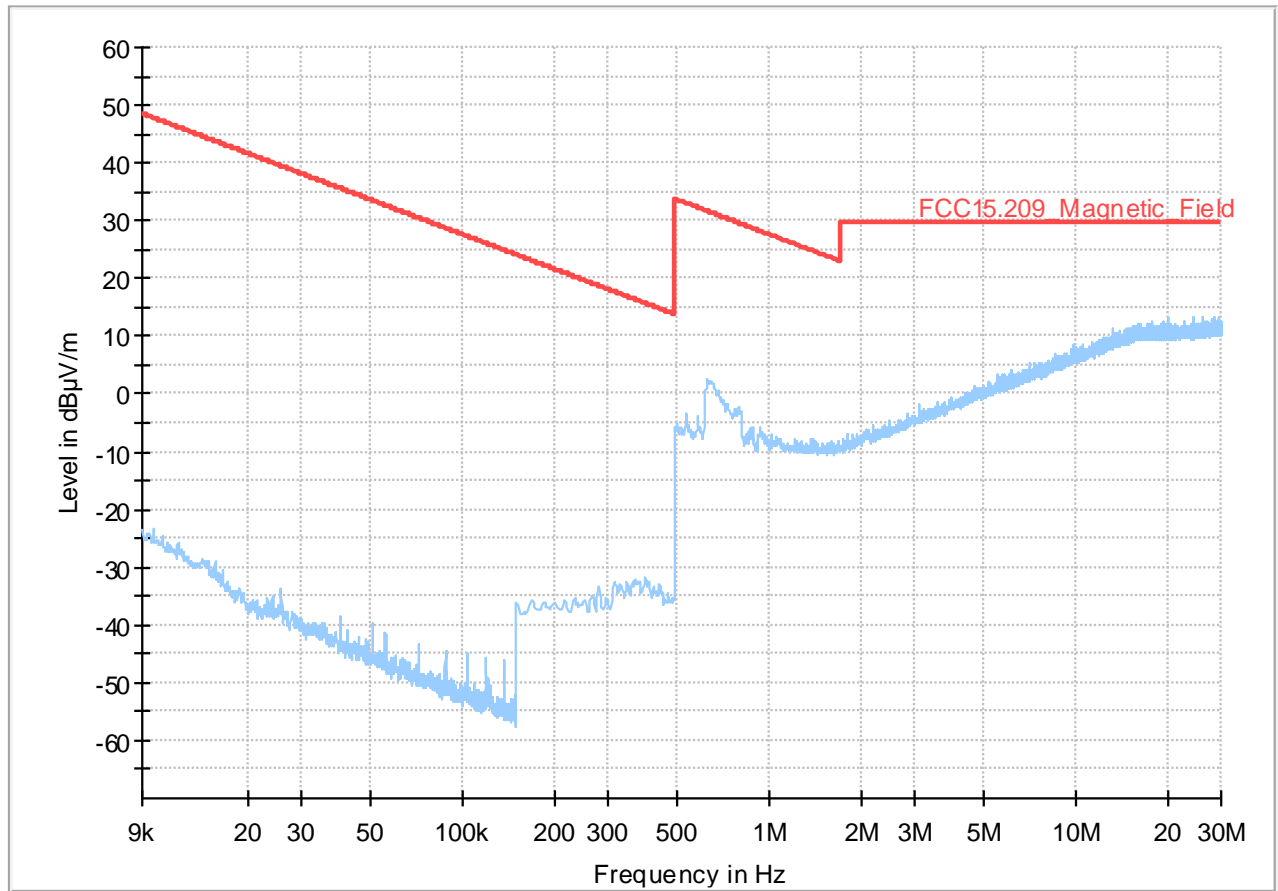

— Preview Result 1-PK+ * Critical_Freqs PK+
— FCC15.209_Magnetic_Field ◆ Final_Result QPK

Annex A of TR no.: 23038521-32373-2

22. Test: RSE 30 MHz - 1 GHz, EUT No: 79, SN: R0091, Mode 1, b-mode, channel 1, 2472 MHz

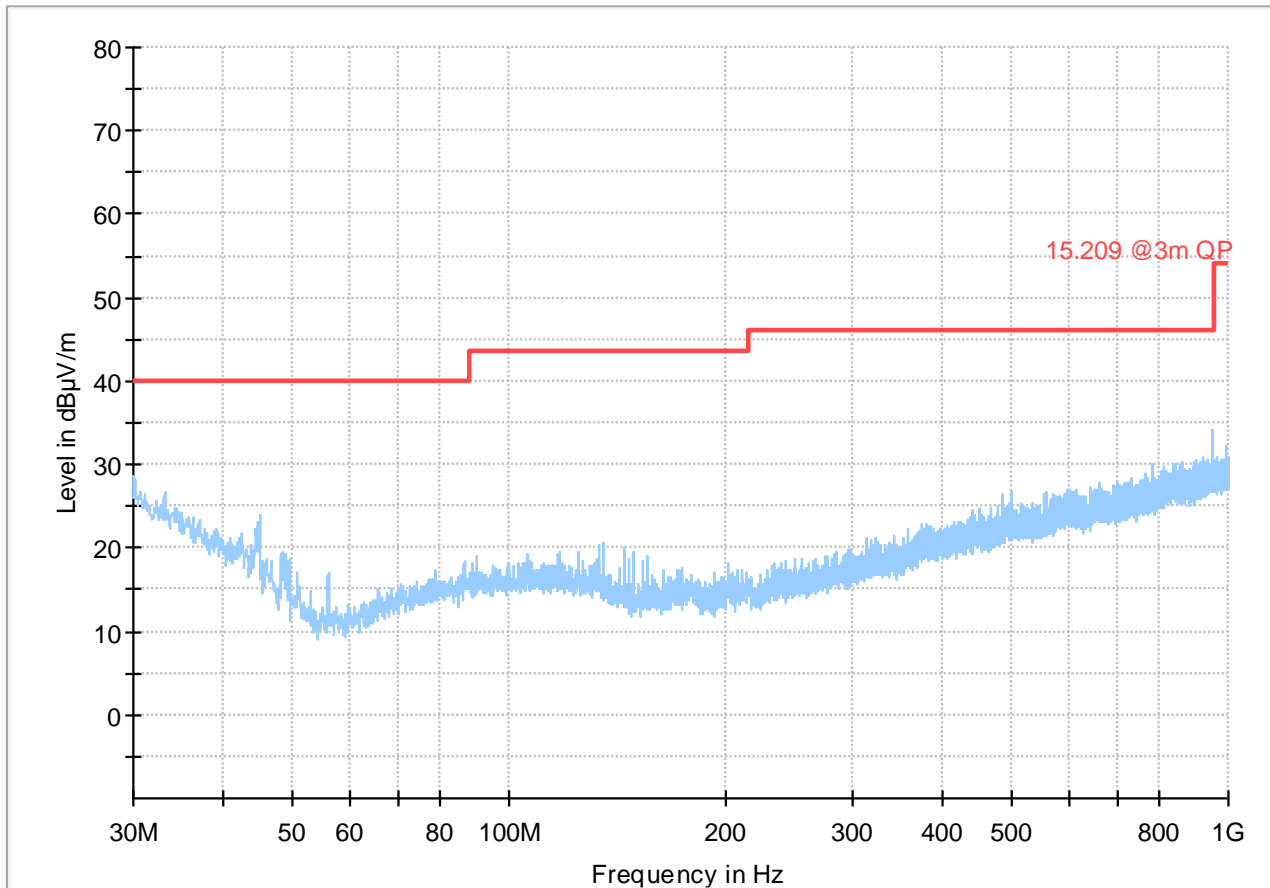

— Preview Result 1-PK+ * Critical_Freqs PK+
— 15.209 @3m QP ◆ Final_Result QPK

Annex A of TR no.: 23038521-32373-2

23. Test: RSE 1 GHz - 3 GHz, EUT No: 79, SN: R0091, Mode 1, b-mode, channel 1, 2412 MHz

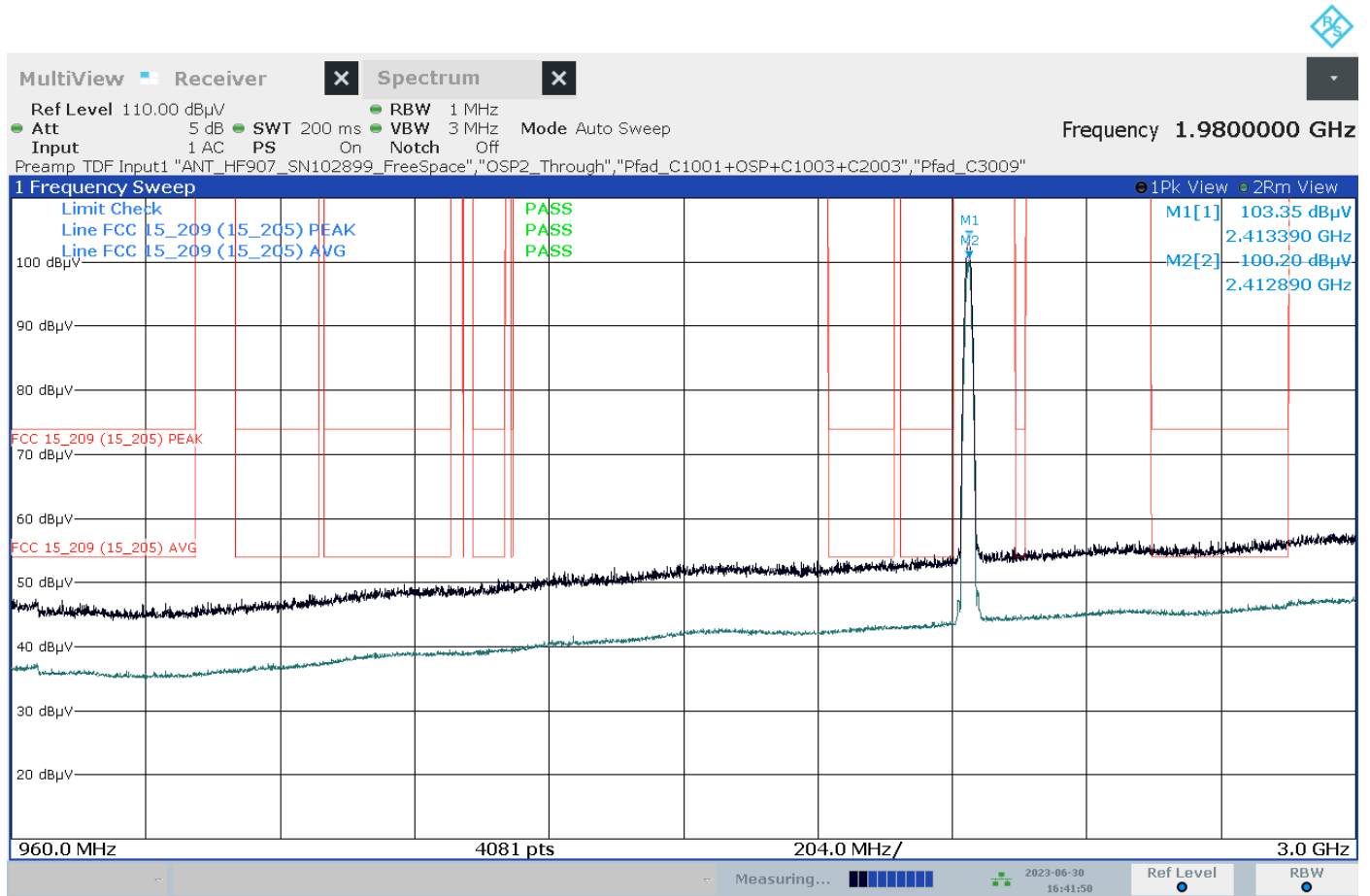

Annex A of TR no.: 23038521-32373-2

24. Test: RSE 3 GHz - 9 GHz, EUT No: 79, SN: R0091, Mode 1, b-mode, channel 1, 2412 MHz

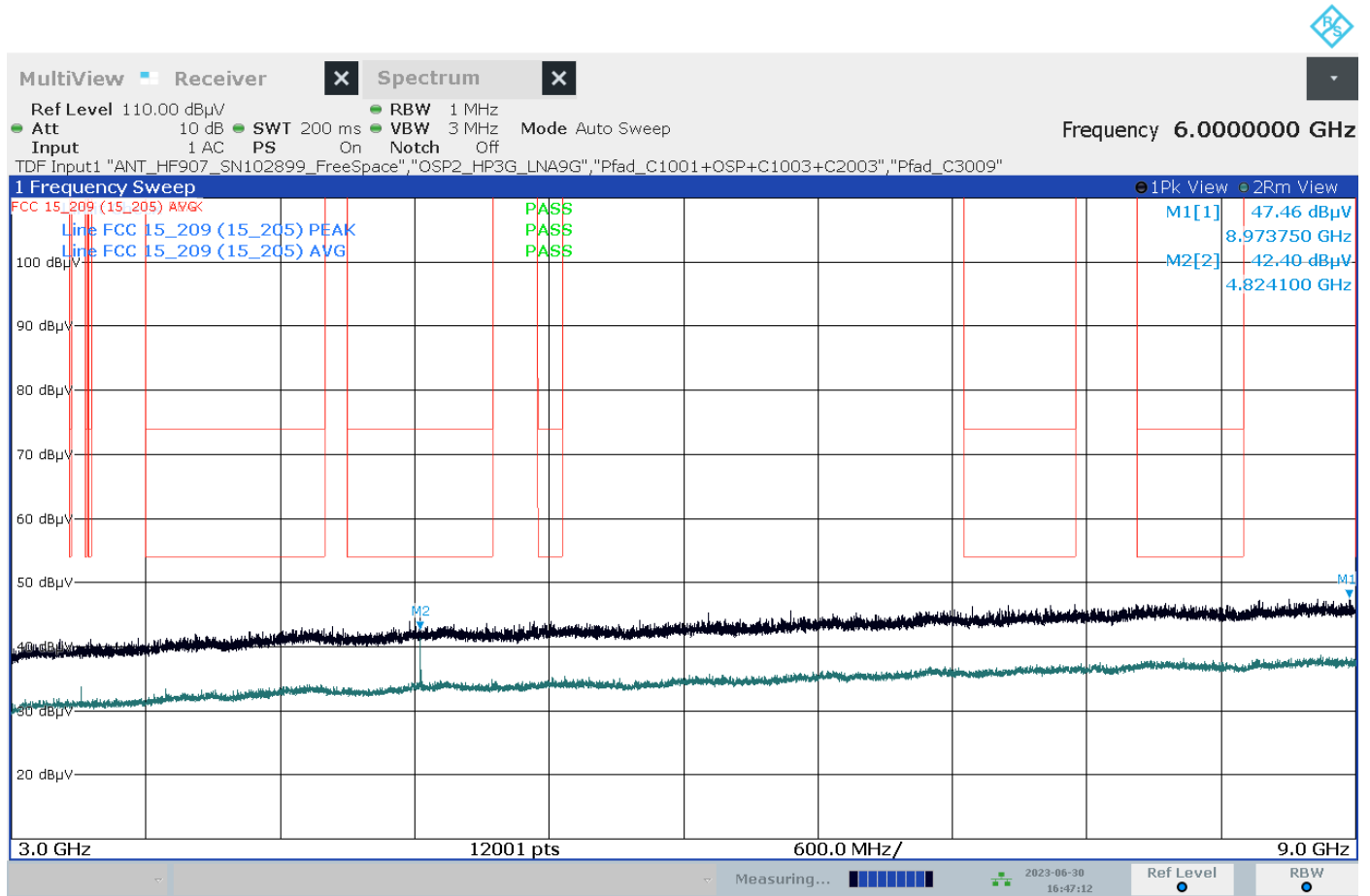

04:47:13 06/30/2023

Annex A of TR no.: 23038521-32373-2

25. Test: RSE 9 GHz - 18 GHz, EUT No: 79, SN: R0091, Mode 1, b-mode, channel 1, 2412 MHz

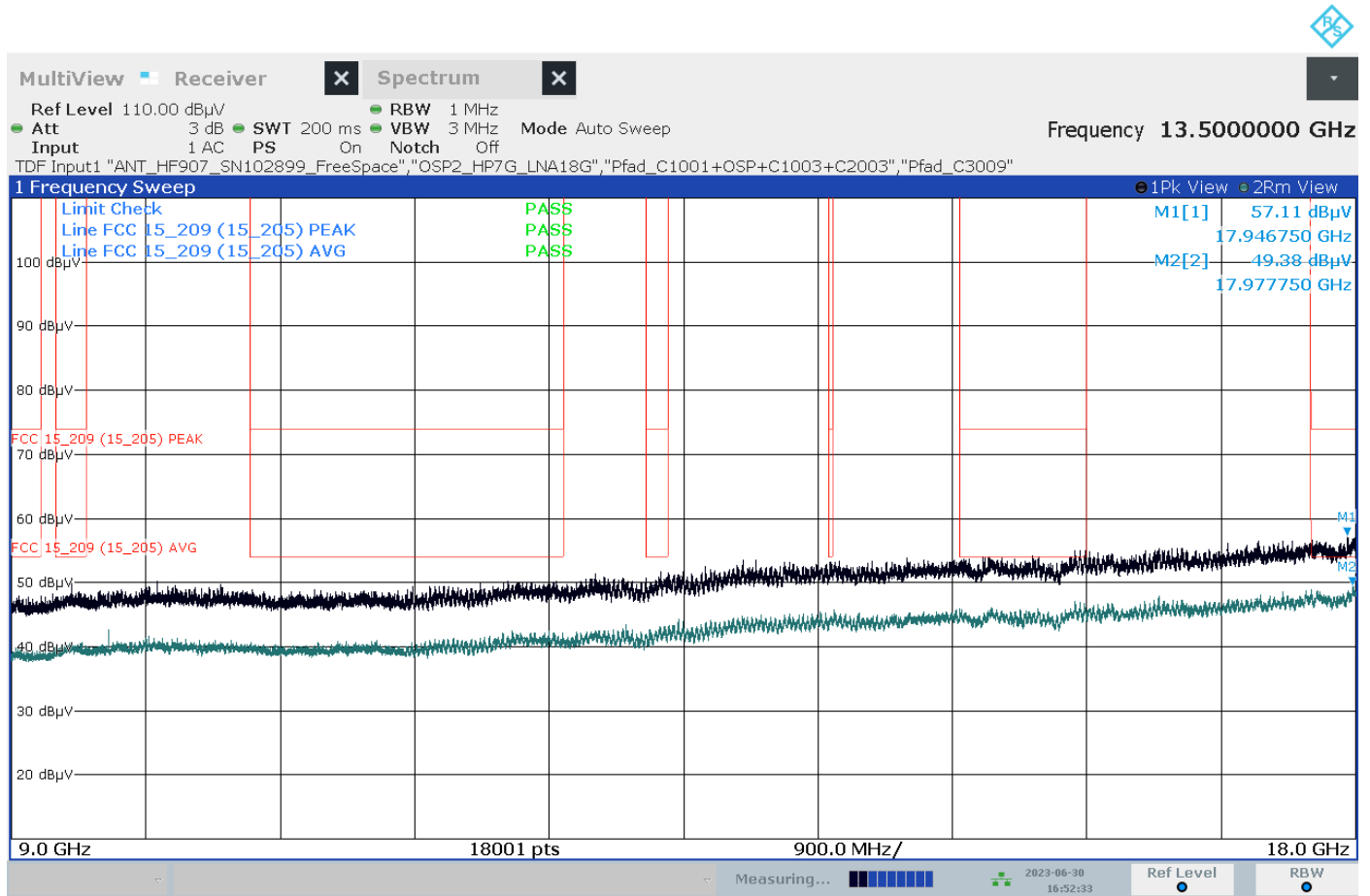

04:52:34 06/30/2023

Annex A of TR no.: 23038521-32373-2

26. Test: RSE 18 GHz - 26.5 GHz, EUT No: 79, SN: R0091, Mode 1, b-mode, channel 1, 2412 MHz

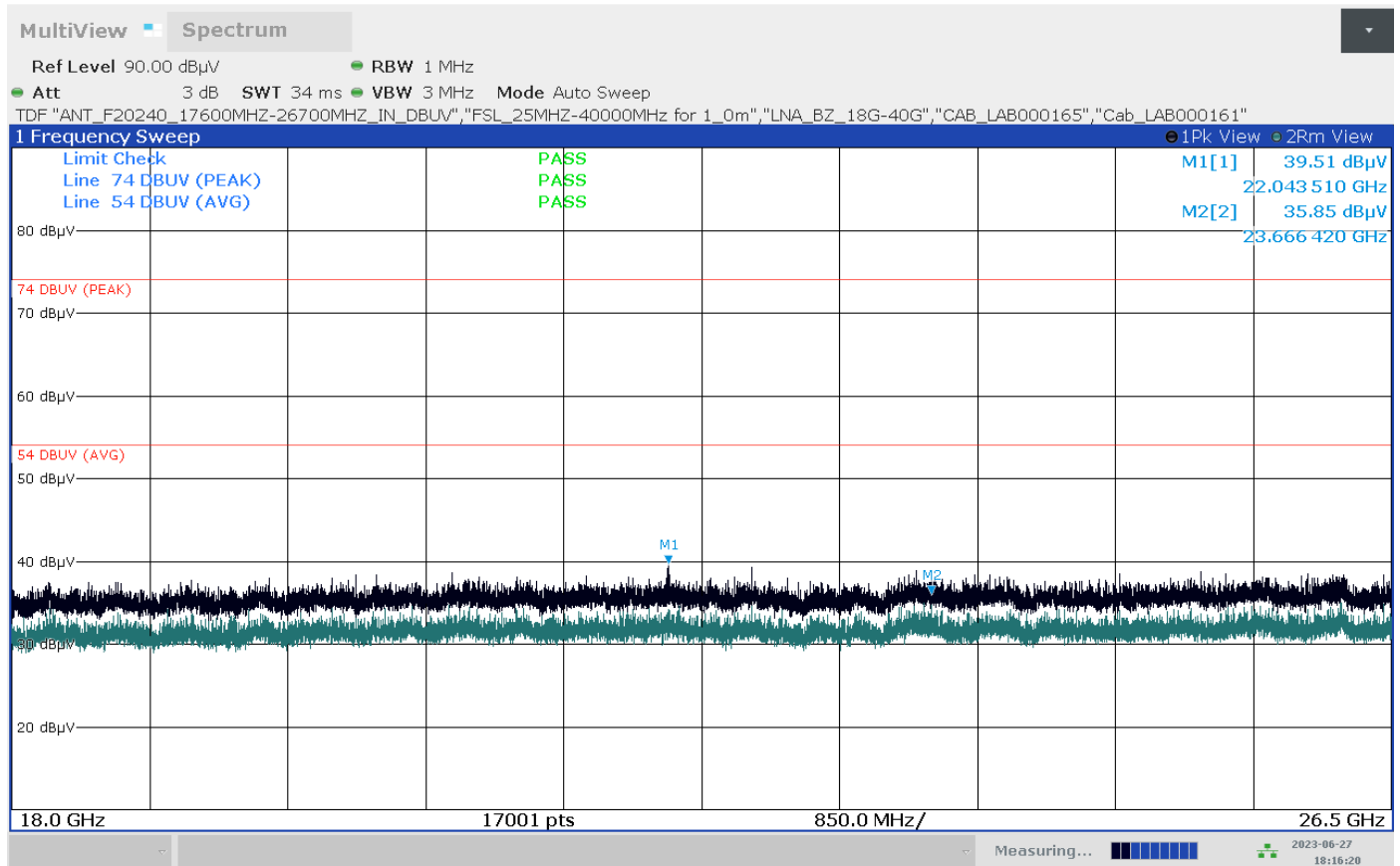

06:16:20 06/27/2023

Annex A of TR no.: 23038521-32373-2

27. Test: RSE 1 GHz - 3 GHz, EUT No: 79, SN: R0091, Mode 1, b-mode, channel 13, 2472 MHz

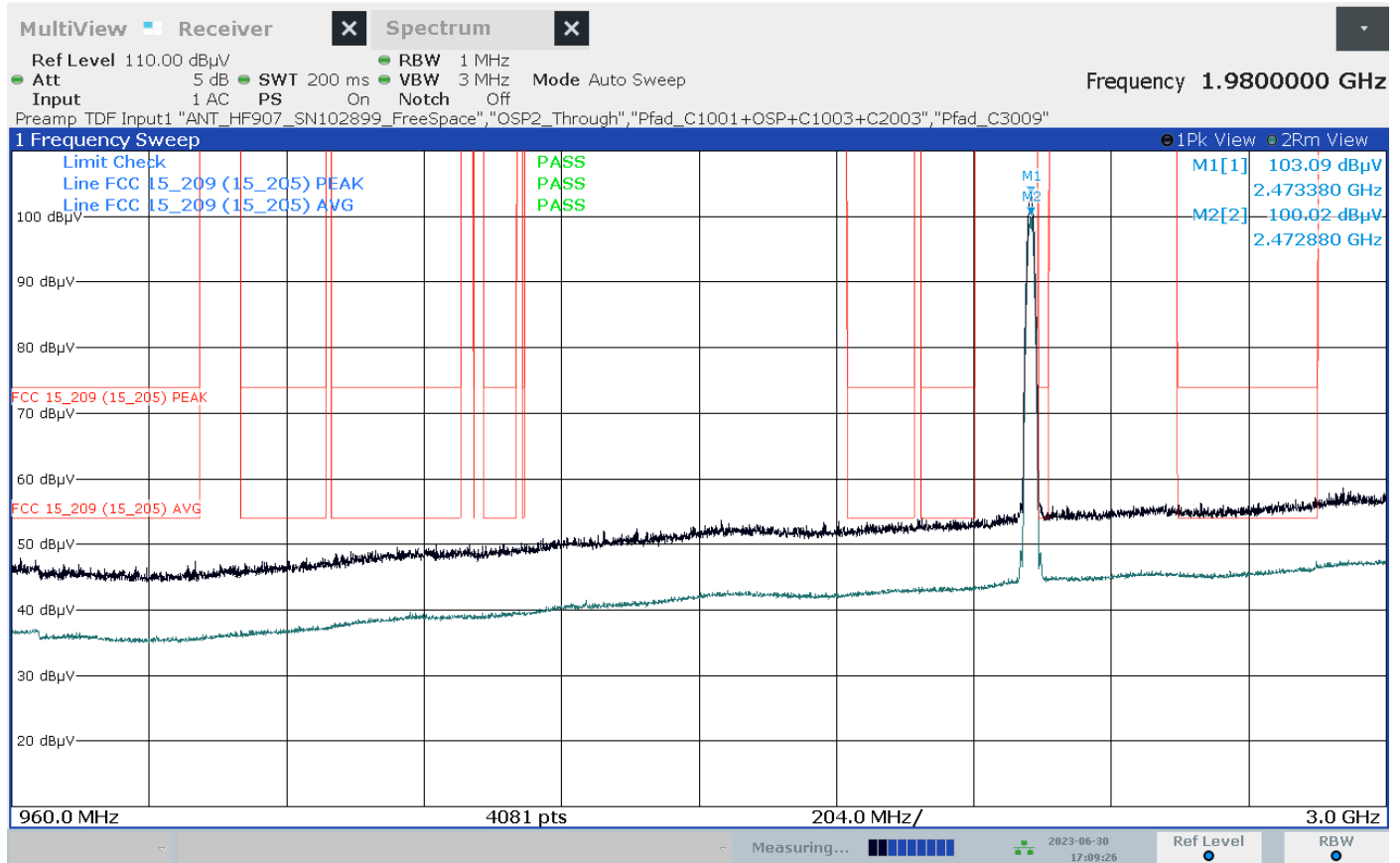

05:09:27 06/30/2023

Annex A of TR no.: 23038521-32373-2

28. Test: RSE 3 GHz - 9 GHz, EUT No: 79, SN: R0091, Mode 1, b-mode, channel 13, 2472 MHz

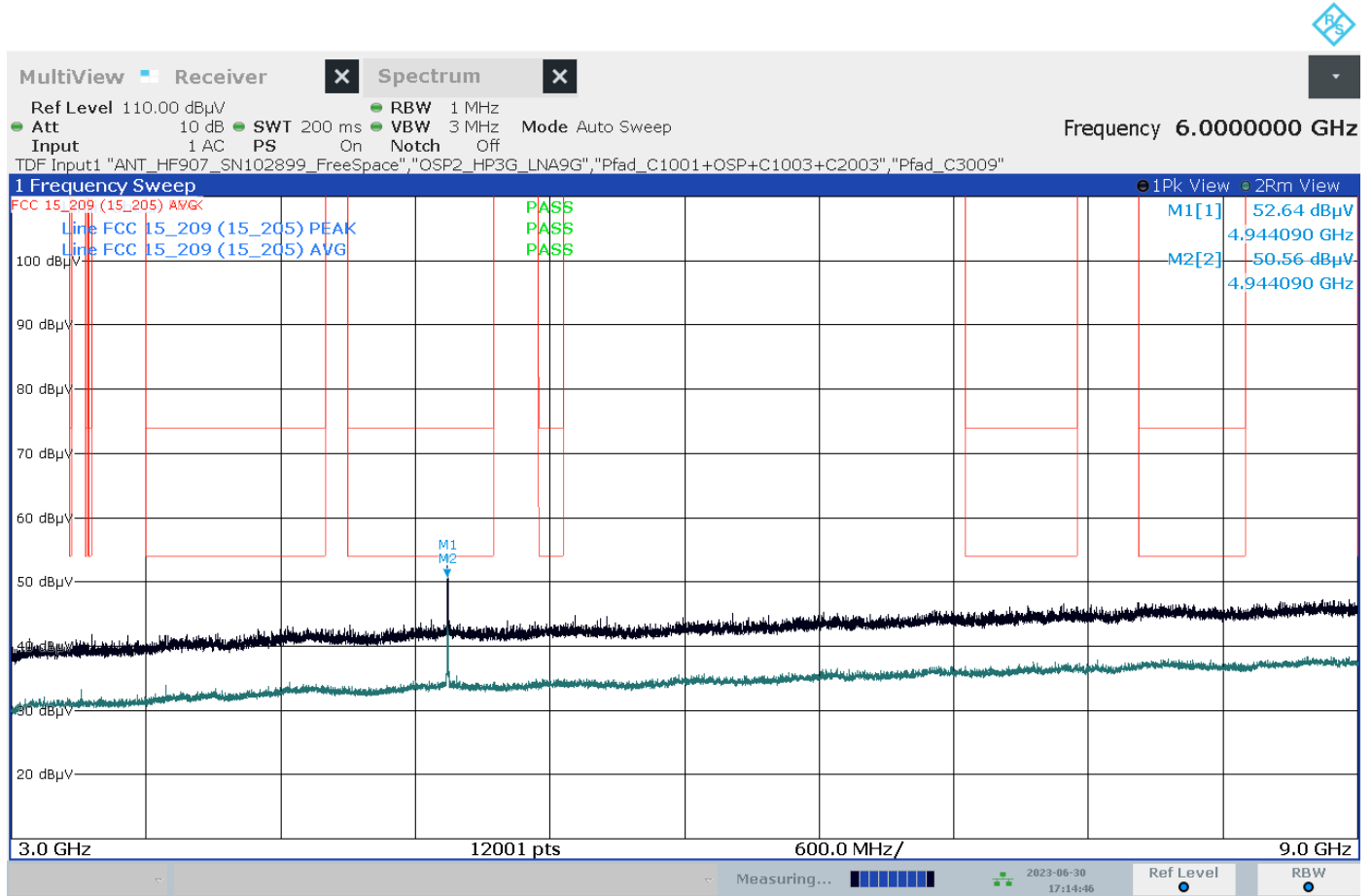

05:14:48 06/30/2023

Annex A of TR no.: 23038521-32373-2

29. Test: RSE 9 GHz - 18 GHz, EUT No: 79, SN: R0091, Mode 1, b-mode, channel 13, 2472 MHz

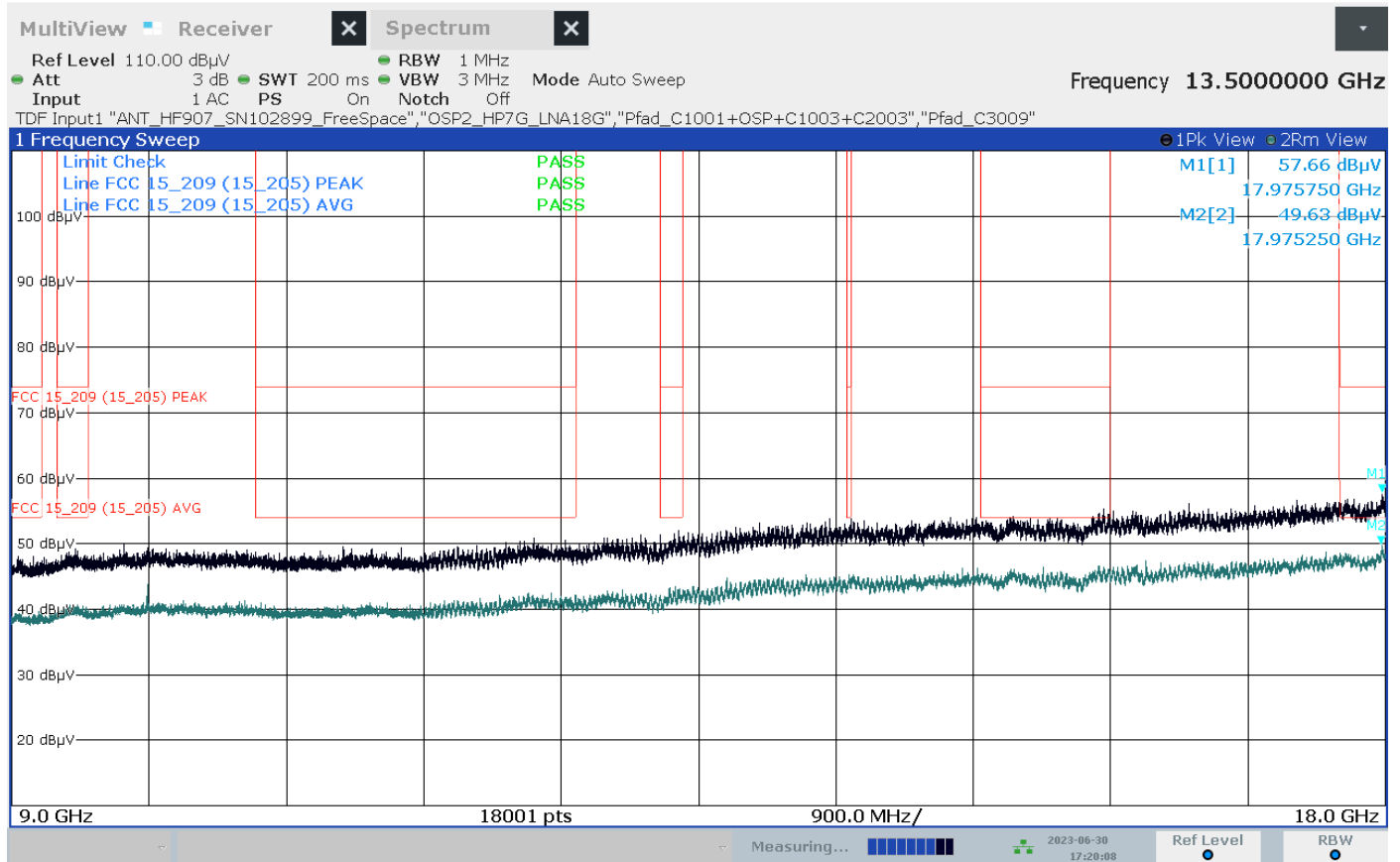

05:20:10 06/30/2023

Annex A of TR no.: 23038521-32373-2

30. Test: RSE 18 GHz - 26.5 GHz, EUT No: 79, SN: R0091, Mode 1, b-mode, channel 13, 2472 MHz

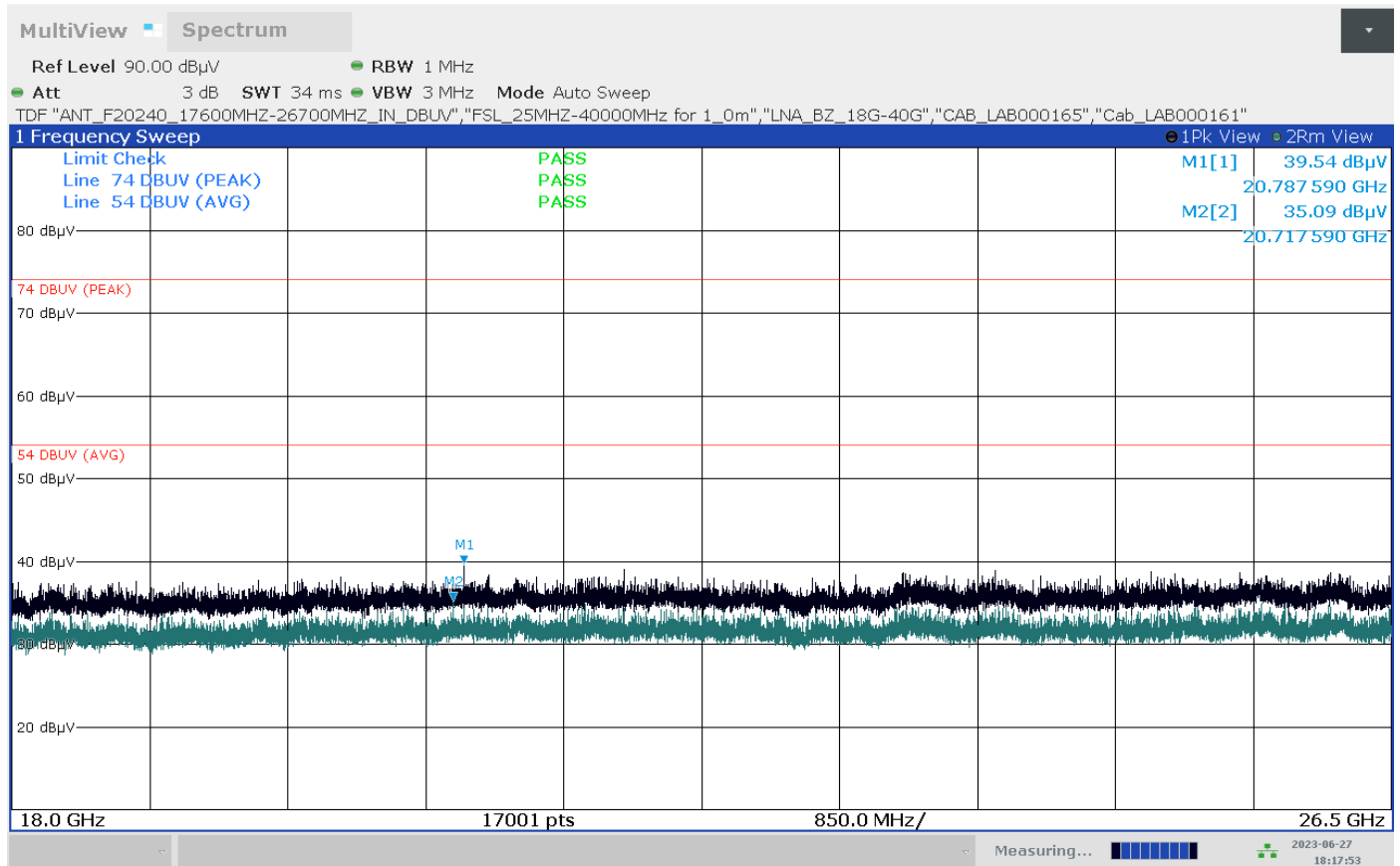

06:17:54 06/27/2023

EUT No 80

31. Test: RSE 9 kHz - 30 MHz, EUT No: 80, SN: R0047, Mode 1, b-mode, channel 1, 2412 MHz

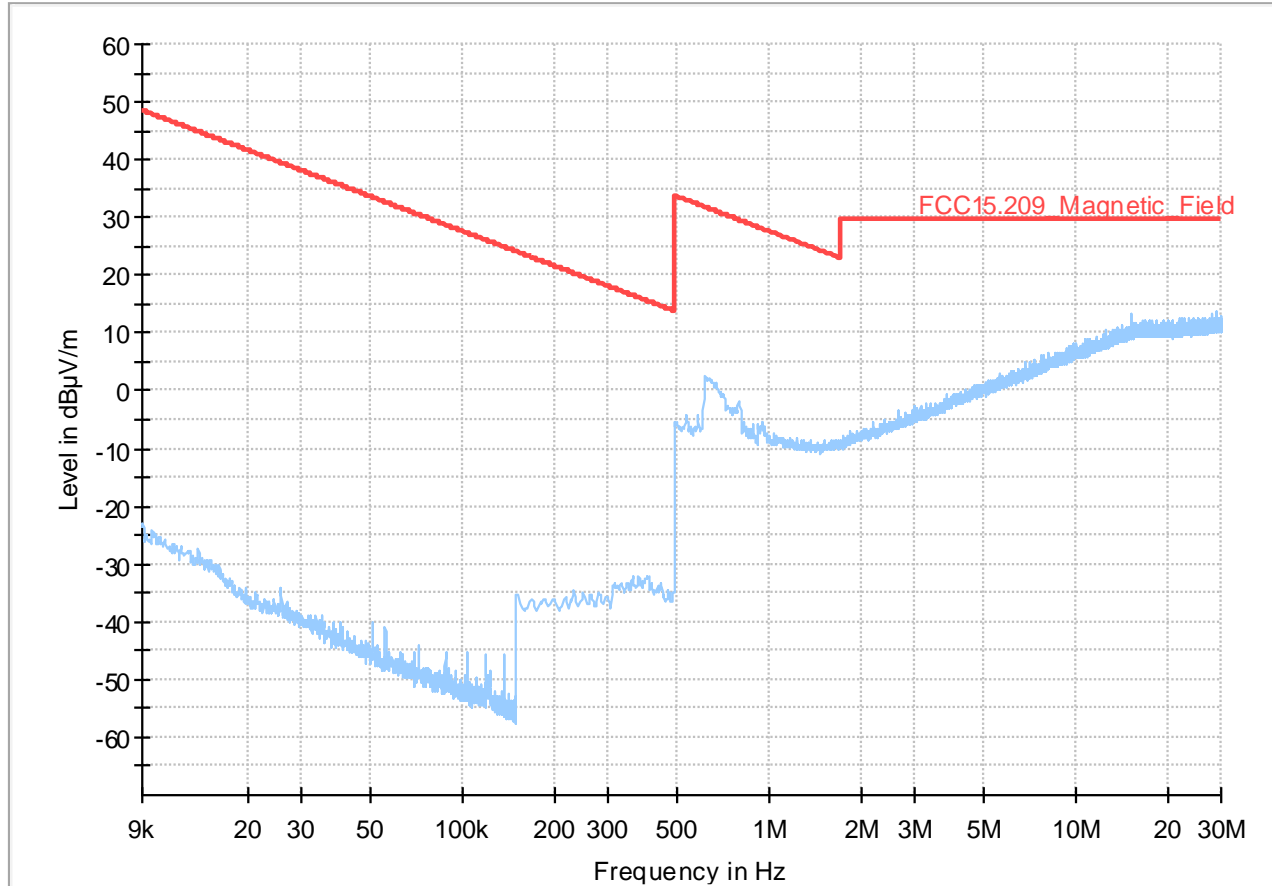

- Preview Result 1-PK+
- FCC15.209_Magnetic_Field
- * Critical_Freqs PK+
- ◆ Final_Result QPK

Annex A of TR no.: 23038521-32373-2

32. Test: RSE 30 MHz - 1 GHz, EUT No: 80, SN: R0047, Mode 1, b-mode, channel 1, 2412 MHz

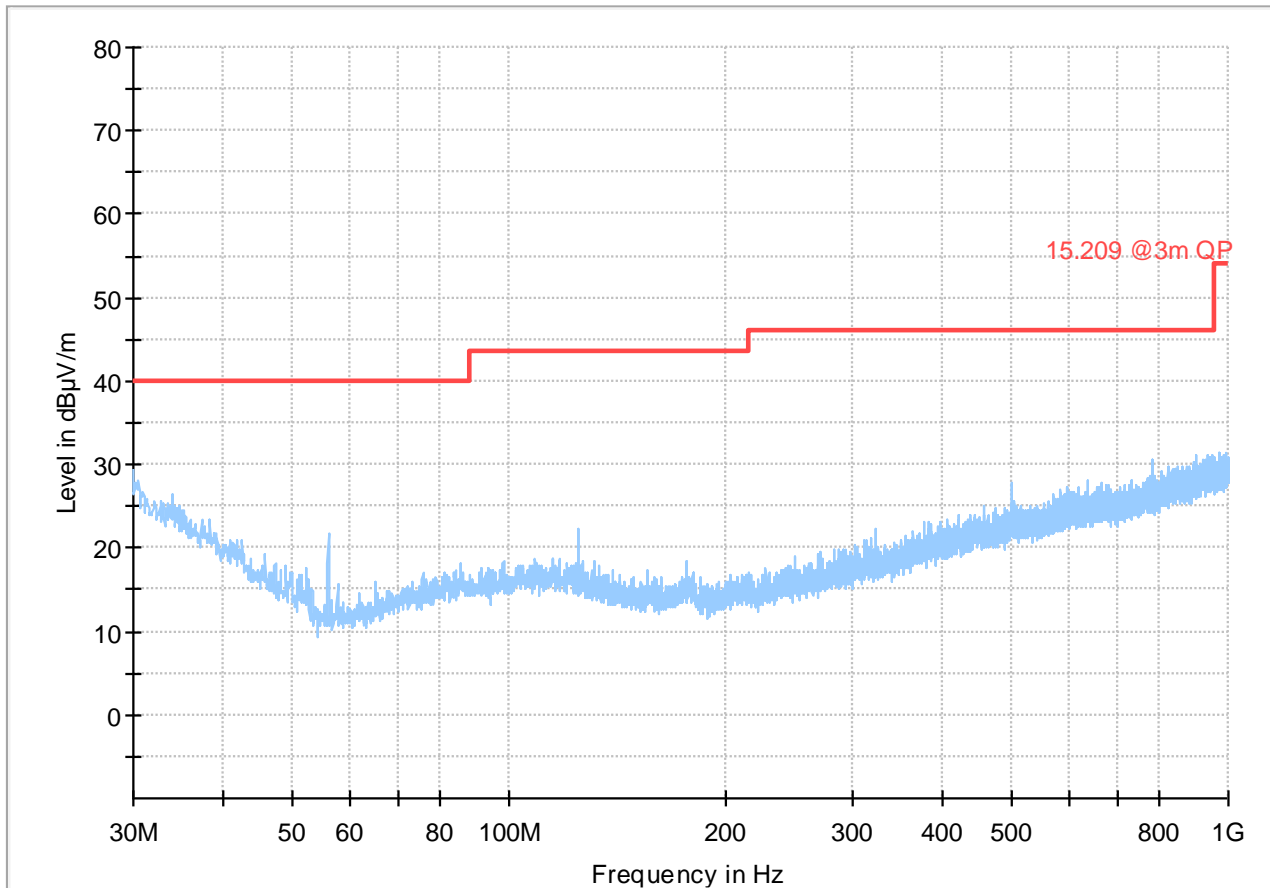

— Preview Result 1-PK+ * Critical_Freqs PK+
— 15.209 @3m QP ◆ Final_Result QPK

Annex A of TR no.: 23038521-32373-2

33. Test: RSE 9 kHz - 30 MHz, EUT No: 80, SN: R0047, Mode 1, b-mode, channel 13, 2472 MHz

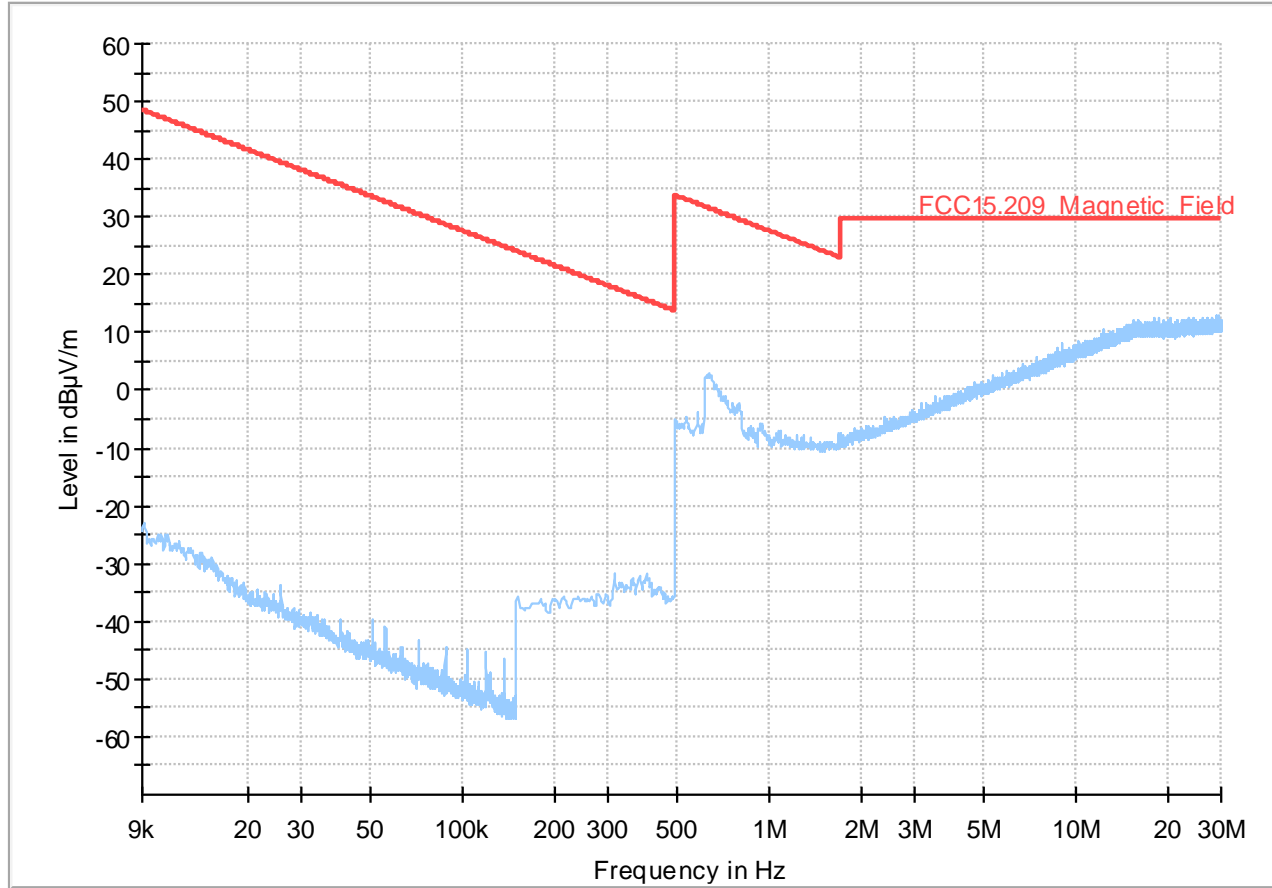

— Preview Result 1-PK+ * Critical_Freqs PK+
— FCC15.209_Magnetic_Field ◆ Final_Result QPK

Annex A of TR no.: 23038521-32373-2

34. Test: RSE 30 MHz - 1 GHz, EUT No: 80, SN: R0047, Mode 1, b-mode, channel 1, 2472 MHz

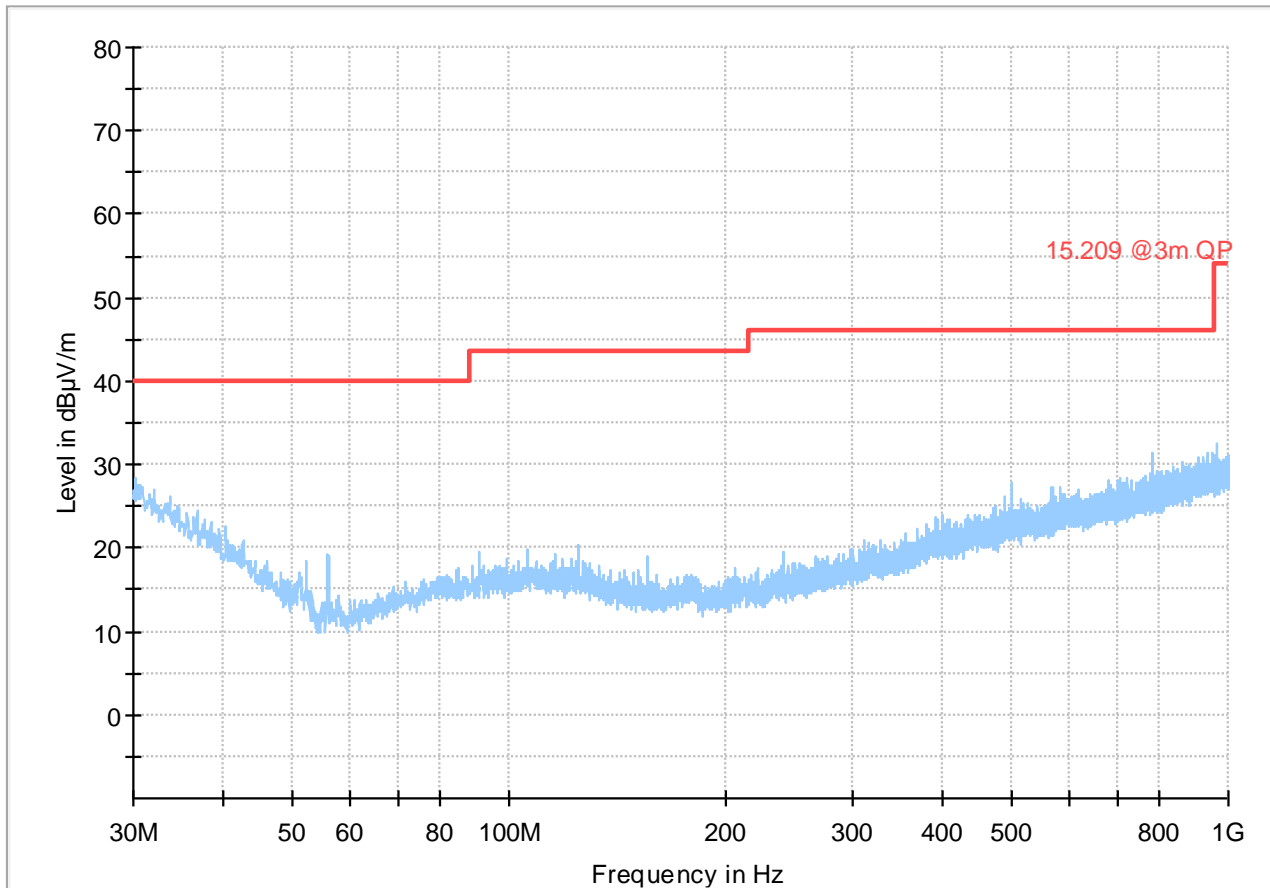

— Preview Result 1-PK+ * Critical_Freqs PK+
— 15.209 @3m QP ◆ Final_Result QPK

Annex A of TR no.: 23038521-32373-2

35. Test: RSE 1 GHz - 3 GHz, EUT No: 80, SN: R0047, Mode 1, b-mode, channel 1, 2412 MHz

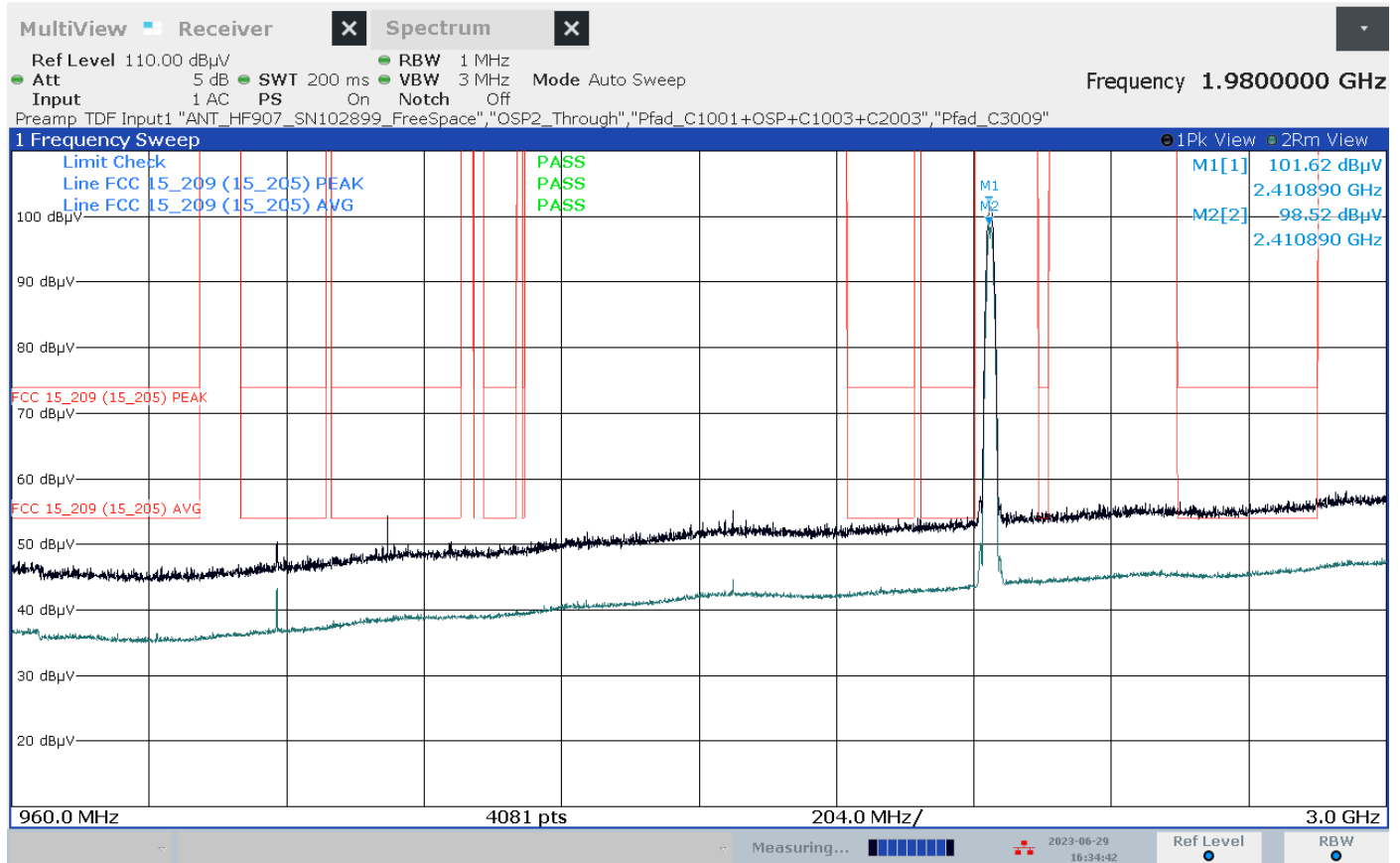

04:34:42 06/29/2023

Annex A of TR no.: 23038521-32373-2

36. Test: RSE 3 GHz - 9 GHz, EUT No: 80, SN: R0047, Mode 1, b-mode, channel 1, 2412 MHz

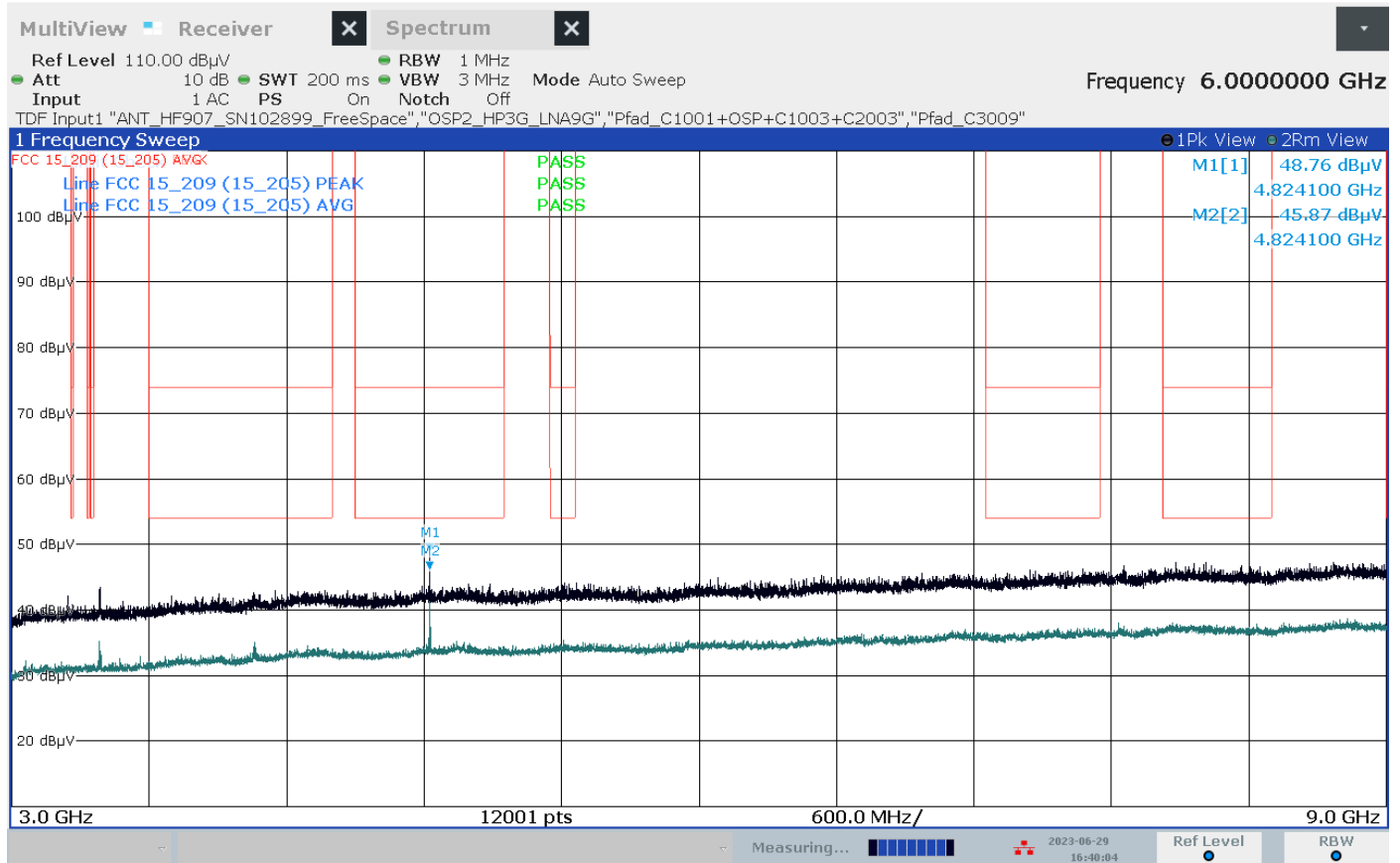

04:40:04 06/29/2023

Annex A of TR no.: 23038521-32373-2

37. Test: RSE 9 GHz - 18 GHz, EUT No: 80, SN: R0047, Mode 1, b-mode, channel 1, 2412 MHz

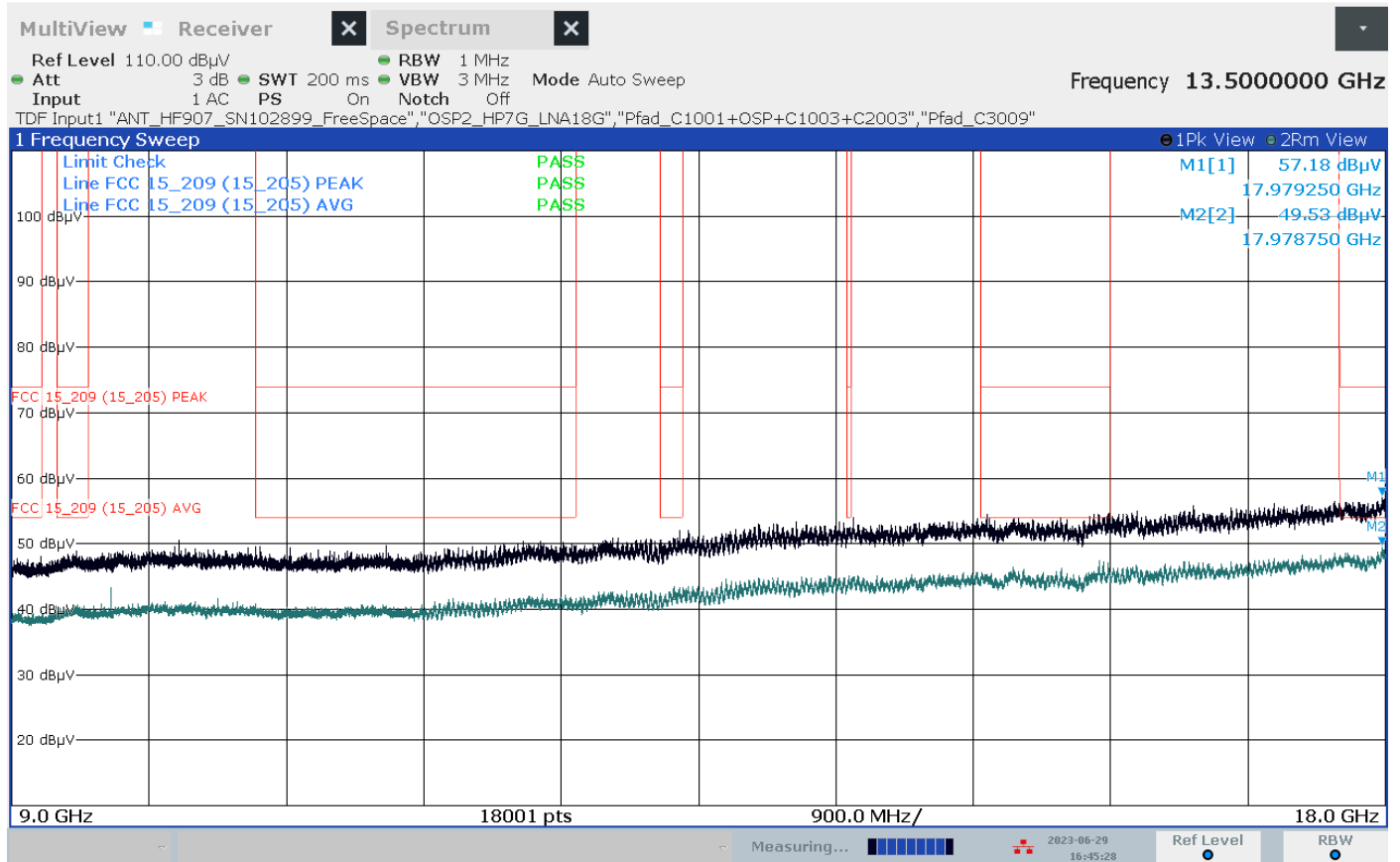

04:45:29 06/29/2023

Annex A of TR no.: 23038521-32373-2

38. Test: RSE 18 GHz - 26.5 GHz, EUT No: 80, SN: R0047, Mode 1, b-mode, channel 1, 2412 MHz

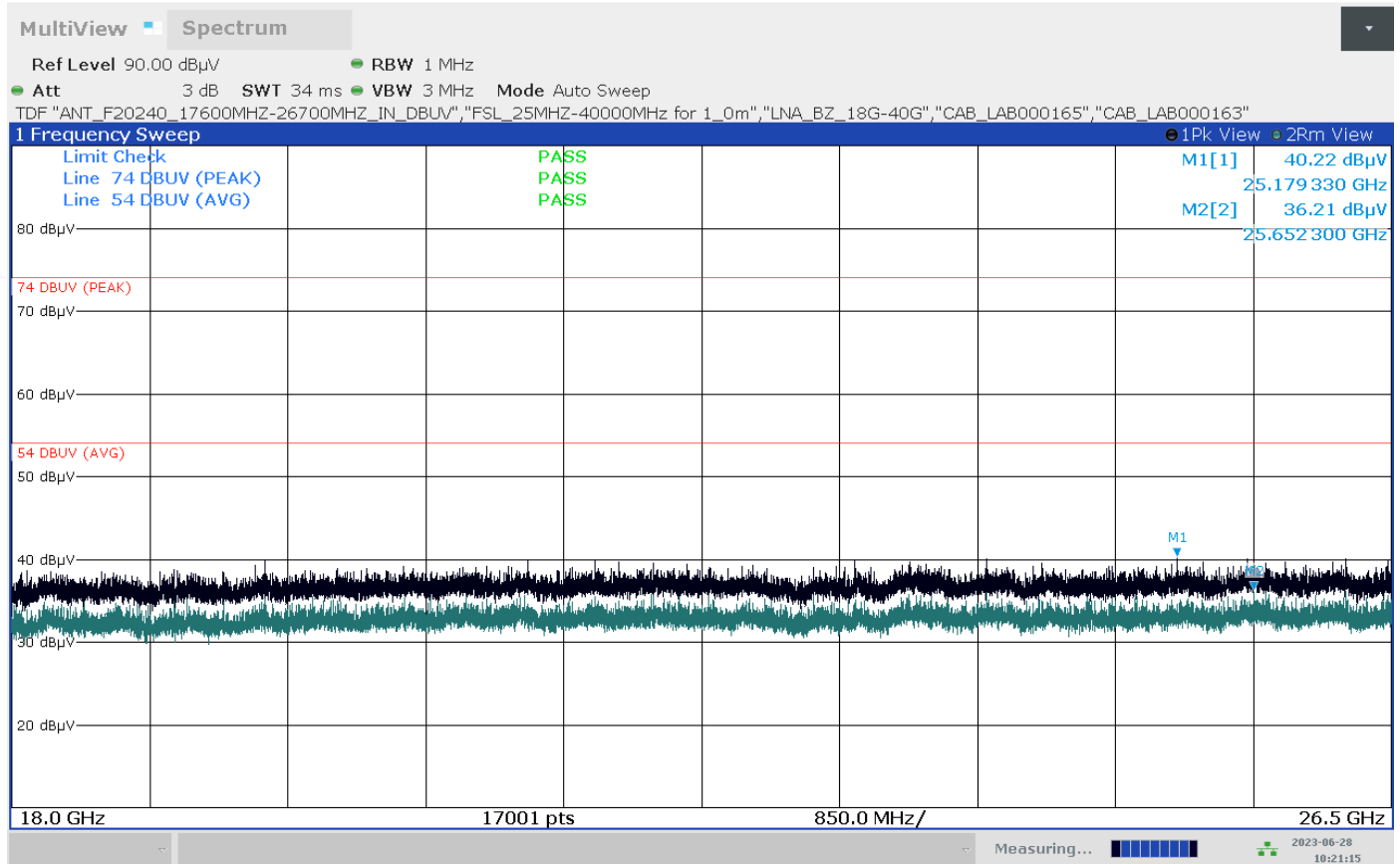

10:21:15 06/28/2023

Annex A of TR no.: 23038521-32373-2

39. Test: RSE 1 GHz - 3 GHz, EUT No: 80, SN: R0047, Mode 1, b-mode, channel 13, 2472 MHz

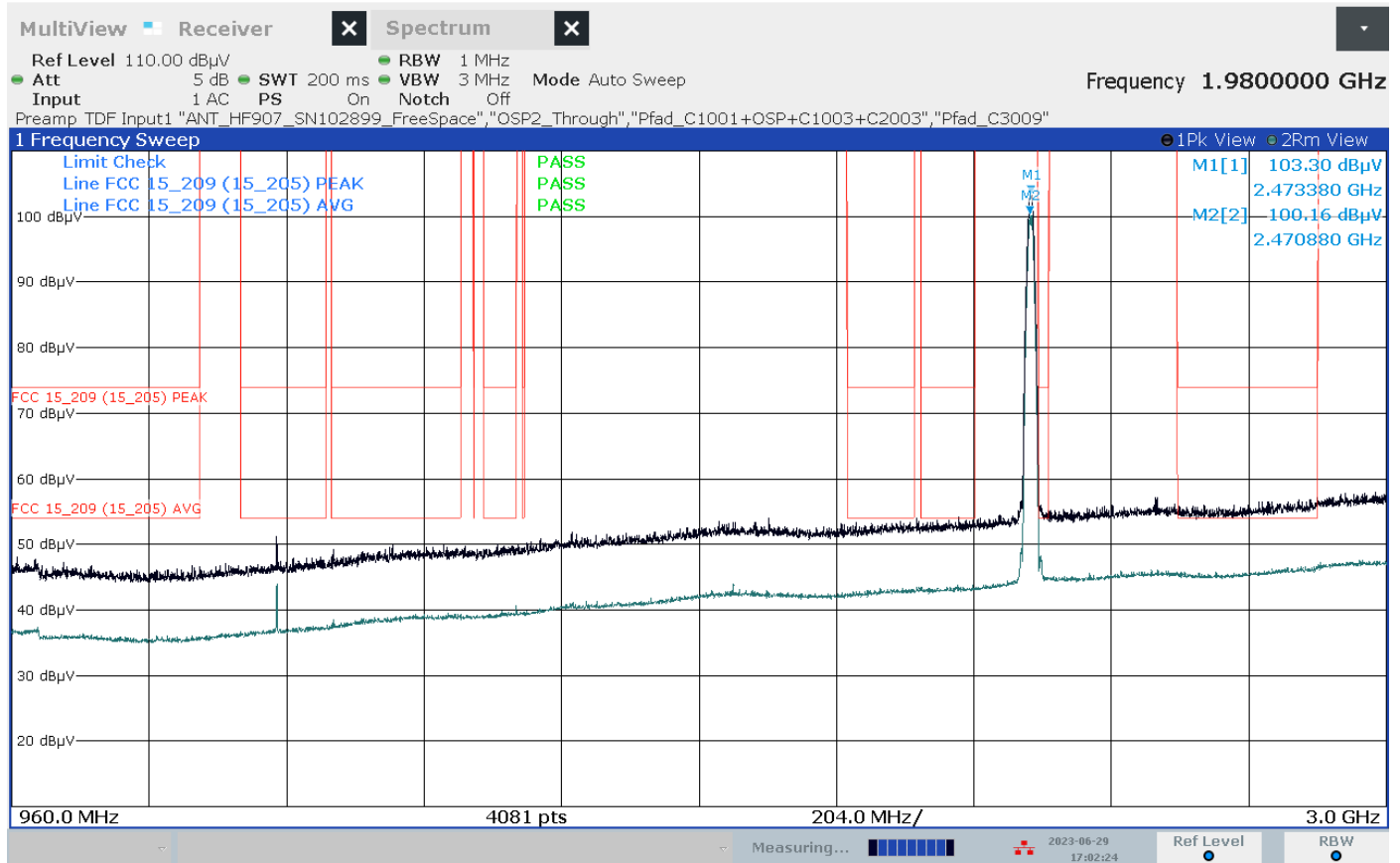

05:02:24 06/29/2023

Annex A of TR no.: 23038521-32373-2

40. Test: RSE 3 GHz - 9 GHz, EUT No: 80, SN: R0047, Mode 1, b-mode, channel 13, 2472 MHz

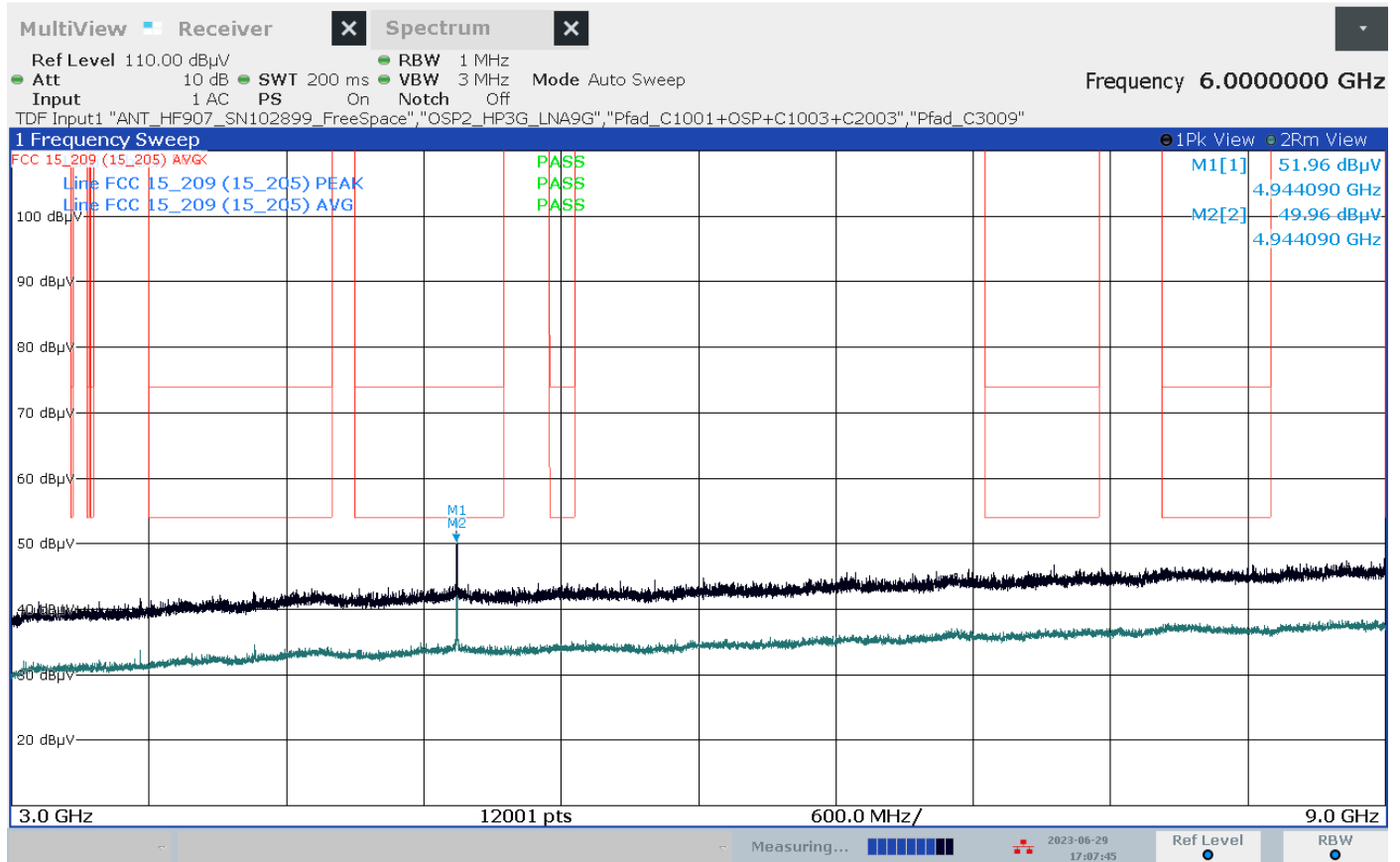

05:07:45 06/29/2023

Annex A of TR no.: 23038521-32373-2

41. Test: RSE 9 GHz - 18 GHz, EUT No: 80, SN: R0047, Mode 1, b-mode, channel 13, 2472 MHz

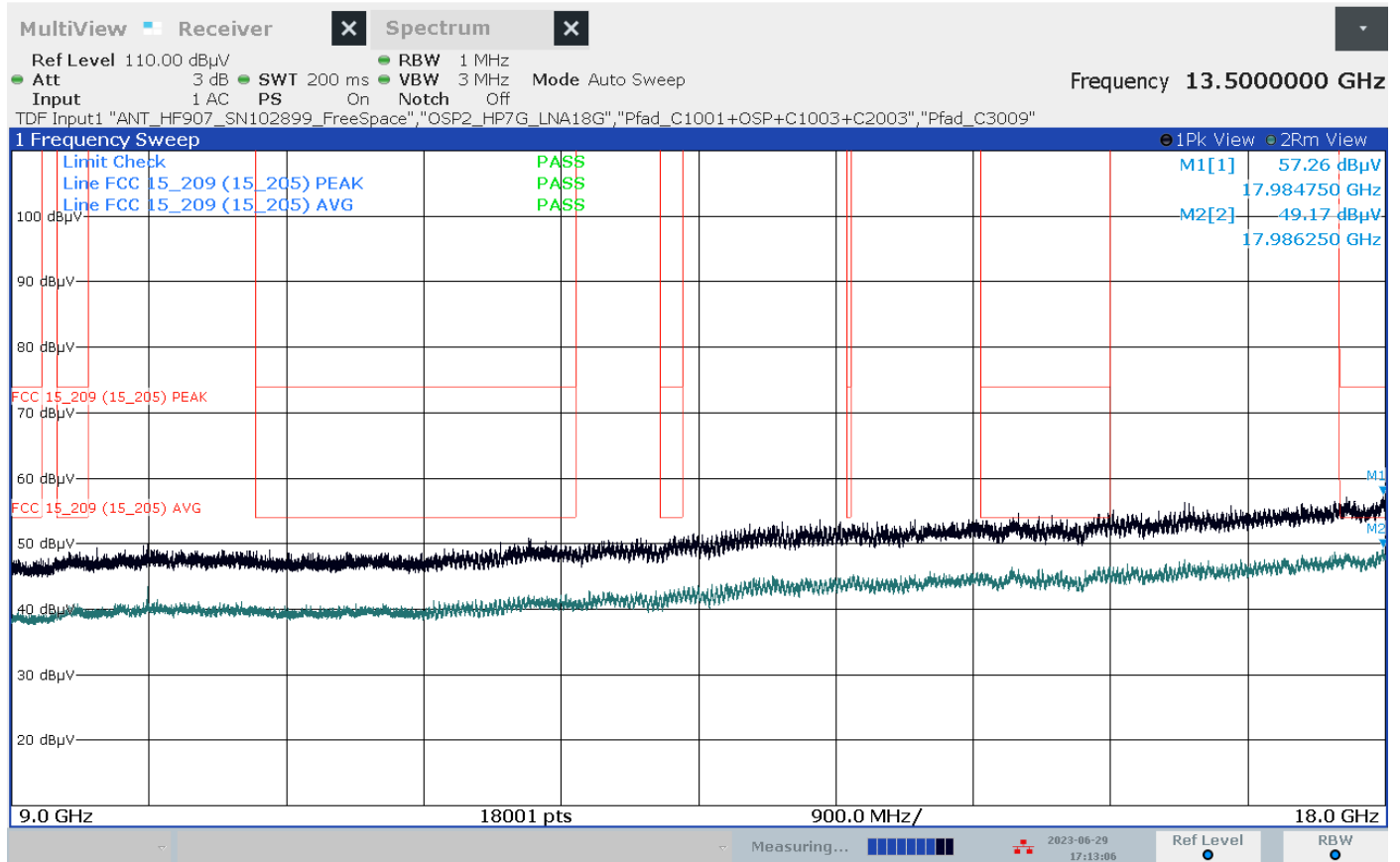

05:13:06 06/29/2023

Annex A of TR no.: 23038521-32373-2

42. Test: RSE 18 GHz - 26.5 GHz, EUT No: 80, SN: R0047, Mode 1, b-mode, channel 13, 2472 MHz

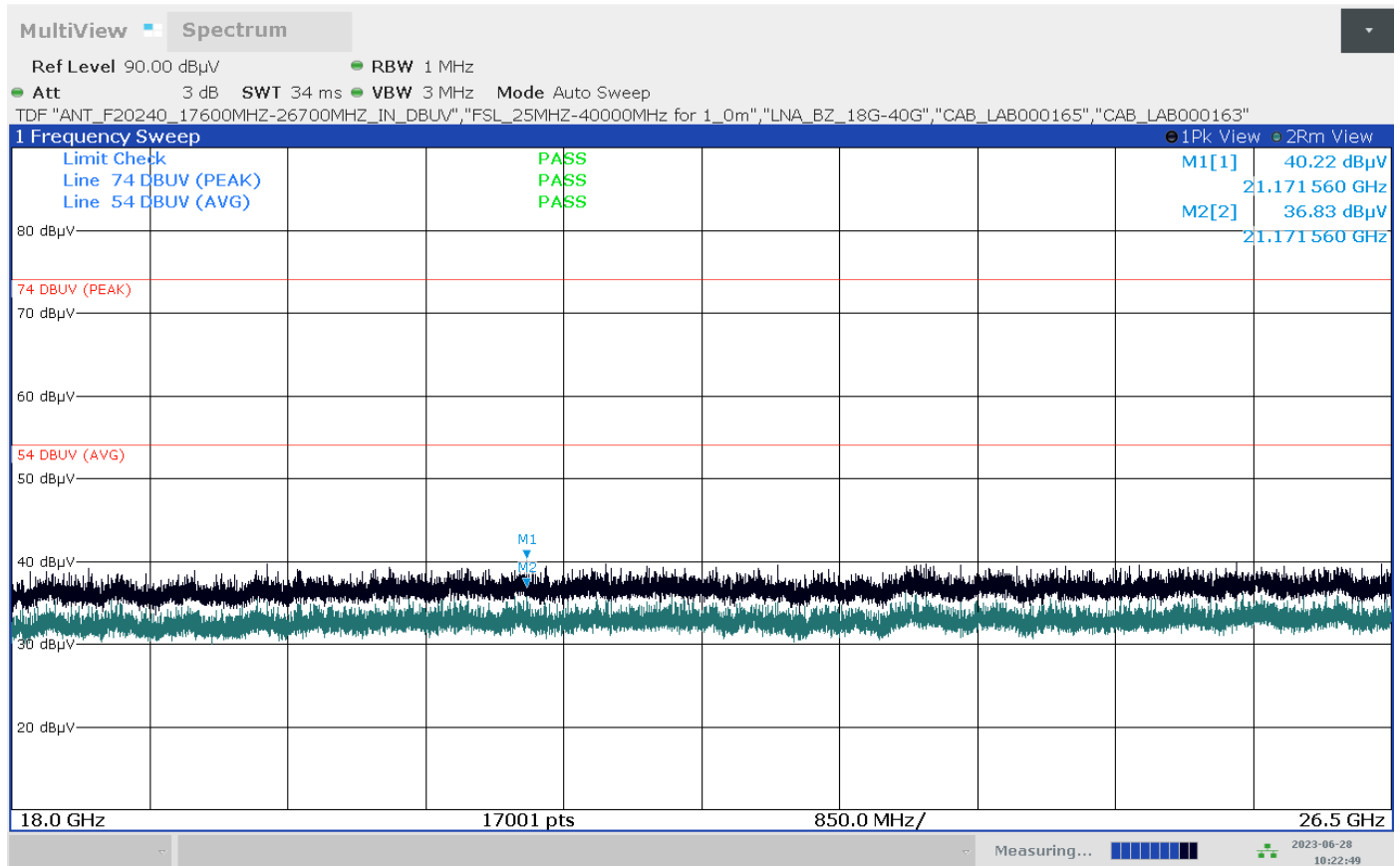

10:22:49 06/28/2023

Revision History

-0 Initial Version