

# FCC Part 15

# TEST REPORT

of

E.U.T.: Hookup

Trade Name: N/A

Model Number: LTK101

Prepared for

**LENNTEK CORPORATION**

4F 125, Guangming 3rd Road, Jhu Bei, Hsin Chu 30251,

Taiwan

TEL: +886 3 551 7771

FAX: +886 3 558 7227

Prepared by

**Interocean EMC Technology Corp.**

244 No.5-2, Lin 1, Tin-Fu Tsun, Lin-Kou Hsiang,

Taipei County, Taiwan, R.O.C.

TEL.: +886 2 2600 6861

FAX.: +886 2 2600 6859

**Remark:**

The test report consists of **70** pages in total. It shall not be reproduced except in full, without the written approval of IETC. This document may be altered or revised by IETC only, and shall be noted in the revision section of the document. The test results in the report only to the tested sample.

# TEST REPORT CERTIFICATION

**Applicant:** LENNTEK CORPORATION  
**Manufacturer:** LENNTEK CORPORATION  
**EUT Description:** Hookup  
**Model No.:** LTK101  
**Serial No.:** N/A  
**Tested Power Supply:** 120Vac, 60Hz  
**Date of Final Test:** Nov. 07, 2006

**Configuration of Measurements and Standards Used :**

FCC Rules and Regulations Part 15 Subpart B & C

I HEREBY CERTIFY THAT: The data shown in this report were made in accordance with the procedures given in ANSI C63.4, and the energy emitted by the device was founded to be within the limits applicable. I assume full responsibility for accuracy and completeness of these data.

- Note:** 1. The result of the testing report relate only to the item tested.  
2. The testing report shall not be reproduced expect in full, without the written approval of IETC

Report Issued: 2006/11/10

Test Engineer: Danny Tang  
Danny Tang  
2006  
1110

Checked: Jam Cheng  
Jam Cheng  
2006  
1110

Approved: Mike Huang  
Mike Huang  
2006  
1110

# Table of Contents

<b>1</b>	<b>General Information</b>	<b>6</b>
1.1	Description of Equipment Under Test	6
1.2	Table for Carrier Frequencies	7
1.3	Tested Supporting System Detail	8
1.4	Test Facility	9
1.5	Test Methodology	10
1.6	Bluetooth Approvals	10
1.7	Test Facility	10
<b>2</b>	<b>PROVISIONS APPLICABLE.</b>	<b>11</b>
2.1	Definition	11
2.2	Requirement for Compliance	12
2.3	Summary of Measurement	14
2.4	Restricted Bands of Operation	15
2.5	Labeling Requirement	16
2.6	User Information	16
<b>3</b>	<b>SYSTEM TEST CONFIGURATION</b>	<b>17</b>
3.1	Justification	17
<b>4</b>	<b>Power Line Conducted Emission Measurement</b>	<b>18</b>
<b>5</b>	<b>Radiated Emission Measurement</b>	<b>19</b>
5.1	Instrument	19
5.2	Instrument (For frequencies measured below 18 GHz)	19
5.3	Standard Applicable and limit	20
5.4	Block Diagram of Test Configuration	21
5.5	Measurement Instrument setting	22
5.6	Configuration of Measurement	22
5.7	Test Result	22
5.8	Field Strength Calculation	29
<b>6</b>	<b>ANTENNA REQUIREMENT</b>	<b>30</b>
6.1	Standard Applicable	30
6.2	Antenna Construction and Directional Gain	30

<b>7</b>	<b>HOPPING CHANNEL BANDWIDTH MEASUREMENT</b>	<b>31</b>
7.1	Instrument	31
7.2	Standard Applicable and limit	31
7.3	Block Diagram of Test Configuration	31
7.4	Measuring Instrument Setting	31
7.5	Configuration of Measurement	32
7.6	Measurement waveform	34
<b>8</b>	<b>MAXIMUM OUTPUT POWER MEASUREMENT</b>	<b>36</b>
8.1	Measurement Equipment	36
8.2	Standard Applicable and limit	36
8.3	Block Diagram of Test Configuration	36
8.4	Measurement Instrument setting	36
8.5	Configuration of Measurement	37
8.6	Measurement waveform	39
<b>9</b>	<b>100 kHz BANDWIDTH OF BAND EDGES MEASUREMENT</b>	<b>41</b>
9.1	Instrument	41
9.2	Standard Applicable	41
9.3	Block Diagram of Test Configuration	41
9.4	Measuring Instrument Setting	42
9.5	Configuration of Measurement	42
<b>10</b>	<b>HOPPING CHANNEL SEPARATION</b>	<b>45</b>
10.1	Instrument	45
10.2	Standard Applicable	45
10.3	Block Diagram of Test Configuration	45
10.4	Measuring Instrument Setting	45
10.5	Configuration of Measurement	46
10.6	Measurement waveform	48
<b>11</b>	<b>NUMBER OF HOPPING FREQUENCY USED</b>	<b>50</b>
11.1	Instrument	50
11.2	Standard Applicable and limit	50
11.3	Block Diagram of Test Configuration	50
11.4	Measuring Instrument Setting	50
11.5	Configuration of Measurement	51
11.6	Measurement waveform	53

<b>12</b>	<b>DWELL TIME ON EACH CHANNEL</b>	<b>54</b>
12.1	Instrument	54
12.2	Standard Applicable and limit	54
12.3	Block Diagram of Test Configuration	54
12.4	Measuring Instrument Setting	54
12.5	Configuration of Measurement	55
12.6	Measurement waveform	57
<b>13</b>	<b>HOPPING SEQUENCE TEST</b>	<b>63</b>
<b>14</b>	<b>Photographs of Test</b>	<b>64</b>
14.1	Radiated Emission Measurement	64
<b>15</b>	<b>Photographs of EUT</b>	<b>67</b>

## 1 General Information

### 1.1 Description of Equipment Under Test

**Equipment Under Test** : Hookup

**Model Number** : LTK101

**Serial Number** : N/A

**Type of Sample Tested** : Proto-type Pre-Production Mass Production

**Applicant** : **LENNTEK CORPORATION**  
4F 125, Guangming 3rd Road, Jhu Bei, Hsin Chu 30251, Taiwan

**Manufacturer** : **LENNTEK CORPORATION**  
4F 125, Guangming 3rd Road, Jhu Bei, Hsin Chu 30251, Taiwan

**Power Adapter** : **iPod USB Power Adapter:**  
Manufacturer: Apple computer  
Model NO.: A1102  
Input: 100~240Vac, 50 / 60Hz, 1.5A  
Output: 5Vdc, 1A  
Power Cable:  Shielded  Detachable, 1.5 m  w/o core

**Date of Receipt Sample** : September 11, 2006

**Date of Test** : September 18 ~ November 07, 2006

**Description of E.U.T.** : Bluetooth is a short-range radio link intended to be a cable replacement between portable and/or fixed electronic devices. Bluetooth operates in the unlicensed ISM Band at 2.4 GHz. In the US a band of 81MHz width is available. In this band, 79 RF channels spaced 1MHz apart a defined. The channel is represented by a pseudo-random hopping sequence through the 79 channels. The channel is divided into time slots, with a nominal slot length of 625µs, where each slot corresponds to different RF hop frequencies. The nominal hop rate is 1600 hops/s. All frequencies are equally used. The average time of occupancy is 0.3797 s within a 30 second period. The symbol rate on the channel is 1 Ms/s.

**Product information** : **Interface/ Port:**  
1. USB Port \*1  
2. Earphone Port \*1  
3. Power Port\*1

**Data Cable:**  
USB Cable\*1: Shielded Detachable, 1m w/o core

**Earphone:**  
Manufacturer: Hp invent

**iPod:**  
Manufacturer: Hp invent  
Model NO.: MP102

## 1.2 Table for Carrier Frequencies

Channel	Frequency	Channel	Frequency	Channel	Frequency
1	2402 MHz	31	2432 MHz	61	2462MHz
2	2403 MHz	32	2433 MHz	62	2463MHz
3	2404 MHz	33	2434MHz	63	2464MHz
4	2405 MHz	34	2435 MHz	64	2465MHz
5	2406 MHz	35	2436 MHz	65	2466MHz
6	2407 MHz	36	2437 MHz	66	2467MHz
7	2408 MHz	37	2438 MHz	67	2468MHz
8	2409 MHz	38	2439 MHz	68	2469 MHz
9	2410 MHz	39	2440 MHz	69	2470MHz
10	2411 MHz	40	2441 MHz	70	2471 MHz
11	2412 MHz	41	2442 MHz	71	2472 MHz
12	2413 MHz	42	2443 MHz	72	2473 MHz
13	2414 MHz	43	2444MHz	73	2474 MHz
14	2415 MHz	44	2445MHz	74	2475 MHz
15	2416 MHz	45	2446MHz	75	2476 MHz
16	2417 MHz	46	2447MHz	76	2477MHz
17	2418 MHz	47	2448MHz	77	2478 MHz
18	2419MHz	48	2449MHz	78	2479 MHz
19	2420 MHz	49	2450MHz	79	2480MHz
20	2421 MHz	50	2451MHz		
21	2422 MHz	51	2452MHz		
22	2423 MHz	52	2453MHz		
23	2424 MHz	53	2454MHz		
24	2425 MHz	54	2455MHz		
25	2426 MHz	55	2456MHz		
26	2427 MHz	56	2457MHz		
27	2428 MHz	57	2458MHz		
28	2429 MHz	58	2459MHz		
29	2430 MHz	59	2460MHz		
30	2431MHz	60	2461MHz		

### 1.3 Tested Supporting System Detail

#### 1.3.1 Personal Computer

PC20

Model Number : IBM ThinkCentre 8434-IVV  
Serial Number : 99MNC43  
CPU Speed : Pentium 4 Celeron D 2.2 Ghz  
EMC Approved : CE, FCC, C-Tick, UL, BSMI: R33026  
Manufacturer : IBM  
RAM : 256M\*1  
Hard Disk Driver : 40GB

#### 1.3.2 Data Cable

USB Cable : Shielded; 1Detachable, 1m w/o core

#### 1.3.3 Earphone

Model Number : Hp invent  
Serial Number : N/A

#### 1.3.4 iPod

Model Number : Hp invent  
Serial Number : MP102



#### 1.4 Test Facility

**Site Description** : OATS 1    OATS 2    OATS 3    OATS 4

**Name of Firm** : Interocean EMC Technology Corp.

**Site 1, 2 Location** : No.5-2, Lin 1, Tin-Fu Tsun, Lin-Kou Hsiang,  
Taipei County, Taiwan, R.O.C.

**Site 3, 4 Location** : No. 12, Ruei-Shu Valley, Ruei-Ping Tsuen, Lin-Kou Shiang,  
Taipei County, Taiwan, R.O.C.

**Site Filing** :

- Federal Communication Commissions – USA  
Registration No.: 96399 (Site 1 & 2)  
Registration No.: 518958 (Site 3 & 4)
- Voluntary Control Council for Interference by Information  
Technology Equipment (VCCI) – Japan  
Registration No. (Conducted Room): C-1094  
Registration No. (Conduction Area 3): C-1943  
Registration No. (Conduction Area 4): C-1944  
Registration No. (Conducted Room): T-271
- Registration No. (OATS 1): R-1040  
Registration No. (OATS 2): R-1041  
Registration No. (OATS 3): R-1812  
Registration No. (OATS 4): R-1813
- Industry Canada  
Submission: 113543

**Site Accreditation** :

- Bureau of Standards and Metrology and Inspection  
(BSMI) – Taiwan, R.O.C.  
Accreditation No.:  
SL2-IN-E-0026 for CNS13438 / CISPR22  
SL2-R1-E-0026 for CNS13439 / CISPR13  
SL2-R2-E-0026 for CNS13439 / CISPR13  
SL2-A1-E-0026 for CNS13783-1 / CISPR14-1
- National Voluntary Laboratory Accreditation Program  
(NVLAP) - USA  
Lab Code: 200458-0
- Nemko AS  
Authorization No.: ELA 181A  
Authorization No.: ELA 181B
- TÜV Rheinland  
Certificate No: 10006453-2006

## **1.5 Test Methodology**

For Hookup, both conducted and radiated emissions were performed according to the procedures illustrated in ANSI C63.4 (2003) and other required measurements were illustrated in separate sections of this test report for details.

## **1.6 Bluetooth Approvals**

For Hookup meeting the Bluetooth Specifications in the 2.4GHz band as of February 2001 operating in the USA.

## **1.7 Test Facility**

The open area test site and conducted measurement facility used to collect the radiated data is located on the roof top of Building at No.5-2, Lin 1, Tin-Fu Tsun, Lin-Kou Hsiang, Taipei County, Taiwan, R.O.C.

This site has been fully described in a report submitted to your office, and accepted in a letter dated Oct 28,2002.

## 2 PROVISIONS APPLICABLE.

### 2.1 Definition

**Unintentional radiator:**

A device that intentionally generates and radio frequency energy for use within the device, or that sends radio frequency signals by conduction to associated equipment via connecting wiring, but which is not intended to emit RF energy by radiation or induction.

**Class A Digital Device:**

A digital device which is marketed for use in commercial or business environment; exclusive of a device which is market for use by the general public, or which is intended to be used in the home.

**Class B Digital Device:**

A digital device which is marketed for use in a residential environment notwithstanding use in a commercial, business or industrial environment. Example of such devices that are marketed for the general public.

**Note:** A manufacturer may also qualify a device intended to be marketed in a commercial, business, or industrial environment as a Class B digital device, and in fact is encouraged to do so, provided the device complies with the technical specifications for a Class B Digital Device. In the event that a particular type of device has been found to repeatedly cause harmful interference to radio communications, the Commission may classify such a digital device as a Class B Digital Device, Regardless of its intended use.

**Intentional radiator:**

A device that intentionally generates and emits radio frequency energy by radiation or induction

## 2.2 Requirement for Compliance

### (1) Conducted Emission Requirement

For intentional device, according to §15.207(a) Line Conducted Emission Limits is same as below table.

For unintentional device, according to CISPR Line Conducted Emission Limits class B is as following:

Frequency (MHz)	Quasi Peak (dB $\mu$ V)	Average (dB $\mu$ V)
0.15 - 0.5	66-56	56-46
0.5 - 5.0	56	46
5.0 - 30.0	60	50

### (2) Radiated Emission Requirement

For unintentional device, according to §15.109(a), except for Class A digital devices, the field strength of radiated emissions from unintentional radiators at a distance of 3 meters shall not exceed the following values:

Frequency (MHz)	Distance Meters (m)	Radiated (dB $\mu$ V/m)	Radiated ( $\mu$ V/m)
30 - 88	3	40.0	100
88 - 216	3	43.5	150
216 - 960	3	46.0	200
Above 960	3	54.0	500

For intentional device, according to §15.209(a), the general requirement of field strength of radiated emissions from intentional radiators at a distance of 3 meters shall not exceed the above table.

For unintentional device, according to CISPR Line Radiated Emission Limits class B is as following:

Frequency (MHz)	Distance Meters (m)	Radiated (dB $\mu$ V/m)
30 to 230	10	30
230 to 1000	10	37

Frequency (MHz)	Average dB ( $\mu$ V/m)
Above 1000	54.0

### (3) Hopping Channel Separation and 20 dB Bandwidth

According to 15.247(a)(1), frequency hopping system shall have, hopping channel carrier frequencies separated by a minimum of 25 kHz or the 20 dB bandwidth of the hopping channel, whichever is greater.

Alternatively, frequency hopping systems operating in the 2400-2483.5 MHz band may have hopping channel carrier frequencies that are separated by 25 kHz or two-thirds of the 20 dB bandwidth of the hopping channel, whichever is greater.

**(4) Maximum Output Power Requirement**

According to 15.247(b)(1) For frequency hopping systems operating in the 2400-2483.5MHz band employing at least 75 hopping channels and all frequency hopping systems in the 5725MHz-5850MHz band: 1 Watt (30dBm). For all other frequency hopping systems in the 2400-2483.5 MHz band: 0.125 watts (20.97dBm). The limitation has to be reduced by the amount in dB that the gains of the antenna exceed 6dBi. In case of point-to-point operation, the limit has to be reduced by 1dB for every 3dB that the directional gain of the antenna exceeds 6dBi.

**(5) 100 kHz Bandwidth of Frequency Band Edges Requirement**

According to 15.247(c), in any 100 kHz bandwidth outside these frequency bands, the radio frequency power that is produced by the modulation products of the spreading sequence, the information sequence and the carrier frequency shall be either at least 20 dB below that in any 100 kHz bandwidth within the band that contains the highest level of the desired power or shall not exceed the general levels specified in § 15.209(a), whichever results in the lesser attenuation.

**(6) Number of Hopping Frequency used**

According to 15.247(a)(1)(iii), for frequency hopping system operating in the 2400-2483.5 MHz band shall use at least 15 non-overlapping channels. The average time of occupancy on any frequency shall not be greater than 0.4 second within a period of 0.4 seconds multiplied by the number of hopping channels employed

**(7) Dwell Time on each channel**

According to 15.247(a)(1)(iii), for frequency hopping system operating in the 2400-2483.5 MHz band shall use at least 15 non-overlapping channels. The average time of occupancy on any frequency shall not be greater than 0.4 second within a period of 0.4 seconds multiplied by the number of hopping channels employed

### 2.3 Summary of Measurement

Report Clause	Test Parameter	Remarks	Reference Document CFR47 Part15	Test result
4	Conducted Emission Requirement	Applicable	§15.207(a)	PASSED
5	Radiated Emission Requirement	Applicable	§15.209(a)	PASSED
7	20 dB Bandwidth	Applicable	§15.247(a) (1)	PASSED
8	Maximum Output Power Requirement	Applicable	§15.247(b) (1)	PASSED
9	100 kHz Bandwidth of Frequency Band Edges Requirement	Applicable	§15.247(d)	PASSED
10	Hopping Channel Separation	Applicable	§15.247(a) (1)	PASSED
11	Number of Hopping Frequency used	Applicable	§15.247(b) (1) (iii)	PASSED
12	Dwell Time on each channel	Applicable	§15.247(a)(1)(iii)	PASSED
6	Antenna Requirement	N/A	§15.203	Compliance

## 2.4 Restricted Bands of Operation

Only spurious emissions are permitted in any of the frequency bands listed below:

MHz	MHz	MHz	GHz
0.090 - 0.110	16.42-16.423	399.9-410	4.5-5.25
0.495 - 0.505 **	16.69475 - 16.69525	608-614	5.35-5.46
2.1735 - 2.1905	16.80425 - 16.80475	960-1240	7.25-7.75
4.125-4.128	25.5-25.67	1300-1427	8.025-8.5
4.17725-4.17775	37.5-38.25	1435-1626.5	9.0-9.2
4.20725-4.20775	73-74.6	1645.5-1646.5	9.3-9.5
6.215-6.218	74.8-75.2	1660-1710	10.6-12.7
6.26775-6.26825	108-121.94	1718.8-1722.2	13.25-13.4
6.31175-6.31225	123-138	2200-2300	14.47-14.5
8.291-8.294	149.9-150.05	2310-2390	15.35-16.2
8.362-8.366	156.52475 - 156.52525	2483.5-2500	17.7-21.4
8.37625-8.38675	156.7-156.9	2655-2900	22.01-23.12
8.41425-8.41475	162.0125-167.17	3260-3267	23.6-24.0
12.29-12.293	167.72-173.2	3332-3339	31.2-31.8
12.51975-12.52025	240-285	3345.8-3358	36.43-36.5
12.57675-12.57725	322-335.4	3360-4400	Above 38.6
13.36-13.41			

\*\* : Until February 1, 1999, this restricted band shall be 0.490-0.510 MHz

## 2.5 Labeling Requirement

The device shall bear the following statement in a conspicuous location on the device:

This device complies with part 15 of the FCC Rules. Operation is subject to the following two conditions: (1) This device may not cause harmful interference, and (2) this device must accept any interference received, including interference that may cause undesired operation.

## 2.6 User Information

The users manual or instruction manual for an intentional or unintentional radiator shall caution the user that changes or modifications not expressly approved by the party responsible for compliance could void the user's authority to operate the equipment.

For a Class B digital device or peripheral, the instructions furnished the user shall include the following or similar statement, placed in a prominent location in the text of the manual.

The Federal Communications Commission Radio Frequency Interference Statement includes the following paragraph.

This equipment has been tested and found to comply with the limits for a Class B Digital Device, pursuant to Part 15 of the FCC Rules. These limits are designed to provide reasonable protection against harmful interference in a residential installation.

This equipment generates, uses and can radiate radio frequency energy and, if not installed and used in accordance with the instruction may cause harmful interference to radio communication. However, there is no guarantee that interference will not occur in a particular installation.

If this equipment does cause harmful interference to radio or television reception, which can be determined by turning the equipment off and on, the user is encouraged to try to correct the interference by one or more of the following measures:

- Reorient or relocate the receiving antenna.
- Increase the separation between the equipment and receiver.
- Connect the equipment into an outlet on a circuit different from that to which the receiver is connected.
- Consult the dealer or an experienced radio / TV technician for help.



### **3 SYSTEM TEST CONFIGURATION**

#### **3.1 Justification**

For both radiated and conducted emissions below 1 GHz, the system was configured for testing in a typical fashion, as a customer would normally use it. The peripherals other than EUT were connected in normally standing by situation. Measurement was performed under the condition that a computer program was exercised to simulate data communication of EUT, and the transmission rate was set to maximum allowed by EUT. Three highest emissions were verified with varying placement of the transmitting antenna connected to EUT to maximize the emission from EUT.

For conducted emissions, only measured on TX / RX and charge mode operation, for the digital circuits portion also function normally whenever TX or RX is operated. For radiated emissions, whichever RF channel is operated, the digital circuits function identically. As the reason, measurement of radiated emissions from digital circuits is only performed by transmitting mode. During the preliminary test, the worse cases are TX / RX and charge mode, and data presented in this test report just shows the worse case.

## **4 Power Line Conducted Emission Measurement**

**The EUT is power by battery; therefore it does not need to perform this test.**

## 5 Radiated Emission Measurement

### 5.1 Instrument

Instrument	Manufacturer	Model	Serial No.	Last Calibration
EMI Test Receiver	Rohde & Schwarz	ESI7	830154/002	2006/08/09
Spectrum Analyzer	Agilent	8564EC	4046A00331	2006/03/27
Spectrum Analyzer	R&S	FSP30	100002	2005/11/07
Test Receiver	R&S	ESVS10	826148/011	2006/06/15
Bilog Antenna	Schaffner	CBL6112B	2811	2005/11/07
Preamplifier	Agilent	8449B	3008A01434	2006/04/10
Preamplifier	Agilent	8447D	2944A09703	2006/04/20
Loop Antenna	Schaffner	HLA6120	1171	2006/08/01

Note: All instrument upon which need to be calibrated are within calibration period of 1 year.

Instrument	Manufacturer	Model	Serial No.	Last Calibration
Horn Antenna	COM-POWER	AH-118	10081	2006/05/16
Horn Antenna	Schwarzbeck	BBHA 9170	BBHA9170213	2006/06/13

Note: All instrument upon which need to be calibrated are within calibration period of 2 year.

### 5.2 Instrument (For frequencies measured below 18 GHz)

Instrument	Manufacturer	Model	Serial No.	Last Calibration
Spectrum Analyzer	Agilent	8564EC	4046a00331	2006/03/27
Cable	IETC	CBL07	CBL07	2006/05/09

Note: All instrument upon which need to be calibrated are within calibration period of 1 year.

Instrument	Manufacturer	Model	Serial No.	Last Calibration
Horn Antenna	Schwarzbeck	BBHA 9170	BBHA9170213	2006/06/13
Preamplifier	Agilent	83050A	3950A00225	2006/08/03

Note: All instrument upon which need to be calibrated are within calibration period of 2 year.

### 5.3 Standard Applicable and limit

For intentional radiator, the radiated emission shall comply with §15.209(a).

For intentional radiators, according to §15.247 (a), operation under this provision is limited to frequency hopping and direct sequence spread spectrum, and the out band emission shall be comply with §15.247 (c)

Frequency (MHz)	<input type="checkbox"/> Class A	<input checked="" type="checkbox"/> Class B
	Quasi-Peak dB(uV/m)	Quasi-Peak dB(uV/m)
30 ~ 230	40.0	30.0
230 ~ 1000	47.0	37.0

Frequency (MHz)	Average dB(uV/m)
Above 1000	54.0

### 5.4 Block Diagram of Test Configuration

Frequencies measured below 1 GHz configuration

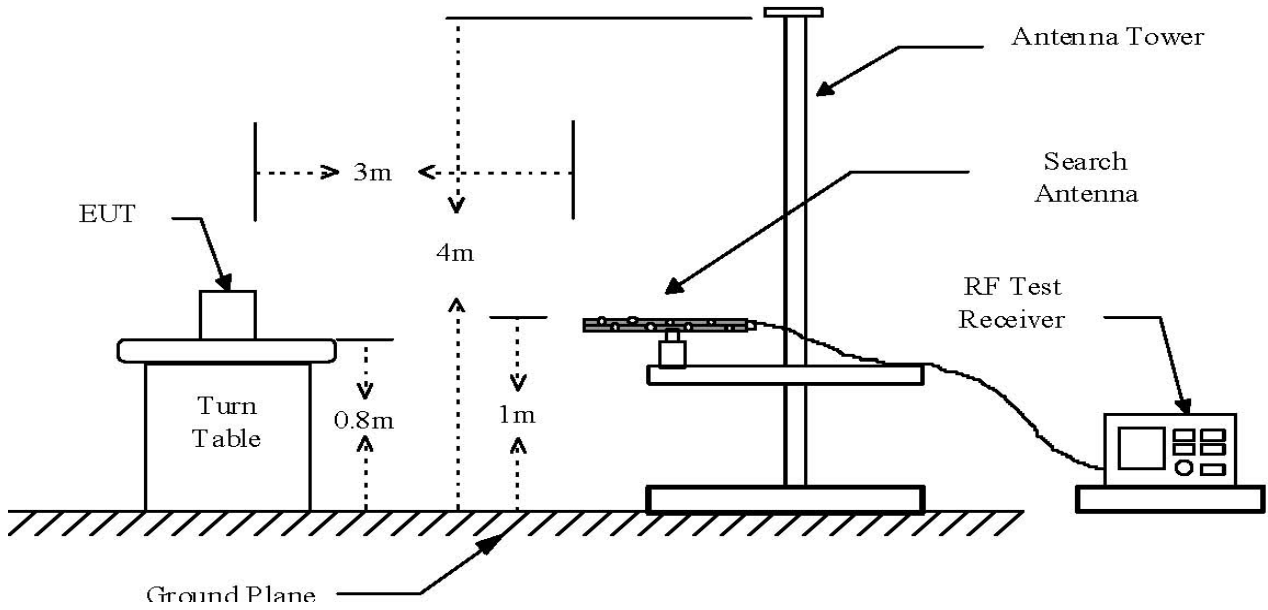

Frequencies measured from 1GHz to 18 GHz configuration

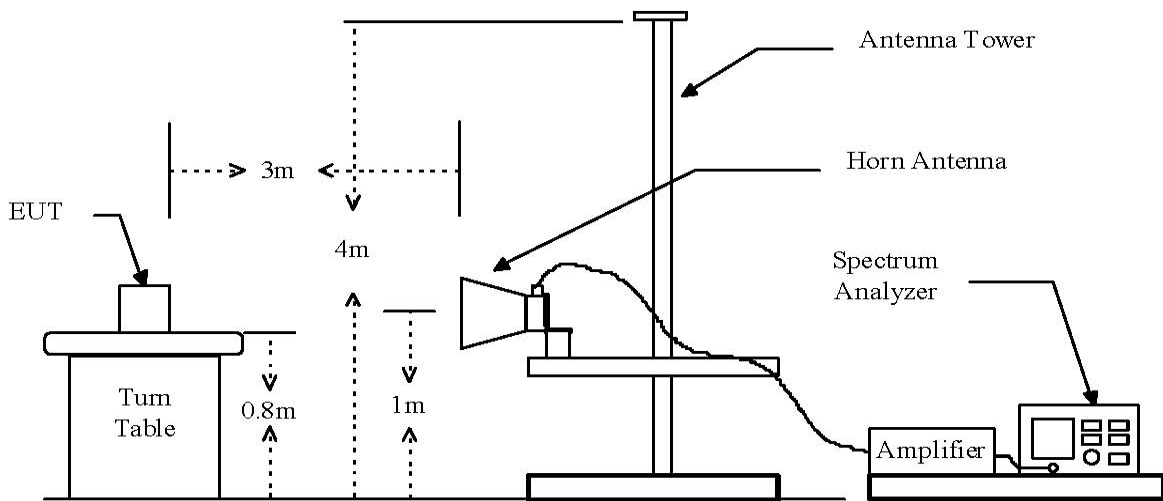

Frequencies measured above 18 GHz configuration

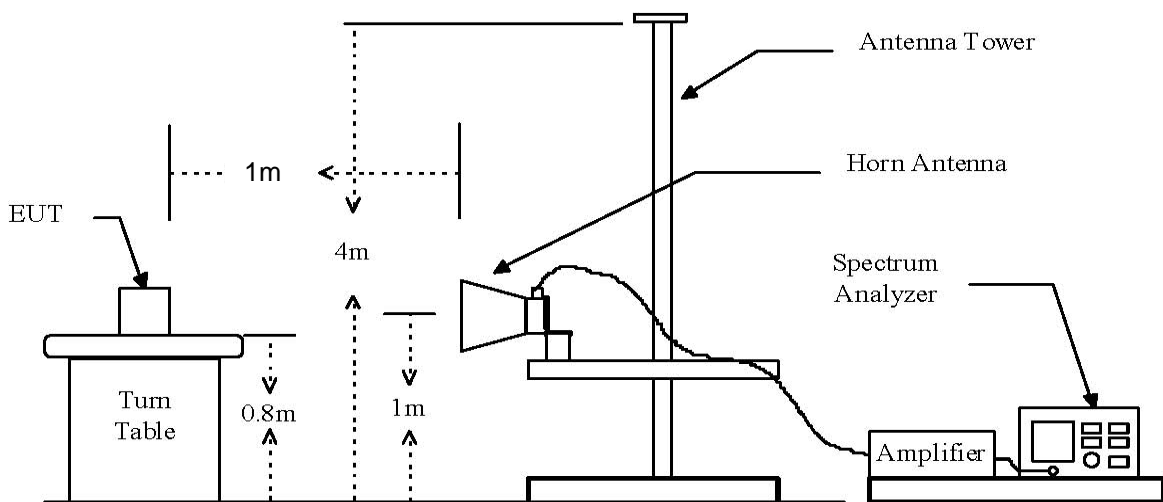

## 5.5 Measurement Instrument setting

- 5.5.1 Set the EMI test receiver frequency range from 30 MHz to 1000 MHz.
- 5.5.2 Set the EMI test receiver bandwidth at 120 kHz.
- 5.5.3 Set the EMI test receiver detector as Quasi-Peak (Q.P.).

## 5.6 Configuration of Measurement

- 5.6.1 Setup the configuration per 5.2 for frequencies measured below and above 1 GHz respectively.
- 5.6.2 For emission frequencies measured below 1 GHz, a pre-scan is performed in a shielded chamber to determine the accurate frequencies of higher emissions will be checked on a open test site. As the same purpose, for emission frequencies measured above 1 GHz, a pre-scan also be performed with a 1 meter measuring distance before final test.
- 5.6.3 For emission frequencies measured below and above 1 GHz, set the spectrum analyzer on a 100 kHz and 1 MHz resolution bandwidth respectively for each frequency measured in step 5.5.2.
- 5.6.4 The search antenna is to be raised and lowered over a range from 1 to 4 meters in horizontally polarized orientation. Position the highness when the highest value is indicated on spectrum analyzer, then change the orientation of EUT on test table over a range from 0 ° to 360 ° with a speed as slow as possible, and keep the azimuth that highest emission is indicated on the spectrum analyzer. Vary the antenna position again and record the highest value as a final reading. A RF test receiver is also used to confirm emissions measured.
- 5.6.5 Note: A band pass filter was used to avoid pre-amplifier saturated when measure TX operation mode in frequency band above 1 GHz.
- 5.6.6 Repeat step 5.5.4 until all frequencies need to be measured were complete.
- 5.6.7 Repeat step 5.5.5 with search antenna in vertical polarized orientations.
- 5.6.8 Check the three frequencies of highest emission with varying the placement of cables associated with EUT to obtain the worse case and record the result.

## 5.7 Test Result

**PASS.**

Results for the radiated measurements below 30MHz according §15.33

Frequency	Measured Values	Remarks
10KHz-30MHz	No emission found, caused by the EUT	This is valid for all the test channels

The final tested data are shown on following pages.

## Radiated Emission Measurement Data

EUT: Hookup CLIENT: LENNTEK CORPORATION MODEL: LTK101 RATING: From iPOD Temperature: 23.8 °C Humidity: 71 %	POLARITY: Horizontal DISTANCE: 3 m Serial No.: FILE/DATA#: LENNTEK CORPORATION.emi/13 OPERATOR: SUNNY TEST SITE: OATS1
--	---

Frequency	Factor	Meter Reading	Emission Level	Limits	Margin
(MHz)	(dB)	(dBuV)	(dBuV/m)	(dBuV/m)	(dB)
48.186 **	-20.69	40.26	19.57	40.00	-20.43
114.478 **	-18.51	41.02	22.51	43.52	-21.01
120.018 **	-18.46	40.26	21.80	43.52	-21.72
164.074 **	-19.42	41.83	22.41	43.52	-21.11
180.018 **	-20.80	42.98	22.18	43.52	-21.34
240.006 **	-17.84	42.98	25.14	46.02	-20.88
372.270 **	-13.08	34.40	21.32	46.02	-24.70
419.993 **	-11.70	34.61	22.91	46.02	-23.11
439.090 **	-11.21	36.96	25.75	46.02	-20.27
463.175 **	-10.55	38.51	27.96	46.02	-18.06

**Remark:**

1. " \* " Mark means readings are Peak Values.
2. " \*\* " Mark means readings are Quasi-Peak values.
3. Factor = Antenna Factor + Cable Loss – Pre-amplifier.

LIMIT: FCCB\_30M-1G(3m). LMT

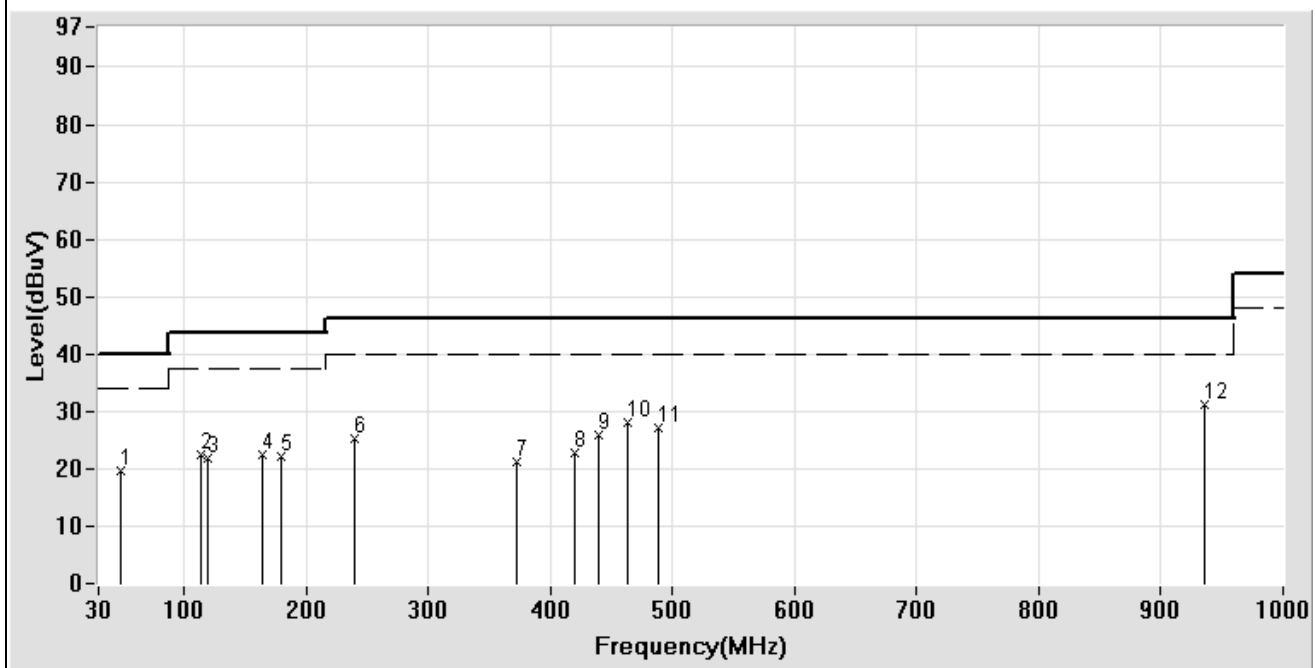

Test Mode: Mode 1: TX & RX Mode

## Radiated Emission Measurement Data

EUT: Hookup CLIENT: LENNTEK CORPORATION MODEL: LTK101 RATING: From iPod Temperature: 28.1 °C Humidity: 63 %	POLARITY: Horizontal DISTANCE: 3 m Serial No.: FILE/DATA#: LENNTEK CORPORATION.emi/4 OPERATOR: SUNNY TEST SITE: OATS1
--	--

Frequency	Factor	Meter Reading	Emission Level	Limits	Margin
(MHz)	(dB)	(dBuV)	(dBuV/m)	(dBuV/m)	(dB)
2410.821 **	-3.25	36.52	39.77	54.00	-14.23
4912.820 **	-10.84	24.00	34.84	54.00	-19.16

**Remark:**

1. " \* " Mark means readings are Peak Values.
2. " \*\* " Mark means readings are Quasi-Peak values.
3. Factor = Antenna Factor + Cable Loss – Pre-amplifier.

LIMIT: FCCBH\_ABOVE 1G(3m). LMT

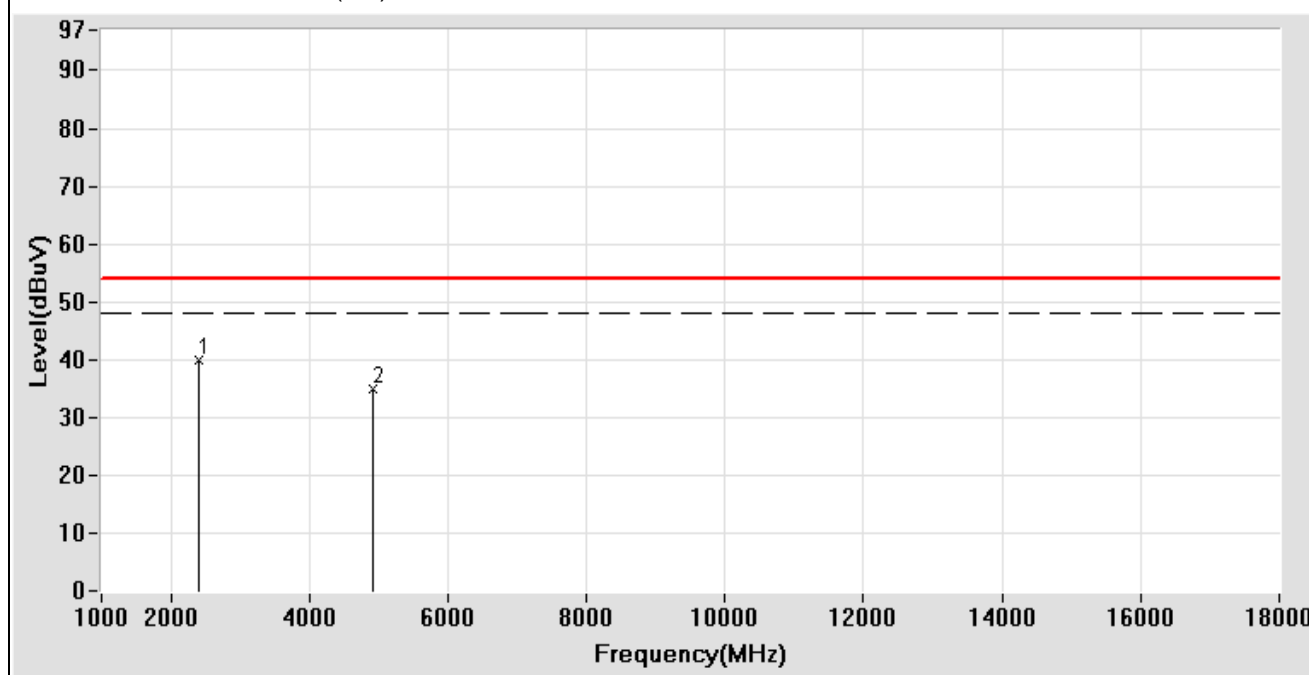

Test Mode: Mode 1: TX & RX Mode



## Radiated Emission Measurement Data

EUT: Hookup CLIENT: LENNTEK CORPORATION MODEL: LTK101 RATING: From iPod Temperature: 28.1 °C Humidity: 63 %	POLARITY: Horizontal DISTANCE: 1m Serial No.: FILE/DATA#: LENNTEK CORPORATION.emi/4 OPERATOR: SUNNY TEST SITE: OATS1
--	---

Frequency	Factor	Meter Reading	Emission Level	Limits	Margin
(GHz)	(dB)	(dBuV)	(dBuV/m)	(dBuV/m)	(dB)
19.84*	-12.6	40.86	53.46	63.5	-10.04
22.3*	-13	40.5	53.5	63.5	-10
24.8*	-13.7	44.61	58.31	63.5	-5.19

Remark:

1. " \* " Mark means readings are Peak Values.
2. " \*\* " Mark means readings are Quasi-Peak values.
3. Factor = Antenna Factor + Cable Loss – Pre-amplifier.

LIMIT: FCCBH\_ABOVE 1G(3M). LMT

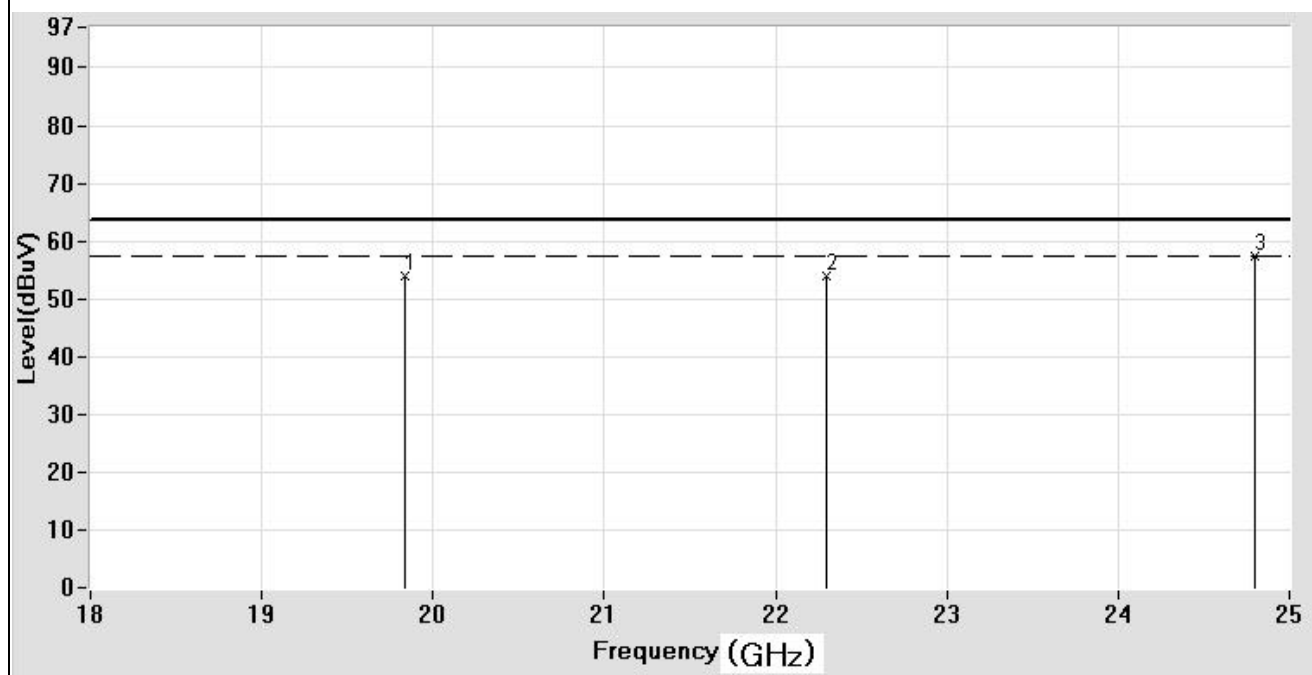

Test Mode: Mode 1: TX & RX Mode

## Radiated Emission Measurement Data

EUT: Hookup CLIENT: LENNTEK CORPORATION MODEL: LTK101 RATING: From iPod Temperature: 23.8 °C Humidity: 71 %	POLARITY: Vertical DISTANCE: 3 m Serial No.: FILE/DATA#: LENNTEK CORPORATION.emi/12 OPERATOR: SUNNY TEST SITE: OATS1
--	---

Frequency (MHz)	Factor (dB)	Meter Reading (dBuV)	Emission Level (dBuV/m)	Limits (dBuV/m)	Margin (dB)
68.736 **	-23.51	44.65	21.14	30.00	-8.86
113.715 **	-17.69	41.65	23.96	30.00	-6.04
120.042 **	-18.21	40.32	22.11	30.00	-7.89
134.180 **	-17.12	36.89	19.77	30.00	-10.23
171.791 **	-19.55	40.20	20.65	30.00	-9.35
180.090 **	-20.30	40.74	20.44	30.00	-9.56
240.190 **	-17.67	40.69	23.02	37.00	-13.98
439.244 **	-11.05	37.74	26.69	37.00	-10.31
463.172 **	-10.27	37.57	27.30	37.00	-9.70
489.970 **	-9.72	34.42	24.70	37.00	-12.30

**Remark:**

1. " \*" Mark means readings are Peak Values.
2. " \*\* " Mark means readings are Quasi-Peak values.
3. Factor = Antenna Factor + Cable Loss – Pre-amplifier.

LIMIT: CISPR22B (3m). LMT

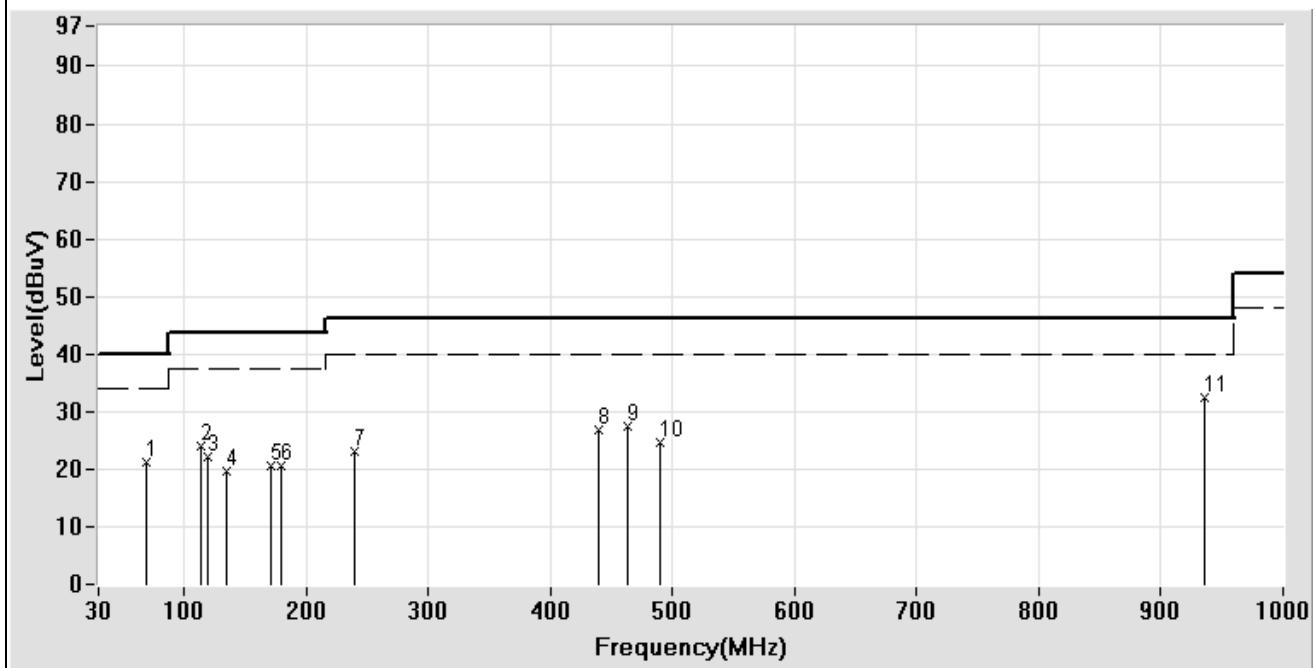

Test Mode: Mode 1: TX & RX Mode

## Radiated Emission Measurement Data

EUT: Hookup CLIENT: LENNTEK CORPORATION MODEL: LTK101 RATING: From iPod Temperature: 28.1 °C Humidity: 63 %	POLARITY: Vertical DISTANCE: 3 m Serial No.: FILE/DATA#: LENNTEK CORPORATION.emi/5 OPERATOR: SUNNY TEST SITE: OATS1
--	--

Frequency	Factor	Meter Reading	Emission Level	Limits	Margin
(MHz)	(dB)	(dBuV)	(dBuV/m)	(dBuV/m)	(dB)
2414.829 **	-3.28	36.82	40.10	54.00	-13.90
4911.823 **	-10.83	23.54	34.37	54.00	-19.63

**Remark:**

1. " \* " Mark means readings are Peak Values.
2. " \*\* " Mark means readings are Quasi-Peak values.
3. Factor = Antenna Factor + Cable Loss – Pre-amplifier.

LIMIT: FCCBH\_ABOVE 1G(3m). LMT

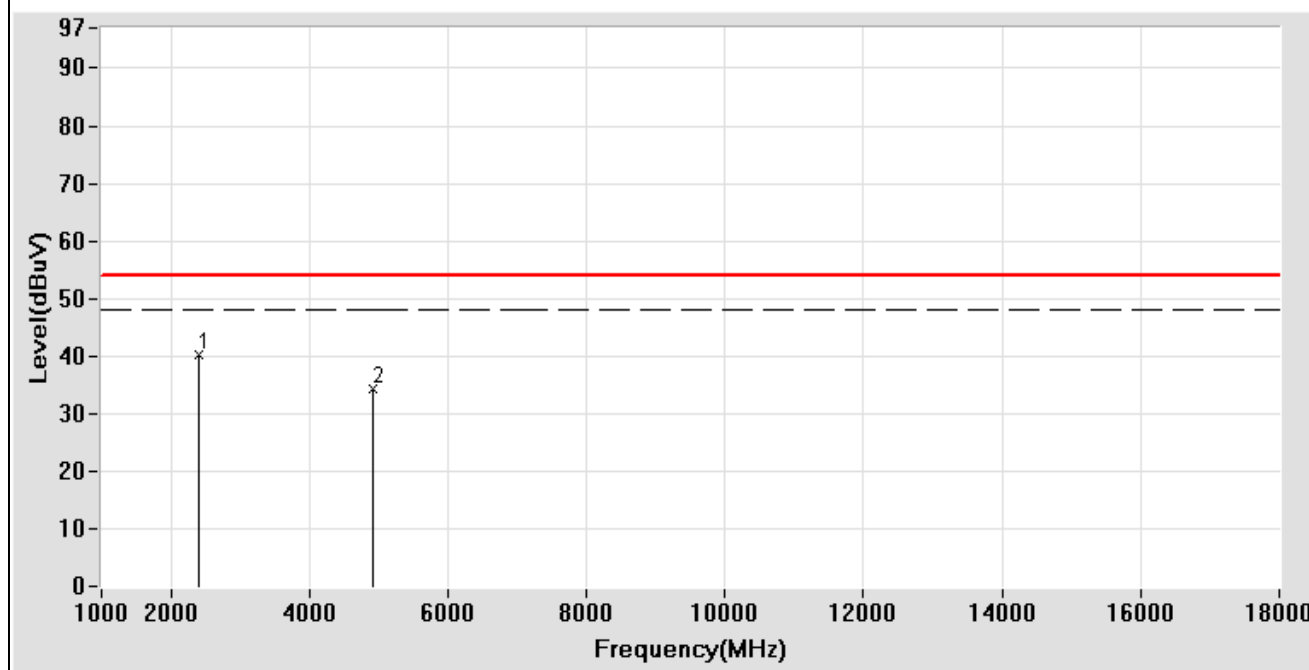

Test Mode: Mode 1: TX & RX Mode

## Radiated Emission Measurement Data

EUT: Hookup CLIENT: LENNTEK CORPORATION MODEL: LTK101 RATING: From iPod Temperature: 28.1 °C Humidity: 63 %	POLARITY: Vertical DISTANCE: 1m Serial No.: FILE/DATA#: LENNTEK CORPORATION.emi/4 OPERATOR: SUNNY TEST SITE: OATS1
--	---

Frequency	Factor	Meter Reading	Emission Level	Limits	Margin
(GHz)	(dB)	(dBuV)	(dBuV/m)	(dBuV/m)	(dB)
19.84*	-12.6	40.86	53.46	63.5	-10.04
22.3*	-13	40.5	53.5	63.5	-10
24.8*	-13.7	44.61	58.31	63.5	-5.19

Remark:

1. " \* " Mark means readings are Peak Values.
2. " \*\* " Mark means readings are Quasi-Peak values.
3. Factor = Antenna Factor + Cable Loss – Pre-amplifier.

LIMIT: FCCBH\_ABOVE 1G(1m). LMT

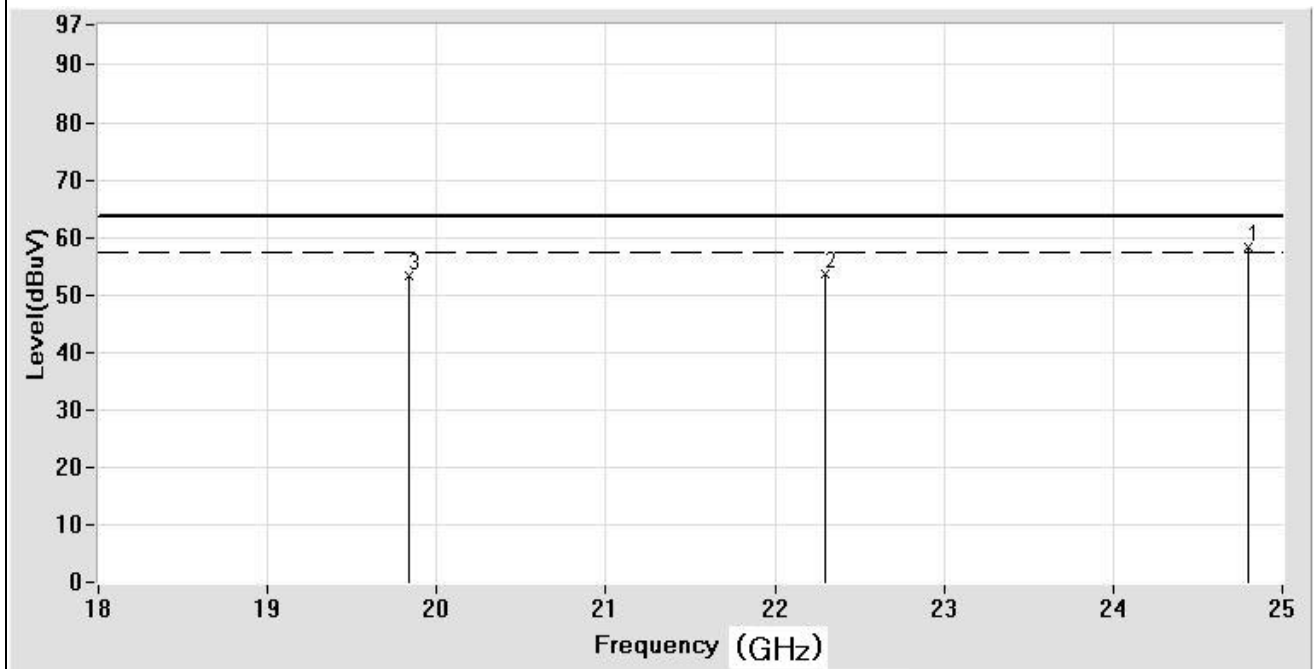

Test Mode: Mode 1: TX & RX Mode

## 5.8 Field Strength Calculation

The field strength is calculated by adding the Antenna Factor, High Pass Filter Loss(if used) and Cable Loss, and subtracting the Amplifier Gain (if any) from the measured reading. The basic equation calculation is as follows:

$$\text{Result} = \text{Reading} + \text{Corrected Factor}$$

where Corrected Factor = Antenna FACTOR + Cable Loss + High Pass Filter Loss - Amplifier Gain

## **6 ANTENNA REQUIREMENT**

### **6.1 Standard Applicable**

For intentional device, according to §15.203, an intentional radiator shall be designed to ensure that no antenna other than that furnished by the responsible party shall be used with the device. And according to §15.247 (b), if transmitting antennas of directional gain greater than 6 dBi are used, the power shall be reduced by the amount in dB that the directional gain of the antenna exceeds 6 dBi.

### **6.2 Antenna Construction and Directional Gain**

This device uses PCB antenna. Please see photo of EUT (**Page 65**).

The max antenna gain is **0.56 dBi** for Headset.

## 7 HOPPING CHANNEL BANDWIDTH MEASUREMENT

### 7.1 Instrument

Instrument	Manufacturer	Model	Serial No.	Last Calibration
Spectrum Analyzer	Rohde & Schwarz	FSP30	100002	2005/11/07

Note: All instrument upon which need to be calibrated are within calibration period of 1 year.

### 7.2 Standard Applicable and limit

According to §15.247(a)(1), Frequency hopping systems shall have hopping channel carrier frequencies separated by a minimum of 25 kHz or the 20 dB bandwidth of the hopping channel, whichever is greater.

Alternatively, frequency hopping systems operating in the 2400-2483.5 MHz band may have hopping channel carrier frequencies that are separated by 25 kHz or two-thirds of the 20 dB bandwidth of the hopping channel, whichever is greater.

### 7.3 Block Diagram of Test Configuration

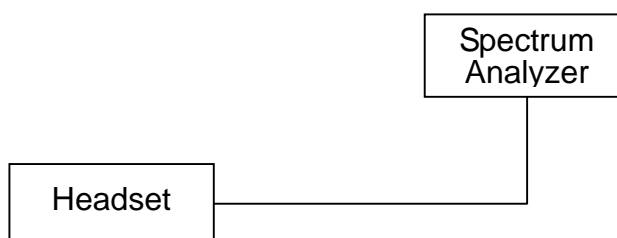

### 7.4 Measuring Instrument Setting

Spectrum Parameter	Setting
Attenuation	20dB
Span Frequency	> Measurement Bandwidth or Channel Separation
RB	100 kHz (20dB Bandwidth) / 1MHz (Channel Separation)
VB	1MHz (20dB Bandwidth) / 1MHz (Channel Separation)
Detector	Peak
Trace	Max Hold
Sweep Time	125ms

## 7.5 Configuration of Measurement

- 7.5.1 Check the calibration of the measuring instrument using either an internal calibrator or a known signal from an external generator.
- 7.5.2 Position the EUT as shown in section 7.3 without connection to measurement instrument. Turn on the EUT and connect it to measurement instrument. Then set it to any one convenient frequency within its operating range. Set a reference level on the measuring instrument equal to the highest peak value.
- 7.5.3 Measure the frequency difference of two frequencies that were attenuated 20dB from the reference level. Record the frequency difference as the emission bandwidth.
- 7.5.4 Repeat above procedures until all frequencies measured were complete.

Test result

**PASS.**

The final test data and waveform are shown on as following pages



## HOPPING CHANNEL BANDWIDTH MEASUREMENT DATA

Ambient temperature : 26°C  
Relative humidity : 59%  
Test Mode : Headset

Channel	Frequency (MHz)	20dB Emission Bandwidth (KHz)	Max. Limit (dB)
CH1	2402	372	> 20dB or 2/3 of 20dB
CH40	2441	356	> 20dB or 2/3 of 20dB
CH79	2480	360	> 20dB or 2/3 of 20dB

Note: 1. The expanded uncertainty of the emission bandwidth tests is 1500Hz

### 7.6 Measurement waveform

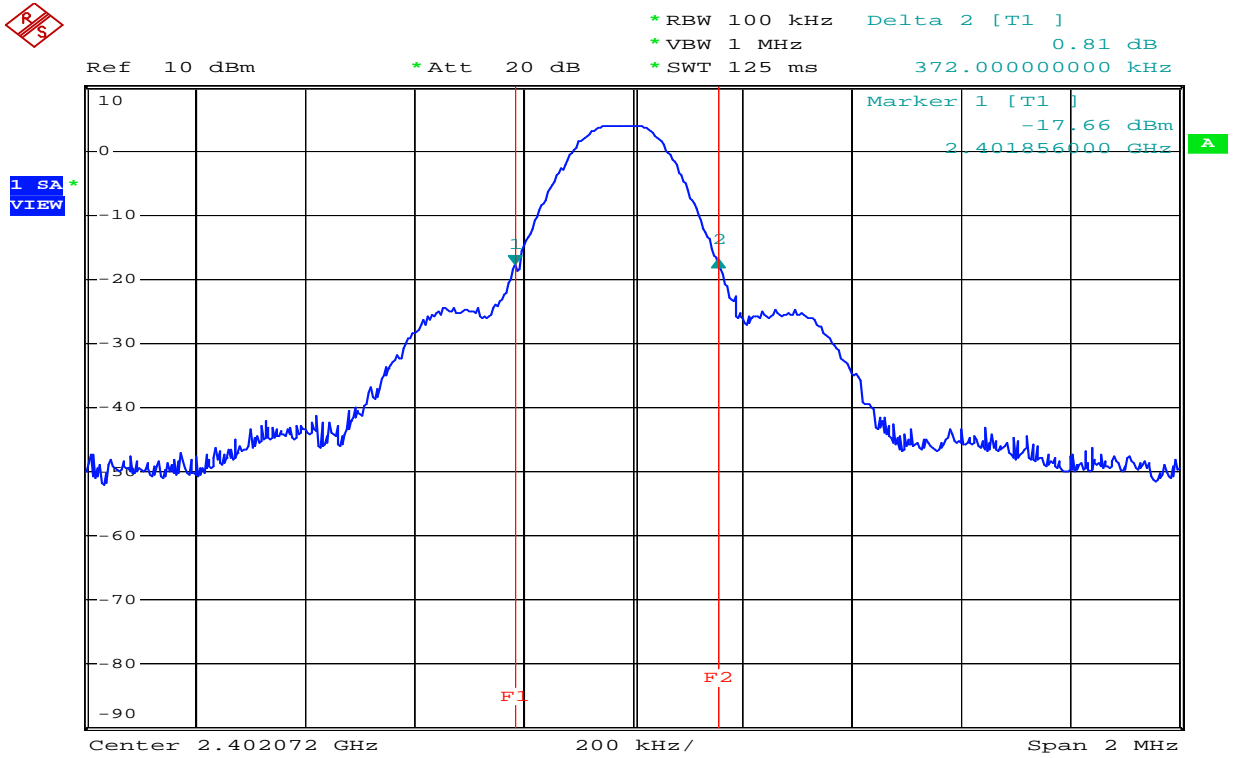

Date: 4.NOV.2006 16:14:19

#### CH1

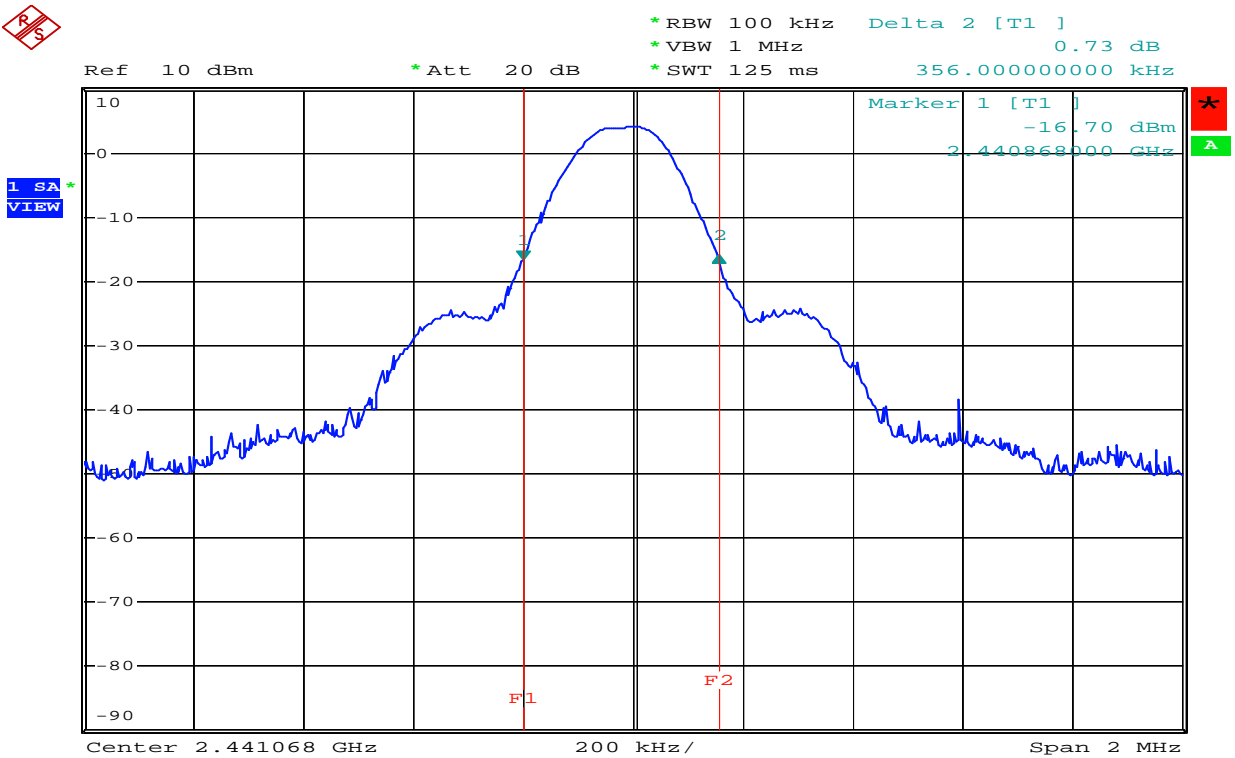

Date: 4.NOV.2006 16:12:10

#### CH40



Ref 10 dBm      \* Att 20 dB      \* RBW 100 kHz      Delta 2 [T1 ]  
\* VBW 1 MHz      0.15 dB  
\* SWT 125 ms      360.000000000 kHz

1 SA  
VIEW

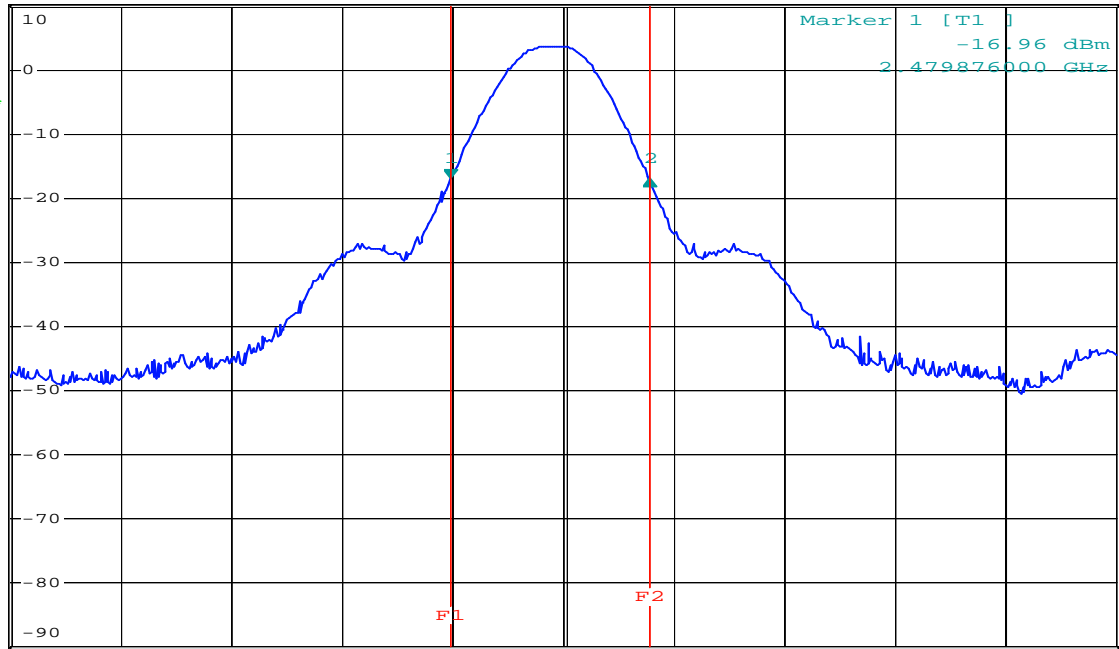

Center 2.48008 GHz      200 kHz/      Span 2 MHz

Date: 4.NOV.2006 17:33:55

CH79

## 8 MAXIMUM OUTPUT POWER MEASUREMENT

### 8.1 Measurement Equipment

Instrument	Manufacturer	Model	Serial No.	Last Calibration
Spectrum Analyzer	Agilent	8564EC	4046A00331	2006/03/27
Spectrum Analyzer	R&S	FSP30	100002	2005/11/07

Note: All instrument upon which need to be calibrated are within calibration period of 1 year.

### 8.2 Standard Applicable and limit

According to §15.247(b)(1) For frequency hopping systems operating in the 2400-2483.5MHz band employing at least 75 hopping channels and all frequency hopping systems in the 5725MHz-5850MHz band: 1 Watt (30dBm). For all other frequency hopping systems in the 2400-2483.5 MHz band: 0.125 watts (20.97dBm). The limitation has to be reduced by the amount in dB that the gains of the antenna exceed 6dBi. In case of point-to-point operation, the limit has to be reduced by 1dB for every 3dB that the directional gain of the antenna exceeds 6dBi.

### 8.3 Block Diagram of Test Configuration

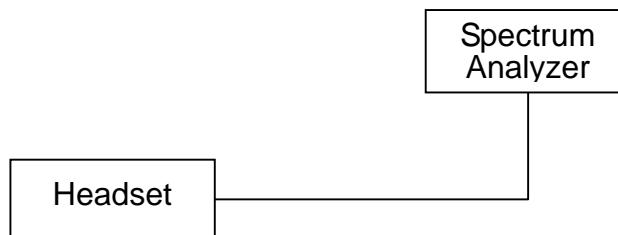

### 8.4 Measurement Instrument setting

Power Meter Parameter	Setting
Filter No.	Auto
Measurement time	0.135 s ~ 26 s
Used Peak Sensor	NRV-Z32 (model 04)

## **8.5 Configuration of Measurement**

- 8.5.1 Check the calibration of the measuring instrument using either an internal calibrator or a known signal from an external generator.
- 8.5.2 Position the EUT as shown in section 8.3 without connection to measurement instrument. Turn on the EUT and connect its antenna terminal to measurement instrument via a low loss cable. Then set it to any one measured frequency within its operating range and make sure the instrument is operated in its linear range.
- 8.5.3 Set RBW of spectrum analyzer to 100 KHz and VBW to 1 MHz.
- 8.5.4 Measure the highest amplitude appearing on spectral display and record the level to calculate result data.
- 8.5.5 Repeat above procedures until all frequencies measured were complete.

## MAXIMUM OUTPUT POWER MEASUREMENT

Ambient temperature : 26°C  
Relative humidity : 59%

(Test Mode: HEADSET)

Channel	Frequency (MHz)	Output Peak Power (dBm)	Max. Limit (dBm)
CH1	2402	4.49	30
CH40	2441	4.18	30
CH79	2480	4.06	30

**Note: 1. The expanded uncertainty of the output power tests is 2dB.**

### 8.6 Measurement waveform

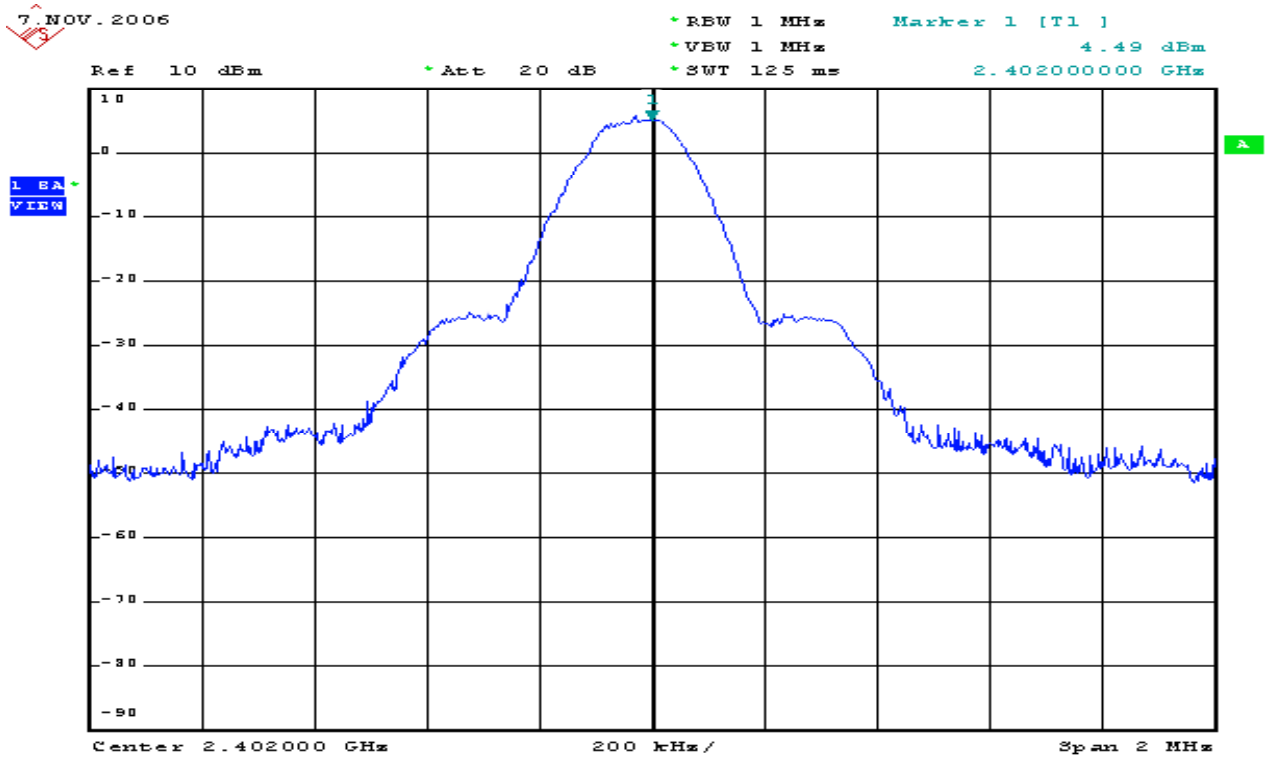

Date: 7.NOV.2006 16:09:07

CH1

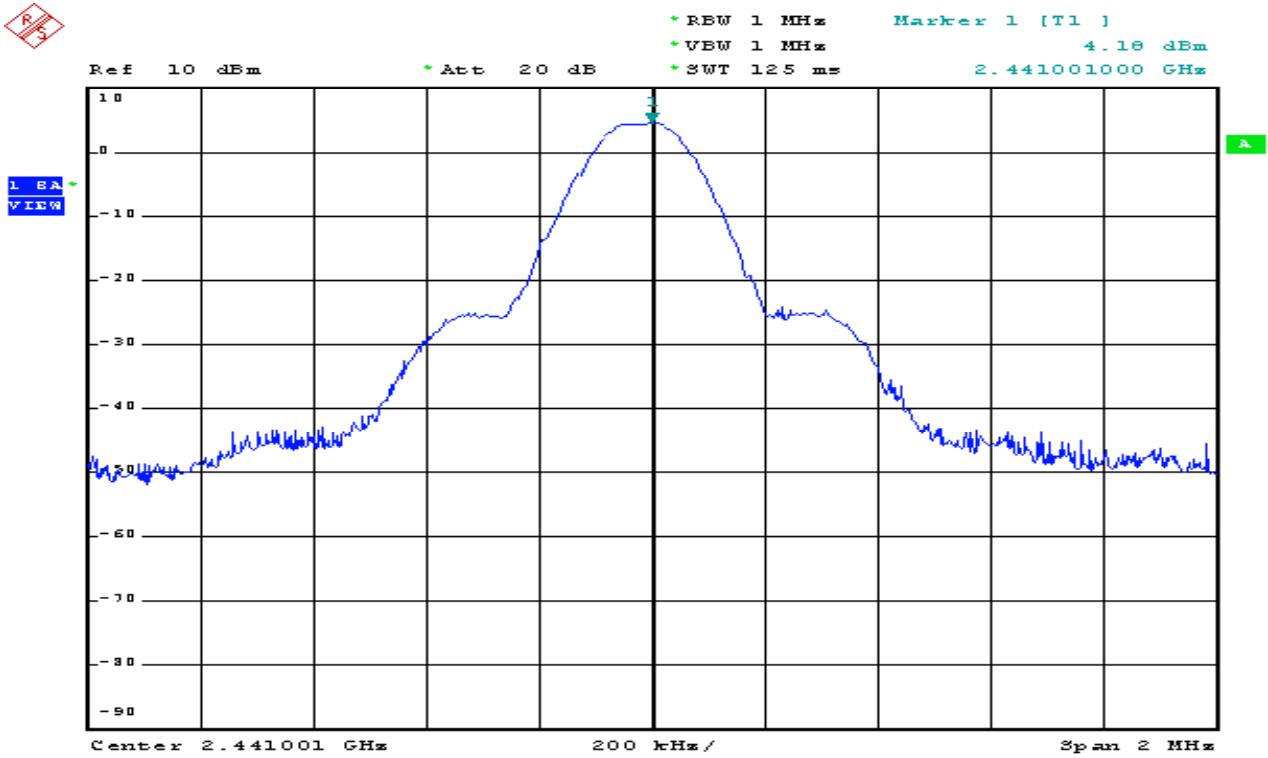

Date: 7.NOV.2006 16:12:03

CH40

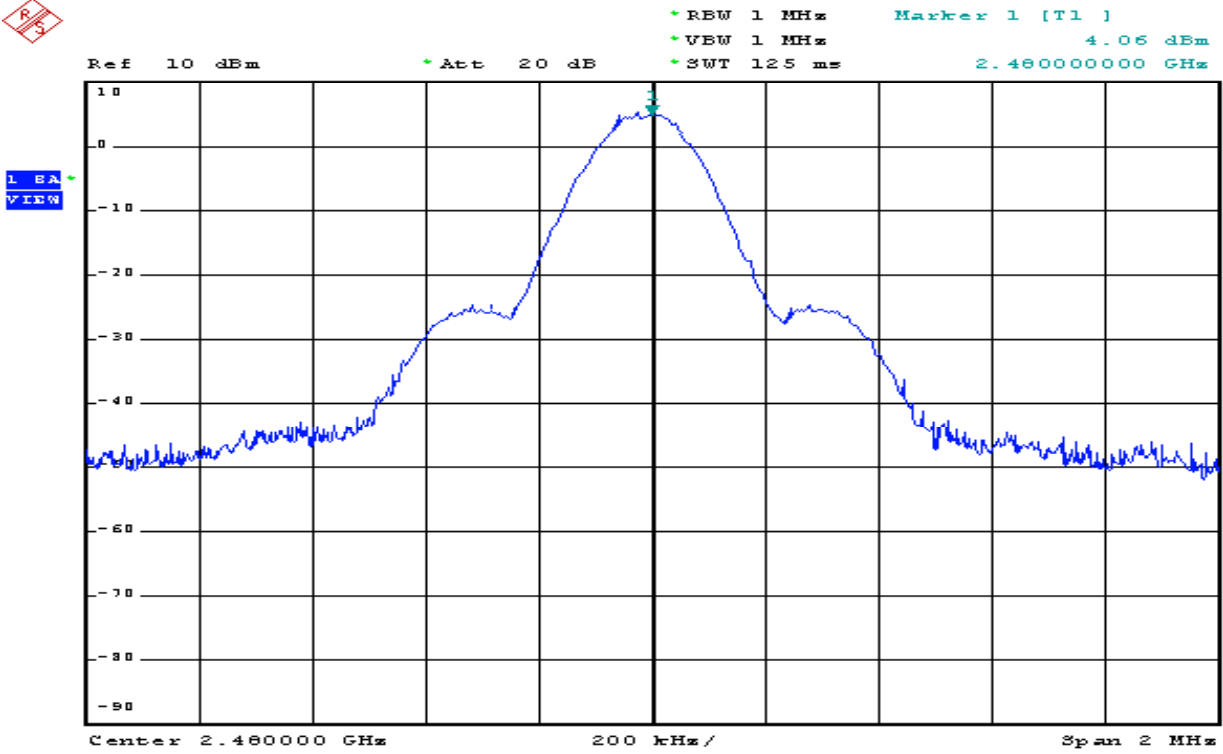

Date: 7.NOV.2006 16:14:55

CH79



## 9 100 kHz BANDWIDTH OF BAND EDGES MEASUREMENT

### 9.1 Instrument

Instrument	Manufacturer	Model	Serial No.	Last Calibration
Spectrum Analyzer	Rohde & Schwarz	FSP30	100002	2005/11/07

Note: All instrument upon which need to be calibrated are within calibration period of 1 year.

### 9.2 Standard Applicable

According to §15.247(d), if any 100 kHz bandwidth outside these frequency bands, the radio frequency power that is produced by the modulation products of the spreading sequence, the information sequence and the carrier frequency shall be either at least 20 dB below that in any 100 kHz bandwidth within the band that contains the highest level of the desired power or shall not exceed the general levels specified in § 15.209(a), whichever results in the lesser attenuation.

Frequencies (MHz)	Field Strength (microvolts/meter)	Measurement Distance (meters)
0.009~0.490	2400/F(KHz)	300
0.490~1.705	24000/F(KHz)	30
1.705~30.0	30	30
30~88	100	3
88~216	150	3
216~960	200	3
Above 960	500	3

### 9.3 Block Diagram of Test Configuration

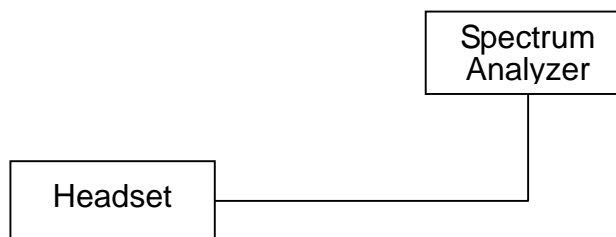

#### 9.4 Measuring Instrument Setting

Spectrum Parameter	Setting
Attenuation	20dB
Span Frequency	5 MHz
RB / VB (emission in restricted band)	1MHz / 1MHz for Peak, 1 MHz / 10Hz for Average
RB / VB (other emission)	100 KHz /100 KHz for Peak

#### 9.5 Configuration of Measurement

- 9.5.1 Check the calibration of the measuring instrument using either an internal calibrator or a known signal from an external generator.
- 9.5.2 Position the EUT as shown in section 9.3 without connection to measurement instrument. Turn on the EUT and connect its antenna terminal to measurement instrument via a low loss cable. Then set it to any one measured frequency within its operating range and make sure the instrument is operated in its linear range.
- 9.5.3 Set both RBW and VBW of spectrum analyzer to 30 kHz with a convenient frequency span including 100kHz bandwidth from band edge.
- 9.5.4 Measure the highest amplitude appearing on spectral display and set it as a reference level. Plot the graph with marking the highest point and edge frequency.
- 9.5.5 Repeat above procedures until all measured frequencies were complete.

### 100 kHz BANDWIDTH OF BAND EDGES MEASUREMENT

Ambient temperature : 26°C  
 Relative humidity : 59%

	FREQUENCY (MHz)	Reading (mV)	Cable Loss (mV)	Adjusted (mV)	Limit (mV)	Result
CH1	2402.000	331.962	20.41	352.372	N/A	N/A
F BE	2401.840	2.382	17.50	19.882	24.465	PASS

**FL 2.480650GHz < 2483.5GHz**

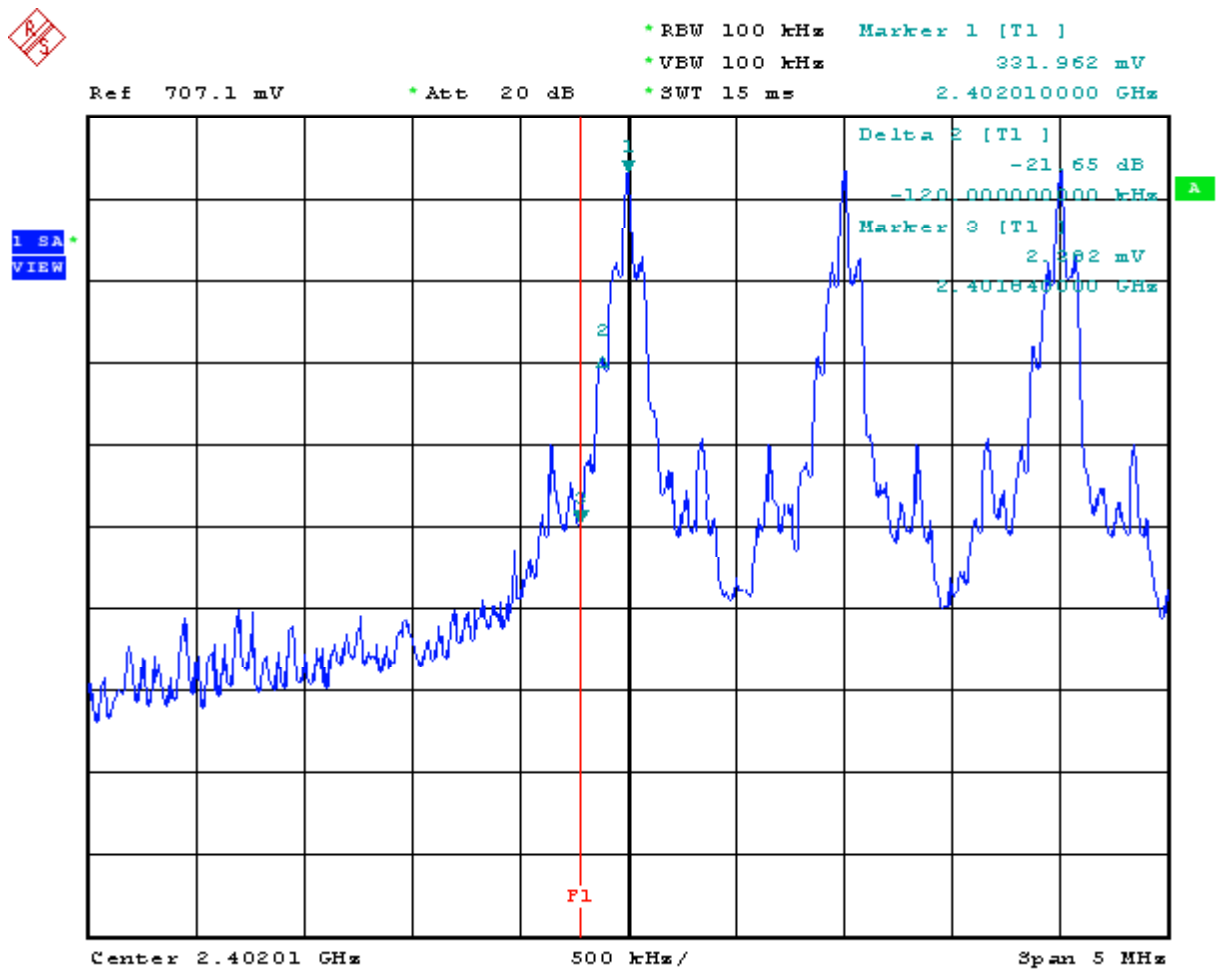

Date: 9.NOV.2006 14:48:16

CH1

	FREQUENCY (MHz)	Reading (mV)	Cable Loss (dBuV)	Adjusted (dBuV)	Limit (mV)	Result
CH79	2480.000	322.438	19.249	341.687	N/A	N/A
F BE	2480.250	4.443	18.891	23.334	27.261	PASS

**FL 2.480650GHz < 2483.5GHz**

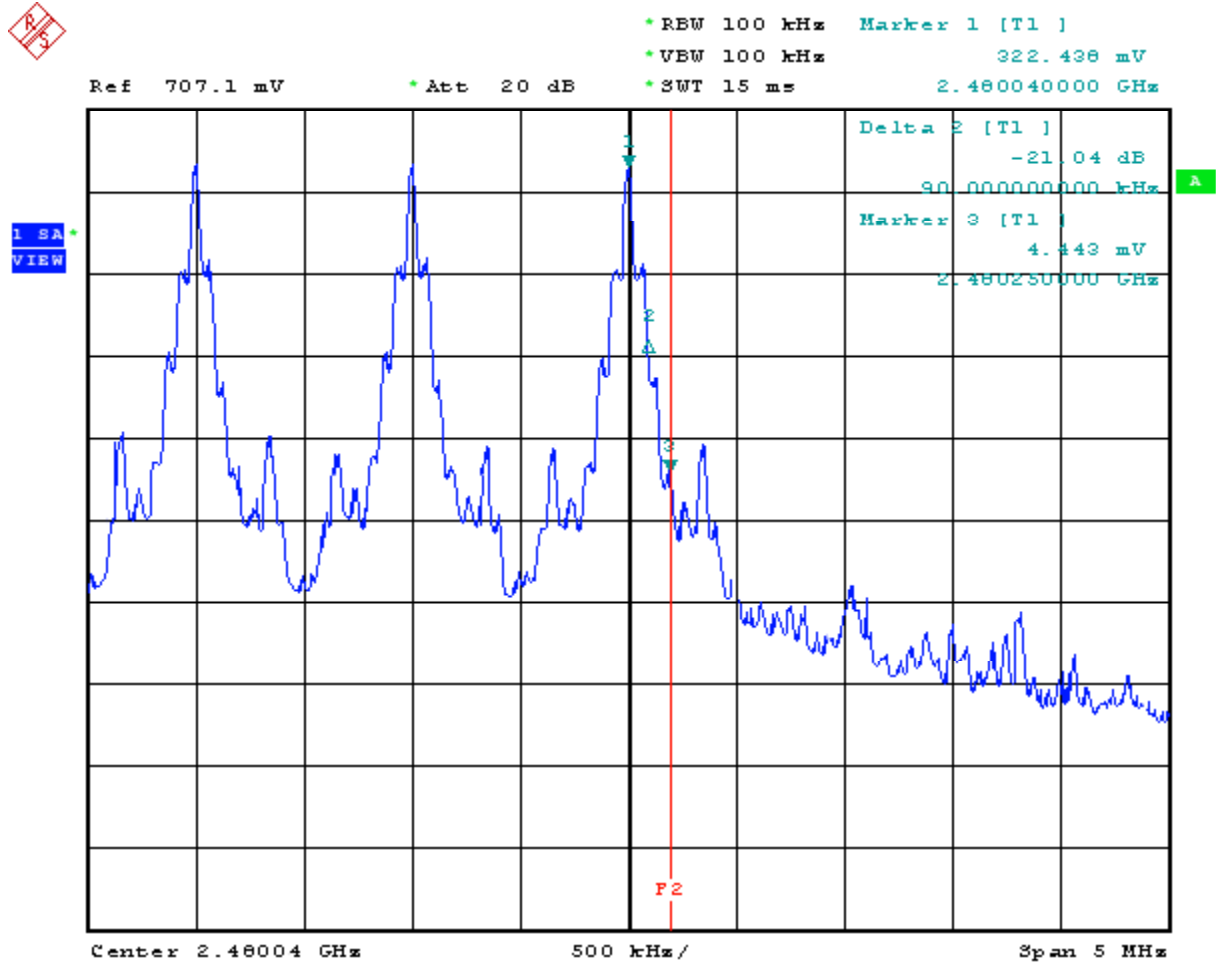

Date: 9.NOV.2006 14:42:29

**CH79**

Note: 1. The expanded uncertainty of the 100 kHz bandwidth of band edges tests is 2dB

## 10 HOPPING CHANNEL SEPARATION

### 10.1 Instrument

Instrument	Manufacturer	Model	Serial No.	Last Calibration
Spectrum Analyzer	Rohde & Schwarz	FSP30	100002	2005/11/07

Note: All instrument upon which need to be calibrated are within calibration period of 1 year.

### 10.2 Standard Applicable

According to §15.247(a)(1), frequency hopping system shall have, hopping channel carrier frequencies separated by a minimum of 25 kHz or the 20 dB bandwidth of the hopping channel, whichever is greater.

### 10.3 Block Diagram of Test Configuration

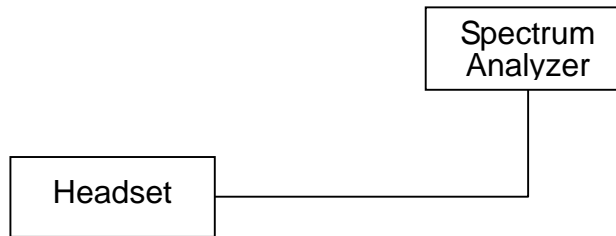

### 10.4 Measuring Instrument Setting

Spectrum Parameter	Setting
Attenuation	20dB
Span Frequency	> Measurement Bandwidth or Channel Separation
RB	30 kHz (20dB Bandwidth) / 1MHz (Channel Separation)
VB	30 KHz (20dB Bandwidth) / 1MHz (Channel Separation)
Detector	Peak
Trace	Max Hold
Sweep Time	15ms

## **10.5 Configuration of Measurement**

- 10.5.1 Check the calibration of the measuring instrument using either an internal calibrator or a known signal from an external generator.
- 10.5.2 Position the EUT as shown in section 10.3 without connection to measurement instrument. Turn on the EUT and connect it to measurement instrument. Then set it to any one convenient frequency within its operating range.
- 10.5.3 By using the MaxHold function record the separation of two adjacent channels.
- 10.5.4 Measure the frequency difference of these two adjacent channels by SA MARK function.
- 10.5.5 And then plot the result on SA screen.
- 10.5.6 Repeat above procedures until all frequencies measured were complete.

## HOPPING CHANNEL SEPARATION

Ambient temperature : 26°C  
Relative humidity : 59%

Channel	Frequency (MHz)	Adjacent Hopping Channel Separation (kHz)	Max. Limit (kHz)
CH1-CH2	2402-2402.992	1002	>25
CH39-40	2440-2441	1002	>25
CH79-80	2479-2480	996	>25

Note: 1. The expanded uncertainty of the hopping channel separation tests is 2dB

### 10.6 Measurement waveform

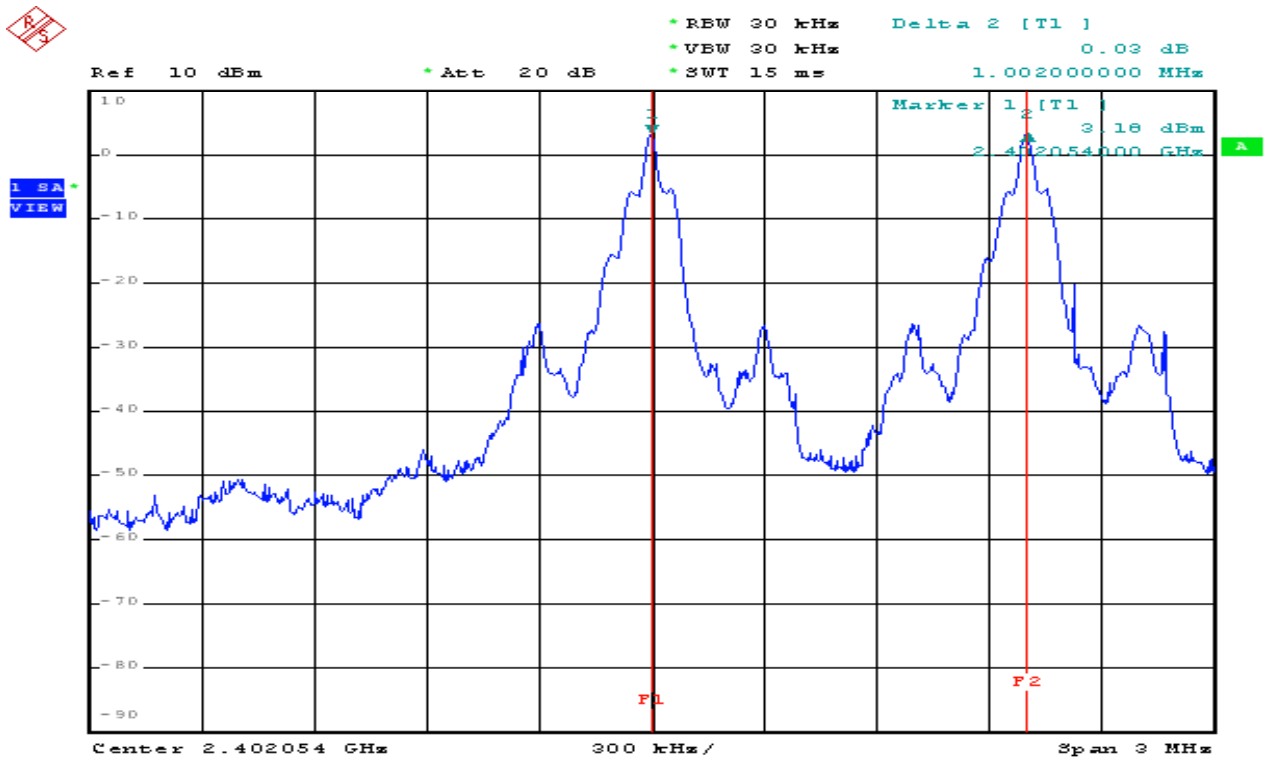

Date: 4.NOV.2006 16:33:07

### CH1-CH2

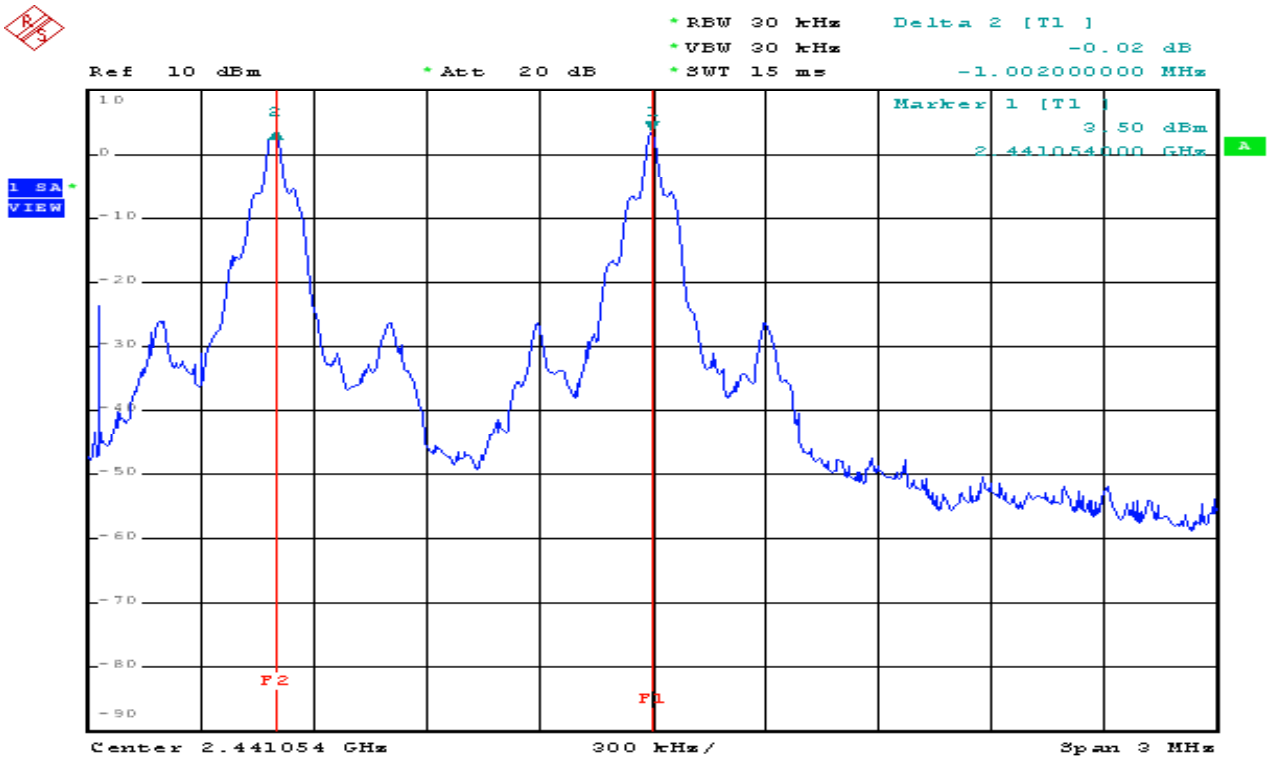

Date: 4.NOV.2006 16:35:15

### CH39-CH40



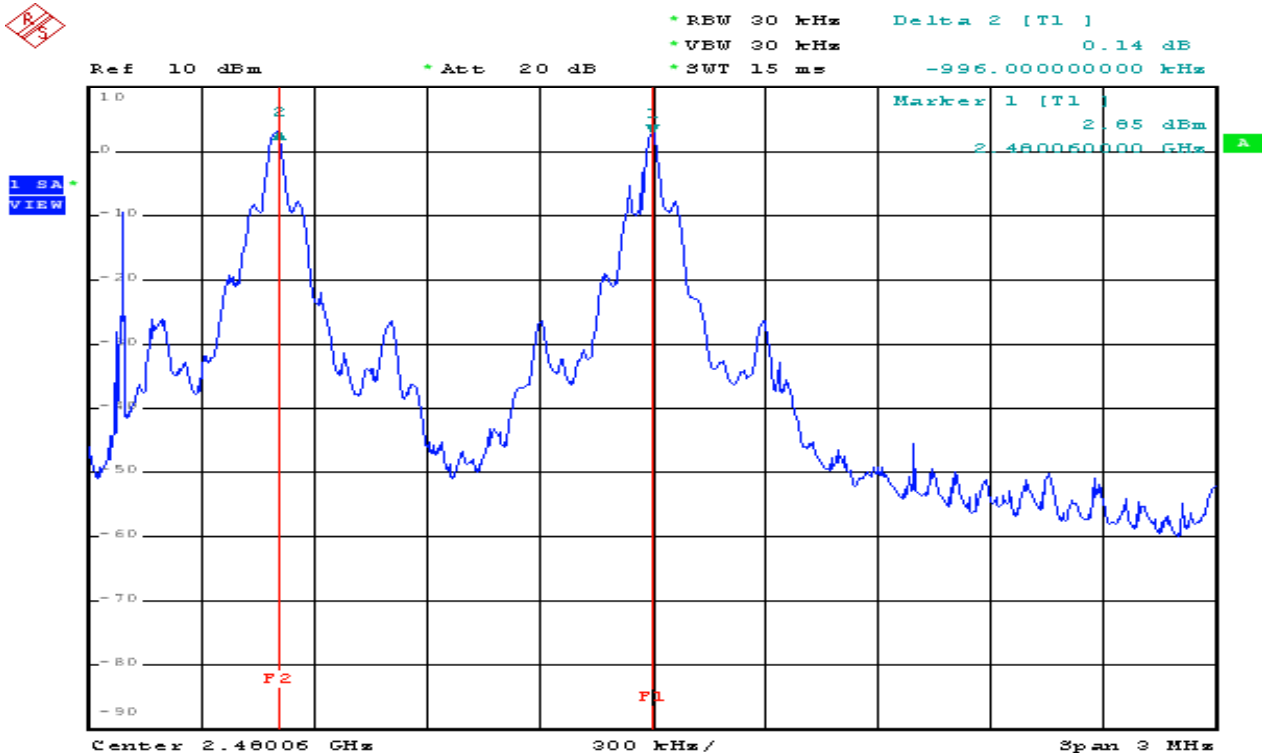

Date: 4.NOV.2006 16:41:23

CH78-CH79

## 11 NUMBER OF HOPPING FREQUENCY USED

### 11.1 Instrument

Instrument	Manufacturer	Model	Serial No.	Last Calibration
Spectrum Analyzer	Rohde & Schwarz	FSP30	100002	2005/11/07

Note: All instrument upon which need to be calibrated are within calibration period of 1 year.

### 11.2 Standard Applicable and limit

According to §15.247(b)(1) (iii), for frequency hopping system operating in the 2400-2483.5 MHz bands shall use at least 75 non-overlapping hopping channels.

### 11.3 Block Diagram of Test Configuration

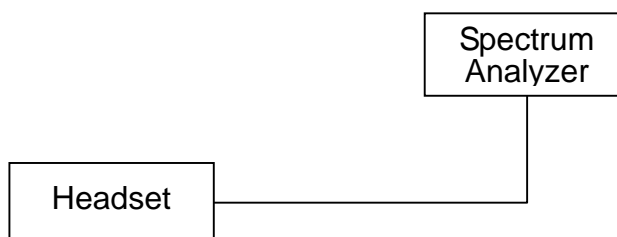

### 11.4 Measuring Instrument Setting

Spectrum Parameters	Setting
Attenuation	20dB
Span Frequency	> Operating Frequency Range
RB	100 KHz
VB	100 KHz
Detector	Peak
Trace	Max Hold
Sweep Time	15ms

## 11.5 Configuration of Measurement

- 11.5.1 Check the calibration of the measuring instrument (SA) using either an internal calibrator or a known signal from an external generator.
- 11.5.2 Position the EUT as shown in section 11.3 without connection to measurement instrument. Turn on the EUT and connect its antenna terminal to measurement instrument via a low loss cable. Then set it to any one measured frequency within its operating range and make sure the instrument is operated in its linear range.
- 11.5.3 Set the SA on Max Hold Mode, and then keep the EUT in hopping mode. Record all the signals from each channel until each one has been recorded.
- 11.5.4 Set the SA on View mode and then plot the result on SA screen.
- 11.5.5 Repeat above procedures until all frequencies measured were complete.

### MEASUREMENT DATA

Ambient temperature : 26°C

Relative humidity : 59%

Modulation Type:

Channel	Frequency (MHz)	Hopping Channel (Channels)
CH1-CH79	2.402-2.480	79

**Note: 1. The expanded uncertainty of number of hopping frequency used tests is 2dB.**

### 11.6 Measurement waveform

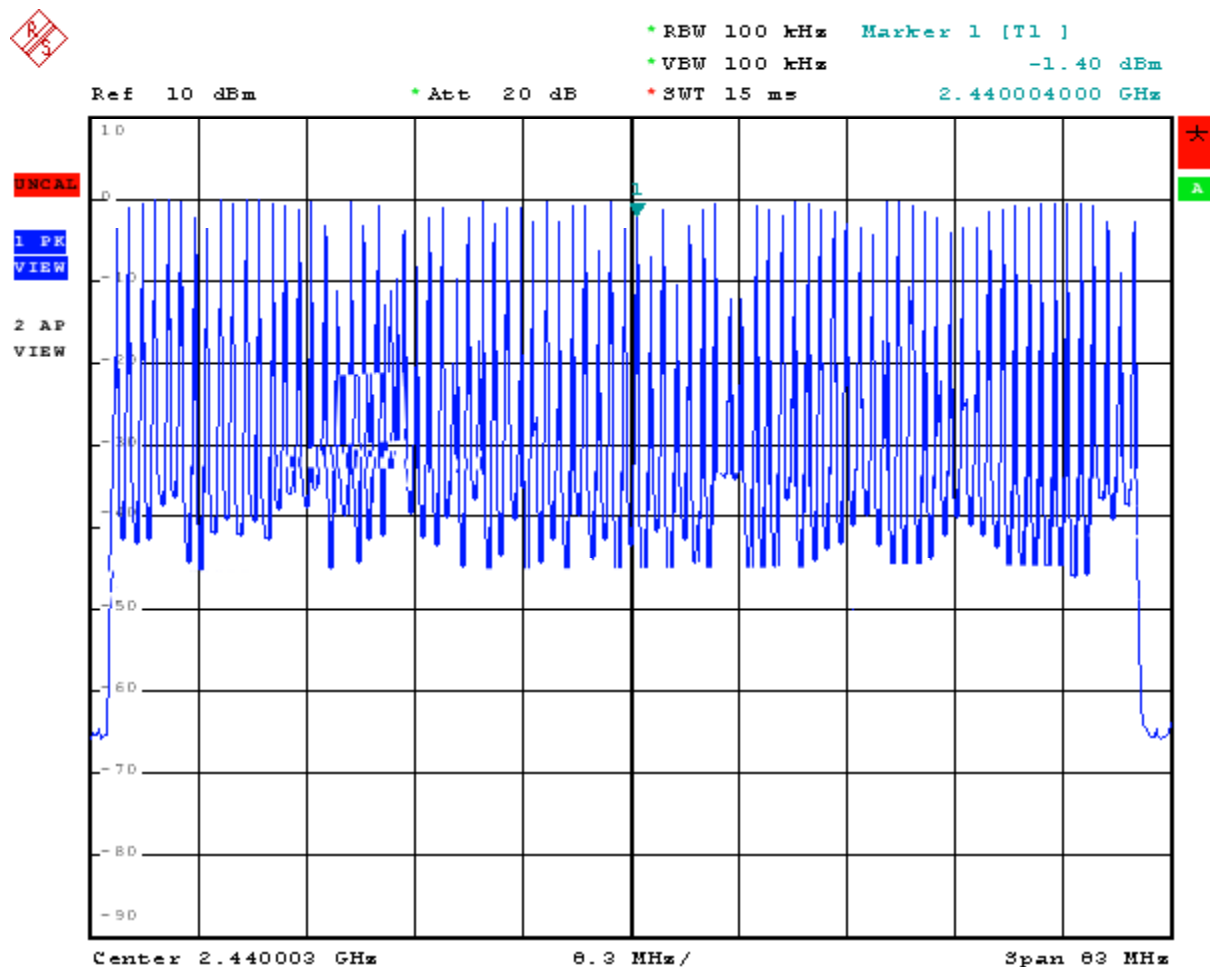

Date: 9.NOV.2006 11:22:59

## 12 DWELL TIME ON EACH CHANNEL

### 12.1 Instrument

Instrument	Manufacturer	Model	Serial No.	Last Calibration
Spectrum Analyzer	Rohde & Schwarz	FSP30	100002	2005/11/07

Note: All instrument upon which need to be calibrated are within calibration period of 1 year.

### 12.2 Standard Applicable and limit

According to §15.247(a)(1)(iii), for frequency hopping system operating in the 2400-2483.5 MHz band shall use at least 15 non-overlapping channels. The average time of occupancy on any frequency shall not be greater than 0.4 second within a period of 0.4 seconds multiplied by the number of hopping channels employed

### 12.3 Block Diagram of Test Configuration

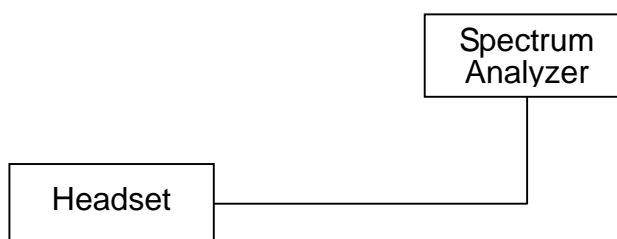

### 12.4 Measuring Instrument Setting

Spectrum Parameter	Setting
Attenuation	40dB
Span Frequency	0 MHz
RB	1000 kHz
VB	1000 kHz
Detector	Peak
Trace	View

## 12.5 Configuration of Measurement

- 12.5.1 Check the calibration of the measuring instrument using either an internal calibrator or a known signal from an external generator.
- 12.5.2 Position the EUT as shown in figure 4 without connection to measurement instrument. Turn on the EUT and connect its antenna terminal to measurement instrument via a low loss cable. Then set it to any one measured frequency within its operating range and make sure the instrument is operated in its linear range.
- 12.5.3 Adjust the center frequency of SA on any frequency be measured and set SA to zero span mode. And then, set RBW and VBW of spectrum analyzer to proper value.
- 12.5.4 Measure the time duration of one transmission on the measured frequency. And then plot the result with time difference of this time duration.
- 12.5.5 Repeat above procedures until all frequencies measured were complete.

### DWELL TIME ON EACH CHANNEL MEASUREMENT DATA

Ambient temperature : 26°C

Relative humidity : 59%

The period is 0.4(Sec) \* 79(channels) = 31.6 sec

Dwell Time =Time slot length \* Hop rate / 79channel \* 31.6

DATA PACKET	Frequency (MHz)	Time slot length (ms)	Hop rate	Dwell time (s)	Limit (s)	Test Result
DH1	2402	0.50	667	0.13	<0.4	Complies
DH3	2402	0.54	285	0.06	<0.4	Complies
DH5	2402	3.21	160	0.20	<0.4	Complies
DH1	2441	0.52	667	0.13	<0.4	Complies
DH3	2441	0.55	285	0.06	<0.4	Complies
DH5	2441	3.09	160	0.23	<0.4	Complies
DH1	2480	0.53	667	0.14	<0.4	Complies
DH3	2480	0.49	285	0.05	<0.4	Complies
DH5	2480	3.04	160	0.19	<0.4	Complies

**Note: 1. The expanded uncertainty of dwell time on each channel tests is 2dB.**



### 12.6 Measurement waveform

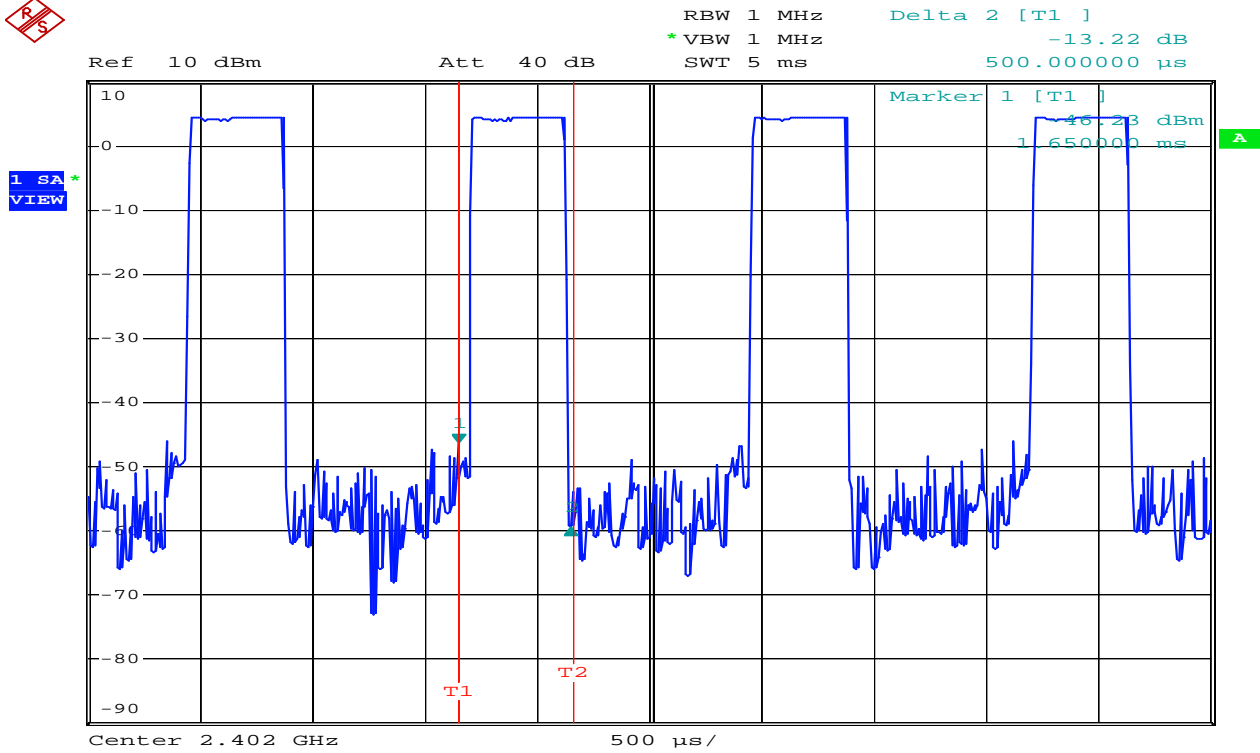

Date: 4.NOV.2006 17:03:01

### CH1 DH1

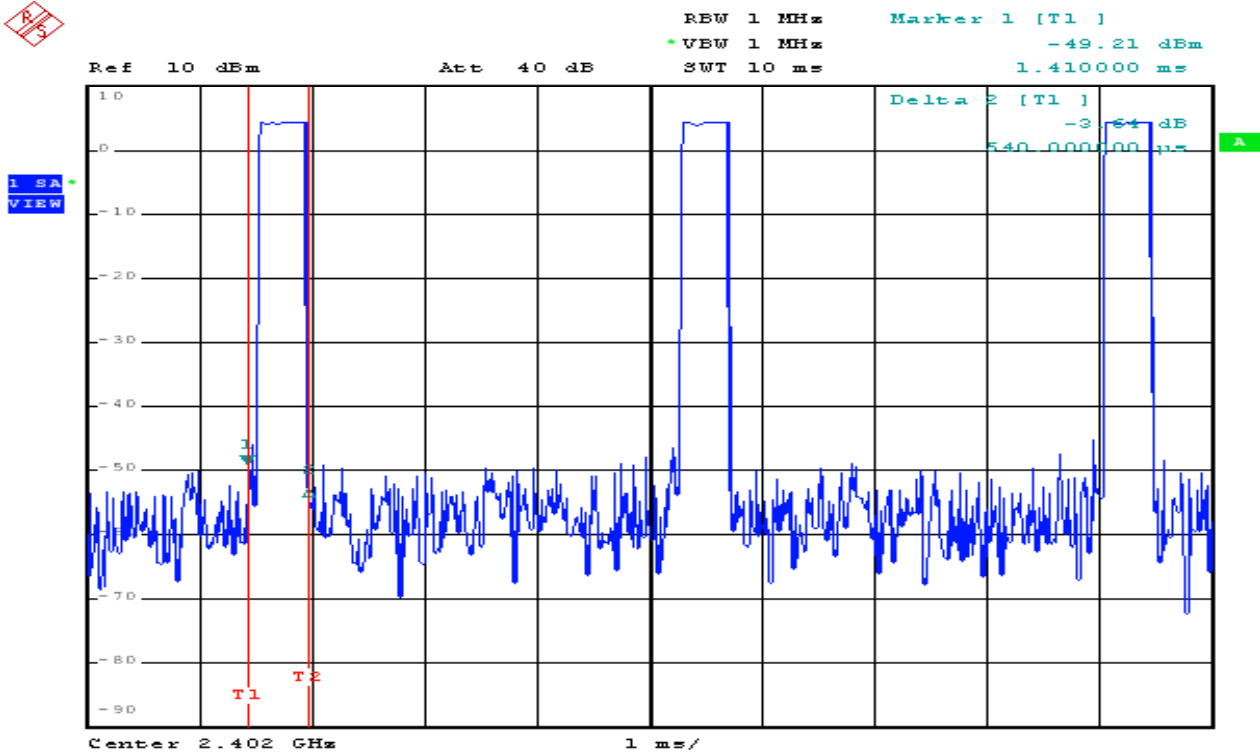

Date: 4.NOV.2006 17:04:40

### CH1 DH3

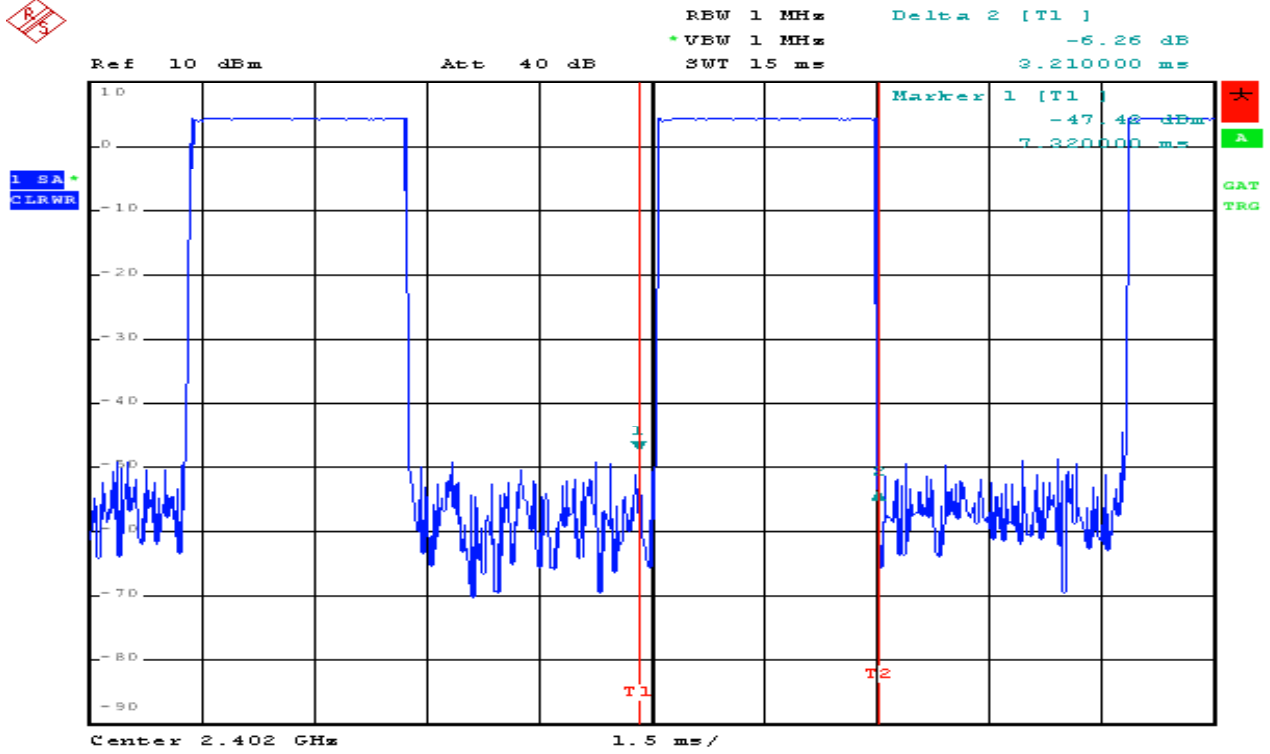

Date: 4.NOV.2006 17:10:07

CH1 DH5

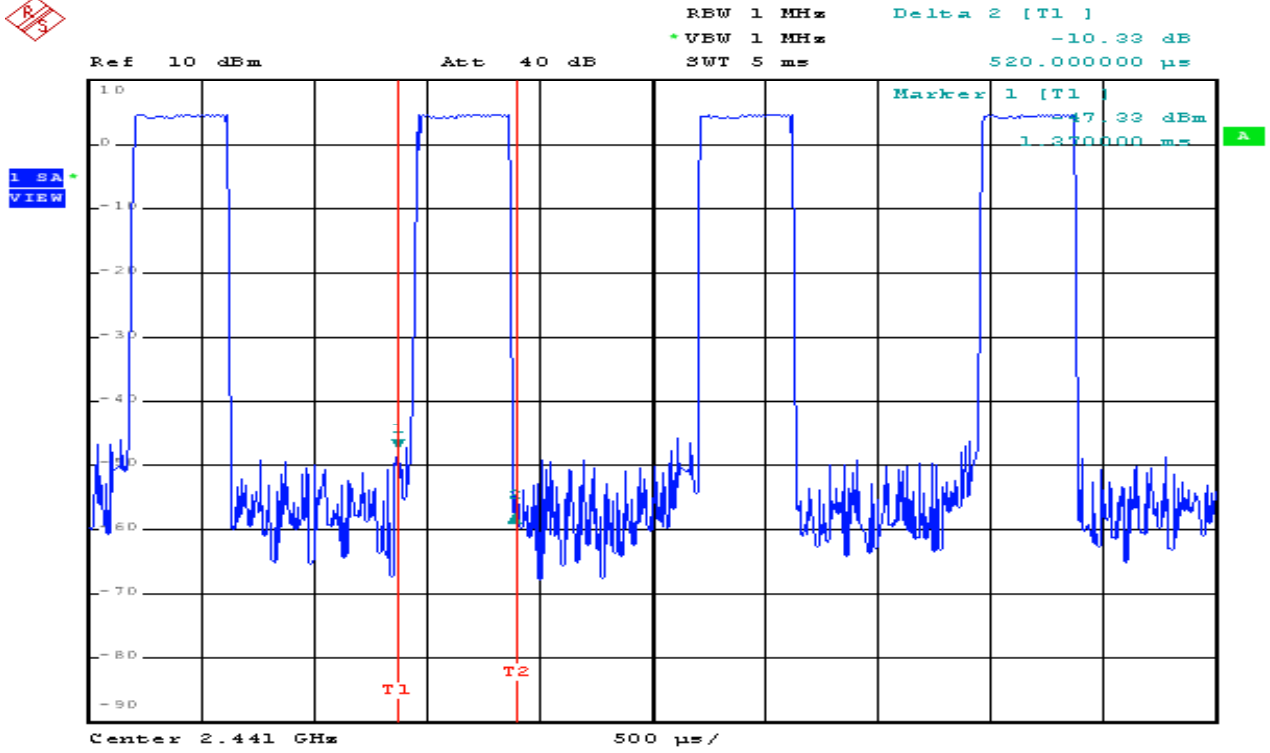

Date: 4.NOV.2006 17:15:09

### CH40 DH1

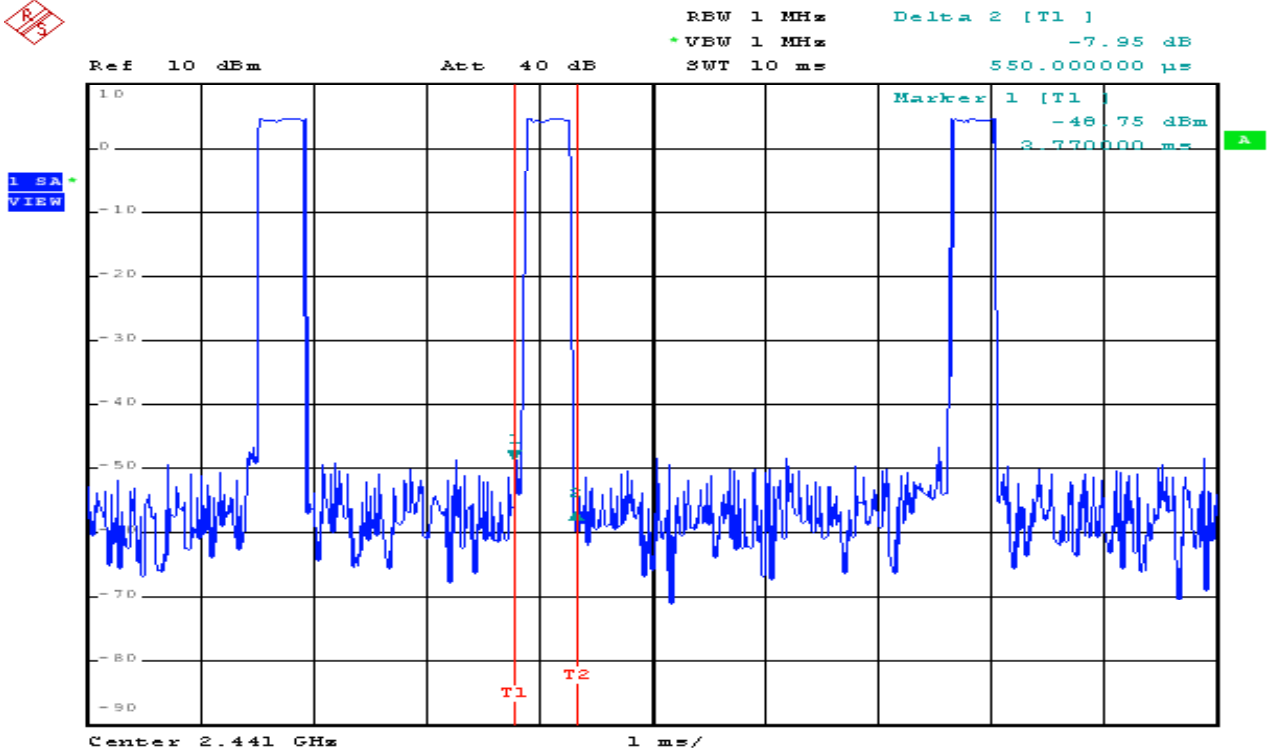

Date: 4.NOV.2006 17:13:36

### CH40 DH3

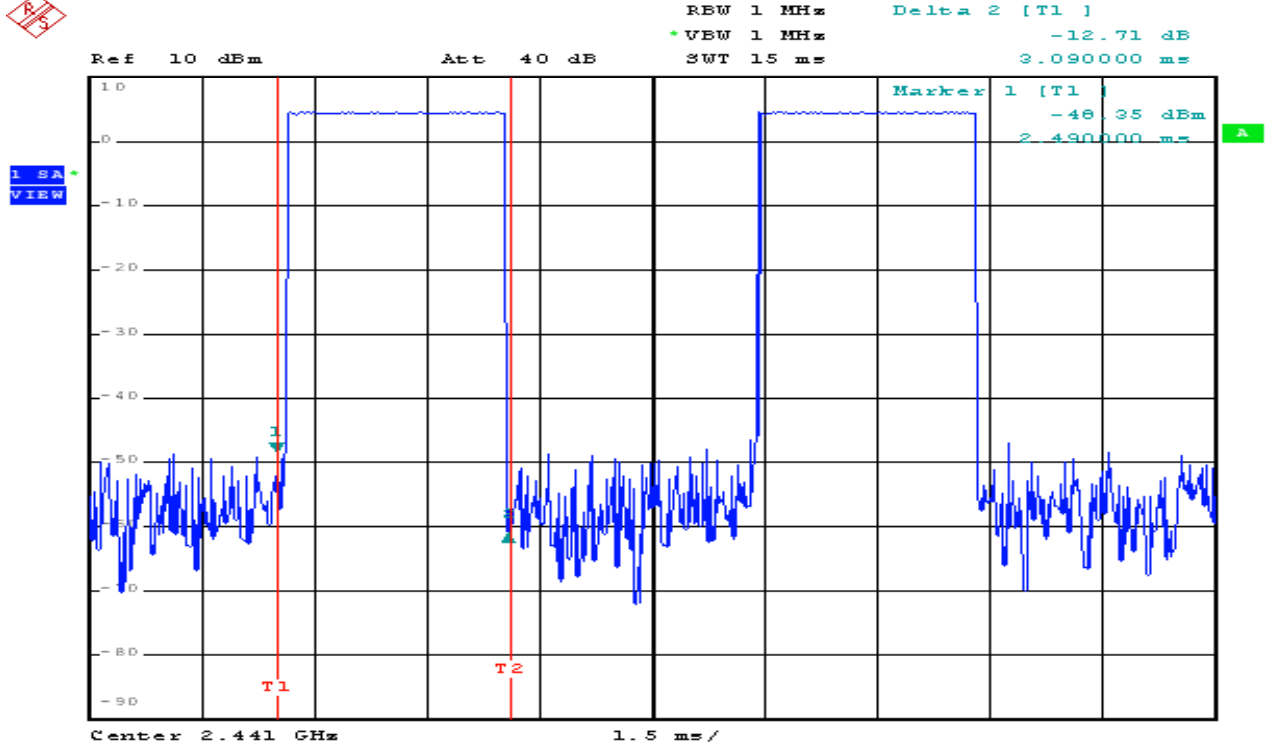

Date: 4.NOV.2006 17:11:57

CH40 DH5

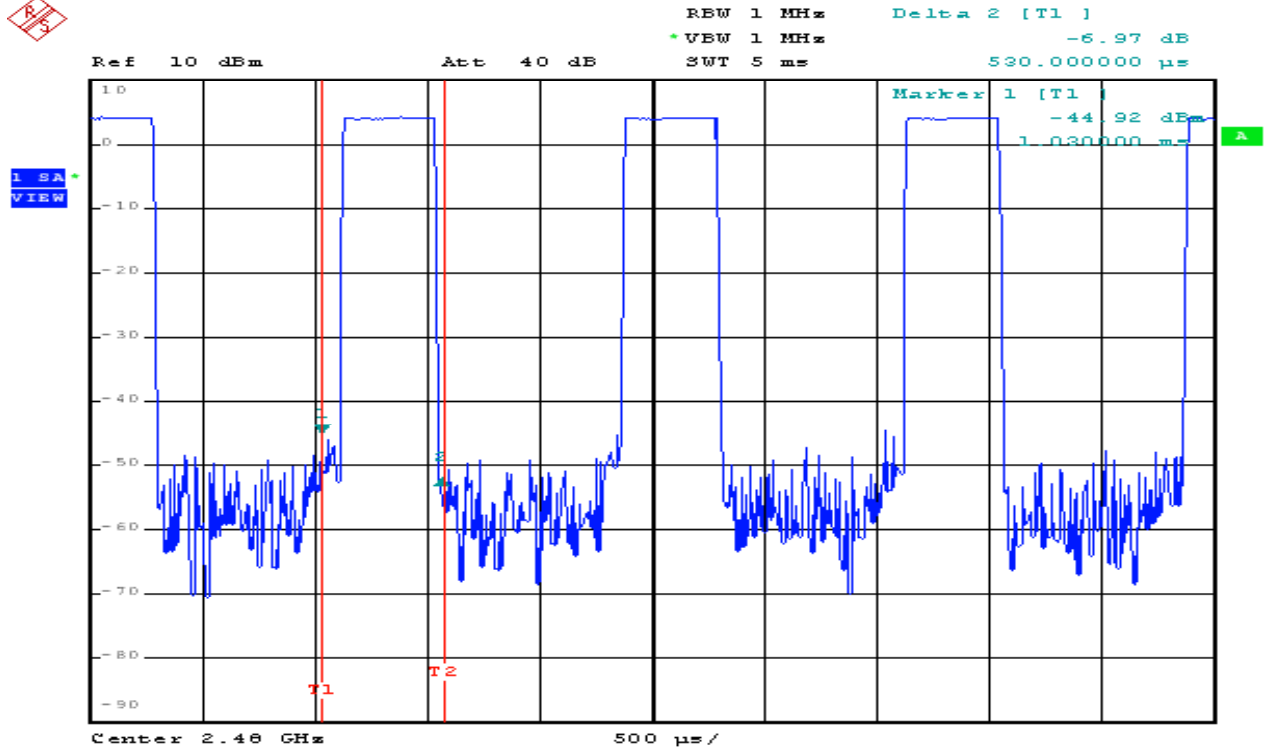

Date: 4.NOV.2006 17:18:50

### CH79 DH1

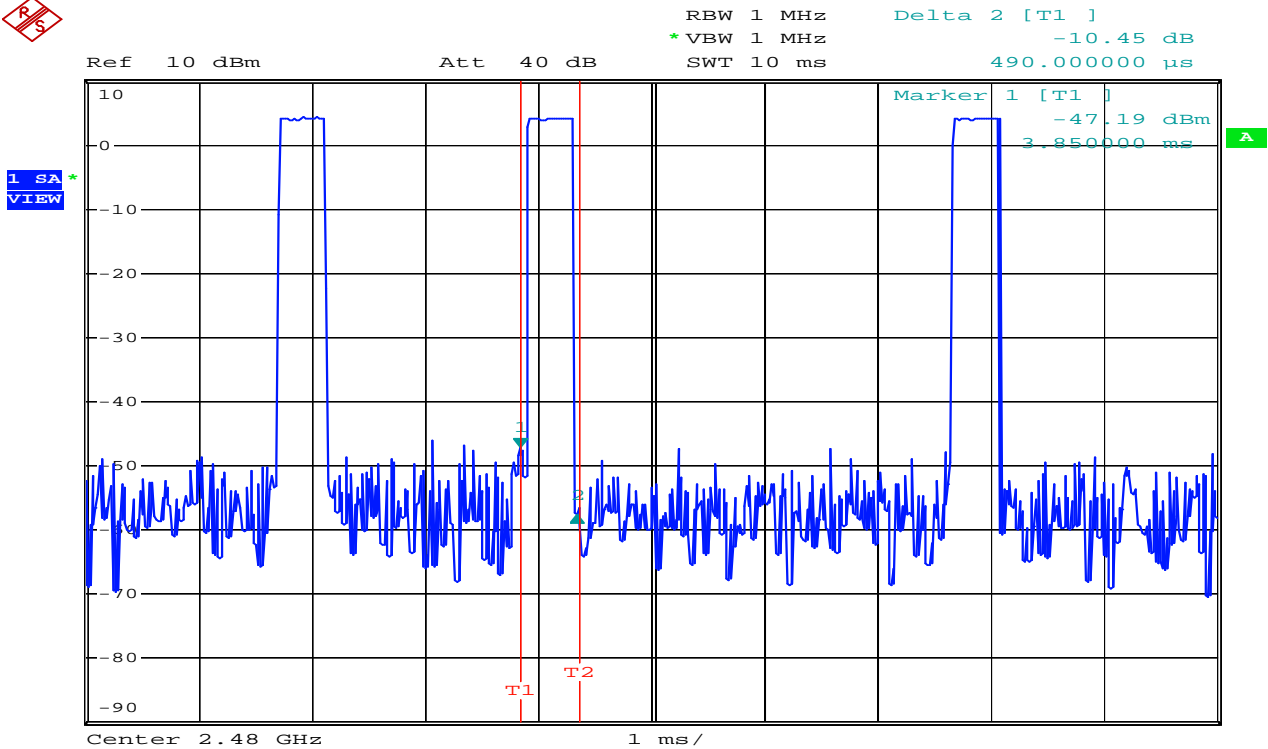

Date: 4.NOV.2006 17:24:06

### CH79 DH3



Ref 10 dBm Att 40 dB RBW 1 MHz Delta 2 [T1 ]  
\*VBW 1 MHz -21.14 dB  
SWT 15 ms 3.040000 ms

1 SA  
VIEW

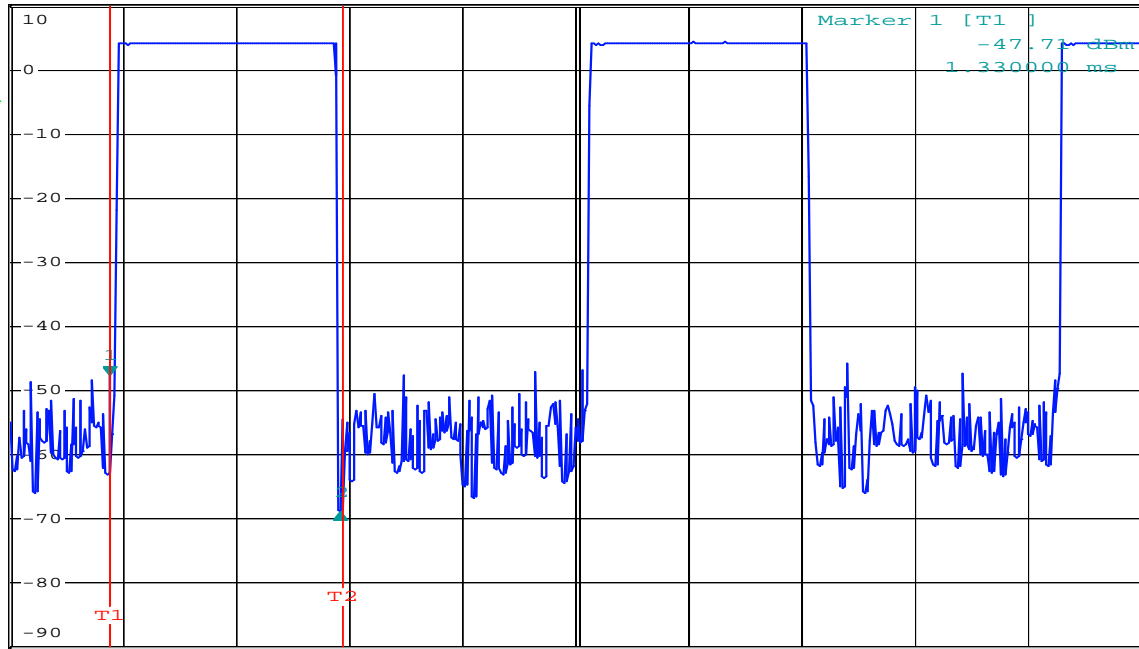

Date: 4.NOV.2006 17:25:40

CH79 DH5

### **13 HOPPING SEQUENCE TEST**

**79 hopping sequence in data mode:**

**CH= (2402+N)-2402; N=0-78**