



Engineering Solutions & Electromagnetic Compatibility Services

**FCC & IC Certification Report**

**4RF Limited**  
**26 Glover Street, Ngauranga**  
**PO Box 13-506**  
**Wellington 6032**  
**New Zealand**  
**Contact: Paul Young**

**Aprisa SR+**  
**Model SQ400M131**

**FCC ID: UIPSQ400M131**  
**IC: 6772A-SQ400M131**

**November 21, 2013**

<b>Standards Referenced for this Report</b>	
FCC Part 2	Frequency Allocations and Radio Treaty Matters; General Rules and Regulations (10-01-12)
FCC Part 90	Private Land Mobile Radio Services (10-01-12)
RSS-119 Issue 11	Land Mobile and Fixed Radio Transmitters and Receivers Operating in the Frequency Range 27.41- 960 MHz
SRSP-501; Issue 5 October 2004	Technical Requirements for Land Mobile and Fixed Radio Services Operating in the Bands 406.1-430 MHz and 450-470 MHz
ANSI TIA-603-C-2004	Land Mobile FM or PM Communications Equipment Measurement and Performance Standards

<b>Frequency Range (MHz)</b>	<b>Transmit Power Conducted (W)</b>	<b>Measured Frequency Tolerance (ppm)</b>	<b>Emission Designator</b>
406.1-420, 421-430, 450-470 (FCC) 406.1-430, 450-470 (IC)	0.01 – 5.0	1.3	10K5D7W
406.1-420, 421-430, 450-470 (FCC) 406.1-430, 450-470 (IC)	0.01 – 5.0	1.3	19K3D7W

**Report Prepared by Test Engineer: Daniel W. Baltzell**

Document Number: 2013202

*This report may not be reproduced, except in full, without the full written approval of Rhein Tech Laboratories, Inc. and 4RF Limited. Test results relate only to the item tested.*

*These tests are accredited and meet the requirements of ISO/IEC 17025 as verified by ANSI-ASQ National Accreditation Board/ACLASS. Refer to certificate and scope of accreditation AT-1445.*

## Table of Contents

---

1	Test Result Summary .....	6
2	General Information .....	6
2.1	Test Facility .....	6
2.2	Tested System Details .....	6
3	FCC Part 2.1033(c)(8) Voltages and Currents Through The Final Amplifying Stage .....	8
4	FCC Part 2.1046(a): RF Power Output: Conducted, Part 90.541(b)/90.542(a)(6); IC RSS-119 4.1 ..	8
4.1	Test Procedure .....	8
4.2	Test Data .....	8
5	FCC Part 2.1051, 90.210: Conducted Spurious Emissions .....	9
5.1	Test Procedure .....	9
5.2	Test Data .....	9
6	FCC Part 90.210(g), 2.1053(a): Field Strength of Spurious Radiation; IC RSS-119 5.8.9.2 .....	46
6.1	Test Procedure .....	46
6.2	Test Data .....	46
7	FCC Part 2.1049(c)(1), 90.210: Occupied Bandwidth; IC RSS-119 5.5 .....	51
7.1	Test Procedure .....	51
7.2	Test Data .....	52
8	FCC Part 2.1055, 90.213: Frequency Stability; IC RSS-119 5.3 .....	64
8.1	Test Procedure .....	64
8.2	Test Data .....	64
8.2.1	Temperature Frequency Stability .....	64
8.2.2	Frequency Stability/Voltage Variation .....	65
9	FCC Rules and Regulations Part 90.214; RSS-119 5.9: Transient Frequency Response .....	67
9.1	Test Procedure .....	67
10	FCC Part 2.1047: Modulation Characteristics; IC RSS-119 5.8 Types of Modulation .....	92
11	FCC Part 2.1049: Occupied Bandwidth; IC RSS-Gen Occupied Bandwidth .....	93
11.1	Bandwidth Test Procedure .....	93
11.2	Bandwidth Test Data .....	93
12	Conclusion .....	106

**Table of Plots**

Plot 5-1:	Conducted Spurious Emissions – 406.1 MHz; Narrowband; QPSK .....	10
Plot 5-2:	Conducted Spurious Emissions – 406.1 MHz; Narrowband; 16QAM .....	11
Plot 5-3:	Conducted Spurious Emissions – 406.1 MHz; Narrowband; 64QAM .....	12
Plot 5-4:	Conducted Spurious Emissions – 406.1 MHz; Wideband; QPSK .....	13
Plot 5-5:	Conducted Spurious Emissions – 406.1 MHz; Wideband; 16QAM .....	14
Plot 5-6:	Conducted Spurious Emissions – 406.1 MHz; Wideband; 64QAM .....	15
Plot 5-7:	Conducted Spurious Emissions – 418 MHz; Narrowband; QPSK .....	16
Plot 5-8:	Conducted Spurious Emissions – 418 MHz; Narrowband; 16QAM .....	17
Plot 5-9:	Conducted Spurious Emissions – 418 MHz; Narrowband; 64QAM .....	18
Plot 5-10:	Conducted Spurious Emissions – 418 MHz; Wideband; QPSK .....	19
Plot 5-11:	Conducted Spurious Emissions – 418 MHz; Wideband; 16QAM .....	20
Plot 5-12:	Conducted Spurious Emissions – 418 MHz; Wideband; 64QAM .....	21
Plot 5-13:	Conducted Spurious Emissions – 430 MHz; Narrowband; QPSK .....	22
Plot 5-14:	Conducted Spurious Emissions – 430 MHz; Narrowband; 16QAM .....	23
Plot 5-15:	Conducted Spurious Emissions – 430 MHz; Narrowband; 64QAM .....	24
Plot 5-16:	Conducted Spurious Emissions – 430 MHz; Wideband; QPSK .....	25
Plot 5-17:	Conducted Spurious Emissions – 430 MHz; Wideband; 16QAM .....	26
Plot 5-18:	Conducted Spurious Emissions – 430 MHz; Wideband; 64QAM .....	27
Plot 5-19:	Conducted Spurious Emissions – 450 MHz; Narrowband; QPSK .....	28
Plot 5-20:	Conducted Spurious Emissions – 450 MHz; Narrowband; 16QAM .....	29
Plot 5-21:	Conducted Spurious Emissions – 450 MHz; Narrowband; 64QAM .....	30
Plot 5-22:	Conducted Spurious Emissions – 450 MHz; Wideband; QPSK .....	31
Plot 5-23:	Conducted Spurious Emissions – 450 MHz; Wideband; 16QAM .....	32
Plot 5-24:	Conducted Spurious Emissions – 450 MHz; Wideband; 64QAM .....	33
Plot 5-25:	Conducted Spurious Emissions – 460 MHz; Narrowband; QPSK .....	34
Plot 5-26:	Conducted Spurious Emissions – 460 MHz; Narrowband; 16QAM .....	35
Plot 5-27:	Conducted Spurious Emissions – 460 MHz; Narrowband; 64QAM .....	36
Plot 5-28:	Conducted Spurious Emissions – 460 MHz; Wideband; QPSK .....	37
Plot 5-29:	Conducted Spurious Emissions – 460 MHz; Wideband; 16QAM .....	38
Plot 5-30:	Conducted Spurious Emissions – 460 MHz; Wideband; 64QAM .....	39
Plot 5-31:	Conducted Spurious Emissions – 470 MHz; Narrowband; QPSK .....	40
Plot 5-32:	Conducted Spurious Emissions – 470 MHz; Narrowband; 16QAM .....	41
Plot 5-33:	Conducted Spurious Emissions – 470 MHz; Narrowband; 64QAM .....	42
Plot 5-34:	Conducted Spurious Emissions – 470 MHz; Wideband; QPSK .....	43
Plot 5-35:	Conducted Spurious Emissions – 470 MHz; Wideband; 16QAM .....	44
Plot 5-36:	Conducted Spurious Emissions – 470 MHz; Wideband; 64QAM .....	45
Plot 7-1:	Occupied Bandwidth – 406.1 MHz; Mask D .....	52
Plot 7-2:	Occupied Bandwidth – 418.0 MHz; Mask D .....	53
Plot 7-3:	Occupied Bandwidth – 430.0 MHz; Mask D .....	54
Plot 7-4:	Occupied Bandwidth – 450.0 MHz; Mask D .....	55
Plot 7-5:	Occupied Bandwidth – 460.0 MHz; Mask D .....	56
Plot 7-6:	Occupied Bandwidth – 470.0 MHz; Mask D .....	57
Plot 7-7:	Occupied Bandwidth – 406.1 MHz; Mask C; 25 kHz Channel Spacing .....	58
Plot 7-8:	Occupied Bandwidth – 418.0 MHz; Mask C; 25 kHz Channel Spacing .....	59
Plot 7-9:	Occupied Bandwidth – 430.0 MHz; Mask C; 25 kHz Channel Spacing .....	60
Plot 7-10:	Occupied Bandwidth – 450.0 MHz; Mask C; 25 kHz Channel Spacing .....	61
Plot 7-11:	Occupied Bandwidth – 460.0 MHz; Mask C; 25 kHz Channel Spacing .....	62
Plot 7-12:	Occupied Bandwidth – 470.0 MHz; Mask C; 25 kHz Channel Spacing .....	63

Plot 9-1:	Transient Frequency Behavior – On Time; 406.1 MHz; 12.5 kHz Channel Spacing .....	68
Plot 9-2:	Transient Frequency Behavior – On Time; 418.0 MHz; 12.5 kHz Channel Spacing .....	69
Plot 9-3:	Transient Frequency Behavior – On Time; 430.0 MHz; 12.5 kHz Channel Spacing .....	70
Plot 9-4:	Transient Frequency Behavior – On Time; 450.0 MHz; 12.5 kHz Channel Spacing .....	71
Plot 9-5:	Transient Frequency Behavior – On Time; 460.0 MHz; 12.5 kHz Channel Spacing .....	72
Plot 9-6:	Transient Frequency Behavior – On Time; 470.0 MHz; 12.5 kHz Channel Spacing .....	73
Plot 9-7:	Transient Frequency Behavior – Off Time; 406.1 MHz; 12.5 kHz Channel Spacing .....	74
Plot 9-8:	Transient Frequency Behavior – Off Time; 418.0 MHz; 12.5 kHz Channel Spacing .....	75
Plot 9-9:	Transient Frequency Behavior – Off Time; 430.0 MHz; 12.5 kHz Channel Spacing .....	76
Plot 9-10:	Transient Frequency Behavior – Off Time; 450.0 MHz; 12.5 kHz Channel Spacing .....	77
Plot 9-11:	Transient Frequency Behavior – Off Time; 460.0 MHz; 12.5 kHz Channel Spacing .....	78
Plot 9-12:	Transient Frequency Behavior – Off Time; 470.0 MHz; 12.5 kHz Channel Spacing .....	79
Plot 9-13:	Transient Frequency Behavior – On Time; 406.1 MHz; 25 kHz Channel Spacing .....	80
Plot 9-14:	Transient Frequency Behavior – On Time; 418.0 MHz; 25 kHz Channel Spacing .....	81
Plot 9-15:	Transient Frequency Behavior – On Time; 430.0 MHz; 25 kHz Channel Spacing .....	82
Plot 9-16:	Transient Frequency Behavior – On Time; 450.0 MHz; 25 kHz Channel Spacing .....	83
Plot 9-17:	Transient Frequency Behavior – On Time; 460.0 MHz; 25 kHz Channel Spacing .....	84
Plot 9-18:	Transient Frequency Behavior – On Time; 470.0 MHz; 25 kHz Channel Spacing .....	85
Plot 9-19:	Transient Frequency Behavior – Off Time; 406.1 MHz; 25 kHz Channel Spacing .....	86
Plot 9-20:	Transient Frequency Behavior – Off Time; 418.0 MHz; 25 kHz Channel Spacing .....	87
Plot 9-21:	Transient Frequency Behavior – Off Time; 430.0 MHz; 25 kHz Channel Spacing .....	88
Plot 9-22:	Transient Frequency Behavior – Off Time; 450.0 MHz; 25 kHz Channel Spacing .....	89
Plot 9-23:	Transient Frequency Behavior – Off Time; 460.0 MHz; 25 kHz Channel Spacing .....	90
Plot 9-24:	Transient Frequency Behavior – Off Time; 470.0 MHz; 25 kHz Channel Spacing .....	91
Plot 11-1:	Occupied Bandwidth 406.1 MHz; 12.5 kHz Channel Spacing .....	94
Plot 11-2:	Occupied Bandwidth 406.1 MHz; 25 kHz Channel Spacing .....	95
Plot 11-3:	Occupied Bandwidth 418.0 MHz; 12.5 kHz Channel Spacing .....	96
Plot 11-4:	Occupied Bandwidth 418.0 MHz; 25 kHz Channel Spacing .....	97
Plot 11-5:	Occupied Bandwidth 430.0 MHz; 12.5 kHz Channel Spacing .....	98
Plot 11-6:	Occupied Bandwidth 430.0 MHz; 25 kHz Channel Spacing .....	99
Plot 11-7:	Occupied Bandwidth 450.0 MHz; 12.5 kHz Channel Spacing .....	100
Plot 11-8:	Occupied Bandwidth 450.0 MHz; 25 kHz Channel Spacing .....	101
Plot 11-9:	Occupied Bandwidth 460.0 MHz; 12.5 kHz Channel Spacing .....	102
Plot 11-10:	Occupied Bandwidth 460.0 MHz; 25 kHz Channel Spacing .....	103
Plot 11-11:	Occupied Bandwidth 470.0 MHz; 12.5 kHz Channel Spacing .....	104
Plot 11-12:	Occupied Bandwidth 470.0 MHz; 25 kHz Channel Spacing .....	105

**Table of Figures**

---



---

Figure 2-1:	Configuration of Tested System .....	7
-------------	--------------------------------------	---

**Table of Tables**

Table 2-1:	Equipment Under Test (EUT).....	7
Table 2-2:	Ports and Cabling (EUT) .....	7
Table 2-3:	Support Equipment.....	7
Table 4-1:	RF Conducted Output Power – Measured .....	8
Table 4-2:	Test Equipment Used For Testing RF Power Output - Conducted.....	8
Table 5-1:	Test Equipment Used For Testing Spurious Emissions.....	45
Table 6-1:	Field Strength of Spurious Radiation – 406.1 MHz.....	46
Table 6-2:	Field Strength of Spurious Radiation – 418 MHz.....	47
Table 6-3:	Field Strength of Spurious Radiation – 430 MHz.....	47
Table 6-4:	Field Strength of Spurious Radiation – 450 MHz.....	48
Table 6-5:	Field Strength of Spurious Radiation – 460 MHz.....	48
Table 6-6:	Field Strength of Spurious Radiation – 470 MHz.....	49
Table 6-7:	Test Equipment Used For Testing Field Strength of Spurious Radiation .....	50
Table 7-1:	Test Equipment Used For Testing Occupied Bandwidth .....	63
Table 8-1:	Temperature Frequency Stability – 418 MHz.....	64
Table 8-2:	Temperature Frequency Stability – 460 MHz.....	65
Table 8-3:	Frequency Stability/Voltage Variation – 418 MHz.....	65
Table 8-4:	Frequency Stability/Voltage Variation – 460 MHz.....	65
Table 8-5:	Test Equipment Used For Testing Frequency Stability.....	66
Table 9-1:	Test Equipment Used For Testing Transient Frequency Behavior .....	92
Table 11-1:	99% Bandwidth Test Data .....	93
Table 11-3:	Test Equipment Used For Testing Transient Frequency Behavior.....	105

**Table of Appendixes**

Appendix A:	FCC Part 1.1307, 1.1310, 2.1091, 2.1093: RF Exposure.....	107
Appendix B:	FCC Agency Authorization.....	108
Appendix C:	FCC Confidentiality Request Letter .....	109
Appendix D:	Spectrum Efficiency Attestation .....	110
Appendix E:	IC Letters.....	111
Appendix F:	IC Confidentiality Request Letter .....	112
Appendix G:	Canadian Based Representative Attestation Letter.....	113
Appendix H:	ID Label & Location.....	114
Appendix I:	Operational Description .....	115
Appendix J:	Parts List .....	116
Appendix K:	Test/Tune Procedure .....	117
Appendix L:	Schematics.....	118
Appendix M:	Block Diagram.....	119
Appendix N:	Manual .....	120
Appendix O:	Test Configuration Photographs .....	121
Appendix P:	External Photographs.....	123
Appendix Q:	Internal Photographs.....	124

**Table of Photographs**

Photograph 1:	Radiated Emissions (Spurious/Harmonics) – Front View.....	121
Photograph 2:	Radiated Emissions (Spurious/Harmonics) – Back View .....	122

## 1 Test Result Summary

Test	FCC Reference	Result
RF Power Output	2.1046(a)	Complies
Spurious Emissions at Antenna Terminals	2.1051, 90.210	Complies
Field Strength of Spurious Radiation	2.1053(a)	Complies
Occupied Bandwidth/Emission Masks	2.1049(c)(1)	Complies
Frequency Stability vs. Temperature and Voltage	2.1055, 90.213	Complies
Modulation Characteristics	2.1047(a)(b)	Not Applicable (Digital Modulation)

## 2 General Information

The following Certification Report is prepared on behalf of **4RF Limited** in accordance with the Federal Communications Commission and Industry Canada rules and regulations. The Equipment Under Test (EUT) was Model # SQ400M131, **FCC ID: UIPSQ400M131, IC: 6772A-SQ400M131**. The test results reported in this document relate only to the item that was tested.

Please note: Under current FCC rules CFR Part 90.207(i) this equipment may only be used for voice and other non-telemetry applications.

All measurements contained in this application were conducted in accordance with FCC Rules and Regulations CFR 47 Parts 2 and 101. Calibration checks are performed regularly on the instruments, and all accessories including high pass filter, coaxial attenuator, preamplifier and cables.

### 2.1 Test Facility

The open area test site and conducted measurement facility used to collect the radiated data is located on the parking lot of Rhein Tech Laboratories, Inc., 360 Herndon Parkway, Suite 1400, Herndon, Virginia, 20170.

### 2.2 Tested System Details

The EUT is a point to multipoint radio that operates in the 406.1-470 MHz bands. The rated RF output power is 37.0 dBm. The EUT is digitally modulated using either a QPSK, 16 QAM, or 64 QAM modulation type.

The test samples were received on October 3, 2013. Listed below are the identifiers and descriptions of all equipment, cables, and internal devices used with the EUT for this test, as applicable.

<b>Model # Tested</b>	SQ400M131
<b>Frequency Band</b>	406.1 - 470 MHz
<b>Modulation Type</b>	QPSK, 16 QAM, and 64 QAM
<b>Channel Step Size</b>	12.5 and 25 kHz
<b>Authorized Channel Bandwidth</b>	20 kHz
<b>Primary Power</b>	10-30 VDC
<b>Rated Transmitter Output Power</b>	37.0 dBm

**Table 2-1: Equipment Under Test (EUT)**

Part	Manufacturer	Model Number	Serial Number	RTL Bar Code
Aprisa SR+ Radio	4RF Limited	SQ400M131	N/A	21104

**Table 2-2: Ports and Cabling (EUT)**

Port	Cable Type	Quantity	Length (meter)	Shield
AC Power	N/A	1m	N/A	No
TX/Ant.	N/A	1	N/A	N/A
Ethernet	RJ-45	4	4.5	No
Alarm	RJ-45	1	2	No
Management	USB to A-Micro B with two ferrites	1	1	No
Aux.	N/A	4	1.5	No
RX	N/A	1	N/A	No

**Table 2-3: Support Equipment**

Part	Manufacturer	Model	PN/SN	ID	RTL Bar Code
Laptop Computer	Sony	Vaio	N/A	N/A	N/A

**Figure 2-1: Configuration of Tested System**

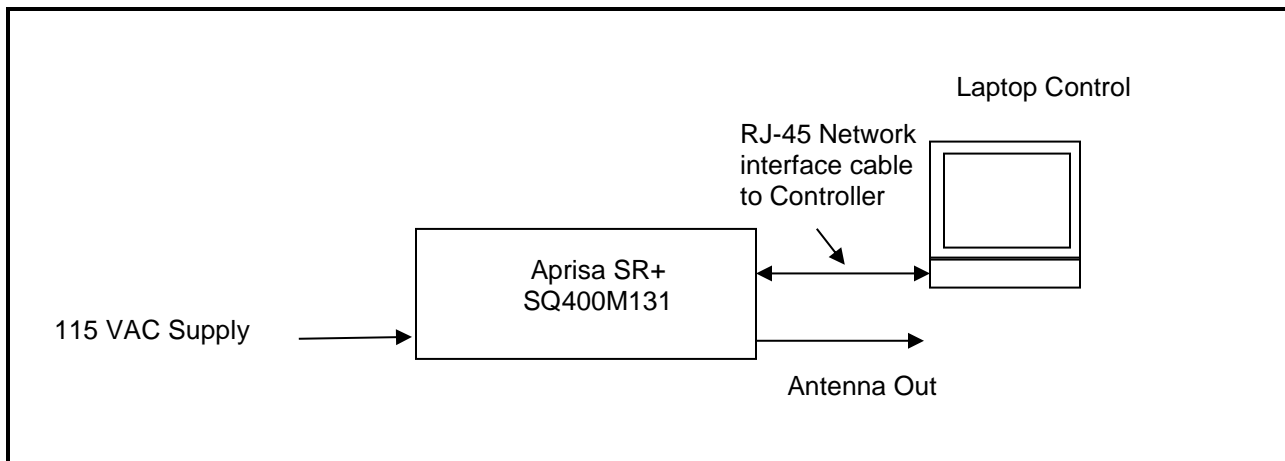

### 3 FCC Part 2.1033(c)(8) Voltages and Currents Through The Final Amplifying Stage

Final PA Voltage: 13 VDC      Final PA Current 0.7 A @ 5 W

### 4 FCC Part 2.1046(a): RF Power Output: Conducted, Part 90.541(b)/90.542(a)(6); IC RSS-119 4.1

#### 4.1 Test Procedure

ANSI/TIA/EIA-603-2004, section 2.2.1

The EUT was connected to a coaxial attenuator having a 50 Ω load impedance.

Manufacturer's rated power: 0.01 - 5 W.

#### 4.2 Test Data

**Table 4-1: RF Conducted Output Power – Measured**

Frequency (MHz)	Power (dBm)	Power (W)
406.1	37.1	5.1
418	37.1	5.1
430	37.3	5.4
450	37.1	5.1
460	37.2	5.3
470	37.0	5.0

**Table 4-2: Test Equipment Used For Testing RF Power Output - Conducted**

RTL Asset #	Manufacturer	Model	Part Type	Serial Number	Calibration Due Date
901583	Agilent Technologies	N9010A	EXA Signal Analyzer (10 Hz - 26.5 GHz)	MY51250846	4/16/14
901537	Aeroflex	48-40-34	40 dB Attenuator	CB6628	12/14/13

#### Test Personnel:

Daniel Baltzell  
 EMC Test Engineer



Signature

October 4, 2013  
 Date of Test



## 5 FCC Part 2.1051, 90.210: Conducted Spurious Emissions

### 5.1 Test Procedure

ANSI/TIA/EIA-603-2004, Section 2.2.13

The transmitter is terminated with a 50  $\Omega$  load and interfaced with a spectrum analyzer.

Device with digital modulation: Modulated to its maximum extent using a pseudo-random data sequence.

### 5.2 Test Data

Frequency range of measurement per Part 2.1057: 9 kHz to 10 x Fc

Limits:

Narrowband: (50 + 10 LOG P(W))

Wideband: (43+ 10 LOG P(W))

The following channels (in MHz) were investigated:

MHz
406.1
418.0
430.0
450.0
460.0
470.0

Both high and low power settings were checked; high power was found to be worst case and is presented. All modes were investigated and those within 20 dB of the limits are presented. Only 406.1 MHz had amplitudes within 20 dB of the limit and are shown as representative data.

**Plot 5-1: Conducted Spurious Emissions – 406.1 MHz; Narrowband; QPSK**

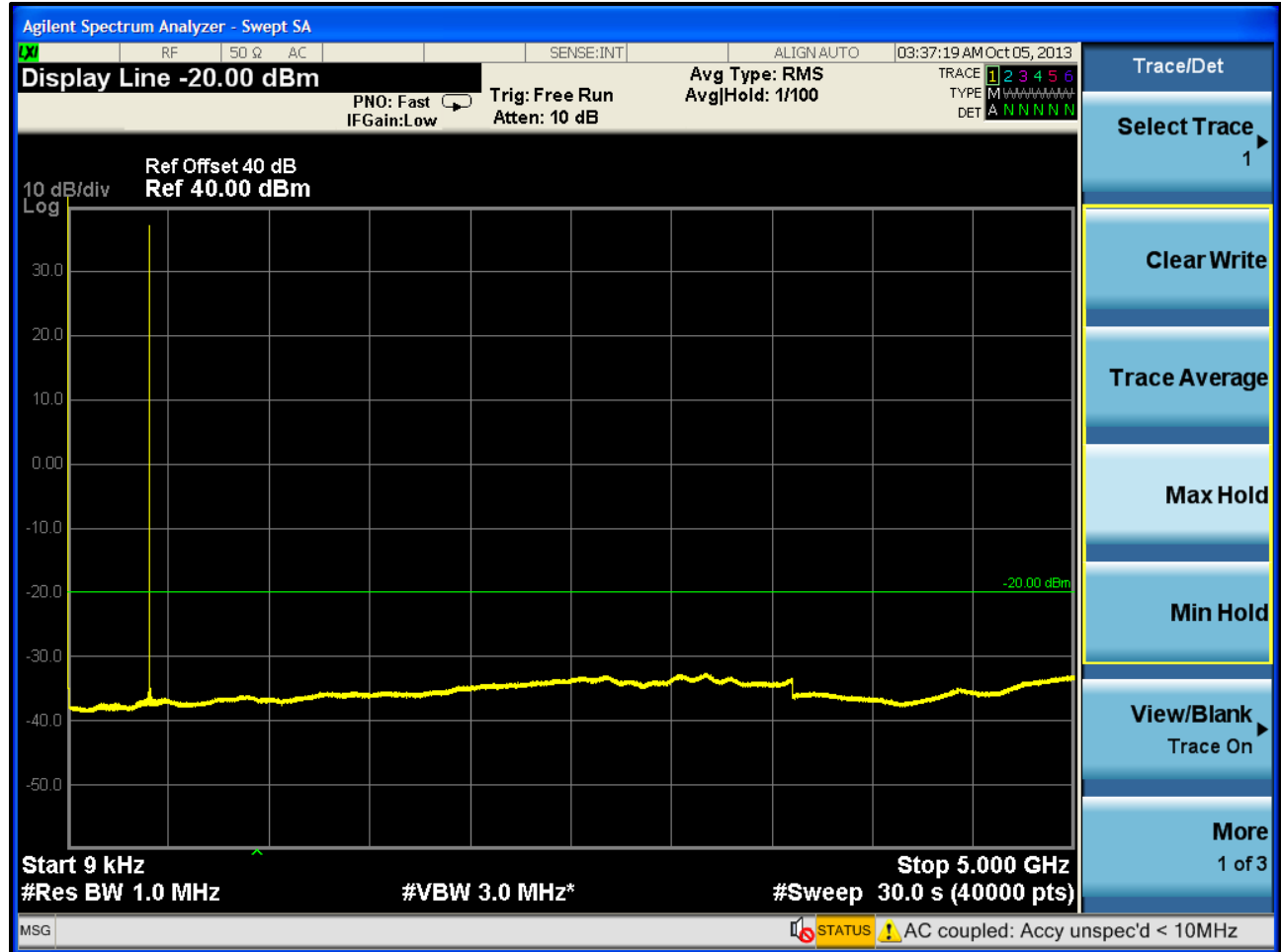

**Plot 5-2: Conducted Spurious Emissions – 406.1 MHz; Narrowband; 16QAM**

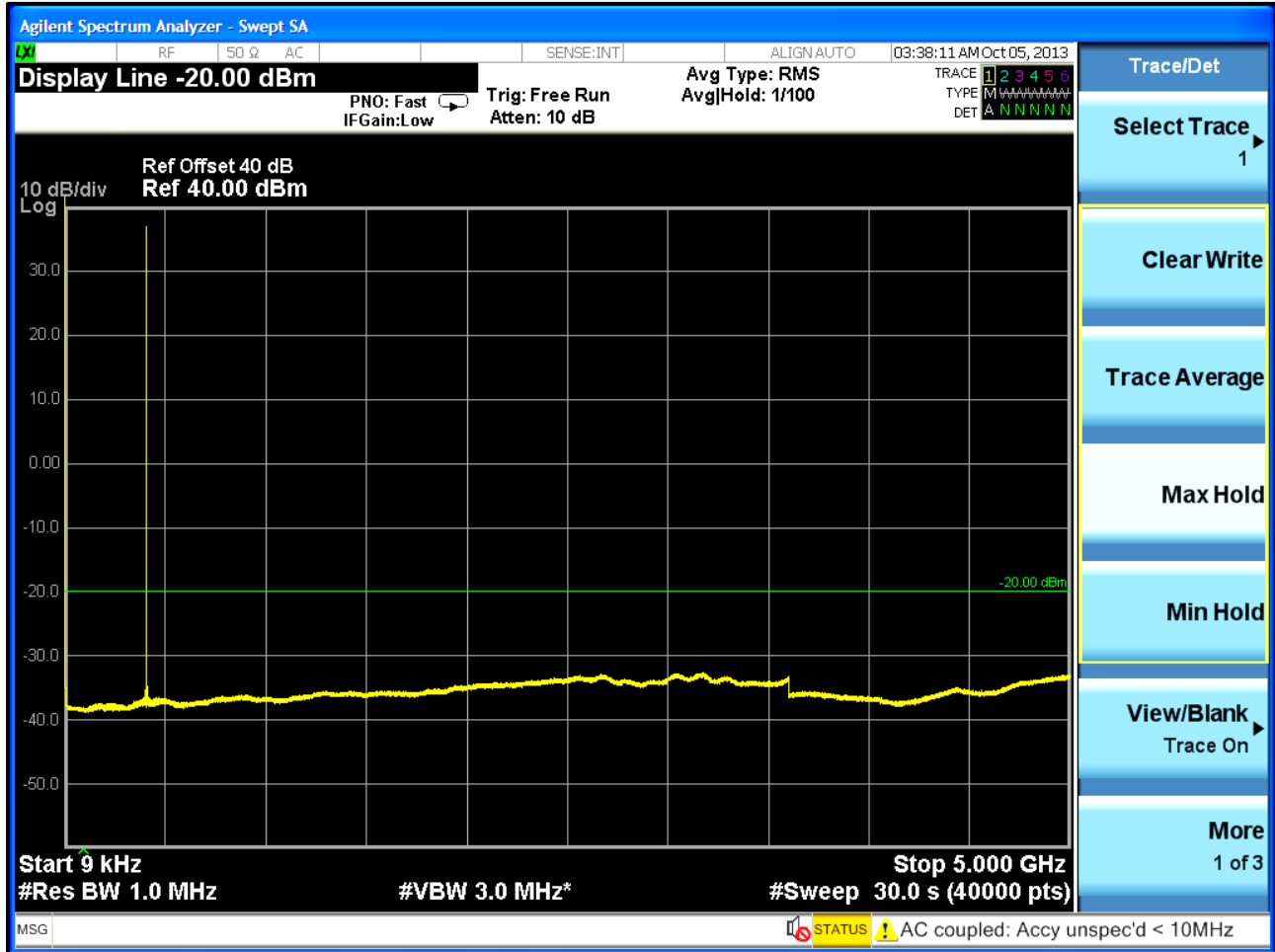

**Plot 5-3: Conducted Spurious Emissions – 406.1 MHz; Narrowband; 64QAM**

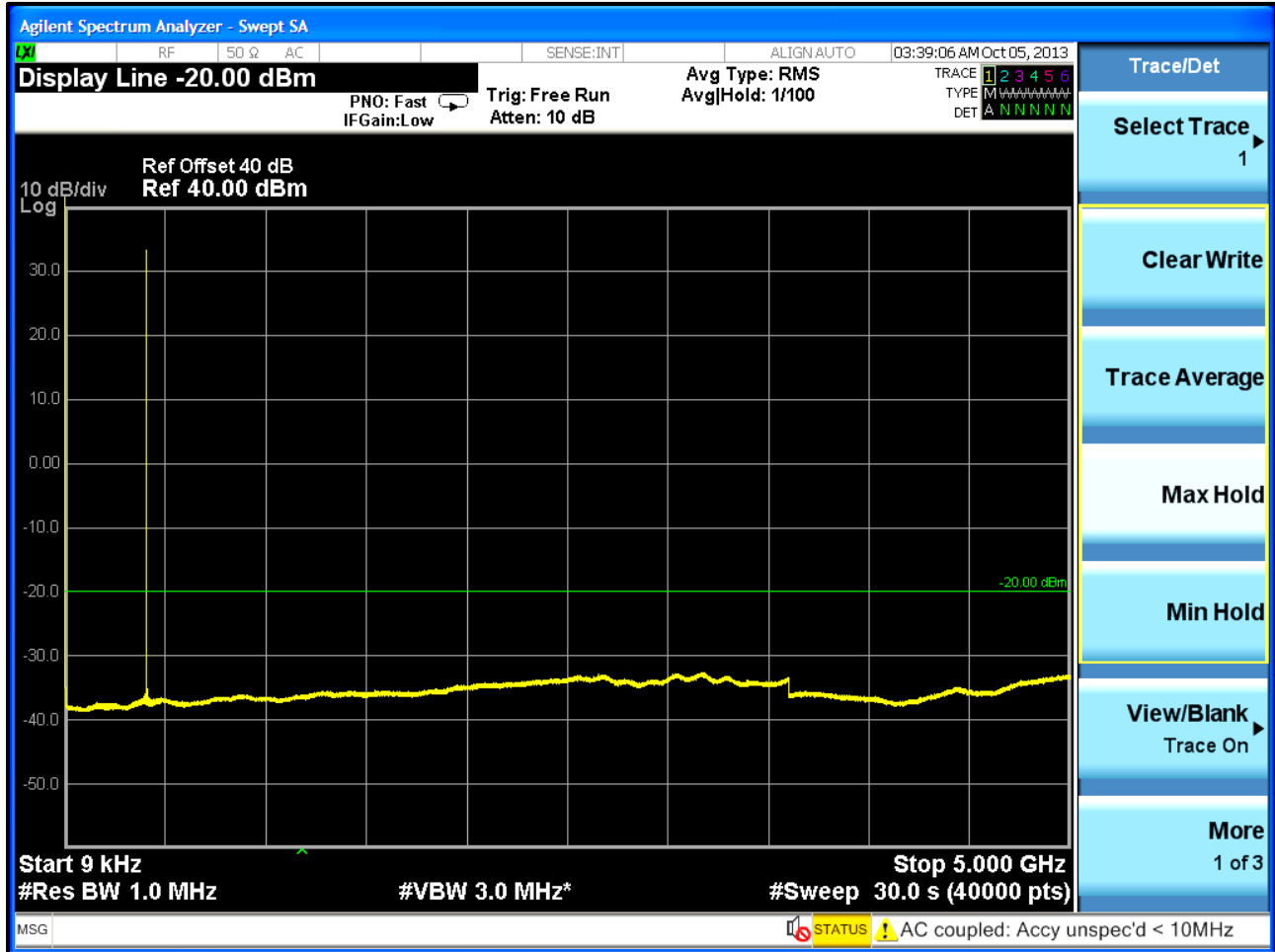

**Plot 5-4: Conducted Spurious Emissions – 406.1 MHz; Wideband; QPSK**

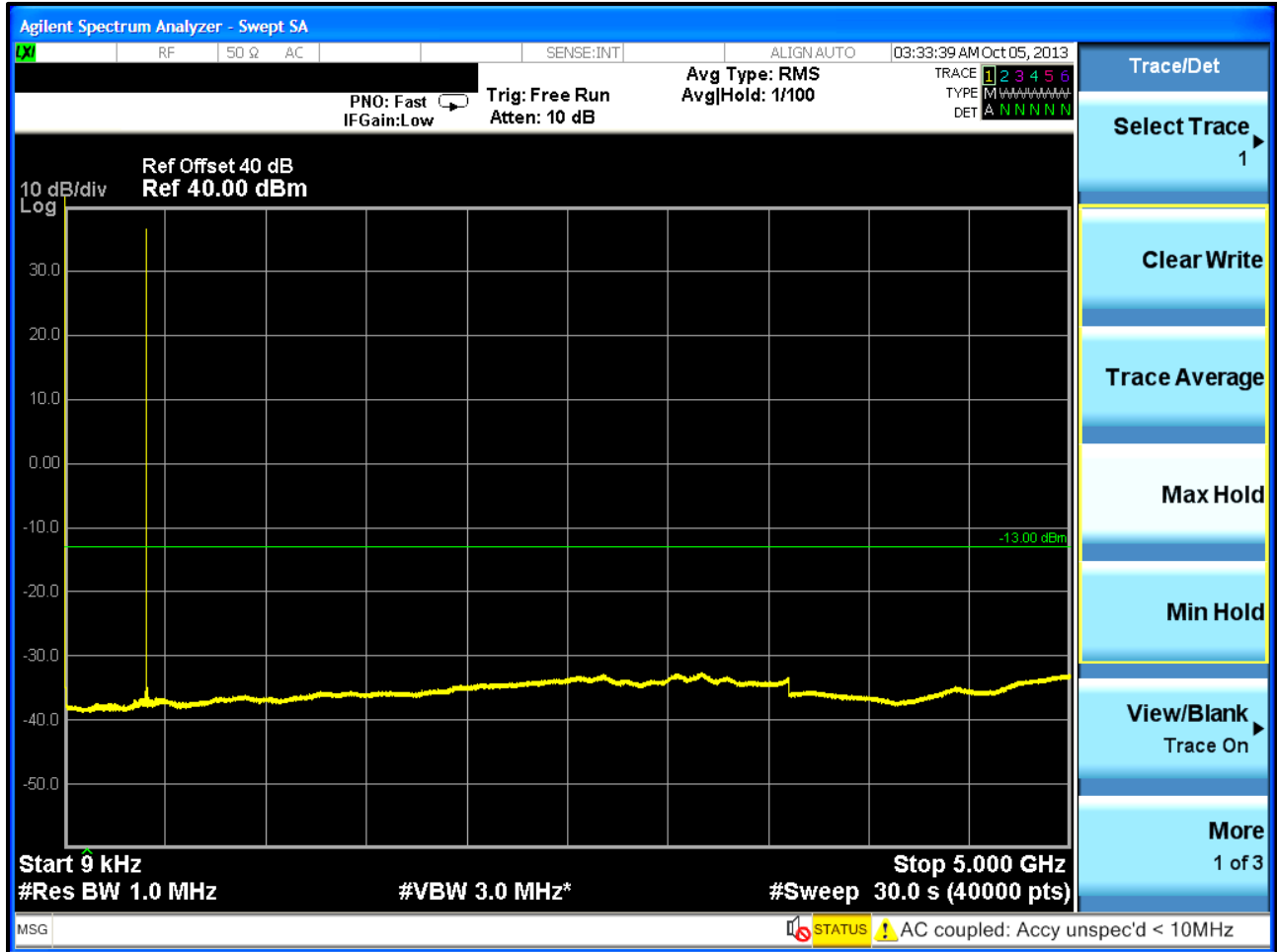

**Plot 5-5: Conducted Spurious Emissions – 406.1 MHz; Wideband; 16QAM**

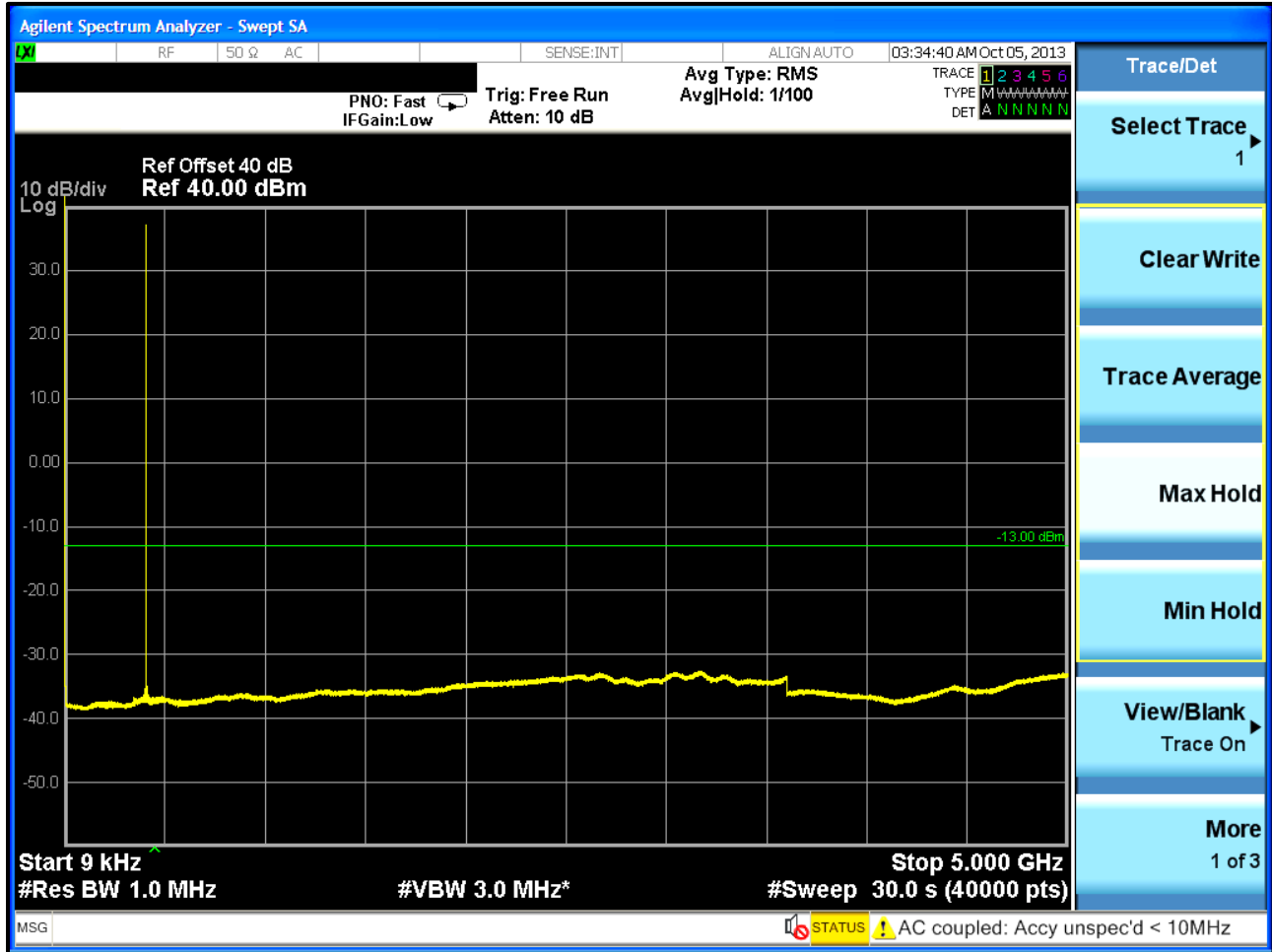

**Plot 5-6: Conducted Spurious Emissions – 406.1 MHz; Wideband; 64QAM**

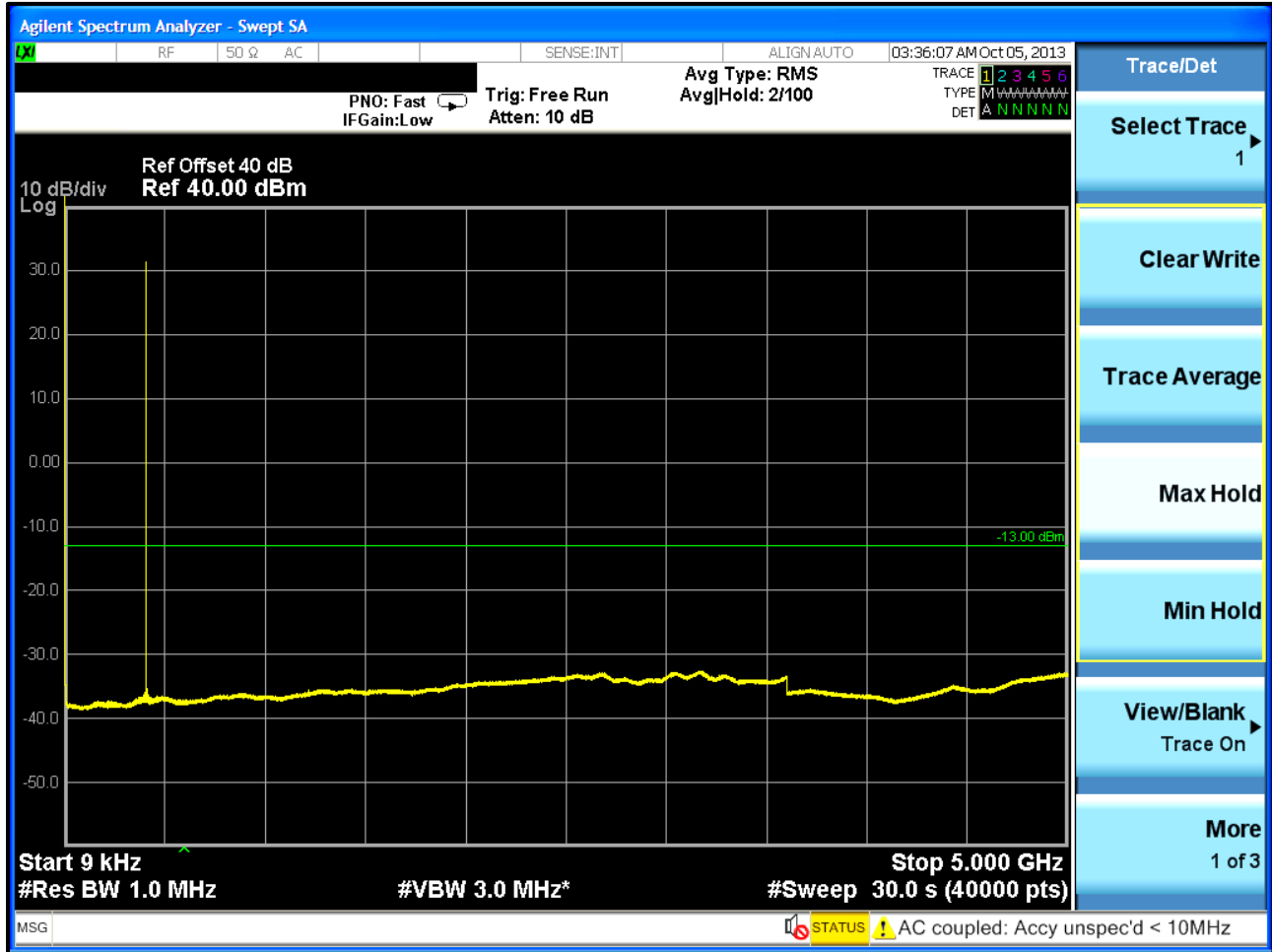

**Plot 5-7: Conducted Spurious Emissions – 418 MHz; Narrowband; QPSK**

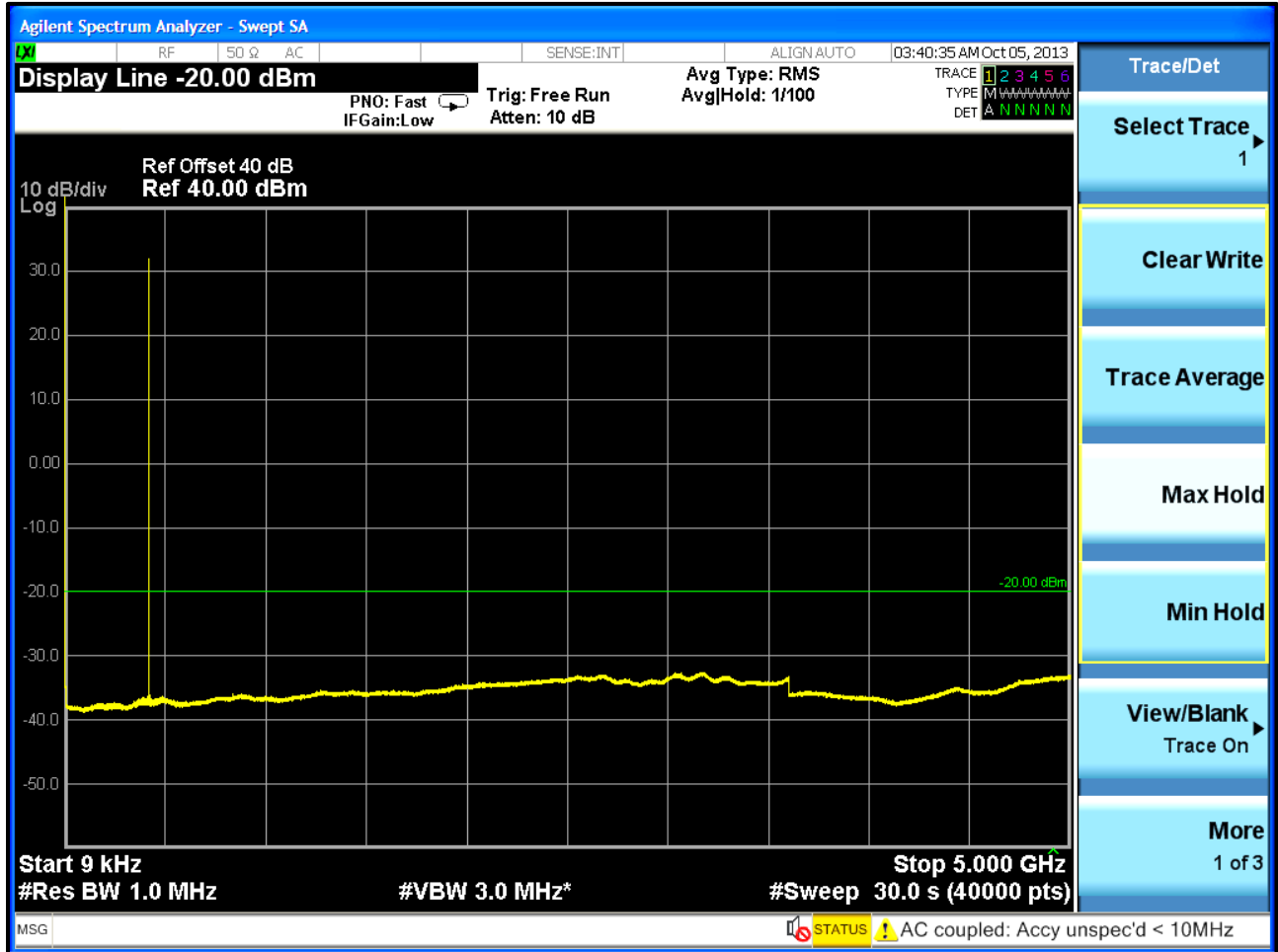



**Plot 5-8: Conducted Spurious Emissions – 418 MHz; Narrowband; 16QAM**

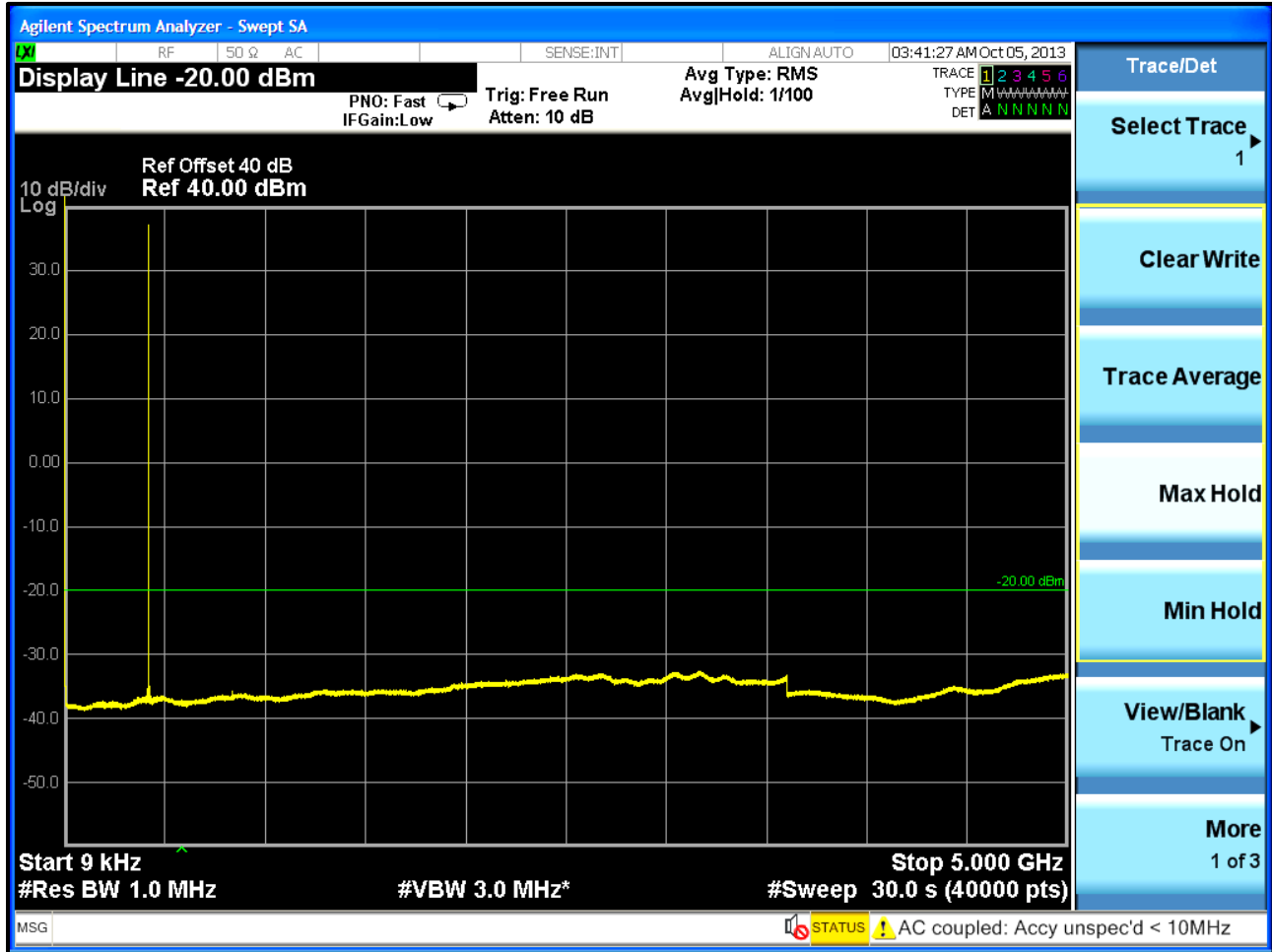

**Plot 5-9: Conducted Spurious Emissions – 418 MHz; Narrowband; 64QAM**

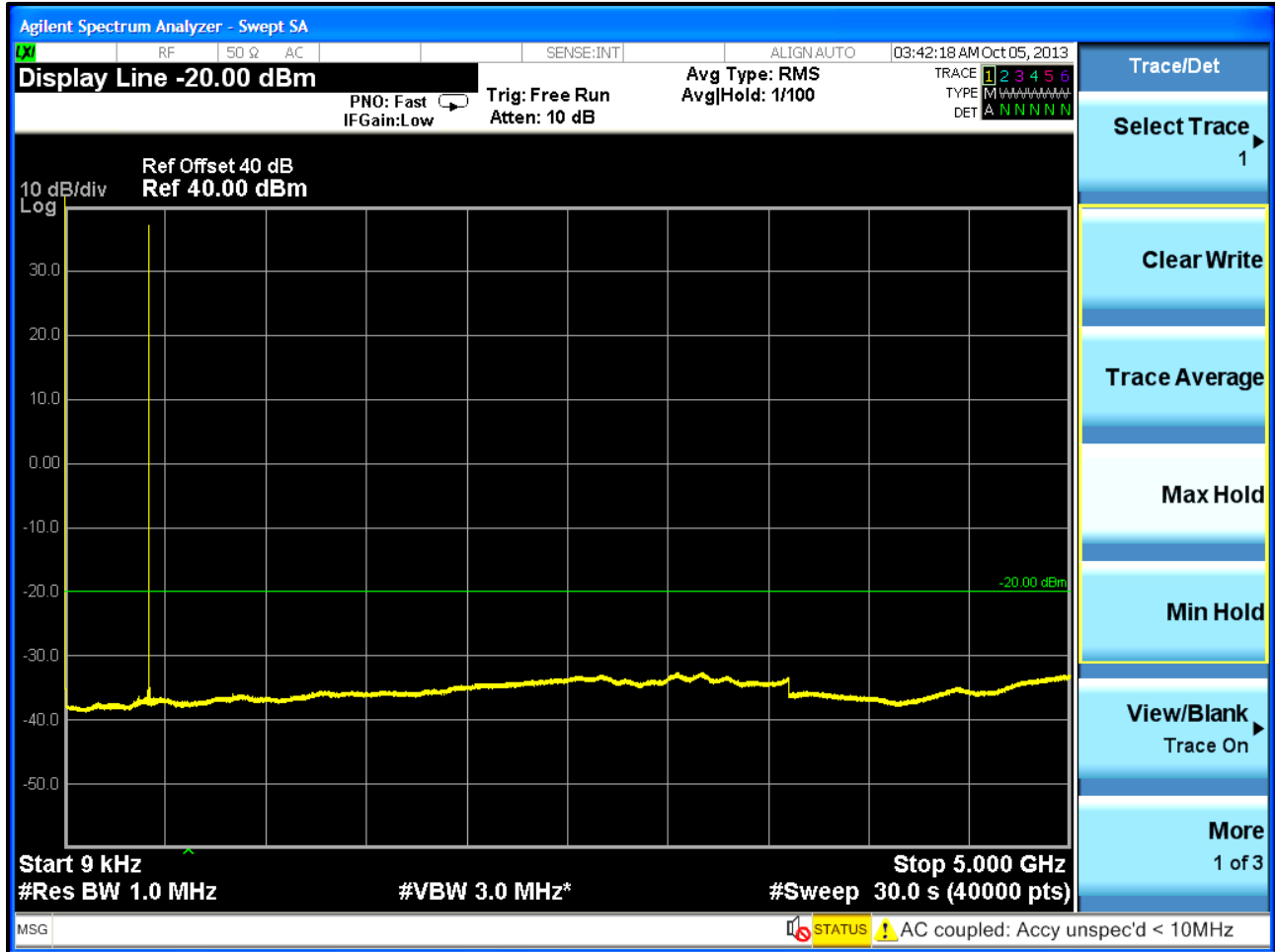

**Plot 5-10: Conducted Spurious Emissions – 418 MHz; Wideband; QPSK**



**Plot 5-11: Conducted Spurious Emissions – 418 MHz; Wideband; 16QAM**

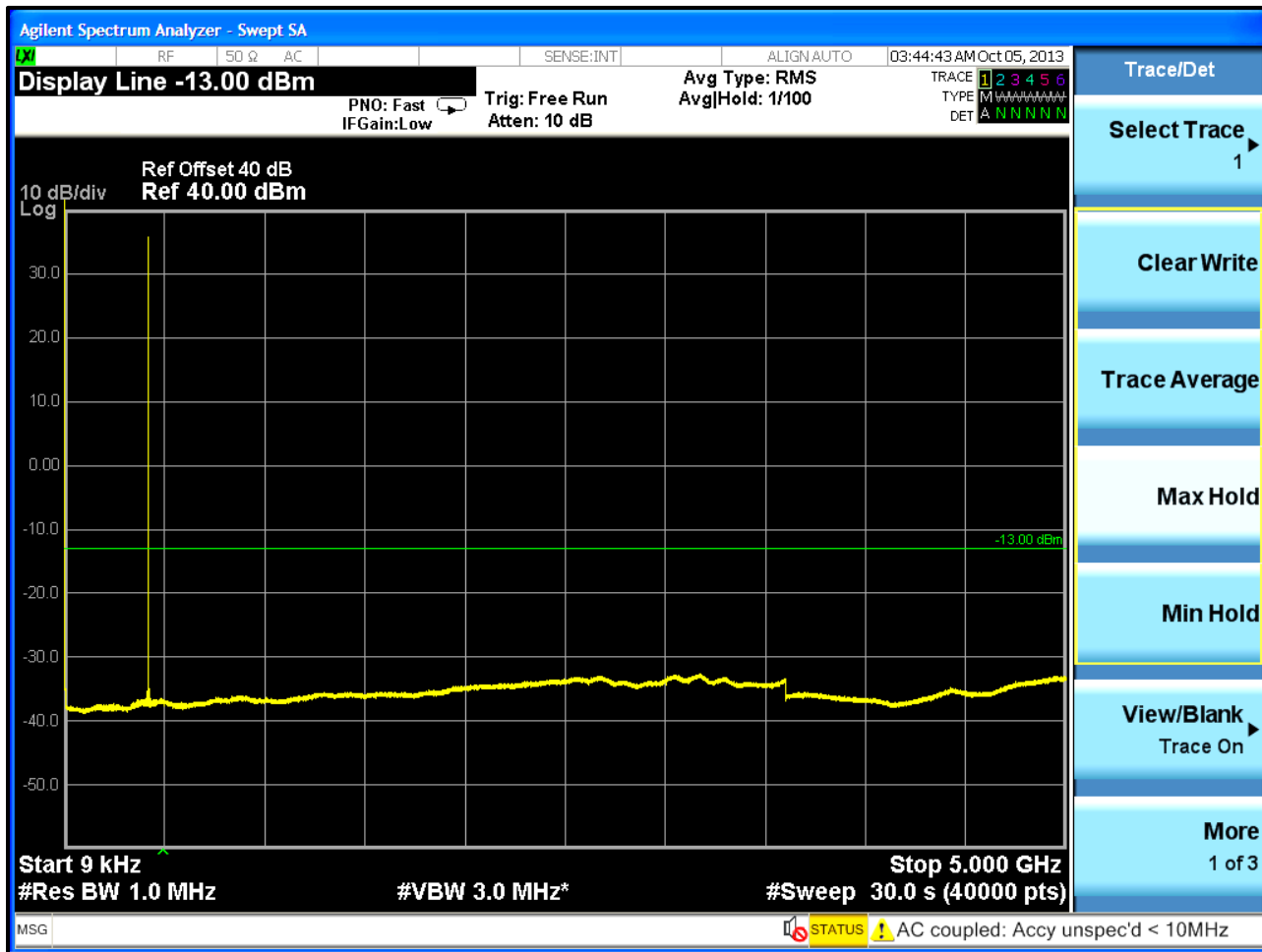

**Plot 5-12: Conducted Spurious Emissions – 418 MHz; Wideband; 64QAM**

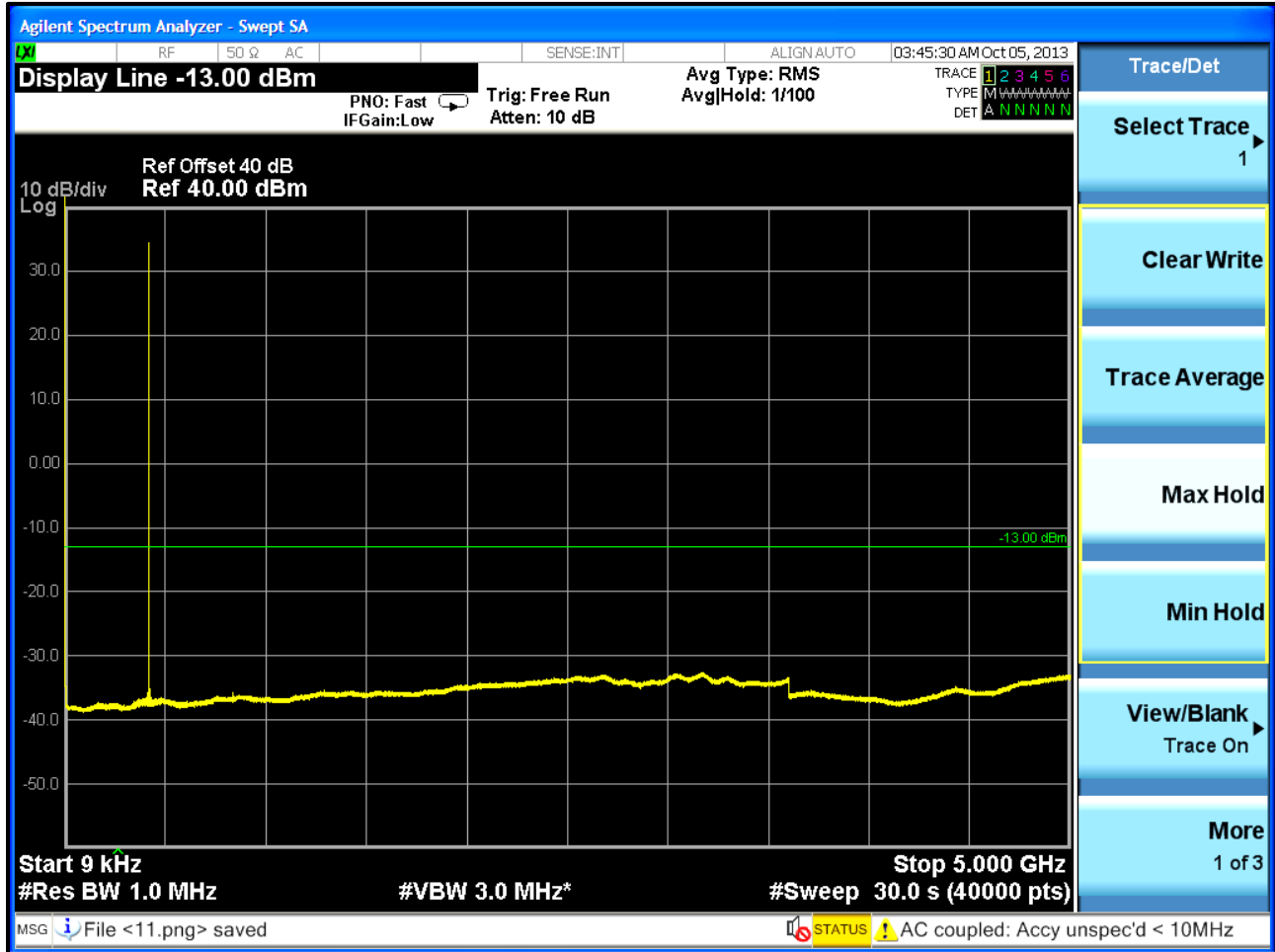

**Plot 5-13: Conducted Spurious Emissions – 430 MHz; Narrowband; QPSK**

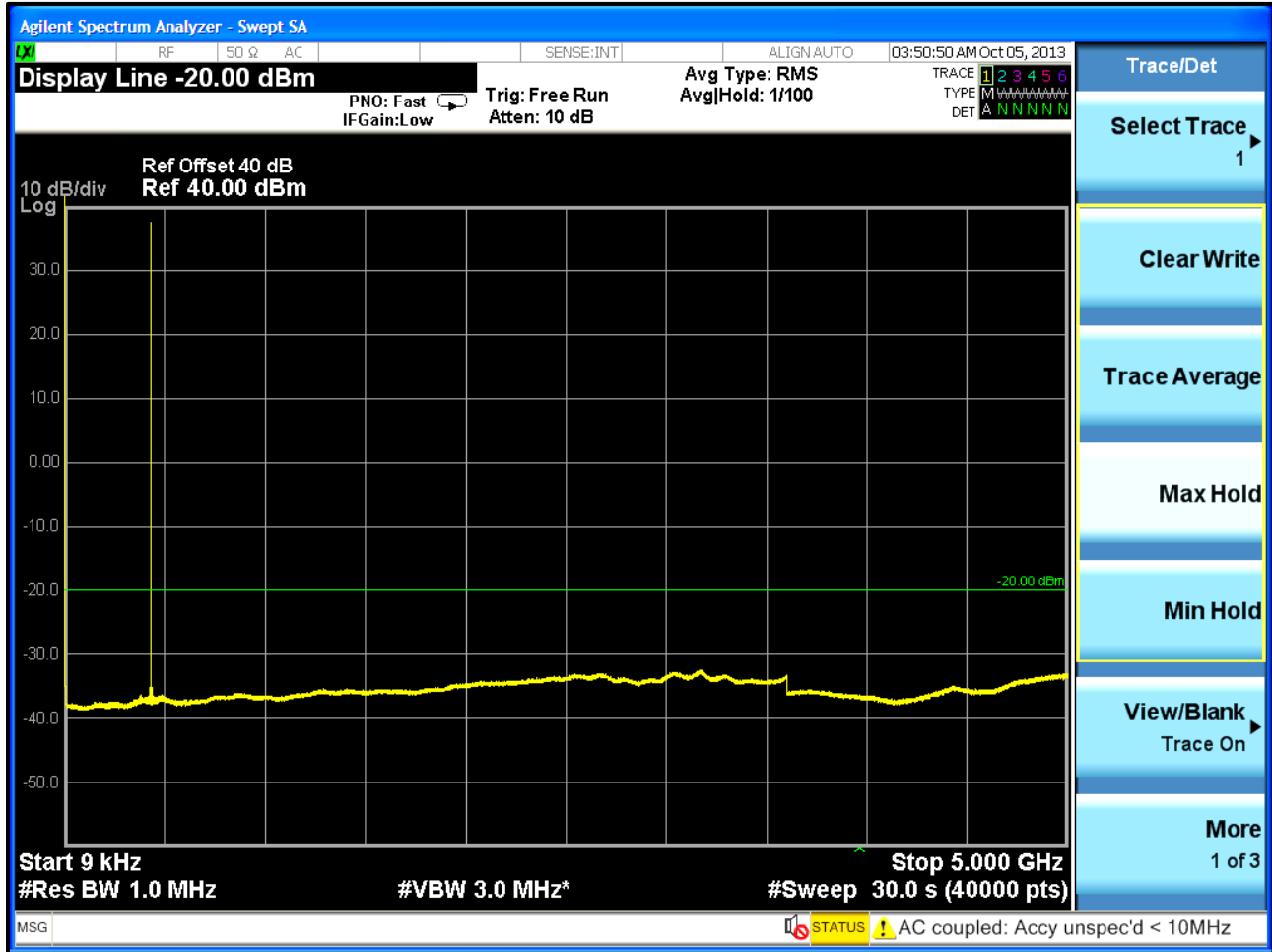

**Plot 5-14: Conducted Spurious Emissions – 430 MHz; Narrowband; 16QAM**



**Plot 5-15: Conducted Spurious Emissions – 430 MHz; Narrowband; 64QAM**

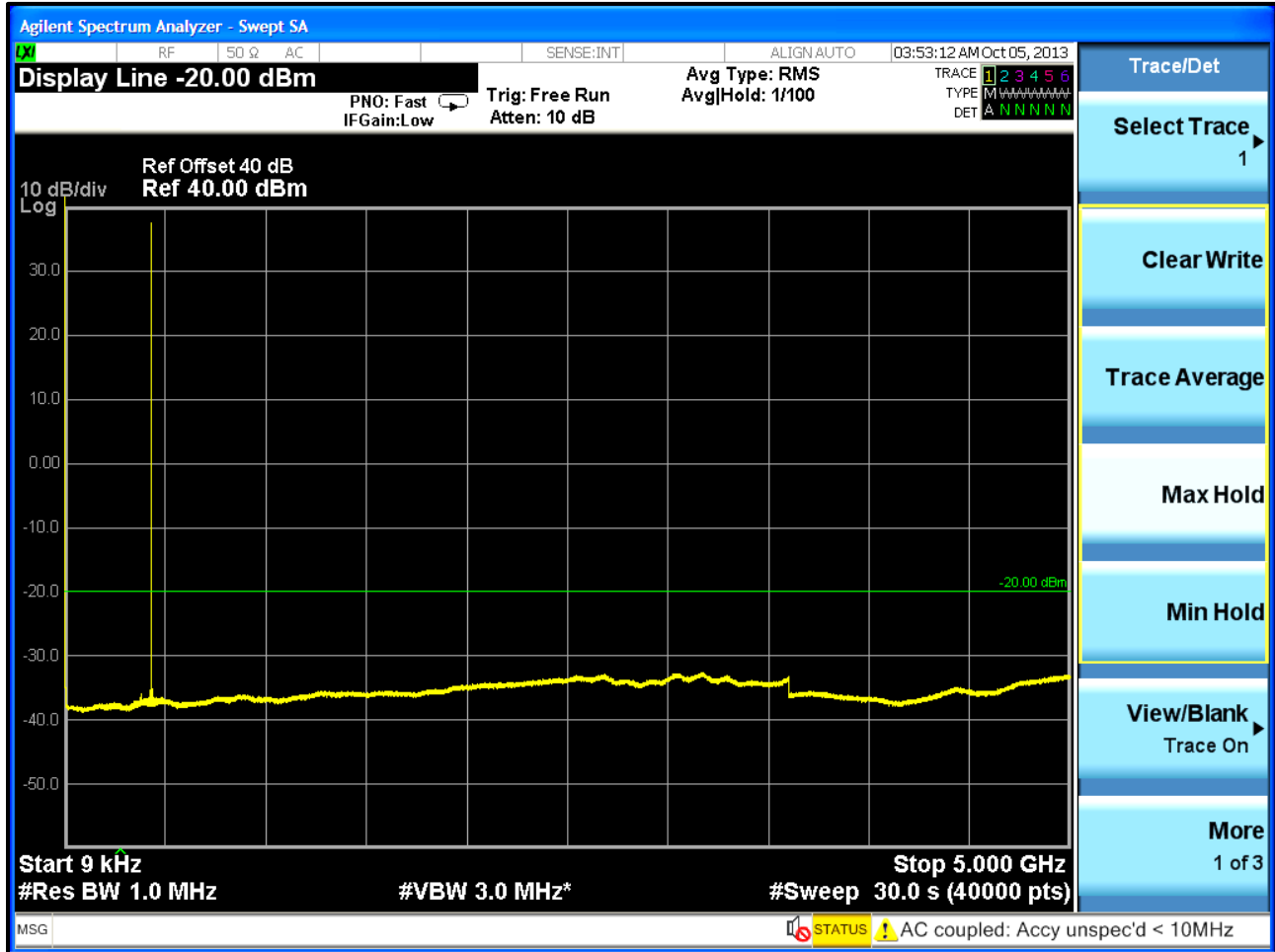



**Plot 5-16: Conducted Spurious Emissions – 430 MHz; Wideband; QPSK**

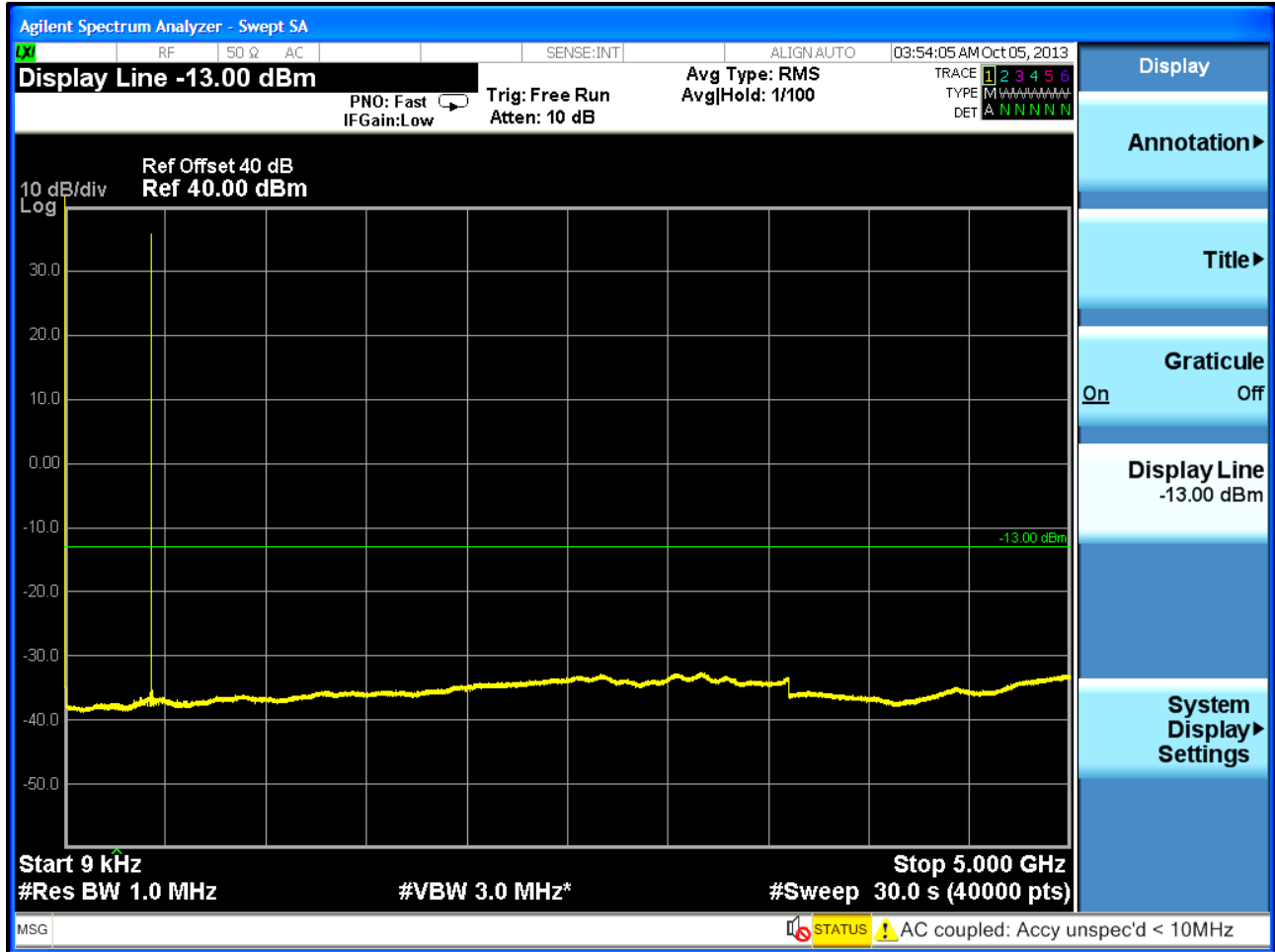

**Plot 5-17: Conducted Spurious Emissions – 430 MHz; Wideband; 16QAM**

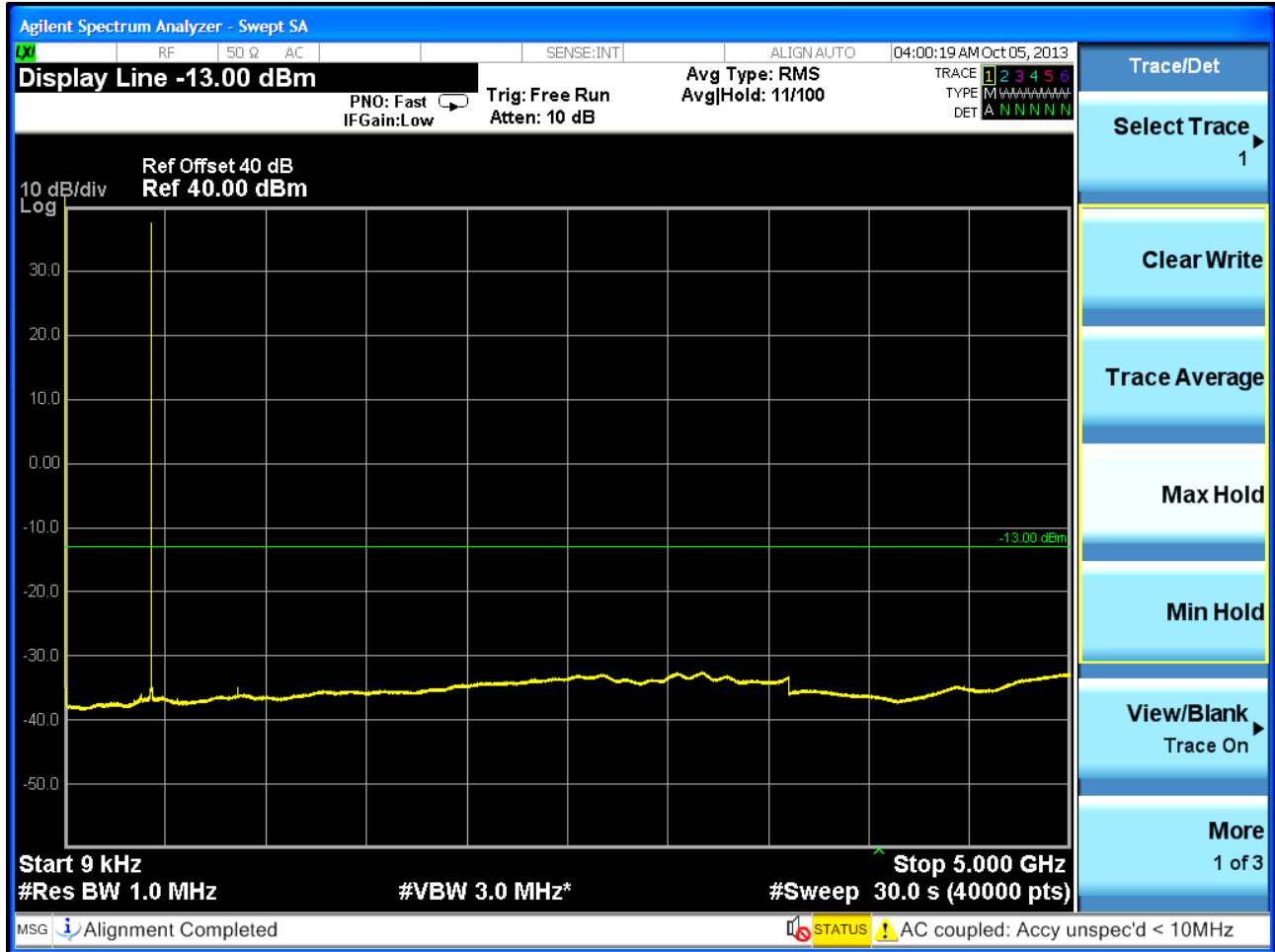

**Plot 5-18: Conducted Spurious Emissions – 430 MHz; Wideband; 64QAM**

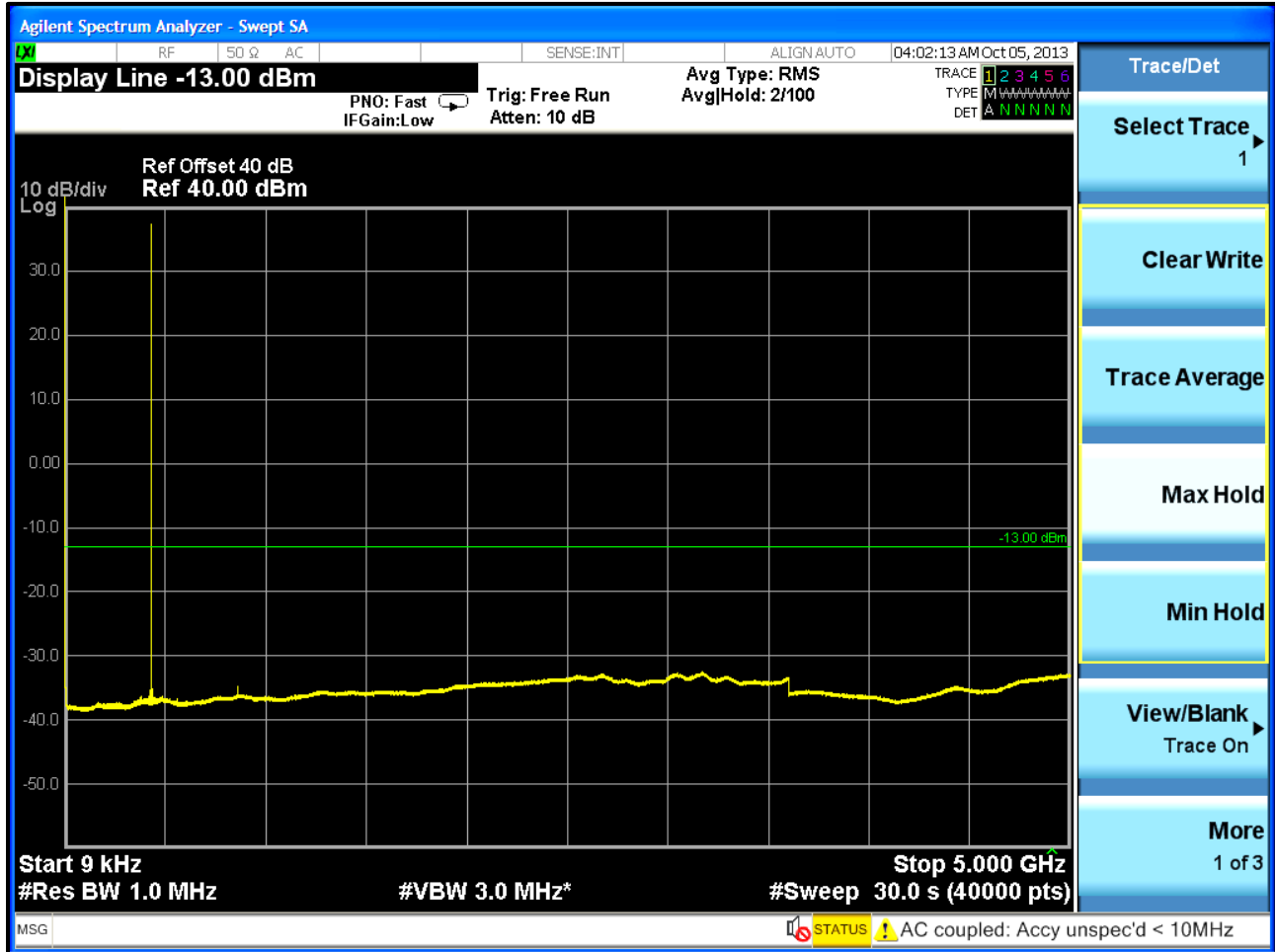

**Plot 5-19: Conducted Spurious Emissions – 450 MHz; Narrowband; QPSK**

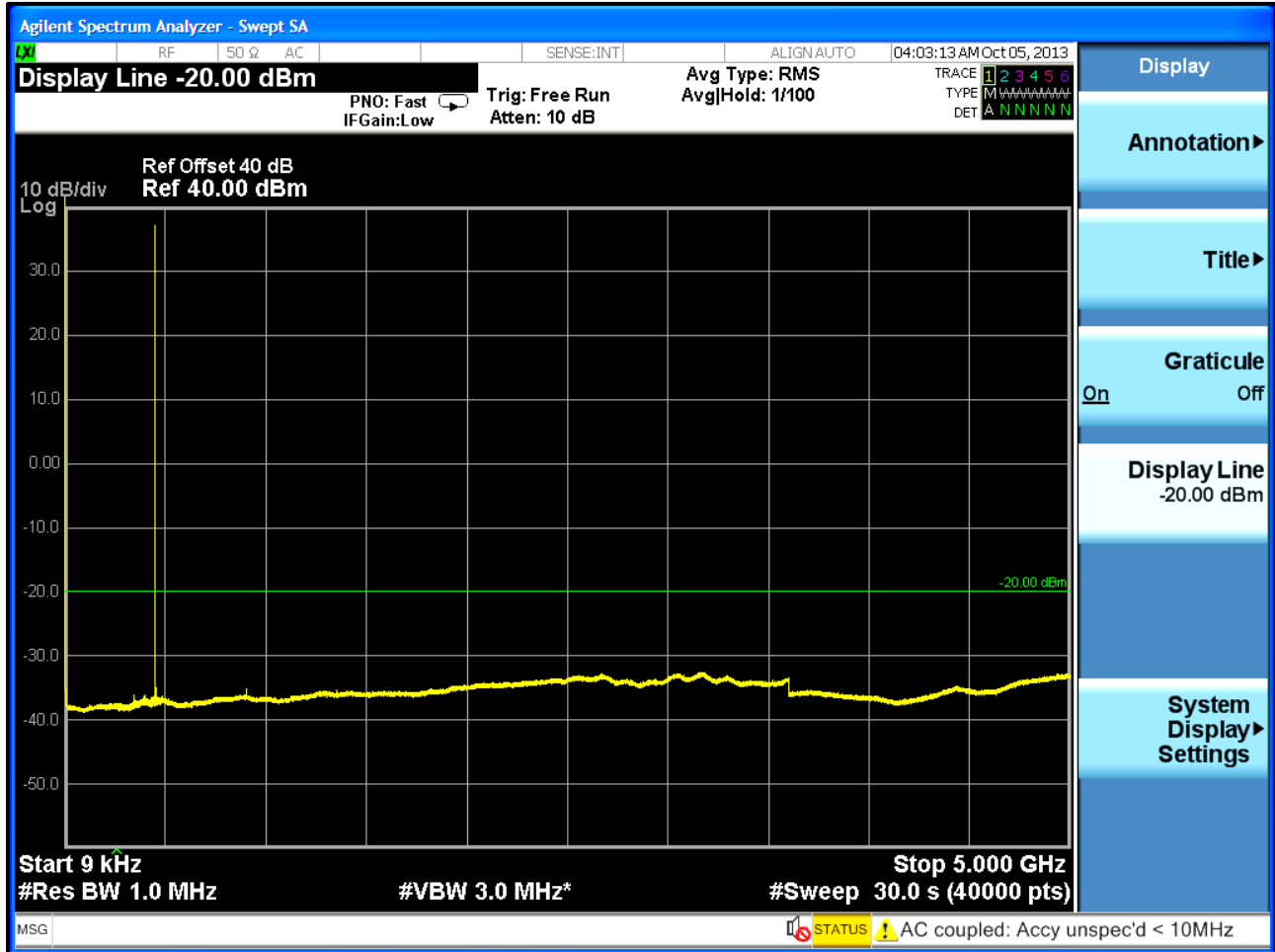

**Plot 5-20: Conducted Spurious Emissions – 450 MHz; Narrowband; 16QAM**

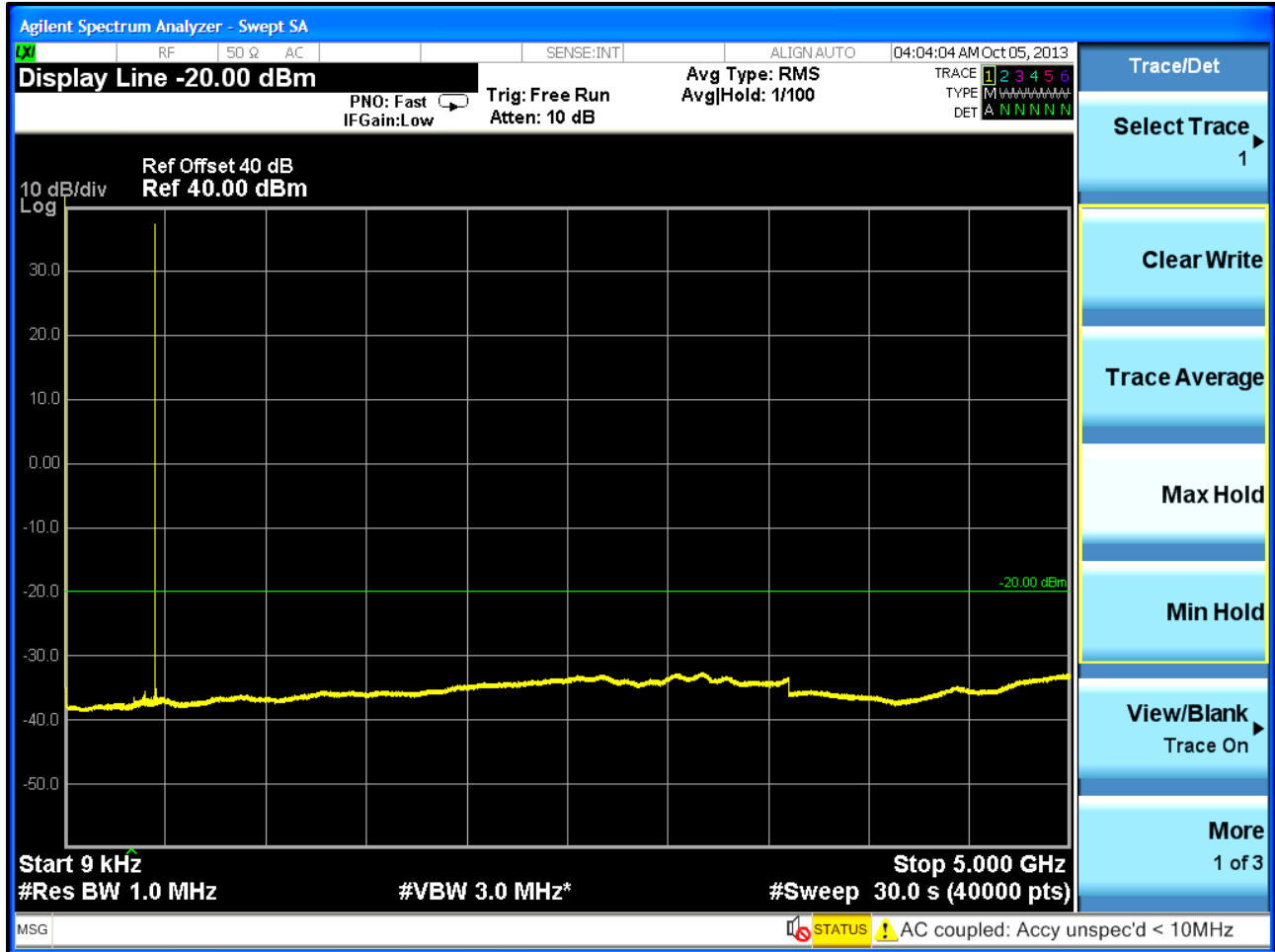

**Plot 5-21: Conducted Spurious Emissions – 450 MHz; Narrowband; 64QAM**

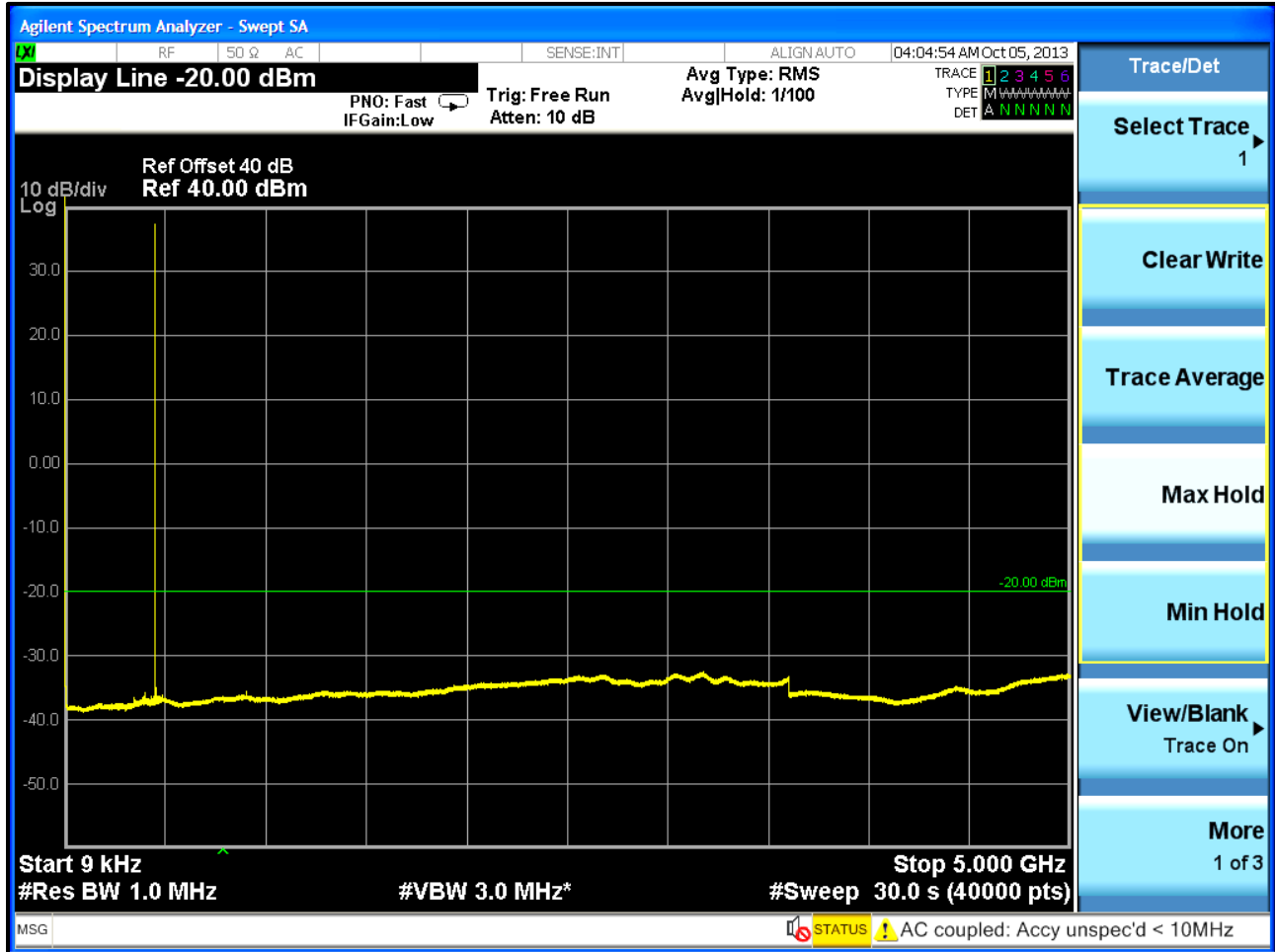

**Plot 5-22: Conducted Spurious Emissions – 450 MHz; Wideband; QPSK**

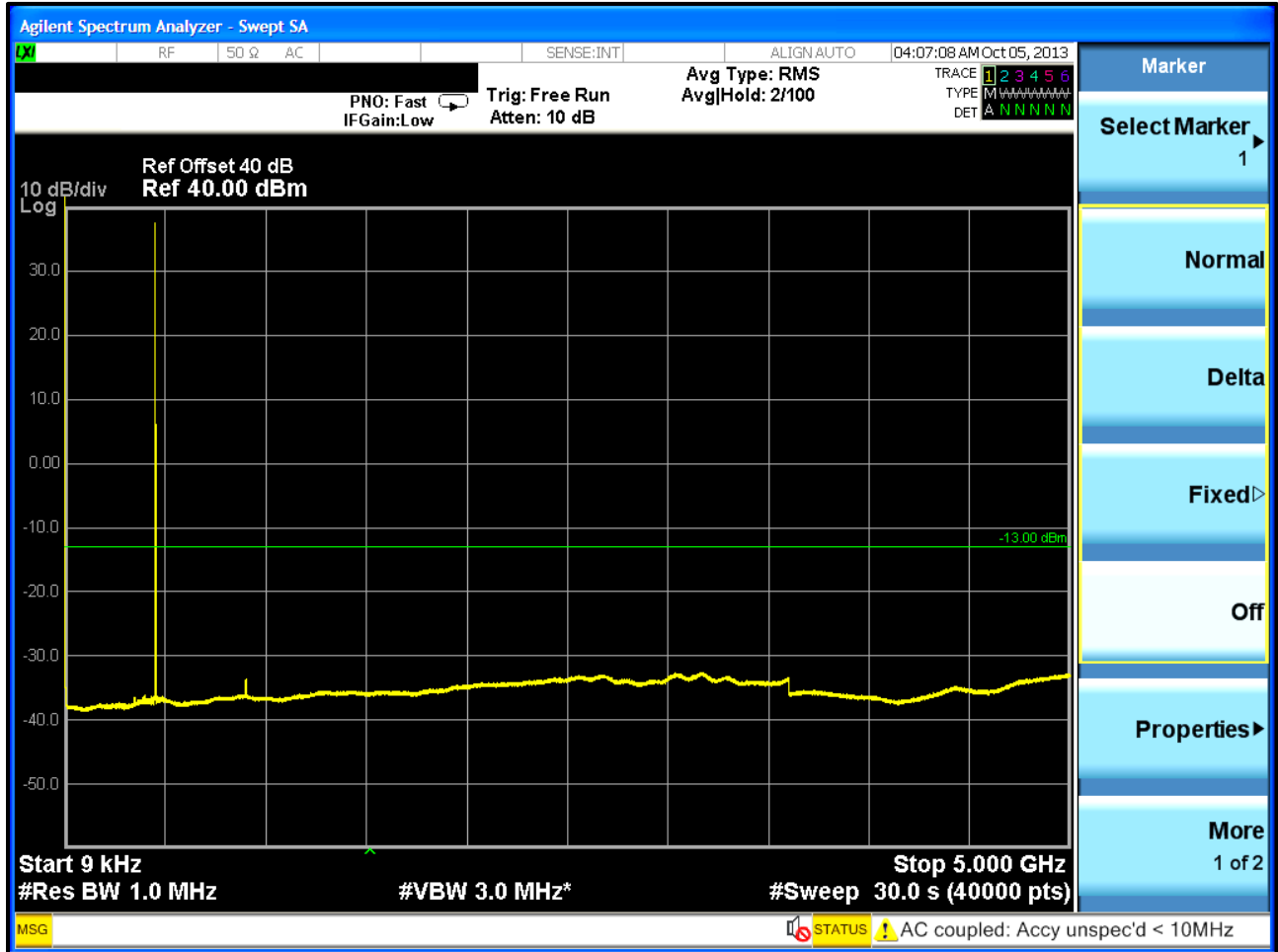

**Plot 5-23: Conducted Spurious Emissions – 450 MHz; Wideband; 16QAM**





**Plot 5-24: Conducted Spurious Emissions – 450 MHz; Wideband; 64QAM**



**Plot 5-25: Conducted Spurious Emissions – 460 MHz; Narrowband; QPSK**

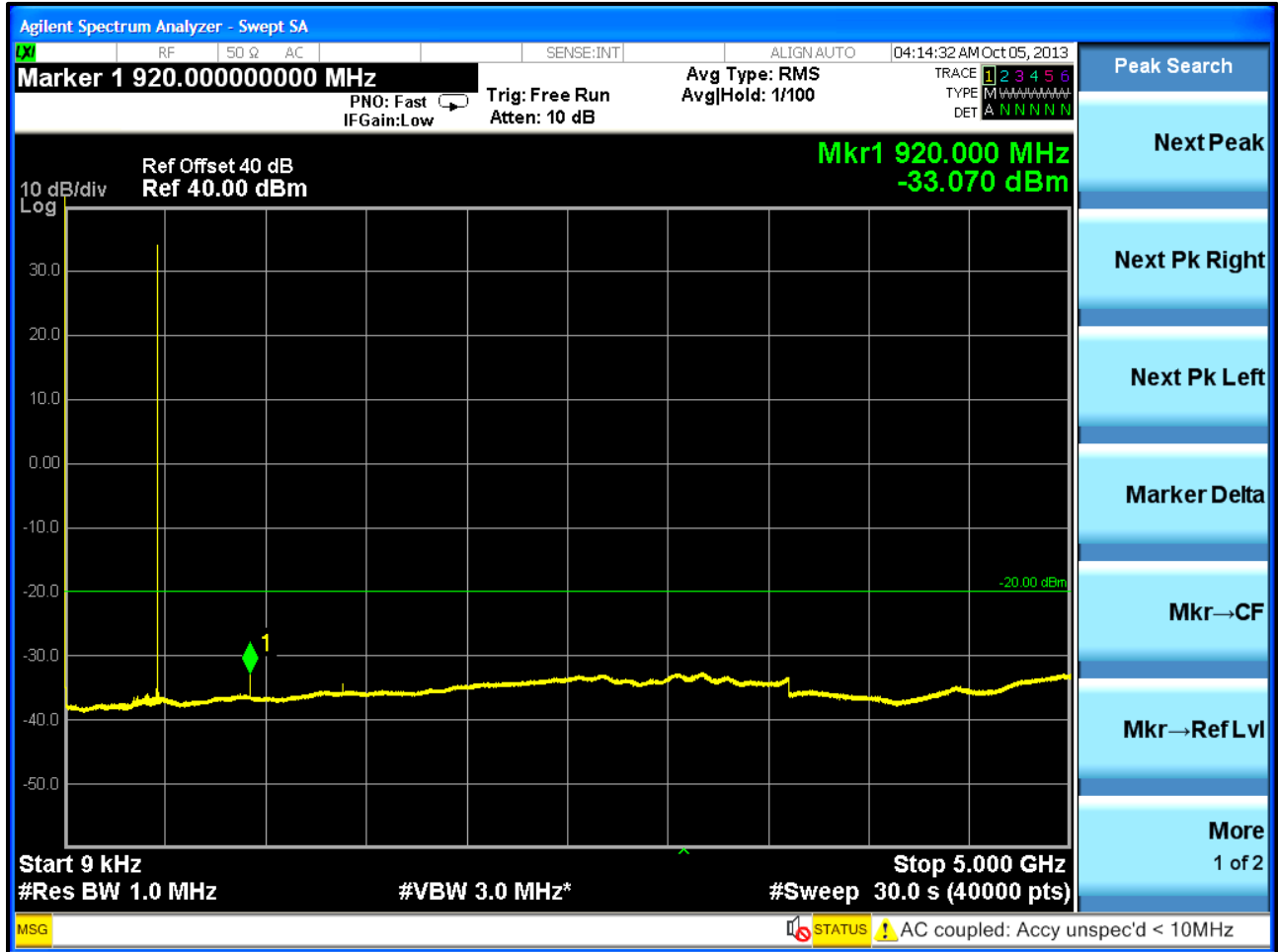

**Plot 5-26: Conducted Spurious Emissions – 460 MHz; Narrowband; 16QAM**

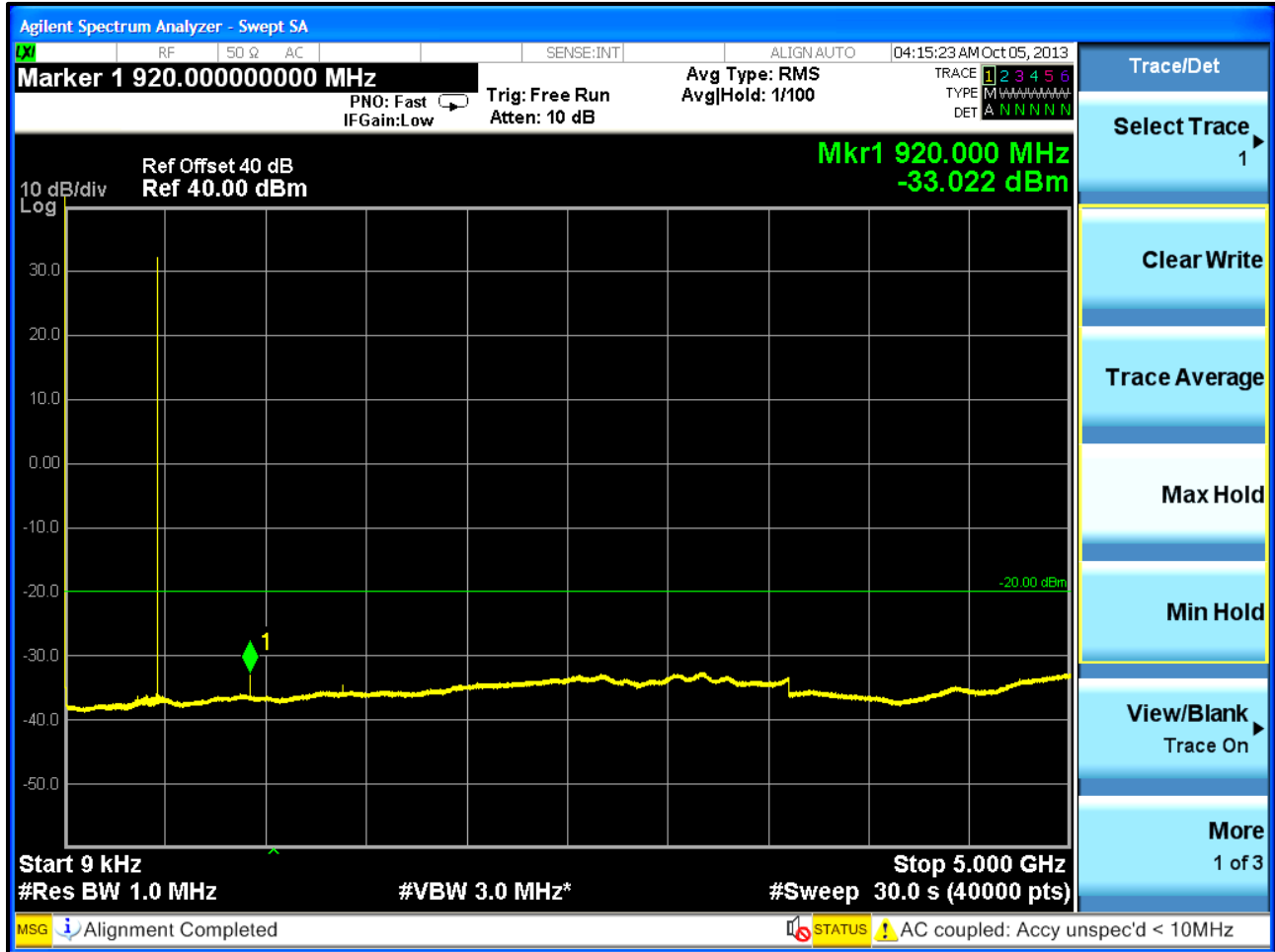

**Plot 5-27: Conducted Spurious Emissions – 460 MHz; Narrowband; 64QAM**



**Plot 5-28: Conducted Spurious Emissions – 460 MHz; Wideband; QPSK**

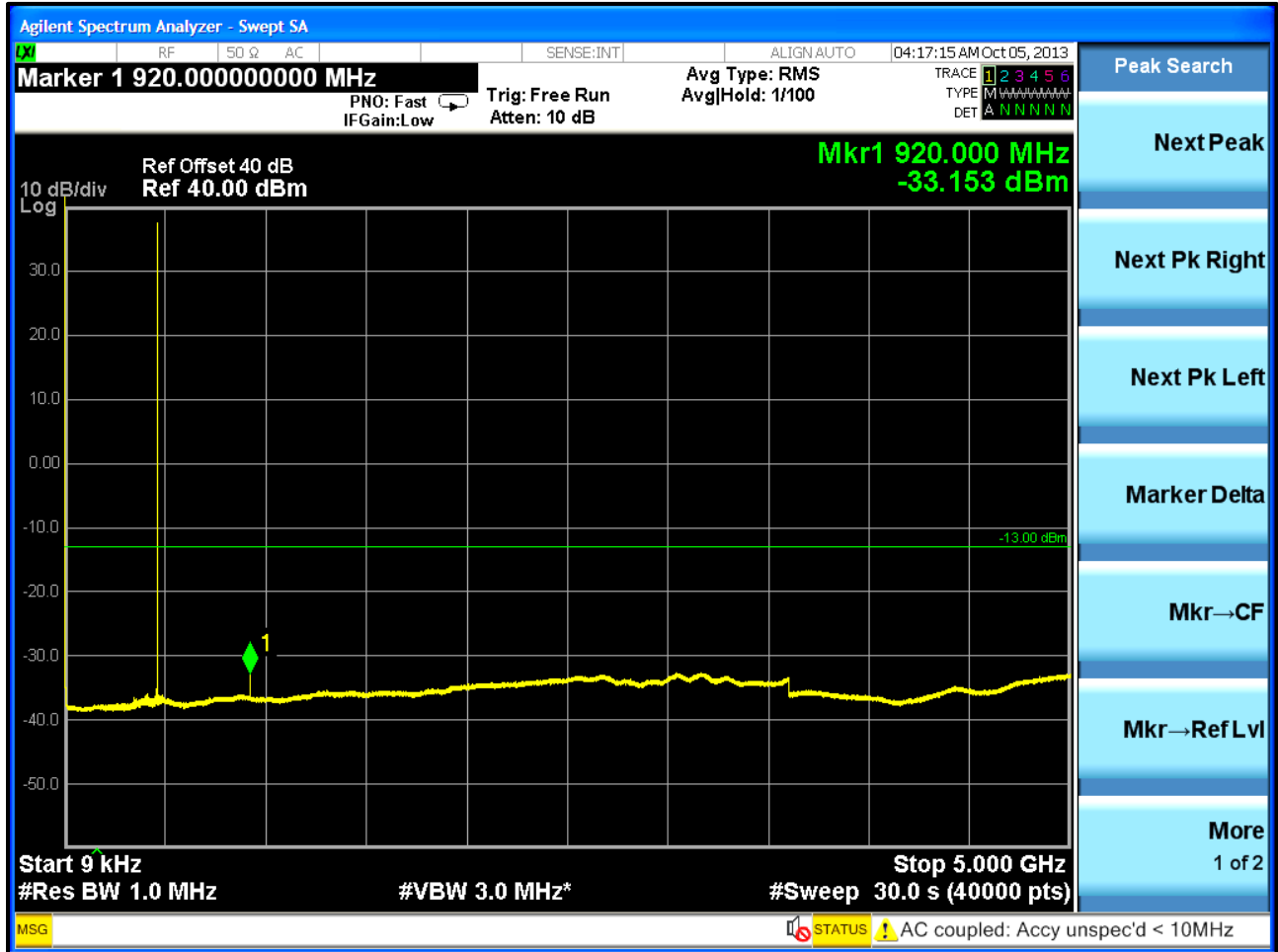

**Plot 5-29: Conducted Spurious Emissions – 460 MHz; Wideband; 16QAM**

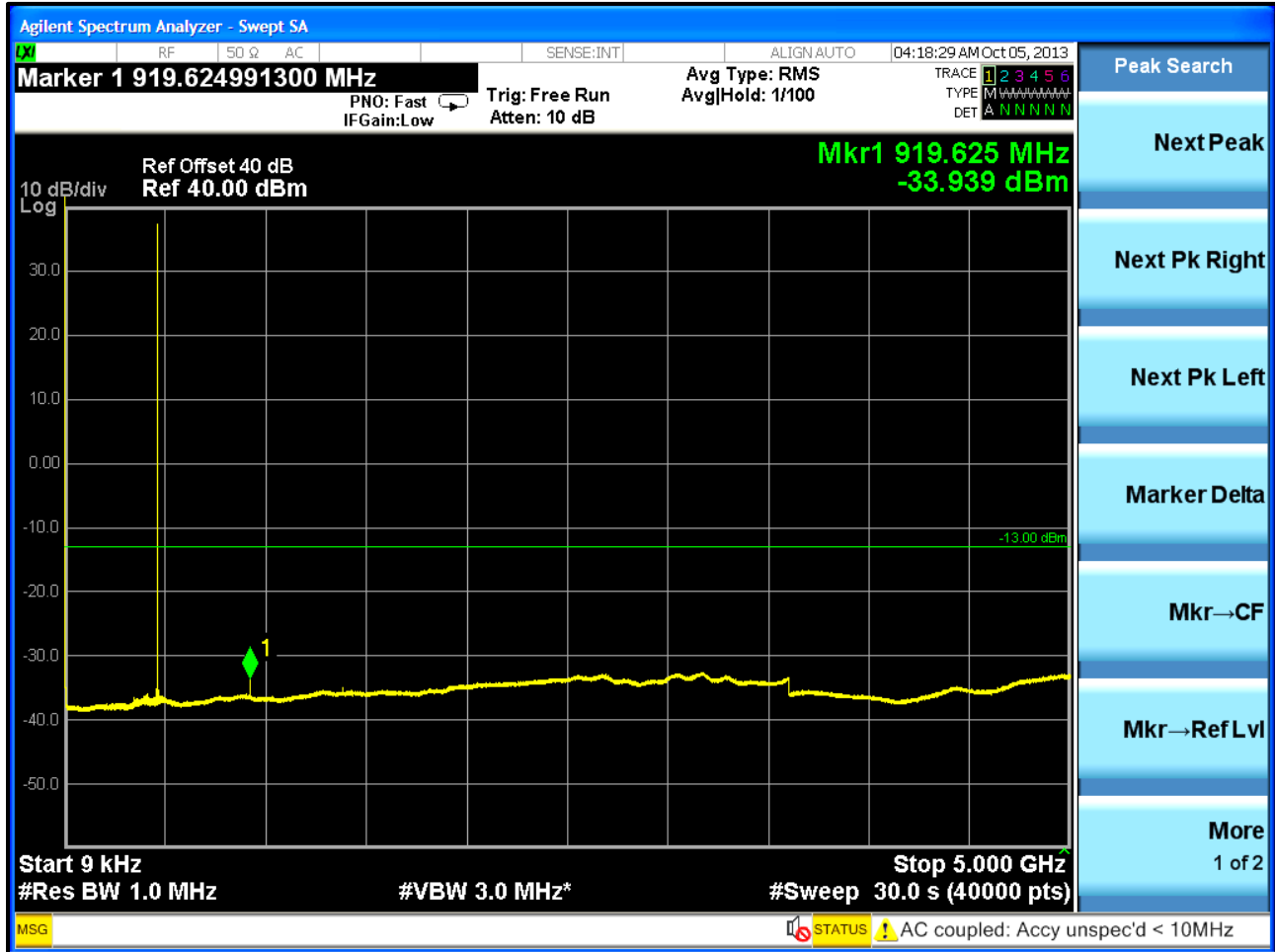

**Plot 5-30: Conducted Spurious Emissions – 460 MHz; Wideband; 64QAM**

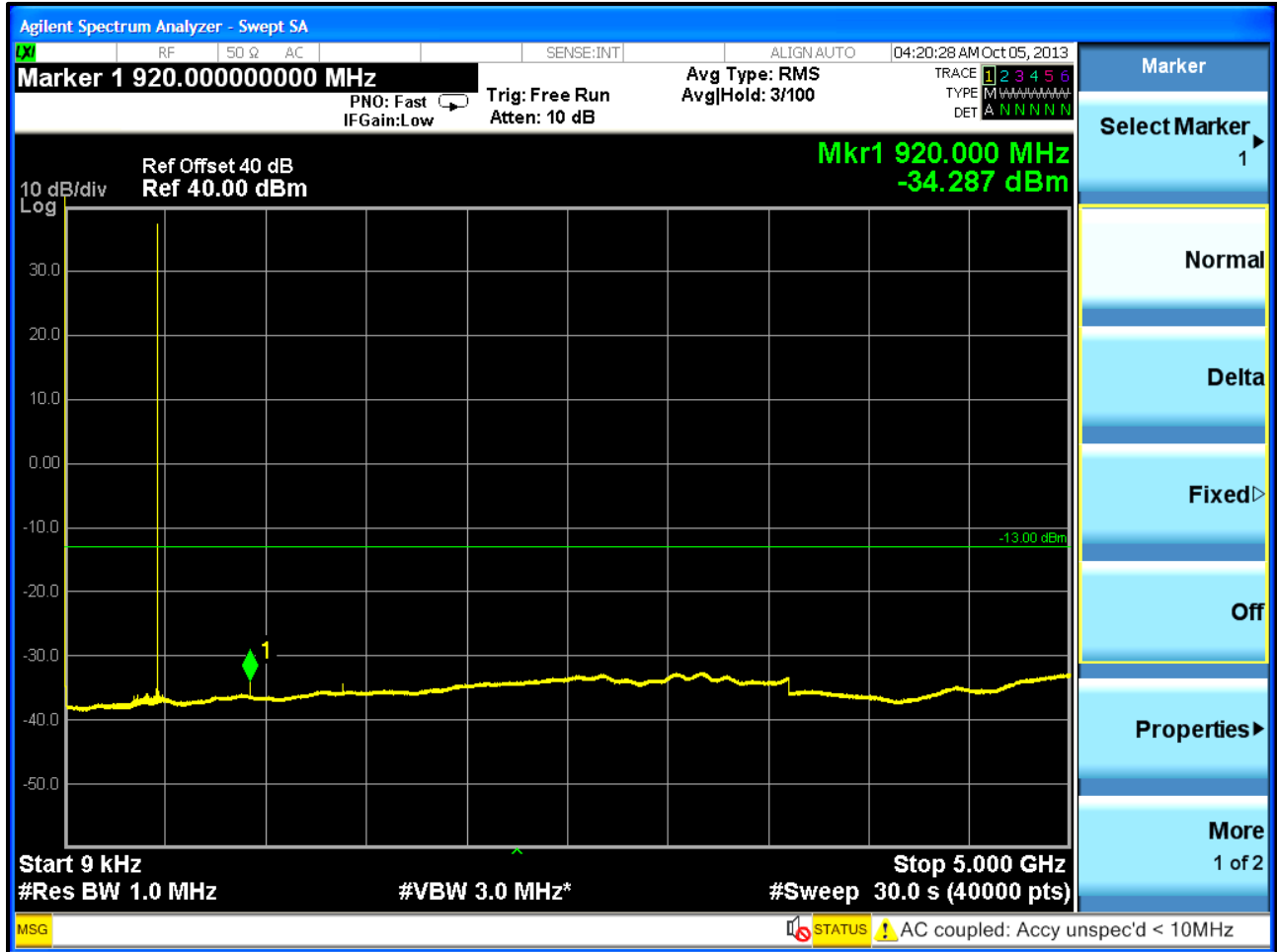

**Plot 5-31: Conducted Spurious Emissions – 470 MHz; Narrowband; QPSK**

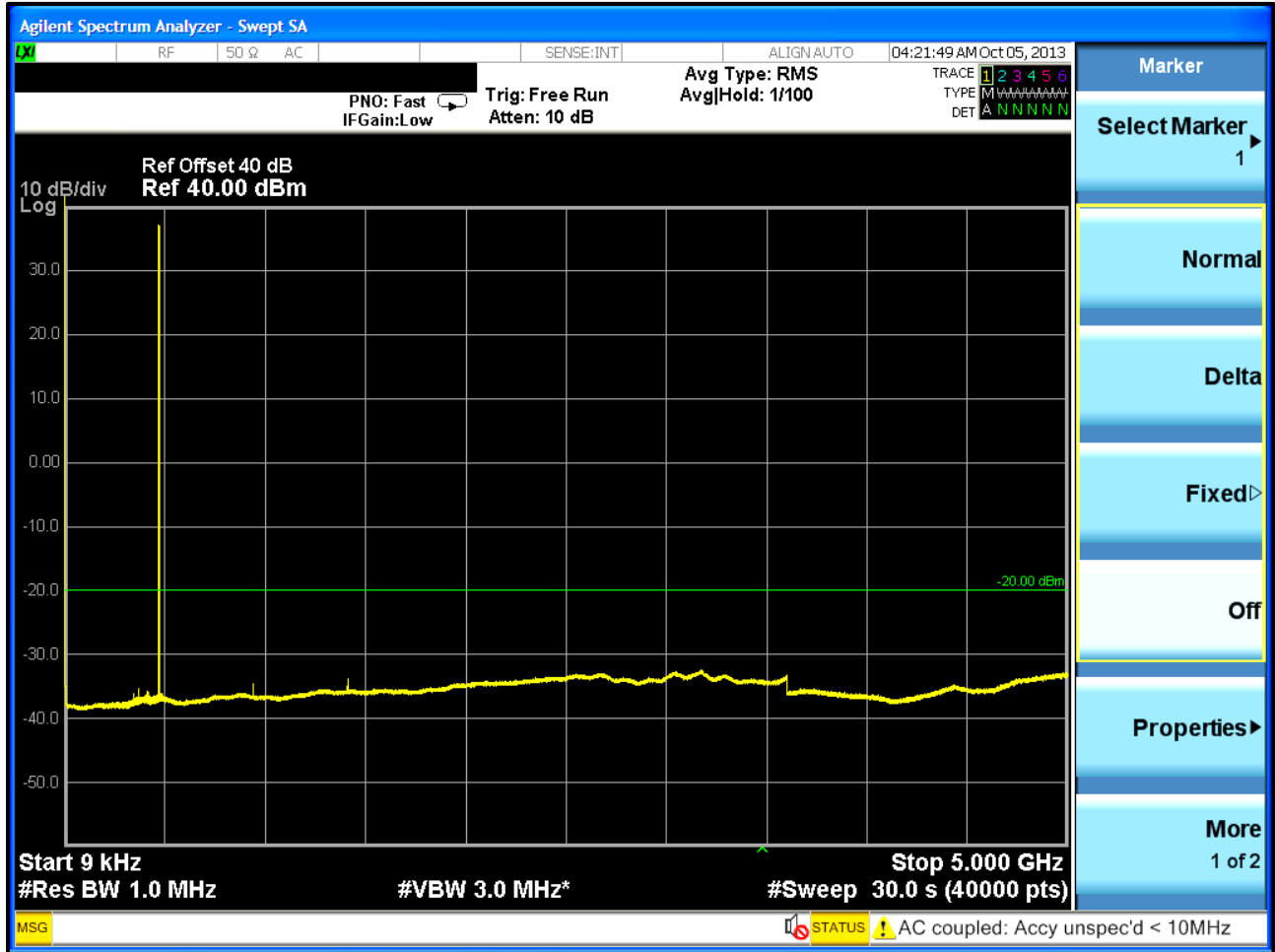



**Plot 5-32: Conducted Spurious Emissions – 470 MHz; Narrowband; 16QAM**

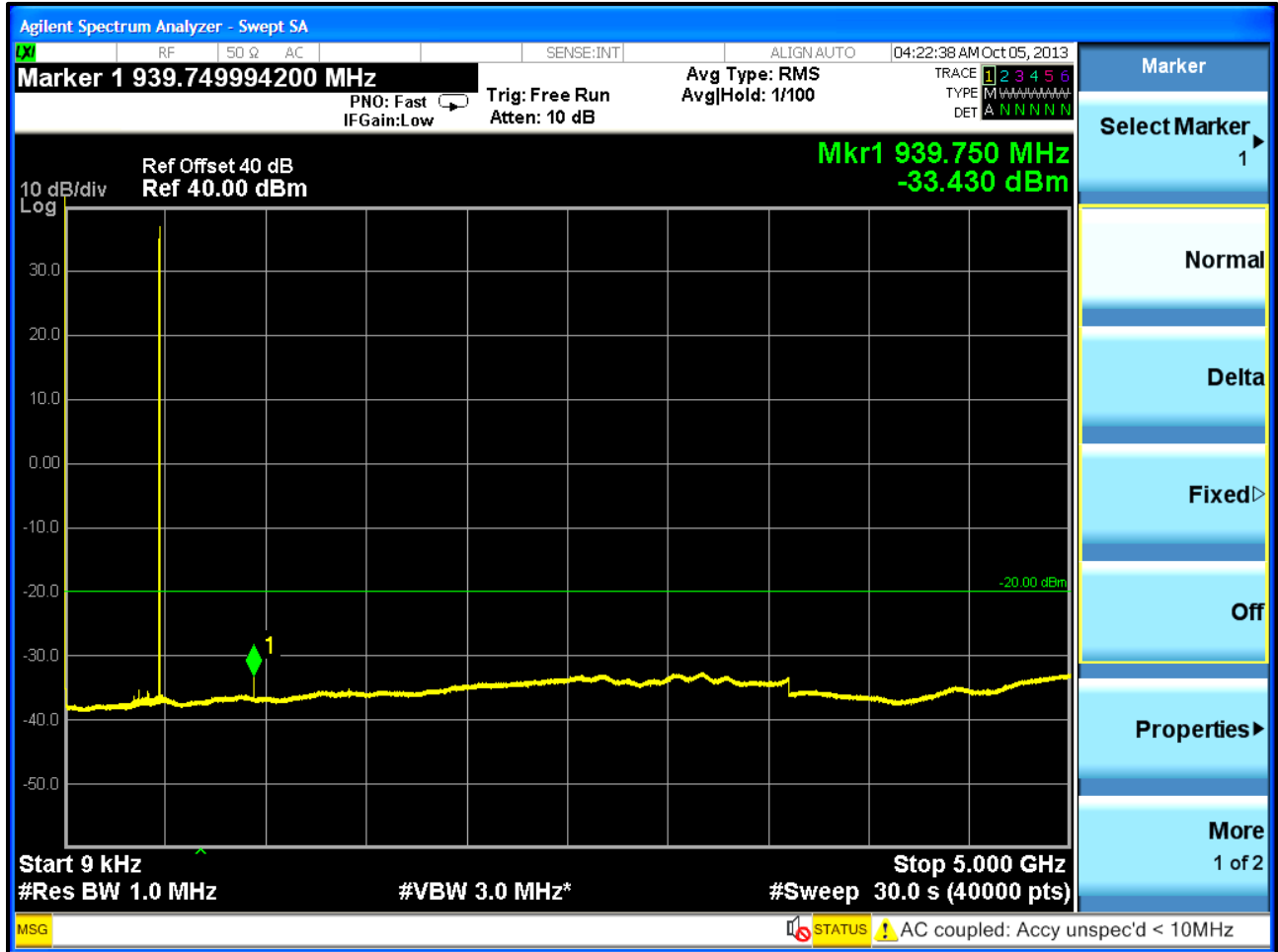

**Plot 5-33: Conducted Spurious Emissions – 470 MHz; Narrowband; 64QAM**

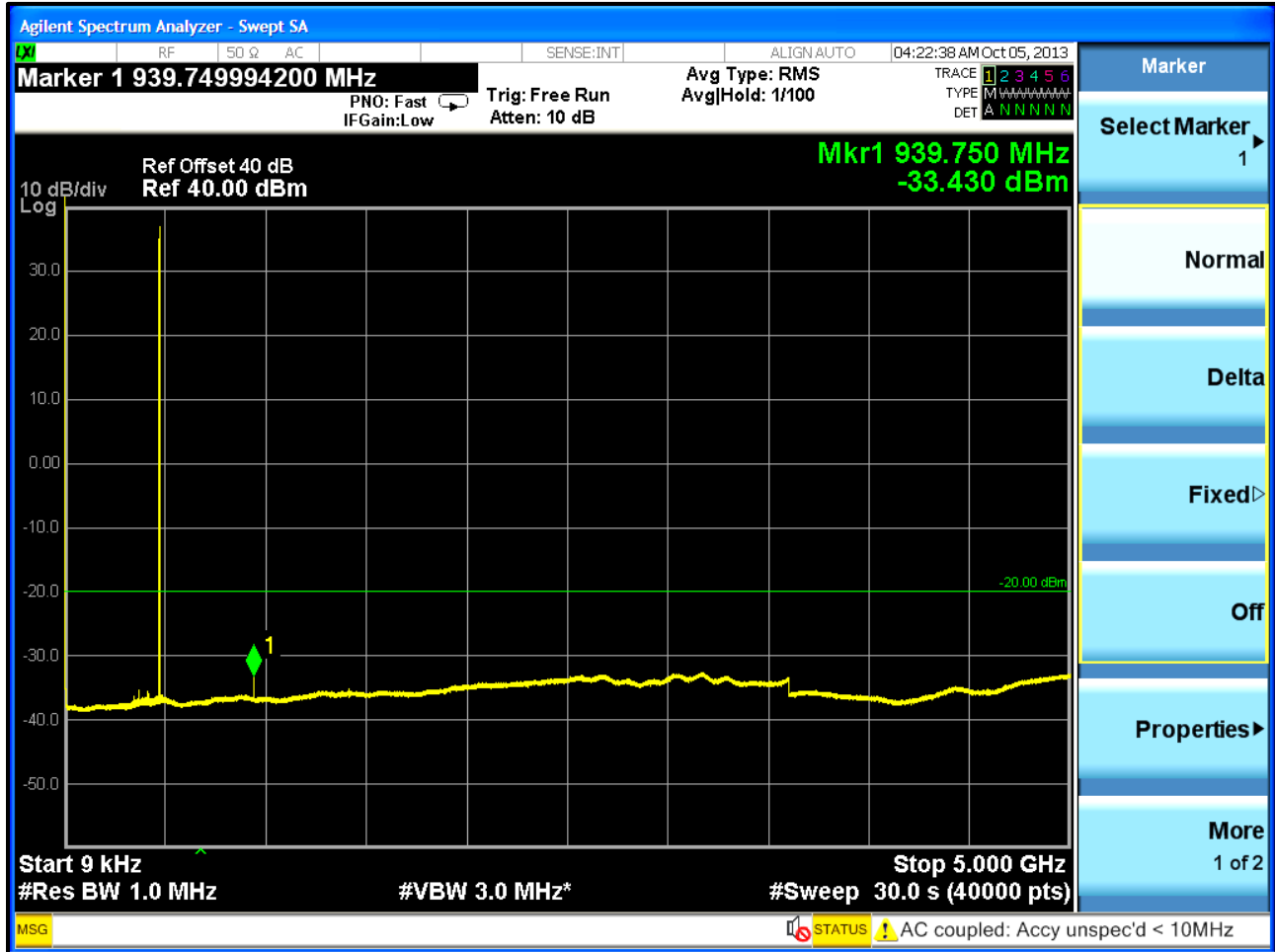

**Plot 5-34: Conducted Spurious Emissions – 470 MHz; Wideband; QPSK**



**Plot 5-35: Conducted Spurious Emissions – 470 MHz; Wideband; 16QAM**



**Plot 5-36: Conducted Spurious Emissions – 470 MHz; Wideband; 64QAM**

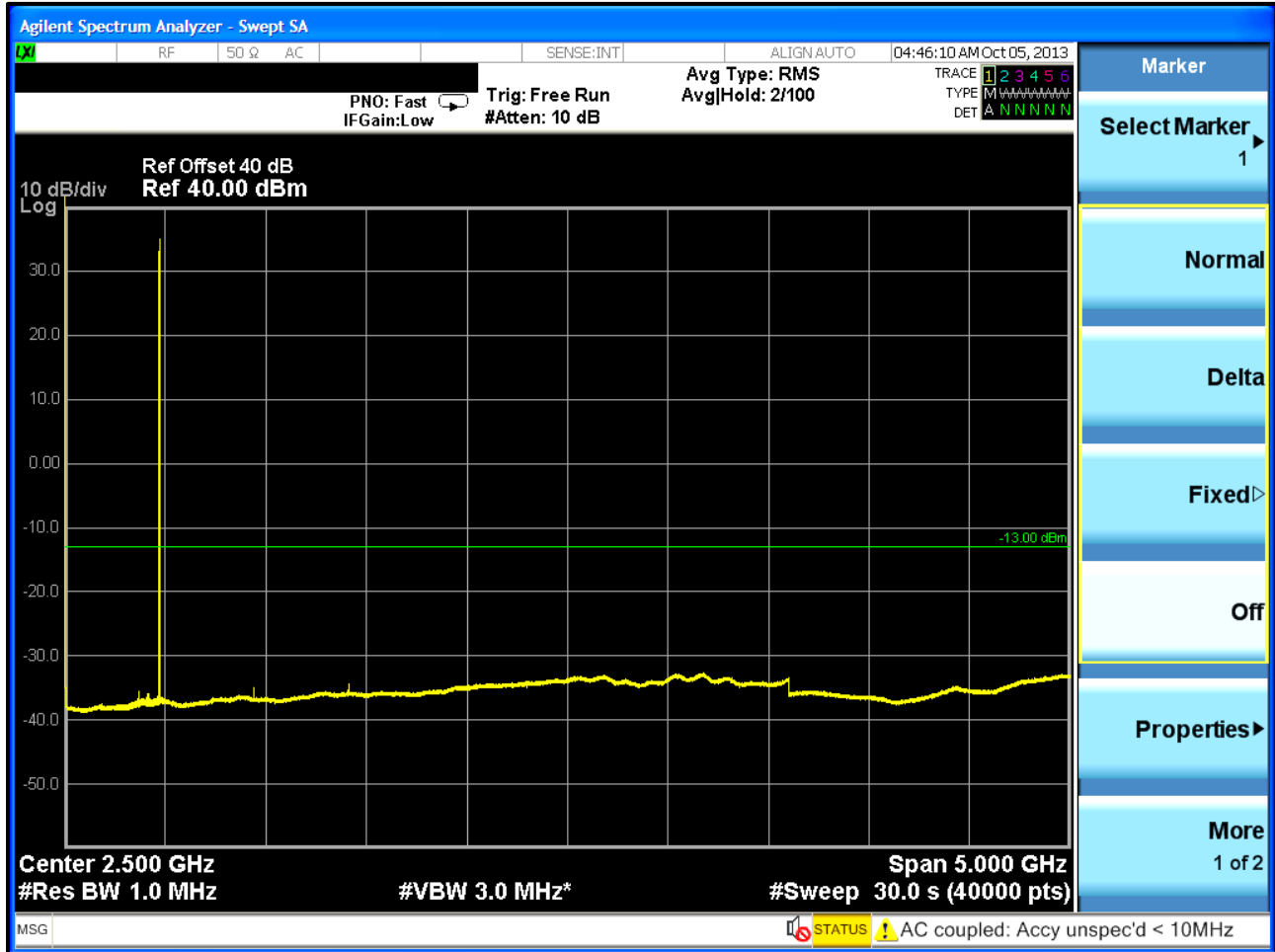

**Table 5-1: Test Equipment Used For Testing Spurious Emissions**

RTL Asset #	Manufacturer	Model	Part Type	Serial Number	Calibration Due Date
901583	Agilent Technologies	N9010A	EXA Signal Analyzer (10 Hz - 26.5 GHz)	MY51250846	4/16/14
901537	Aeroflex	48-40-34	40 dB Attenuator	CB6628	12/14/13

**Test Personnel:**

Daniel Baltzell  
 EMC Test Engineer

Signature

October 5, 2013  
 Date of Test

## 6 FCC Part 90.210(g), 2.1053(a): Field Strength of Spurious Radiation; IC RSS-119 5.8.9.2

### 6.1 Test Procedure

ANSI/TIA-603-2004, section 2.2.12

The device uses digital modulation modulated to its maximum extent using a pseudo-random data sequence.

The spurious emissions levels were measured, and the device under test was replaced by a substitution antenna connected to a signal generator. This signal generator level was then corrected by subtracting the cable loss from the substitution antenna to the signal generator, and the gain of the antenna (dBd) was added to achieve the ERP level, then converted from the corrected signal generator level (dBm) to dBc and compared to the limit.

### 6.2 Test Data

**Table 6-1: Field Strength of Spurious Radiation – 406.1 MHz**

Conducted Power 37.1 dBm; 5.1 W; Limit=50+10LogP=57.1 dBc

Frequency (MHz)	Spectrum Analyzer Level (dBuV)	Signal Generator Level (dBm)	Cable Loss to Transmit Antenna (dB)	Substitution Antenna Gain (dBd)	Corrected Signal Generator Level (dBc)	Margin (dB)
812.2	50.6	-68.5	0.2	0.6	105.2	-48.1
1218.3	36.4	-82.3	0.2	3.3	116.3	-59.2
1624.4	45.7	-69.2	0.3	6.9	99.7	-42.6
2030.5	38.1	-75.8	0.3	6.4	106.8	-49.7
2436.6	28.3	-84.5	0.3	7.6	114.3	-57.2
2842.7	30.3	-81.4	0.4	8.1	110.8	-53.7
3248.8	36.1	-74.6	0.4	7.4	104.8	-47.7
3654.9	25.4	-84.2	0.5	7.4	114.4	-57.3
4061.0	26.0	-80.5	0.4	7.9	110.1	-53.0

**Table 6-2: Field Strength of Spurious Radiation – 418 MHz**

Conducted Power 37.1 dBm; 5.1 W; Limit=50+10LogP=57.1 dBc

Frequency (MHz)	Spectrum Analyzer Level (dBuV)	Signal Generator Level (dBm)	Cable Loss to Transmit Antenna (dB)	Substitution Antenna Gain (dBd)	Corrected Signal Generator Level (dBc)	Margin (dB)
836.0	41.3	-77.8	0.2	0.7	114.4	-57.3
1254.0	32.5	-83.4	0.2	3.7	117.0	-59.9
1672.0	45.9	-68.9	0.3	7.2	99.0	-41.9
2090.0	36.0	-77.7	0.3	6.4	108.8	-51.7
2508.0	23.8	-88.8	0.3	7.6	118.7	-61.6
2926.0	25.3	-86.2	0.4	8.1	115.6	-58.5
3344.0	31.1	-79.3	0.5	7.3	109.5	-52.4
3762.0	25.8	-84.7	0.2	7.2	114.8	-57.7
4180.0	26.4	-79.9	0.9	8.5	109.4	-52.3

**Table 6-3: Field Strength of Spurious Radiation – 430 MHz**

Conducted Power 37.3 dBm; 5.4 W; Limit=50+10LogP=57.3 dBc

Frequency (MHz)	Spectrum Analyzer Level (dBuV)	Signal Generator Level (dBm)	Cable Loss to Transmit Antenna (dB)	Substitution Antenna Gain (dBd)	Corrected Signal Generator Level (dBc)	Margin (dB)
860.0	50.8	-68.8	0.2	0.7	105.6	-48.3
1290.0	25.1	-90.7	0.3	4.1	124.2	-66.9
1720.0	44.8	-69.9	0.4	7.4	100.2	-42.9
2150.0	37.5	-76.0	0.5	6.9	106.9	-49.6
2580.0	30.7	-81.7	0.5	7.5	112.0	-54.7
3010.0	25.1	-86.2	0.6	7.8	116.3	-59.0
3440.0	35.0	-75.2	0.6	7.5	105.6	-48.3
3870.0	19.5	-89.5	0.7	7.2	120.3	-63.0
4300.0	21.1	-85.5	0.8	8.8	114.8	-57.5

**Table 6-4: Field Strength of Spurious Radiation – 450 MHz**

Conducted Power 37.1 dBm; 5.1 W; Limit=50+10LogP=57.1 dBc

Frequency (MHz)	Spectrum Analyzer Level (dBuV)	Signal Generator Level (dBm)	Cable Loss to Transmit Antenna (dB)	Substitution Antenna Gain (dBd)	Corrected Signal Generator Level (dBc)	Margin (dB)
900.0	43.6	-73.2	0.3	0.9	109.7	-52.6
1350.0	30.1	-85.5	0.2	4.5	118.3	-61.2
1800.0	36.5	-78.0	0.3	7.5	107.9	-50.8
2250.0	35.9	-77.4	0.3	7.5	107.3	-50.2
2700.0	35.1	-77.0	0.4	7.8	106.7	-49.6
3150.0	21.1	-89.8	0.4	7.4	119.9	-62.8
3600.0	28.6	-81.1	0.2	7.5	111.0	-53.9
4050.0	19.4	-86.8	0.5	7.9	116.5	-59.4
4500.0	18.7	-87.7	0.7	8.9	116.6	-59.5

**Table 6-5: Field Strength of Spurious Radiation – 460 MHz**

Conducted Power 37.2 dBm; 5.3 W; Limit=50+10LogP=57.2 dBc

Frequency (MHz)	Spectrum Analyzer Level (dBuV)	Signal Generator Level (dBm)	Cable Loss to Transmit Antenna (dB)	Substitution Antenna Gain (dBd)	Corrected Signal Generator Level (dBc)	Margin (dB)
920.0	46.7	-70.1	0.3	1.0	106.6	-49.4
1380.0	40.5	-75.1	0.2	4.6	107.9	-50.7
1840.0	34.6	-79.8	0.2	7.2	110.1	-52.9
2300.0	38.7	-74.5	0.3	7.7	104.2	-47.0
2760.0	28.9	-83.0	0.4	8.0	112.6	-55.4
3220.0	21.3	-89.4	0.4	7.4	119.7	-62.5
3680.0	27.4	-82.1	0.7	7.3	112.6	-55.4
4140.0	19.0	-87.3	0.5	8.3	116.7	-59.5
4600.0	19.8	-86.7	0.3	9.0	115.3	-58.1



**Table 6-6: Field Strength of Spurious Radiation – 470 MHz**

Conducted Power 37.0 dBm; 5.0 W; Limit=50+10LogP=57.0 dBc

Frequency (MHz)	Spectrum Analyzer Level (dBuV)	Signal Generator Level (dBm)	Cable Loss to Transmit Antenna (dB)	Substitution Antenna Gain (dBd)	Corrected Signal Generator Level (dBc)	Margin (dB)
940.0	46.7	-70.0	0.3	1.1	106.2	-49.2
1410.0	32.1	-83.4	0.2	4.8	115.8	-58.8
1880.0	36.1	-78.2	0.3	6.8	108.7	-51.7
2350.0	36.3	-76.7	0.3	7.7	106.3	-49.3
2820.0	31.9	-79.9	0.4	8.1	109.2	-52.2
3290.0	19.6	-91.0	0.4	7.3	121.1	-64.1
3760.0	25.5	-83.8	0.2	7.2	113.8	-56.8
4230.0	18.3	-88.0	1.0	8.7	117.3	-60.3
4700.0	18.8	-87.7	1.0	9.1	116.6	-59.6

**Table 6-7: Test Equipment Used For Testing Field Strength of Spurious Radiation**

RTL Asset #	Manufacturer	Model	Part Type	Serial Number	Calibration Due Date
900932	Hewlett Packard	8449B OPT H02	Preamplifier (1 - 26.5 GHz)	3008A00505	8/27/14
900878	Rhein Tech Laboratories	AM3-1197-0005	3 meter Antenna Mast, polarizing	OATS1	N/A
901592	Insulated Wire Inc.	KPS-1503-3600-KPR	SMK RF Cables 20'	NA	8/27/14
901593	Insulated Wire Inc.	KPS-1503-360-KPR	SMK RF Cables 36"	NA	8/27/14
901594	Insulated Wire Inc.	KPS-1503-360-KPR	SMK RF Cables 36"	NA	8/27/14
901242	Rhein Tech Laboratories	WRT-000-0003	Wood rotating table	N/A	N/A
900791	Chase	CBL6111B	Bilog Antenna (30 MHz – 2000 MHz)	N/A	2/1/14
900321	EMCO	3161-03	Horn Antennas (4 – 8 GHz)	9508-1020	4/19/14
900772	EMCO	3161-02	Horn Antenna (2 - 4 GHz)	9804-1044	4/19/14
900928	Hewlett Packard	83752A	Synthesized Sweeper (0.01 - 20 GHz)	3610A00866	3/20/15
900905	Rhein Tech Laboratories	PR-1040	OATS 1 Preamplifier 40dB (30 MHz – 2 GHz)	1006	9/4/14
900323	EMCO	3160-07	Horn Antenna (8.2 - 12.4 GHz)	9605-1054	4/19/14
901583	Agilent Technologies	N9010A	EXA Signal Analyzer (10 Hz - 26.5 GHz)	MY51250846	4/16/14

**Test Personnel:**

Daniel Baltzell  
 Test Engineer

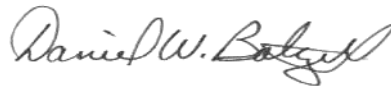

Signature

October 7, 2013  
 Date of Tests

**7 FCC Part 2.1049(c)(1), 90.210: Occupied Bandwidth; IC RSS-119 5.5**

Occupied Bandwidth - Compliance with the Emission Masks

**7.1 Test Procedure**

ANSI/TIA/EIA-603-2004, section 2.2.11

Device with digital modulation: Modulated to its maximum extent using a pseudo-random data sequence.

<b>Applicable Emission Masks</b>		
<b>Frequency Band (MHz)</b>	<b>Mask for Equipment With Audio Low Pass Filter</b>	<b>Mask for Equipment Without Audio Low Pass Filter</b>
Below 25 <sup>1</sup> .....	A or B	A or C
25–50.....	B	C
72–76.....	B	C
150–174 <sup>2</sup> .....	B, D, or E	C, D, or E
150 Paging-only .....	B	C
220–222 .....	F	F
421–512 <sup>2</sup> .....	B, D, or E	C, D, or E
450 Paging-only .....	B	G
806–809/851–854 .....	B	H
809–824/854–869 <sup>3</sup> .....	B	G
896–901/935–940 .....	I	J
902–928 .....	K	K
929–930 .....	B	G
4940–4990 MHz .....	L or M	L or M
5850–5925 <sup>4</sup> .....	B	C
All other bands	B	C

<sup>1</sup> Equipment using single sideband J3E emission must meet the requirements of Emission Mask A. Equipment using other emissions must meet the requirements of Emission Mask B or C, as applicable.  
<sup>2</sup> Equipment designed to operate with a 25 kHz channel bandwidth must meet the requirements of Emission Mask B or C, as applicable. Equipment designed to operate with a 12.5 kHz channel bandwidth must meet the requirements of Emission Mask D, and equipment designed to operate with a 6.25 kHz channel bandwidth must meet the requirements of Emission Mask E.  
<sup>3</sup> Equipment used in this licensed to EA or non-EA systems shall comply with the emission mask provisions of §90.691.  
<sup>4</sup> DSRCS Roadside Unit equipment in the 5850–5925 MHz band is governed under subpart M of this part.

## 7.2 Test Data

Plot 7-1: Occupied Bandwidth – 406.1 MHz; Mask D

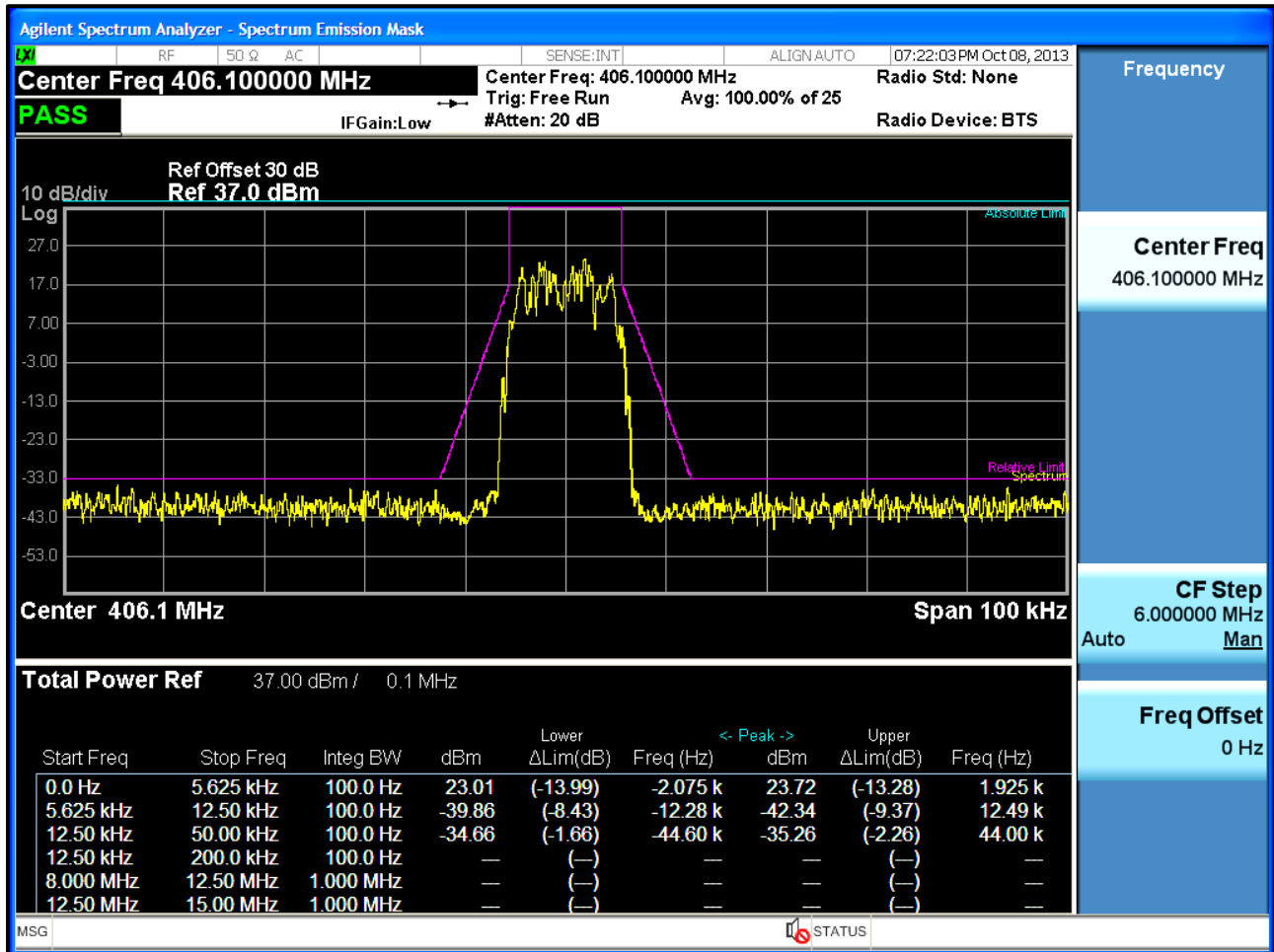

**Plot 7-2: Occupied Bandwidth – 418.0 MHz; Mask D**

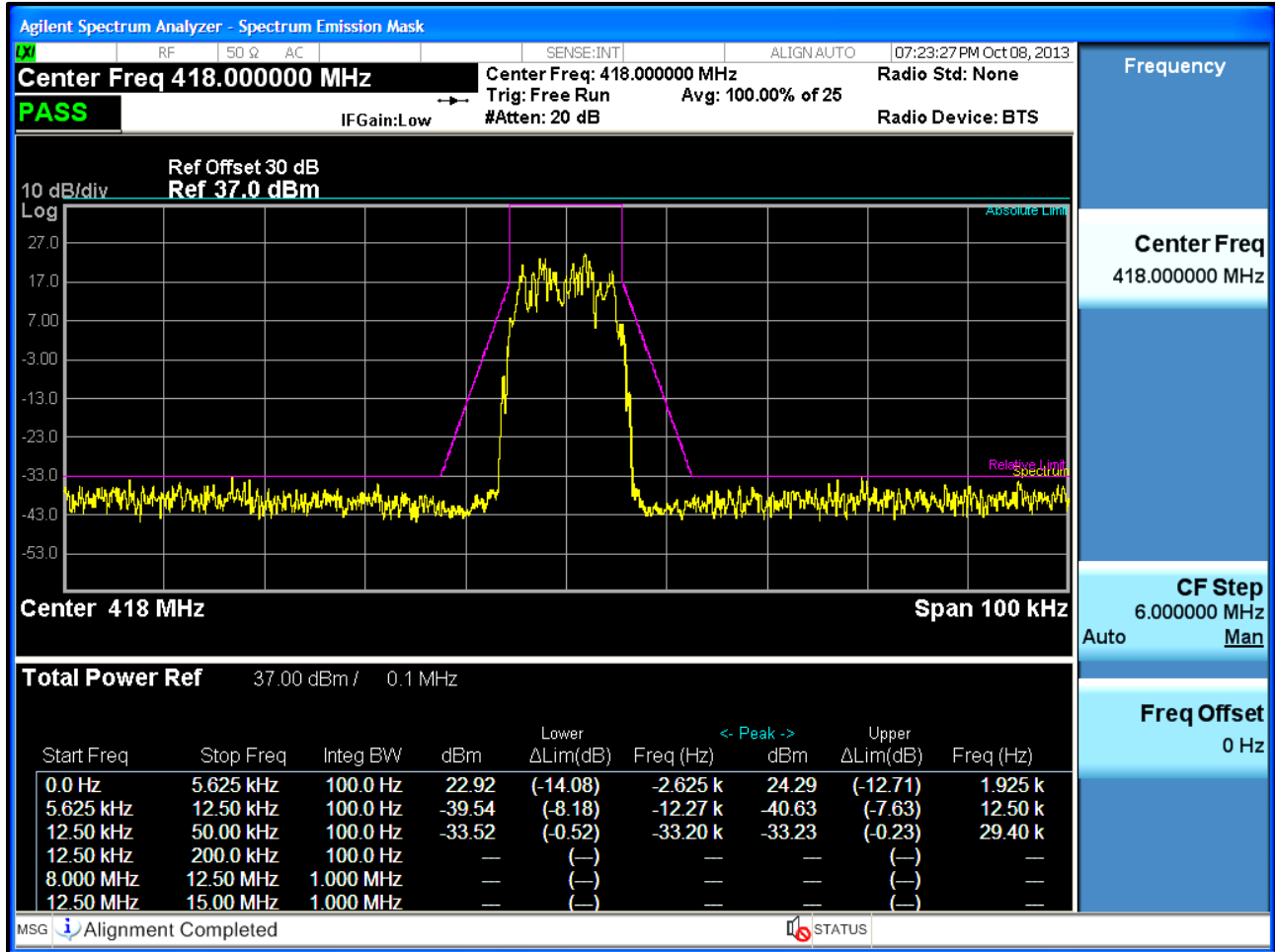

**Plot 7-3: Occupied Bandwidth – 430.0 MHz; Mask D**

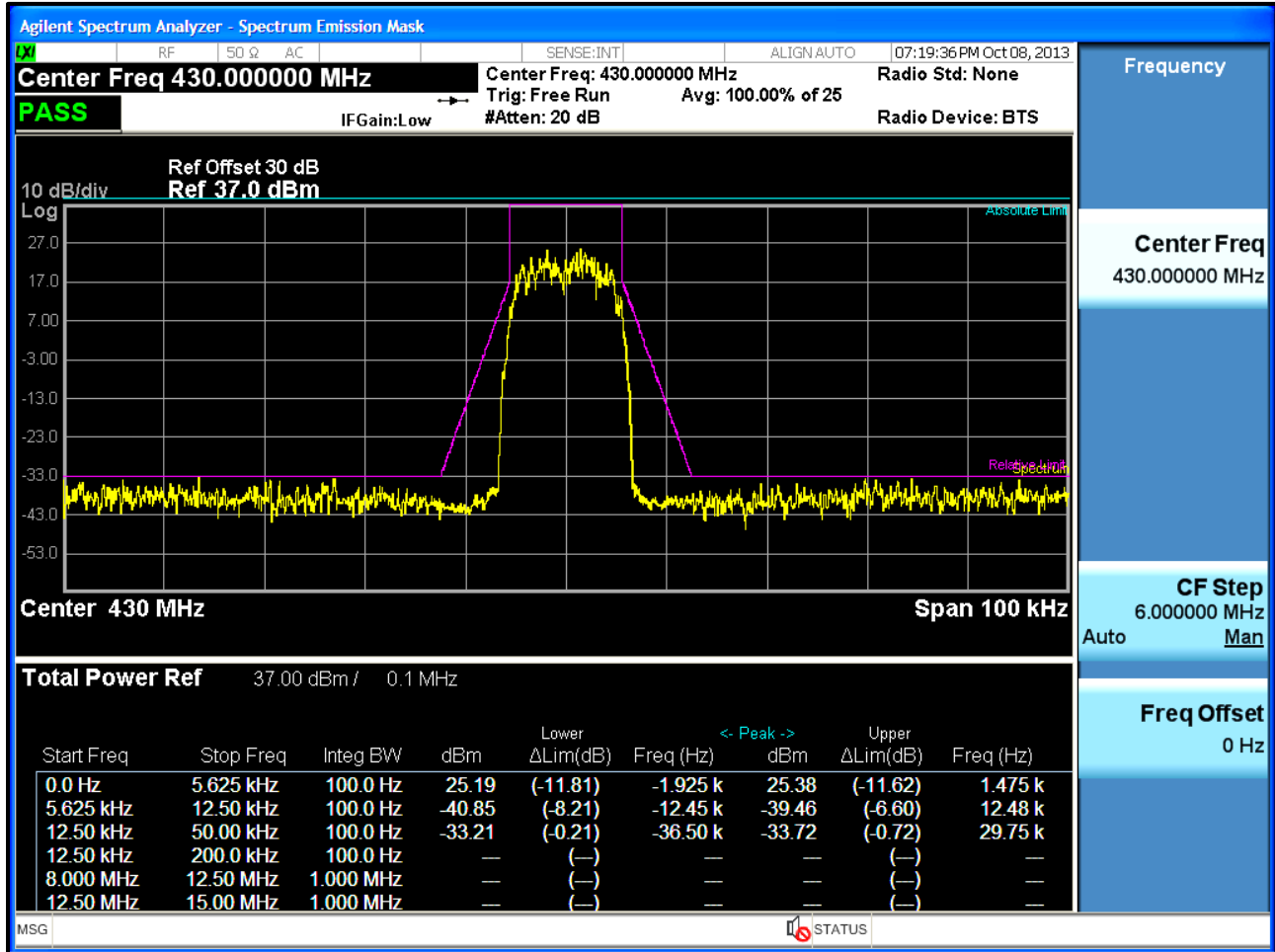

**Plot 7-4: Occupied Bandwidth – 450.0 MHz; Mask D**

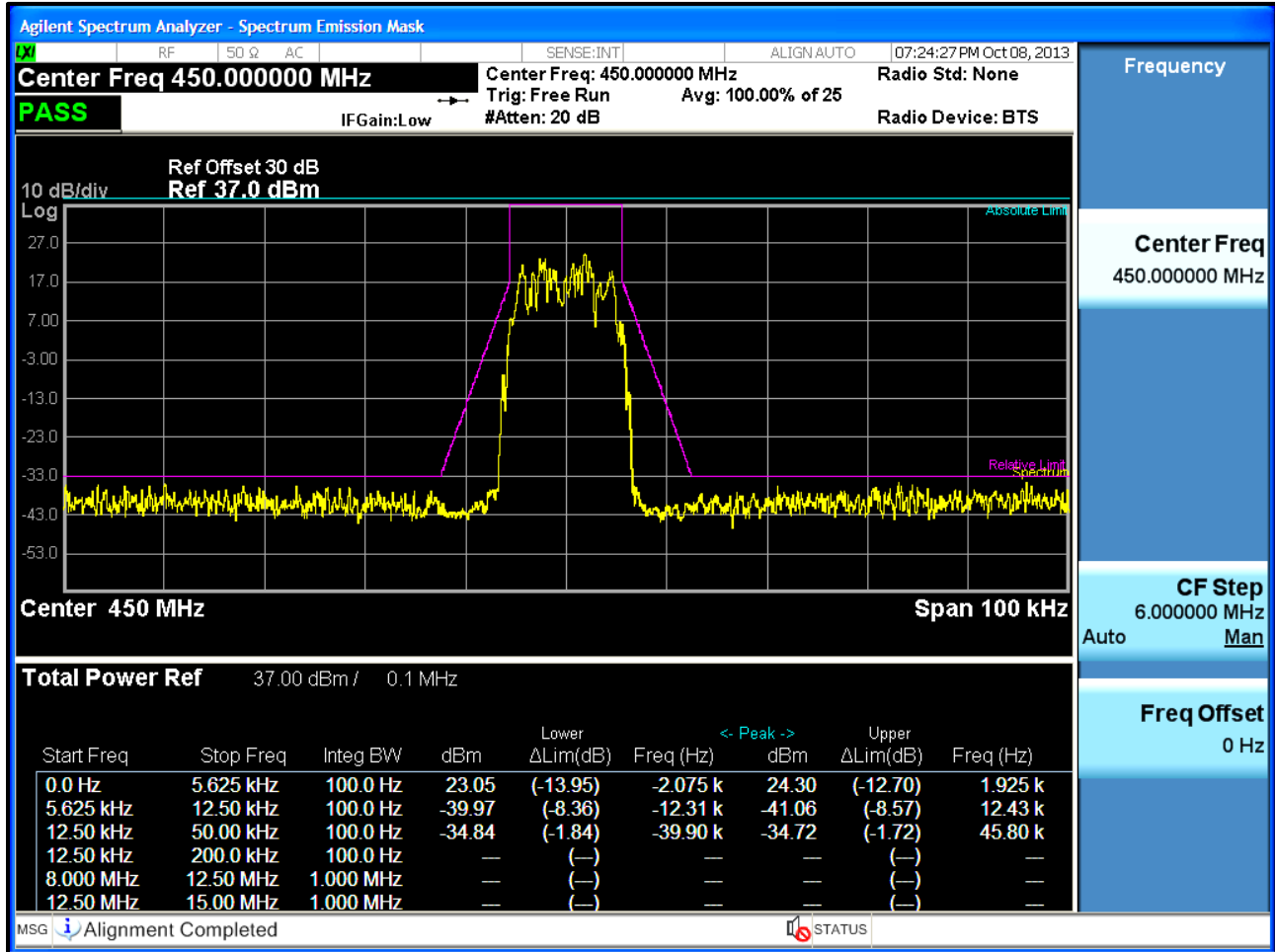

**Plot 7-5: Occupied Bandwidth – 460.0 MHz; Mask D**

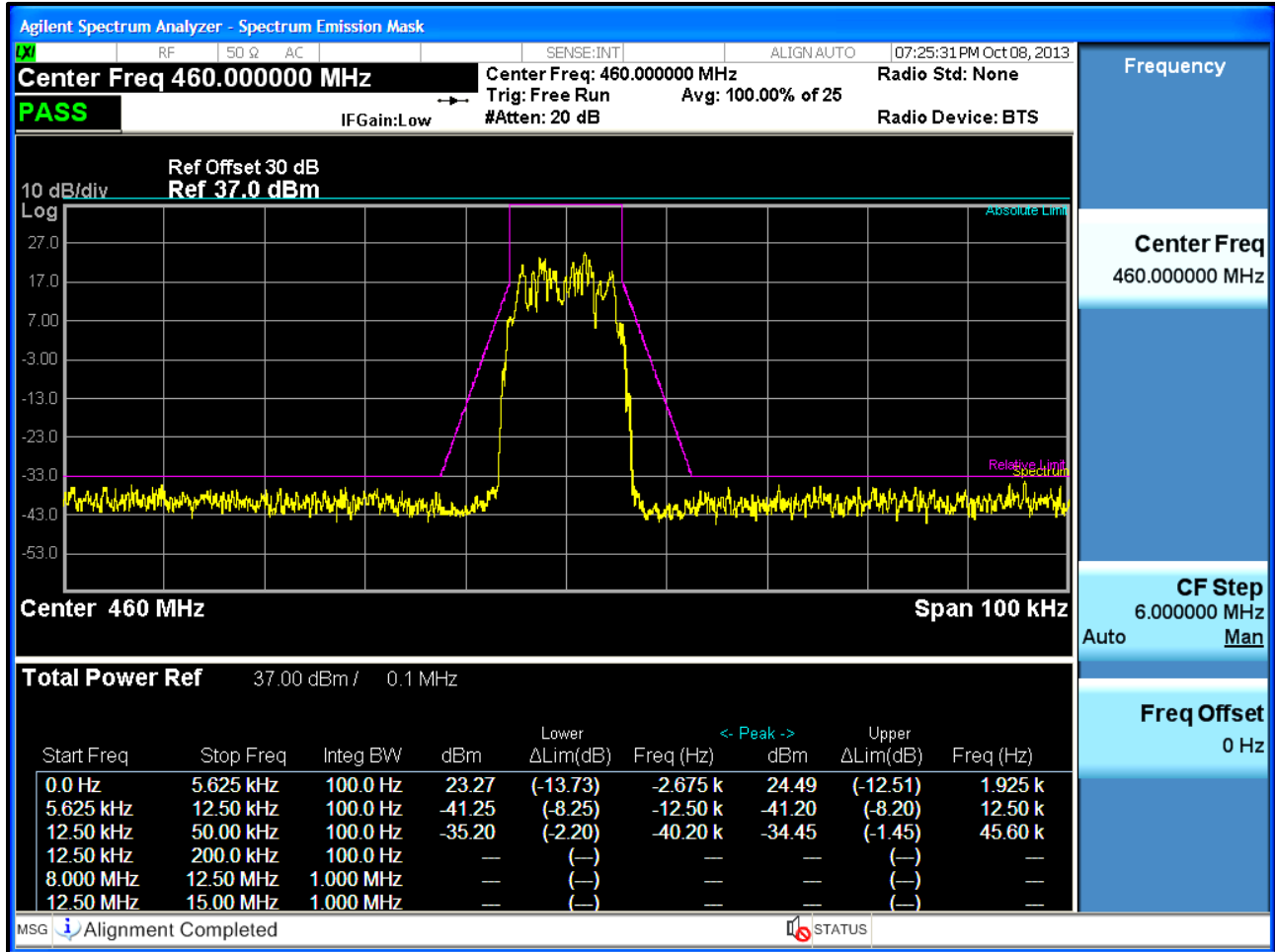



**Plot 7-6: Occupied Bandwidth – 470.0 MHz; Mask D**

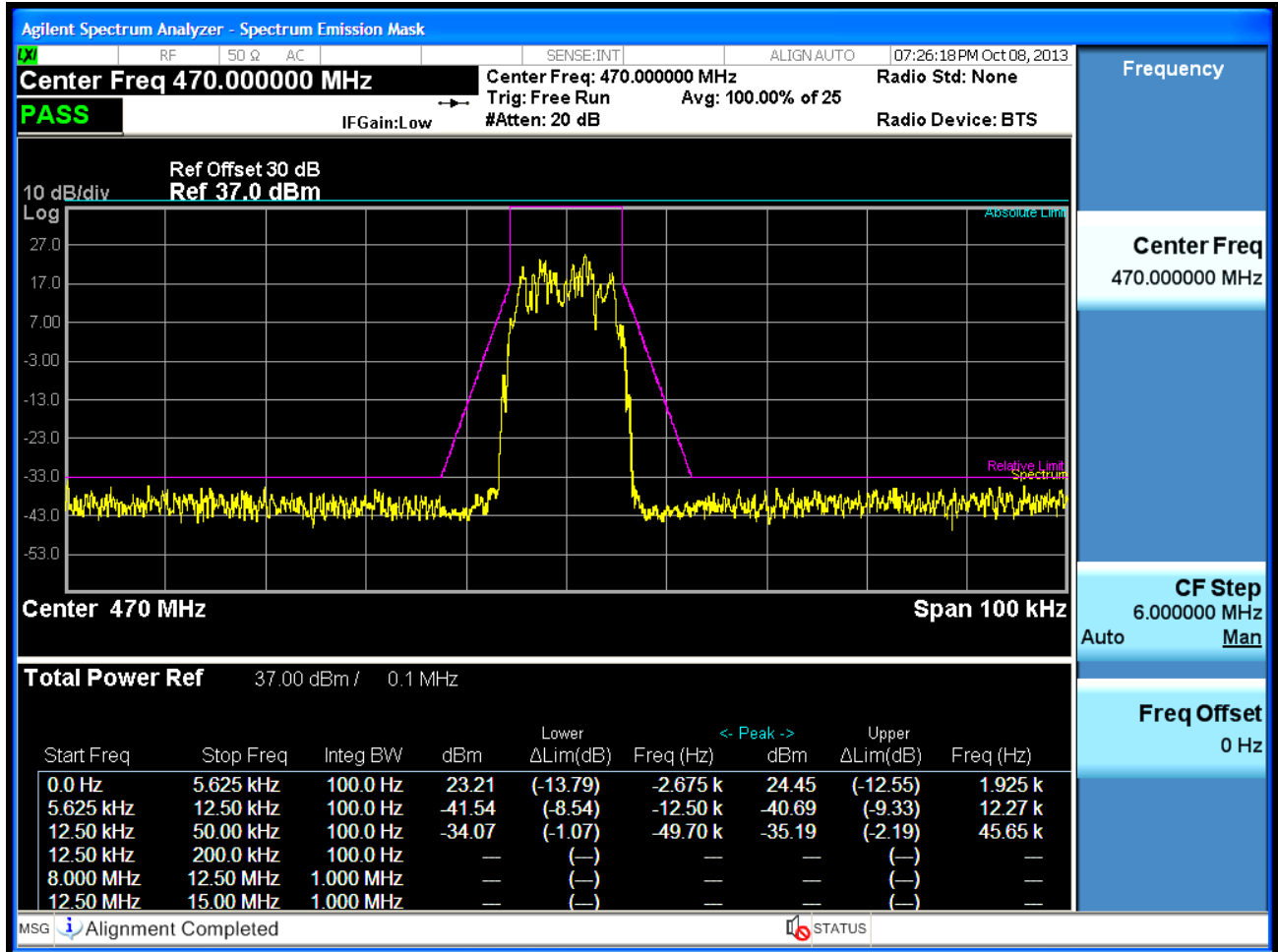

**Plot 7-7: Occupied Bandwidth – 406.1 MHz; Mask C; 25 kHz Channel Spacing**

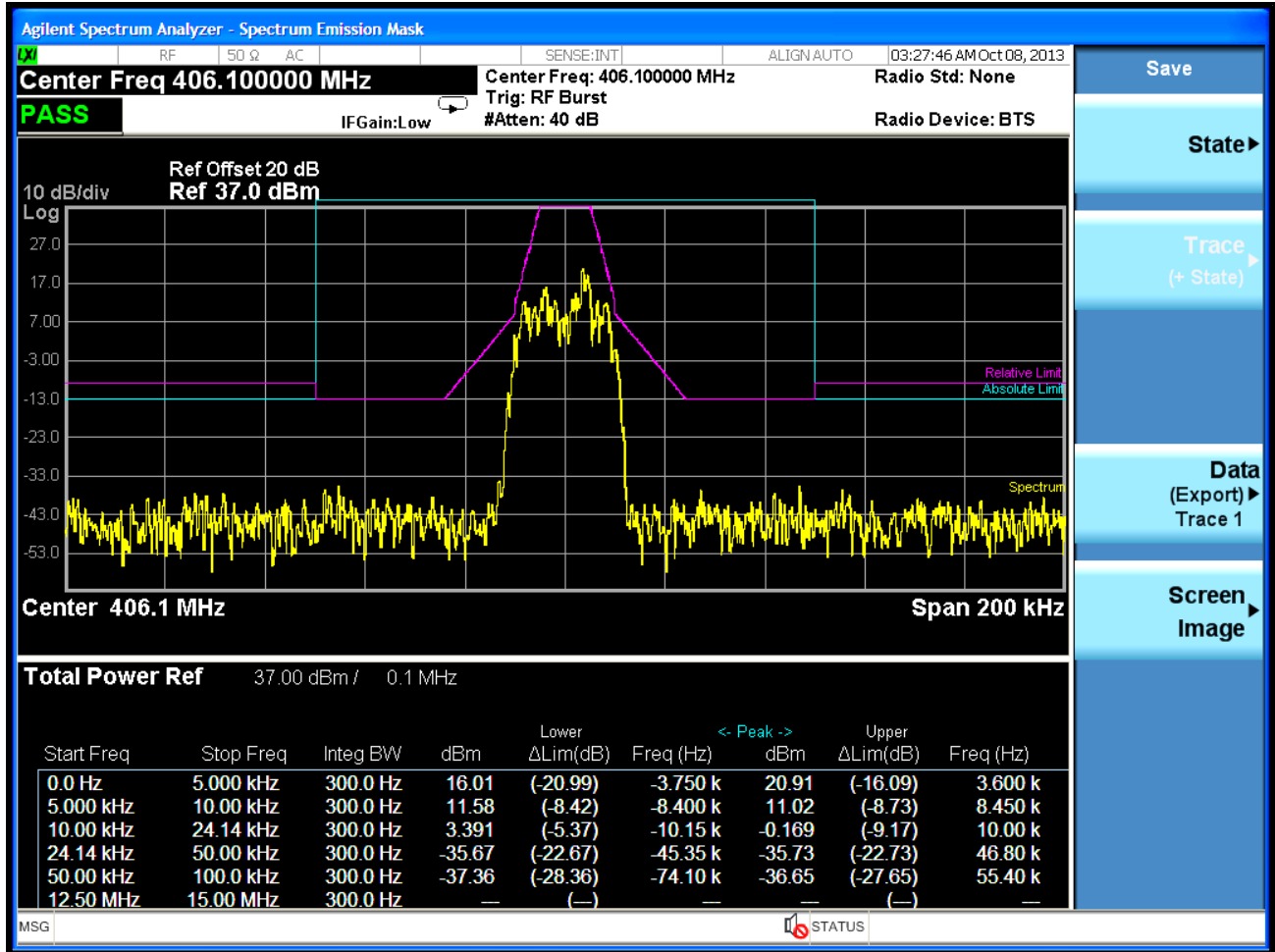

**Plot 7-8: Occupied Bandwidth – 418.0 MHz; Mask C; 25 kHz Channel Spacing**

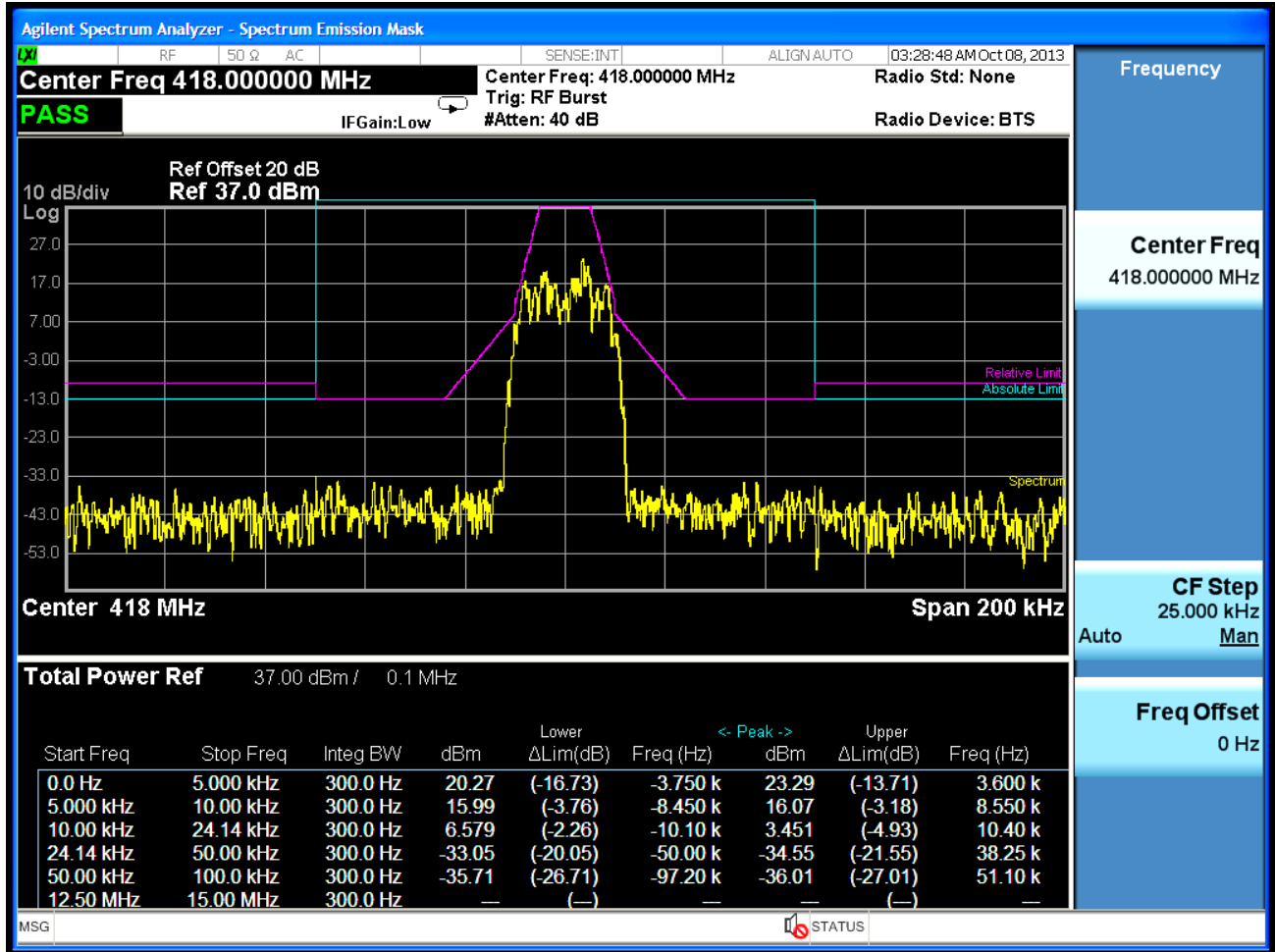

**Plot 7-9: Occupied Bandwidth – 430.0 MHz; Mask C; 25 kHz Channel Spacing**

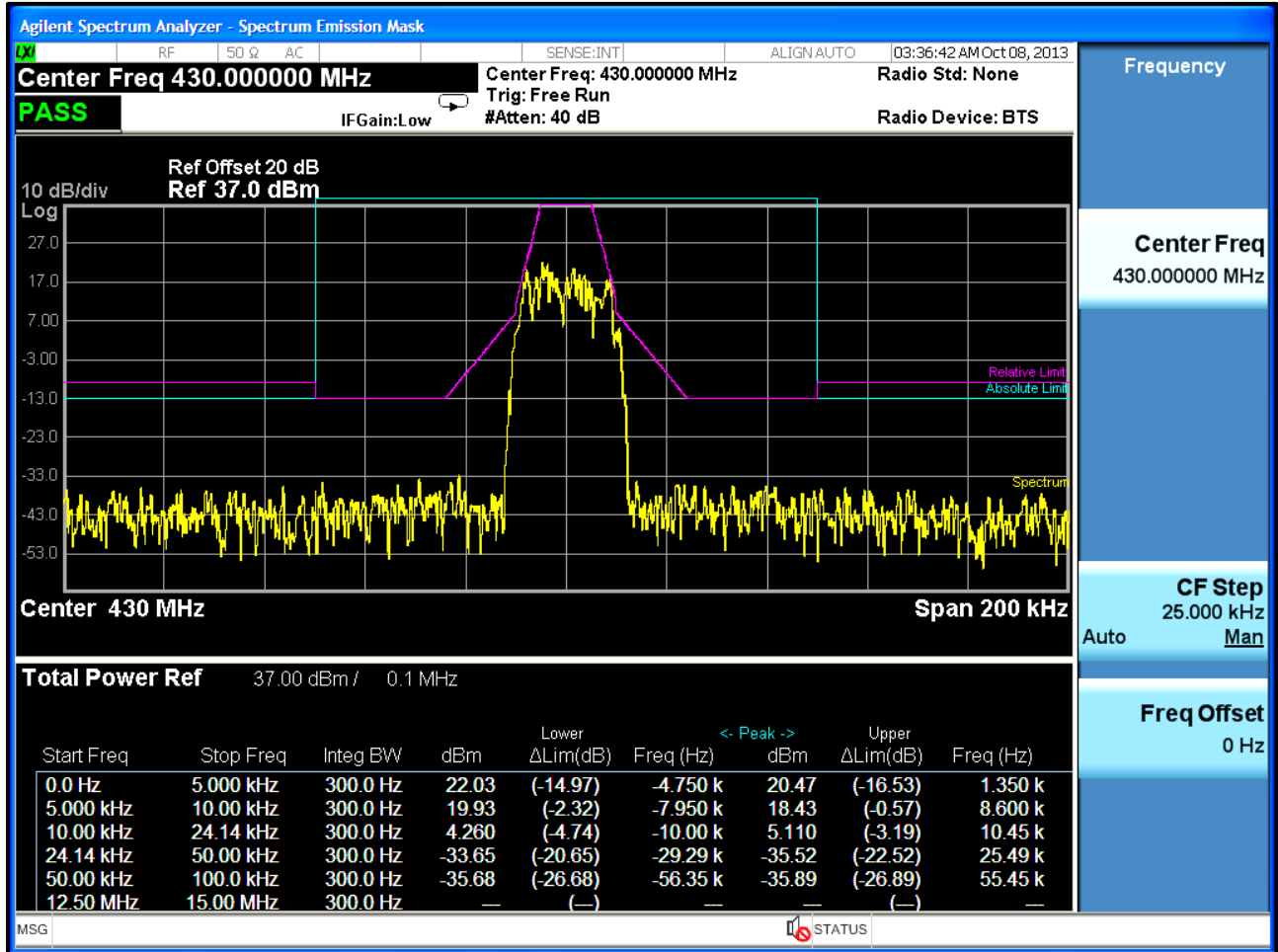

**Plot 7-10: Occupied Bandwidth – 450.0 MHz; Mask C; 25 kHz Channel Spacing**

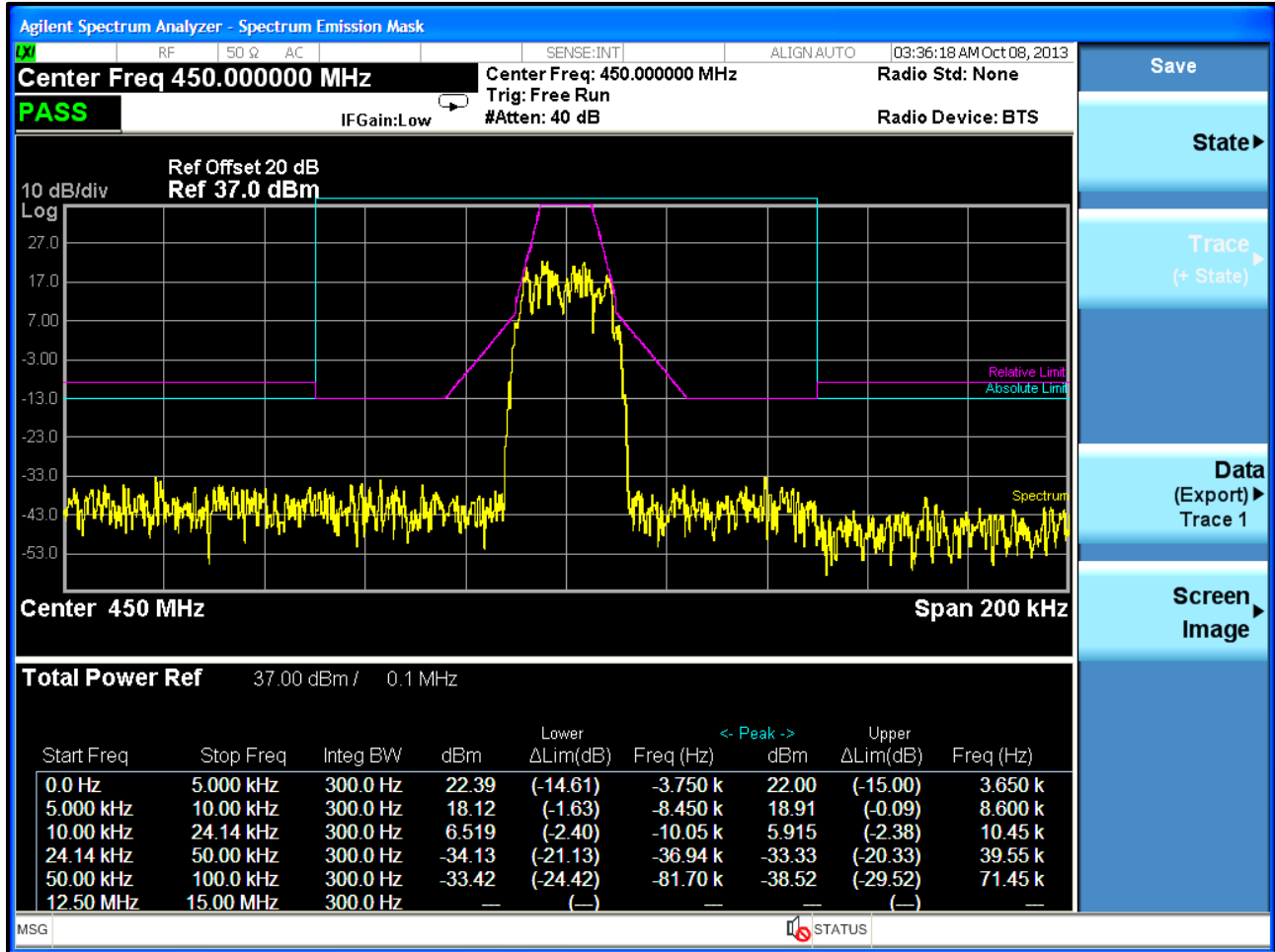

**Plot 7-11: Occupied Bandwidth – 460.0 MHz; Mask C; 25 kHz Channel Spacing**

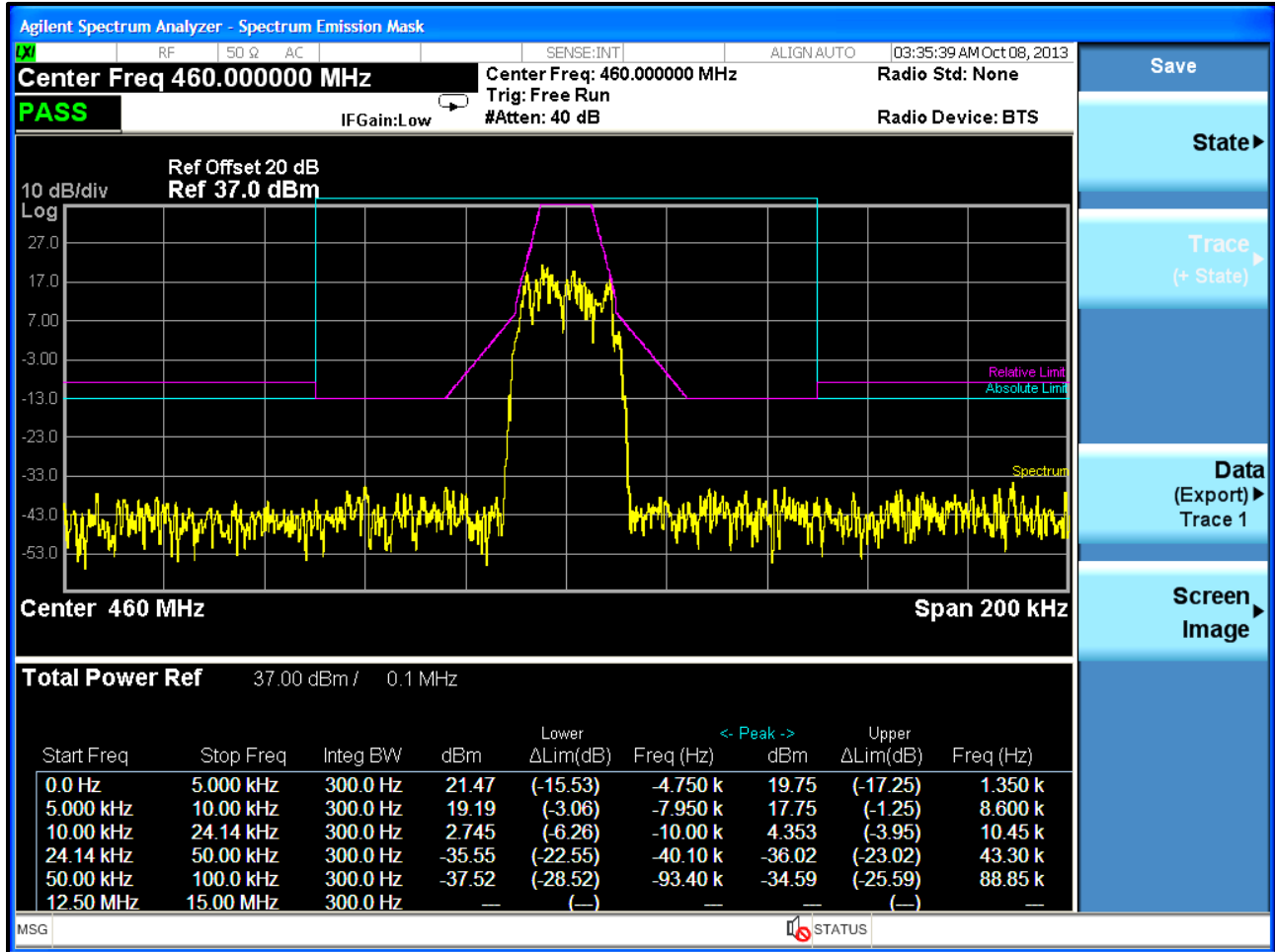

**Plot 7-12: Occupied Bandwidth – 470.0 MHz; Mask C; 25 kHz Channel Spacing**

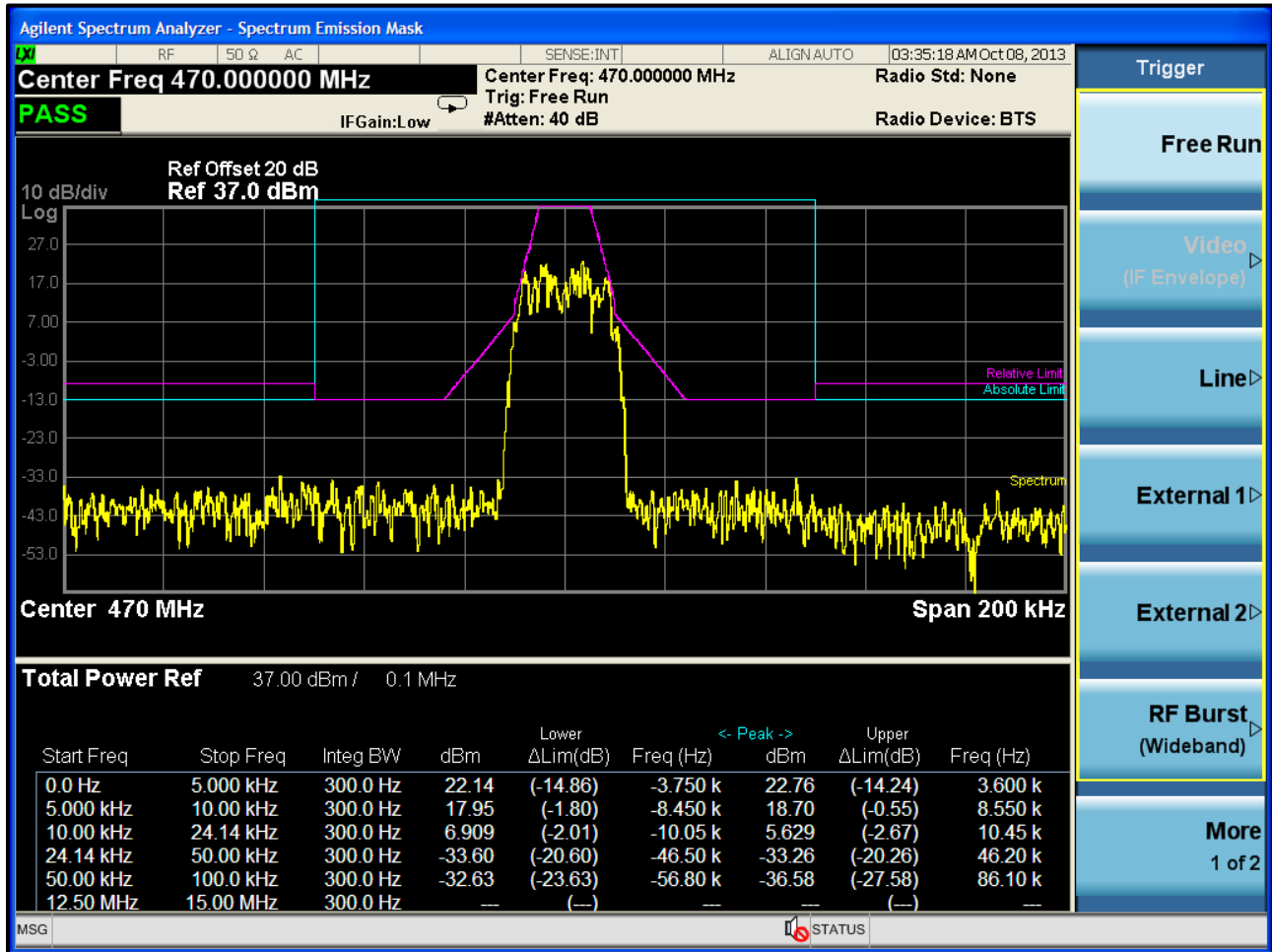

**Table 7-1: Test Equipment Used For Testing Occupied Bandwidth**

RTL Asset #	Manufacturer	Model	Part Type	Serial Number	Calibration Due Date
901583	Agilent Technologies	N9010A	EXA Signal Analyzer (10 Hz - 26.5 GHz)	MY51250846	4/16/14
901139	Weinschel Corp.	48-20-34 DC-18GHz	Attenuator, 100W 20dB	BK5859	3/25/16
900948	Weinschel Corporation	47-10-43	Attenuator DC-18 GHz 10 dB 50W	BH1487	3/18/14

**Test Personnel:**

Daniel Baltzell  
 EMC Test Engineer

Signature

October 7-8, 2013  
 Dates of Test

## 8 FCC Part 2.1055, 90.213: Frequency Stability; IC RSS-119 5.3

### 8.1 Test Procedure

ANSI/TIA-603-C-2004, section 2.2.2.

The carrier frequency stability is the ability of the transmitter to maintain an assigned carrier frequency.

The EUT was evaluated over the temperature range -30°C to +60°C.

The temperature was initially set to -30°C and a 2-hour period was observed for stabilization of the EUT. The EUT was then operated in standby mode for 15 minutes before proceeding. The frequency stability was measured within one minute after application of primary power to the transmitter. The temperature was raised at intervals of 10°C through the range. A ½ hour period was observed to stabilize the EUT at each measurement step, and the frequency stability was measured within one minute after application of primary power to the transmitter. Additionally, the power supply voltage of the EUT was varied +/-15% nominal input voltage.

Limit for frequency block 400–470 MHz for Base Station: 1.5 ppm

The worst case test data are shown below in Table 8-1 and Table 8-2.

### 8.2 Test Data

#### 8.2.1 Temperature Frequency Stability

**Table 8-1: Temperature Frequency Stability – 418 MHz**

Temperature (°C)	Measured Frequency (Hz)	ppm
-30	417.999586	-0.99
-20	417.999591	-0.98
-10	417.999751	-0.60
0	417.999899	-0.24
10	418.000021	0.05
20 (reference)	418.000000	0.00
30	417.999843	-0.38
40	417.999883	-0.28
50	417.999877	-0.29
60	417.999879	-0.29



**Table 8-2: Temperature Frequency Stability – 460 MHz**

Temperature (°C)	Measured Frequency (Hz)	ppm
-30	459.999537	-1.01
-20	459.999554	-0.97
-10	459.999714	-0.62
0	459.999893	-0.23
10	460.000019	0.04
20 (reference)	460.000000	0.00
30	459.999813	-0.41
40	459.999870	-0.28
50	459.999862	-0.30
60	459.999877	-0.27

**8.2.2 Frequency Stability/Voltage Variation**

**Table 8-3: Frequency Stability/Voltage Variation – 418 MHz**

Voltage (VDC)	Measured Frequency (Hz)	ppm
10.0	418.000023	0.06
11.5	418.000022	0.05
20.0	418.000000	0.00
25.5	418.000024	0.06
30.0	418.000024	0.06

**Table 8-4: Frequency Stability/Voltage Variation – 460 MHz**

Voltage (VDC)	Measured Frequency (Hz)	ppm
10.0	460.000600	1.30
11.5	460.000600	1.30
20.0	460.000000	0.00
25.5	460.000607	1.32
30.0	460.000617	1.34

**Table 8-5: Test Equipment Used For Testing Frequency Stability**

RTL Asset #	Manufacturer	Model	Part Type	Serial Number	Calibration Due Date
900946	Tenney Engineering, Inc.	TH65	Temperature Chamber with Humidity	11380	1/13/14
901300	Agilent Technologies	53131A	Frequency Counter	MY40001345	7/18/14
900948	Weinschel Corporation	47-10-43	Attenuator DC-18 GHz 10 dB 50W	BH1487	3/18/14
901350	Meterman	33XR	Multimeter	040402802	3/20/15
901594	Insulated Wire Inc.	KPS-1503-360-KPR	SMK RF Cables 36"	NA	8/27/14

**Test Personnel:**

Daniel Baltzell  
EMC Test Engineer



Signature

October 5, 2013  
Date of Test

## 9 FCC Rules and Regulations Part 90.214; RSS-119 5.9: Transient Frequency Response

### 9.1 Test Procedure

ANSI/TIA-603-C-2004 Section 2.2.3

Test Exceptions: The transmitter was unable to operate in an unmodulated mode and the plots show between t2 and t3 this unmodulated condition; this is why the plots deviate greater than when a normal unmodulated carrier is used.

When a transmitter is turned on, the radio frequency may take some time to stabilize. During this initial period, the frequency error or frequency difference (i.e. between the instantaneous and the steady state frequencies) shall not exceed the limits as follows.

Transient Frequency Behavior Channel Spacing (kHz)	Time Intervals	Maximum Frequency Difference (kHz)	Transient Duration Limit (ms)	
			138-174 MHz	*421 - 512 MHz *(406.1 IC)
25	t1	±25	5	10
	t2	±12.5	20	25
	t3	±25	5	10
12.5	t1	±12.5	5	10
	t2	±6.25	20	25
	t3	±12.5	5	10
6.25	t1	±6.25	5	10
	t2	±3.125	20	25
	t3	±6.25	5	10

Plot 9-1: Transient Frequency Behavior – On Time; 406.1 MHz; 12.5 kHz Channel Spacing

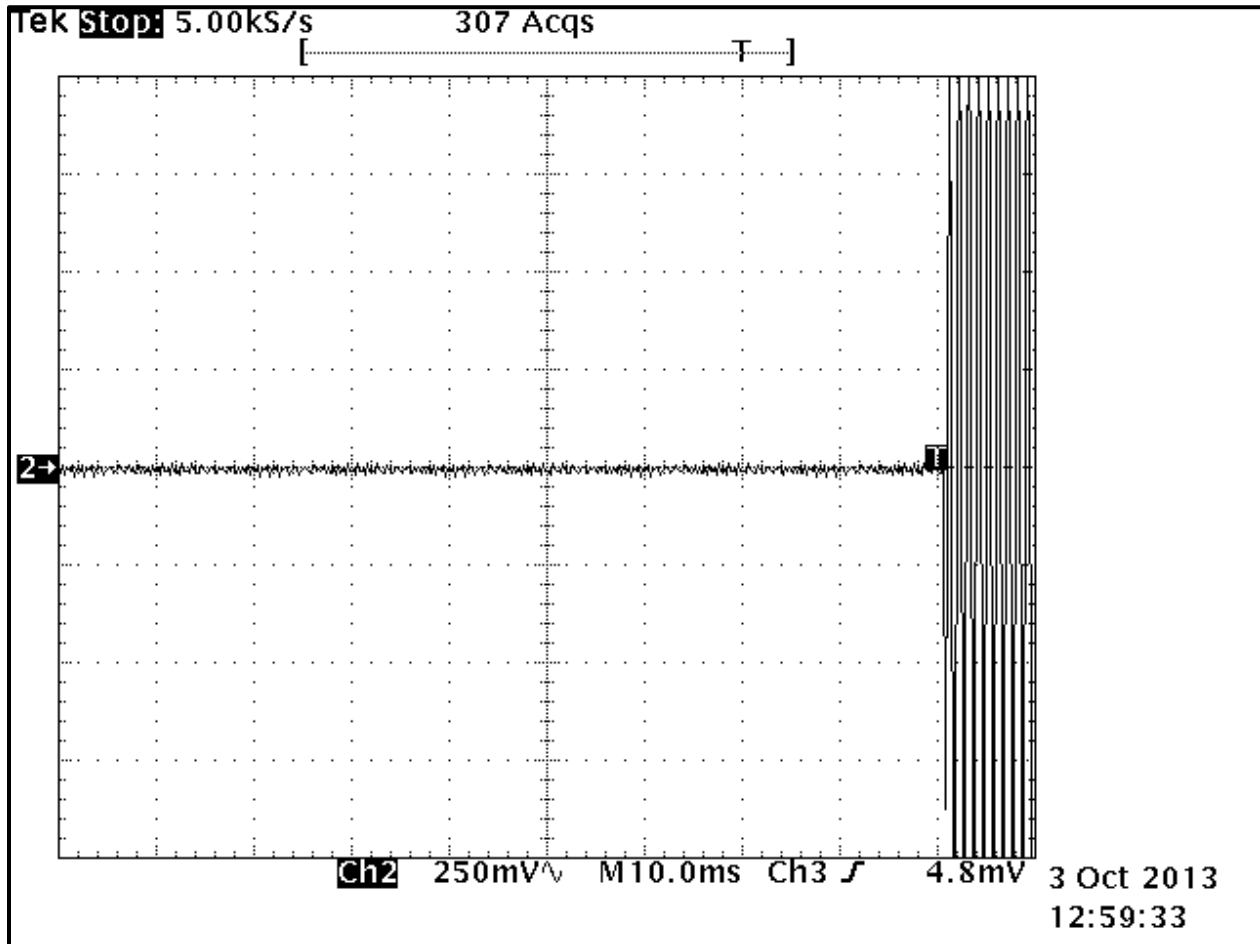

Plot 9-2: Transient Frequency Behavior – On Time; 418.0 MHz; 12.5 kHz Channel Spacing

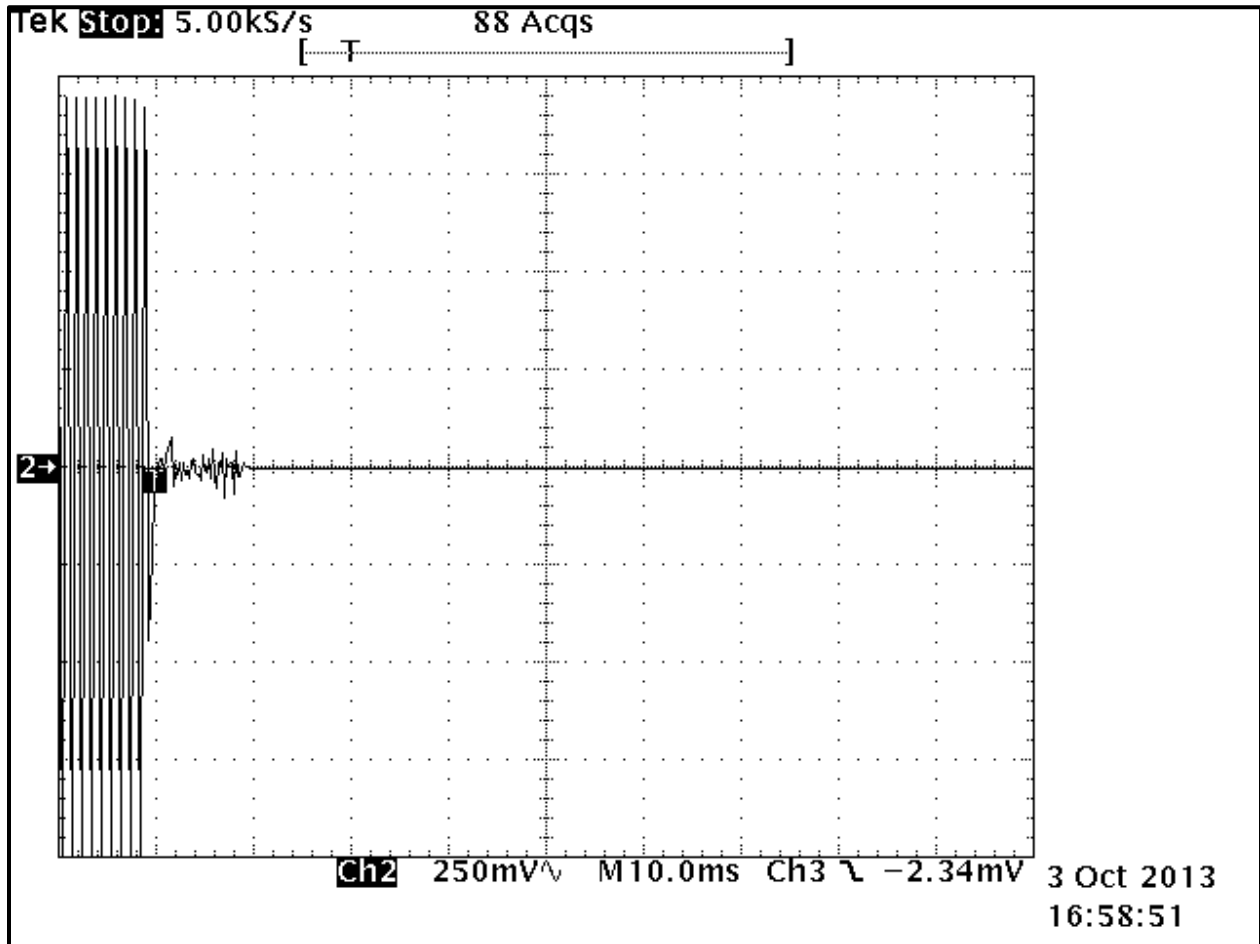

**Plot 9-3: Transient Frequency Behavior – On Time; 430.0 MHz; 12.5 kHz Channel Spacing**

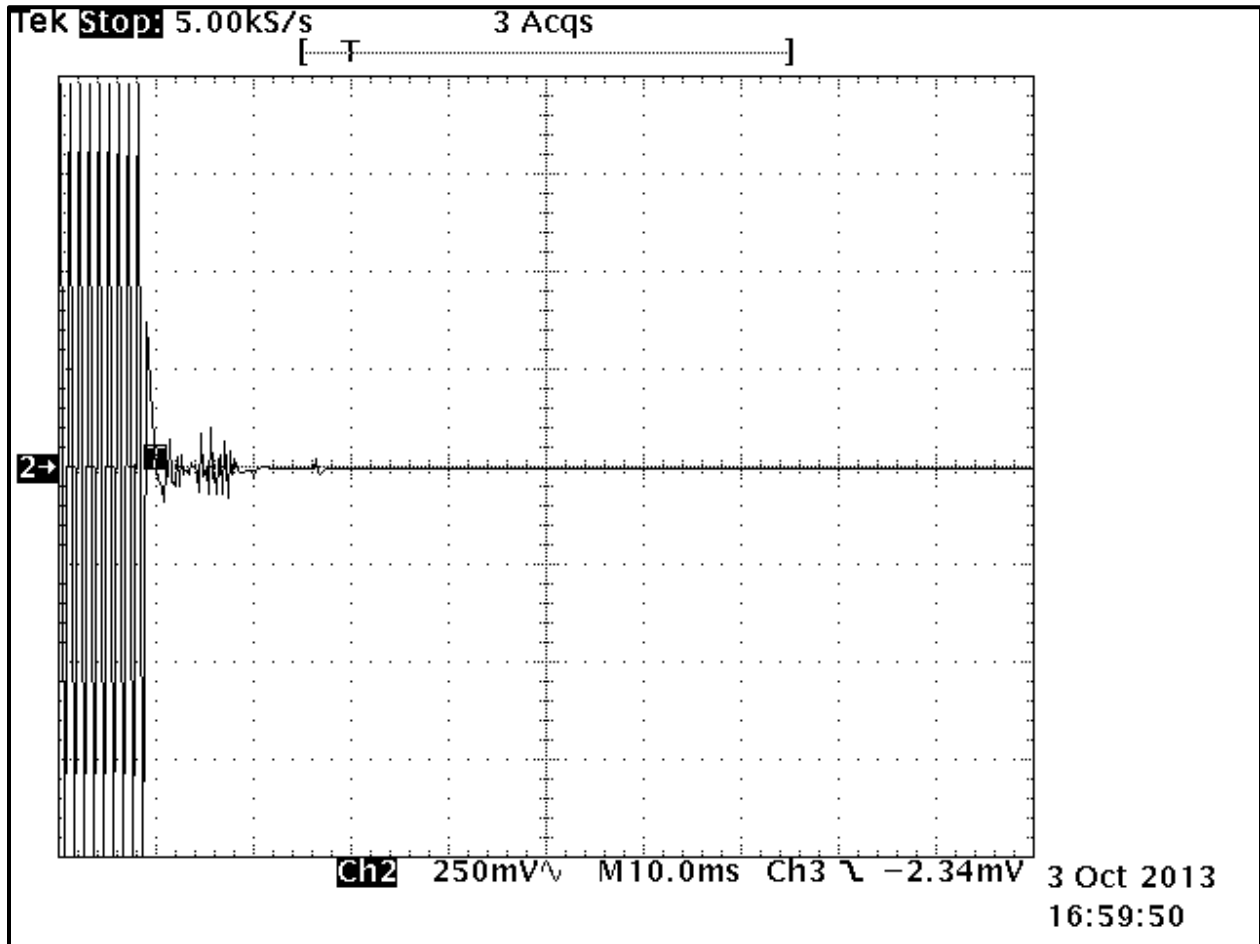

Plot 9-4: Transient Frequency Behavior – On Time; 450.0 MHz; 12.5 kHz Channel Spacing

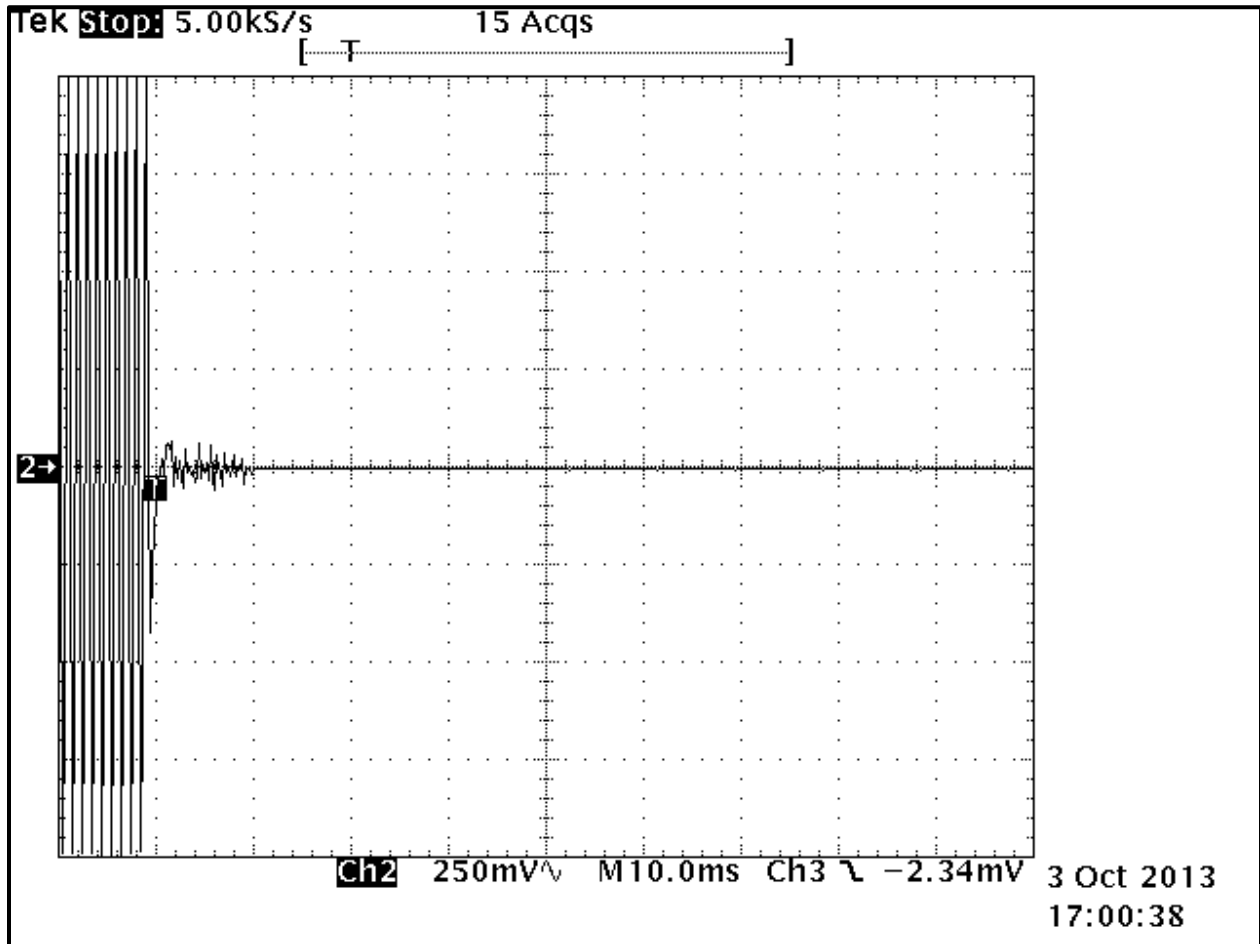

Plot 9-5: Transient Frequency Behavior – On Time; 460.0 MHz; 12.5 kHz Channel Spacing

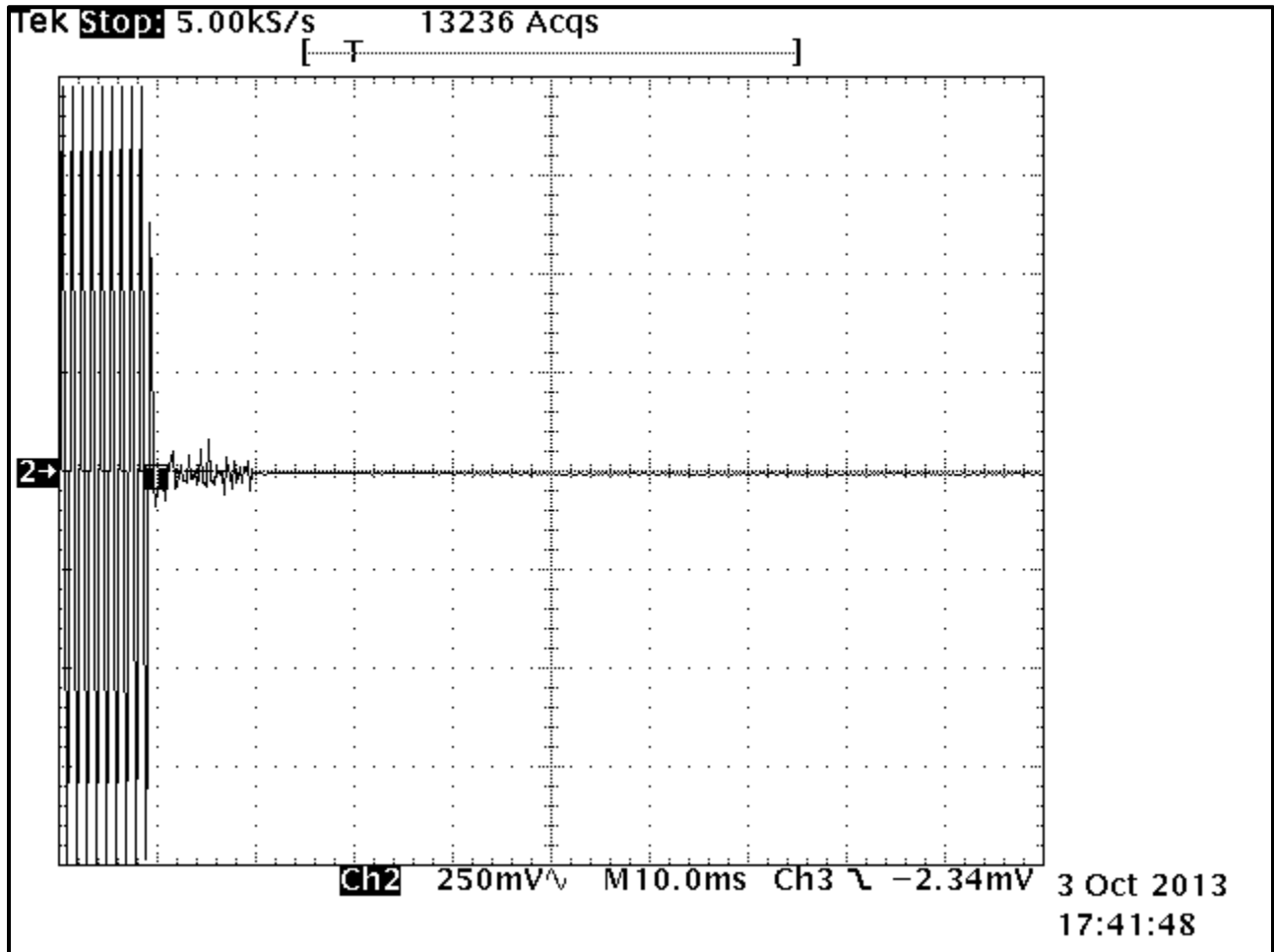



Plot 9-6: Transient Frequency Behavior – On Time; 470.0 MHz; 12.5 kHz Channel Spacing

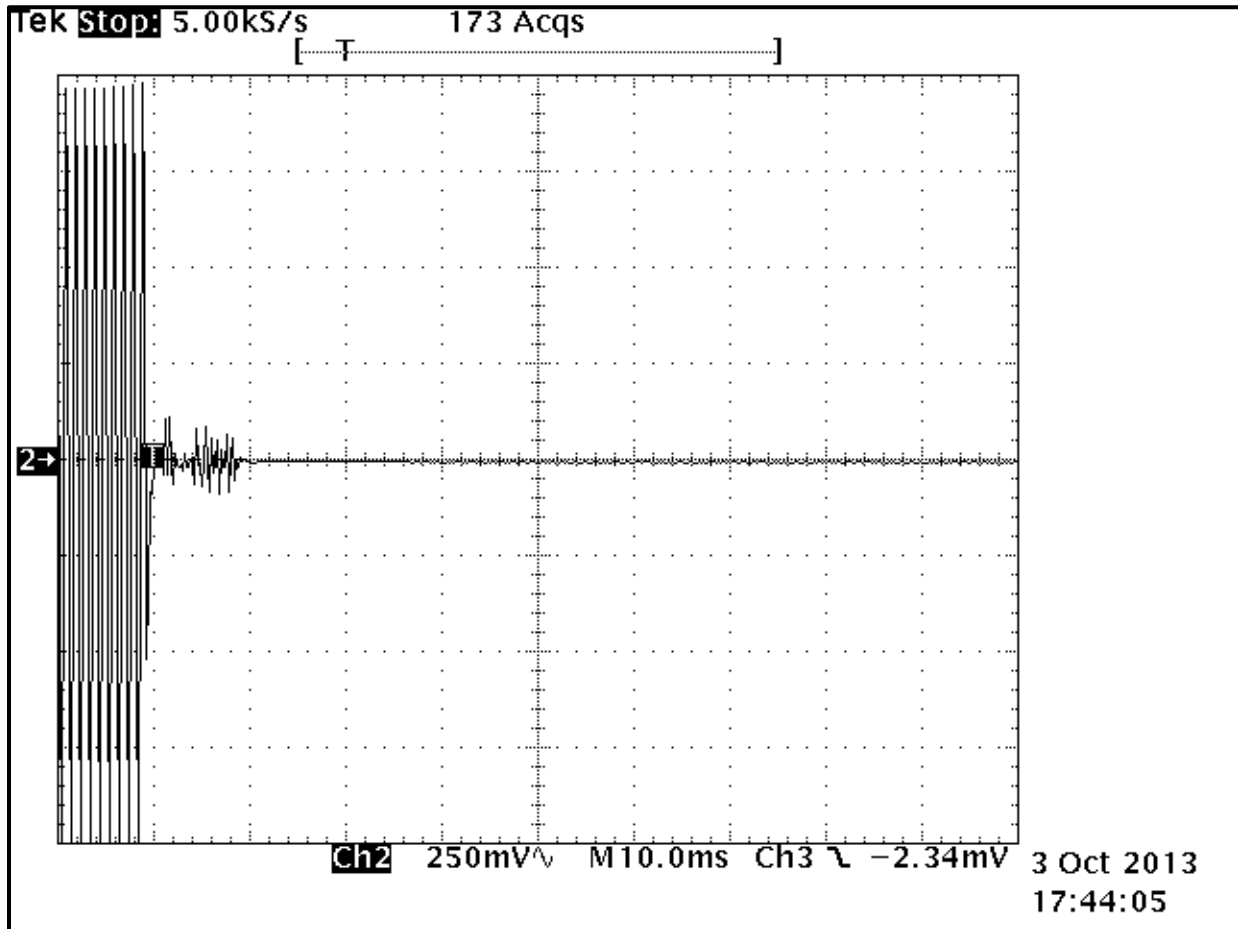

Plot 9-7: Transient Frequency Behavior – Off Time; 406.1 MHz; 12.5 kHz Channel Spacing

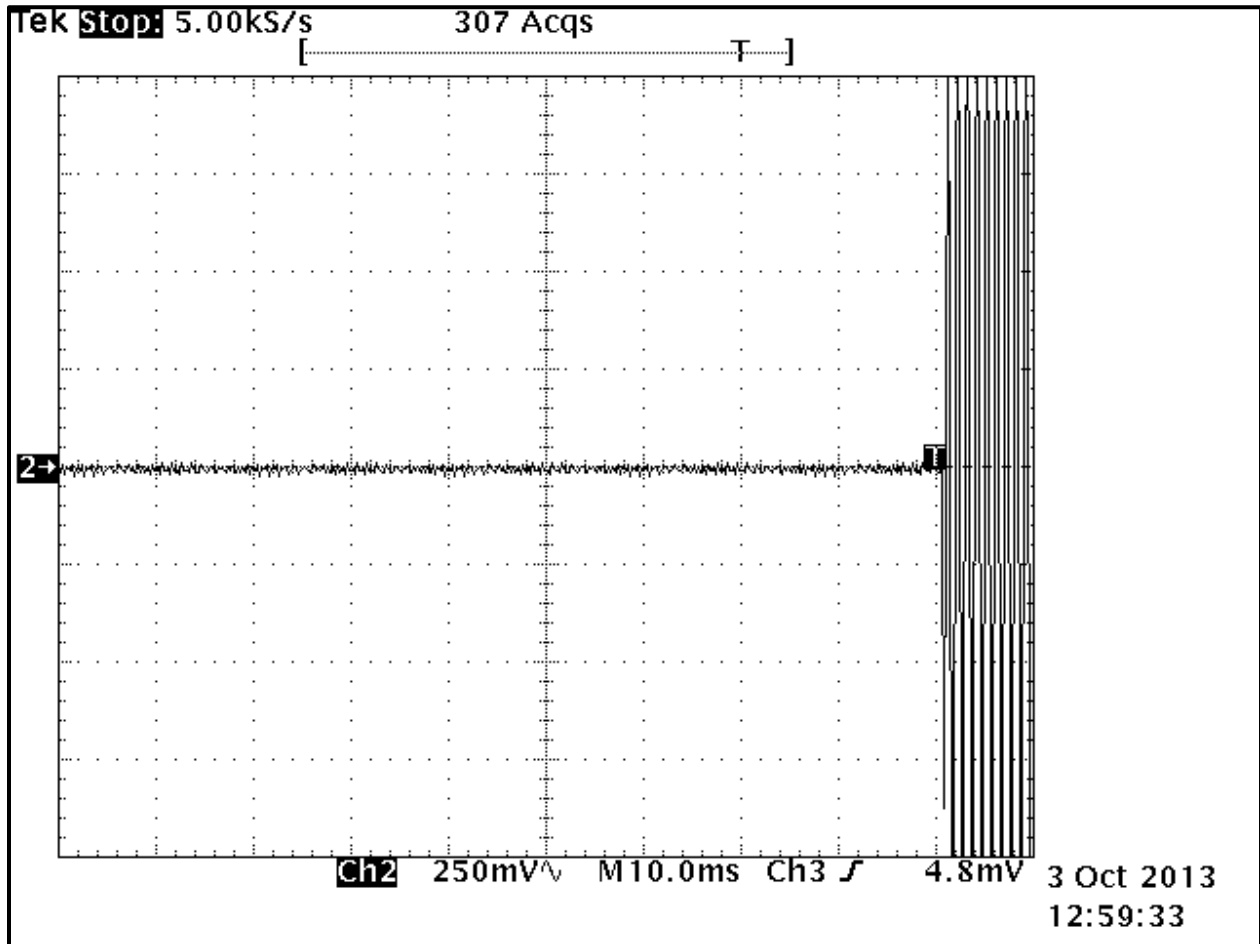

**Plot 9-8: Transient Frequency Behavior – Off Time; 418.0 MHz; 12.5 kHz Channel Spacing**

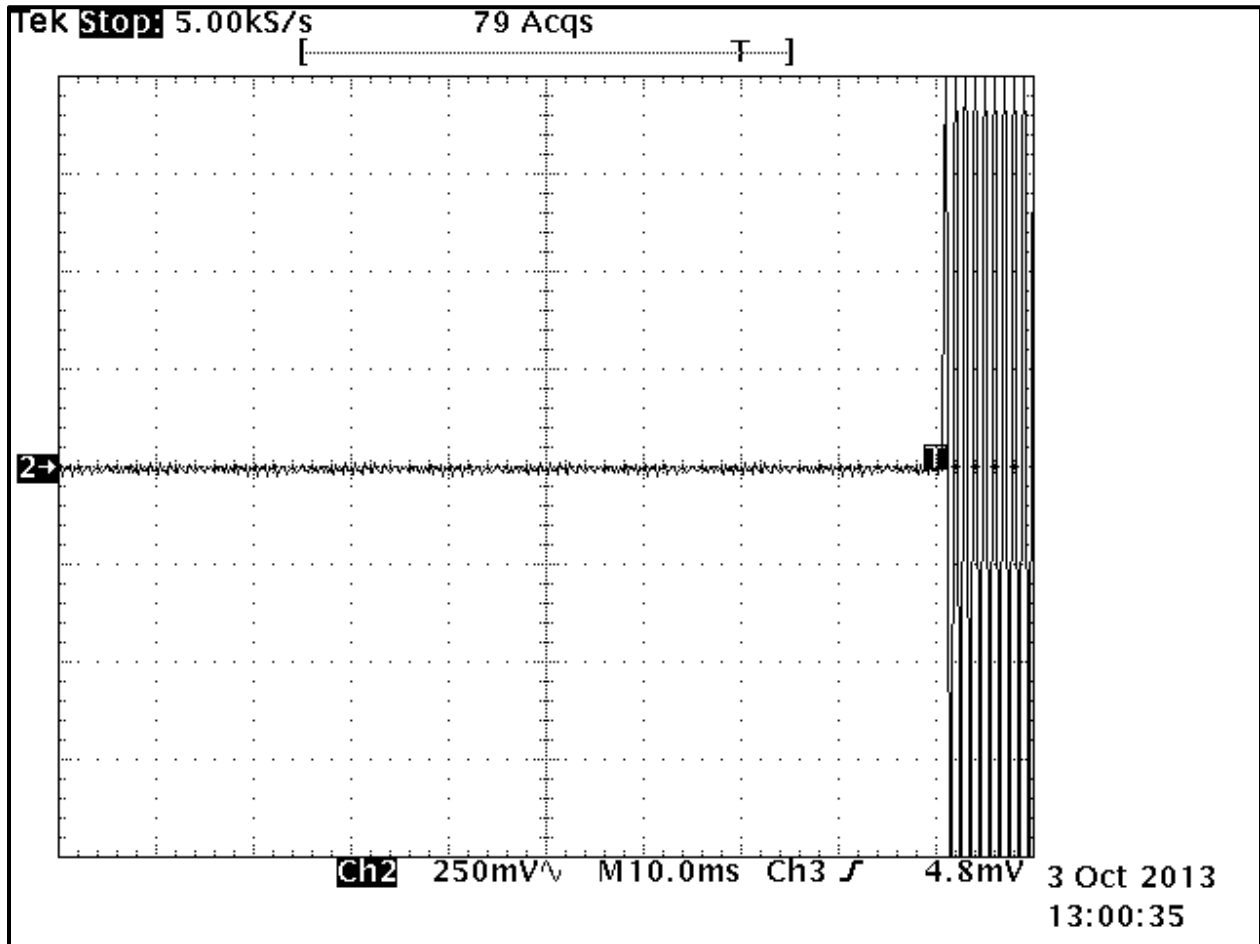

**Plot 9-9: Transient Frequency Behavior – Off Time; 430.0 MHz; 12.5 kHz Channel Spacing**

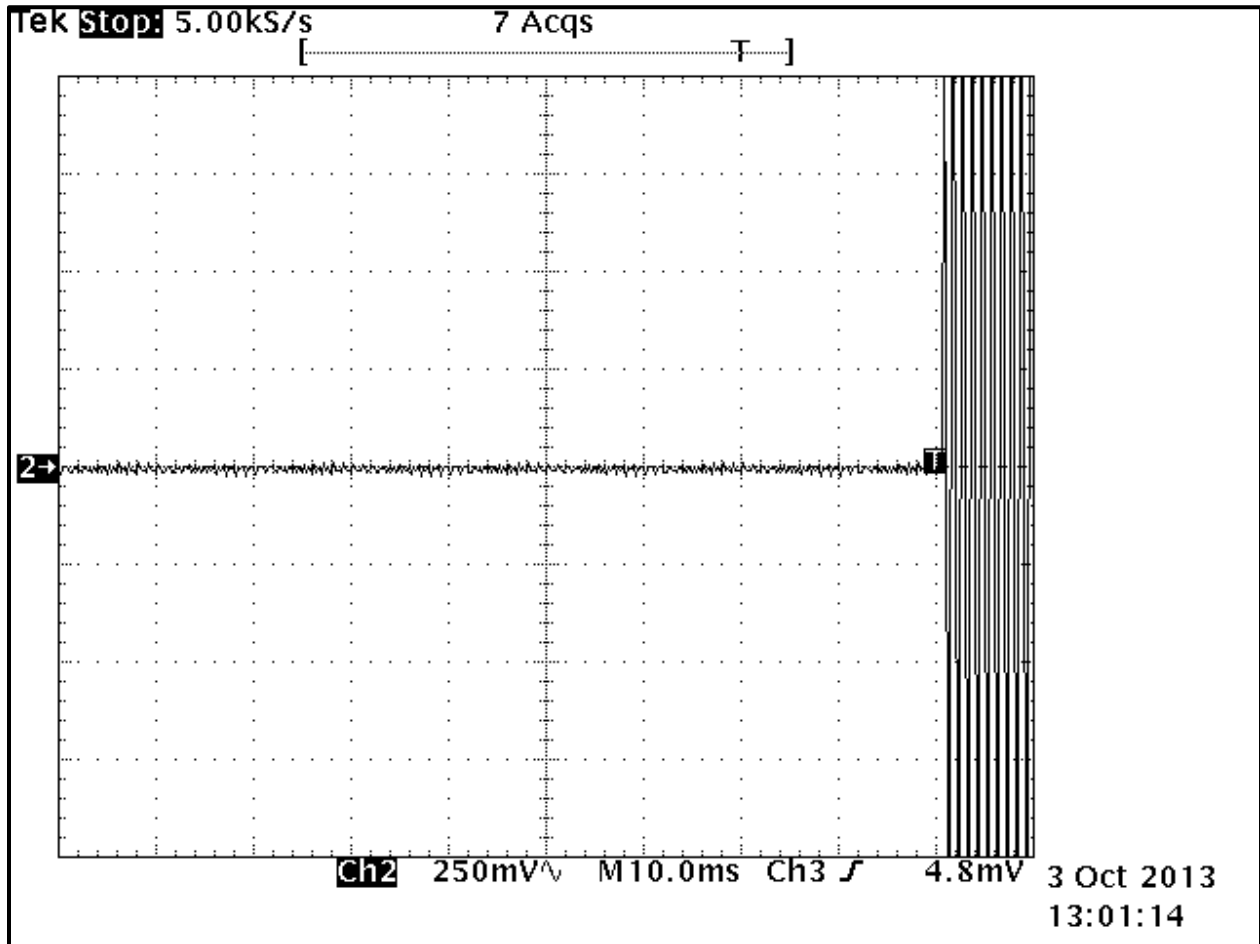

Plot 9-10: Transient Frequency Behavior – Off Time; 450.0 MHz; 12.5 kHz Channel Spacing

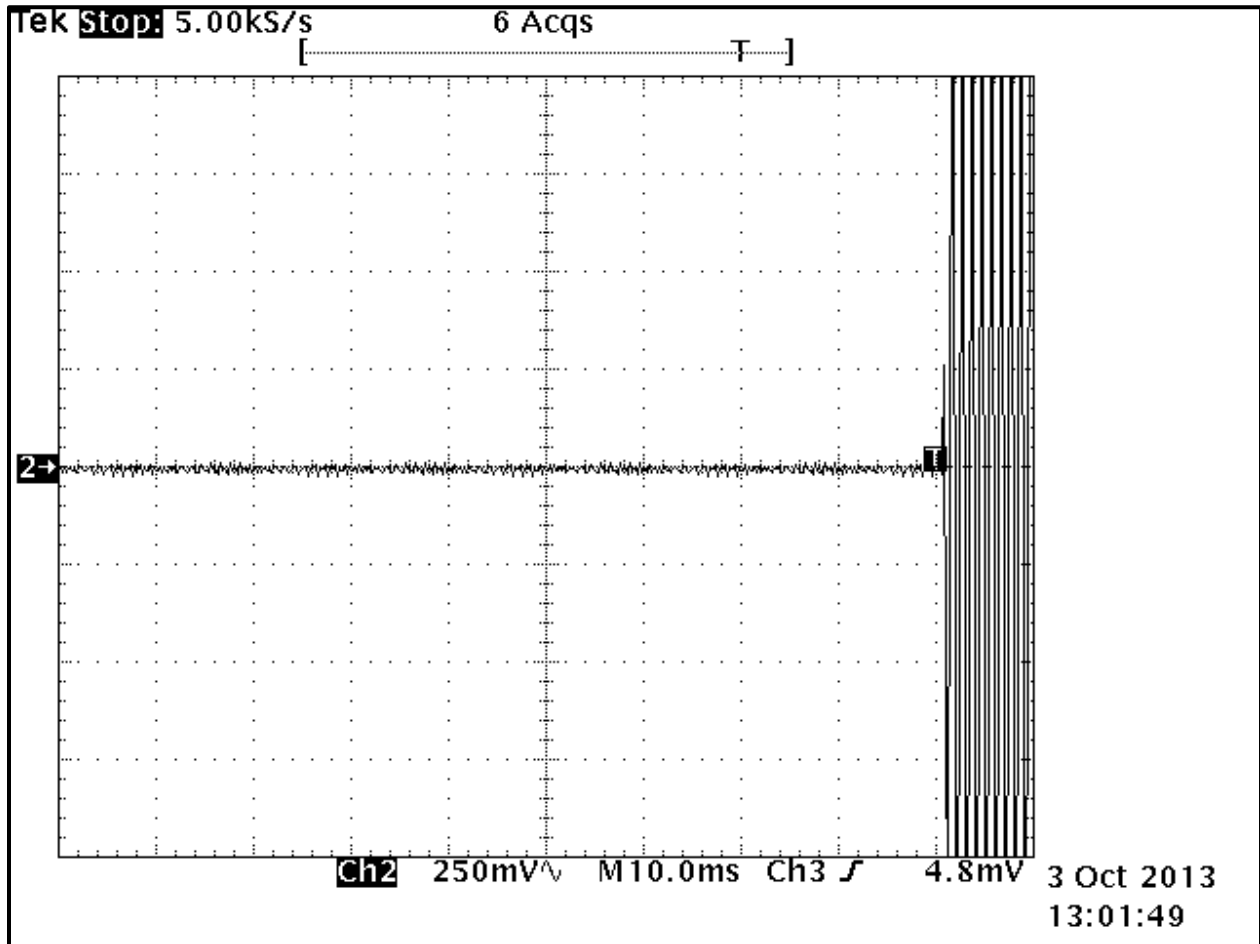

**Plot 9-11: Transient Frequency Behavior – Off Time; 460.0 MHz; 12.5 kHz Channel Spacing**

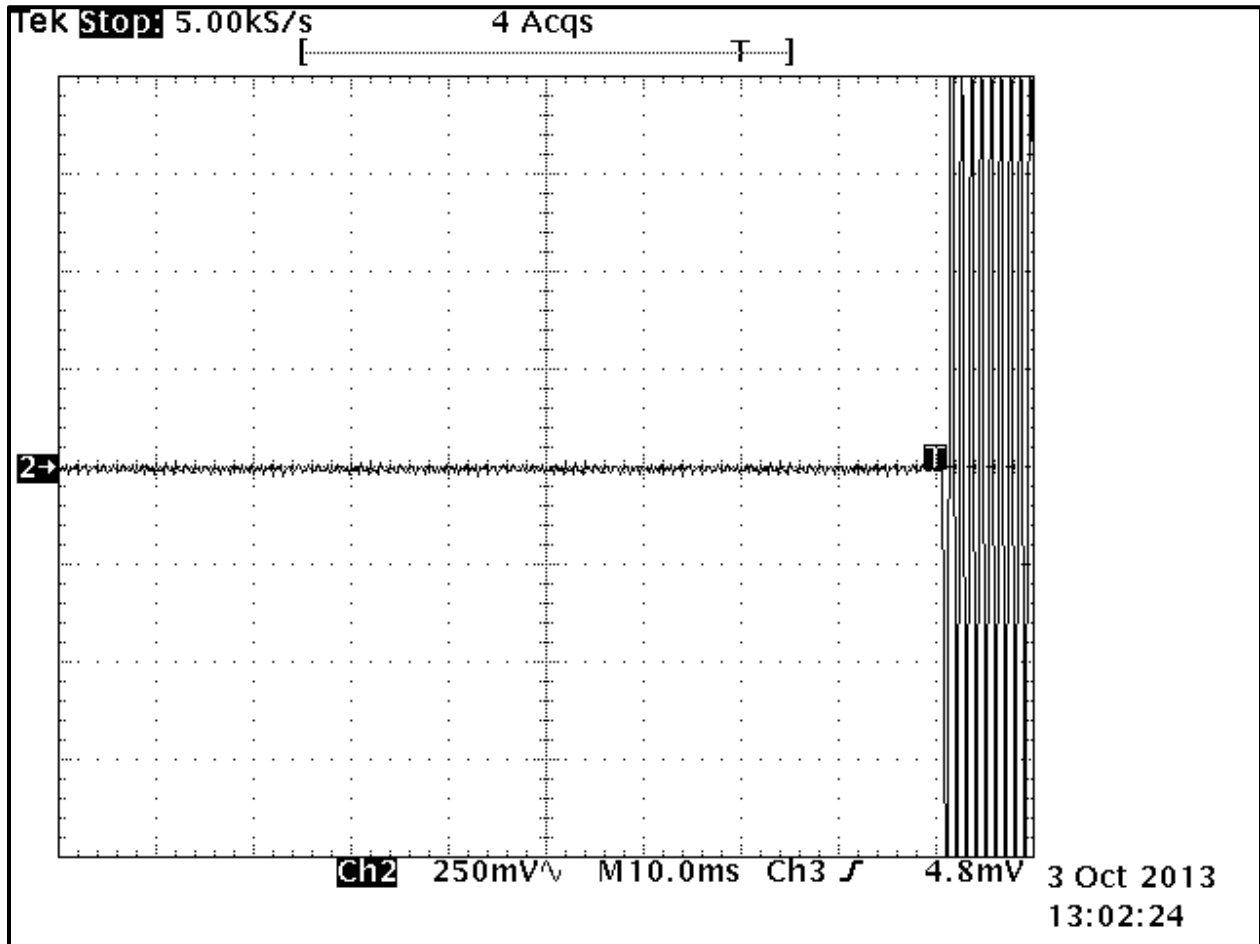

Plot 9-12: Transient Frequency Behavior – Off Time; 470.0 MHz; 12.5 kHz Channel Spacing

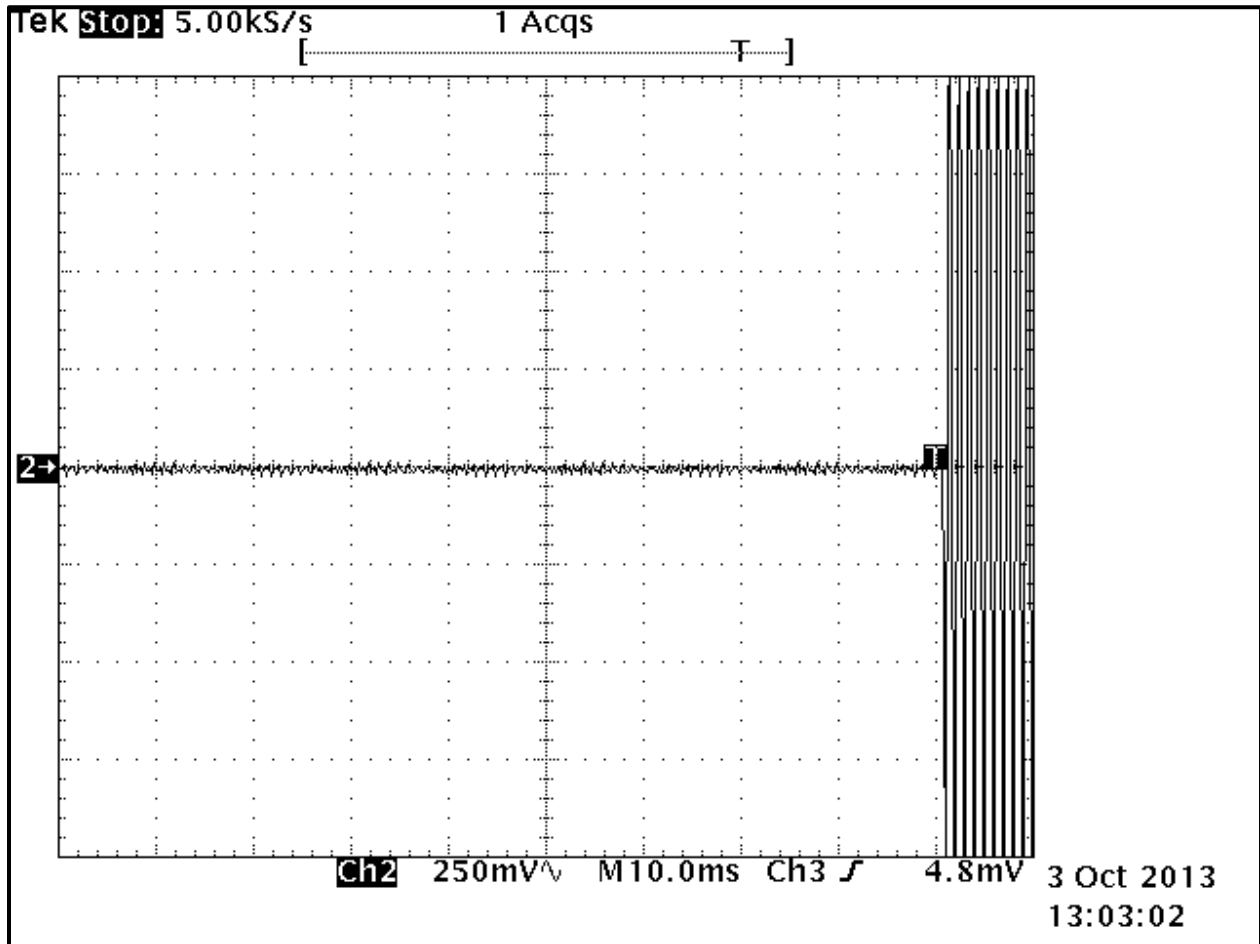

Plot 9-13: Transient Frequency Behavior – On Time; 406.1 MHz; 25 kHz Channel Spacing

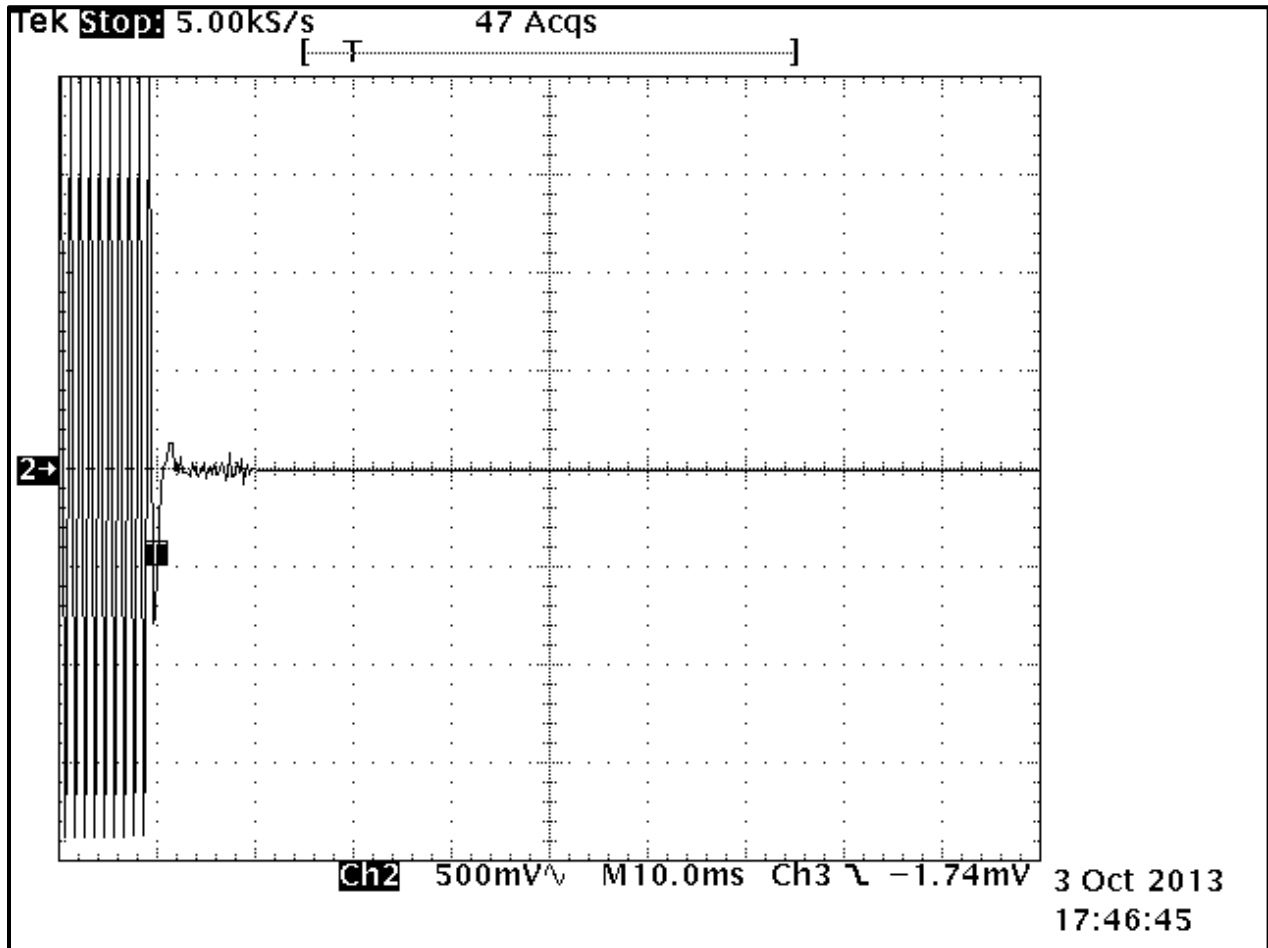



Plot 9-14: Transient Frequency Behavior – On Time; 418.0 MHz; 25 kHz Channel Spacing

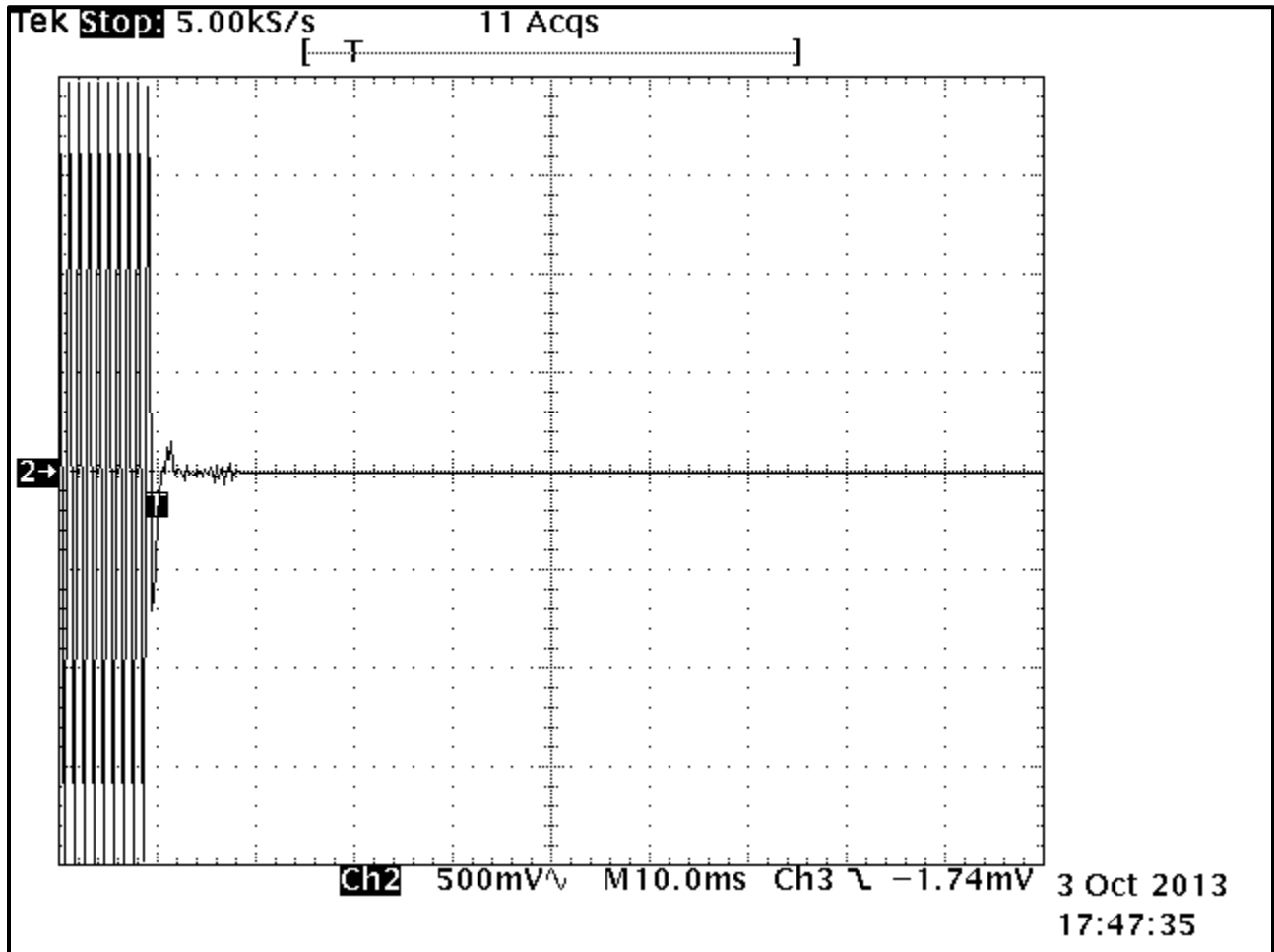

Plot 9-15: Transient Frequency Behavior – On Time; 430.0 MHz; 25 kHz Channel Spacing

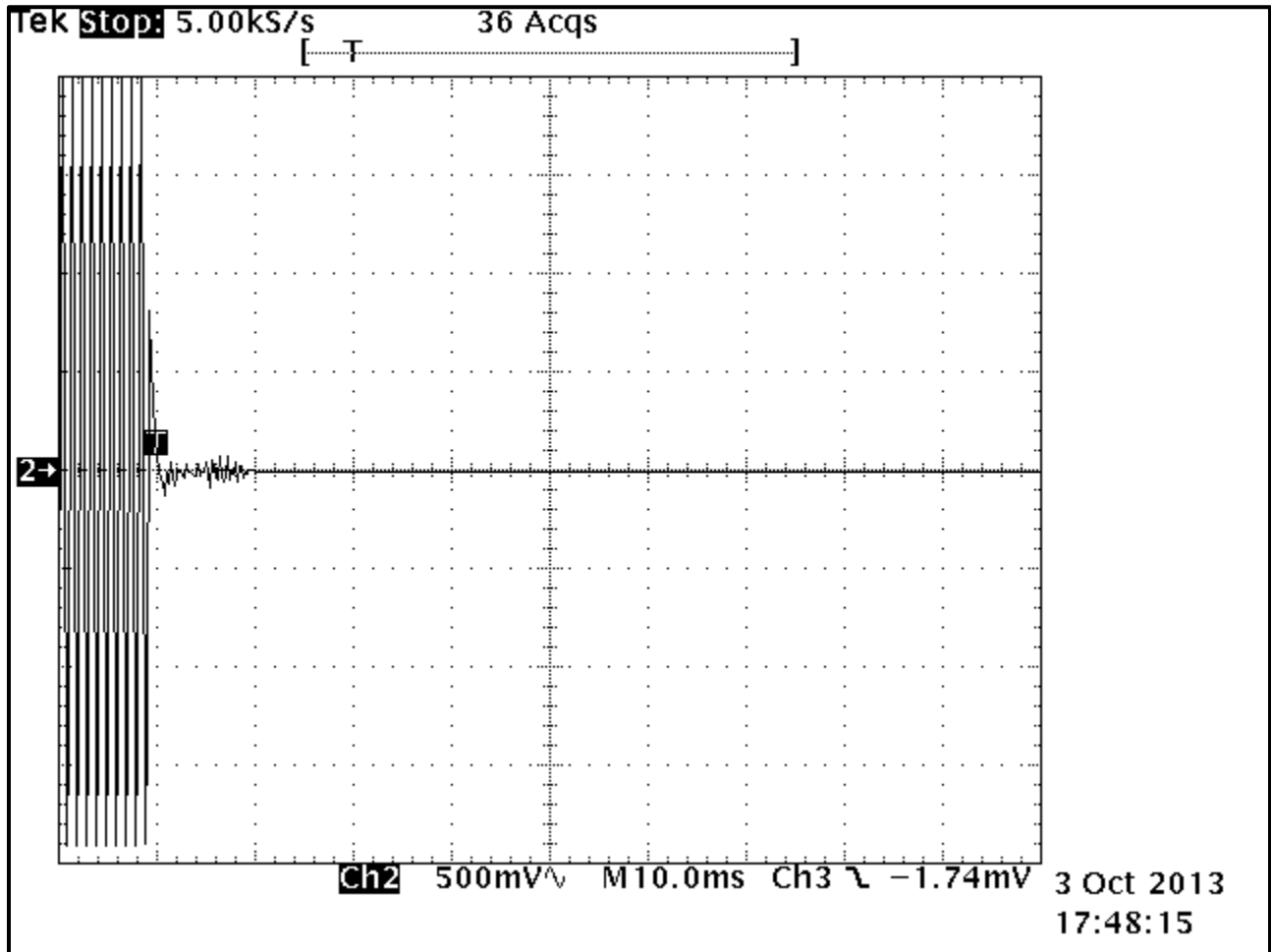

Plot 9-16: Transient Frequency Behavior – On Time; 450.0 MHz; 25 kHz Channel Spacing

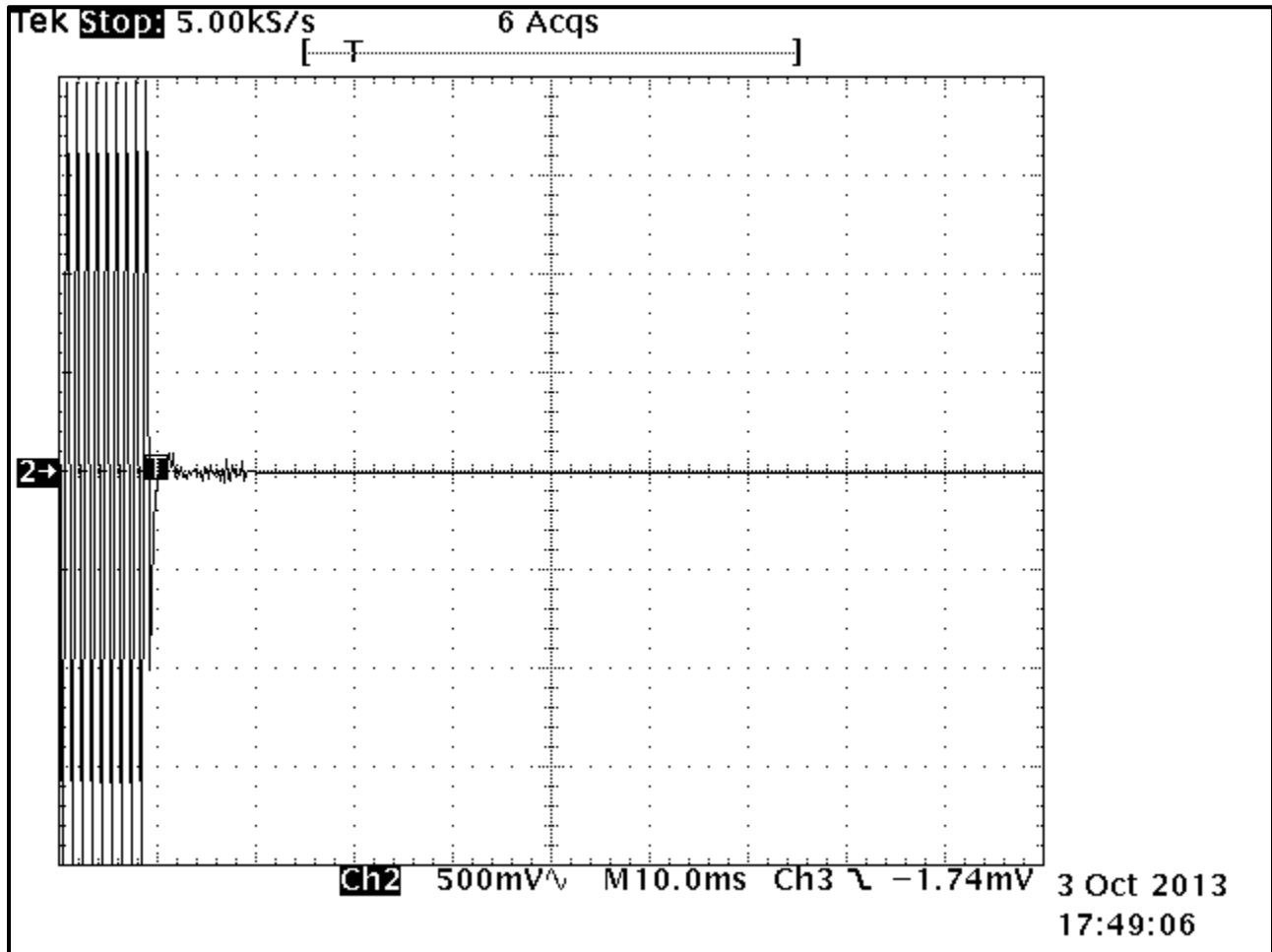

Plot 9-17: Transient Frequency Behavior – On Time; 460.0 MHz; 25 kHz Channel Spacing

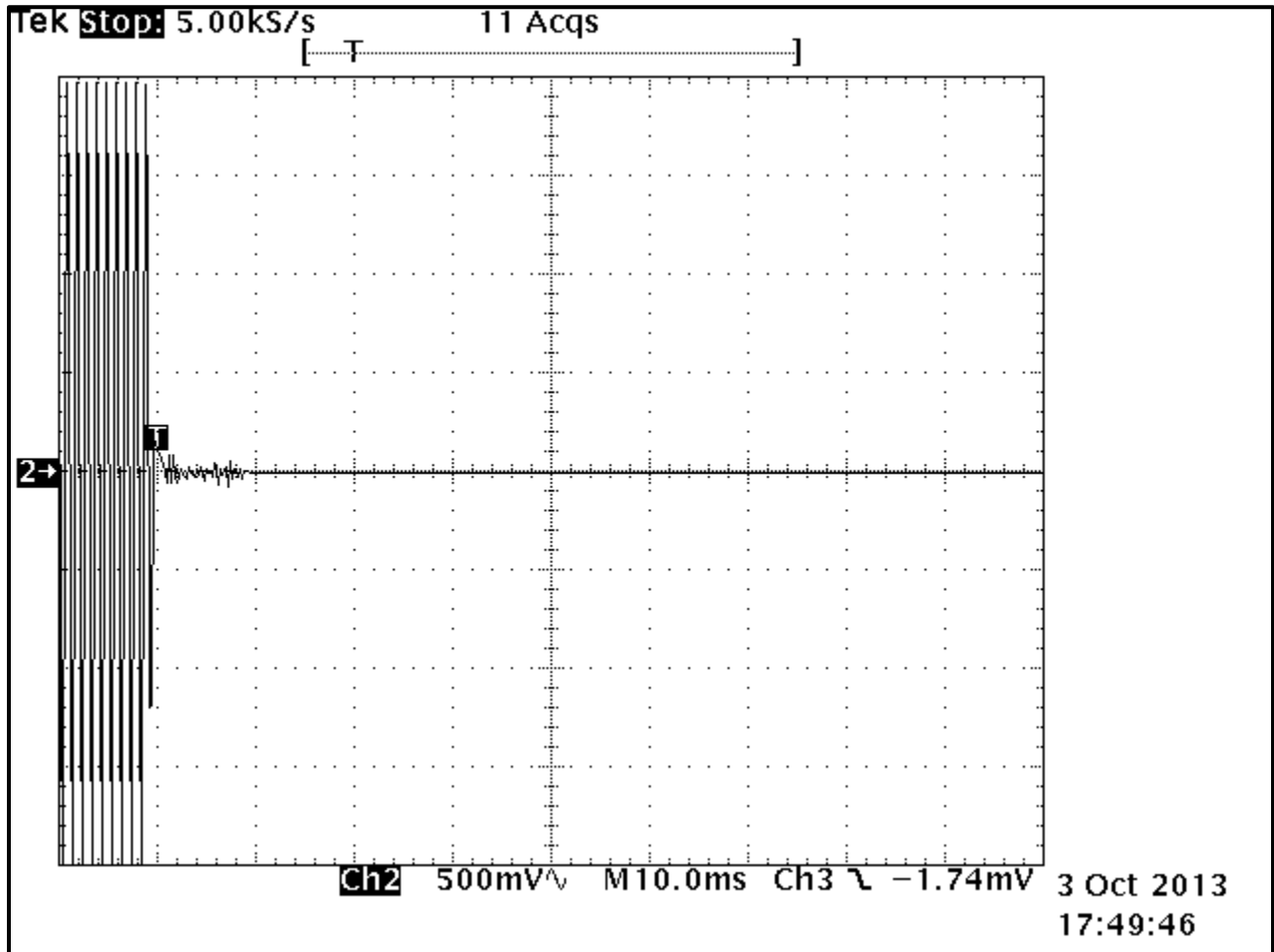

Plot 9-18: Transient Frequency Behavior – On Time; 470.0 MHz; 25 kHz Channel Spacing

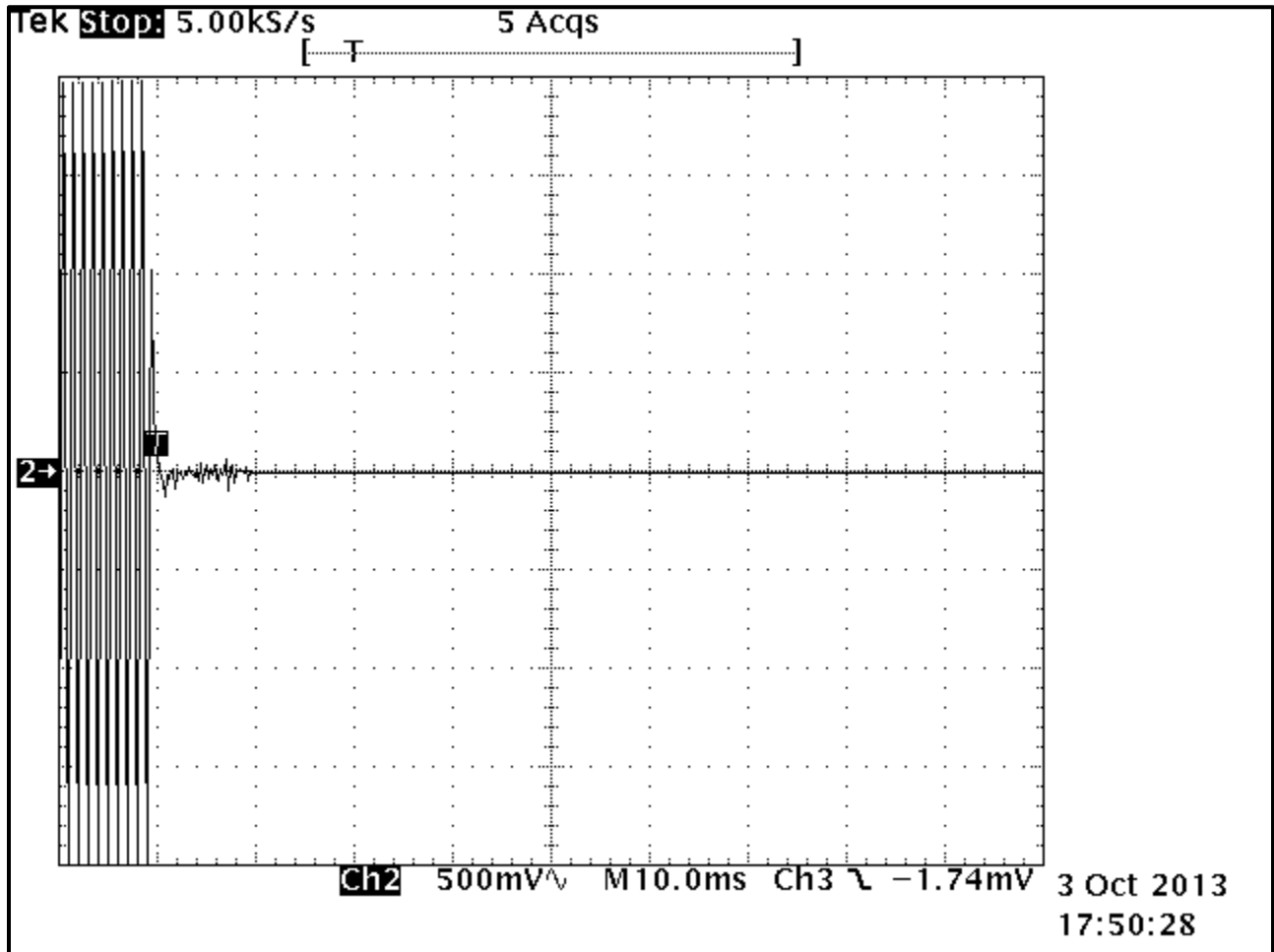

Plot 9-19: Transient Frequency Behavior – Off Time; 406.1 MHz; 25 kHz Channel Spacing

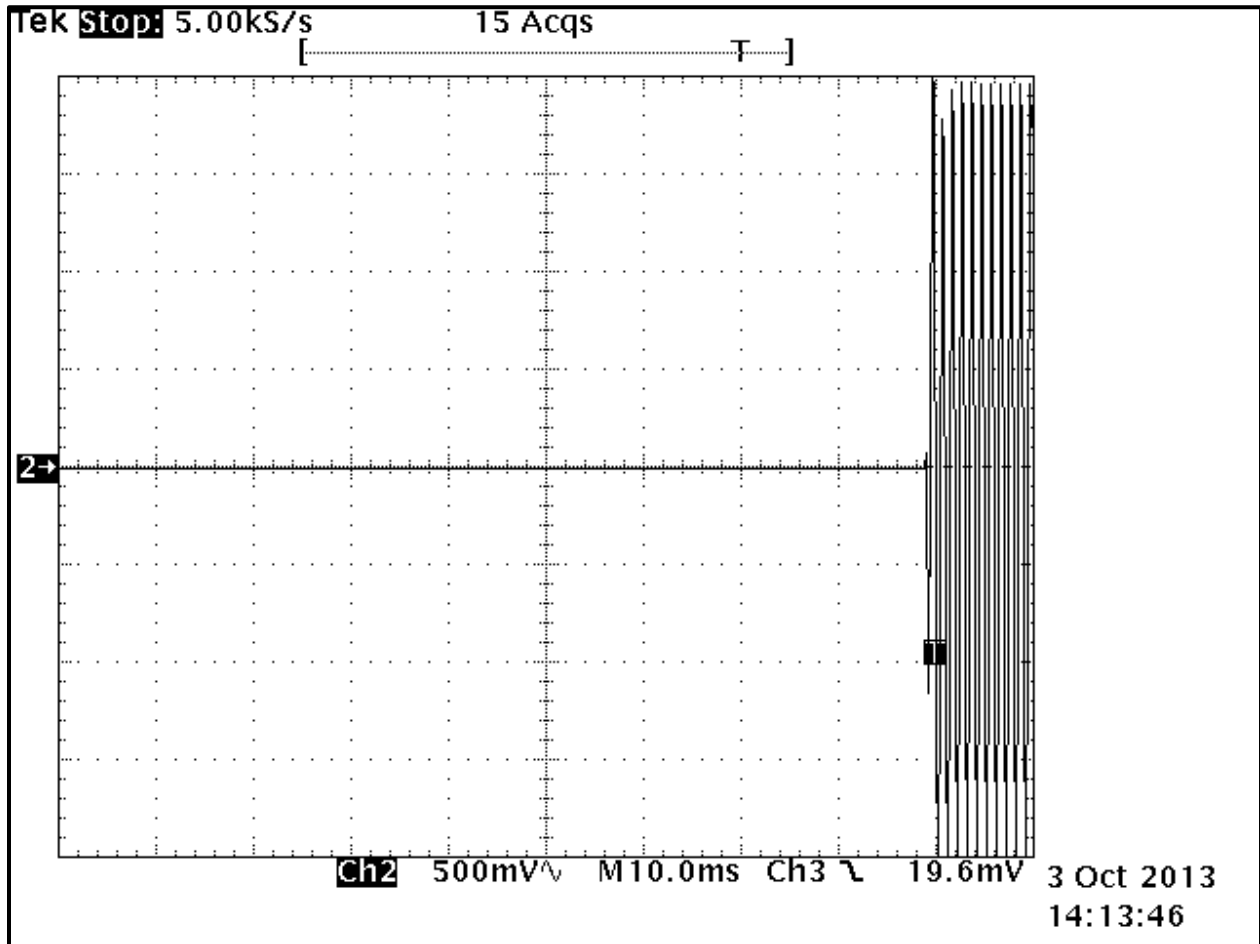

Plot 9-20: Transient Frequency Behavior – Off Time; 418.0 MHz; 25 kHz Channel Spacing

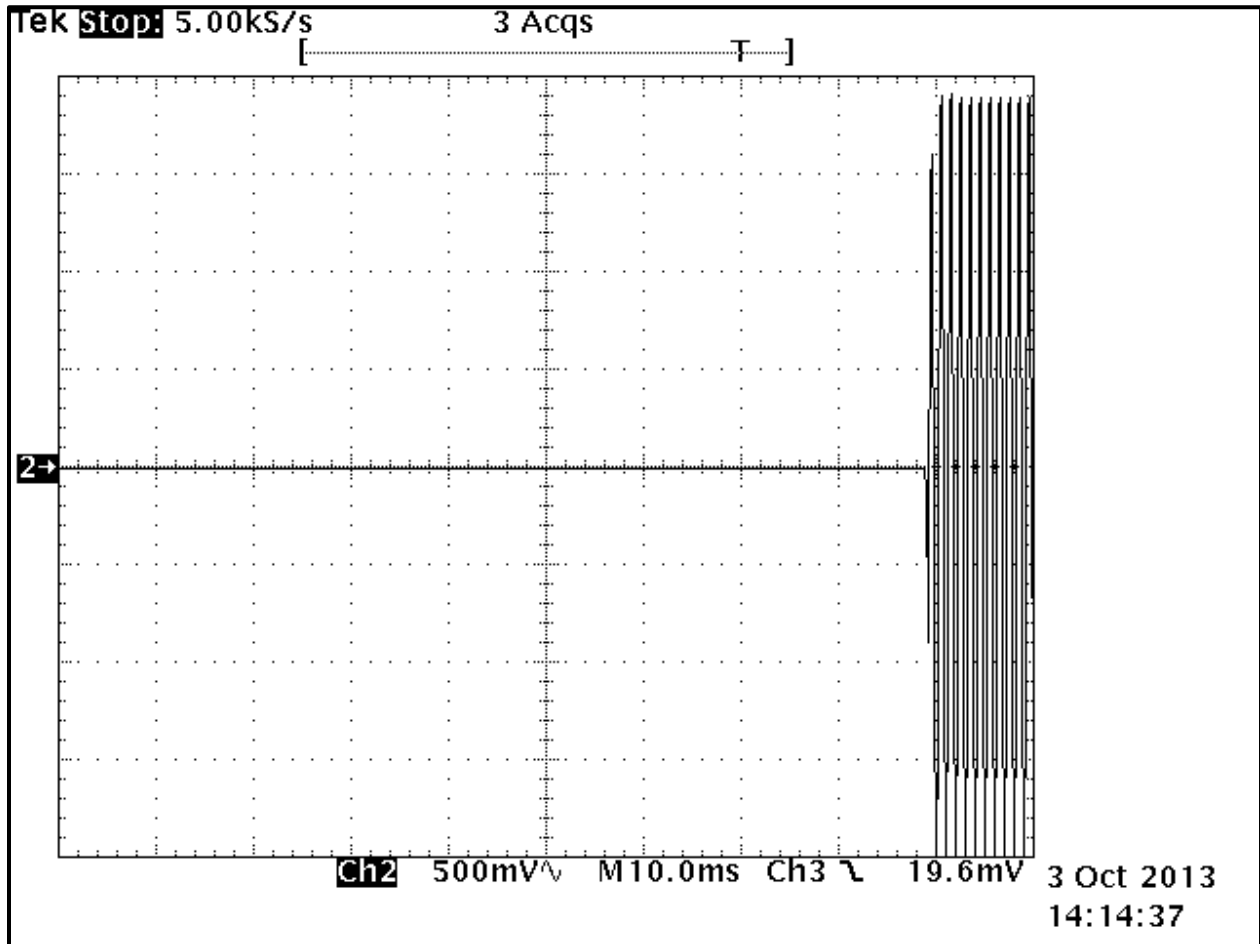

Plot 9-21: Transient Frequency Behavior – Off Time; 430.0 MHz; 25 kHz Channel Spacing

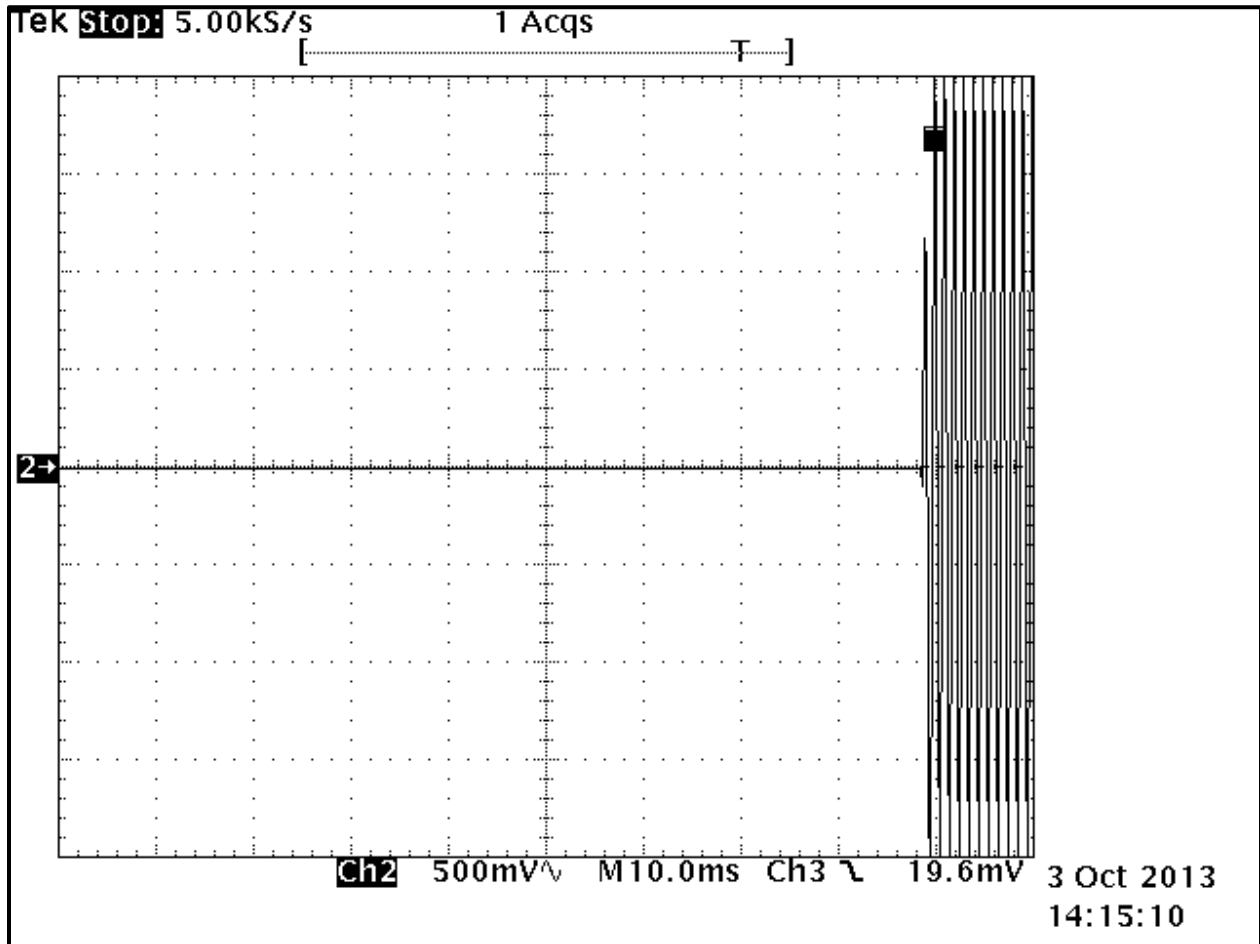



Plot 9-22: Transient Frequency Behavior – Off Time; 450.0 MHz; 25 kHz Channel Spacing

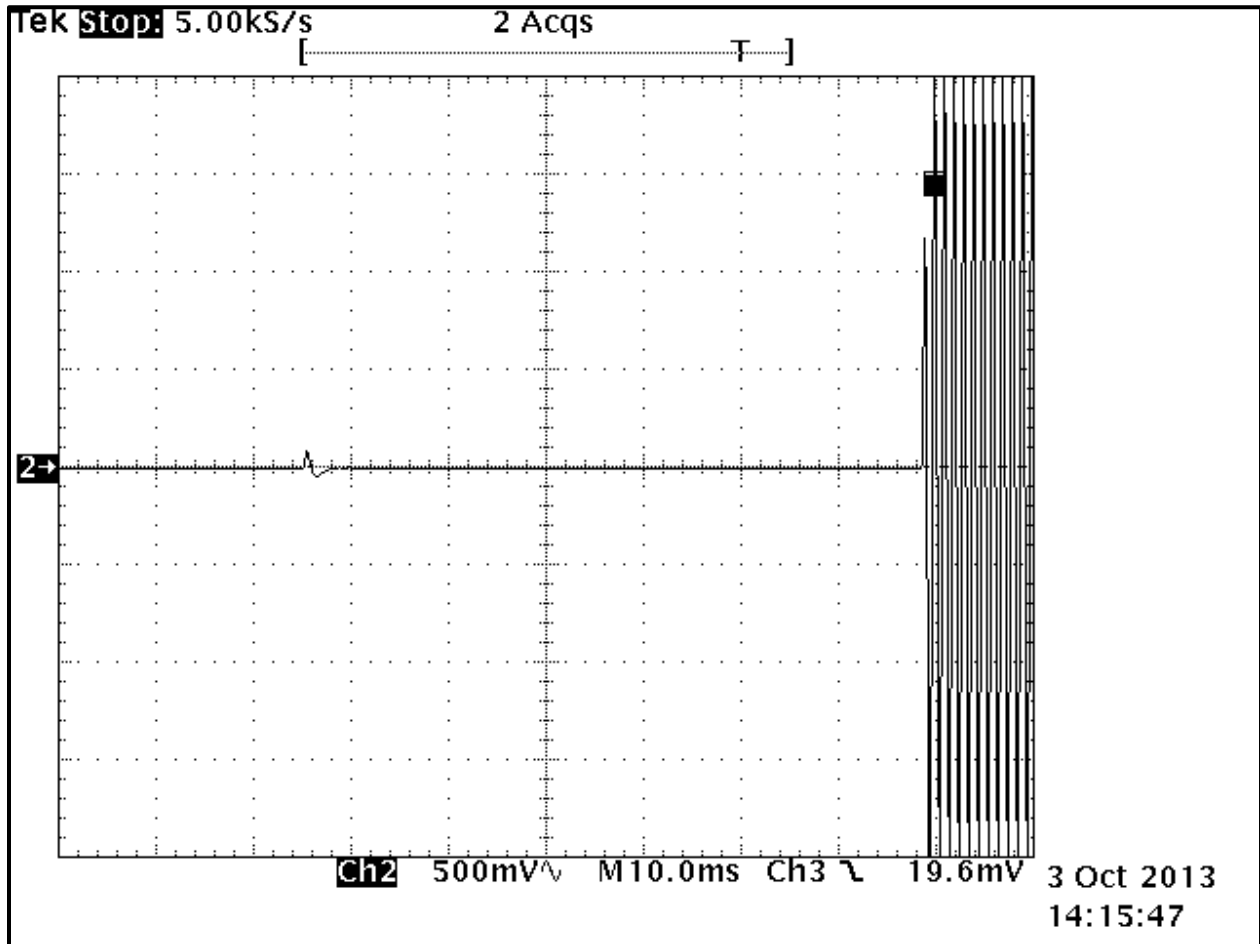

Plot 9-23: Transient Frequency Behavior – Off Time; 460.0 MHz; 25 kHz Channel Spacing

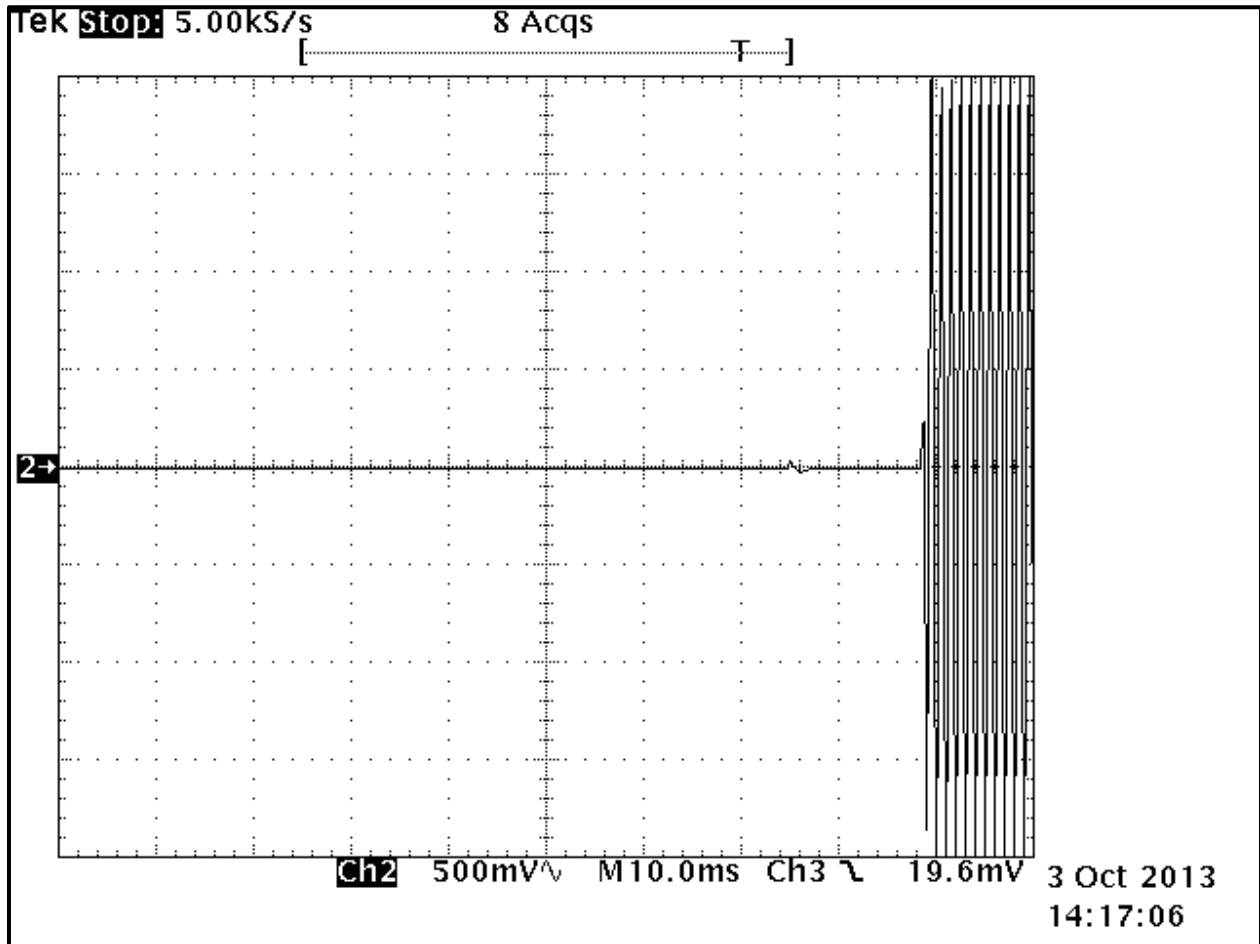

Plot 9-24: Transient Frequency Behavior – Off Time; 470.0 MHz; 25 kHz Channel Spacing

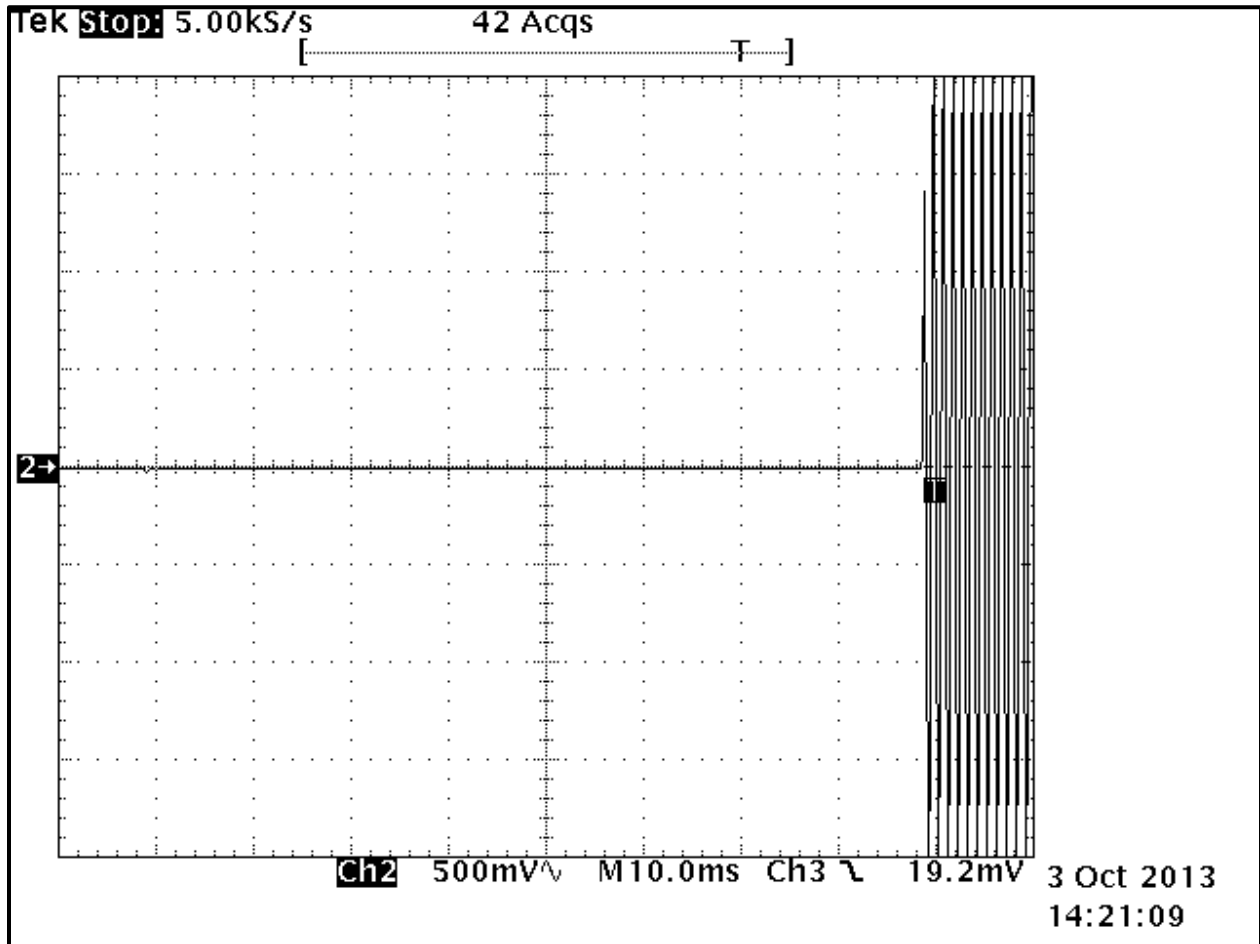

**Table 9-1: Test Equipment Used For Testing Transient Frequency Behavior**

RTL Asset #	Manufacturer	Model	Part Type	Serial Number	Calibration Due Date
901118	Hewlett Packard	8901A Opt. 002-003	Modulation Analyzer	2406A00178	4/1/15
901514	Tektronix	TDS7404B	Oscilloscope	B010161	4/20/14
900917	Hewlett Packard	8648C	Synthesized Signal Generator (9 kHz - 3200 MHz)	3537A01741	2/12/14
901337	Narda Microline	766-10	Attenuator (DC-4GHz, 10 dB, 20W)	6242	9/3/14
900948	Weinschel Corp.	47-10-43	Attenuator (DC-18GHz, 40 dB, 25W)	BH1487	3/18/14
901536	Aeroflex	48-40-34	40 dB Attenuator	CB6627	12/14/13
901511	Pasternack	PE 2003	Power Divider (10 MHz - 1 GHz)	NA	N/A
901463	Werlatone Inc.	C1795	Directional Coupler, 100W, 40 dB, 1 - 1000 MHz	4067	12/14/13
901263	Agilent Technologies	.01-12 GHz	SMA Detector	2936A05505	N/A

**Test Personnel:**

Daniel Baltzell Test Engineer	 Signature	October 3, 2013 Date of Test
----------------------------------	--	---------------------------------

**10 FCC Part 2.1047: Modulation Characteristics; IC RSS-119 5.8 Types of Modulation**

No data is presented since the radio is digitally modulated.

## 11 FCC Part 2.1049: Occupied Bandwidth; IC RSS-Gen Occupied Bandwidth

### 11.1 Bandwidth Test Procedure

The bandwidths per FCC and IC RSS-Gen were measured using a 50-ohm spectrum analyzer. The carrier was adjusted on the analyzer so that it was displayed entirely on the spectrum analyzer. The sweep time was set to auto and allowed through several sweeps in peak detector mode. The resolution and video bandwidths were set to auto. The bandwidths were measured using the spectrum analyzer auto function. The table below contains the bandwidth measurement results.

### 11.2 Bandwidth Test Data

Table 11-1: 99% Bandwidth Test Data

Frequency (MHz)	99% Bandwidth (kHz) 12.5 kHz Channel Spacing	99% Bandwidth (kHz) 25 kHz Channel Spacing
406.1	10.4	19.3
418.0	10.5	18.5
430.0	10.3	18.4
450.0	10.5	18.5
460.0	10.4	18.7
470.0	10.4	18.5

**Plot 11-1: Occupied Bandwidth 406.1 MHz; 12.5 kHz Channel Spacing**

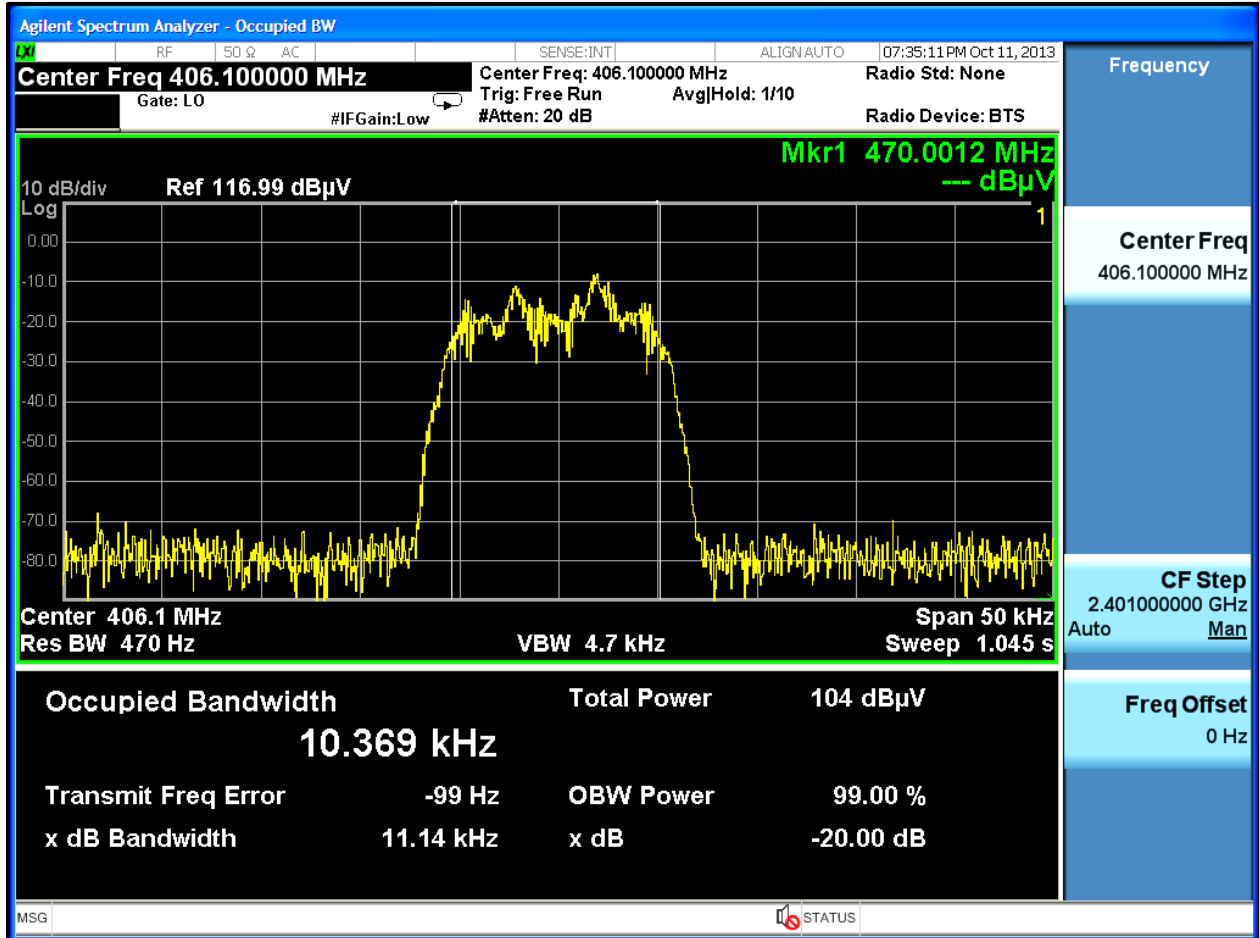

**Plot 11-2: Occupied Bandwidth 406.1 MHz; 25 kHz Channel Spacing**

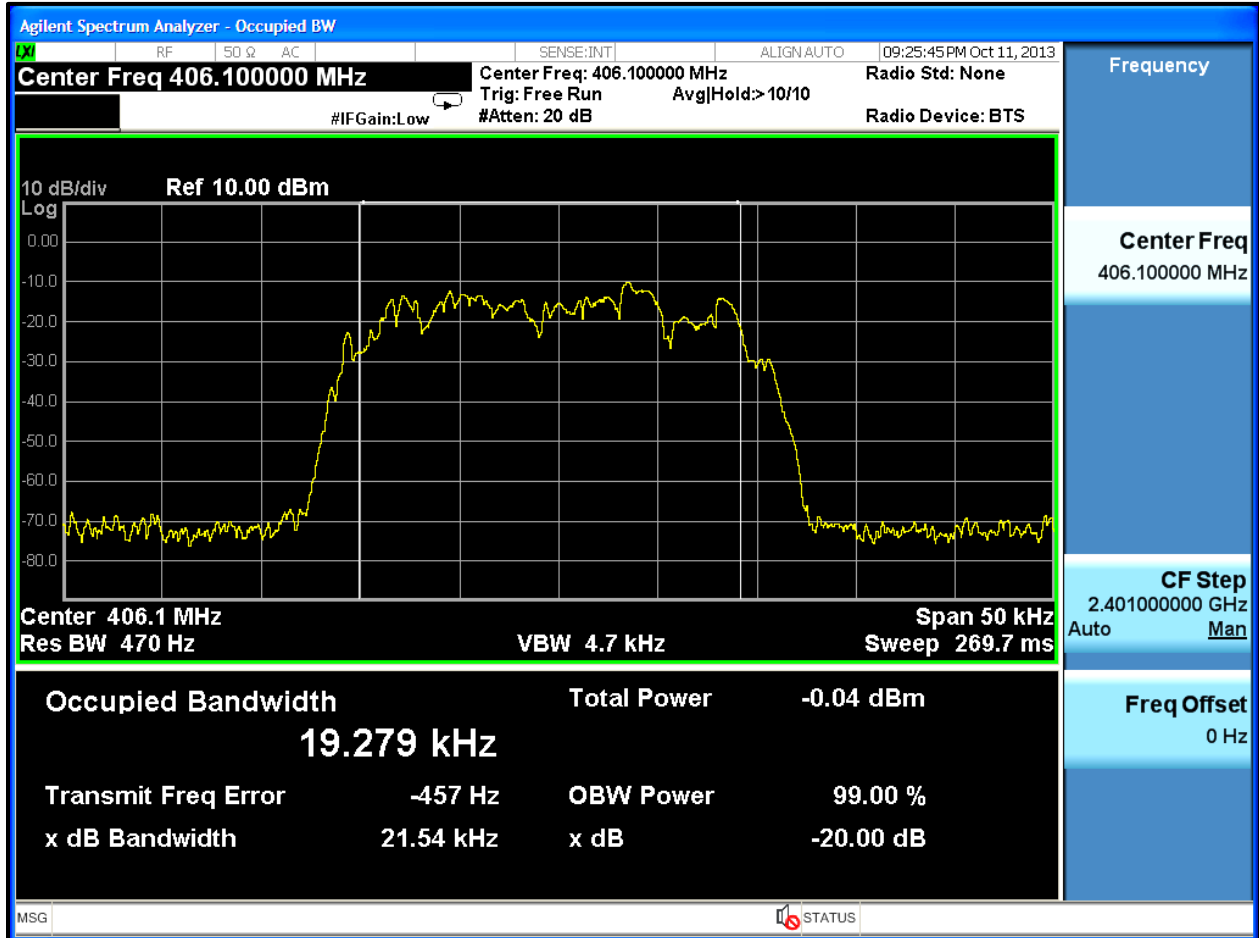

**Plot 11-3: Occupied Bandwidth 418.0 MHz; 12.5 kHz Channel Spacing**

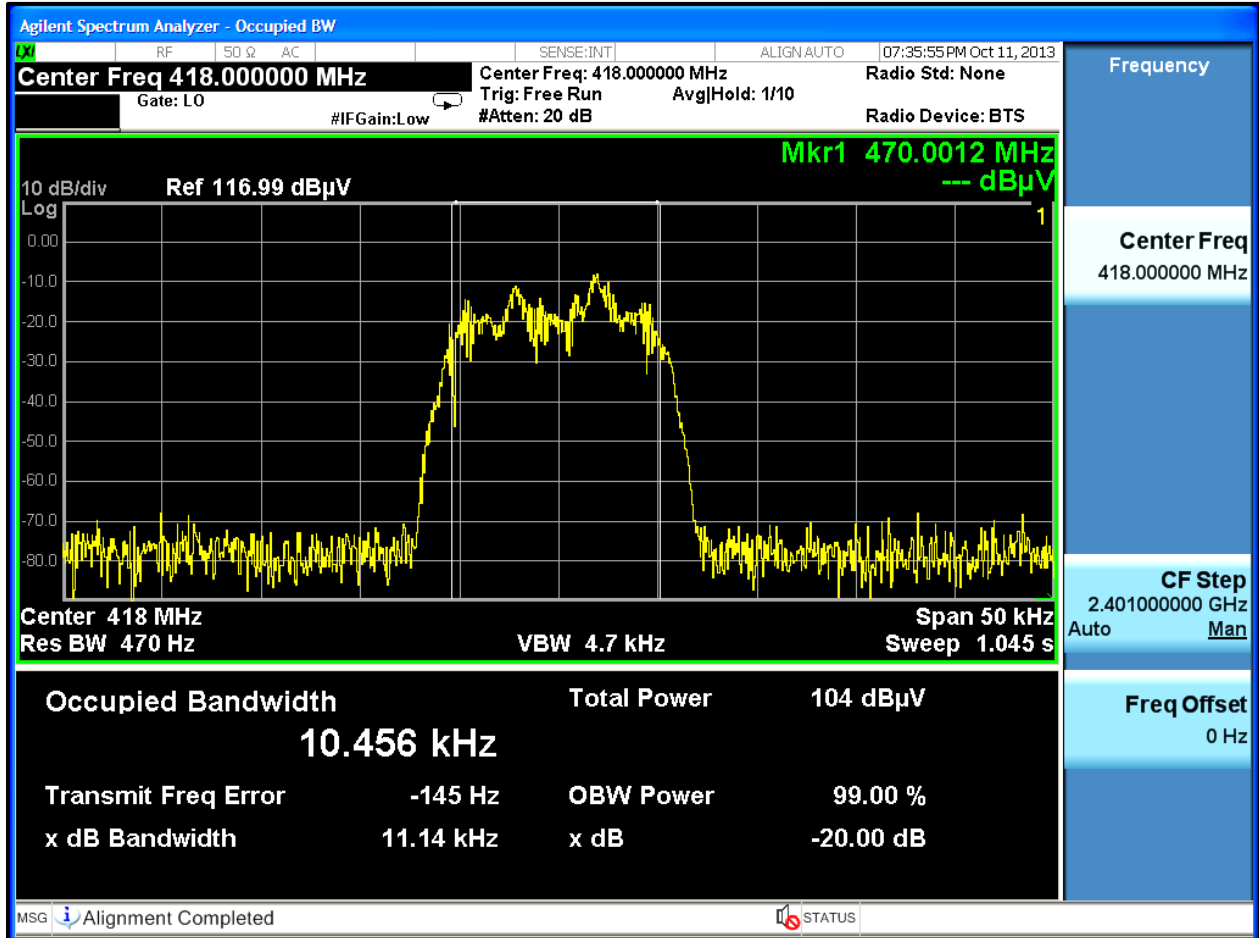



**Plot 11-4: Occupied Bandwidth 418.0 MHz; 25 kHz Channel Spacing**

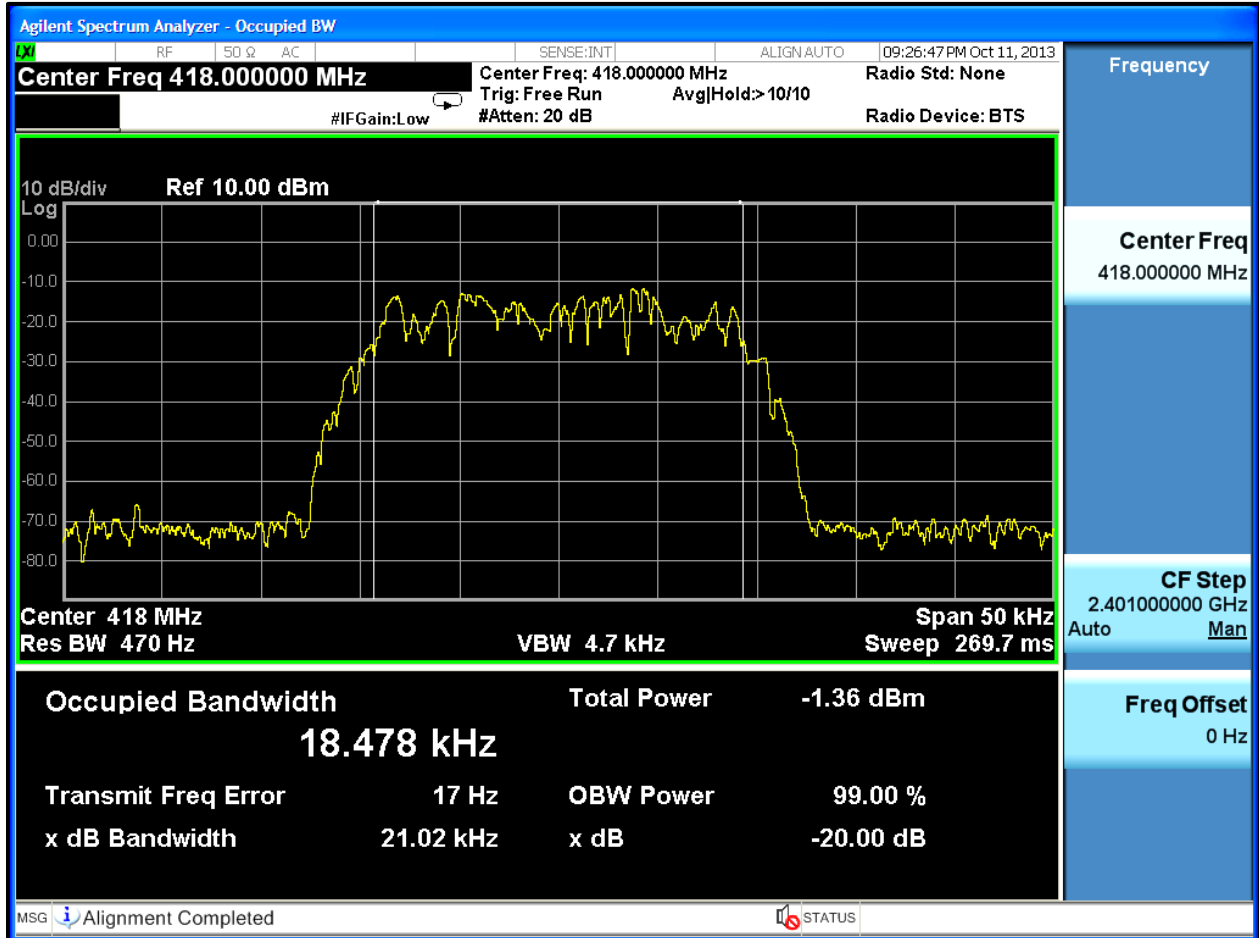

**Plot 11-5: Occupied Bandwidth 430.0 MHz; 12.5 kHz Channel Spacing**

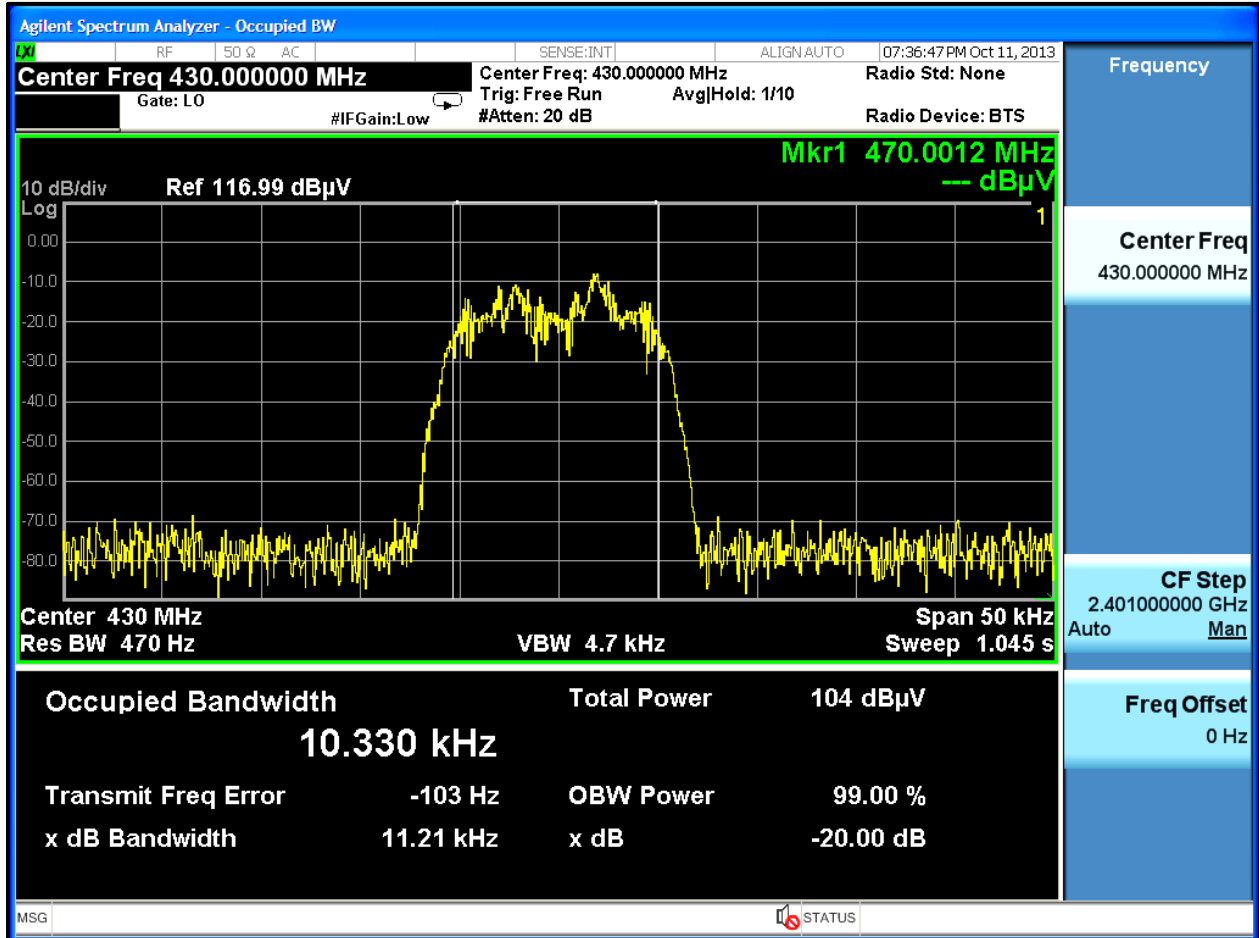

**Plot 11-6: Occupied Bandwidth 430.0 MHz; 25 kHz Channel Spacing**

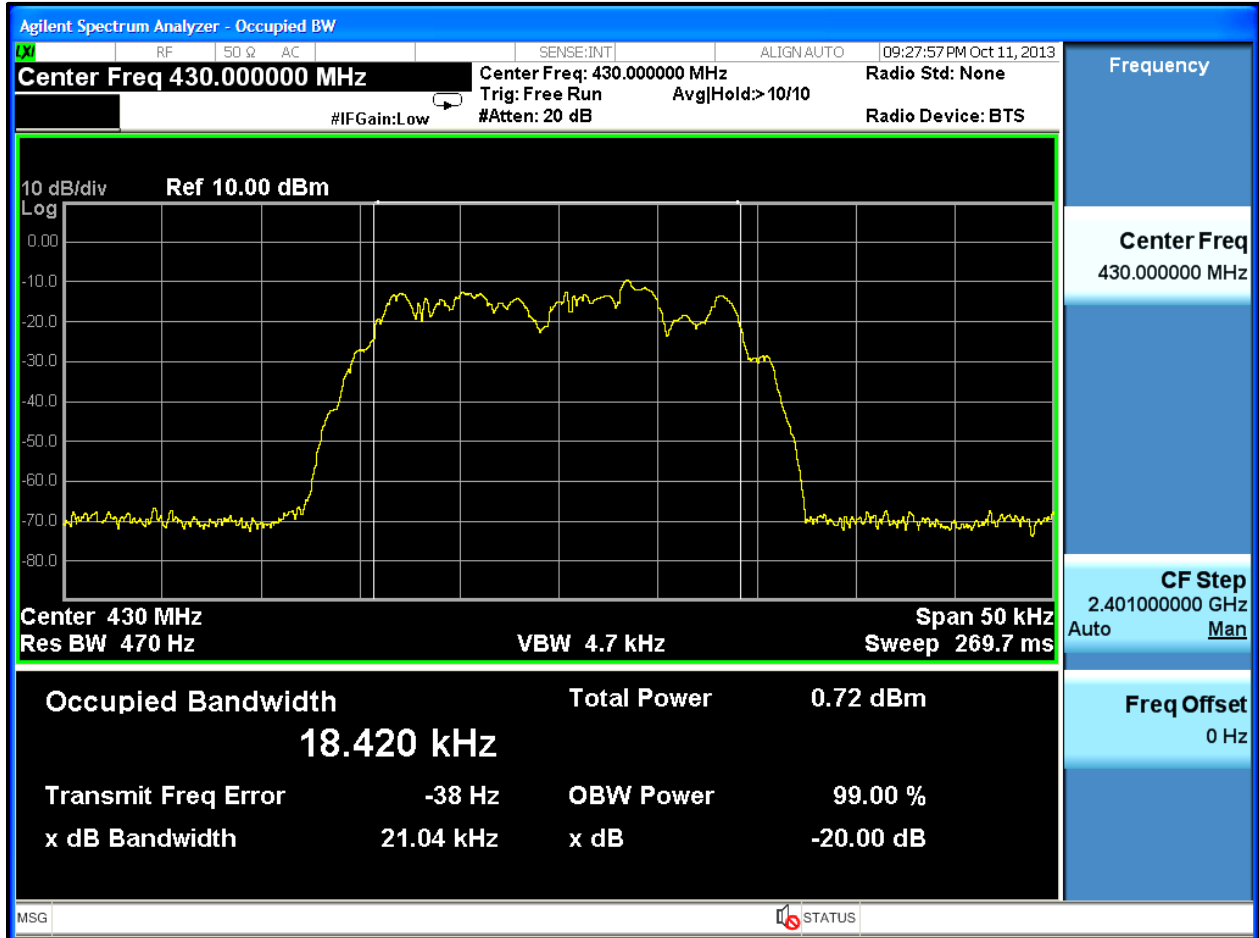

**Plot 11-7: Occupied Bandwidth 450.0 MHz; 12.5 kHz Channel Spacing**

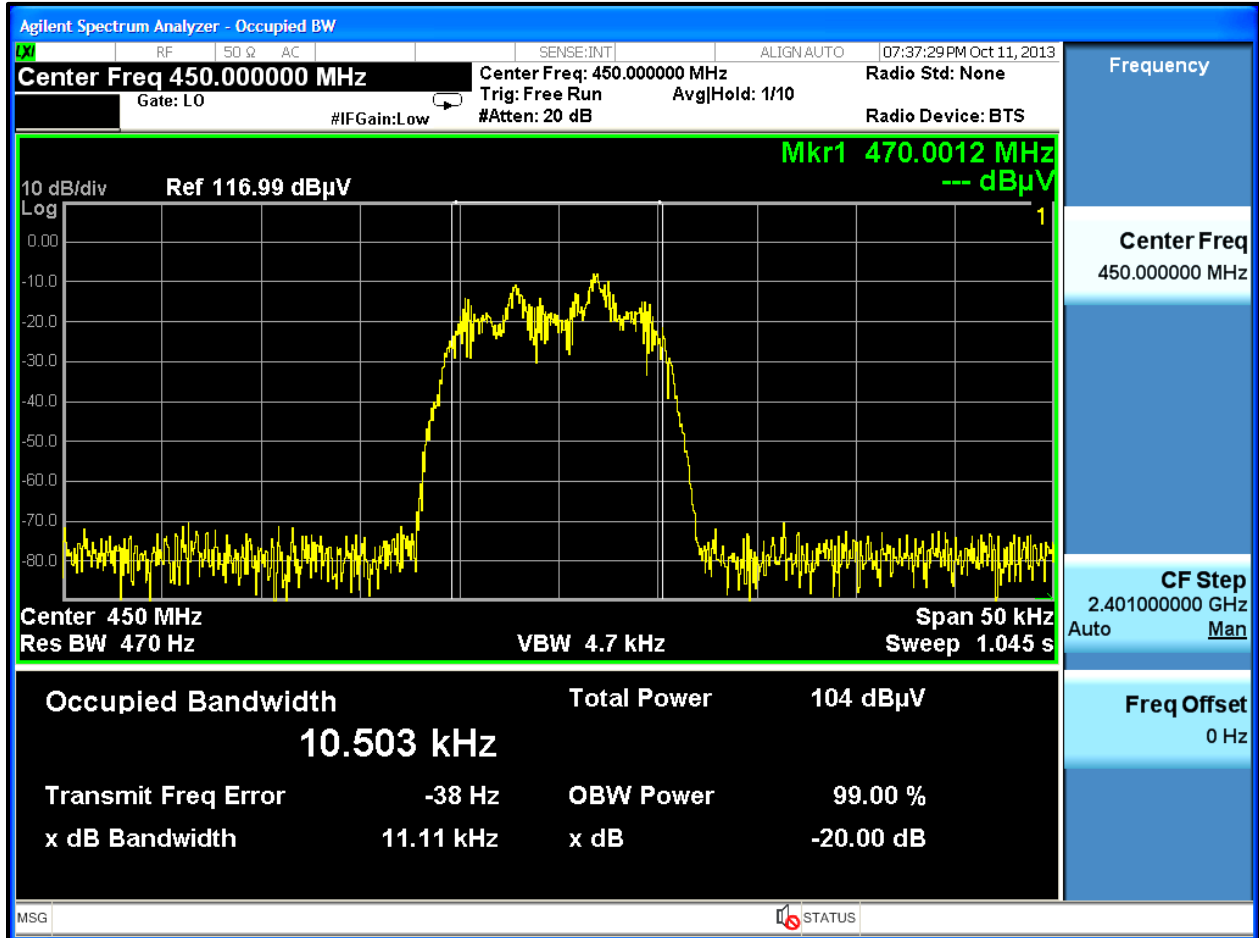

**Plot 11-8: Occupied Bandwidth 450.0 MHz; 25 kHz Channel Spacing**

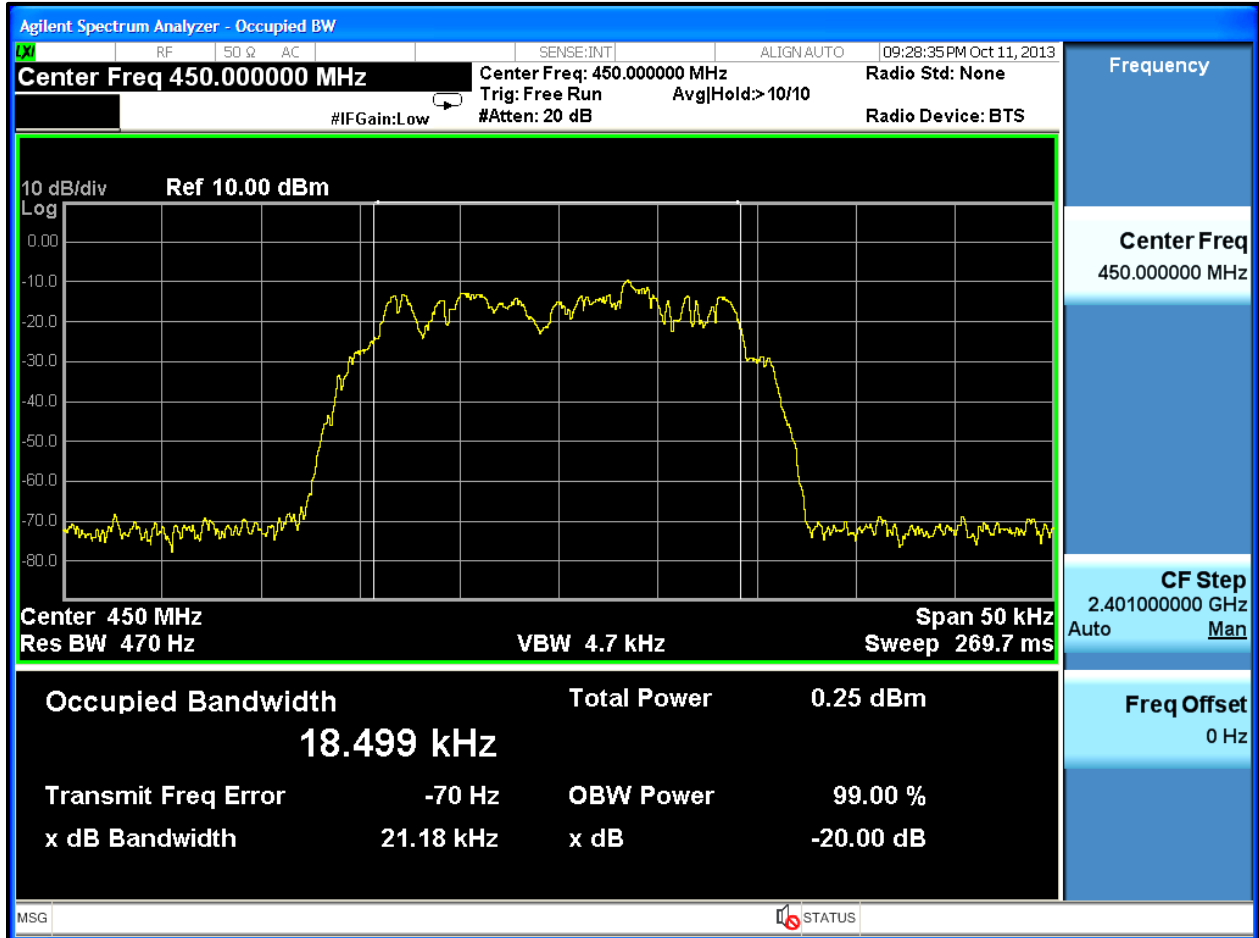

**Plot 11-9: Occupied Bandwidth 460.0 MHz; 12.5 kHz Channel Spacing**

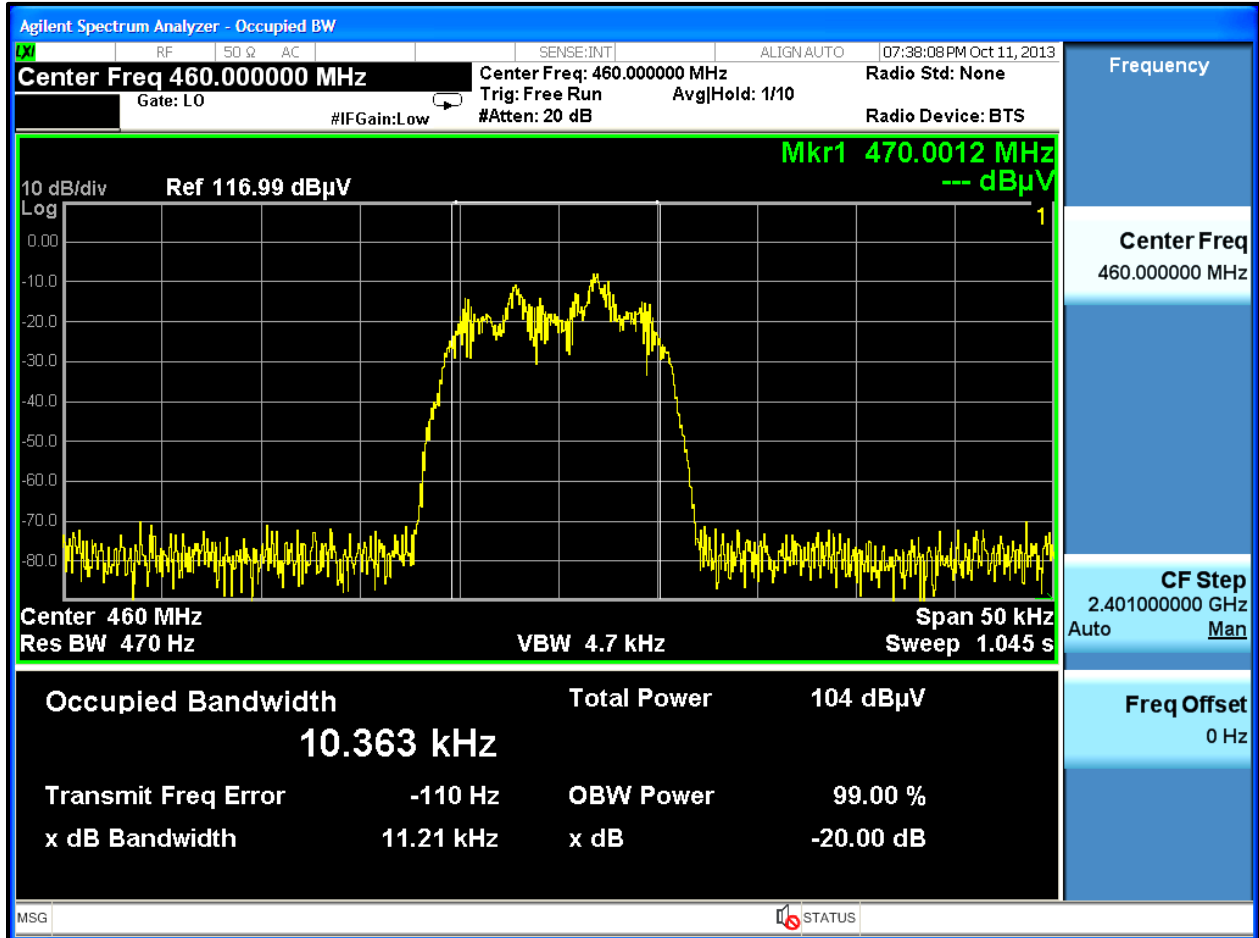

**Plot 11-10: Occupied Bandwidth 460.0 MHz; 25 kHz Channel Spacing**

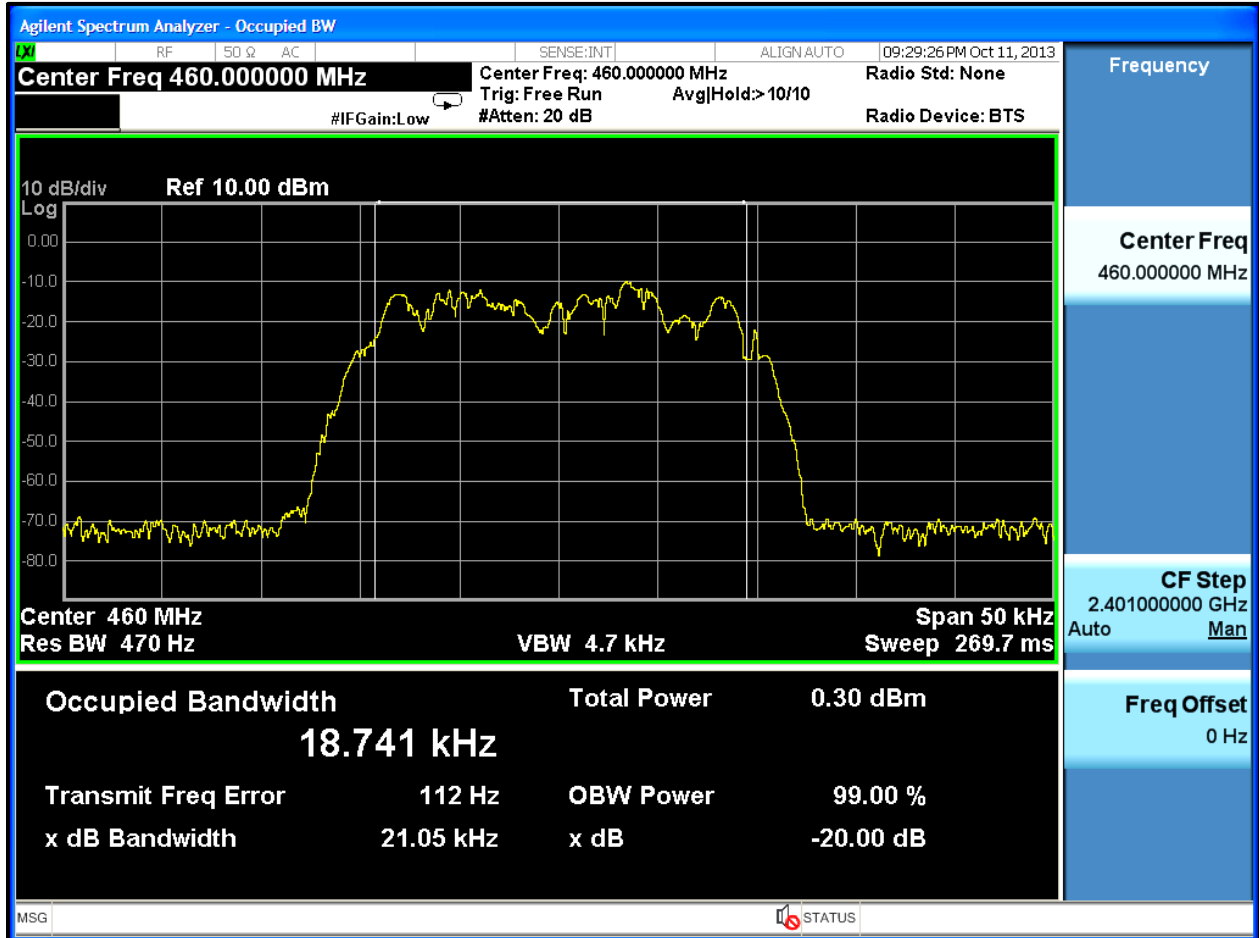

**Plot 11-11: Occupied Bandwidth 470.0 MHz; 12.5 kHz Channel Spacing**

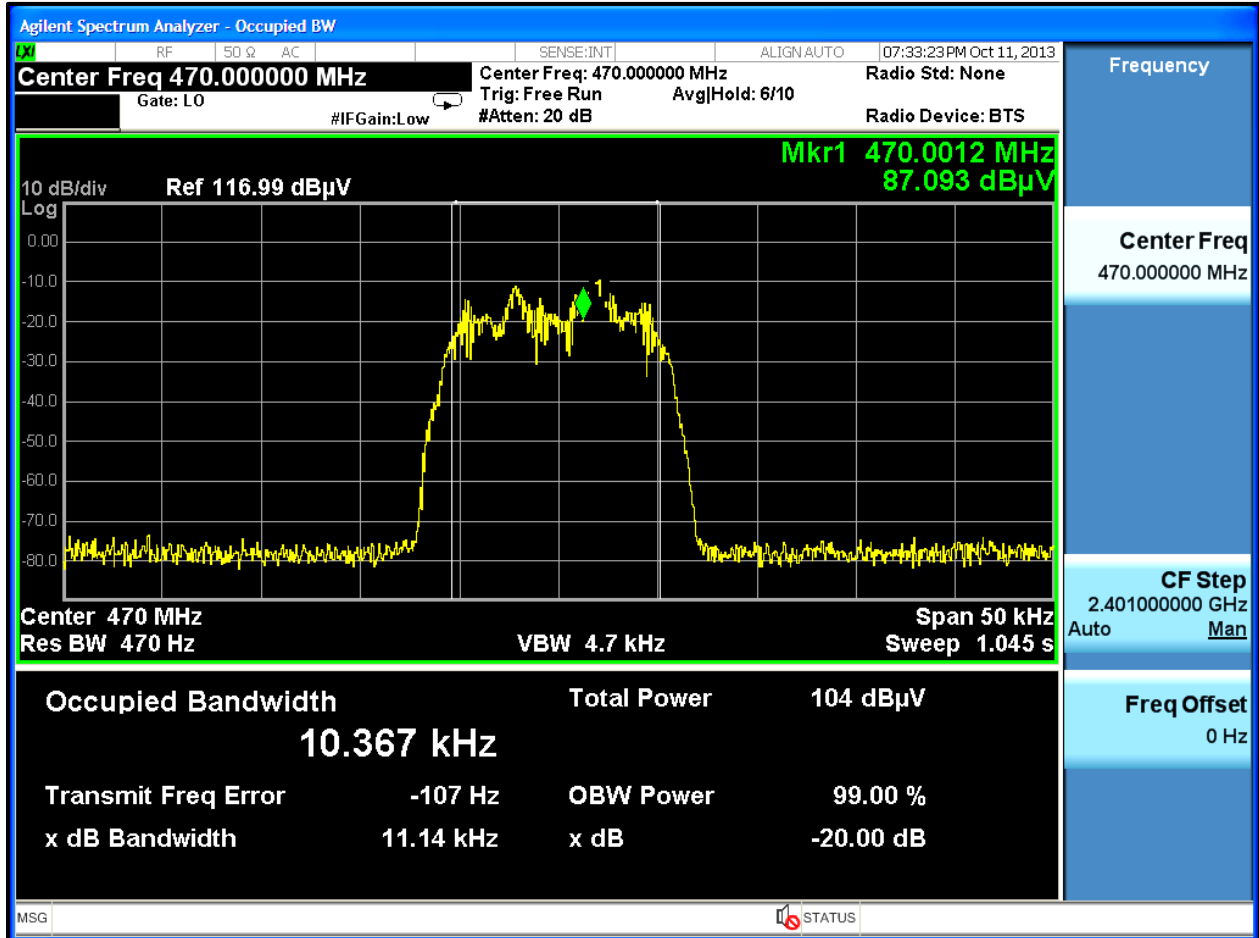



**Plot 11-12: Occupied Bandwidth 470.0 MHz; 25 kHz Channel Spacing**

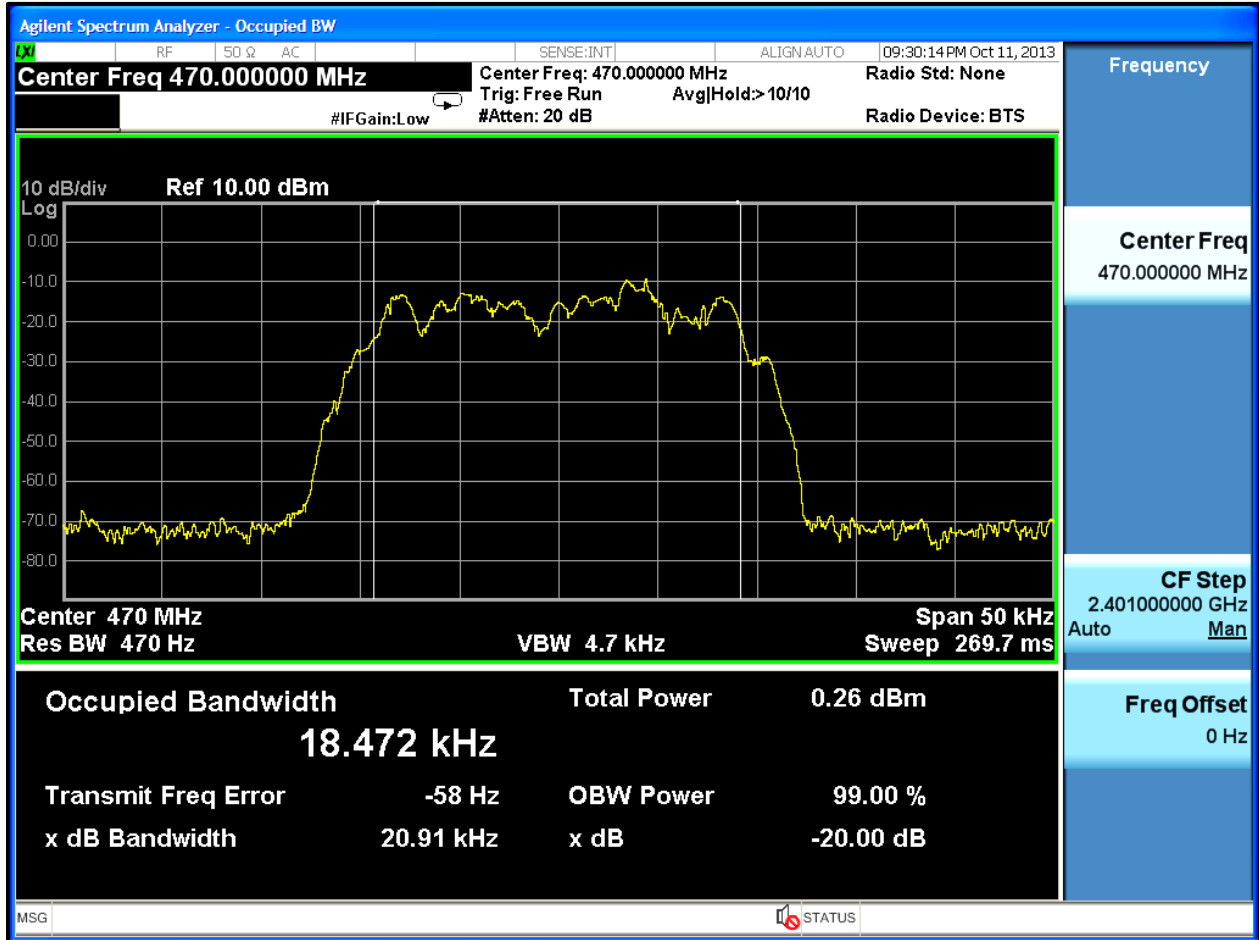

**Table 11-2: Test Equipment Used For Testing Transient Frequency Behavior**

RTL Asset #	Manufacturer	Model	Part Type	Serial Number	Calibration Due Date
901583	Agilent Technologies	N9010A	EXA Signal Analyzer (10 Hz - 26.5 GHz)	MY51250846	4/16/14
901139	Weinschel Corp.	48-20-34 DC-18GHz	Attenuator, 100W 20dB	BK5859	3/25/16
900948	Weinschel Corporation	47-10-43	Attenuator DC-18 GHz 10 dB 50W	BH1487	3/18/14

**Test Personnel:**

Daniel Baltzell  
 Test Engineer

Signature

October 7-11, 2013  
 Dates of Test

Rhein Tech Laboratories, Inc.  
360 Herndon Parkway  
Suite 1400  
Herndon, VA 20170  
<http://www.rheintech.com>

Client: 4RF Limited  
Model: SQ400M131  
ID's: UIPSQ400M131/6772A-SQ400M131  
Standards: FCC Part 90/IC RSS-119  
Report Number: 2013202

## 12 Conclusion

The data in this measurement report shows that the **4RF Limited Aprisa SR+ Model SQ400M131, FCC ID: UIPSQ400M131, IC: 6772A-SQ400M131**, complies with the applicable requirements of FCC Parts 2 and 90 and Industry Canada RSS-119.