

# RF MEASUREMENT REPORT

---

**FCC ID:** UIDW6  
**Applicant:** ARRIS  
**Product:** Wireless Router  
**Model No.:** W6B, W6U  
**FCC Classification:** 15E 6 GHz Low Power Indoor Access Point (6ID)  
15E 6 GHz Subordinate Indoor Device (6PP)  
**FCC Rule Part(s):** Part 15 Subpart E (Section 15.407)  
**Test Date:** December 11, 2021 ~ April 28, 2022

**Reviewed By:**

\_\_\_\_\_  
Vincent Yu

**Approved By:**

\_\_\_\_\_  
Robin Wu



The test results relate only to the samples tested.

This equipment has been shown to be capable of compliance with the applicable technical standards as indicated in the measurement report and was tested in accordance with the measurement procedures specified in KDB 987594 D02v01. Test results reported herein relate only to the item(s) tested.

The test report shall not be reproduced except in full without the written approval of MRT Technology (Suzhou) Co., Ltd.

**Revision History**

Report No.	Version	Description	Issue Date	Note
2111RSU095-U1	Rev. 01	Initial Report	05-18-2022	Valid

## CONTENTS

Description	Page
<b>1. General Information .....</b>	<b>6</b>
1.1. Applicant .....	6
1.2. Manufacturer .....	6
1.3. Testing Facility .....	6
1.4. Product Information.....	7
1.5. Radio Specification .....	7
1.6. Working Frequencies .....	8
1.7. Antenna Details.....	9
<b>2. Test Configuration .....</b>	<b>10</b>
2.1. Test Mode .....	10
2.2. Test System Connection Diagram .....	10
2.3. Test Software .....	11
2.4. Applied Standards.....	12
2.5. Test Environment Condition .....	12
<b>3. Antenna Requirements .....</b>	<b>13</b>
<b>4. Measuring Instrument .....</b>	<b>14</b>
<b>5. Measurement Uncertainty.....</b>	<b>15</b>
<b>6. Test Result.....</b>	<b>16</b>
6.1. Summary .....	16
6.2. 26dB & 99% Bandwidth Measurement .....	17
6.2.1. Test Limit .....	17
6.2.2. Test Procedure .....	17
6.2.3. Test Setting .....	17
6.2.4. Test Setup .....	18
6.2.5. Test Result .....	18
6.3. Output Power Measurement .....	19
6.3.1. Test Limit .....	19
6.3.2. Test Procedure .....	19
6.3.3. Test Setting .....	19
6.3.4. Test Setup .....	20
6.3.5. Test Result .....	20
6.4. Power Spectral Density Measurement .....	21
6.4.1. Test Limit .....	21
6.4.2. Test Procedure .....	21
6.4.3. Test Setting .....	21

---

6.4.4.	Test Setup .....	22
6.4.5.	Test Result .....	22
6.5.	In-Band Emission Measurement.....	23
6.5.1.	Test Limit .....	23
6.5.2.	Test Procedure.....	23
6.5.3.	Test Setting .....	23
6.5.4.	Test Setup .....	24
6.5.5.	Test Result .....	24
6.6.	Frequency Stability Measurement .....	25
6.6.1.	Test Limit .....	25
6.6.2.	Test Procedure.....	25
6.6.3.	Test Setup .....	26
6.6.4.	Test Result .....	26
6.7.	Contention Based Protocol Measurement.....	27
6.7.1.	Test Limit .....	27
6.7.2.	Test Procedure.....	27
6.7.3.	Test Setting .....	27
6.7.4.	Test Setup .....	28
6.7.5.	Test Result .....	28
6.8.	Radiated Spurious Emission Measurement .....	29
6.8.1.	Test Limit .....	29
6.8.2.	Test Procedure.....	29
6.8.3.	Test Setting .....	29
6.8.4.	Test Setup .....	31
6.8.5.	Test Result .....	31
6.9.	Radiated Restricted Band Edge Measurement .....	32
6.9.1.	Test Limit .....	32
6.9.2.	Test Procedure.....	33
6.9.3.	Test Setting .....	33
6.9.4.	Test Setup .....	34
6.9.5.	Test Result .....	34
6.10.	AC Conducted Emissions Measurement .....	35
6.10.1.	Test Limit.....	35
6.10.2.	Test Setup.....	35
6.10.3.	Test Result.....	35
<b>Appendix A - Test Result.....</b>		<b>36</b>
A.1	Duty Cycle Test Result.....	36
A.2	26dB & 99% Bandwidth Test Result .....	38

---

---

A.3	Output Power Test Result .....	49
A.4	Power Spectral Density Test Result.....	51
A.5	In-Band Emission Measurement .....	66
A.6	Frequency Stability Test Result .....	154
A.7	Contention Based Protocol Test Result.....	155
A.8	Radiated Spurious Emission Test Result .....	167
A.9	Radiated Restricted Band Edge Test Result .....	225
A.10	AC Conducted Emissions Test Result .....	265
<b>Appendix B - Test Setup Photograph .....</b>		<b>267</b>
<b>Appendix C - EUT Photograph .....</b>		<b>268</b>



#### 1.4. Product Information

Product Name	Wireless Router
Model No.	W6B, W6U
EUT Identification No.	1K3543111100007, 1K3543111100008
Wi-Fi Specification	802.11a/ax
Antenna Information	Refer to section 1.7
Power Type	AC/DC Adapter
Operating Temperature	0 ~ 40 °C
Accessories	
1# AC/DC Adapter	Model: WB-24M12FU Input: 100-120V ~ 60Hz, 0.7A Max. Output: 12V, 2A
2# AC/DC Adapter	Model: F24L15-120200SPAU Input: 100-240V ~ 50/60Hz, 0.6A Output: 12.0V, 2.0A, 24.0W
Remark:	
<p>1. The information of EUT was provided by the manufacturer, and the accuracy of the information shall be the responsibility of the manufacturer.</p> <p>2. Different models are to meet the needs of the market, and the difference is only the appearance color is different, the electrical characteristics are all the same.</p>	

#### 1.5. Radio Specification

Frequency Range	For 802.11a/ax-HE20: 5955 ~ 7095MHz For 802.11ax-HE40: 5965 ~ 7085MHz For 802.11ax-HE80: 5985 ~ 7025MHz For 802.11ax-HE160: 6025 ~ 6985MHz
Modulation	802.11a: OFDM 802.11ax: OFDMA
Data Rate	802.11a: up to 6/9/12/18/24/36/48/54Mbps 802.11ax: up to 4804Mbps

## 1.6. Working Frequencies

### 802.11a/ax-HE20

Channel	Frequency	Channel	Frequency	Channel	Frequency
01	5955 MHz	05	5975 MHz	09	5995 MHz
13	6015 MHz	17	6035 MHz	21	6055 MHz
25	6075 MHz	29	6095 MHz	33	6115 MHz
37	6135 MHz	41	6155 MHz	45	6175 MHz
49	6195 MHz	53	6215 MHz	57	6235 MHz
61	6255 MHz	65	6275 MHz	69	6295 MHz
73	6315 MHz	77	6335 MHz	81	6355 MHz
85	6375 MHz	89	6395 MHz	93	6415 MHz
97	6435 MHz	101	6455 MHz	105	6475 MHz
109	5495 MHz	113	6515 MHz	117	6535 MHz
121	6555 MHz	125	6575 MHz	129	6595 MHz
133	6615 MHz	137	6635 MHz	141	6655 MHz
145	6675 MHz	149	6695 MHz	153	6715 MHz
157	6735 MHz	161	6755 MHz	165	6775 MHz
169	6795 MHz	173	6815 MHz	177	6835 MHz
181	6855 MHz	185	6875 MHz	189	6895 MHz
193	6915 MHz	197	6935 MHz	201	6955 MHz
205	6975 MHz	209	6995 MHz	213	7015 MHz
217	7035 MHz	221	7055 MHz	225	7075 MHz
229	7095 MHz	--	--	--	--

### 802.11ax-HE40

Channel	Frequency	Channel	Frequency	Channel	Frequency
03	5965 MHz	11	6005 MHz	19	6045 MHz
27	6085 MHz	35	6125 MHz	43	6165 MHz
51	6205 MHz	59	6245 MHz	67	6285 MHz
75	6325 MHz	83	6365 MHz	91	6405 MHz
99	6445 MHz	107	6485 MHz	115	6525 MHz
123	6565 MHz	131	6605 MHz	139	6645 MHz
147	6685 MHz	155	6725 MHz	163	6765 MHz
171	6805 MHz	179	6845 MHz	187	6885 MHz
195	6925 MHz	203	6965 MHz	211	7005 MHz
219	7045 MHz	227	7085 MHz	--	--



## 802.11ax-HE80

Channel	Frequency	Channel	Frequency	Channel	Frequency
07	5985 MHz	23	6065 MHz	39	6145 MHz
55	6225 MHz	71	6305 MHz	87	6385 MHz
103	6465 MHz	119	6545 MHz	135	6625 MHz
151	6705 MHz	167	6785 MHz	183	6865 MHz
199	6945 MHz	215	7025 MHz	--	--

## 802.11ax-HE160

Channel	Frequency	Channel	Frequency	Channel	Frequency
15	6025 MHz	47	6185 MHz	79	6345 MHz
111	6505 MHz	143	6665 MHz	175	6825 MHz
207	6985 MHz	--	--	--	--

**1.7. Antenna Details**

Antenna Type	Frequency Band	N <sub>ANT</sub>	N <sub>SS</sub>	Max. Antenna Gain (dBi)	Directional Gain (dBi)	
					CDD	Beamforming
PCB Antenna	5925 ~ 7125	4	1	2.90	2.90	8.92

## Remark:

- The EUT supports Cyclic Delay Diversity (CDD) mode, and CDD signals are correlated.  
CDD Directional Gain = Max. Antenna Gain + Array Gain, Array Gain = 0 dB for  $N_{ANT} \leq 4$ ;
- The EUT also supports Beam Forming mode, and the Beam Forming support 802.11ax only, not include 802.11a. The EIRP power in the beamforming mode will be less than or equal to the EIRP power in the CDD mode as declared by manufacturer. Therefore, only CDD mode was evaluated in this report.  
Beamforming Directional Gain = Max. Antenna Gain +  $10 \cdot \log(N_{ANT}/N_{SS})$

## 2. Test Configuration

### 2.1. Test Mode

Mode 1: Transmit by 802.11a (6Mbps) (CDD mode)
Mode 2: Transmit by 802.11ax-HE20 (MCS0) (CDD mode)
Mode 3: Transmit by 802.11ax-HE40 (MCS0) (CDD mode)
Mode 4: Transmit by 802.11ax-HE80 (MCS0) (CDD mode)
Mode 5: Transmit by 802.11 ax-HE160 (MCS0) (CDD mode)

### 2.2. Test System Connection Diagram

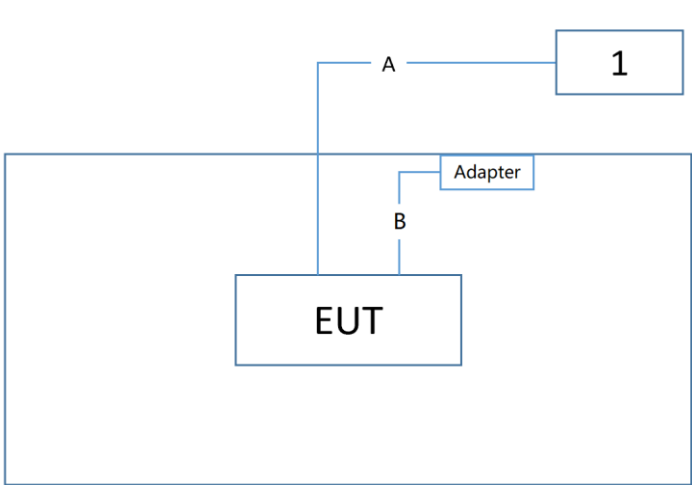
Connection Diagram - Radiated Emission testing & AC Conducted Emissions			
			
Cable Type		Cable Description	
A	LAN Cable	Non shielded, > 10m	
B	Power Cable	Non shielded, < 2.0m	
Product	Manufacturer		Model No.
1	Notebook	Lenovo	E495

### 2.3. Test Software

The test utility software used during testing was “QSPR.exe”, and the version was “5.0-00188”.

The power setting as below.

Test Mode	Channel No.	Frequency (MHz)	Power Setting	Test Mode	Channel No.	Frequency (MHz)	Power Setting
11a	01	5955	8.0	11ax-HE40	03	5965	11.0
	49	6195	8.0		51	6205	11.0
	93	6415	9.5		91	6405	11.0
	97	6435	9.5		99	6445	11.5
	105	6475	9.5		107	6485	11.0
	113	6515	9.5		115	6525	10.0
	117	6535	9.0		123	6565	10.0
	153	6715	10.5		147	6685	11.0
	181	6855	10.0		179	6845	12.0
	185	6875	10.0		187	6885	12.0
	189	6895	10.5		195	6925	11.0
	213	7015	10.0		211	7005	11.0
	229	7095	11.0		227	7085	11.0
11ax-HE20	01	5955	8.0	11ax-HE80	07	5985	13.5
	49	6195	8.0		55	6225	13.5
	93	6415	8.5		87	6385	14.5
	97	6435	7.5		103	6465	14.0
	105	6475	8.0		119	6545	13.0
	113	6515	6.5		135	6625	13.5
	117	6535	7.5		151	6705	14.0
	153	6715	8.0		183	6865	14.0
	181	6855	7.5		199	6945	14.0
	185	6875	7.5		215	7025	14.0
	189	6895	7.5	11ax-HE160	15	6025	16.0
	213	7015	8.0		47	6185	16.0
	229	7095	9.5		79	6345	17.5
--	--	--	111		6505	16.5	
--	--	--	--	143	6665	16.5	
--	--	--	--	175	6825	17.0	
--	--	--	--	207	6985	17.0	

#### 2.4. Applied Standards

According to the specifications of the manufacturer, the EUT must comply with the requirements of the following standards:

- ANSI C63.10-2013
- FCC KDB 789033 D02v02r01
- FCC KDB 987594 D02v01r01
- FCC KDB 662911 D01v02r01
- FCC KDB 414788 D01v01r01
- FCC KDB 412172 D01v01r01

#### 2.5. Test Environment Condition

Ambient Temperature	15 ~ 35°C
Relative Humidity	20 ~ 75%RH

### 3. Antenna Requirements

**Excerpt from §15.407(a)(9) of the FCC Rules/Regulations:**

Access points operating under the provisions of paragraphs (a)(5) and (a)(6) of this section must employ a permanently attached integrated antenna.

- The antenna of the device is built in and locked inside the enclosure.

**Conclusion:**

The device complies with the requirement of §15.407(a)(9).

#### 4. Measuring Instrument

Instrument	Manufacturer	Model No.	Asset No.	Last Cali. Date	Cali. Due Date	Test Site
Loop Antenna	Schwarzbeck	FMZB 1519	MRTSUE06025	1 year	2022/10/28	WZ-AC2
Horn Antenna	ETS	3117	MRTSUE06257	1 year	2022/9/25	WZ-AC2
Horn Antenna	Schwarzbeck	BBHA 9170	MRTSUE06597	1 year	2022/12/1	WZ-AC2
Preamplifier	EMCI	EMC184045SE	MRTSUE06640	1 year	2023/1/13	WZ-AC2
Preamplifier	EMCI	EMC051845SE	MRTSUE06987	1 year	2022/9/9	WZ-AC2
TRILOG Antenna	Schwarzbeck	VULB 9162	MRTSUE06022	1 year	2022/5/24	WZ-AC2
EMI Test Receiver	Agilent	N9038A	MRTSUE06125	1 year	2022/6/24	WZ-AC2
Thermohygrometer	Mingle	ETH529	MRTSUE06170	1 year	2022/12/1	WZ-AC2
Horn Antenna	Schwarzbeck	BBHA 9120D	MRTSUE06171	1 year	2022/10/21	WZ-AC2
Preamplifier	Schwarzbeck	BBV 9718	MRTSUE06176	1 year	2022/11/12	WZ-AC2
Anechoic Chamber	RIKEN	WZ-AC2	MRTSUE06213	1 year	2022/4/29	WZ-AC2
Thermohygrometer	testo	Testo 608-H1	MRTSUE11038	1 year	2022/11/11	WZ-AC2
Two-Line V-Network	R&S	ENV216	MRTSUE06002	1 year	2022/6/8	WZ-SR2
ISN	Teseq	ISN T800	MRTSUE06005	1 year	2022/12/30	WZ-SR2
Shielding Room	MIX-BEP	WZ-SR2	MRTSUE06215	5 years	2026/12/20	WZ-SR2
Thermohygrometer	testo	608-H1	MRTSUE06404	1 year	2022/6/28	WZ-SR2
Four-Line V-Network	R&S	ENV432	MRTSUE06615	1 year	2022/10/13	WZ-SR2
EMI Test Receiver	R&S	ESR3	MRTSUE06909	1 year	2022/11/1	WZ-SR2
Signal Analyzer	Agilent	N9020A	MRTSUE06106	1 year	2022/4/13	WZ-SR5
Thermohygrometer	testo	608-H1	MRTSUE06402	1 year	2022/6/28	WZ-SR5
Shielding Room	HUAMING	WZ-SR5	MRTSUE06442	/	/	WZ-SR5
Signal Analyzer	Keysight	N9010B	MRTSUE06457	1 year	2022/6/24	WZ-SR5
Signal Generator	Keysight	N5182B	MRTSUE06451	1 year	2022/6/24	WZ-SR5
Frequency extender for EXG or MXG	Keysight	N5182BX07	MRTSUE06984	1 year	2022/3/7	WZ-SR5
Preamplifier	EMCI	EMC051845SE	MRTSUE06987	1 year	2022/9/9	WZ-SR5
Temperature Chamber	BAOYT	BYH-150CL	MRTSUE06051	1 year	2022/10/10	WZ-TR3
Signal Analyzer	Keysight	N9010B	MRTSUE07027	1 year	2022/12/5	WZ-TR3
Thermohygrometer	testo	608-H1	MRTSUE06401	1 year	2022/6/28	WZ-TR3

Software	Version	Function
EMI Software	V3	EMI Test Software

## 5. Measurement Uncertainty

Where relevant, the following test uncertainty levels have been estimated for tests performed on the EUT as specified in CISPR 16-4-2. This uncertainty represents an expanded uncertainty expressed at approximately the 95% confidence level using a coverage factor of  $k = 2$ .

<b>AC Conducted Emission Measurement</b>
Measurement Uncertainty for a Level of Confidence of 95% ( $U=2Uc(y)$ ): 9kHz~150kHz: 3.74dB 150kHz~30MHz: 3.44dB
<b>Radiated Emission Measurement</b>
Measurement Uncertainty for a Level of Confidence of 95% ( $U=2Uc(y)$ ): Horizontal: 30MHz~300MHz: 5.04dB 300MHz~1GHz: 4.95dB 1GHz~40GHz: 6.40dB Vertical: 30MHz~300MHz: 5.24dB 300MHz~1GHz: 6.03dB 1GHz~40GHz: 6.40dB
<b>Spurious Emissions, Conducted</b>
Measuring Uncertainty for a Level of Confidence of 95% ( $U=2Uc(y)$ ): 0.78dB
<b>Output Power</b>
Measuring Uncertainty for a Level of Confidence of 95% ( $U=2Uc(y)$ ): 1.13dB
<b>Power Spectrum Density</b>
Measuring Uncertainty for a Level of Confidence of 95% ( $U=2Uc(y)$ ): 1.15dB
<b>Occupied Bandwidth</b>
Measuring Uncertainty for a Level of Confidence of 95% ( $U=2Uc(y)$ ): 0.28%

## 6. Test Result

### 6.1. Summary

FCC Section(s)	Test Description	Test Condition	Verdict
15.407(a)	26dB & 99% Bandwidth	Conducted	Pass
15.407(b)(7)	In-Band Emission		Pass
15.407(d)(6)	Contention-Based Protocol		Pass
15.407(g)	Frequency Stability		Pass
15.407(a)(5), (a)(6)	Maximum Equivalent Isotropically Radiated Power (E.I.R.P)	Radiated	Pass
15.407(a)(5), (a)(6)	Peak Power Spectral Density (E.I.R.P)		Pass
15.407(b)(6)	Unwanted Emissions		Pass
15.407(b)(6), (7), (8), (9)	General Field Strength (Restricted Bands and Radiated Emission)		Pass
15.207	AC Conducted Emissions 150kHz - 30MHz	Line Conducted	Pass

#### Remark:

- The analyzer plots shown in this section were all taken with a correction table loaded into the analyzer. The correction table was used to account for the losses of the cables and attenuators used as part of the system to connect the EUT to the analyzer at all frequencies of interest.
- Output power test was verified over all data rates of each mode, and then choose the maximum power output (low data rate) for final test of each channel.
- For radiated emission test, every axis (X, Y, Z) was also verified. The test results shown in the following sections represent the worst-case emissions.
- EUT supports one configuration only in 802.11ax full RU mode.



## 6.2. 26dB & 99% Bandwidth Measurement

### 6.2.1. Test Limit

N/A

### 6.2.2. Test Procedure

KDB 789033 D02v02r01- Section II)C)1) (26dB Bandwidth)

KDB 789033 D02v02r01- Section II)D) (99% Bandwidth)

### 6.2.3. Test Setting

#### 26dB Bandwidth

1. The analyzers' automatic bandwidth measurement capability was used to perform the 26dB bandwidth
2. RBW = approximately 1% of the emission bandwidth.
3. VBW > RBW
4. Detector = Peak.
5. Trace mode = max hold.
6. Measure the maximum width of the emission that is 26 dB down from the maximum of the emission.  
Compare this with the RBW setting of the analyzer. Readjust RBW and repeat measurement as needed until the RBW/EBW ratio is approximately 1%.

#### 99% Bandwidth

1. Set center frequency to the nominal EUT channel center frequency.
2. RBW = 1% to 5% of the OBW
3. VBW  $\geq 3 \times$  RBW
4. Span = 1.5 times to 5 times the OBW
5. Detector = peak
6. Trace mode = max hold
7. Allow the trace to stabilize
8. Use the 99% power bandwidth function of the instrument.

#### 6.2.4. Test Setup

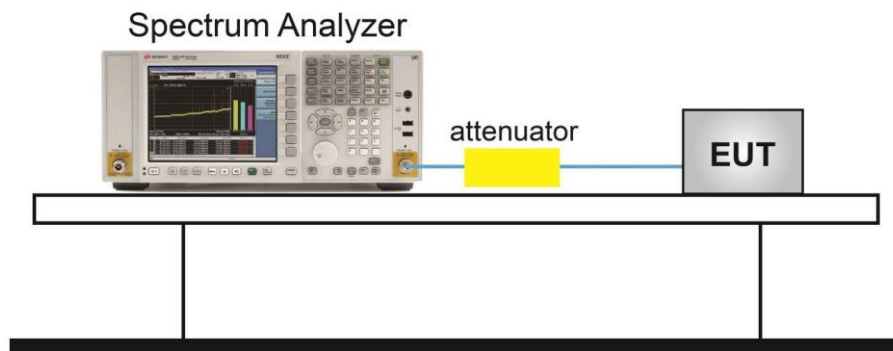

#### 6.2.5. Test Result

Refer to Appendix A.2.

### **6.3. Output Power Measurement**

#### **6.3.1. Test Limit**

For an indoor access point operating in the 5.925-7.125 GHz band, the maximum e.i.r.p. over the frequency band of operation must not exceed 30 dBm.

#### **6.3.2. Test Procedure**

KDB 789033D02v02r01- Section E)2)d) Method SA-2

#### **6.3.3. Test Setting**

1. Set span to encompass the EBW (or, alternatively, the entire 99% occupied bandwidth) of the signal
2. Set RBW = 1 MHz
3. Set VBW  $\geq$  3 MHz
4. Number of points in sweep  $\geq 2 \times$  span / RBW
5. Sweep time = auto
6. Detector = power averaging (rms)
7. Allow the sweep to "free run"
8. Trace average at least 100 traces in power averaging (rms) mode; however, the number of traces to be averaged shall be increased above 100 as needed to ensure that the average accurately represents the true average over the on and off periods of the transmitter.
9. Use the Channel Power function of the instrument.
10. Add  $10 \log (1/x)$ , where x is the duty cycle, to the measured power in order to compute the average power during the actual transmission times

### 6.3.4. Test Setup

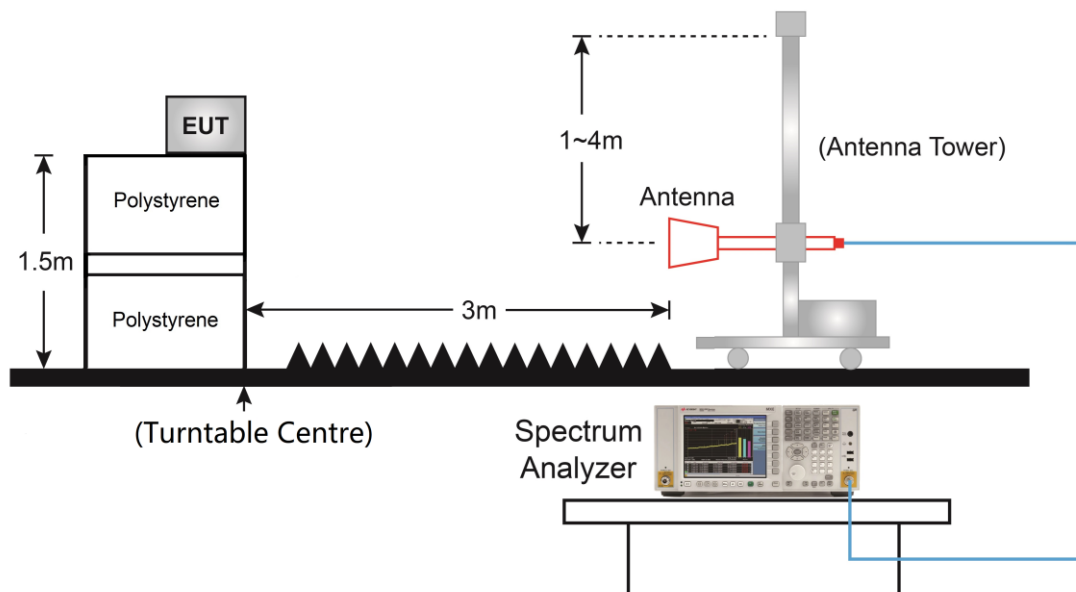

### 6.3.5. Test Result

Refer to Appendix A.3.

## **6.4. Power Spectral Density Measurement**

### **6.4.1. Test Limit**

For an indoor access point operating in the 5.925-7.125 GHz band, the maximum power spectral density must not exceed 5 dBm e.i.r.p. in any 1-megahertz band.

### **6.4.2. Test Procedure**

KDB 789033 D02v02r01-Section II)F)

### **6.4.3. Test Setting**

1. Analyzer was set to the center frequency of the UNII channel under investigation
2. Span was set to encompass the entire 26dB EBW of the signal.
3. RBW = 1MHz
4. VBW = 3MHz
5. Number of sweep points  $\geq 2 \times (\text{span} / \text{RBW})$
6. Detector = power averaging (Average)
7. Sweep time = auto
8. Trigger = free run
9. Use the peak search function on the instrument to find the peak of the spectrum and record its value.
10. Add  $10 \cdot \log(1/x)$ , where  $x$  is the duty cycle, to the measured power in order to compute the average power during the actual transmission times (because the measurement represents an average over both the on and off times of the transmission). For example, add  $10 \cdot \log(1/0.25) = 6$  dB if the duty cycle is 25 percent.

#### 6.4.4. Test Setup

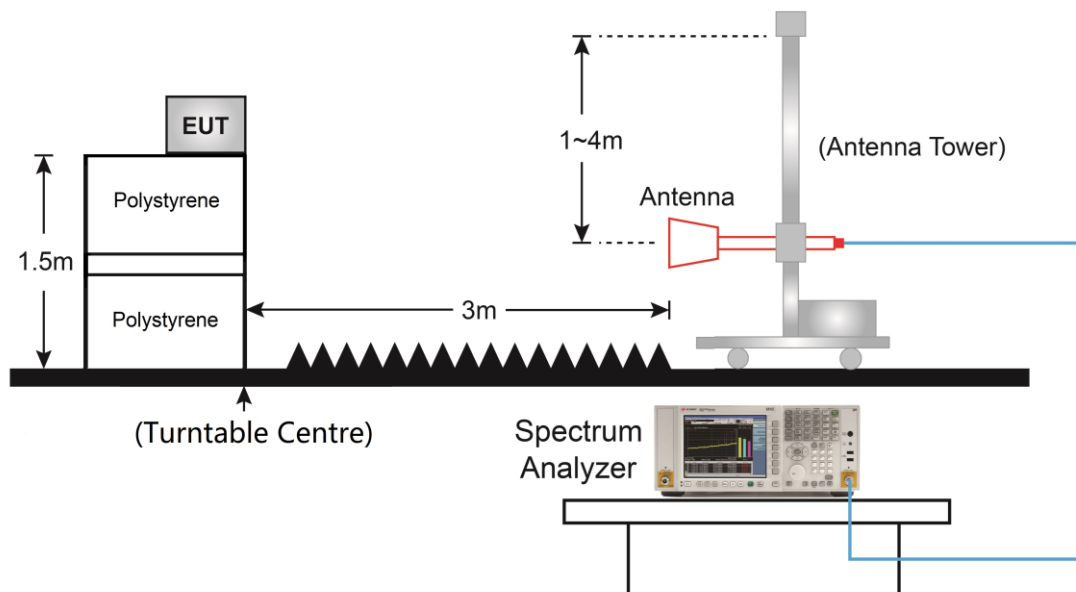

#### 6.4.5. Test Result

Refer to Appendix A.4.

## 6.5. In-Band Emission Measurement

### 6.5.1. Test Limit

Suppressed by 20 dB at 1 MHz outside of the channel edge. (The channel edge is defined as the 26-dB point on either side of the carrier center frequency.)

Suppressed by 28 dB at one channel bandwidth from the channel center.

Suppressed by 40 dB at one- and one-half times the channel bandwidth from the channel center.

### 6.5.2. Test Procedure

KDB 987594 D02v01r01- Section J

### 6.5.3. Test Setting

#### Emissions Mask Reference Level Measurement

1. Set the span to encompass the entire 26 dB EBW of the signal.
2. Set RBW = same RBW used for 26 dB EBW measurement.
3. Set VBW  $\geq 3 \times$  RBW.
4. Number of points in sweep  $\geq [2 \times \text{span} / \text{RBW}]$ .
5. Sweep time = auto.
6. Detector = RMS.
7. Trace average at least 100 traces in power averaging (rms) mode.
8. Use the peak search function on the instrument to find the peak of the spectrum.

#### In-Band Emission

1. Using the measuring equipment limit line function, develop the emissions mask based on rule.
2. Adjust the span to encompass the entire mask as necessary.
3. Clear trace.
4. Trace average at least 100 traces in power averaging (rms) mode.
5. Adjust the reference level as necessary so that the crest of the channel touches the top of the emission mask.

#### 6.5.4. Test Setup

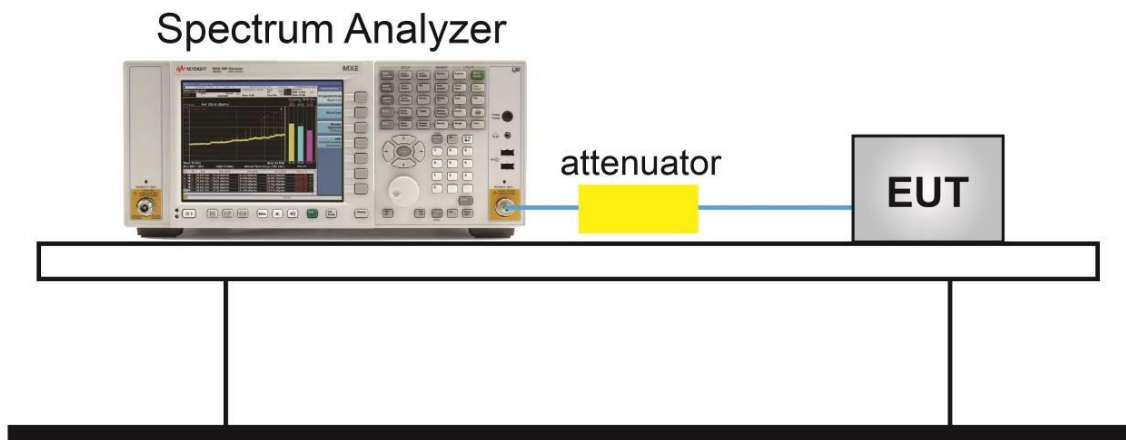

#### 6.5.5. Test Result

Refer to Appendix A.5.



## **6.6. Frequency Stability Measurement**

### **6.6.1. Test Limit**

Manufacturers of U-NII devices are responsible for ensuring frequency stability such that an emission is maintained within the band of operation under all conditions of normal operation as specified in the user's manual.

### **6.6.2. Test Procedure**

#### **Frequency Stability Under Temperature Variations:**

The equipment under test was connected to an external AC or DC power supply and input rated voltage. RF output was connected to a frequency counter or spectrum analyzer via feed through attenuators. The EUT was placed inside the temperature chamber. Set the spectrum analyzer RBW low enough to obtain the desired frequency resolution and measure EUT 20°C operating frequency as reference frequency. Turn EUT off and set the chamber temperature to highest. After the temperature stabilized for approximately 30 minutes recorded the frequency. Repeat step measure with 10°C decreased per stage until the lowest temperature reached.

#### **Frequency Stability Under Voltage Variations:**

Set chamber temperature to 20°C. Use a variable AC power supply / DC power source to power the EUT and set the voltage to rated voltage. Set the spectrum analyzer RBW low enough to obtain the desired frequency resolution and recorded the frequency.

Reduce the input voltage to specify extreme voltage variation ( $\pm 15\%$ ) and endpoint, record the maximum frequency change.

### 6.6.3. Test Setup

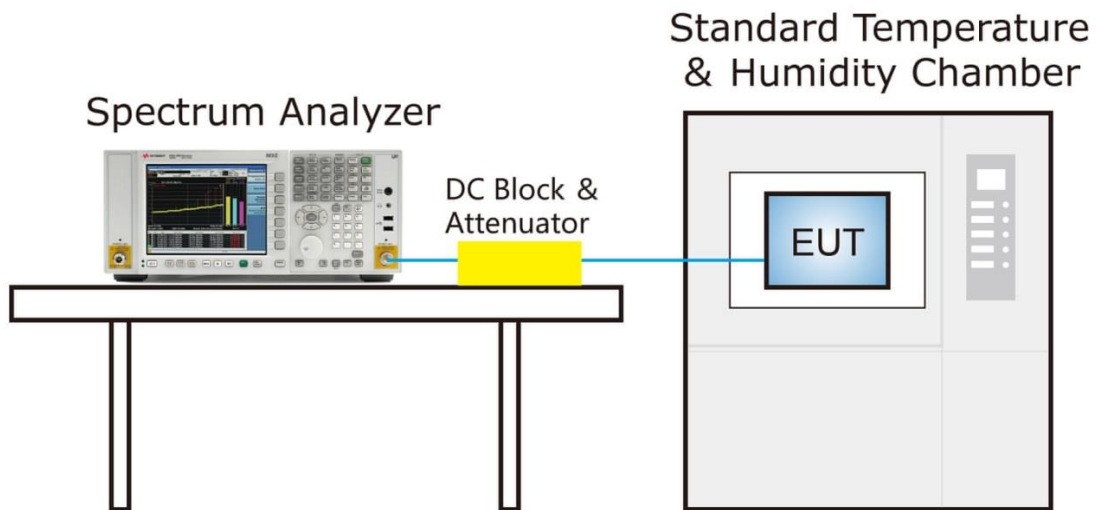

### 6.6.4. Test Result

Refer to Appendix A.6.

## **6.7. Contention Based Protocol Measurement**

### **6.7.1. Test Limit**

Unlicensed indoor low power device must detect co-channel radio frequency power that is at least -62dBm (The threshold is referenced to a 0dBi antenna gain.) or low.

Indoor low power device must detect an AWGN signal with 90% (or better) level of certainty.

### **6.7.2. Test Procedure**

KDB 987594 D02v01- Section I

### **6.7.3. Test Setting**

1. Configure the EUT to transmit with a constant duty cycle.
  2. Set the operating parameters of the EUT including power level, operating frequency, modulation and bandwidth.
  3. Set the signal analyzer center frequency to the nominal EUT channel center frequency. The span range of the signal analyzer shall be between two times and five times the OBW of the EUT.  
Connect the output port of the EUT to the signal analyzer 2. Ensure that the attenuator 2 provides enough attenuation to not overload the signal analyzer 2 receiver.
  4. Monitoring the signal analyzer 2, verify the EUT is operating and transmitting with the parameters set at step two.
  5. Using an AWGN signal source, generate a 10 MHz-wide AWGN signal. Use Table 1 of KDB 987594 to determine the center frequency of the 10 MHz AWGN signal relative to the EUT's channel bandwidth and center frequency.
  6. Set the AWGN signal power to an extremely low level. Connect the AWGN signal source, via a 3-dB splitter, to the signal analyzer 1 and the EUT as shown in below figure.
  7. Transmit the AWGN signal (RF ON) and verify its characteristics on the signal analyzer 1.
  8. Monitor the signal analyzer 2 to verify if the AWGN signal has been detected and the EUT has ceased transmission. If the EUT continues to transmit, then incrementally increase the AWGN signal power level until the EUT stops transmitting.
-

9. Determine and record the AWGN signal power level (at the EUT's antenna port) at which the EUT ceased transmission. Repeat the procedure at least 10 times to verify the EUT can detect an AWGN signal with 90% (or better) level of certainty.

10. Refer to Table 1 to determine number of times the detection threshold testing needs to be repeated. If testing is required more than once, then go back to step 5, choose a different center frequency for the AWGN signal and repeat the process.

#### 6.7.4. Test Setup

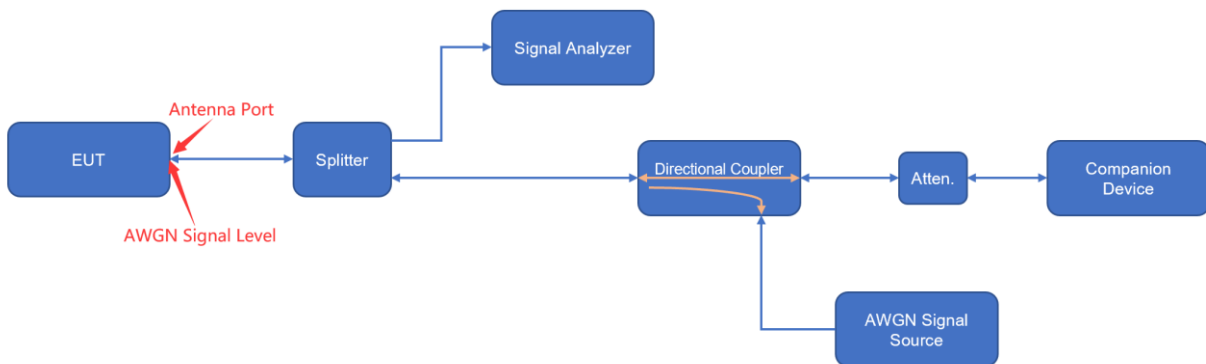

#### 6.7.5. Test Result

Refer to Appendix A.7.

**6.8. Radiated Spurious Emission Measurement**

**6.8.1. Test Limit**

For 15.407(b)(6) requirement

For transmitters operating within the 5.925-7.125 GHz band: Any emissions outside of the 5.925-7.125 GHz band must not exceed an e.i.r.p. of -27 dBm/MHz.

Refer to 987594 D02 U-NII 6GHz EMC Measurement v01 clause G

Use guidance in KDB 789033 for measurements below 1000 MHz and above 1000 MHz. Unwanted emissions outside of restricted bands are measured with a RMS detector. In addition, 15.35(b) applies where the peak emissions must be limited to no more than 20 dB above the average limit.

All out of band emissions appearing in a restricted band as specified in Section 15.205 of the Title 47CFR must not exceed the limits shown in Table per Section 15.209.

FCC Part 15 Subpart C Paragraph 15.209		
Frequency [MHz]	Field Strength [uV/m]	Measured Distance [Meters]
0.009 - 0.490	2400/F (kHz)	300
0.490 - 1.705	24000/F (kHz)	30
1.705 - 30	30	30
30 - 88	100	3
88 - 216	150	3
216 - 960	200	3
Above 960	500	3

**6.8.2. Test Procedure**

KDB 789033 D02v02r01-Section II)G)

**6.8.3. Test Setting**

**Table 1 - RBW as a function of frequency**

Frequency	RBW
9 ~ 150 kHz	200 ~ 300 Hz
0.15 ~ 30 MHz	9 ~ 10 kHz
30 ~ 1000 MHz	100 ~ 120 kHz
> 1000MHz	1MHz

**Quasi-Peak Measurements below 1GHz**

1. Analyzer center frequency was set to the frequency of the radiated spurious emission of interest
2. Span was set greater than 1MHz
3. RBW = as specified in Table 1
4. Detector = CISPR quasi-peak
5. Sweep time = auto couple
6. Trace was allowed to stabilize

**Peak Measurements above 1GHz**

1. Analyzer center frequency was set to the frequency of the radiated spurious emission of interest
2. RBW = 1MHz
3. VBW = 3MHz
4. Detector = peak
5. Sweep time = auto couple
6. Trace mode = max hold
7. Trace was allowed to stabilize

**Average Measurements above 1GHz (Method VB)**

1. Analyzer center frequency was set to the frequency of the radiated spurious emission of interest
2. RBW = 1MHz
3. VBW; If the EUT is configured to transmit with duty cycle  $\geq 98\%$ , set VBW = 10 Hz.  
If the EUT duty cycle is  $< 98\%$ , set VBW  $\geq 1/T$ . T is the minimum transmission duration.
4. Detector = Peak
5. Sweep time = auto
6. Trace mode = max hold
7. Trace was allowed to stabilize

### 6.8.4. Test Setup

Below 1GHz Test Setup:

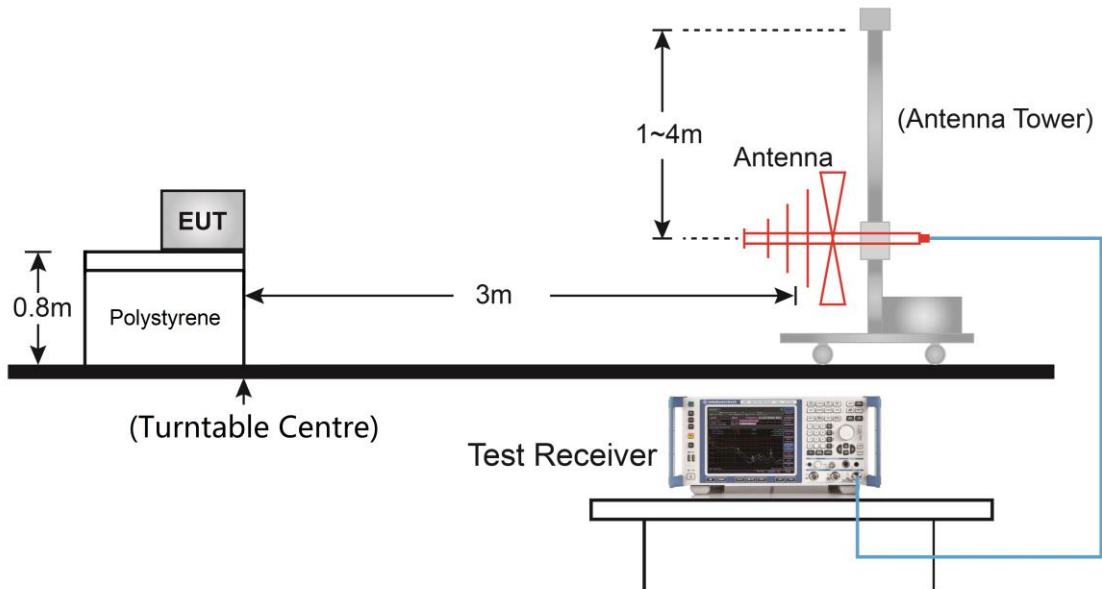

Above 1GHz Test Setup:

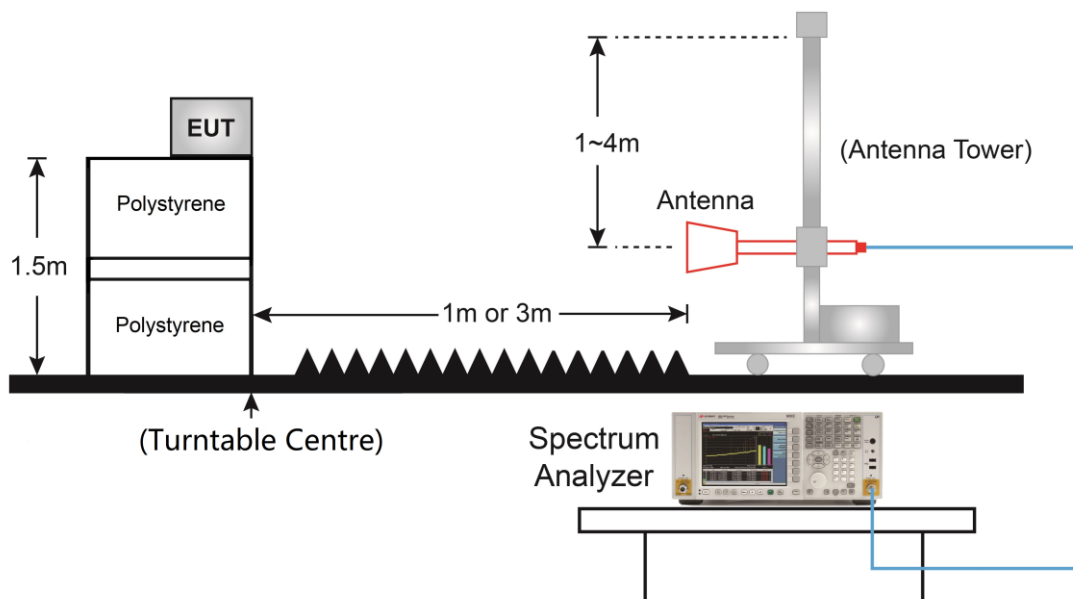

### 6.8.5. Test Result

Refer to Appendix A.8.

## 6.9. Radiated Restricted Band Edge Measurement

### 6.9.1. Test Limit

#### For 15.205 requirement:

Radiated emissions which fall in the restricted bands, as defined in Section 15.205(a) of FCC part 15, must also comply with the radiated emission limits specified in Section 15.209(a).

Frequency (MHz)	Frequency (MHz)	Frequency (MHz)	Frequency (GHz)
0.090 - 0.110	16.42 - 16.423	399.9 - 410	4.5 - 5.15
<sup>1</sup> 0.495 - 0.505	16.69475 - 16.69525	608 - 614	5.35 - 5.46
2.1735 - 2.1905	16.80425 - 16.80475	960 - 1240	7.25 - 7.75
4.125 - 4.128	25.5 - 25.67	1300 - 1427	8.025 - 8.5
4.17725 - 4.17775	37.5 - 38.25	1435 - 1626.5	9.0 - 9.2
4.20725 - 4.20775	73 - 74.6	1645.5 - 1646.5	9.3 - 9.5
6.215 - 6.218	74.8 - 75.2	1660 - 1710	10.6 - 12.7
6.26775 - 6.26825	108 - 121.94	1718.8 - 1722.2	13.25 - 13.4
6.31175 - 6.31225	123 - 138	2200 - 2300	14.47 - 14.5
8.291 - 8.294	149.9 - 150.05	2310 - 2390	15.35 - 16.2
8.362 - 8.366	156.52475 - 156.52525	2483.5 - 2500	17.7 - 21.4
8.37625 - 8.38675	156.7 - 156.9	2690 - 2900	22.01 - 23.12
8.41425 - 8.41475	162.0125 - 167.17	3260 - 3267	23.6 - 24.0
12.29 - 12.293	167.72 - 173.2	3332 - 3339	31.2 - 31.8
12.51975 - 12.52025	240 - 285	3345.8 - 3358	36.43 - 36.5
12.57675 - 12.57725	322 - 335.4	3600 - 4400	( <sup>2</sup> )
13.36 - 13.41	--	--	--

#### For 15.407(b)(6) requirement

For transmitters operating within the 5.925-7.125 GHz band: Any emissions outside of the 5.925-7.125 GHz band must not exceed an e.i.r.p. of -27 dBm/MHz.

#### Refer to 987594 D02 U-NII 6GHz EMC Measurement v01 clause G - Unwanted Emission Measurement

Use guidance in KDB 789033 for measurements below 1000 MHz and above 1000 MHz. Unwanted emissions outside of restricted bands are measured with a RMS detector. In addition, 15.35(b) applies where the peak emissions must be limited to no more than 20 dB above the average limit.



All out of band emissions appearing in a restricted band as specified in Section 15.205 of the Title 47CFR must not exceed the limits shown in Table per Section 15.209.

FCC Part 15 Subpart C Paragraph 15.209		
Frequency [MHz]	Field Strength [uV/m]	Measured Distance [Meters]
0.009 - 0.490	2400/F (kHz)	300
0.490 - 1.705	24000/F (kHz)	30
1.705 - 30	30	30
30 - 88	100	3
88 - 216	150	3
216 - 960	200	3
Above 960	500	3

### 6.9.2. Test Procedure

KDB 789033 D02v02r01-Section II)G)

### 6.9.3. Test Setting

#### Peak Measurements above 1GHz

1. Analyzer center frequency was set to the frequency of the radiated spurious emission of interest
2. RBW = 1MHz
3. VBW = 3MHz
4. Detector = Peak
5. Sweep time = Auto couple
6. Trace mode = Max hold
7. Trace was allowed to stabilize

### Average Measurements above 1GHz (Method VB)

1. Analyzer center frequency was set to the frequency of the radiated spurious emission of interest
2. RBW = 1MHz
3. VBW; if the EUT is configured to transmit with duty cycle  $\geq 98\%$ , set VBW = 10Hz
4. If the EUT duty cycle is  $< 98\%$ , set VBW  $\geq 1/T$ . T is the minimum transmission duration
5. Detector = Peak
6. Sweep time = Auto
7. Trace mode = Max hold
8. Trace was allowed to stabilize

#### 6.9.4. Test Setup

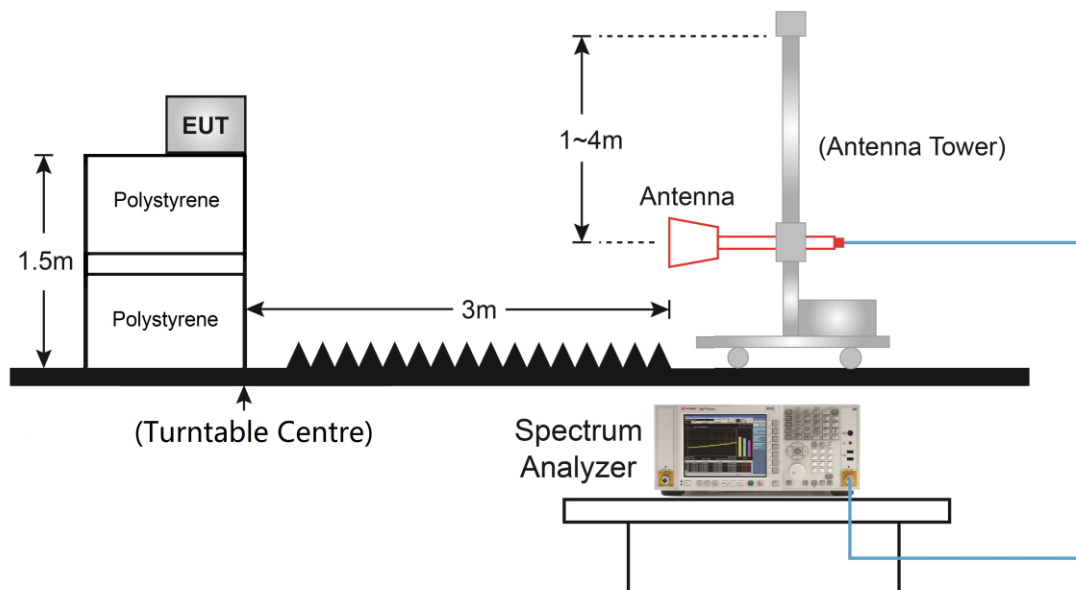

#### 6.9.5. Test Result

Refer to Appendix A.9.

## 6.10. AC Conducted Emissions Measurement

### 6.10.1. Test Limit

FCC Part 15.207 Limits		
Frequency (MHz)	QP (dBuV)	AV (dBuV)
0.15 - 0.50	66 - 56	56 - 46
0.50 - 5.0	56	46
5.0 - 30	60	50

Note 1: The lower limit shall apply at the transition frequencies.

Note 2: The limit decreases linearly with the logarithm of the frequency in the range 0.15MHz to 0.5MHz.

### 6.10.2. Test Setup

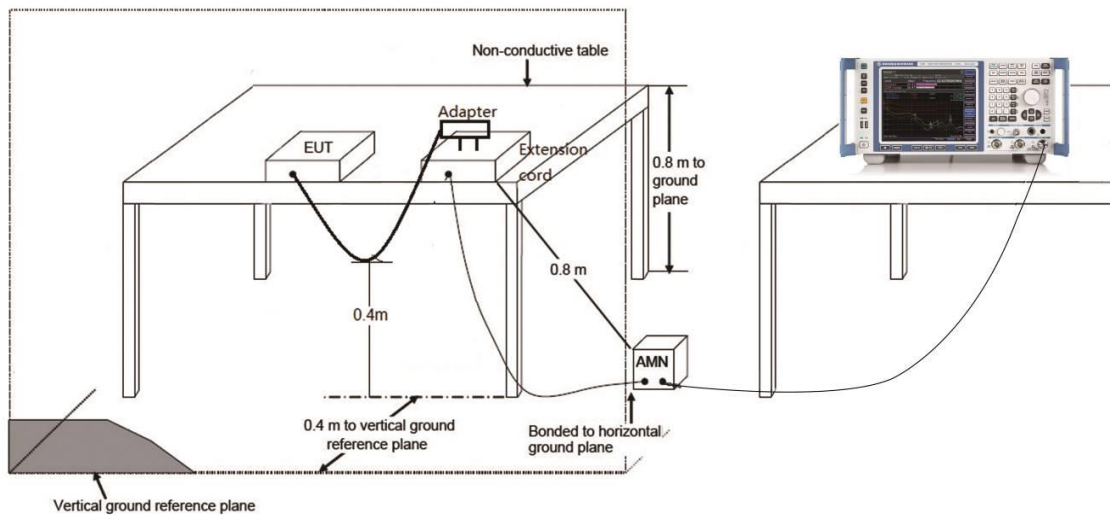

### 6.10.3. Test Result

Refer to Appendix A.10.

## Appendix A - Test Result

### A.1 Duty Cycle Test Result

Test Site	WZ-SR5	Test Engineer	Luis Yang
Test Date	2021/12/11 ~ 2022/01/27		

Test Mode	Duty Cycle
802.11a	93.21%
802.11ax-HE20	93.73%
802.11ax-HE40	93.98%
802.11ax-HE80	93.55%
802.11ax-HE160	92.91%

#### Duty Cycle (T = Transmission Duration)

802.11a (T = 1.976ms)	802.11ax-HE20 (T = 5.427ms)
<p>802.11a (T = 1.976ms)</p>	<p>802.11ax-HE20 (T = 5.427ms)</p>
<p>802.11ax-HE40 (T = 5.430ms)</p>	<p>802.11ax-HE80 (T = 5.452ms)</p>

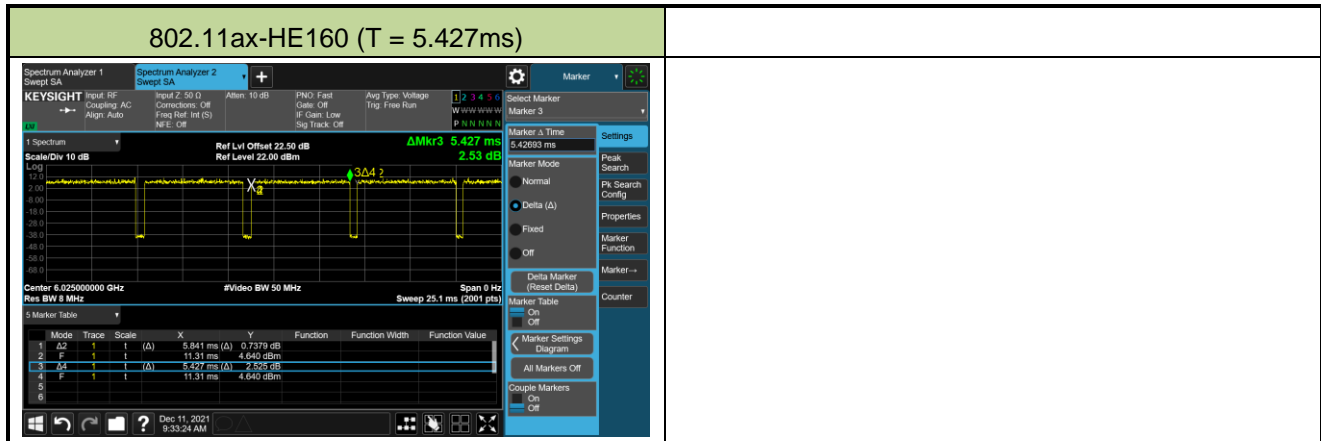

**A.2 26dB & 99% Bandwidth Test Result**

Test Site	WZ-SR5	Test Engineer	Luis Yang
Test Date	2022/01/11		

Test Mode	Data Rate/ MCS	Channel No.	Frequency (MHz)	26dB Bandwidth (MHz)	99% Bandwidth (MHz)
802.11a	6Mbps	01	5955	19.87	16.525
802.11a	6Mbps	49	6195	19.92	16.524
802.11a	6Mbps	93	6415	20.39	16.529
802.11a	6Mbps	97	6435	19.78	16.513
802.11a	6Mbps	105	6475	20.49	16.527
802.11a	6Mbps	113	6515	20.04	16.515
802.11a	6Mbps	117	6535	20.02	16.513
802.11a	6Mbps	153	6715	20.41	16.532
802.11a	6Mbps	181	6855	20.41	16.528
802.11a	6Mbps	185	6875	19.97	16.524
802.11a	6Mbps	189	6895	19.77	16.540
802.11a	6Mbps	213	7015	19.90	16.521
802.11a	6Mbps	229	7095	19.83	16.535
802.11ax-HE20	MCS0	01	5955	21.62	19.097
802.11ax-HE20	MCS0	49	6195	21.61	19.081
802.11ax-HE20	MCS0	93	6415	21.88	19.110
802.11ax-HE20	MCS0	97	6435	21.71	19.067
802.11ax-HE20	MCS0	105	6475	21.70	19.061
802.11ax-HE20	MCS0	113	6515	21.63	19.074
802.11ax-HE20	MCS0	117	6535	21.64	19.070
802.11ax-HE20	MCS0	153	6715	21.69	19.086
802.11ax-HE20	MCS0	181	6855	21.25	19.086
802.11ax-HE20	MCS0	185	6875	21.27	19.069
802.11ax-HE20	MCS0	189	6895	21.66	19.088
802.11ax-HE20	MCS0	213	7015	21.32	19.071
802.11ax-HE20	MCS0	229	7095	21.72	19.092

Test Mode	Data Rate/ MCS	Channel No.	Frequency (MHz)	26dB Bandwidth (MHz)	99% Bandwidth (MHz)
802.11ax-HE40	MCS0	03	5965	40.15	37.657
802.11ax-HE40	MCS0	51	6205	40.19	37.599
802.11ax-HE40	MCS0	91	6405	40.06	37.624
802.11ax-HE40	MCS0	99	6445	40.09	37.622
802.11ax-HE40	MCS0	107	6485	40.18	37.646
802.11ax-HE40	MCS0	115	6525	40.26	37.648
802.11ax-HE40	MCS0	123	6565	40.24	37.592
802.11ax-HE40	MCS0	147	6685	40.17	37.693
802.11ax-HE40	MCS0	179	6845	39.93	37.577
802.11ax-HE40	MCS0	187	6885	40.37	37.599
802.11ax-HE40	MCS0	195	6925	40.00	37.654
802.11ax-HE40	MCS0	211	7005	40.00	37.567
802.11ax-HE40	MCS0	227	7085	40.03	37.598
802.11ax-HE80	MCS0	07	5985	81.17	77.064
802.11ax-HE80	MCS0	55	6225	81.49	77.075
802.11ax-HE80	MCS0	87	6385	81.55	77.082
802.11ax-HE80	MCS0	103	6465	81.61	77.057
802.11ax-HE80	MCS0	119	6545	81.66	77.017
802.11ax-HE80	MCS0	135	6625	81.12	77.097
802.11ax-HE80	MCS0	151	6705	81.43	77.027
802.11ax-HE80	MCS0	183	6865	81.26	77.042
802.11ax-HE80	MCS0	199	6945	81.97	77.066
802.11ax-HE80	MCS0	215	7025	81.76	76.988
802.11ax-HE160	MCS0	15	6025	162.4	154.98
802.11ax-HE160	MCS0	47	6185	162.9	154.80
802.11ax-HE160	MCS0	79	6345	162.5	154.89
802.11ax-HE160	MCS0	111	6505	163.7	154.59
802.11ax-HE160	MCS0	143	6665	163.4	154.86
802.11ax-HE160	MCS0	175	6825	162.2	154.79
802.11ax-HE160	MCS0	207	6985	163.5	154.75

802.11a 26dB Bandwidth

Channel 01 (5955MHz)

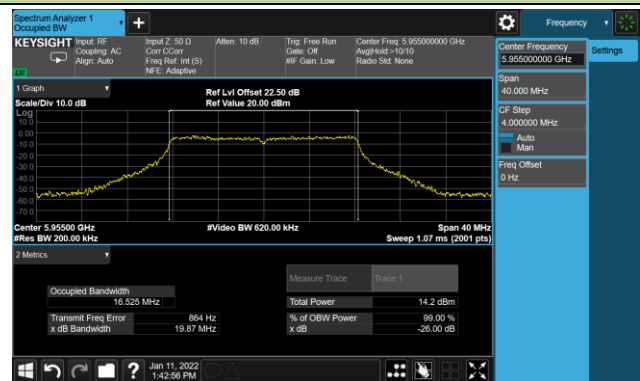

Channel 49 (6195MHz)

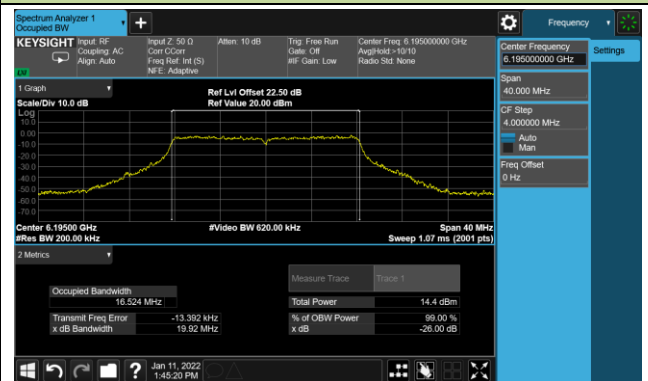

Channel 93 (6415MHz)

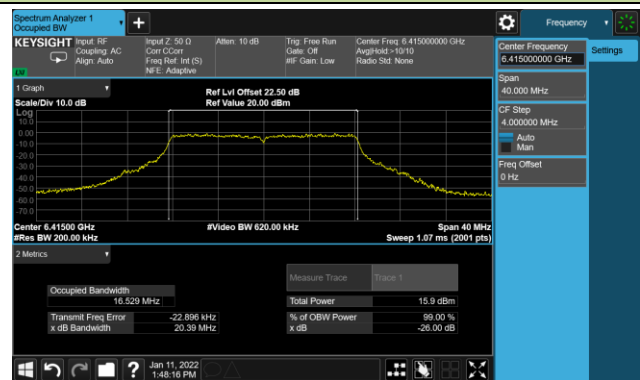

Channel 97 (6435MHz)

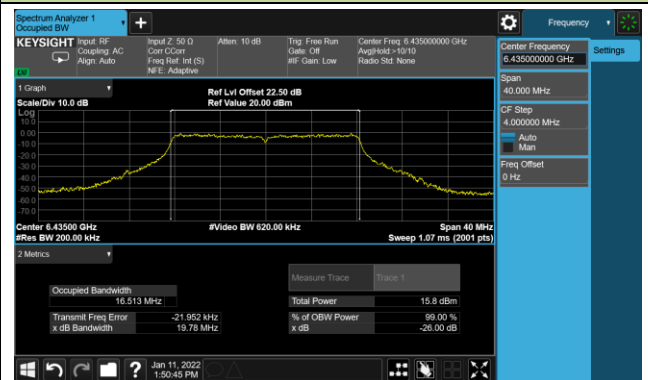

Channel 105 (6475MHz)

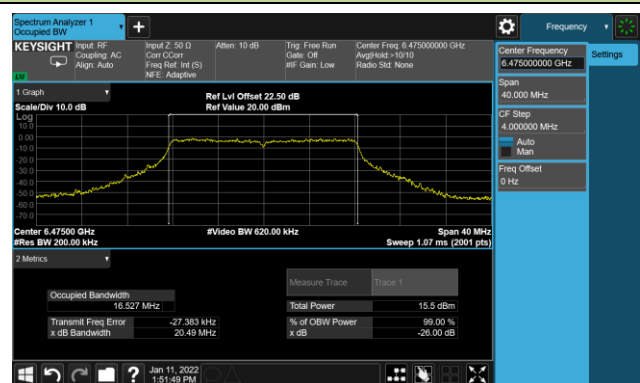

Channel 113 (6515MHz)





802.11a 26dB Bandwidth

Channel 117 (6535MHz)

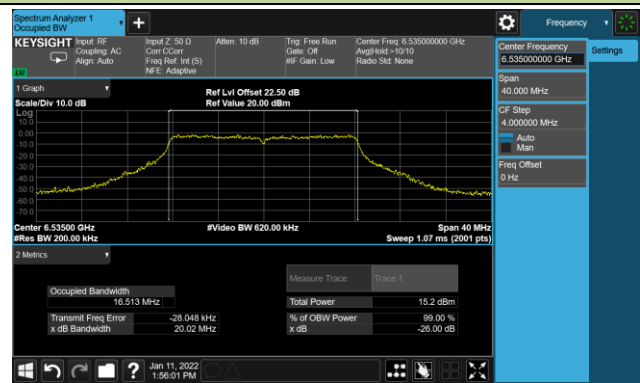

Channel 153 (6715MHz)

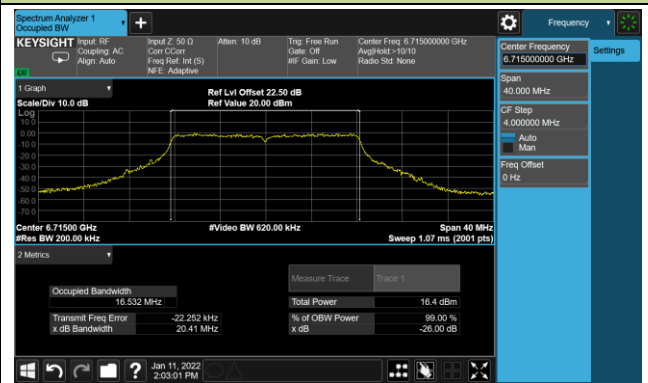

Channel 181 (6855MHz)

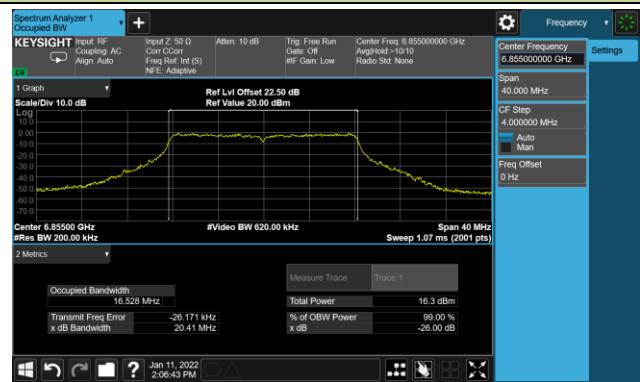

Channel 185 (6875MHz)

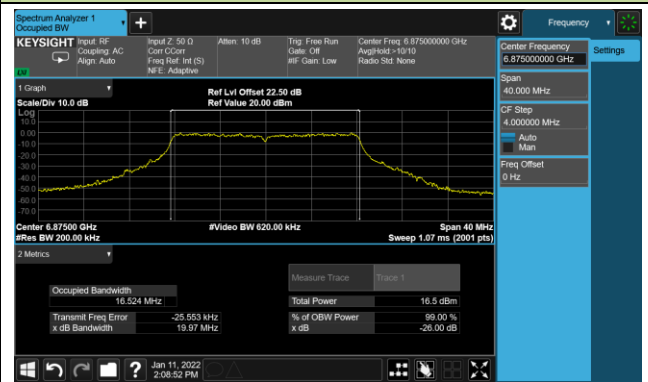

Channel 189 (6895MHz)

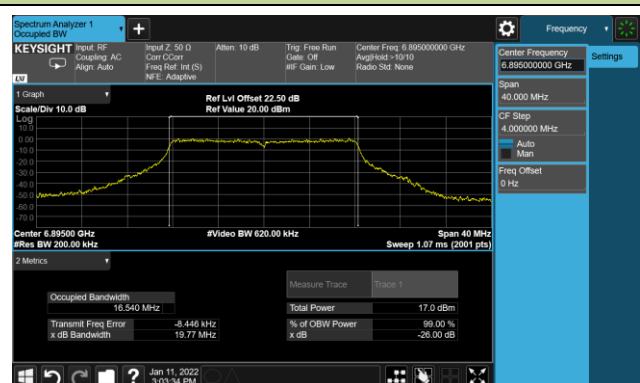

Channel 213 (7015MHz)

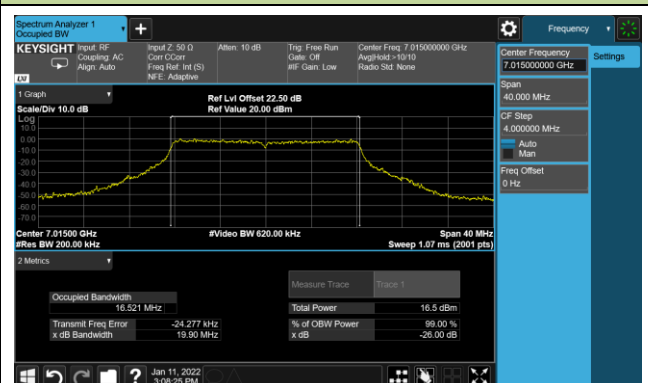

Channel 229 (7095MHz)



## 802.11ax-HE20 26dB Bandwidth

## Channel 01 (5955MHz)

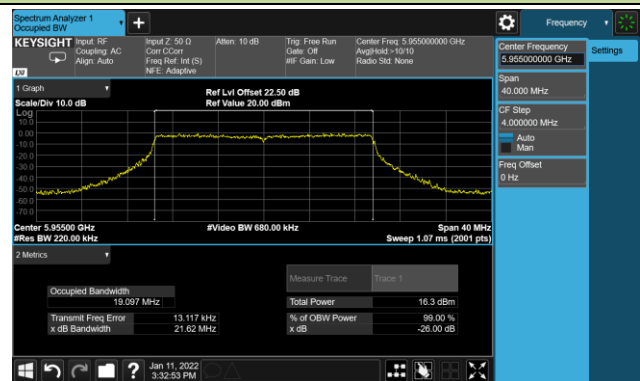

## Channel 49 (6195MHz)

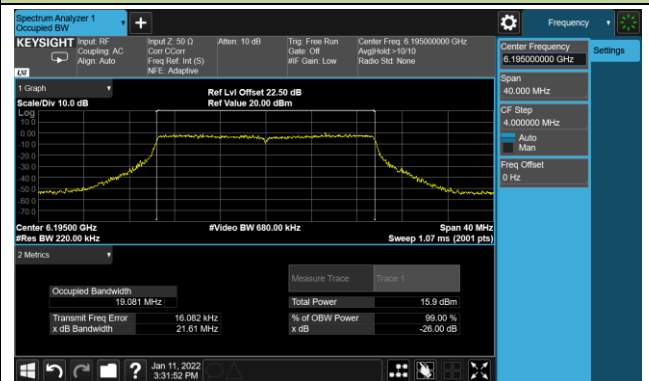

## Channel 93 (6415MHz)

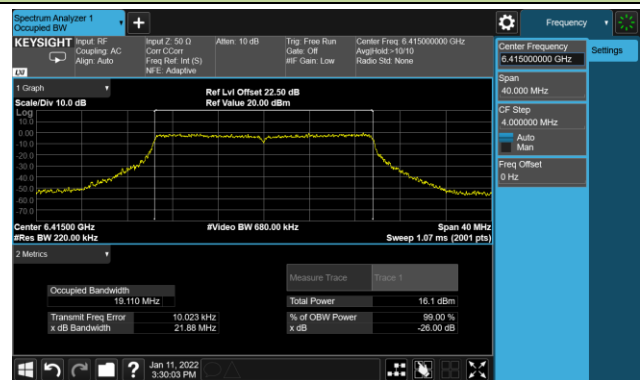

## Channel 97 (6435MHz)

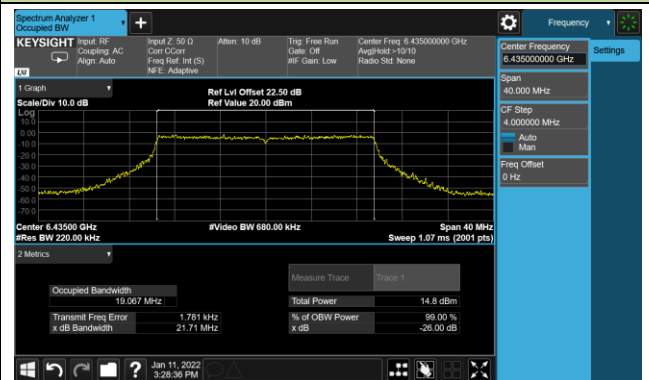

## Channel 105 (6475MHz)

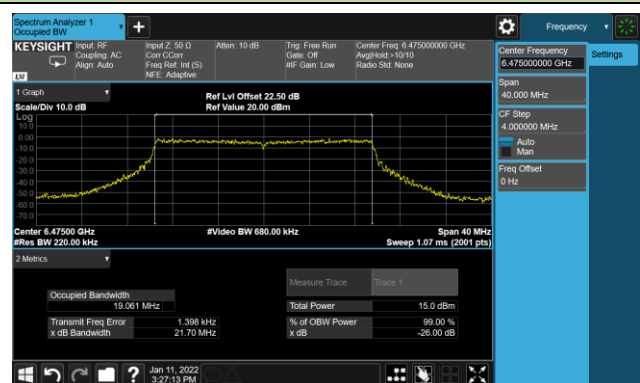

## Channel 113 (6515MHz)

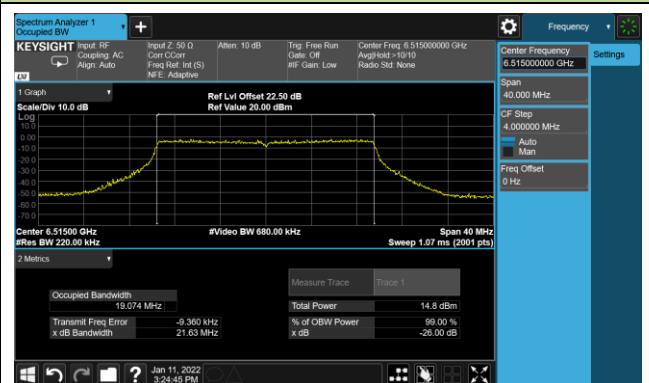

802.11ax-HE20 26dB Bandwidth

Channel 117 (6535MHz)

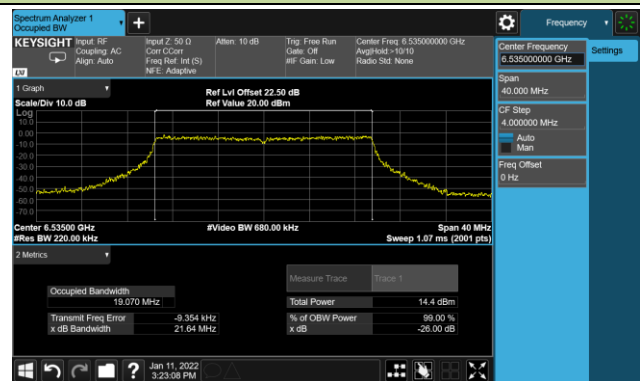

Channel 153 (6715MHz)

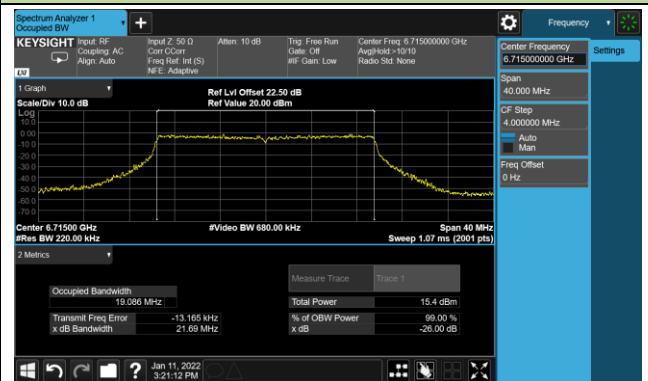

Channel 181 (6855MHz)

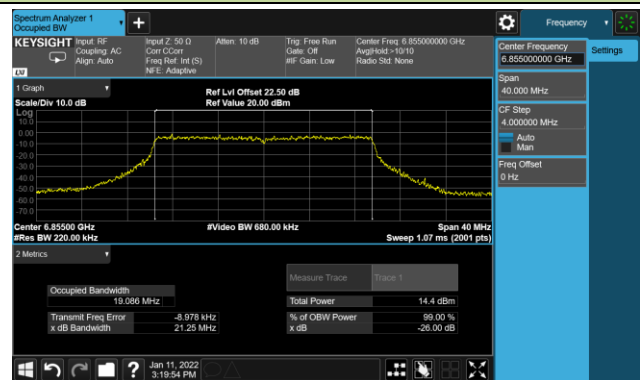

Channel 185 (6875MHz)

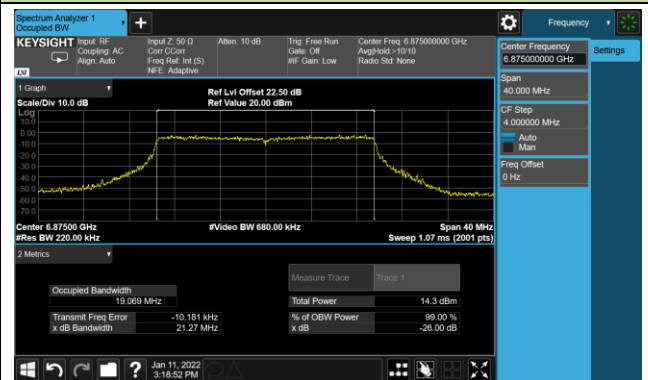

Channel 189 (6895MHz)

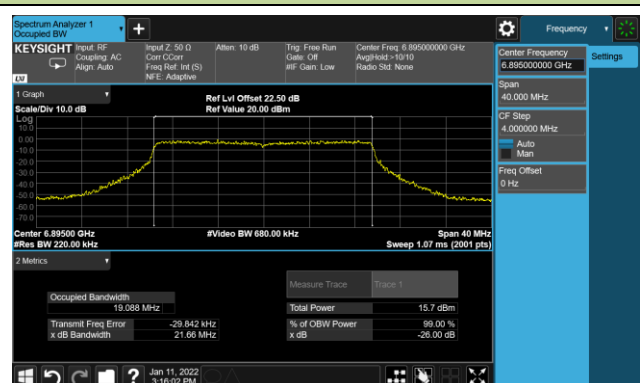

Channel 213 (7015MHz)



Channel 229 (7095MHz)

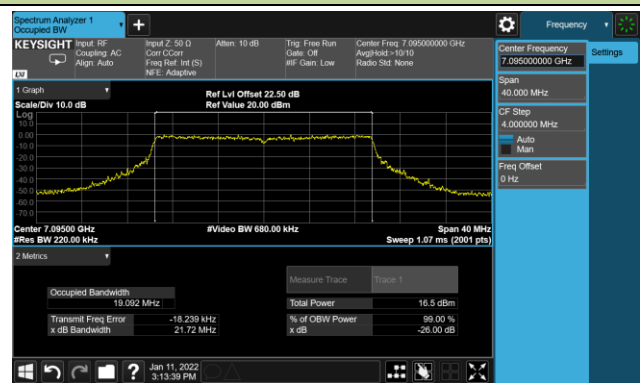

802.11ax-HE40 26dB Bandwidth

Channel 03 (5965MHz)

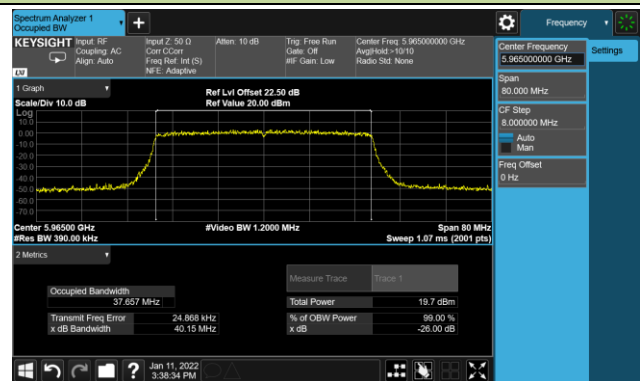

Channel 51 (6205MHz)

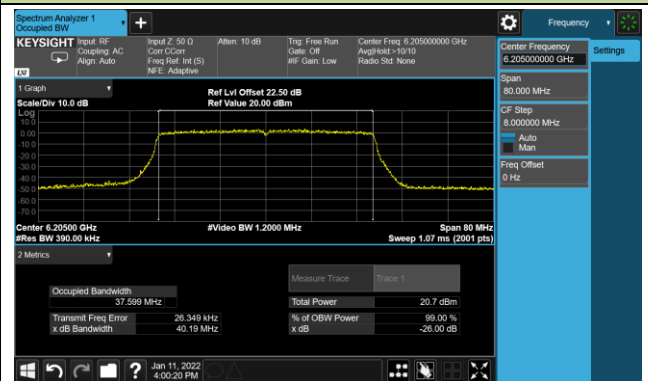

Channel 91 (6405MHz)

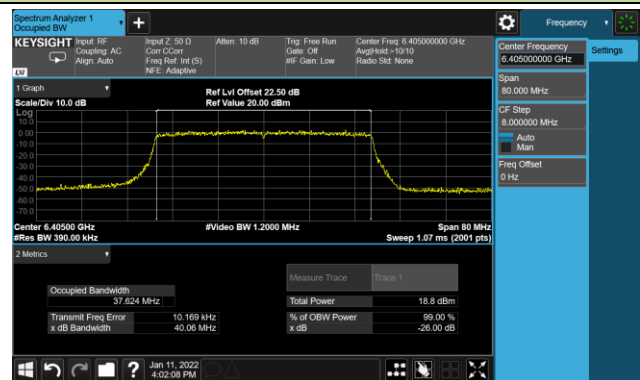

Channel 99 (6445MHz)

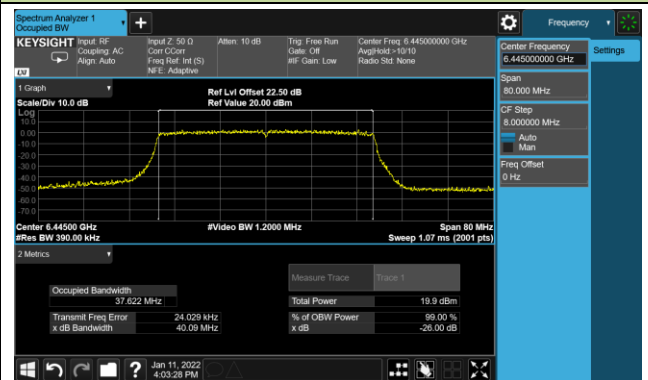

Channel 107 (6485MHz)

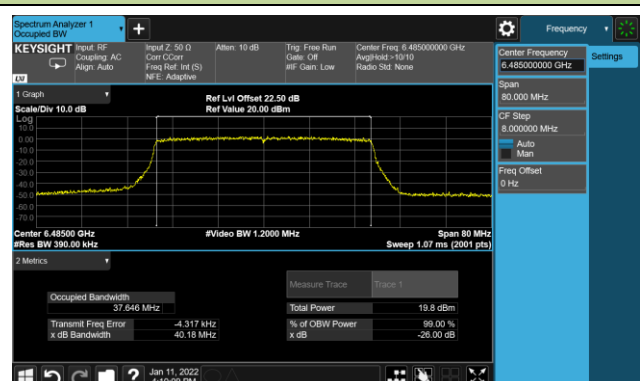

Channel 115 (6525MHz)

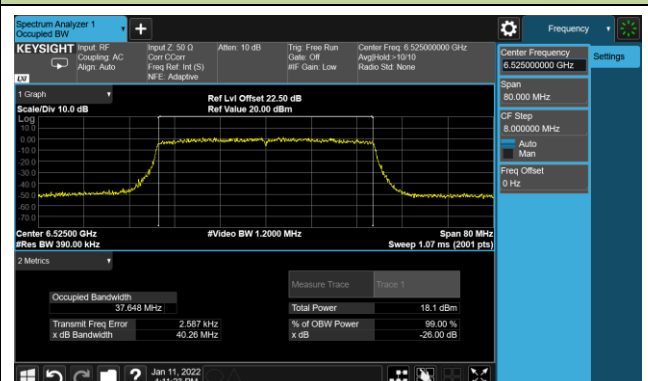

## 802.11ax-HE40 26dB Bandwidth

## Channel 123 (6565MHz)

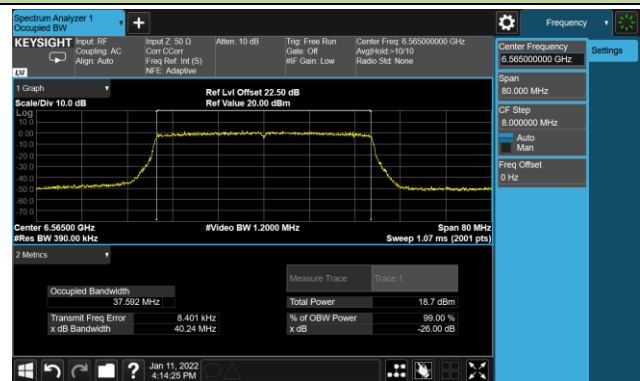

## Channel 147 (6685MHz)

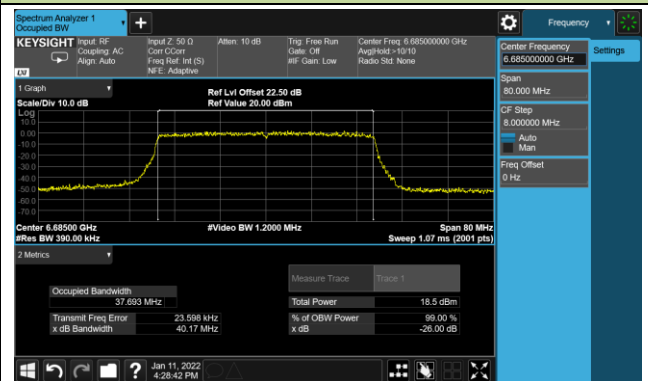

## Channel 179 (6845MHz)

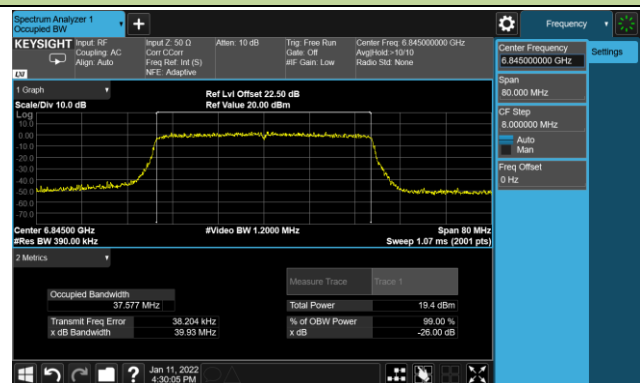

## Channel 187 (6885MHz)

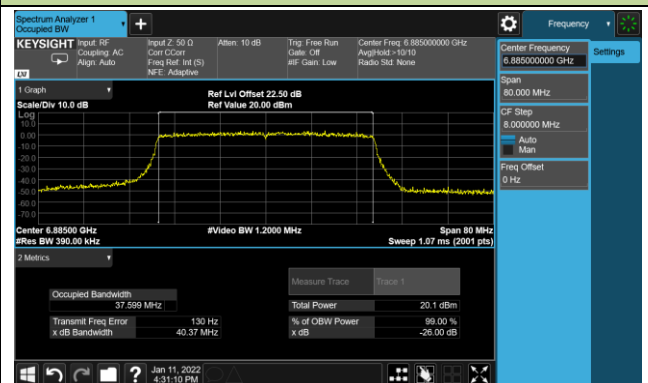

## Channel 195 (6925MHz)

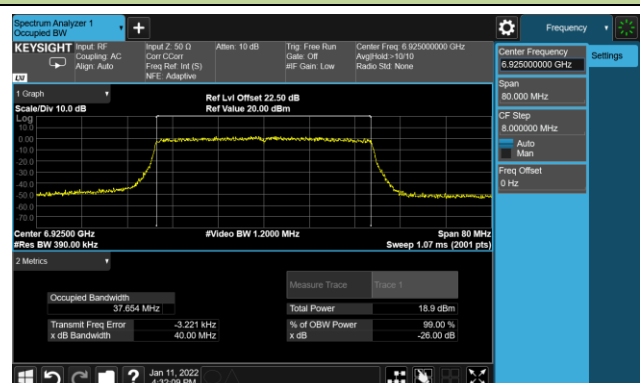

## Channel 211 (7005MHz)

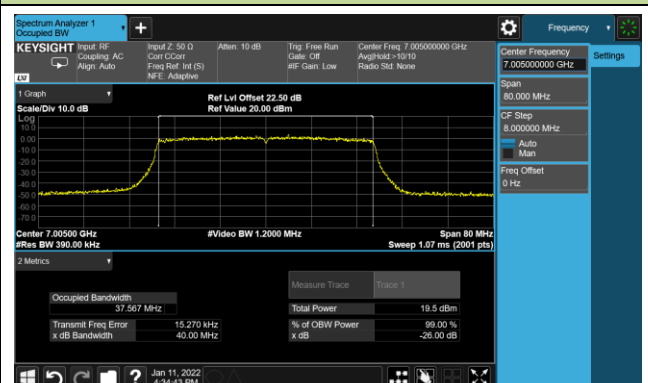

## Channel 227 (7085MHz)

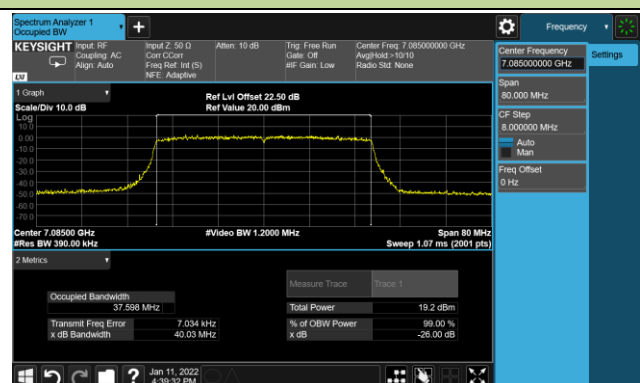

802.11ax-HE80 26dB Bandwidth

Channel 07 (5985MHz)

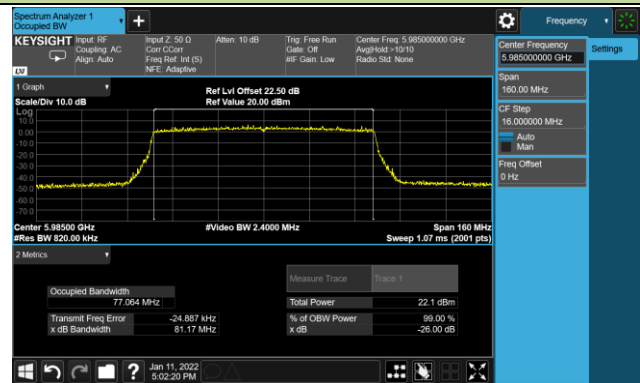

Channel 55 (6225MHz)

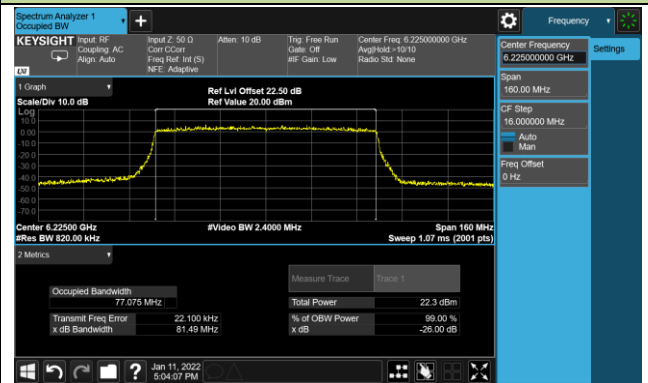

Channel 87 (6385MHz)

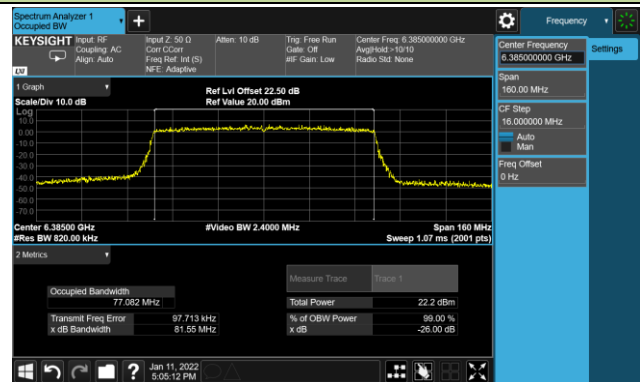

Channel 103 (6465MHz)

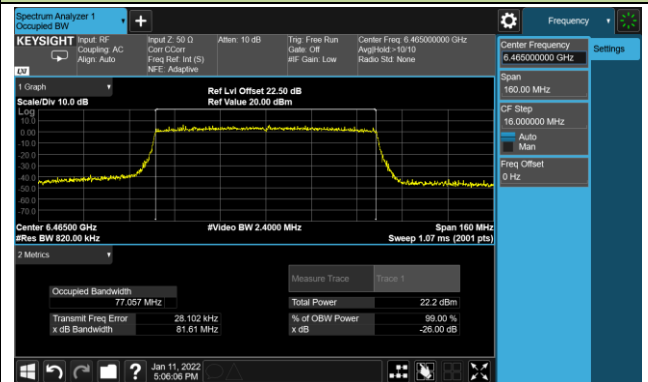

Channel 119 (6545MHz)

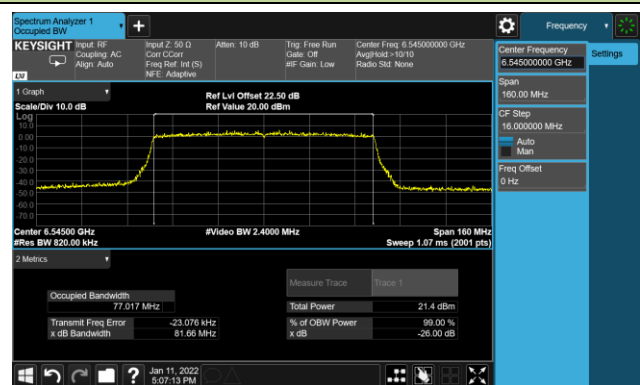

Channel 135 (6625MHz)

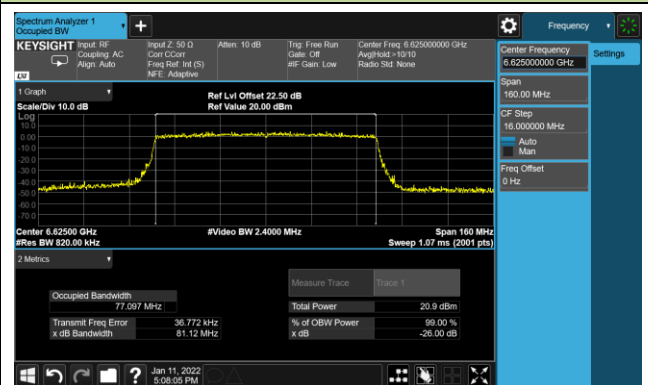

802.11ax-HE80 26dB Bandwidth

Channel 151 (6705MHz)

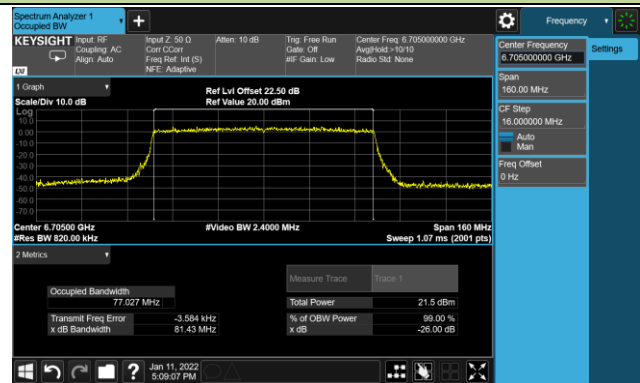

Channel 183 (6865MHz)

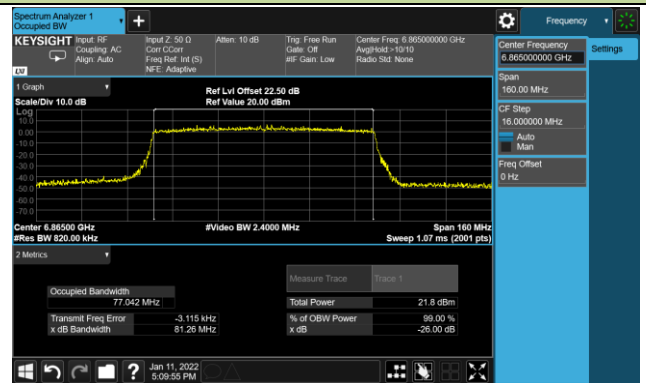

Channel 199 (6945MHz)

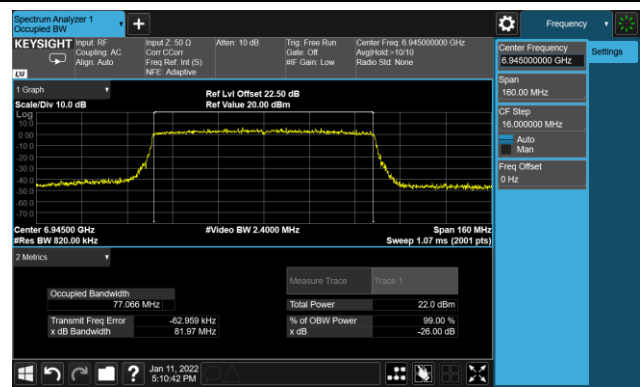

Channel 215 (7025MHz)

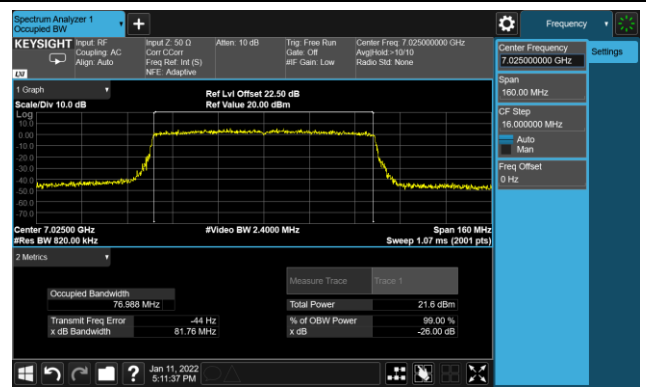

## 802.11ax-HE160 26dB Bandwidth

## Channel 15 (6025MHz)

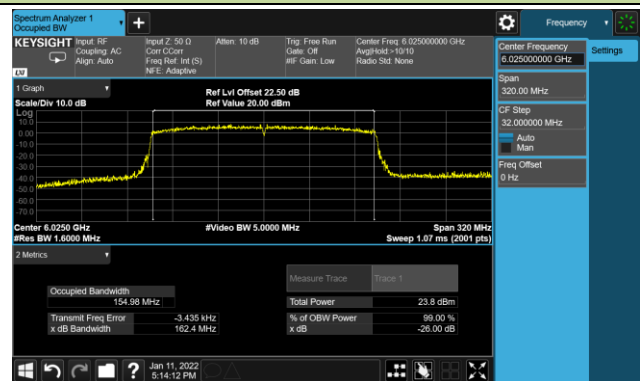

## Channel 47 (6185MHz)

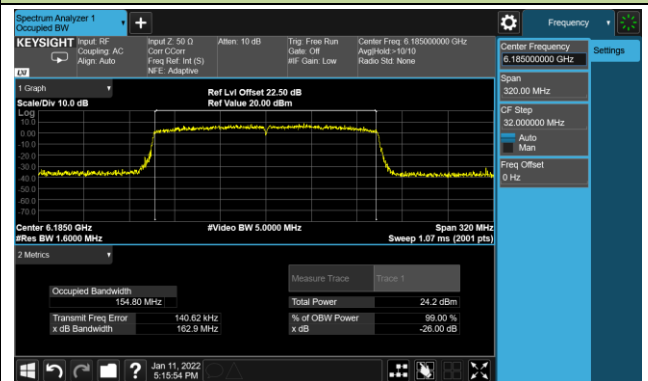

## Channel 79 (6345MHz)

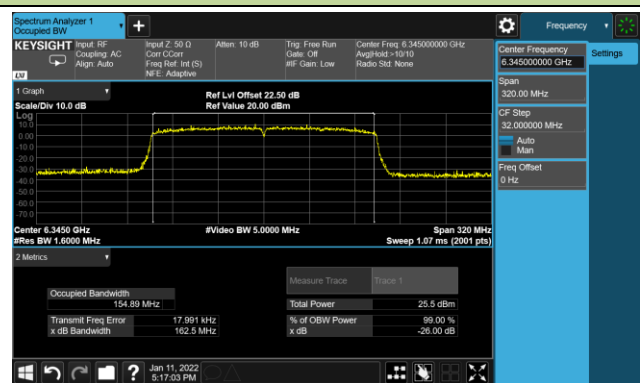

## Channel 111 (6505MHz)

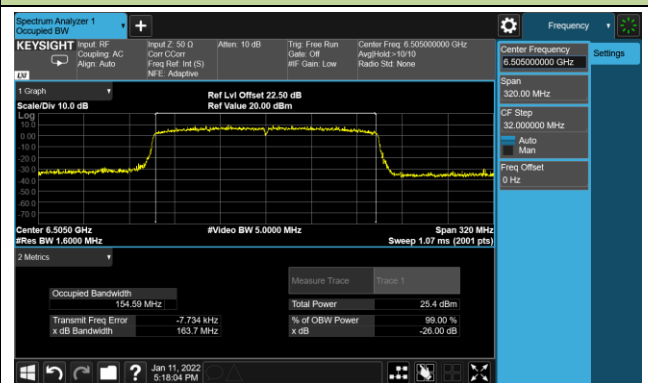

## Channel 143 (6665MHz)

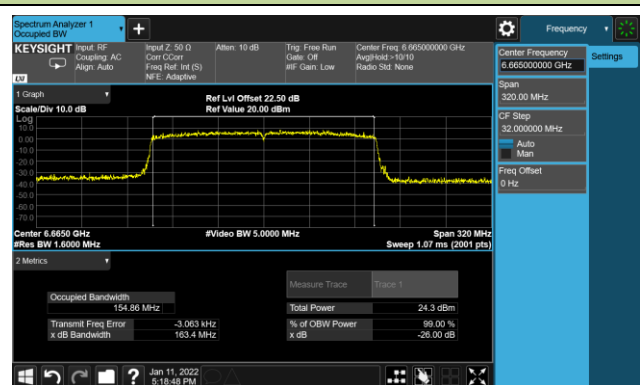

## Channel 175 (6825MHz)

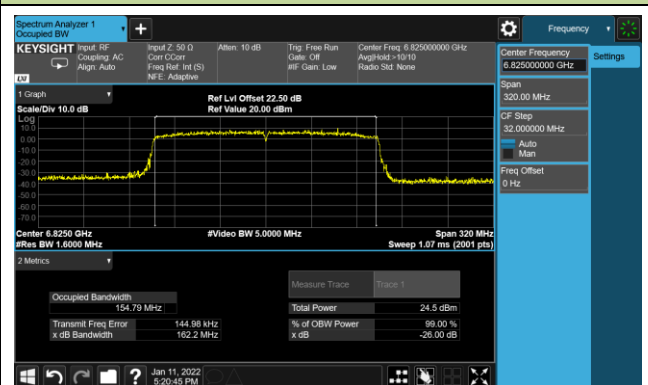

## Channel 207 (6985MHz)

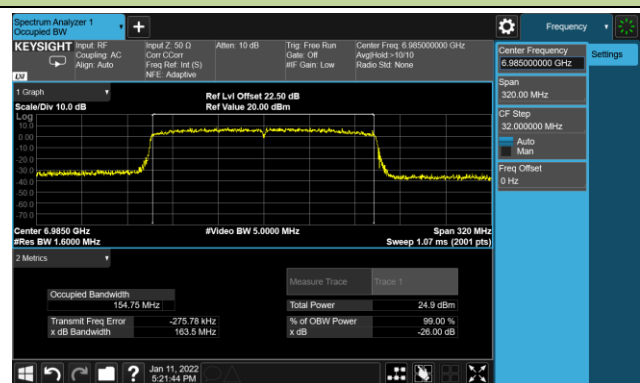



### A.3 Output Power Test Result

Test Site	WZ-AC2	Test Engineer	Tommy Tang
Test Date	2022/01/10		

Test Mode	Data Rate/ MCS	Channel No.	Freq. (MHz)	EIRP (dB $\mu$ V/m)	EIRP (dBm)	Total EIRP (dBm)	E.I.R.P Limit (dBm)
802.11a	6Mbps	01	5955	110.2	15.000	15.305	≤ 30.00
802.11a	6Mbps	49	6195	109.9	14.700	15.005	≤ 30.00
802.11a	6Mbps	93	6415	110.5	15.300	15.605	≤ 30.00
802.11a	6Mbps	97	6435	109.7	14.500	14.805	≤ 30.00
802.11a	6Mbps	105	6475	109.7	14.500	14.805	≤ 30.00
802.11a	6Mbps	113	6515	109.8	14.600	14.905	≤ 30.00
802.11a	6Mbps	117	6535	109.7	14.500	14.805	≤ 30.00
802.11a	6Mbps	153	6715	110.7	15.500	15.805	≤ 30.00
802.11a	6Mbps	181	6855	110.0	14.800	15.105	≤ 30.00
802.11a	6Mbps	185	6875	109.9	14.700	15.005	≤ 30.00
802.11a	6Mbps	189	6895	110.3	15.100	15.405	≤ 30.00
802.11a	6Mbps	213	7015	110.2	15.000	15.305	≤ 30.00
802.11a	6Mbps	229	7095	110.4	15.200	15.505	≤ 30.00
802.11ax-HE20	MCS0	01	5955	109.4	14.200	14.481	≤ 30.00
802.11ax-HE20	MCS0	49	6195	109.4	14.200	14.481	≤ 30.00
802.11ax-HE20	MCS0	93	6415	109.7	14.500	14.781	≤ 30.00
802.11ax-HE20	MCS0	97	6435	109.7	14.500	14.781	≤ 30.00
802.11ax-HE20	MCS0	105	6475	109.4	14.200	14.481	≤ 30.00
802.11ax-HE20	MCS0	113	6515	109.2	14.000	14.281	≤ 30.00
802.11ax-HE20	MCS0	117	6535	109.8	14.600	14.881	≤ 30.00
802.11ax-HE20	MCS0	153	6715	109.2	14.000	14.281	≤ 30.00
802.11ax-HE20	MCS0	181	6855	108.6	13.400	13.681	≤ 30.00
802.11ax-HE20	MCS0	185	6875	107.9	12.700	12.981	≤ 30.00
802.11ax-HE20	MCS0	189	6895	108.3	13.100	13.381	≤ 30.00
802.11ax-HE20	MCS0	213	7015	108.7	13.500	13.781	≤ 30.00
802.11ax-HE20	MCS0	229	7095	109.2	14.000	14.281	≤ 30.00

Test Mode	Data Rate/ MCS	Channel No.	Freq. (MHz)	EIRP (dBμV/m)	EIRP (dBm)	Total EIRP (dBm)	E.I.R.P Limit (dBm)
802.11ax-HE40	MCS0	03	5965	111.1	15.900	16.170	≤ 30.00
802.11ax-HE40	MCS0	51	6205	112.4	17.200	17.470	≤ 30.00
802.11ax-HE40	MCS0	91	6405	111.4	16.200	16.470	≤ 30.00
802.11ax-HE40	MCS0	99	6445	111.8	16.600	16.870	≤ 30.00
802.11ax-HE40	MCS0	107	6485	111.9	16.700	16.970	≤ 30.00
802.11ax-HE40	MCS0	115	6525	111.9	16.700	16.970	≤ 30.00
802.11ax-HE40	MCS0	123	6565	111.7	16.500	16.770	≤ 30.00
802.11ax-HE40	MCS0	147	6685	111.9	16.700	16.970	≤ 30.00
802.11ax-HE40	MCS0	179	6845	112.3	17.100	17.370	≤ 30.00
802.11ax-HE40	MCS0	187	6885	112.5	17.300	17.570	≤ 30.00
802.11ax-HE40	MCS0	195	6925	112.0	16.800	17.070	≤ 30.00
802.11ax-HE40	MCS0	211	7005	111.9	16.700	16.970	≤ 30.00
802.11ax-HE40	MCS0	227	7085	111.9	16.700	16.970	≤ 30.00
802.11ax-HE80	MCS0	07	5985	115.1	19.900	20.190	≤ 30.00
802.11ax-HE80	MCS0	55	6225	115.3	20.100	20.390	≤ 30.00
802.11ax-HE80	MCS0	87	6385	115.2	20.000	20.290	≤ 30.00
802.11ax-HE80	MCS0	103	6465	114.6	19.400	19.690	≤ 30.00
802.11ax-HE80	MCS0	119	6545	114.8	19.600	19.890	≤ 30.00
802.11ax-HE80	MCS0	135	6625	115.1	19.900	20.190	≤ 30.00
802.11ax-HE80	MCS0	151	6705	114.9	19.700	19.990	≤ 30.00
802.11ax-HE80	MCS0	183	6865	115.1	19.900	20.190	≤ 30.00
802.11ax-HE80	MCS0	199	6945	115.2	20.000	20.290	≤ 30.00
802.11ax-HE80	MCS0	215	7025	115.3	20.100	20.390	≤ 30.00
802.11ax-HE160	MCS0	15	6025	117.6	22.400	22.719	≤ 30.00
802.11ax-HE160	MCS0	47	6185	118.1	22.900	23.219	≤ 30.00
802.11ax-HE160	MCS0	79	6345	118.4	23.200	23.519	≤ 30.00
802.11ax-HE160	MCS0	111	6505	118.2	23.000	23.319	≤ 30.00
802.11ax-HE160	MCS0	143	6665	117.5	22.300	22.619	≤ 30.00
802.11ax-HE160	MCS0	175	6825	118.2	23.000	23.319	≤ 30.00
802.11ax-HE160	MCS0	207	6985	117.7	22.500	22.819	≤ 30.00

Note 1:  $EIRP (dBm) = EIRP (dB\mu V/m) + \text{Correction Factor @ } 3m$ ,  $\text{Correction Factor @ } 3m = 20\log(D) - 104.7$ ;  
 where D is the measurement distance @3m = -95.2dB

Note 2: If Duty cycle < 98%,  $\text{Total EIRP (dBm)} = EIRP (dBm) + 10*\text{Log}(1/\text{Duty cycle})$ .

**A.4 Power Spectral Density Test Result**

Test Site	WZ-AC2	Test Engineer	Tommy Tang
Test Date	2022/01/05 ~ 2022/01/10		

Test Mode	Data Rate/MCS	Channel No.	Freq. (MHz)	EIRP PSD (dBμV/m/MHz)	EIRP PSD (dBm/MHz)	Duty Cycle (%)	Final EIRP PSD (dBm/MHz)	E.I.R.P PSD Limit (dBm/MHz)
802.11a	6Mbps	01	5955	99.855	4.655	93.21	4.960	≤ 5.00
802.11a	6Mbps	49	6195	99.675	4.475	93.21	4.780	≤ 5.00
802.11a	6Mbps	93	6415	99.477	4.277	93.21	4.582	≤ 5.00
802.11a	6Mbps	97	6435	99.724	4.524	93.21	4.829	≤ 5.00
802.11a	6Mbps	105	6475	99.441	4.241	93.21	4.546	≤ 5.00
802.11a	6Mbps	113	6515	99.836	4.636	93.21	4.941	≤ 5.00
802.11a	6Mbps	117	6535	99.442	4.242	93.21	4.547	≤ 5.00
802.11a	6Mbps	153	6715	99.780	4.580	93.21	4.885	≤ 5.00
802.11a	6Mbps	181	6855	99.508	4.308	93.21	4.613	≤ 5.00
802.11a	6Mbps	185	6875	99.435	4.235	93.21	4.540	≤ 5.00
802.11a	6Mbps	189	6895	99.169	3.969	93.21	4.274	≤ 5.00
802.11a	6Mbps	213	7015	99.358	4.158	93.21	4.463	≤ 5.00
802.11a	6Mbps	229	7095	99.315	4.115	93.21	4.420	≤ 5.00
802.11ax-HE20	MCS0	01	5955	99.001	3.801	93.73	4.082	≤ 5.00
802.11ax-HE20	MCS0	49	6195	98.852	3.652	93.73	3.933	≤ 5.00
802.11ax-HE20	MCS0	93	6415	99.278	4.078	93.73	4.359	≤ 5.00
802.11ax-HE20	MCS0	97	6435	99.175	3.975	93.73	4.256	≤ 5.00
802.11ax-HE20	MCS0	105	6475	99.497	4.297	93.73	4.578	≤ 5.00
802.11ax-HE20	MCS0	113	6515	99.411	4.211	93.73	4.492	≤ 5.00
802.11ax-HE20	MCS0	117	6535	99.451	4.251	93.73	4.532	≤ 5.00
802.11ax-HE20	MCS0	153	6715	99.325	4.125	93.73	4.406	≤ 5.00
802.11ax-HE20	MCS0	181	6855	98.878	3.678	93.73	3.959	≤ 5.00
802.11ax-HE20	MCS0	185	6875	99.038	3.838	93.73	4.119	≤ 5.00
802.11ax-HE20	MCS0	189	6895	98.898	3.698	93.73	3.979	≤ 5.00
802.11ax-HE20	MCS0	213	7015	99.099	3.899	93.73	4.180	≤ 5.00
802.11ax-HE20	MCS0	229	7095	99.085	3.885	93.73	4.166	≤ 5.00

Test Mode	Data Rate/MCS	Channel No.	Freq. (MHz)	EIRP PSD (dBμV/m/MHz)	EIRP PSD (dBm/MHz)	Duty Cycle (%)	Final EIRP PSD (dBm/MHz)	E.I.R.P PSD Limit (dBm/MHz)
802.11ax-HE40	MCS0	03	5965	99.637	4.437	93.98	4.707	≤ 5.00
802.11ax-HE40	MCS0	51	6205	99.110	3.910	93.98	4.180	≤ 5.00
802.11ax-HE40	MCS0	91	6405	99.521	4.321	93.98	4.591	≤ 5.00
802.11ax-HE40	MCS0	99	6445	99.585	4.385	93.98	4.655	≤ 5.00
802.11ax-HE40	MCS0	107	6485	99.619	4.419	93.98	4.689	≤ 5.00
802.11ax-HE40	MCS0	115	6525	99.612	4.412	93.98	4.682	≤ 5.00
802.11ax-HE40	MCS0	123	6565	99.251	4.051	93.98	4.321	≤ 5.00
802.11ax-HE40	MCS0	147	6685	99.604	4.404	93.98	4.674	≤ 5.00
802.11ax-HE40	MCS0	179	6845	99.499	4.299	93.98	4.569	≤ 5.00
802.11ax-HE40	MCS0	187	6885	99.678	4.478	93.98	4.748	≤ 5.00
802.11ax-HE40	MCS0	195	6925	99.493	4.293	93.98	4.563	≤ 5.00
802.11ax-HE40	MCS0	211	7005	99.692	4.492	93.98	4.762	≤ 5.00
802.11ax-HE40	MCS0	227	7085	99.767	4.567	93.98	4.837	≤ 5.00
802.11ax-HE80	MCS0	07	5985	99.819	4.619	93.55	4.909	≤ 5.00
802.11ax-HE80	MCS0	55	6225	99.491	4.291	93.55	4.581	≤ 5.00
802.11ax-HE80	MCS0	87	6385	99.763	4.563	93.55	4.853	≤ 5.00
802.11ax-HE80	MCS0	103	6465	99.892	4.692	93.55	4.982	≤ 5.00
802.11ax-HE80	MCS0	119	6545	99.346	4.146	93.55	4.436	≤ 5.00
802.11ax-HE80	MCS0	135	6625	99.628	4.428	93.55	4.718	≤ 5.00
802.11ax-HE80	MCS0	151	6705	99.532	4.332	93.55	4.622	≤ 5.00
802.11ax-HE80	MCS0	183	6865	99.233	4.033	93.55	4.323	≤ 5.00
802.11ax-HE80	MCS0	199	6945	99.589	4.389	93.55	4.679	≤ 5.00
802.11ax-HE80	MCS0	215	7025	99.363	4.163	93.55	4.453	≤ 5.00
802.11ax-HE160	MCS0	15	6025	99.307	4.107	92.91	4.426	≤ 5.00
802.11ax-HE160	MCS0	47	6185	99.284	4.084	92.91	4.403	≤ 5.00
802.11ax-HE160	MCS0	79	6345	99.524	4.324	92.91	4.643	≤ 5.00
802.11ax-HE160	MCS0	111	6505	99.748	4.548	92.91	4.867	≤ 5.00
802.11ax-HE160	MCS0	143	6665	99.484	4.284	92.91	4.603	≤ 5.00
802.11ax-HE160	MCS0	175	6825	99.442	4.242	92.91	4.561	≤ 5.00
802.11ax-HE160	MCS0	207	6985	99.470	4.270	92.91	4.589	≤ 5.00

Note 1:  $EIRP\ PSD\ (dBm/MHz) = EIRP\ PSD\ (dB\mu V/m/MHz) + Correction\ Factor\ @\ 3m,$  Correction Factor @ 3m =  $20\log(D) - 104.7$ ; where D is the measurement distance @3m = -95.2dB

Note 2: If Duty cycle < 98%, Final EIRP PSD (dBm/MHz) = EIRP PSD (dBm/MHz) +  $10*\log(1/Duty\ cycle)$ .

## 802.11a Power Spectral Density

Channel 01 (5955MHz)

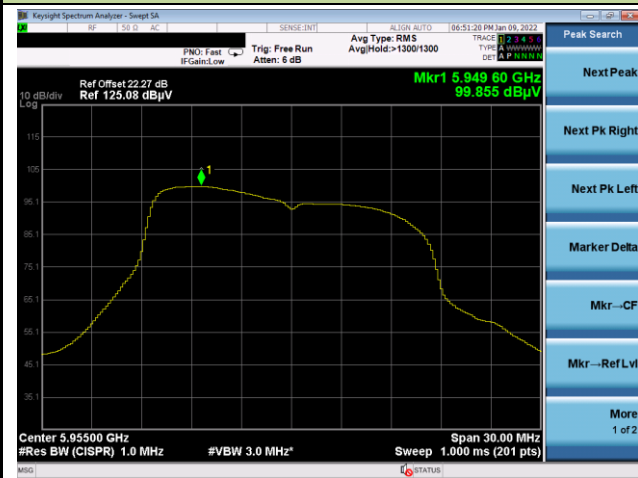

Channel 49 (6195MHz)



Channel 93 (6415MHz)

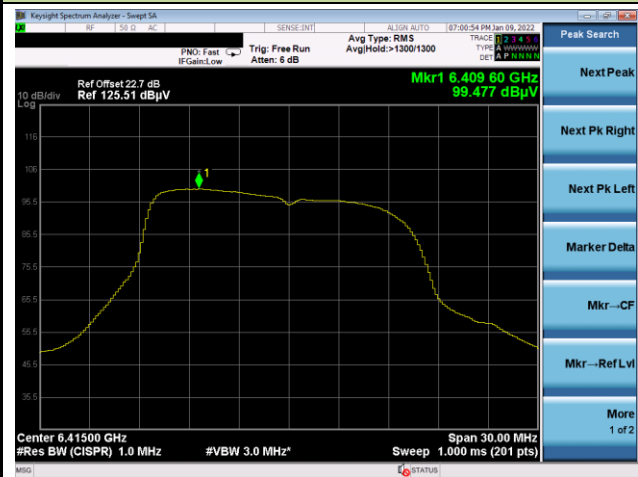

Channel 97 (6435MHz)



Channel 105 (6475MHz)



Channel 113 (6515MHz)

