



Excellence in Compliance Testing

---

## **Certification Exhibit**

**FCC ID: UIDTG1672  
IC: 6670A-TG1672**

**FCC Rule Part: 15.247  
IC Radio Standards Specification: RSS-210**

**ACS Project Number: 12-0355**

**Manufacturer: Arris International, Inc.  
Model: TG1672G & TG1662G**

## **Label Information**



This product is an engineering sample for evaluation in lab testing only. The product should not be provided to end user customers nor should it be used in any revenue generating environment. The product may not have received certification, and/or regulatory (UL/FCC/CE) approval, and is provided AS-IS without any warranties, including, but not limited to, infringement. Otherwise, this product is subject to the standard ARRIS end user license found at [www.arris.com](http://www.arris.com).

**Label Placement**

Figure 1: Label Placement

4

3

2

1

PROPRIETARY NOTICE

THE CONTENTS OF THIS MATERIAL ARE CONFIDENTIAL AND PROPRIETARY TO ARRIS AND SHOULD NOT BE USED, REPRODUCED, PUBLISHED OR DISCLOSED TO OTHERS WITHOUT THE EXPRESS AUTHORIZATION OF ARRIS.

REVISIONS					
ZONE	REV	DESCRIPTION	DATE	REVISED BY	APPROVED BY
	A	RELEASE PER EB-08119	03/21/12	-	CR
	B	RELEASE PER EB-08434	03/07/13	SW	CR
	C	RELEASE PER EB-08515	04/04/13	JFN	CR
	D	RELEASE PER EB-08776	07/17/13	JFN	CR

NOTES:

1. MATERIAL: SEE BOM FOR MATERIAL APPLICATION.
2. ALL LABEL CORNERS: 0.8mm RADIUS.
3. PRE-PRINTED COLORS: BACKGROUND: ARRIS CHARCOAL GRAY; TEXT AND GRAPHICS: WHITE AS NOTED WITH CROSS HATCHING
4. FACTORY PRINTING: BACKGROUND: WHITE; TEXT AND BARCODE: BLACK
5. TYPE: ARIAL REGULAR; TEXT HEIGHT: 6 POINT MINIMUM.
6. ALL LABEL MARKINGS MUST COMPLY WITH ARDO00454 - MARKING REQUIREMENTS FOR ARRIS BROADBAND PRODUCTS.
7. BARCODE SYMBOLOGY TO BE CODE 128 FORMAT AND SHOULD BE A MINIMUM HEIGHT OF 3.7MMM.

ARRIS LOGO TYPE SHOWN IS FOR POSITION ONLY USE ARRIS APPROVED CAMERA READY ART PER QMS0075/7.1

REGULATORY MARKS ARE FOR REFERENCE ONLY USE AGENCY APPROVED CAMERA READY ART

FACTORY PRINTING: BACKGROUND: WHITE TEXT AND BARCODE: BLACK

BACKGROUND COLOR: ARRIS CHARCOAL GRAY TEXT AND GRAPHICS: WHITE

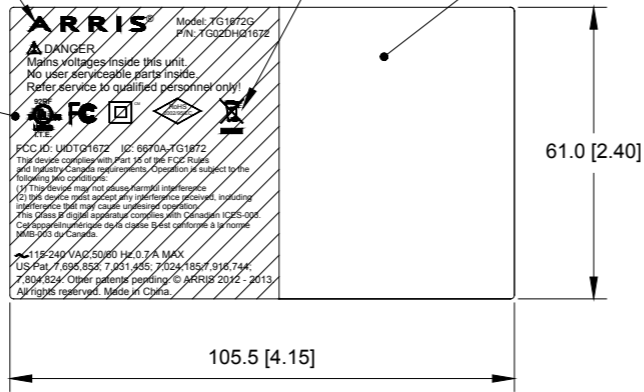

PRE-PRINTED LABEL

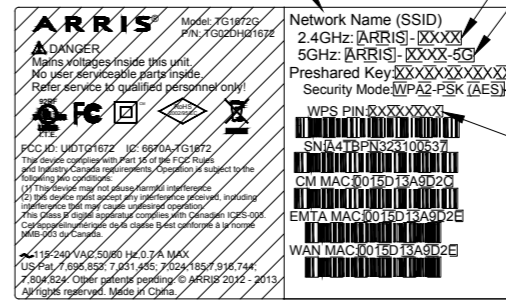

FACTORY PRINTED LABEL

SEE TABLE, COLUMN 1  
SEE TABLE, COLUMN 2  
SEE TABLE, COLUMN 4

SEE TABLE, COLUMN 3

WPS PIN - 8 RANDOM GENERATED NUMBERS

LABEL INFORMATION					
Model	2.4G Field	5G Field	2.4/5G WiFi Radio Decoder	Security Mode Field	Network or Pre-Shared Key Fields
	1	2		3	4
<b>Time Warner</b>	"TG1672GXX"	"TG1672GXX-5G"	"XX" ("XX" = LAST 2 CHARACTERS OF CMAC ADDRESS)	"WPA2-PSK (AES)"	"TG1672GXXXXXX" ("XXXXXX")= last six digits of CMAC address). Use field description "Pre-Shared Key"
<b>ARRIS</b>	"ARRIS-XXXX"	"ARRIS-XXXX-5G"	"XXXX" ("XXXX" = LAST 4 CHARACTERS OF CMAC ADDRESS). Use for 2.4G and 5G field descriptions	"WPA2-PSK (AES)"	"XXXXXXXXXXXXXX" ("XXXXXXXXXXXXXX")= last 12 digits of S/N). Use field description "Pre-Shared Key"

METRIC

• UNLESS OTHERWISE SPECIFIED DIMENSIONS ARE MILLIMETERS TOLERANCES ARE:  
 • DECIMALS ANGLES  
 X ±.1 X ±1°  
 .X ±.1  
 • INTERPRET DRAWINGS PER ANSI Y14.5M - 1994 AND ARRIS QMS0019  
 DO NOT SCALE DRAWING

INFORMATION SUBJECT TO CHANGE WITHOUT NOTICE. ANY HARD COPY OF THIS DOCUMENT IS AN UNCONTROLLED COPY.

APPROVALS  
 DRAWN SW  
 CHECKED  
 APPROVED CR  
 THIRD ANGLE PROJECTION

ARRIS 3871 LAKEFIELD DR, SUITE 300 SUWANEE, GA 30024-1242

TITLE LABEL, REGULATORY, TG1672G

SIZE B DWG NO. ARMP08378DWG REV D

SCALE 1:1 SHEET 1 OF 1

4

3

2

1

DWG NO. ARMP08378DWG SH 1 REV. D

4

3

2

1

PROPRIETARY NOTICE

THE CONTENTS OF THIS MATERIAL ARE CONFIDENTIAL AND PROPRIETARY TO ARRIS AND SHOULD NOT BE USED, REPRODUCED, PUBLISHED OR DISCLOSED TO OTHERS WITHOUT THE EXPRESS AUTHORIZATION OF ARRIS.

REVISIONS

ZONE	REV	DESCRIPTION	DATE	REVISED BY	APPROVED BY
	A	RELEASE PER EB-08434	03/07/13	-	CR
	B	RELEASE PER EB-08515	04/05/13	JFN	CR
	C	RELEASE PER EB-08776	07/17/13	JFN	CR

NOTES:

1. MATERIAL: SEE BOM FOR MATERIAL APPLICATION.
2. ALL LABEL CORNERS: 0.8mm RADIUS.
3. PRE-PRINTED COLORS: BACKGROUND: ARRIS CHARCOAL GRAY; TEXT AND GRAPHICS: WHITE AS NOTED WITH CROSS HATCHING
4. FACTORY PRINTING: BACKGROUND: WHITE; TEXT AND BARCODE: BLACK
5. TYPE: ARIAL REGULAR; TEXT HEIGHT: 6 POINT MINIMUM.
6. ALL LABEL MARKINGS MUST COMPLY WITH ARDO00454 - MARKING REQUIREMENTS FOR ARRIS BROADBAND PRODUCTS.
7. BARCODE SYMBOLOLOGY TO BE CODE 128 FORMAT AND SHOULD BE A MINIMUM HEIGHT OF 3.7MMM.

ARRIS LOGO TYPE SHOWN IS FOR POSITION ONLY USE ARRIS APPROVED CAMERA READY ART PER QMS0075/7.1

REGULATORY MARKS ARE FOR REFERENCE ONLY USE AGENCY APPROVED CAMERA READY ART

BACKGROUND COLOR: WHITE

BACKGROUND COLOR: ARRIS CHARCOAL GRAY TEXT AND GRAPHICS: WHITE

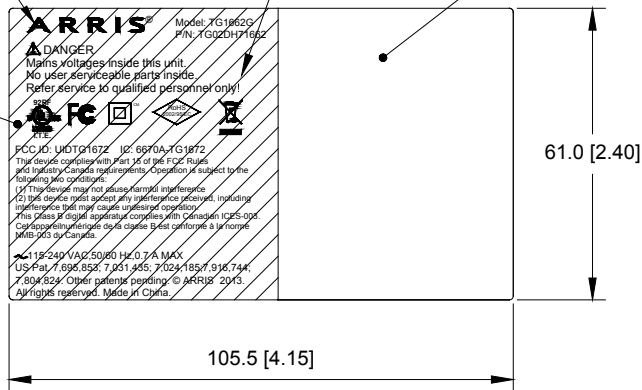

PRE-PRINTED LABEL

FACTORY PRINTING: BACKGROUND: WHITE TEXT AND BARCODE: BLACK

SEE TABLE, COLUMN 1  
SEE TABLE, COLUMN 2  
SEE TABLE, COLUMN 4

SEE TABLE, COLUMN 3

WPS PIN - 8 RANDOM GENERATED NUMBERS

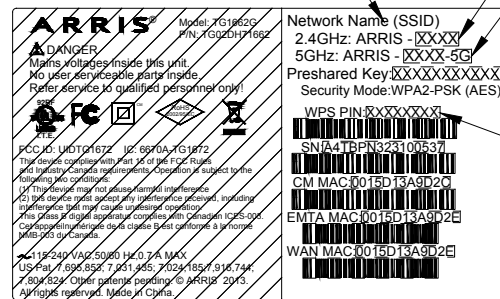

FACTORY PRINTED LABEL

LABEL INFORMATION					
Model	2.4G Field	5G Field	2.4/5G WiFi Radio Decoder	Security Mode Field	Network or Pre-Shared Key Fields
	1	2		3	4
ARRIS	"ARRIS-XXXX"	"ARRIS-XXXX-5G"	"XXXX" ("XXXX" = LAST 4 CHARACTERS OF CMAC ADDRESS). Use for 2.4G and 5G field descriptions	"WPA2-PSK (AES)"	"XXXXXXXXXXXX" ("XXXXXXXXXXXX"= last 12 digits of S/N). Use field description "Pre-Shared Key"

METRIC

UNLESS OTHERWISE SPECIFIED DIMENSIONS ARE MILLIMETERS TOLERANCES ARE:

DECIMALS ANGLES  
X ±.1 X ±1°  
.X ±.1

INTERPRET DRAWINGS PER ANSI Y14.5M - 1994 AND ARRIS QMS0019

DO NOT SCALE DRAWING

INFORMATION SUBJECT TO CHANGE WITHOUT NOTICE. ANY HARD COPY OF THIS DOCUMENT IS AN UNCONTROLLED COPY.

APPROVALS

DRAWN SW

CHECKED

APPROVED CR

THIRD ANGLE PROJECTION

ARRIS 3871 LAKEFIELD DR, SUITE 300 SUWANEE, GA 30024-1242

TITLE LABEL, REGULATORY, TG1662G

SIZE B DWG NO. ARMP08670DWG REV C

SCALE 1:1 SHEET 1 OF 1

4

3

2

1

DWG NO. ARMP08670DWG SH 1 REV. C