

REVISION HISTORY - ALL SHEETS ARE THE SAME REVISION STATUS			
REV	ZONE	DESCRIPTION	ECN MEMO
1	M. TAYLOR	ENGINEERING RELEASE	ECN C453911 3/04/13
2	M. TAYLOR	MODIFIED PRODUCT CODES FOR -005 & -006	ECN C454654 3/28/13
3	M. TAYLOR	RELEASED -008 THRU -012 REMOVED SBG6382 DRAWING VIEWS	ECN C457306 8/12/13
4	M. TAYLOR	ADDED ITEMS 4, 26 & 27 TO DRAWING VIEW	ECN C458094 9/23/13

NOTES: UNLESS OTHERWISE SPECIFIED

1. WORKMANSHIP SHALL BE IN ACCORDANCE WITH THE LATEST REVISION OF ARRIS SPEC 475497-003.
2. FOR NEXT ASSEMBLY AND USED ON APPLICATION, REFER TO LATEST APPROPRIATE ARRIS DATA BASE.
3. SEE TABLE 1 FOR PRODUCT CODE.

△ 4 TORQUE ITEM TO 4-6 IN-LBS.

△ 5 TORQUE ITEM TO 10-12 IN-LBS.

6. THIS DOCUMENT IS THE PROPERTY OF ARRIS GROUP, INC. THIS DOCUMENT MAY ONLY BE DISTRIBUTED TO: (I) AN ARRIS PARTY HAVING A LEGITIMATE BUSINESS NEED FOR THE INFORMATION CONTAINED HEREIN, OR (II) A NON-ARRIS PARTY HAVING A LEGITIMATE BUSINESS NEED FOR THE INFORMATION CONTAINED HEREIN. NO LICENSE, EXPRESSED OR IMPLIED, UNDER ANY PATENT, COPYRIGHT OR TRADE SECRET RIGHT IS GRANTED OR IMPLIED BY THE CONVEYANCE OF THIS DOCUMENT. NO PART OF THIS DOCUMENT MAY BE REPRODUCED, TRANSMITTED, TRANSCRIBED, STORED IN A RETRIEVAL SYSTEM, TRANSLATED INTO ANY LANGUAGE OR COMPUTER LANGUAGE, IN ANY FORM OR BY ANY MEANS, ELECTRONIC, MECHANICAL, MAGNETIC, OPTICAL, CHEMICAL, MANUAL, OR OTHERWISE WITHOUT THE PRIOR WRITTEN PERMISSION OF ARRIS GROUP, INC. (SEE DOCUMENT SECURITY STANDARD, 320190-000 FOR DETAILS.)

THE ARRIS LOGO AND ALL OTHER TRADEMARKS INDICATED AS SUCH HEREIN ARE TRADEMARKS OF ARRIS GROUP, INC. ALL OTHER PRODUCT OR SERVICE NAMES ARE THE PROPERTY OF THEIR RESPECTIVE OWNERS.



COPYRIGHT ARRIS GROUP INC. 2013 ALL RIGHTS RESERVED.

7. CONTROLLED AND REPORTABLE MATERIALS DISCLOSURE (GLOBAL COMPLIANCE)

PRIOR TO PART QUALIFICATION, SUPPLIER MUST PROVIDE ALL REQUIRED INFORMATION TO MEET THE APPROPRIATE ACCEPTANCE CRITERIA OUTLINED IN APPENDIX C OF ARRIS (FORMER HOME) CONTROLLED AND REPORTABLE MATERIALS DISCLOSURE I202897W18-MD-HOME. REPORTING TOOLS CAN BE DOWNLOADED FROM:
<http://responsibility.motorola.com/index.php/suppliers/materialdisclose>

TABLE 1

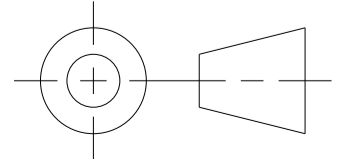
PART NUMBER	PRODUCT CODE	MODEL NAME	MODEL DESCRIPTION	PWA ASSY P/N	PWA PRODUCT CODE
591330-001	3859	SBG6382	N.A. GENERIC	591284-001	3856
591330-004	3864	SBG6482U DIAG		589843-002	3798
591330-005	3865	SBG6482U		589843-003	3894
591330-006	3866	SBG6482	N.A. GENERIC	589843-001	3797
591330-008	3910	SBG6482	W/ARRIS	589843-001	3797
591330-009	3911	SBG6482 DIAG	W/ARRIS	589843-002	3798
591330-010	3912	SBG6482-AC	W/ARRIS	589843-004	3973
591330-011	3913	SBG6482-AC RETAIL	W/ARRIS	589843-004	3973
591330-012	3914	SBG6482-AC DIAG	W/ARRIS	589843-005	3974

COPYRIGHT 2010 ARRIS GROUP, INC. INFORMATION CONTAINED ON ALL SHEETS OF THIS PRINT CANNOT BE REPRODUCED OR USED, IN WHOLE OR IN PART, WITHOUT THE CONSENT OF ARRIS. THIS NOTICE DOES NOT IMPLY PUBLICATION. THIRD ANGLE PROJECTION 	DESIGNED BY T. JUNG			
	DRAWN BY M. TAYLOR			
	APPROVED BY	TITLE SBG6482, CABLE MODEM FINAL ASSEMBLY		
	SIZE A1	CAGE CODE N/A	DRAWING NUMBER 591330	REV 4
	SCALE 1.000	PRODUCT ID SBG6482 SHEET 1 OF 3		

12 11 10 9 8 7 6 5 4 3 2 1

H G F E D C B A

H G F E D C B A

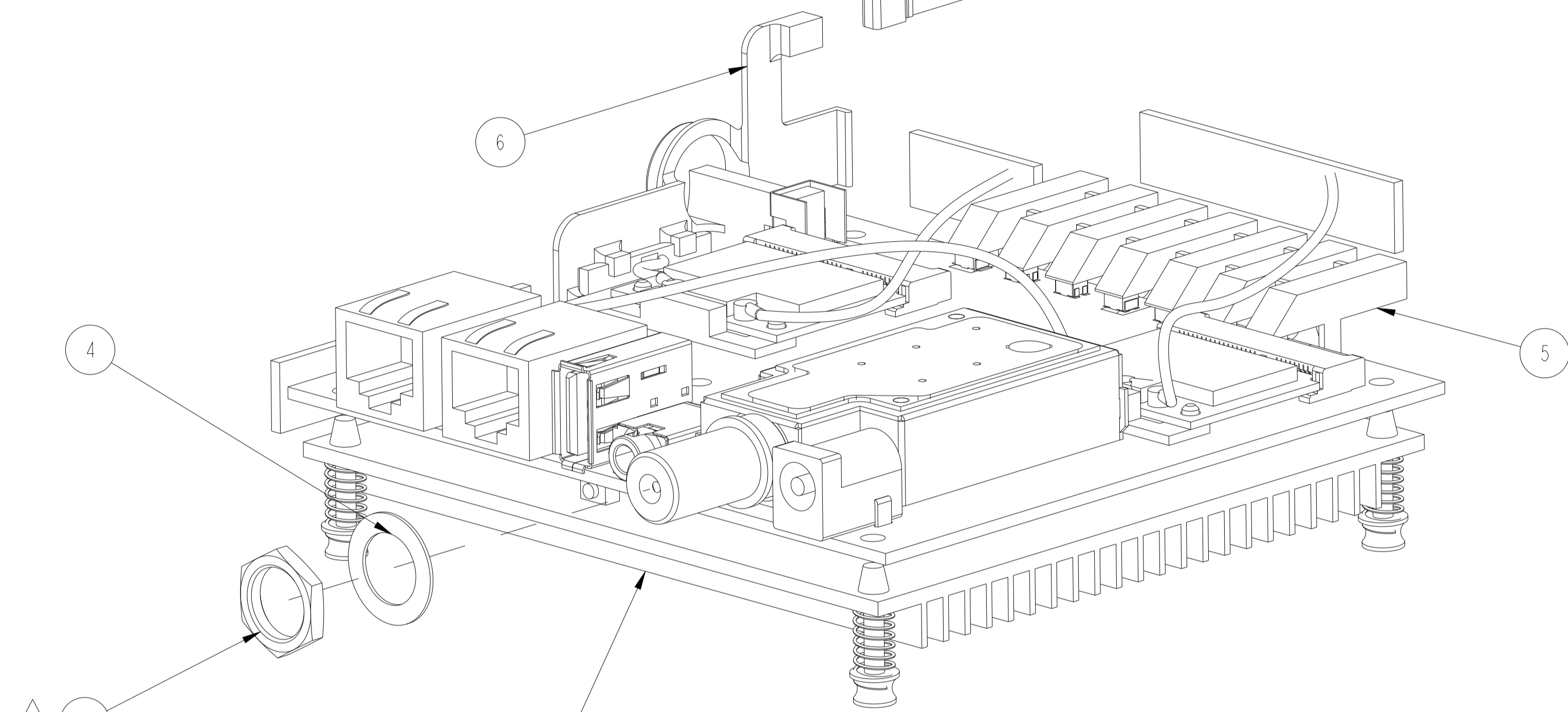
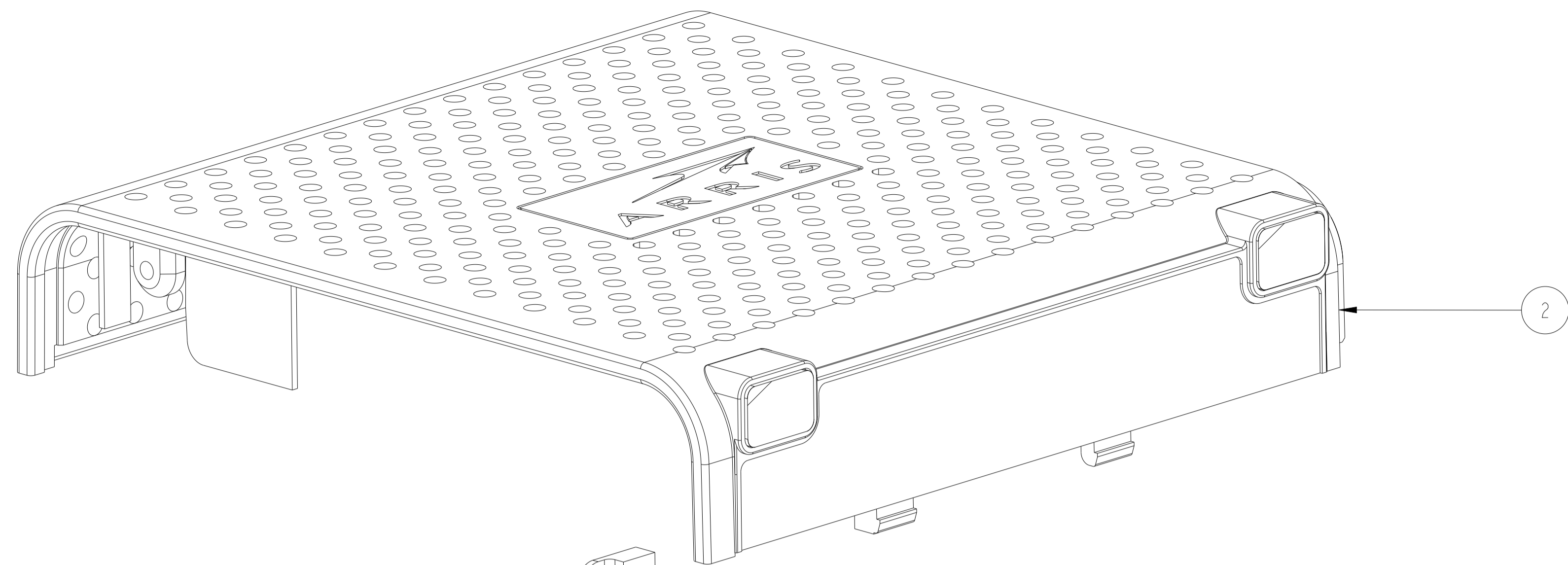

SEE VIEW B

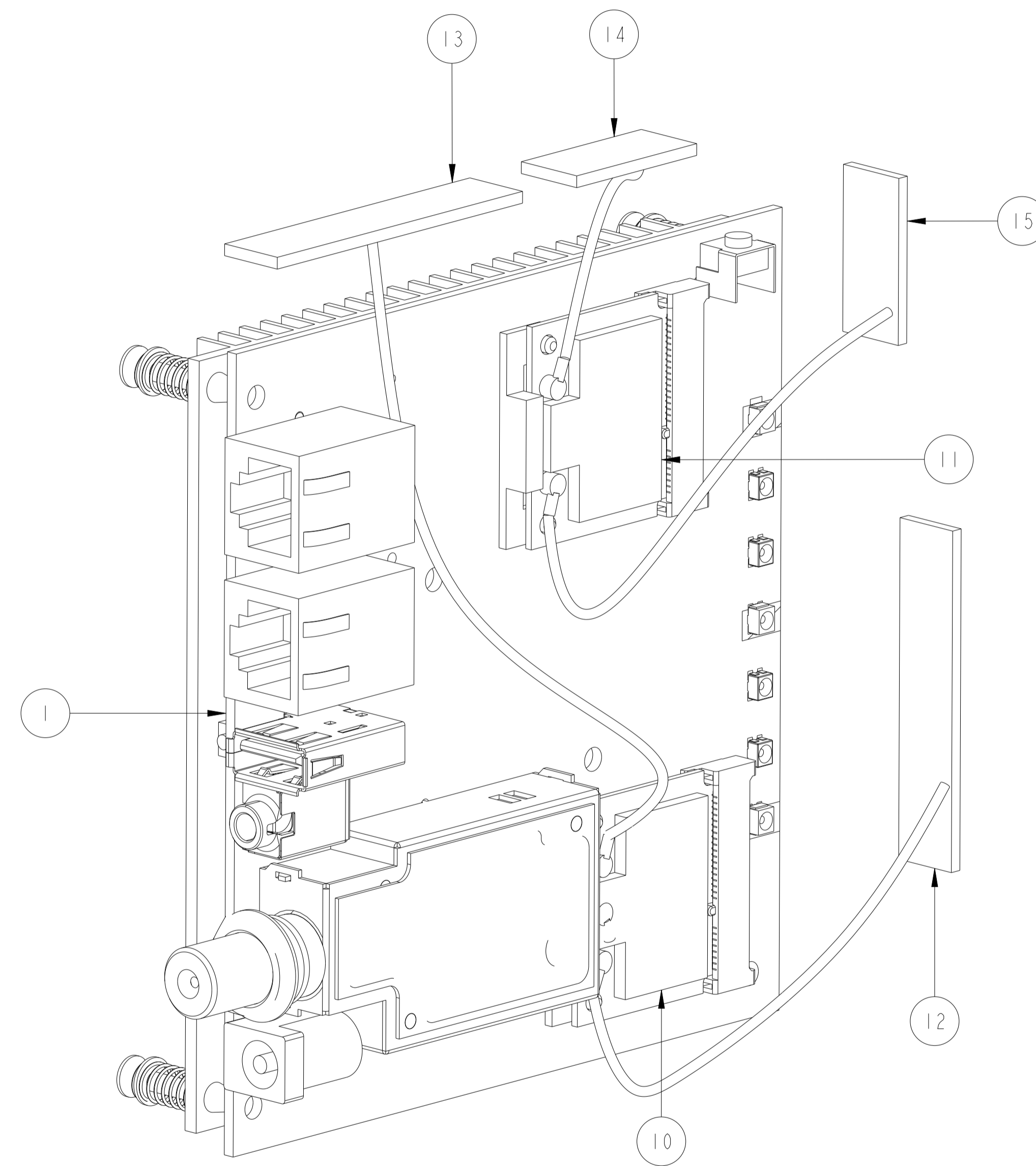
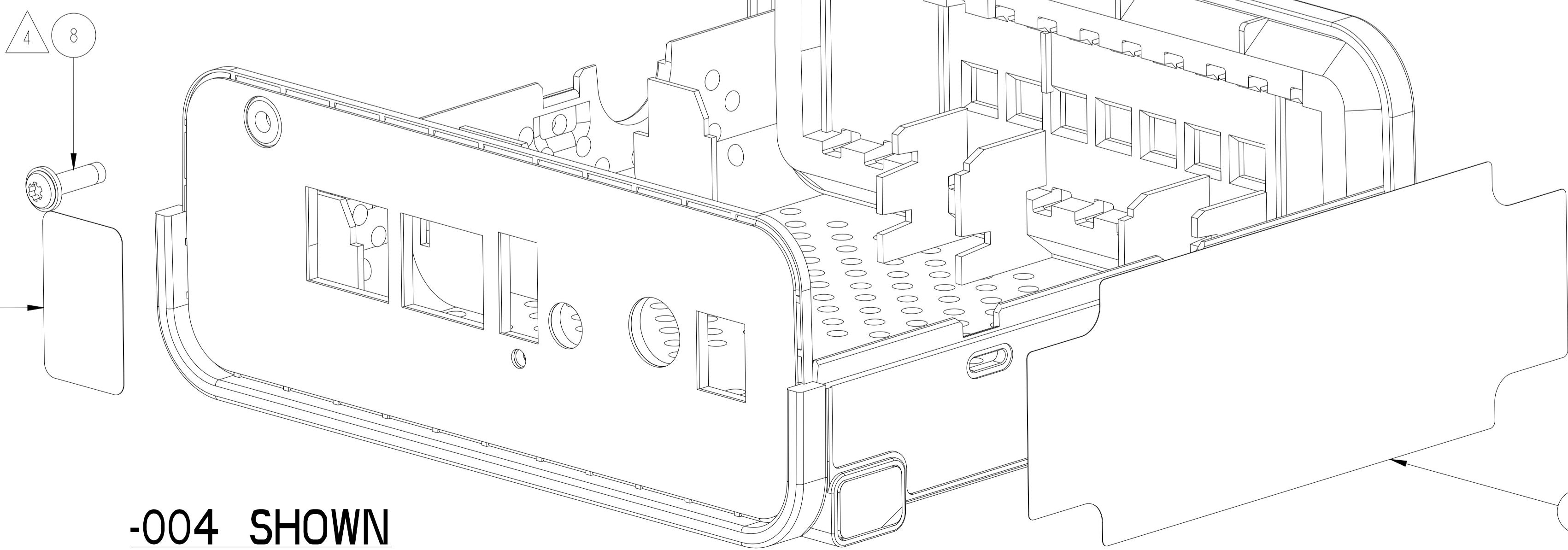

VIEW B

-004 SHOWN

ALL CONFIGURATIONS THE SAME EXCEPT AS INDICATED IN BILL OF MATERIALS
SCALE 2.000

-004 SHOWN

ALL CONFIGURATIONS THE SAME EXCEPT AS INDICATED IN BILL OF MATERIALS
SCALE 2.000

SBG6482-AC VARIANTS NOT REPRESENTED BY THESE VIEWS

REFER TO SHEET 1 OF THIS PRINT FOR PART NUMBER STATUS, REVISION HISTORY, COPYRIGHT NOTICE, AND FULL TITLE BLOCK INFORMATION.	SIZE A1	CAGE CODE N/A	DRAWING NUMBER 591330	REV 4
	SCALE 2.000		PRODUCT ID SBG6482	SHEET 2 OF 3

12 10 9 8 7 6 5 4 3 2 1

12 11 10 9 8 7 6 5 4 3 2 1

H
G
F
E
D
C
B
A

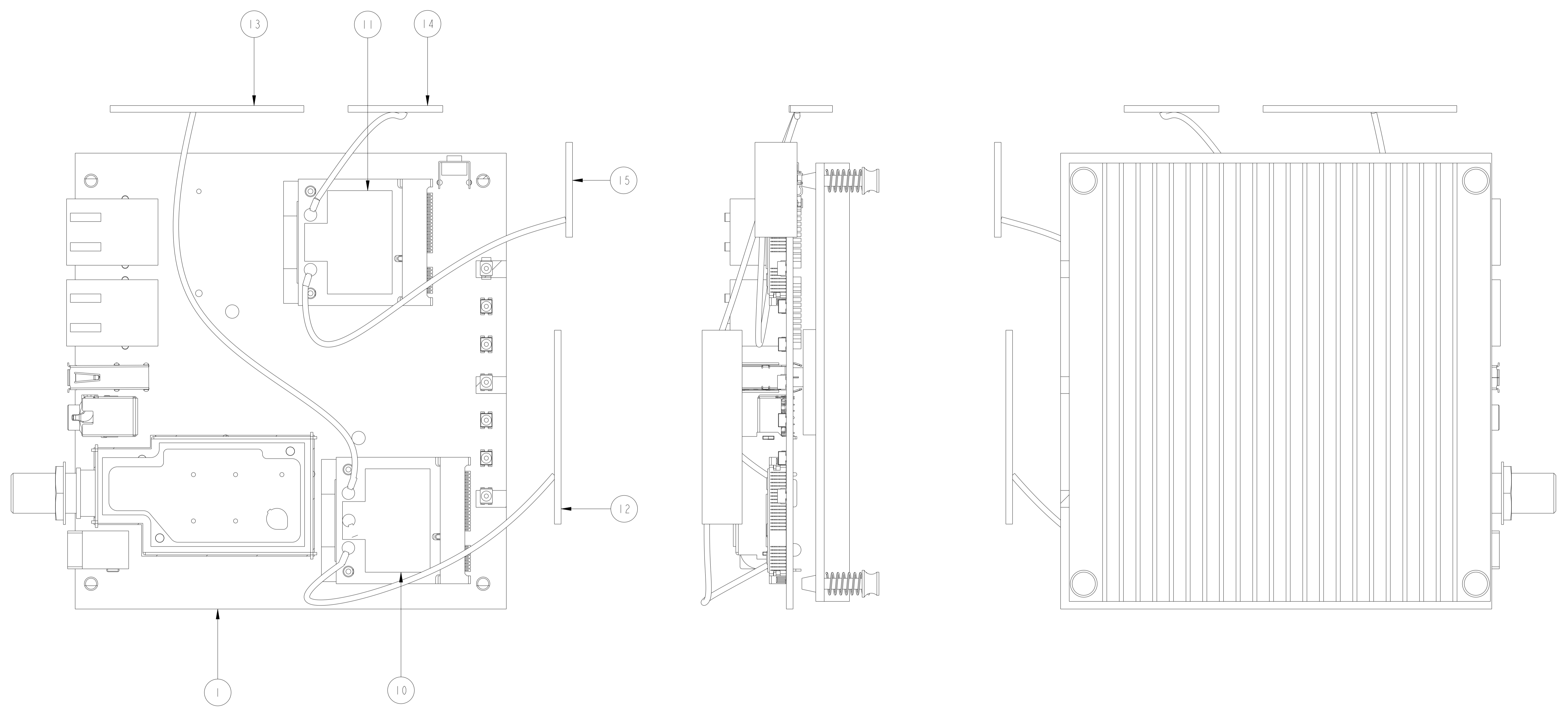

WI-FI RADIO AND ANTENNA ASSEMBLY

-004 SHOWN
 ALL CONFIGURATIONS THE SAME EXCEPT AS
 INDICATED IN BILL OF MATERIALS
 SCALE 2.000

SBG6482-AC VARIANTS NOT REPRESENTED BY THESE VIEWS

REFER TO SHEET 1 OF THIS PRINT FOR PART NUMBER STATUS, REVISION HISTORY, COPYRIGHT NOTICE, AND FULL TITLE BLOCK INFORMATION.	SIZE A1	CAGE CODE N/A	DRAWING NUMBER 591330	REV 4
	SCALE 2.000	PRODUCT ID SBG6482 SHEET 3 OF 3		

12 10 9 8 7 6 5 4 3 2 1

COMPUTER GENERATED PRINT
DO NOT SCALE
DO NOT REVISE MANUALLY