



MET Laboratories, Inc. *Safety Certification - EMI - Telecom Environmental Simulation*

914 WEST PATAPSCO AVENUE • BALTIMORE, MARYLAND 21230-3432 • PHONE (410) 354-3300 • FAX (410) 354-3313
33439 WESTERN AVENUE • UNION CITY, CALIFORNIA 94587 • PHONE (510) 489-6300 • FAX (510) 489-6372
3162 BELICK STREET • SANTA CLARA, CALIFORNIA 95054 • PHONE (408) 748-3585 • FAX (510) 489-6372
13501 MCCALLEN PASS • AUSTIN, TX 78753 • PHONE (512) 287-2500 • FAX (512) 287-2513

December 9, 2016

ARRIS Group, Inc.
3871 Lakefield Drive Suite 300
Suwanee, GA 30024

Dear Tony Figueiredo,

Enclosed is the EMC Wireless test report for compliance testing of the ARRIS Group, Inc., OG1600 as tested to the requirements of Title 47 of the CFR, Ch. 1 (10-1-06 ed.), Title 47 of the CFR, Part 15.407, Subpart E (UNII 3).

Thank you for using the services of MET Laboratories, Inc. If you have any questions regarding these results or if MET can be of further service to you, please feel free to contact me.

Sincerely yours,
MET LABORATORIES, INC.

Jennifer Warnell
Documentation Department

Reference: (\ARRIS Group, Inc.\EMC88858-FCC407 UNII 3 Rev. 3)

Certificates and reports shall not be reproduced except in full, without the written permission of MET Laboratories, Inc.



MET Laboratories, Inc. *Safety Certification - EMI - Telecom Environmental Simulation*

914 WEST PATAPSCO AVENUE • BALTIMORE, MARYLAND 21230-3432 • PHONE (410) 354-3300 • FAX (410) 354-3313

33439 WESTERN AVENUE • UNION CITY, CALIFORNIA 94587 • PHONE (510) 489-6300 • FAX (510) 489-6372

3162 BELICK STREET • SANTA CLARA, CALIFORNIA 95054 • PHONE (408) 748-3585 • FAX (510) 489-6372

13501 MCCALLEN PASS • AUSTIN, TX 78753 • PHONE (512) 287-2500 • FAX (512) 287-2513

**Electromagnetic Compatibility Criteria
Test Report**

for the

**ARRIS Group, Inc.
Model OG1600**

Tested under
The FCC Certification Rules
contained in
Title 47 of the CFR
15.407 Subpart E

MET Report: EMC88858-FCC407 UNII 3 Rev. 3

December 9, 2016

Prepared For:

**ARRIS Group, Inc.
3871 Lakefield Drive Suite 300
Suwanee, GA 30024**

Prepared By:
MET Laboratories, Inc.
914 W. Patapsco Ave.
Baltimore, MD 21230

Electromagnetic Compatibility Criteria Test Report

for the

ARRIS Group, Inc.
Model OG1600

Tested under
The FCC Certification Rules
contained in
Title 47 of the CFR
15.407 Subpart E



Hadid Jones, Project Engineer
Electromagnetic Compatibility Lab

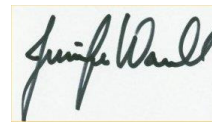

Jennifer Warnell
Documentation Department

Engineering Statement: The measurements shown in this report were made in accordance with the procedures indicated, and the emissions from this equipment were found to be within the limits applicable. I assume full responsibility for the accuracy and completeness of these measurements, and for the qualifications of all persons taking them. It is further stated that upon the basis of the measurements made, the equipment tested is capable of operation in accordance with the requirements of Parts 15B, 15.407, of the FCC Rules under normal use and maintenance.



Asad Bajwa,
Director, Electromagnetic Compatibility Lab

Report Status Sheet

Revision	Report Date	Reason for Revision
∅	September 14, 2016	Initial Issue.
1	October 21, 2016	Retest.
2	November 16, 2016	Editorial corrections.
3	December 9, 2016	Added antenna gain calculations.

Table of Contents

I.	Executive Summary	1
	A. Purpose of Test	2
	B. Executive Summary	2
II.	Equipment Configuration	3
	A. Overview.....	4
	B. References.....	4
	C. Test Site	5
	D. Description of Test Sample.....	5
	E. Equipment Configuration.....	5
	F. Support Equipment	6
	G. Ports and Cabling Information.....	6
	H. Mode of Operation.....	6
	I. Method of Monitoring EUT Operation	6
	J. Modifications	6
	a) Modifications to EUT	6
	b) Modifications to Test Standard	6
	K. Disposition of EUT	6
III.	Electromagnetic Compatibility Criteria for Intentional Radiators.....	7
	§ 15.203 Antenna Requirement.....	8
	§ 15.403(i) 26 dB Bandwidth	11
	§ 15.407(a)(3) Maximum Conducted Output Power	13
	§ 15.407(a)(3) Maximum Power Spectral Density	15
	§ 15.407(b)(4) & (6 - 7) Undesirable Emissions	17
	§ 15.407(b)(6) Conducted Emissions	33
	§ 15.407(e) 6 dB Bandwidth.....	36
	§ 15.247(i) Maximum Permissible Exposure	37
IV.	Test Equipment	38
V.	Certification & User's Manual Information.....	40
	A. Certification Information	41
	B. Label and User's Manual Information	45

List of Tables

Table 1.	Executive Summary of EMC Part 15.407 Compliance Testing	2
Table 2.	EUT Summary.....	4
Table 3.	References	4
Table 4.	Equipment Configuration	5
Table 5.	Support Equipment.....	6
Table 6.	Ports and Cabling Information	6
Table 7.	26 dB Occupied Bandwidth, Test Results	12
Table 8.	Conducted Output Power, Test Results	14
Table 9.	Power Spectral Density, Test Results.....	16
Table 10.	Conducted Limits for Intentional Radiators from FCC Part 15 § 15.207(a)	33
Table 11.	Conducted Emissions, 15.207(a), Phase Line, Test Results	34
Table 12.	Conducted Emissions, 15.207(a), Neutral Line, Test Results	35
Table 13.	6 dB Occupied Bandwidth, Test Results	36
Table 14.	Test Equipment List	39

List of Figures

Figure 1. Block Diagram of Test Configuration.....	5
--	---

List of Plots

Plot 1. Radiated Spurious Emissions, 30 MHz – 1 GHz, Radio Off	18
Plot 2. Radiated Spurious Emissions, 30 MHz – 1 GHz, Radio On	18
Plot 3. Radiated Spurious Emissions, 802.11a 20 MHz, Low Channel, 1 GHz – 18 GHz.....	19
Plot 4. Radiated Spurious Emissions, 802.11a 20 MHz, High Channel, 1 GHz – 18 GHz.....	19
Plot 5. Radiated Spurious Emissions, 802.11ac 20 MHz, Low Channel, 1 GHz – 18 GHz.....	20
Plot 6. Radiated Spurious Emissions, 802.11ac 20 MHz, Low Channel, 1 GHz – 18 GHz.....	20
Plot 9. Radiated Spurious Emissions, 802.11ac 40 MHz, Low Channel, 1 GHz – 18 GHz.....	21
Plot 10. Radiated Spurious Emissions, 802.11ac 40 MHz, High Channel, 1 GHz – 18 GHz	21
Plot 11. Radiated Spurious Emissions, 802.11ac 80 MHz, 1 GHz – 18 GHz	22
Plot 12. Radiated Spurious Emissions, 802.11n 20 MHz, Low Channel, 1 GHz – 18 GHz	23
Plot 13. Radiated Spurious Emissions, 802.11n 20 MHz, High Channel, 1 GHz – 18 GHz.....	23
Plot 14. Radiated Spurious Emissions, 802.11n 40 MHz, Low Channel, 1 GHz – 18 GHz	24
Plot 15. Radiated Spurious Emissions, 802.11n 40 MHz, High Channel, 1 GHz – 18 GHz.....	24
Plot 16. Radiated Band Edge, 802.11a 20 MHz, Low Channel	25
Plot 17. Radiated Band Edge, 802.11a 20 MHz, High Channel.....	25
Plot 18. Radiated Band Edge, 802.11ac 20 MHz, Low Channel.....	26
Plot 19. Radiated Band Edge, 802.11ac 20 MHz, Low Channel.....	26
Plot 20. Radiated Band Edge, 802.11ac 20 MHz, High Channel	27
Plot 21. Radiated Band Edge, 802.11ac 20 MHz, High Channel	27
Plot 22. Radiated Band Edge, 802.11ac 40 MHz, Low Channel.....	28
Plot 23. Radiated Band Edge, 802.11ac 40 MHz, High Channel	28
Plot 24. Radiated Band Edge, 802.11ac 80 MHz	29
Plot 25. Radiated Band Edge, 802.11n 20 MHz, Low Channel	30
Plot 26. Radiated Band Edge, 802.11n 20 MHz, High Channel.....	30
Plot 27. Radiated Band Edge, 802.11n 40 MHz, Low Channel	31
Plot 28. Radiated Band Edge, 802.11n 40 MHz, High Channel.....	31
Plot 29. Conducted Emissions, 15.207(a), Phase Line	34
Plot 30. Conducted Emissions, 15.207(a), Neutral Line	35

List of Terms and Abbreviations

AC	Alternating Current
ACF	Antenna Correction Factor
Cal	Calibration
<i>d</i>	Measurement Distance
dB	Decibels
dB μ A	Decibels above one microamp
dB μ V	Decibels above one microvolt
dB μ A/m	Decibels above one microamp per meter
dB μ V/m	Decibels above one microvolt per meter
DC	Direct Current
E	Electric Field
DSL	Digital Subscriber Line
ESD	Electrostatic Discharge
EUT	Equipment Under Test
<i>f</i>	Frequency
FCC	Federal Communications Commission
GRP	Ground Reference Plane
H	Magnetic Field
HCP	Horizontal Coupling Plane
Hz	Hertz
IEC	International Electrotechnical Commission
kHz	Kilohertz
kPa	Kilopascal
kV	Kilovolt
LISN	Line Impedance Stabilization Network
MHz	Megahertz
μ H	Microhenry
μ	Microfarad
μ s	Microseconds
PRF	Pulse Repetition Frequency
RF	Radio Frequency
RMS	Root-Mean-Square
TWT	Traveling Wave Tube
V/m	Volts per meter
VCP	Vertical Coupling Plane

I. Executive Summary

A. Purpose of Test

An EMC evaluation was performed to determine compliance of the ARRIS Group, Inc. OG1600, with the requirements of Part 15, §15.407. All references are to the most current version of Title 47 of the Code of Federal Regulations in effect. In accordance with §2.1033, the following data is presented in support of the Certification of the OG1600. ARRIS Group, Inc. should retain a copy of this document which should be kept on file for at least two years after the manufacturing of the OG1600, has been **permanently** discontinued.

B. Executive Summary

The following tests were conducted on a sample of the equipment for the purpose of demonstrating compliance with Part 15, §15.407, in accordance with ARRIS Group, Inc., purchase order number AR1077686. All tests were conducted using measurement procedure ANSI C63.4-2014.

FCC Reference	Description	Results
§15.203	Antenna Requirement	Compliant
§15.403(i)	26 dB Bandwidth	Compliant
§15.407 (a)(3)	Maximum Conducted Output Power	Compliant
§15.407 (a)(3)	Maximum Power Spectral Density	Compliant
§15.407 (b)(4)& (6 - 7)	Undesirable Emissions	Compliant
§15.407(b)(6)	Conducted Emission Limits	Compliant
§15.407(e)	6 dB Bandwidth	Compliant
§15.407(f)	RF Exposure	Compliant

Table 1. Executive Summary of EMC Part 15.407 Compliance Testing

II. Equipment Configuration

A. Overview

MET Laboratories, Inc. was contracted by ARRIS Group, Inc. to perform testing on the OG1600, under ARRIS Group, Inc.'s purchase order number AR1077686.

This document describes the test setups, test methods, required test equipment, and the test limit criteria used to perform compliance testing of the ARRIS Group, Inc. OG1600.

The results obtained relate only to the item(s) tested.

Model(s) Tested:	OG1600	
Model(s) Covered:	OG1600	
EUT Specifications:	Primary Power: 45-90 VAC	
	FCC ID: UIDOG1600CT	
	Type of Modulations:	CCK, OFDM
	Equipment Code:	NII
	Max. RF Output Power:	29.53 dBm
	EUT Frequency Ranges:	5745-5825 MHz
Analysis:	The results obtained relate only to the item(s) tested.	
Environmental Test Conditions:	Temperature: 15-35° C	
	Relative Humidity: 30-60%	
	Barometric Pressure: 860-1060 mbar	
Evaluated by:	Hadid Jones	
Report Date(s):	December 9, 2016	

Table 2. EUT Summary

B. References

CFR 47, Part 15, Subpart E	Unlicensed National Information Infrastructure Devices (UNII)
ANSI C63.4:2014	Methods and Measurements of Radio-Noise Emissions from Low-Voltage Electrical And Electronic Equipment in the Range of 9 kHz to 40 GHz
ISO/IEC 17025:2005	General Requirements for the Competence of Testing and Calibration Laboratories
ANSI C63.10-2013	American National Standard for Testing Unlicensed Wireless Devices

Table 3. References

C. Test Site

All testing was performed at MET Laboratories, Inc., 914 W. Patapsco Ave., Baltimore, MD 21230. All equipment used in making physical determinations is accurate and bears recent traceability to the National Institute of Standards and Technology.

Radiated Emissions measurements were performed in a 3 meter semi-anechoic chamber (equivalent to an Open Area Test Site). In accordance with §2.948(a)(3), a complete site description is contained at MET Laboratories.

D. Description of Test Sample

The ARRIS Group, Inc. OG1600, Equipment Under Test (EUT), is an outdoor 2.4 GHz & 5 GHz data gateway.

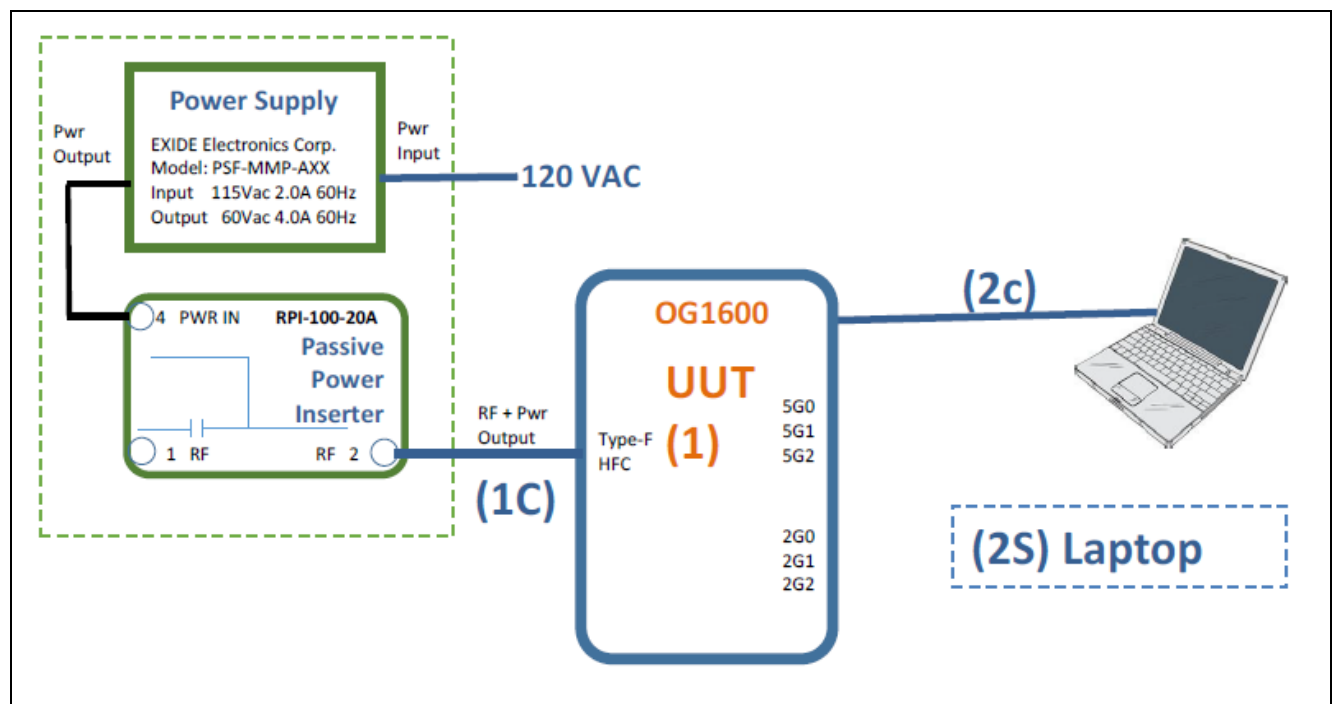

Figure 1. Block Diagram of Test Configuration

Equipment Configuration

The EUT was set up as outlined in Figure 1, Block Diagram of Test Setup. All cards, racks, etc., incorporated as part of the EUT is included in the following list.

Ref. ID	Name / Description	Model Number	Part Number	Serial Number	Revision
--	OG1600 Outdoor Access Point	--	--	--	--

Table 4. Equipment Configuration

E. Support Equipment

Support equipment necessary for the operation and testing of the EUT is included in the following list.

Ref. ID	Name / Description	Manufacturer	Model Number
2s	Laptop	Assorted	N/A

Table 5. Support Equipment

F. Ports and Cabling Information

Ref. ID	Port Name on EUT	Cable Description	Qty.	Length (m)	Shielded (Y/N)	Termination Point
2C	Ethernet	5e Modular 8 pin	1	1	No	--
1C	Coax	AC, quasi-square wave	1	2	--	--

Table 6. Ports and Cabling Information

G. Mode of Operation

The provided instructions and software will configure the OG1600 for operation at each required test mode. See configuration.

H. Method of Monitoring EUT Operation

The measured emission value is over the specified FCC/IC limits.

I. Modifications

a) Modifications to EUT

No modifications were made to the EUT.

b) Modifications to Test Standard

No modifications were made to the test standard.

J. Disposition of EUT

The test sample including all support equipment submitted to the Electro-Magnetic Compatibility Lab for testing was returned to ARRIS Group, Inc. upon completion of testing.

III. Electromagnetic Compatibility Criteria for Intentional Radiators

Electromagnetic Compatibility Criteria for Intentional Radiators

§ 15.203 Antenna Requirement

Test Requirement: § 15.203: An intentional radiator shall be designed to ensure that no antenna other than that furnished by the responsible party shall be used with the device. The use of a permanently attached antenna or of an antenna that uses a unique coupling to the intentional radiator shall be considered sufficient to comply with the provisions of this section. The manufacturer may design the unit so that a broken antenna can be replaced by the user, but the use of a standard antenna jack or electrical connector is prohibited.

The structure and application of the EUT were analyzed to determine compliance with Section 15.203 of the Rules. Section 15.203 states that the subject device must meet at least one of the following criteria:

- a.) Antenna must be permanently attached to the unit.
- b.) Antenna must use a unique type of connector to attach to the EUT.
- b.) Unit must be professionally installed. Installer shall be responsible for verifying that the correct antenna is employed with the unit.

Note: conducted testing was performed using a modified sample where the antenna was replaced with a coaxial cable.

Results: The EUT as tested is compliant the criteria of §15.203. The EUT has an integral antenna.

Test Engineer(s): Hadid Jones

Test Date(s): 10/12/16

Gain-pk : All Space

Unequal Antenna Gains, with equal transmit powers

1) if transmit signals are **Correlated**

KDB 662911 D01 2) d) i), e) ii) (each transmit antenna is driven only by one spatial stream)

		G1	G2	G3	Direction Gain
Band	Tx Chains	dBi	dBi	dBi	dBi
	3	3.7	3.8	4.1	8.64
UNII-1	3	5.1	5.2	5.7	10.11
UNII-2A	3	5	5.1	5.6	10.01
UNII-2C	3	5.4	5.5	6	10.41
UNII-3	3	5.1	5.2	5.7	10.11

2) if transmit signals are **UnCorrelated**

KDB 662911 D01 2) d) ii)

		G1	G2	G3	Direction Gain
Band	Tx Chains	dBi	dBi	dBi	dBi
	3	3.7	3.8	4.1	3.87
UNII-1	3	5.1	5.2	5.7	5.34
UNII-2A	3	5	5.1	5.6	5.24
UNII-2C	3	5.4	5.5	6	5.64
UNII-3	3	5.1	5.2	5.7	5.34

Gain-pk Skyward¹, Only

Unequal Antenna Gains, with equal transmit powers

1) if transmit signals are **Correlated**

KDB 662911 D01 2) d) i), e) ii) (each transmit antenna is driven only by one spatial stream)

		G1	G2	G3	Direction Gain
Band	Tx Chains	dBi	dBi	dBi	dBi
UNII-1	3	-7.5	-7.4	-6.9	-2.49

2) if transmit signals are **Uncorrelated**

KDB 662911 D01 2) d) ii)

		G1	G2	G3	Direction Gain
Band	Tx Chains	dBi	dBi	dBi	dBi
UNII-1	3	-7.5	-7.4	-6.9	-7.26

Note(s)

1) Skyward Gain: 15.407(a)(1)(i) : The maximum EIRP +21dBm at any elevation angle above 30 degrees as measured from the horizon.

Electromagnetic Compatibility Criteria for Intentional Radiators

§ 15. 403(i) 26 dB Bandwidth

Test Requirements: § 15.403(i): For purposes of this subpart the emission bandwidth shall be determined by measuring the width of the signal between two points, one below the carrier center frequency and one above the carrier center frequency, that are 26 dB down relative to the maximum level of the modulated carrier. Determination of the emissions bandwidth is based on the use of measurement instrumentation employing a peak detector function with an instrument resolution bandwidth approximately equal to 1.0 percent of the emission bandwidth of the device under measurement.

Test Procedure: The transmitter was set to low, mid, and high operating frequencies at the highest output power and connected to the spectrum analyzer through an attenuator. The bandwidth of the fundamental frequency was measured with the spectrum analyzer using a RBW approximately equal to 1% of the total emission bandwidth, VBW > RBW. The 26 dB Bandwidth was measured and recorded.

Test Results The 26 dB Bandwidth was compliant with the requirements of this section.

Test Engineer(s): Hadid Jones

Test Date(s): 10/14/16

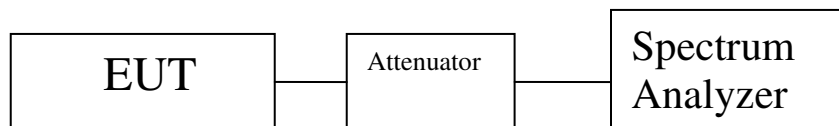

Mode	OBW	26dB
BW 20M_Ch 5745M_a mode r6 TP18.5	16.4319	16.4
BW 20M_Ch 5805M_a mode r6 TP18.5	16.4583	16.4
BW 20M_Ch 5825M_a mode r6 TP18.5	16.436	16.4
BW 20M_Ch 5745M_ac mode vt0 TP18.5	17.6322	17.5
BW 20M_Ch 5805M_ac mode vt0 TP18.5	17.6164	17.6
BW 20M_Ch 5825M_ac mode vt0 TP18.5	17.5905	17.5
BW 40M_Ch 5755M_ac mode vf0 TP19.5	36.0577	35.7
BW 40M_Ch 5795M_ac mode vf0 TP19.5	36.041	35.8
BW 80M_Ch 5775M_ac mode ve0 TP20.5	75.3833	73.2
BW 20M_Ch 5745M_n mode t0 TP18.5	17.6249	17.6
BW 20M_Ch 5805M_n mode t0 TP18.5	17.6035	17.3
BW 20M_Ch 5825M_n mode t0 TP18.5	17.6238	17.5
BW 40M_Ch 5755M_n mode f0 TP19.5	36.1016	35.9
BW 40M_Ch 5795M_n mode f0 TP19.5	36.1215	36.3

Table 7. 26 dB Occupied Bandwidth, Test Results

Electromagnetic Compatibility Criteria for Intentional Radiators

§15.407(a)(3) Maximum Conducted Output Power

Test Requirements: §15.407(a)(3): For the band 5.725-5.85 GHz, the maximum conducted output power over the frequency band of operation shall not exceed 1 W.

If transmitting antennas of directional gain greater than 6 dBi are used, both the maximum conducted output power and the maximum power spectral density shall be reduced by the amount in dB that the directional gain of the antenna exceeds 6 dBi. However, fixed point-to-point U-NII devices operating in this band may employ transmitting antennas with directional gain greater than 6 dBi without any corresponding reduction in transmitter conducted power.

Test Procedure: The EUT was connected to a spectrum analyzer through a cable and attenuator. Measurements were taken with the EUT set to transmit continuously on its low, mid, and high channels. Its power was measured according to measurement method SA-1, as described in 789033 D02 General UNII Test Procedures v01.

The antenna gain was calculated based on whether the data was correlated or not per KDB 662911. For b and g mode the data is correlated and thus the gain is the array gain of all three antennas. For n mode the data is completely uncorrelated and thus the gain is the single antenna gain.

Test Results: The EUT as tested is compliant with the requirements of this section.

Test Engineer(s): Hadid Jones

Test Date(s): 10/14/16

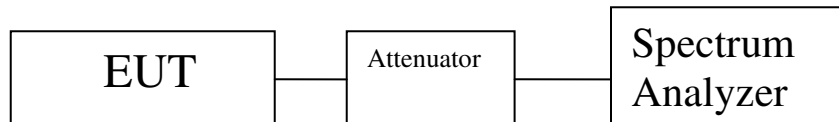

Frequency (MHz)	BW	802.11 mode	Diversity Scheme	NSS	Port 1 PWR (dBm)	Port 2 PWR (dBm)	Port 3 PWR (dBm)	S PWR P1,P2,P3 (dBm)	Limit (dBm)	Gain-pk (dBi)	Final Limit (dBm)	Margin (dB)
5745	20	a	CDD	NSS1	19.81	20.07	20.46	24.89	30	10.11	25.89	-1.00
5745	20	ac	CDD	NSS1	19.88	20.33	20.35	24.96	30	10.11	25.89	-0.93
5745	20	ac	SDM	NSS3	24.34	24.92	24.88	29.49	30	5.34	30.00	-0.51
5745	20	n	CDD	NSS1	19.88	20.24	20.37	24.94	30	10.11	25.89	-0.95
5745	20	n	SDM	NSS3	24.46	24.80	24.92	29.50	30	5.34	30.00	-0.50
5805	20	a	CDD	NSS1	19.69	19.78	20.60	24.81	30	10.11	25.89	-1.08
5805	20	ac	CDD	NSS1	19.63	20.02	20.56	24.86	30	10.11	25.89	-1.03
5805	20	ac	SDM	NSS3	23.90	24.16	24.51	28.97	30	5.34	30.00	-1.03
5805	20	n	CDD	NSS1	19.59	19.88	20.52	24.79	30	10.11	25.89	-1.10
5805	20	n	SDM	NSS3	23.92	24.13	24.45	28.94	30	5.34	30.00	-1.06
5825	20	a	CDD	NSS1	19.80	19.88	20.63	24.89	30	10.11	25.89	-1.00
5825	20	ac	CDD	NSS1	19.72	20.22	20.50	24.93	30	10.11	25.89	-0.96
5825	20	ac	SDM	NSS3	23.80	24.38	22.59	28.42	30	5.34	30.00	-1.58
5825	20	n	CDD	NSS1	19.76	20.08	20.44	24.87	30	10.11	25.89	-1.02
5825	20	n	SDM	NSS3	23.70	24.40	24.55	29.00	30	5.34	30.00	-1.00
5755	40	ac	CDD	NSS1	19.91	20.32	20.45	25.00	30	10.11	25.89	-0.89
5755	40	ac	SDM	NSS3	24.53	24.84	24.91	29.53	30	5.34	30.00	-0.47
5755	40	n	CDD	NSS1	20.05	20.37	20.43	25.06	30	10.11	25.89	-0.83
5755	40	n	SDM	NSS3	24.56	24.79	24.83	29.50	30	5.34	30.00	-0.50
5795	40	ac	CDD	NSS1	19.98	20.28	20.55	25.05	30	10.11	25.89	-0.84
5795	40	ac	SDM	NSS3	24.29	24.45	24.48	29.18	30	5.34	30.00	-0.82
5795	40	n	CDD	NSS1	20.05	20.40	20.45	25.07	30	10.11	25.89	-0.82
5795	40	n	SDM	NSS3	24.24	24.42	24.6	29.19	30	5.34	30.00	-0.81
5775	80	ac	CDD	NSS1	20.27	20.54	20.66	25.26	30	10.11	25.89	-0.63
5775	80	ac	SDM	NSS3	23.55	23.92	23.96	28.59	30	5.34	30.00	-1.41

Table 8. Conducted Output Power, Test Results

Electromagnetic Compatibility Criteria for Intentional Radiators

§15.407(a)(3) Maximum Power Spectral Density

Test Requirements: §15.407(a)(3): In addition, the maximum power spectral density shall not exceed 30 dBm in any 500-kHz band.

If transmitting antennas of directional gain greater than 6 dBi are used, both the maximum conducted output power and the maximum power spectral density shall be reduced by the amount in dB that the directional gain of the antenna exceeds 6 dBi. However, fixed point-to-point U-NII devices operating in this band may employ transmitting antennas with directional gain greater than 6 dBi without any corresponding reduction in transmitter conducted power.

Test Procedure: The EUT was connected to a spectrum analyzer through a cable and attenuator. Measurements were taken with the EUT set to transmit continuously on its low, mid, and high channels. Its power was measured according KDB 789033 D02 General UNII Test Procedures v01. A 1 MHz RBW was used during testing, as this provides a worst-case scenario.

The antenna gain was calculated based on whether the data was correlated or not per KDB 662911. For b and g mode the data is correlated and thus the gain is the array gain of all three antennas. For n mode the data is completely uncorrelated and thus the gain is the single antenna gain.

Test Results: The EUT as tested is compliant with the requirements of this section.

Test Engineer(s): Hadid Jones

Test Date(s): 10/14/16

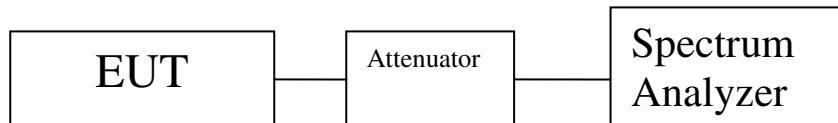

Frequency (MHz)	BW (MHz)	802.11 mode	Diversity Scheme	NSS	Port 1 PWR (dBm)	Port 2 PWR (dBm)	Port 2 PWR (dBm)	□ PWR P1,P2,P3 (dBm)	Limit (dBm)	Gain-pk (dBm)	Final Limit (dBm)	Margin (dB)
5745	20	a	CDD	NSS1	8.54	8.70	8.40	13.32	30	10.11	25.89	-12.57
5745	20	ac	CDD	NSS1	8.54	8.13	8.41	13.14	30	10.11	25.89	-12.75
5745	20	ac	SDM	NSS3	12.83	13.11	12.72	17.66	30	5.34	30.00	-12.34
5745	20	n	CDD	NSS1	8.19	8.49	7.99	13.00	30	10.11	25.89	-12.89
5745	20	n	SDM	NSS3	12.75	13.09	12.88	17.68	30	5.34	30.00	-12.32
5805	20	a	CDD	NSS1	8.67	9.24	8.54	13.60	30	10.11	25.89	-12.29
5805	20	ac	CDD	NSS1	8.21	8.11	8.29	12.97	30	10.11	25.89	-12.92
5805	20	ac	SDM	NSS3	12.50	11.87	11.98	16.90	30	5.34	30.00	-13.10
5805	20	n	CDD	NSS1	8.38	8.17	8.27	13.05	30	10.11	25.89	-12.84
5805	20	n	SDM	NSS3	12.23	11.86	11.67	16.70	30	5.34	30.00	-13.30
5825	20	a	CDD	NSS1	8.65	8.57	8.41	13.31	30	10.11	25.89	-12.58
5825	20	ac	CDD	NSS1	8.15	8.71	8.42	13.20	30	10.11	25.89	-12.69
5825	20	ac	SDM	NSS3	12.12	12.11	11.87	16.81	30	5.34	30.00	-13.19
5825	20	n	CDD	NSS1	8.37	8.01	8.13	12.94	30	10.11	25.89	-12.95
5825	20	n	SDM	NSS3	12.26	12.35	11.98	16.97	30	5.34	30.00	-13.03
5755	40	ac	CDD	NSS1	5.82	5.78	5.59	10.50	30	10.11	25.89	-15.39
5755	40	ac	SDM	NSS3	10.20	10.58	10.25	15.12	30	5.34	30.00	-14.88
5755	40	n	CDD	NSS1	5.94	5.76	5.63	10.55	30	10.11	25.89	-15.34
5755	40	n	SDM	NSS3	10.13	10.36	10.73	15.18	30	5.34	30.00	-14.82
5795	40	ac	CDD	NSS1	5.74	6.13	5.62	10.61	30	10.11	25.89	-15.28
5795	40	ac	SDM	NSS3	9.62	9.94	9.12	14.34	30	5.34	30.00	-15.66
5795	40	n	CDD	NSS1	5.88	5.61	5.27	10.36	30	10.11	25.89	-15.53
5795	40	n	SDM	NSS3	9.37	10.10	9.17	14.34	30	5.34	30.00	-15.66
5775	80	ac	CDD	NSS1	2.77	2.48	4.22	7.99	30	10.11	25.89	-17.90
5775	80	ac	SDM	NSS3	6.20	6.23	6.57	11.11	30	5.34	30.00	-18.89

Table 9. Power Spectral Density, Test Results

Electromagnetic Compatibility Criteria for Intentional Radiators

§15.407(b)(4) & (6 – 7) Undesirable Emissions

Test Requirements: § 15.407(b)(4): All emissions shall be limited to a level of -27 dBm/MHz at 75 MHz or more above or below the band edge increasing linearly to 10 dBm/MHz at 25 MHz above or below the band edge, and from 25 MHz above or below the band edge increasing linearly to a level of 15.6 dBm/MHz at 5 MHz above or below the band edge, and from 5 MHz above or below the band edge increasing linearly to a level of 27 dBm/MHz at the band edge.

§ 15.407(b)(6): Unwanted emissions below 1 GHz must comply with the general field strength limits set forth in Section 15.209. Further, any U-NII devices using an AC power line are required to comply also with the conducted limits set forth in Section 15.207.

§ 15.407(b)(7): The provisions of Section 15.205 of this part apply to intentional radiators operating under this section.

Test Procedure: The EUT was placed on a non-conducting stand on a turntable in a chamber. To find the maximum emission the EUT was set to transmit on low, mid, and high channels. Additionally, the turntable was rotated 360 degrees, the EUT was oriented through its three orthogonal axes, and the receive antenna height was varied in order to maximize emissions.

For frequencies from 30 MHz to 1 GHz, measurements were first made using a peak detector with a 100 kHz resolution bandwidth. Emissions which exceeded the limits were re-measured using a quasi-peak detector with a 120 kHz resolution bandwidth.

Above 1 GHz, measurements were made pursuant the method described in FCC KDB 789033 D02 General UNII Test Procedure New Rules v01. The equation, $EIRP = E + 20 \log D - 104.8$ was used to convert field strength to EIRP (E = field strength (dB μ V/m) and D = Reference measurement distance).

As an alternative, according to FCC KDB 789033 D02 General UNII Test Procedure New Rules v01, all emissions above 1 GHz that comply with the peak and average limits of 15.209 satisfy the requirements of unwanted emissions in 15.407.

Test Results: For below 1 GHz, the EUT was compliant with the requirements of this section.

For above 1 GHz, the EUT was compliant with the requirements of this section.

Only the noise floor was observed above 7GHz.

Test Engineer(s): Hadid Jones

Test Date(s): 10/14/16

Radiated Spurious Emissions, 30 MHz – 1 GHz

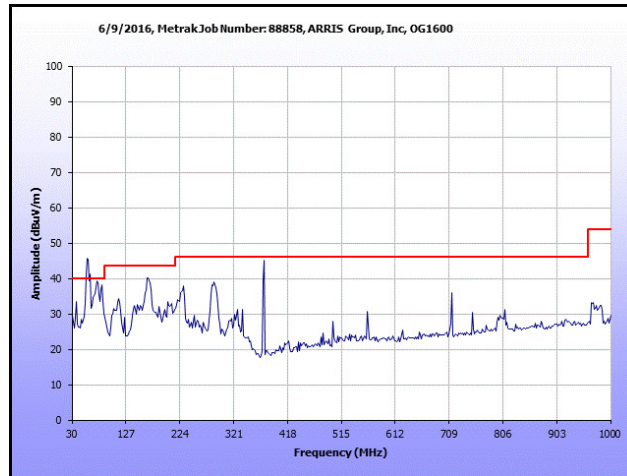

Plot 1. Radiated Spurious Emissions, 30 MHz – 1 GHz, Radio Off

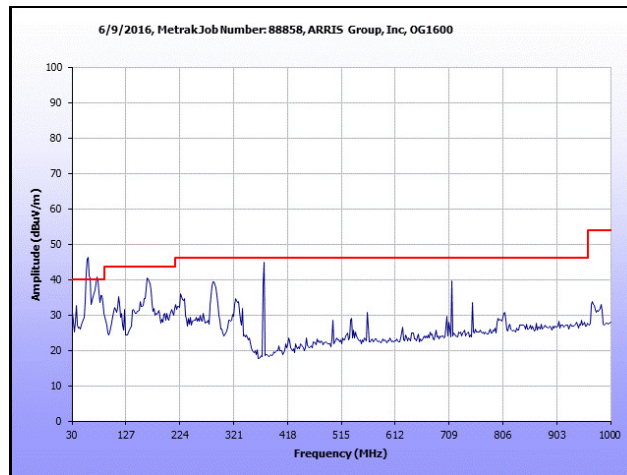

Plot 2. Radiated Spurious Emissions, 30 MHz – 1 GHz, Radio On

Note: The spurious emissions were not due to the operation of the radio but a result of the digital circuitry instead.

Radiated Spurious Emissions 1-18GHz

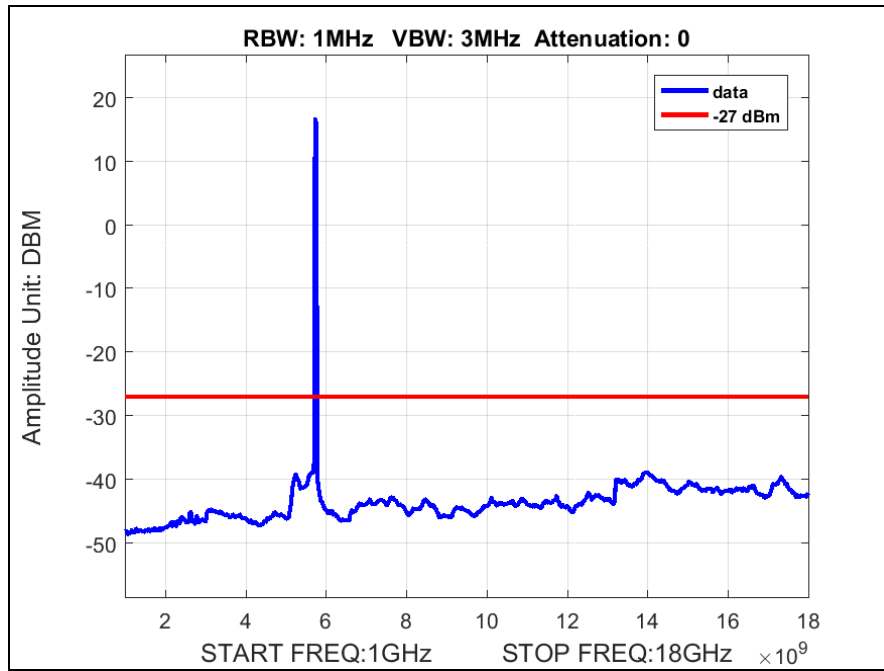

Plot 3. Radiated Spurious Emissions, 802.11a 20 MHz, Low Channel, 1 GHz – 18 GHz

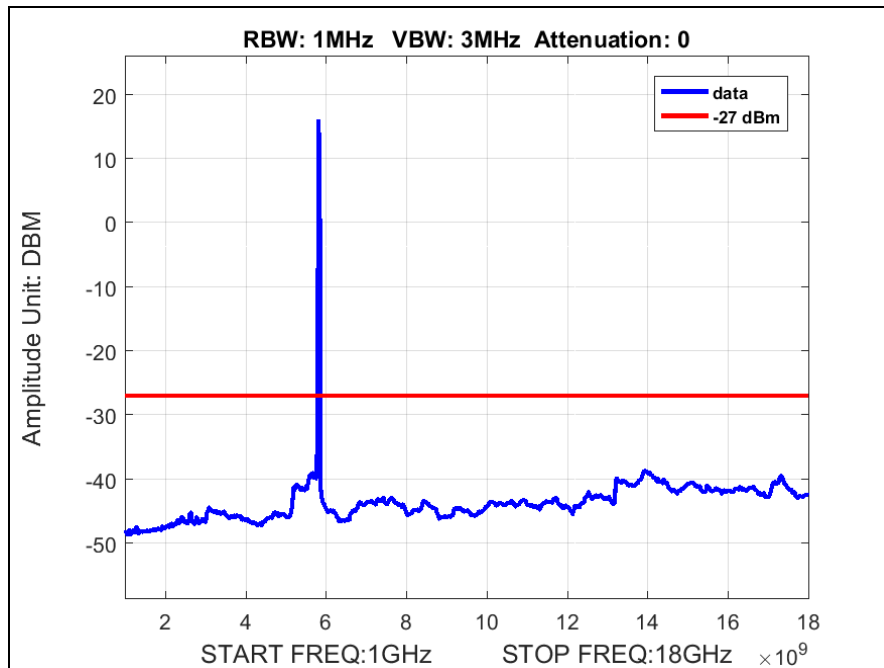

Plot 4. Radiated Spurious Emissions, 802.11a 20 MHz, High Channel, 1 GHz – 18 GHz

Radiated Spurious Emissions, 802.11ac 20 MHz

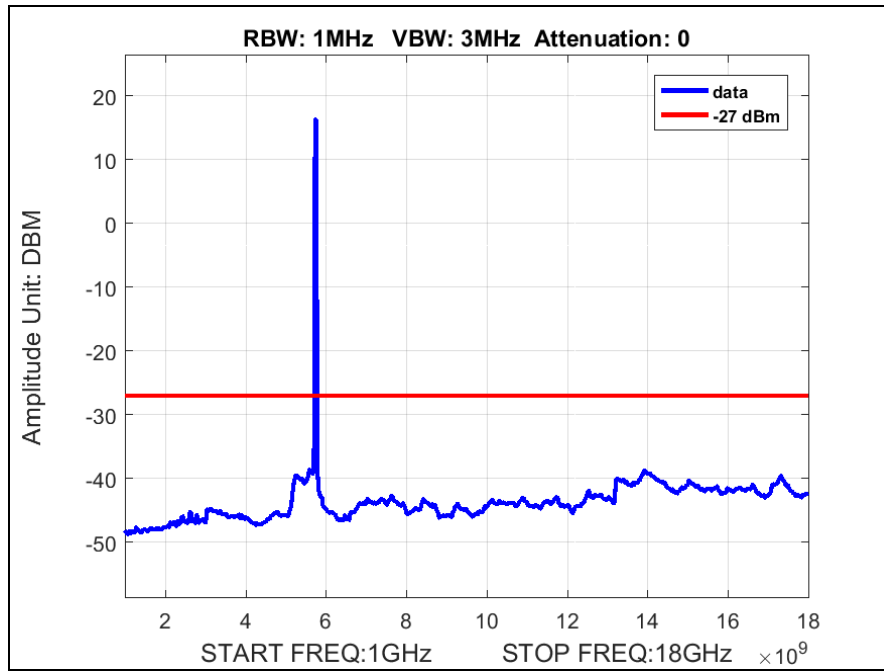

Plot 5. Radiated Spurious Emissions, 802.11ac 20 MHz, Low Channel, 1 GHz – 18 GHz

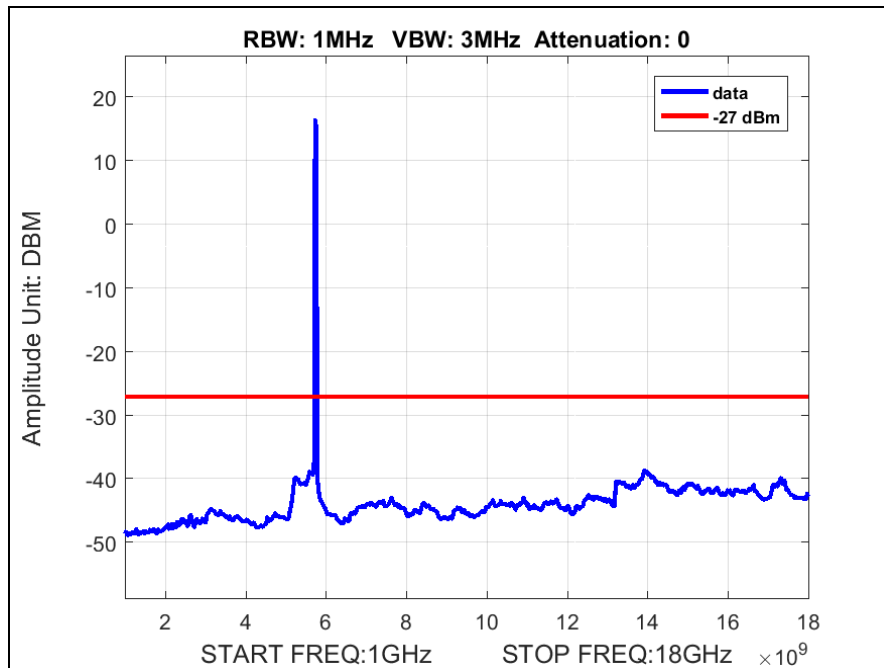

Plot 6. Radiated Spurious Emissions, 802.11ac 20 MHz, Low Channel, 1 GHz – 18 GHz

Radiated Spurious Emissions, 802.11ac 40 MHz

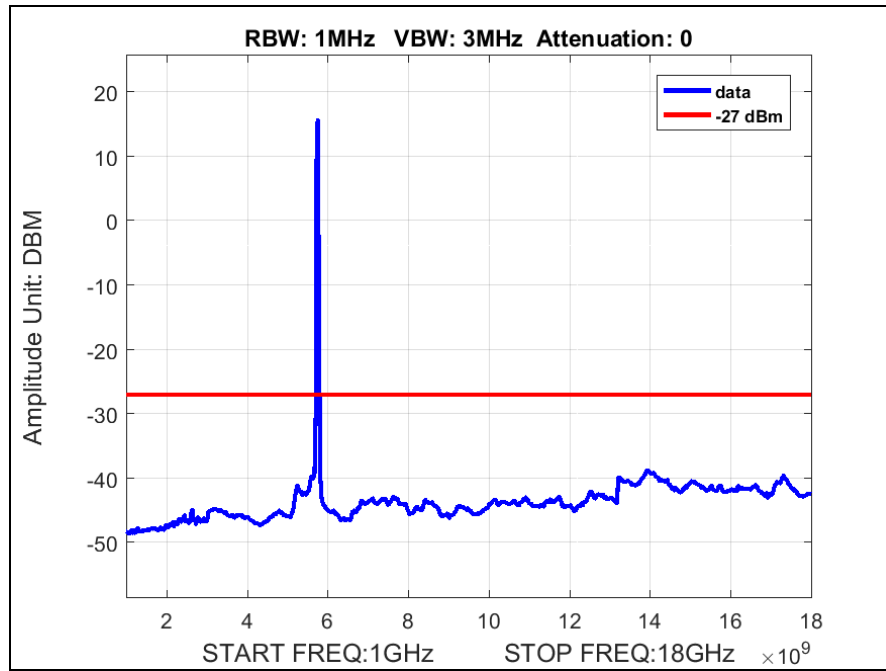

Plot 7. Radiated Spurious Emissions, 802.11ac 40 MHz, Low Channel, 1 GHz – 18 GHz

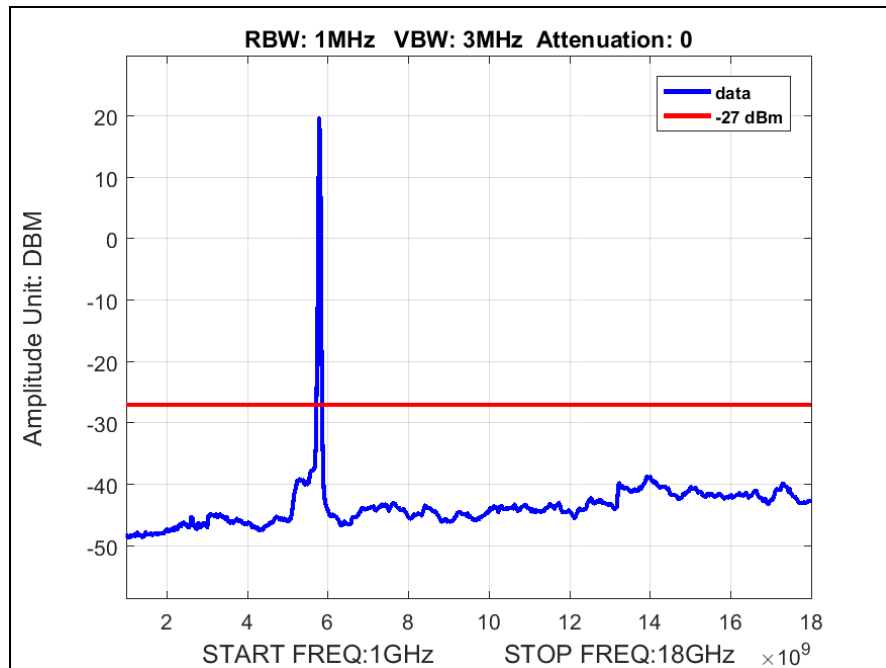

Plot 8. Radiated Spurious Emissions, 802.11ac 40 MHz, High Channel, 1 GHz – 18 GHz

Radiated Spurious Emissions, 802.11ac 80 MHz

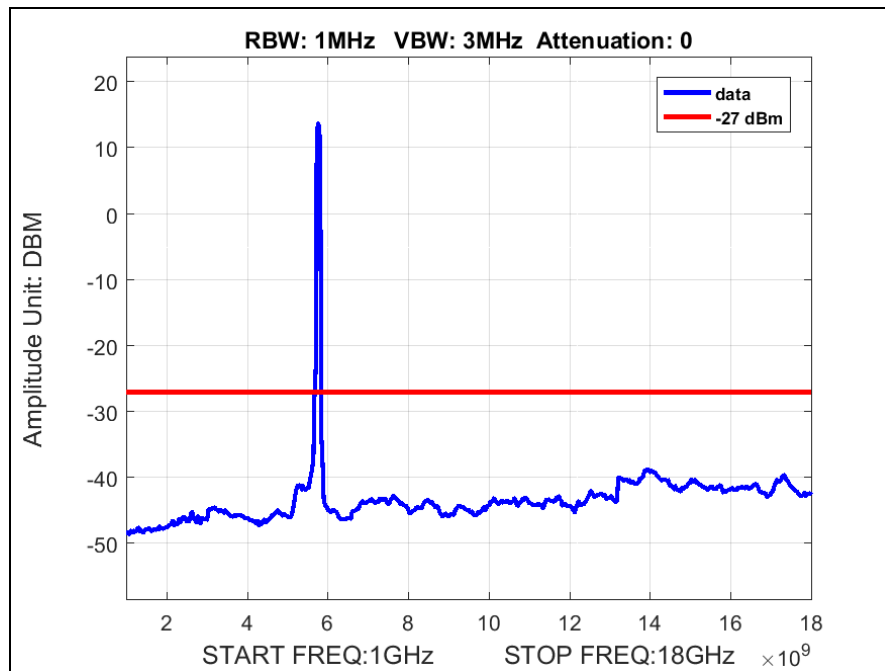

Plot 9. Radiated Spurious Emissions, 802.11ac 80 MHz, 1 GHz – 18 GHz

Radiated Spurious Emissions, 802.11n 20 MHz

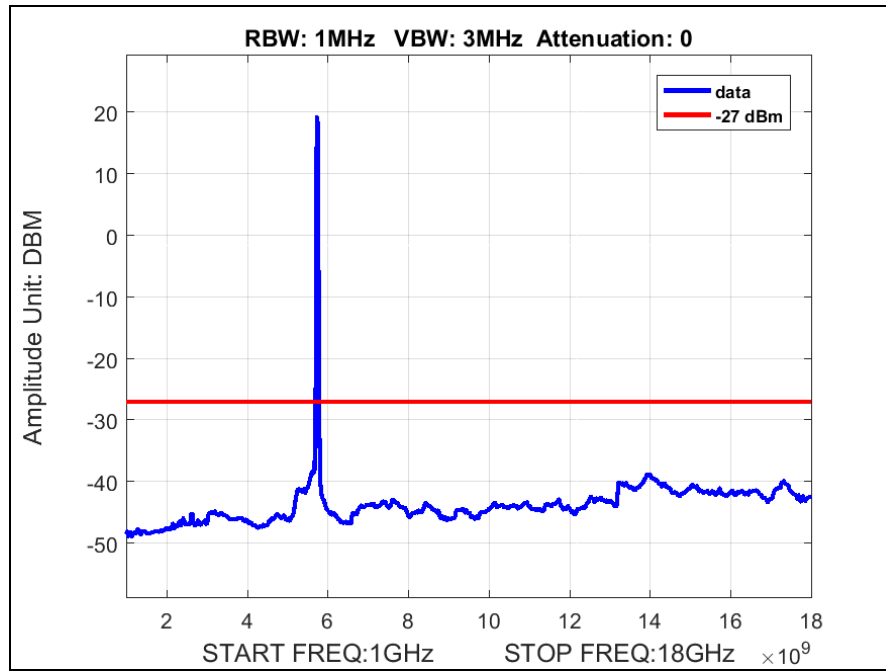

Plot 10. Radiated Spurious Emissions, 802.11n 20 MHz, Low Channel, 1 GHz – 18 GHz

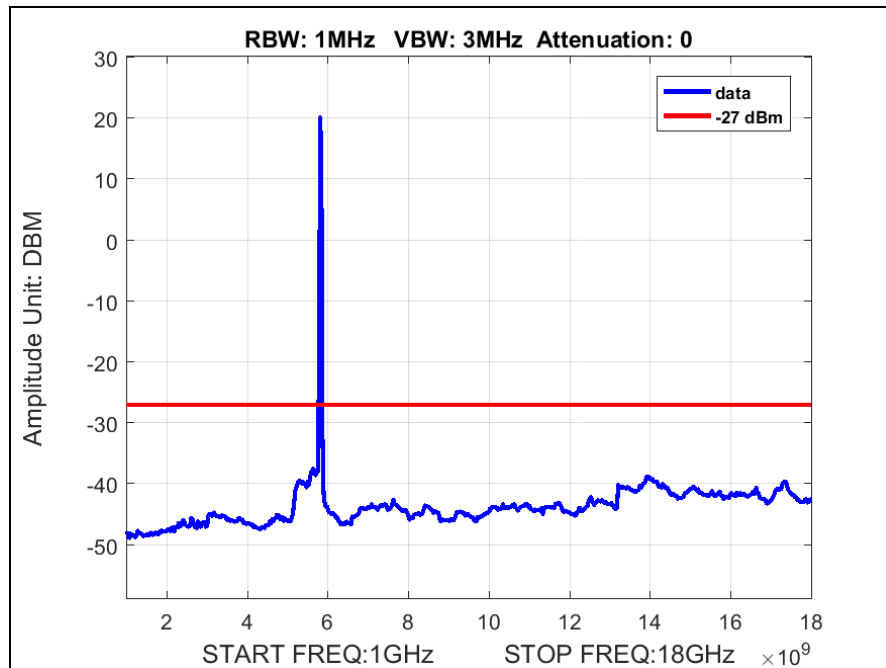

Plot 11. Radiated Spurious Emissions, 802.11n 20 MHz, High Channel, 1 GHz – 18 GHz

Radiated Spurious Emissions, 802.11n 40 MHz

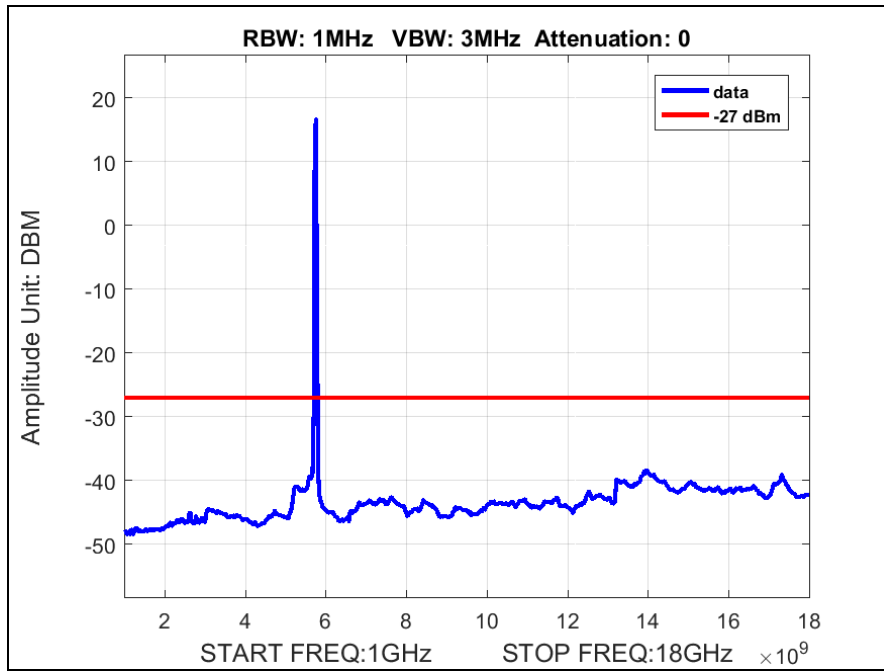

Plot 12. Radiated Spurious Emissions, 802.11n 40 MHz, Low Channel, 1 GHz – 18 GHz

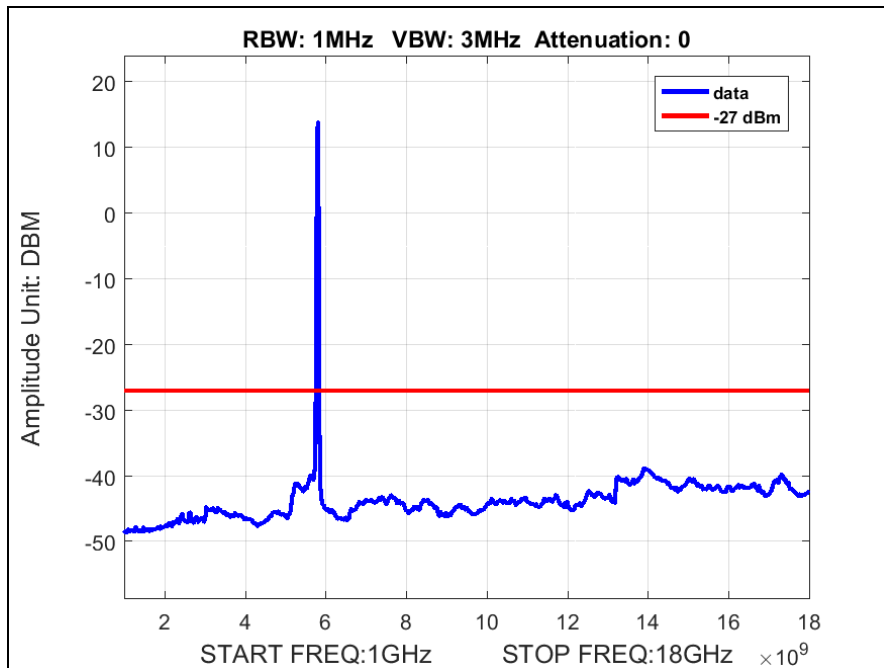

Plot 13. Radiated Spurious Emissions, 802.11n 40 MHz, High Channel, 1 GHz – 18 GHz

Radiated Band Edge, 802.11a 20 MHz

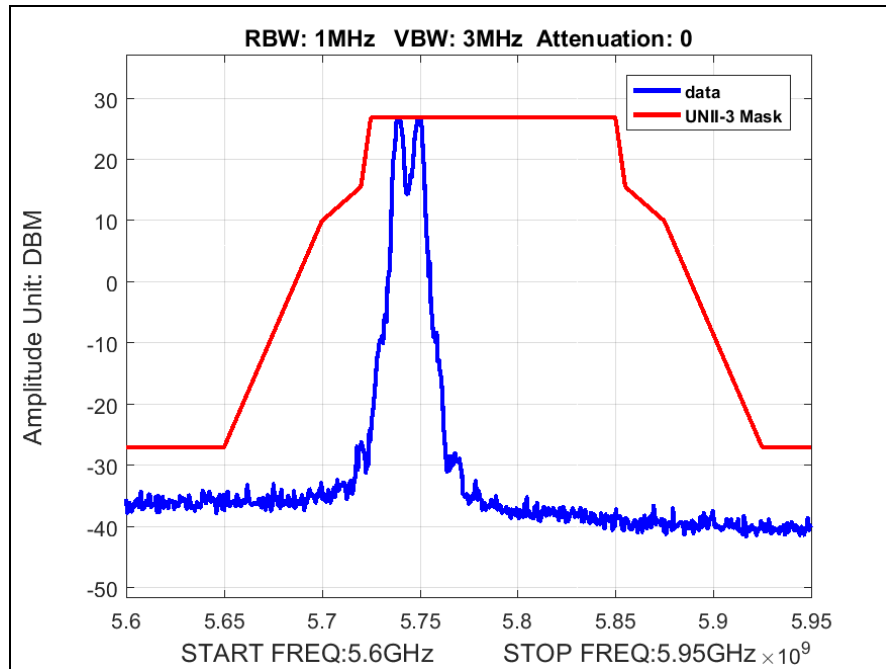

Plot 14. Radiated Band Edge, 802.11a 20 MHz, Low Channel

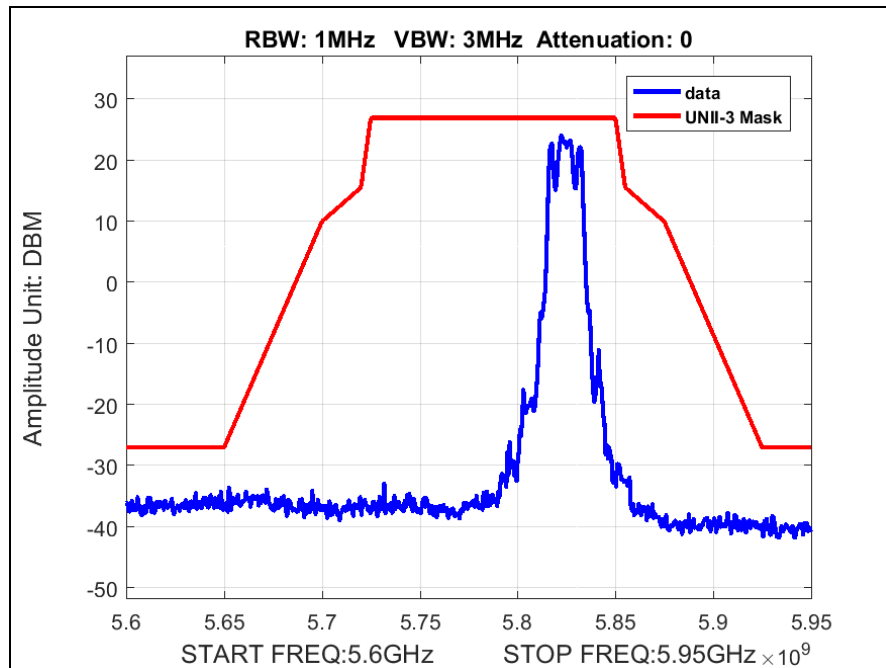

Plot 15. Radiated Band Edge, 802.11a 20 MHz, High Channel

Radiated Band Edge, 802.11ac 20 MHz

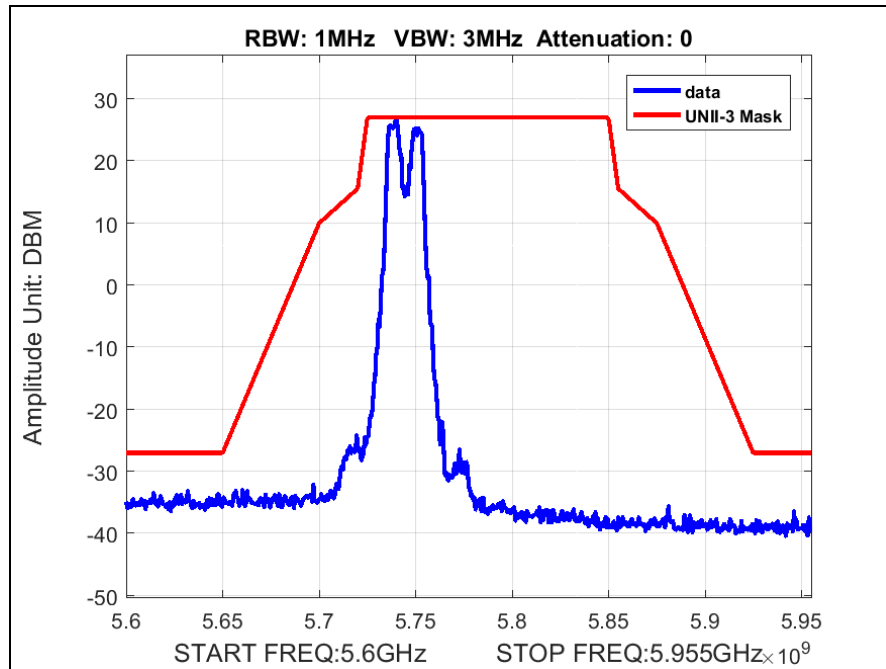

Plot 16. Radiated Band Edge, 802.11ac 20 MHz, Low Channel

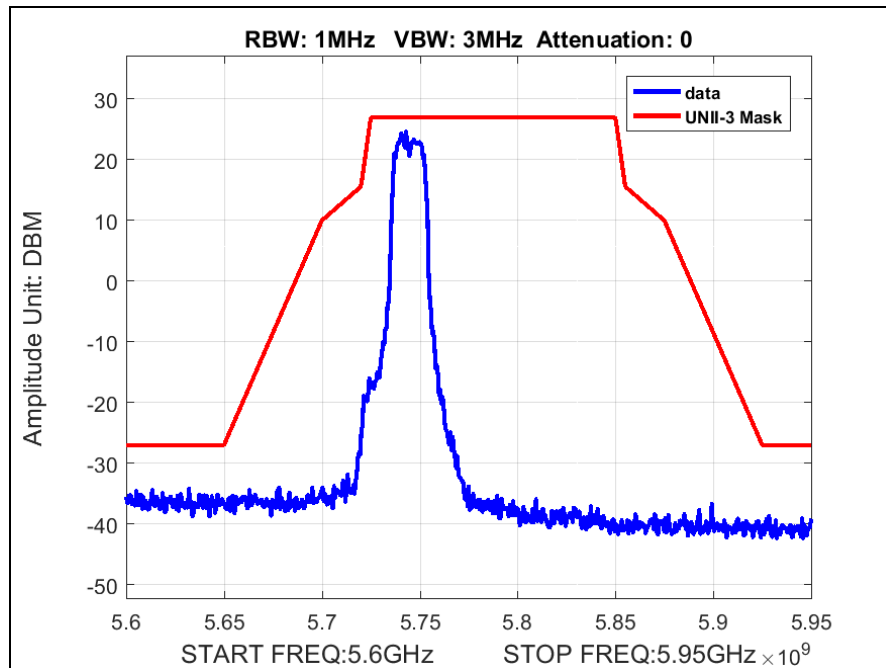

Plot 17. Radiated Band Edge, 802.11ac 20 MHz, Low Channel

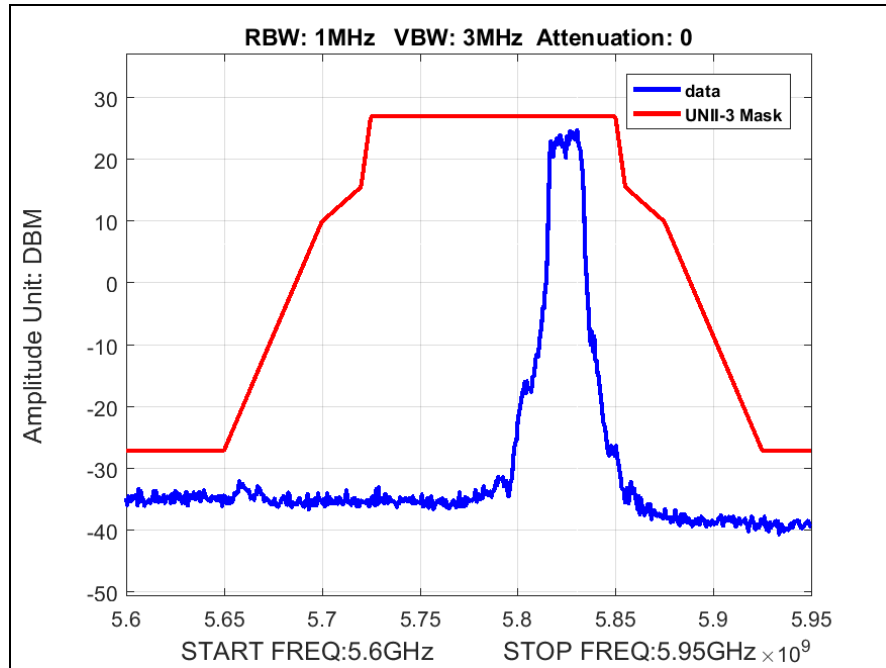

Plot 18. Radiated Band Edge, 802.11ac 20 MHz, High Channel

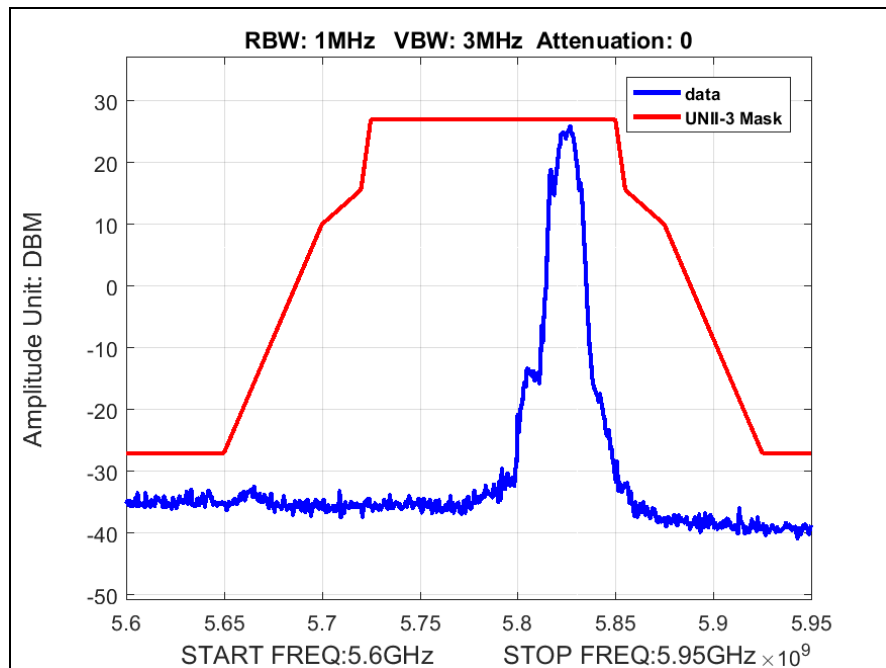

Plot 19. Radiated Band Edge, 802.11ac 20 MHz, High Channel

Radiated Band Edge, 802.11ac 40 MHz

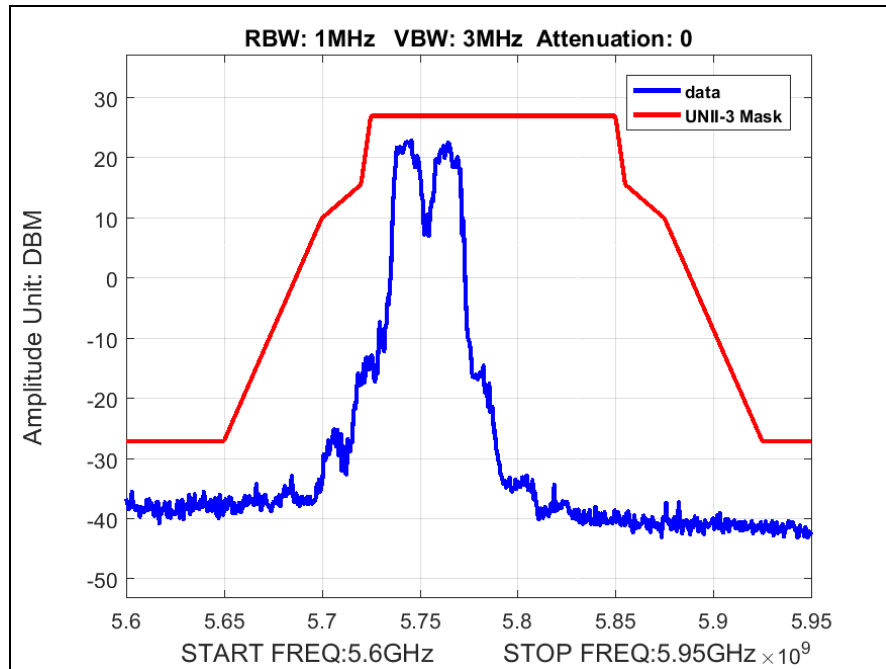

Plot 20. Radiated Band Edge, 802.11ac 40 MHz, Low Channel

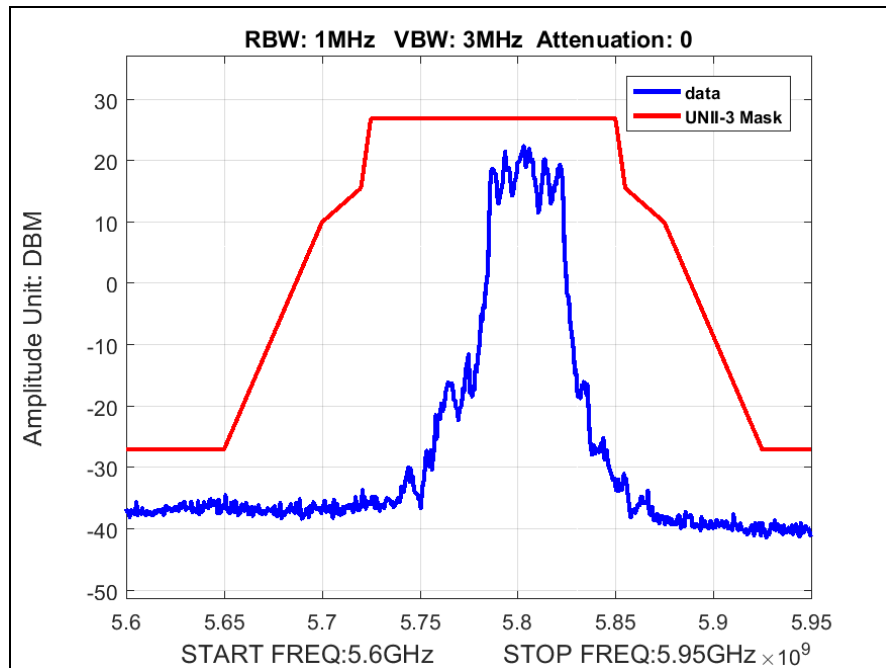

Plot 21. Radiated Band Edge, 802.11ac 40 MHz, High Channel

Radiated Band Edge, 802.11ac 80 MHz

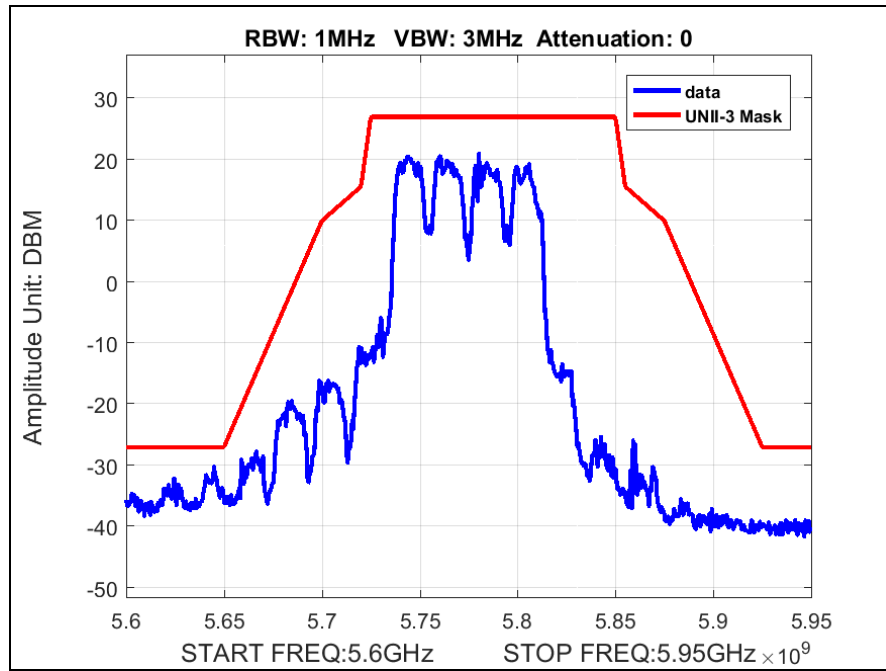

Plot 22. Radiated Band Edge, 802.11ac 80 MHz

Radiated Band Edge, 802.11n 20 MHz

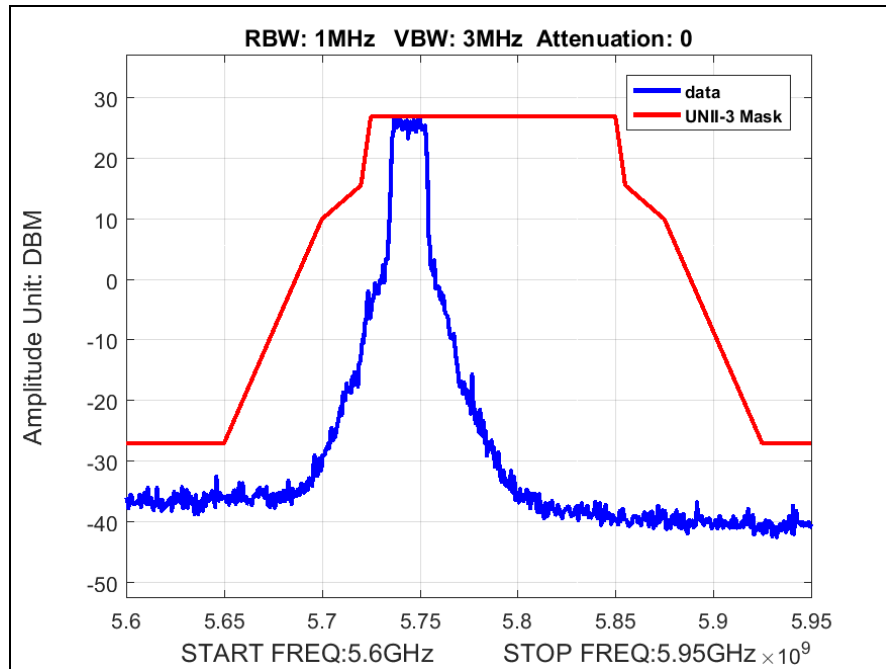

Plot 23. Radiated Band Edge, 802.11n 20 MHz, Low Channel

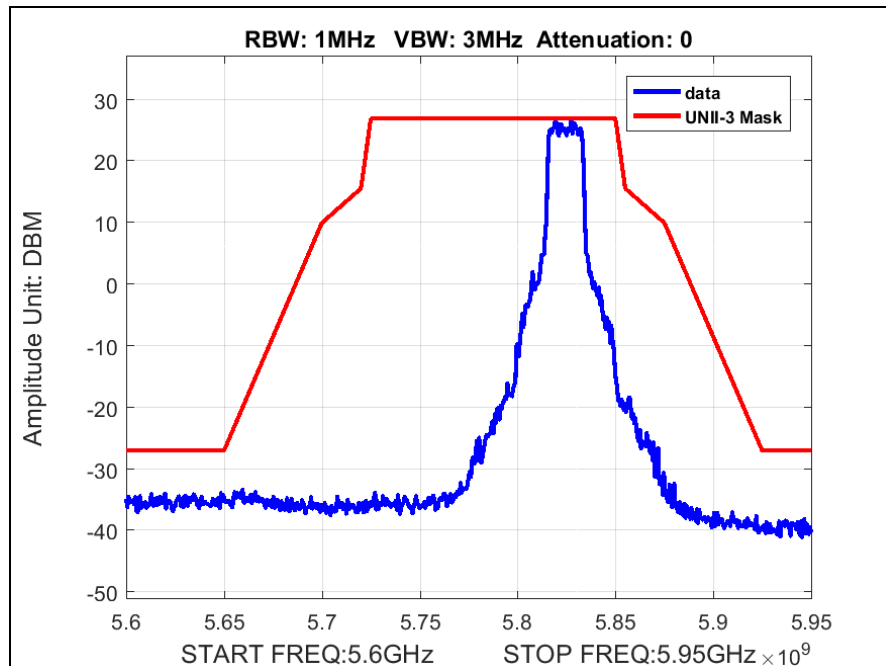

Plot 24. Radiated Band Edge, 802.11n 20 MHz, High Channel

Radiated Band Edge, 802.11n 40 MHz

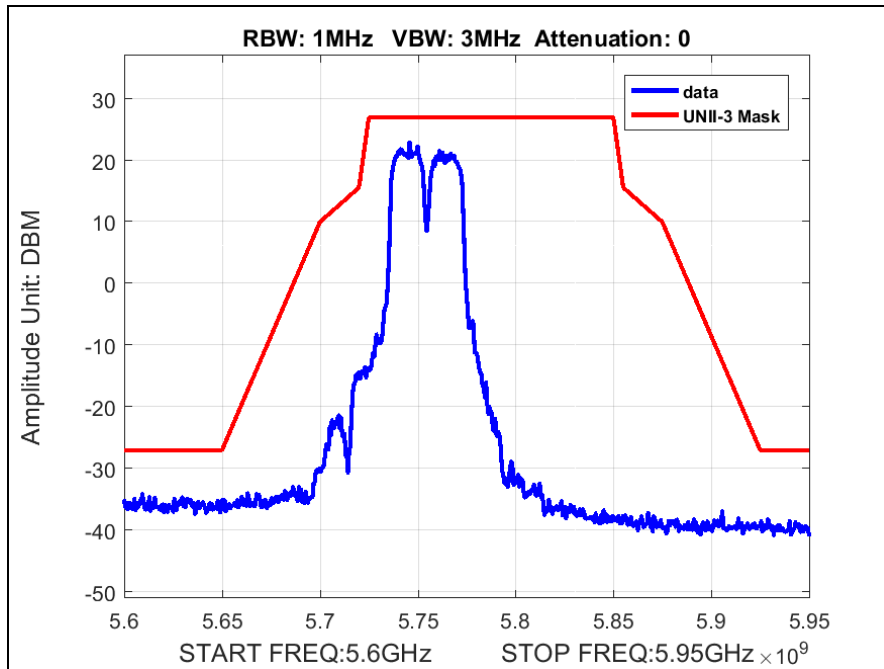

Plot 25. Radiated Band Edge, 802.11n 40 MHz, Low Channel

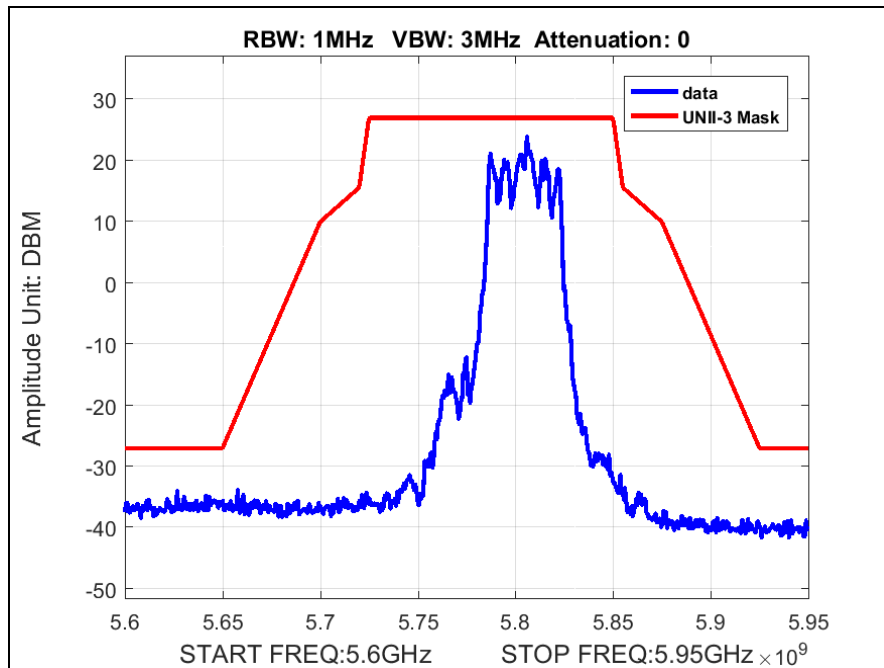

Plot 26. Radiated Band Edge, 802.11n 40 MHz, High Channel

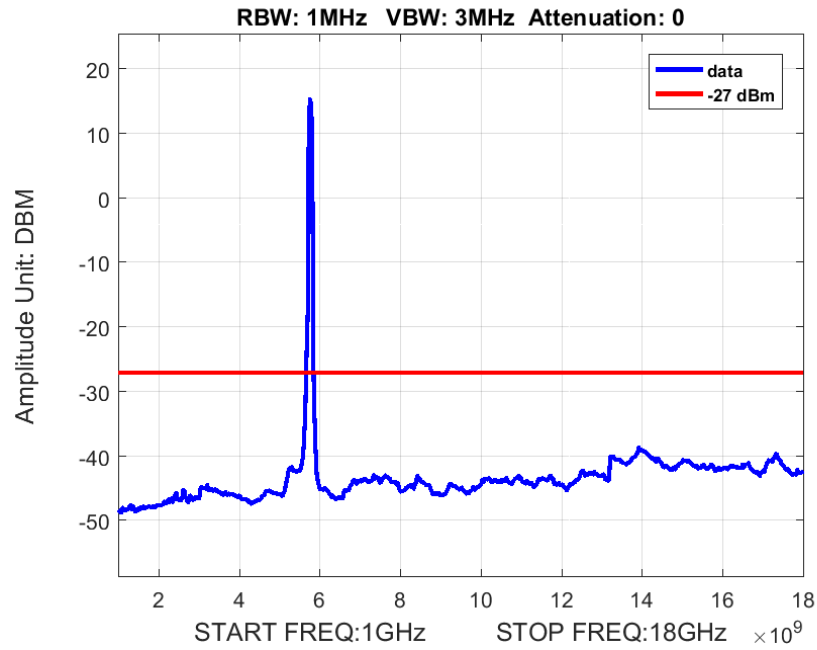

Plot 27. Radiated Spurious Emissions, 1-18GHz, 802.11ac 80 MHz, Worse Case

Electromagnetic Compatibility Criteria for Intentional Radiators

§ 15.407(b)(6) Conducted Emissions

Test Requirement(s): § 15.407 (b)(6): Any U-NII devices using an AC power line are required to comply also with the conducted limits set forth in §15.207.

§ 15.207 (a): For an intentional radiator that is designed to be connected to the public utility (AC) power line, the radio frequency voltage that is conducted back onto the AC power line on any frequency or frequencies, within the band 150 kHz to 30MHz, shall not exceed the limits in the following table, as measured using a 50 μ H/50 Σ line impedance stabilization network (LISN). Compliance with the provisions of this paragraph shall be based on the measurement of the radio frequency voltage between each power line and ground at the power terminal. The lower limit applies at the boundary between the frequency ranges.

Frequency range (MHz)	§ 15.207(a), Conducted Limit (dB μ V)	
	Quasi-Peak	Average
* 0.15- 0.45	66 – 56	56 - 46
0.45 - 0.5	56	46
0.5 - 30	60	50

Table 10. Conducted Limits for Intentional Radiators from FCC Part 15 § 15.207(a)

Test Procedure: The EUT was placed on a non-metallic table inside a screen room. The EUT was situated such that the back of the EUT was 0.4 m from one wall of the vertical ground plane, and the remaining sides of the EUT were no closer than 0.8 m from any other conductive surface. The EUT was powered from a 50 Ω /50 μ H Line Impedance Stabilization Network (LISN). The EMC receiver scanned the frequency range from 150 kHz to 30 MHz. Conducted Emissions measurements were made in accordance with ANSI C63.4-2014 "Methods and Measurements of Radio-Noise Emissions from Low-Voltage Electrical and Electronic Equipment in the Range of 9kHz to 40 GHz". Scans were performed with the transmitter on.

Test Results: The EUT was compliant with requirements of this section.

Test Engineer(s): Hadid Jones

Test Date(s): 10/14/16

15.207(a) Conducted Emissions Test Results

Frequency (MHz)	Uncorrected Meter Reading (dBμV) QP	Cable Loss (dB)	Corrected Measurement (dBμV) QP	Limit (dBμV) QP	Margin (dB) QP	Uncorrected Meter Reading (dBμV) Avg.	Cable Loss (dB)	Corrected Measurement (dBμV) AVG	Limit (dBμV) AVG	Margin (dB) AVG
0.156	58.46	0	58.46	66	-7.54	48.31	0	48.31	56	-7.69
0.456	55.19	0	55.19	56	-0.81	42.21	0	42.21	46	-3.79
1.26	47.16	0	47.16	56	-8.84	34.29	0	34.29	46	-11.71
6.76	38.33	0	38.33	56	-17.67	24.52	0	24.52	46	-21.48
13.46	33.52	0	33.52	56	-22.48	21.37	0	21.37	46	-24.63
24.77	21.34	0	21.34	56	-34.66	16.84	0	16.84	46	-29.16

Table 11. Conducted Emissions, 15.207(a), Phase Line, Test Results

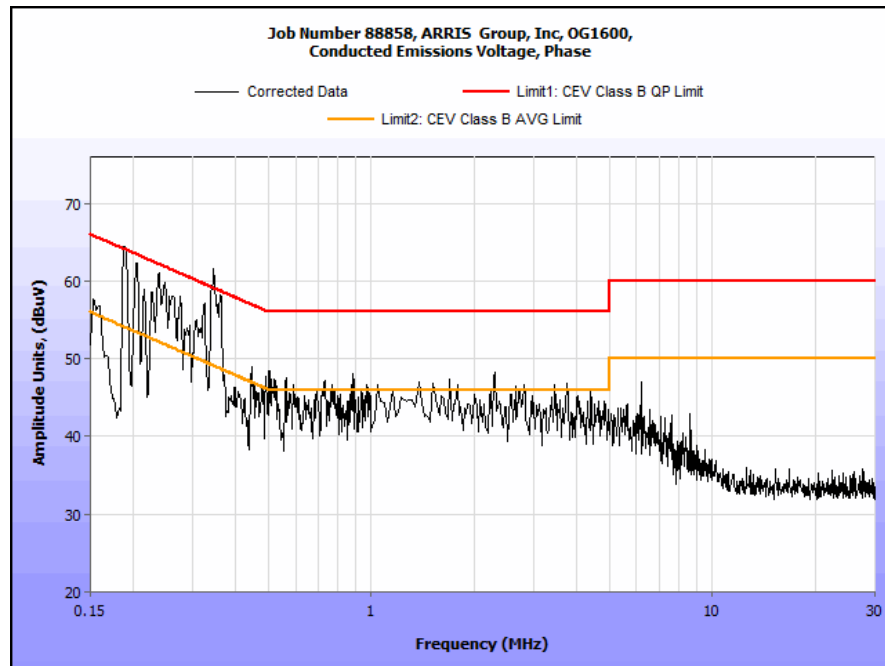

Plot 27. Conducted Emissions, 15.207(a), Phase Line

15.207(a) Conducted Emissions Test Results

Frequency (MHz)	Uncorrected Meter Reading (dB μ V) QP	Cable Loss (dB)	Corrected Measurement (dB μ V) QP	Limit (dB μ V) QP	Margin (dB) QP	Uncorrected Meter Reading (dB μ V) Avg.	Cable Loss (dB)	Corrected Measurement (dB μ V) AVG	Limit (dB μ V) AVG	Margin (dB) AVG
0.234	54.69	0	54.69	66	-11.31	41.28	0	41.28	56	-14.72
0.645	51.23	0	51.23	56	-4.77	40.19	0	40.19	46	-5.81
3.34	44.36	0	44.36	56	-11.64	32.49	0	32.49	46	-13.51
10.26	40.19	0	40.19	56	-15.81	29.84	0	29.84	46	-16.16
19.42	35.61	0	35.61	56	-20.39	24.12	0	24.12	46	-21.88
29.64	23.46	0	23.46	56	-32.54	14.28	0	14.28	46	-31.72

Table 12. Conducted Emissions, 15.207(a), Neutral Line, Test Results

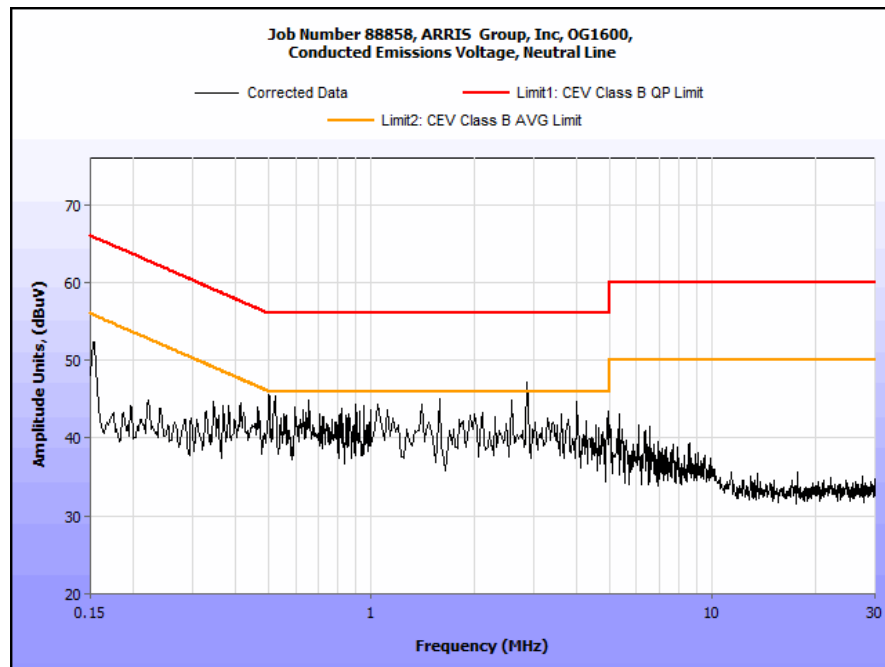

Plot 28. Conducted Emissions, 15.207(a), Neutral Line

Electromagnetic Compatibility Criteria for Intentional Radiators

§ 15.407(e) 6 dB Bandwidth

Test Requirements: § 15.407(e): Within the 5.725-5.85 GHz band, the minimum 6 dB bandwidth of U-NII devices shall be at least 500 kHz.

Test Procedure: The transmitter was set to low, mid, and high operating frequencies at the highest output power and connected to the spectrum analyzer through an attenuator. The bandwidth of the fundamental frequency was measured with the spectrum analyzer using a RBW approximately equal to 1% of the total emission bandwidth, VBW > RBW. The 6 dB Bandwidth was measured and recorded.

Test Results The 6 dB Bandwidth was compliant with the requirements of this section based on the fact that the occupied bandwidth is >> 500kHz.

Test Engineer(s): Hadid Jones

Test Date(s): 10/14/16

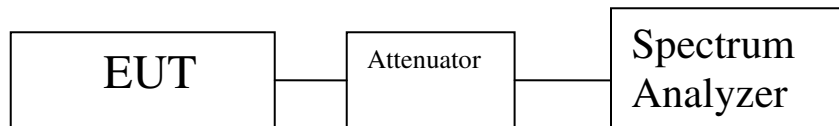

Mode	OBW
BW 20M_Ch 5745M_a mode r6 TP18.5	16.4319
BW 20M_Ch 5805M_a mode r6 TP18.5	16.4583
BW 20M_Ch 5825M_a mode r6 TP18.5	16.436
BW 20M_Ch 5745M_ac mode vt0 TP18.5	17.6322
BW 20M_Ch 5805M_ac mode vt0 TP18.5	17.6164
BW 20M_Ch 5825M_ac mode vt0 TP18.5	17.5905
BW 40M_Ch 5755M_ac mode vf0 TP19.5	36.0577
BW 40M_Ch 5795M_ac mode vf0 TP19.5	36.041
BW 80M_Ch 5775M_ac mode ve0 TP20.5	75.3833
BW 20M_Ch 5745M_n mode t0 TP18.5	17.6249
BW 20M_Ch 5805M_n mode t0 TP18.5	17.6035
BW 20M_Ch 5825M_n mode t0 TP18.5	17.6238
BW 40M_Ch 5755M_n mode f0 TP19.5	36.1016
BW 40M_Ch 5795M_n mode f0 TP19.5	36.1215

Table 13. 6 dB Occupied Bandwidth, Test Results

Electromagnetic Compatibility Criteria for Intentional Radiators

§ 15.407(f) Maximum Permissible Exposure

Test Requirement(s): §15.407(f): U-NII devices are subject to the radio frequency radiation exposure requirements specified in §1.1307(b), §2.1091 and §2.1093 of this chapter, as appropriate. All equipment shall be considered to operate in a “general population/uncontrolled” environment.

RF Exposure Requirements: §1.1307(b)(1) and §1.1307(b)(2): Systems operating under the provisions of this section shall be operated in a manner that ensures that the public is not exposed to radio frequency energy levels in excess of the Commission’s guidelines.

RF Radiation Exposure Limit: §1.1310: As specified in this section, the Maximum Permissible Exposure (MPE) Limit shall be used to evaluate the environmental impact of human exposure to radiofrequency (RF) radiation as specified in Sec. 1.1307(b), except in the case of portable devices which shall be evaluated according to the provisions of Sec. 2.1093 of this chapter.

MPE Limit: EUT’s operating frequencies @ 5725 - 5850 MHz; **Limit for Uncontrolled exposure: 1 mW/cm² or 10 W/m²**

Equation from page 18 of OET 65, Edition 97-01

$$S = PG / 4\pi R^2 \quad \text{or} \quad R = \sqrt{PG / 4\pi S}$$

where, S = Power Density (mW/cm²)
P = Power Input to antenna (mW)
G = Antenna Gain (numeric value)
R = Distance (cm)

Test Results:

FCC									
Frequency (MHz)	Con. Pwr. (dBm)	Con. Pwr. (mW)	Ant. Gain (dBi)	Ant. Gain numeric	Pwr. Density (mW/cm ²)	Limit (mW/cm ²)	Margin	Distance (cm)	Result
5755	29.53	897.429	5.34	3.42	0.61056	1	0.38944	20	Pass

The safe distance where Power Density is less than the MPE Limit listed above was found to be 20 cm.

IV. Test Equipment

Test Equipment

Calibrated test equipment utilized during testing was maintained in a current state of calibration per the requirements of ISO/IEC 17025:2005.

MET Asset #	Equipment	Manufacturer	Model	Last Cal Date	Cal Due Date
1T4751	ANTENNA - BILOG	SUNOL SCIENCES	JB6	2/26/2016	8/26/2017
1T4409	EMI RECEIVER	ROHDE & SCHWARZ	ESIB7	10/29/2014	10/29/2016
1T4818	COMB GENERATOR	COM-POWER	CGO-520	SEE NOTE	
1T4483	ANTENNA; HORN	ETS-LINDGREN	3117	10/8/2015	4/8/2017
1T4442	PRE-AMPLIFIER, MICROWAVE	MITEQ	AFS42-01001800-30-10P	SEE NOTE	
1T6658	SPECTRUM ANALYZER	AGILENT TECHNOLOGIES	E4407B	12/9/2015	12/9/2016
1T4745	ANTENNA, HORN	ETS-LINDGREN	3116	6/27/2015	12/27/2016
1T4752	PRE-AMPLIFIER	MITEQ	JS44-18004000-35-8P	SEE NOTE	
1T4300A	SEMI-ANECHOIC CHAMBER # 1 (FCC)	EMC TEST SYSTEMS	NONE	1/31/2014	01/31/2017
1T4504	SHIELDED ROOM	UNIVERSAL SHIELDING CORP	N/A	NOT REQUIRED	
1T4563	LISN (10 AMP)	SOLAR ELECTRONICS COMPANY	9322-50-R-10-BNC	8/27/2015	2/27/2017

Table 14. Test Equipment List

Note: Functionally tested equipment is verified using calibrated instrumentation at the time of testing.

V. Certification & User's Manual Information

Certification & User's Manual Information

K. Certification Information

The following is extracted from Title 47 of the Code of Federal Regulations, Part 2, Subpart I — Marketing of Radio frequency devices:

§ 2.801 Radio-frequency device defined.

As used in this part, a radio-frequency device is any device which in its operation is capable of Emitting radio-frequency energy by radiation, conduction, or other means. Radio- frequency devices include, but are not limited to:

- (a) The various types of radio communication transmitting devices described throughout this chapter.
- (b) *The incidental, unintentional and intentional radiators defined in Part 15 of this chapter.*
- (c) The industrial, scientific, and medical equipment described in Part 18 of this chapter.
- (d) Any part or component thereof which in use emits radio-frequency energy by radiation, conduction, or other means.

§ 2.803 Marketing of radio frequency devices prior to equipment authorization.

- (a) Except as provided elsewhere in this chapter, no person shall sell or lease, or offer for sale or lease (including advertising for sale or lease), or import, ship or distribute for the purpose of selling or leasing or offering for sale or lease, any radio frequency device unless:
 - (1) In the case of a device subject to certification, such device has been authorized by the Commission in accordance with the rules in this chapter and is properly identified and labeled as required by §2.925 and other relevant sections in this chapter; or
 - (2) In the case of a device that is not required to have a grant of equipment authorization issued by the Commission, but which must comply with the specified technical standards prior to use, such device also complies with all applicable administrative (including verification of the equipment or authorization under a Declaration of Conformity, where required), technical, labeling and identification requirements specified in this chapter.
- (d) Notwithstanding the provisions of paragraph (a) of this section, the offer for sale solely to business, commercial, industrial, scientific or medical users (but not an offer for sale to other parties or to end users located in a residential environment) of a radio frequency device that is in the conceptual, developmental, design or pre-production stage is permitted prior to equipment authorization or, for devices not subject to the equipment authorization requirements, prior to a determination of compliance with the applicable technical requirements *provided* that the prospective buyer is advised in writing at the time of the offer for sale that the equipment is subject to the FCC rules and that the equipment will comply with the appropriate rules before delivery to the buyer or to centers of distribution.

- (e)(1) Notwithstanding the provisions of paragraph (a) of this section, prior to equipment authorization or determination of compliance with the applicable technical requirements any radio frequency device may be operated, but not marketed, for the following purposes and under the following conditions:
- (i) *Compliance testing;*
 - (ii) Demonstrations at a trade show provided the notice contained in paragraph (c) of this section is displayed in a conspicuous location on, or immediately adjacent to, the device;
 - (iii) Demonstrations at an exhibition conducted at a business, commercial, industrial, scientific or medical location, but excluding locations in a residential environment, provided the notice contained in paragraphs (c) or (d) of this section, as appropriate, is displayed in a conspicuous location on, or immediately adjacent to, the device;
 - (iv) Evaluation of product performance and determination of customer acceptability, provided such operation takes place at the manufacturer's facilities during developmental, design or pre-production states; or
 - (v) Evaluation of product performance and determination of customer acceptability where customer acceptability of a radio frequency device cannot be determined at the manufacturer's facilities because of size or unique capability of the device, provided the device is operated at a business, commercial, industrial, scientific or medical user's site, but not at a residential site, during the development, design or pre-production stages.
- (e)(2) For the purpose of paragraphs (e)(1)(iv) and (e)(1)(v) of this section, the term *manufacturer's facilities* includes the facilities of the party responsible for compliance with the regulations and the manufacturer's premises, as well as the facilities of other entities working under the authorization of the responsible party in connection with the development and manufacture, but not the marketing, of the equipment.
- (f) For radio frequency devices subject to verification and sold solely to business, commercial, industrial, scientific and medical users (excluding products sold to other parties or for operation in a residential environment), parties responsible for verification of the devices shall have the option of ensuring compliance with the applicable technical specifications of this chapter at each end user's location after installation, provided that the purchase or lease agreement includes a proviso that such a determination of compliance be made and is the responsibility of the party responsible for verification of the equipment.

Certification & User's Manual Information

The following is extracted from Title 47 of the Code of Federal Regulations, Part 2, Subpart J — Equipment Authorization Procedures:

§ 2.901 Basis and Purpose

- (a) In order to carry out its responsibilities under the Communications Act and the various treaties and international regulations, and in order to promote efficient use of the radio spectrum, the Commission has developed technical standards for radio frequency equipment and parts or components thereof. The technical standards applicable to individual types of equipment are found in that part of the rules governing the service wherein the equipment is to be operated.¹ *In addition to the technical standards provided, the rules governing the service may require that such equipment be verified by the manufacturer or importer, be authorized under a Declaration of Conformity, or receive an equipment authorization from the Commission by one of the following procedures: certification or registration.*
- (b) The following sections describe the verification procedure, the procedure for a Declaration of Conformity, and the procedures to be followed in obtaining certification from the Commission and the conditions attendant to such a grant.

§ 2.907 Certification.

- (a) Certification is an equipment authorization issued by the Commission, based on representation and test data submitted by the applicant.
- (b) Certification attaches to all units subsequently marketed by the grantee which are identical (see Section 2.908) to the sample tested except for permissive changes or other variations authorized by the Commission pursuant to Section 2.1043.

¹ In this case, the equipment is subject to the rules of Part 15. More specifically, the equipment falls under Subpart B (of Part 15), which deals with unintentional radiators.

Certification & User's Manual Information

§ 2.948 Description of measurement facilities.

- (a) Each party making measurements of equipment that is subject to an equipment authorization under Part 15 or Part 18 of this chapter, regardless of whether the measurements are filed with the Commission or kept on file by the party responsible for compliance of equipment marketed within the U.S. or its possessions, shall compile a description of the measurement facilities employed.
 - (1) If the measured equipment is subject to the verification procedure, the description of the measurement facilities shall be retained by the party responsible for verification of the equipment.
 - (i) *If the equipment is verified through measurements performed by an independent laboratory, it is acceptable for the party responsible for verification of the equipment to rely upon the description of the measurement facilities retained by or placed on file with the Commission by that laboratory. In this situation, the party responsible for the verification of the equipment is not required to retain a duplicate copy of the description of the measurement facilities.*
 - (ii) If the equipment is verified based on measurements performed at the installation site of the equipment, no specific site calibration data is required. It is acceptable to retain the description of the measurement facilities at the site at which the measurements were performed.
 - (2) If the equipment is to be authorized by the Commission under the certification procedure, the description of the measurement facilities shall be filed with the Commission's Laboratory in Columbia, Maryland. The data describing the measurement facilities need only be filed once but must be updated as changes are made to the measurement facilities or as otherwise described in this section. At least every three years, the organization responsible for filing the data with the Commission shall certify that the data on file is current.

Certification & User's Manual Information

Label and User's Manual Information

The following is extracted from Title 47 of the Code of Federal Regulations, Part 15, Subpart A — General:

§ 15.19 Labeling requirements.

(a) *In addition to the requirements in Part 2 of this chapter, a device subject to certification or verification shall be labeled as follows:*

- (1) Receivers associated with the operation of a licensed radio service, e.g., FM broadcast under Part 73 of this chapter, land mobile operation under Part 90, etc., shall bear the following statement in a conspicuous location on the device:

This device complies with Part 15 of the FCC Rules. Operation is subject to the condition that this device does not cause harmful interference.

- (2) A stand-alone cable input selector switch, shall bear the following statement in a conspicuous location on the device:

This device is verified to comply with Part 15 of the FCC Rules for use with cable television service.

- (3) All other devices shall bear the following statement in a conspicuous location on the device:

This device complies with Part 15 of the FCC Rules. Operation is subject to the following two conditions: (1) This device may not cause harmful interference, and (2) this device must accept any interference received, including interference that may cause undesired operation.

- (4) Where a device is constructed in two or more sections connected by wires and marketed together, the statement specified under paragraph (a) of this section is required to be affixed only to the main control unit.

- (5) When the device is so small or for such use that it is not practicable to place the statement specified under paragraph (a) of this section on it, the information required by this paragraph shall be placed in a prominent location in the instruction manual or pamphlet supplied to the user or, alternatively, shall be placed on the container in which the device is marketed. However, the FCC identifier or the unique identifier, as appropriate, must be displayed on the device.

§ 15.21 Information to user.

The users manual or instruction manual for an intentional or unintentional radiator shall caution the user that changes or modifications not expressly approved by the party responsible for compliance could void the user's authority to operate the equipment.

Verification & User's Manual Information

The following is extracted from Title 47 of the Code of Federal Regulations, Part 15, Subpart B — Unintentional Radiators:

§ 15.105 Information to the user.

- (a) For a Class A digital device or peripheral, the instructions furnished the user shall include the following or similar statement, placed in a prominent location in the text of the manual:

Note: This equipment has been tested and found to comply with the limits for a Class A digital device, pursuant to Part 15 of the FCC Rules. These limits are designed to provide reasonable protection against harmful interference when the equipment is operated in a commercial environment. This equipment generates, uses, and can radiate radio frequency energy and, if not installed and used in accordance with the instruction manual, may cause harmful interference to radio communications. Operation of this equipment in a residential area is likely to cause harmful interference in which case the user will be required to correct the interference at own expense.

- (b) For a Class B digital device or peripheral, the instructions furnished the user shall include the following or similar statement, placed in a prominent location in the text of the manual:

Note: This equipment has been tested and found to comply with the limits for a Class B digital device, pursuant to Part 15 of the FCC Rules. These limits are designed to provide reasonable protection against harmful interference when the equipment is operated in a residential environment. This equipment generates, uses, and can radiate radio frequency energy and, if not installed and used in accordance with the instruction manual, may cause harmful interference to radio communications. However, there is no guarantee that interference will not occur in a particular installation. If this equipment does cause harmful interference to radio or television reception, which can be determined by turning the equipment off and on, the user is encouraged to try to correct the interference by one or more of the following measures:

- Reorient or relocate the receiving antenna.
- Increase the separation between the equipment and receiver.
- Connect the equipment into an outlet on a circuit different from that to which the receiver is connected.
- Consult the dealer or an experienced radio/TV technician for help.

End of Report