



MET Laboratories, Inc. *Safety Certification - EMI - Telecom Environmental Simulation*

914 WEST PATAPSCO AVENUE • BALTIMORE, MARYLAND 21230-3432 • PHONE (410) 354-3300 • FAX (410) 354-3313
33439 WESTERN AVENUE • UNION CITY, CALIFORNIA 94587 • PHONE (510) 489-6300 • FAX (510) 489-6372
3162 BELICK STREET • SANTA CLARA, CA 95054 • PHONE (408) 748-3585 • FAX (510) 489-6372
13501 MCCALLEN PASS • AUSTIN, TEXAS 78753 • PHONE (512) 287-2500 • FAX (512) 287-2513

December 9, 2016

ARRIS Group, Inc.
3871 Lakefield Drive Suite 300
Suwanee, GA 30024

Dear Tony Figueiredo,

Enclosed is the EMC Wireless test report for compliance testing of the ARRIS Group, Inc., OG1600 as tested to the requirements of Title 47 of the CFR, Ch. 1 (10-1-06 ed.), Part 15 Subpart C for Intentional Radiators.

Thank you for using the services of MET Laboratories, Inc. If you have any questions regarding these results or if MET can be of further service to you, please feel free to contact me.

Sincerely yours,
MET LABORATORIES, INC.

Jennifer Warnell
Documentation Department

Reference: (\ARRIS Group, Inc.\EMC88858-FCC247 Rev. 2)

Certificates and reports shall not be reproduced except in full, without the written permission of MET Laboratories, Inc.

Electromagnetic Compatibility Criteria Test Report

for the

**ARRIS Group, Inc.
OG1600**

Tested under
the FCC Certification Rules
contained in
15.247 Subpart C for Intentional Radiators

MET Report: EMC88858-FCC247 Rev. 2

December 9, 2016

Prepared For:

**ARRIS Group, Inc.
3871 Lakefield Drive Suite 300
Suwanee, GA 30024**

Prepared By:
MET Laboratories, Inc.
914 W. Patapsco Ave.
Baltimore, MD 21230

**Electromagnetic Compatibility Criteria
Test Report**

for the

**ARRIS Group, Inc.
OG1600**

Tested under
the FCC Certification Rules
contained in
15.247 Subpart C for Intentional Radiators



Surinder Singh, Project Engineer
Electromagnetic Compatibility Lab

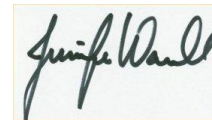

Jennifer Warnell
Documentation Department

Engineering Statement: The measurements shown in this report were made in accordance with the procedures indicated, and the emissions from this equipment were found to be within the limits applicable. I assume full responsibility for the accuracy and completeness of these measurements, and for the qualifications of all persons taking them. It is further stated that upon the basis of the measurements made, the equipment tested is capable of operation in accordance with the requirements of the FCC Rules Part 15.247 under normal use and maintenance.



Asad Bajwa,
Director, Electromagnetic Compatibility Lab

Report Status Sheet

Revision	Report Date	Reason for Revision
Ø	September 14, 2016	Initial Issue.
1	November 16, 2016	Engineer corrections.
2	December 9, 2016	Added antenna gain calculations.

Table of Contents

I.	Executive Summary	1
	A. Purpose of Test	2
	B. Executive Summary	2
II.	Equipment Configuration	3
	A. Overview.....	4
	B. References.....	4
	C. Test Site	5
	D. Description of Test Sample.....	5
	E. Equipment Configuration.....	5
	F. Support Equipment	6
	G. Ports and Cabling Information.....	6
	H. Mode of Operation.....	6
	I. Method of Monitoring EUT Operation	6
	J. Modifications	6
	a) Modifications to EUT.....	6
	b) Modifications to Test Standard.....	6
	K. Disposition of EUT	6
III.	Electromagnetic Compatibility Criteria for Intentional Radiators.....	7
	§ 15.203 Antenna Requirement.....	8
	§ 15.207(a) Conducted Emissions Limits.....	11
	§ 15.247(a)(a) 6 dB and 99% Bandwidth	14
	§ 15.247(b) Peak Power Output	20
	§ 15.247(d) Radiated Spurious Emissions Requirements and Band Edge.....	40
	§ 15.247(d) RF Conducted Spurious Emissions Requirements and Band Edge.....	59
	§ 15.247(e) Peak Power Spectral Density	68
	§ 15.247(i) Maximum Permissible Exposure	88
IV.	Test Equipment	89
V.	Certification & User's Manual Information.....	91
	A. Certification Information	92
	B. Label and User's Manual Information	96

List of Tables

Table 1. Executive Summary of EMC Part 15.247 Compliance Testing	2
Table 2. EUT Summary Table.....	4
Table 3. References	4
Table 4. Equipment Configuration	5
Table 5. Support Equipment.....	6
Table 6. Ports and Cabling Information	6
Table 7. Conducted Limits for Intentional Radiators from FCC Part 15 § 15.207(a)	11
Table 8. Conducted Emissions, 15.207(a), Phase Line, Test Results	12
Table 9. Conducted Emissions, 15.207(a), Neutral Line, Test Results	13
Table 10. 6 dB Occupied Bandwidth, Test Results, 802.11b 20 MHz	15
Table 11. 6 dB Occupied Bandwidth, Test Results, 802.11g 20 MHz	15
Table 12. 6 dB Occupied Bandwidth, Test Results, 802.11n 20 MHz	15
Table 13. 6 dB Occupied Bandwidth, Test Results, 802.11n 40 MHz	15
Table 14. Output Power Requirements from §15.247(b)	20
Table 15. Peak Power Output, Test Results	21
Table 16. Restricted Bands of Operation.....	40
Table 17. Radiated Emissions Limits Calculated from FCC Part 15, § 15.209 (a)	41
Table 18. Peak Power Spectral Density, Test Results	69
Table 19. Test Equipment List	90

List of Plots

Plot 1. Conducted Emissions, 15.207(a), Phase Line	12
Plot 2. Conducted Emissions, 15.207(a), Neutral Line	13
Plot 3. 6 dB Occupied Bandwidth, Low Channel, 802.11b 20 MHz.....	16
Plot 4. 6 dB Occupied Bandwidth, Mid Channel, 802.11b 20 MHz	16
Plot 5. 6 dB Occupied Bandwidth, High Channel, 802.11b 20 MHz	16
Plot 6. 6 dB Occupied Bandwidth, Low Channel, 802.11g 20 MHz.....	17
Plot 7. 6 dB Occupied Bandwidth, Mid Channel, 802.11g 20 MHz	17
Plot 8. 6 dB Occupied Bandwidth, High Channel, 802.11g 20 MHz	17
Plot 9. 6 dB Occupied Bandwidth, Low Channel, 802.11n 20 MHz.....	18
Plot 10. 6 dB Occupied Bandwidth, Mid Channel, 802.11n 20 MHz	18
Plot 11. 6 dB Occupied Bandwidth, High Channel, 802.11n 20 MHz	18
Plot 12. 6 dB Occupied Bandwidth, Low Channel, 802.11n 40 MHz.....	19
Plot 13. 6 dB Occupied Bandwidth, Mid Channel, 802.11n 40 MHz	19
Plot 14. 6 dB Occupied Bandwidth, High Channel, 802.11n 40 MHz	19
Plot 15. Peak Power Output, Low Channel, 802.11b 20 MHz, Port 1	22
Plot 16. Peak Power Output, Mid Channel, 802.11b 20 MHz, Port 1	22
Plot 17. Peak Power Output, High Channel, 802.11b 20 MHz, Port 1	22
Plot 18. Peak Power Output, Low Channel, 802.11g 20 MHz, Port 1	23
Plot 19. Peak Power Output, Mid Channel, 802.11g 20 MHz, Port 1	23
Plot 20. Peak Power Output, High Channel, 802.11g 20 MHz, Port 1	23
Plot 21. Peak Power Output, Low Channel, 802.11n 20 MHz, Port 1	24
Plot 22. Peak Power Output, Mid Channel, 802.11n 20 MHz, Port 1	24
Plot 23. Peak Power Output, High Channel, 802.11n 20 MHz, Port 1	24
Plot 24. Peak Power Output, Low Channel, 802.11n 40 MHz, Port 1	25
Plot 25. Peak Power Output, Mid Channel, 802.11n 40 MHz, Port 1	25
Plot 26. Peak Power Output, High Channel, 802.11n 40 MHz, Port 1	25
Plot 27. Peak Power Output, Low Channel, 802.11b 20 MHz, Port 2	26
Plot 28. Peak Power Output, Mid Channel, 802.11b 20 MHz, Port 2	26

Plot 29. Peak Power Output, High Channel, 802.11b 20 MHz, Port 2	26
Plot 30. Peak Power Output, Low Channel, 802.11g 20 MHz, Port 2	27
Plot 31. Peak Power Output, Mid Channel, 802.11g 20 MHz, Port 2	27
Plot 32. Peak Power Output, High Channel, 802.11g 20 MHz, Port 2	27
Plot 33. Peak Power Output, Low Channel, 802.11n 20 MHz, Port 2	28
Plot 34. Peak Power Output, Mid Channel, 802.11n 20 MHz, Port 2	28
Plot 35. Peak Power Output, High Channel, 802.11n 20 MHz, Port 2	28
Plot 36. Peak Power Output, Low Channel, 802.11n 40 MHz, Port 2	29
Plot 37. Peak Power Output, Mid Channel, 802.11n 40 MHz, Port 2	29
Plot 38. Peak Power Output, High Channel, 802.11n 40 MHz, Port 2	29
Plot 39. Peak Power Output, Low Channel, 802.11b 20 MHz, Port 3	30
Plot 40. Peak Power Output, Mid Channel, 802.11b 20 MHz, Port 3	30
Plot 41. Peak Power Output, High Channel, 802.11b 20 MHz, Port 3	30
Plot 42. Peak Power Output, Low Channel, 802.11g 20 MHz, Port 3	31
Plot 43. Peak Power Output, Mid Channel, 802.11g 20 MHz, Port 3	31
Plot 44. Peak Power Output, High Channel, 802.11g 20 MHz, Port 3	31
Plot 45. Peak Power Output, Low Channel, 802.11n 20 MHz, Port 3	32
Plot 46. Peak Power Output, Mid Channel, 802.11n 20 MHz, Port 3	32
Plot 47. Peak Power Output, High Channel, 802.11n 20 MHz, Port 3	32
Plot 48. Peak Power Output, Low Channel, 802.11n 40 MHz, Port 3	33
Plot 49. Peak Power Output, Mid Channel, 802.11n 40 MHz, Port 3	33
Plot 50. Peak Power Output, High Channel, 802.11n 40 MHz, Port 3	33
Plot 51. Peak Power Output, CDD, Low Channel, 802.11n 20 MHz, Port 1	34
Plot 52. Peak Power Output, CDD, Mid Channel, 802.11n 20 MHz, Port 1	34
Plot 53. Peak Power Output, CDD, High Channel, 802.11n 20 MHz, Port 1	34
Plot 54. Peak Power Output, CDD, Low Channel, 802.11n 40 MHz, Port 1	35
Plot 55. Peak Power Output, CDD, Mid Channel, 802.11n 40 MHz, Port 1	35
Plot 56. Peak Power Output, CDD, High Channel, 802.11n 40 MHz, Port 1	35
Plot 57. Peak Power Output, CDD, Low Channel, 802.11n 20 MHz, Port 2	36
Plot 58. Peak Power Output, CDD, Mid Channel, 802.11n 20 MHz, Port 2	36
Plot 59. Peak Power Output, CDD, High Channel, 802.11n 20 MHz, Port 2	36
Plot 60. Peak Power Output, CDD, Low Channel, 802.11n 40 MHz, Port 2	37
Plot 61. Peak Power Output, CDD, Mid Channel, 802.11n 40 MHz, Port 2	37
Plot 62. Peak Power Output, CDD, High Channel, 802.11n 40 MHz, Port 2	37
Plot 63. Peak Power Output, CDD, Low Channel, 802.11n 20 MHz, Port 3	38
Plot 64. Peak Power Output, CDD, Mid Channel, 802.11n 20 MHz, Port 3	38
Plot 65. Peak Power Output, CDD, High Channel, 802.11n 20 MHz, Port 3	38
Plot 66. Peak Power Output, CDD, Low Channel, 802.11n 40 MHz, Port 3	39
Plot 67. Peak Power Output, CDD, Mid Channel, 802.11n 40 MHz, Port 3	39
Plot 68. Peak Power Output, CDD, High Channel, 802.11n 40 MHz, Port 3	39
Plot 69. Radiated Spurious Emissions, 30 MHz – 1 GHz, Radio Off	42
Plot 70. Radiated Spurious Emissions, 30 MHz – 1 GHz, Radio On	42
Plot 71. Radiated Spurious Emissions, Low Channel, 802.11b 20 MHz, 1 GHz – 7 GHz, Average	43
Plot 72. Radiated Spurious Emissions, Low Channel, 802.11b 20 MHz, 1 GHz – 7 GHz, Peak	43
Plot 73. Radiated Spurious Emissions, Mid Channel, 802.11b 20 MHz, 1 GHz – 7 GHz, Average	43
Plot 74. Radiated Spurious Emissions, Mid Channel, 802.11b 20 MHz, 1 GHz – 7 GHz, Peak	44
Plot 75. Radiated Spurious Emissions, High Channel, 802.11b 20 MHz, 1 GHz – 7 GHz, Average	44
Plot 76. Radiated Spurious Emissions, High Channel, 802.11b 20 MHz, 1 GHz – 7 GHz, Peak	44
Plot 77. Radiated Spurious Emissions, Low Channel, 802.11g 20 MHz, 1 GHz – 7 GHz, Average	45
Plot 78. Radiated Spurious Emissions, Low Channel, 802.11g 20 MHz, 1 GHz – 7 GHz, Peak	45
Plot 79. Radiated Spurious Emissions, Mid Channel, 802.11g 20 MHz, 1 GHz – 7 GHz, Average	45
Plot 80. Radiated Spurious Emissions, Mid Channel, 802.11g 20 MHz, 1 GHz – 7 GHz, Peak	46
Plot 81. Radiated Spurious Emissions, High Channel, 802.11g 20 MHz, 1 GHz – 7 GHz, Average	46

Plot 82. Radiated Spurious Emissions, High Channel, 802.11g 20 MHz, 1 GHz – 7 GHz, Peak	46
Plot 83. Radiated Spurious Emissions, Low Channel, 802.11n 20 MHz, 1 GHz – 7 GHz, Average	47
Plot 84. Radiated Spurious Emissions, Low Channel, 802.11n 20 MHz, 1 GHz – 7 GHz, Peak	47
Plot 85. Radiated Spurious Emissions, Mid Channel, 802.11n 20 MHz, 1 GHz – 7 GHz, Average	47
Plot 86. Radiated Spurious Emissions, Mid Channel, 802.11n 20 MHz, 1 GHz – 7 GHz, Peak	48
Plot 87. Radiated Spurious Emissions, High Channel, 802.11n 20 MHz, 1 GHz – 7 GHz, Average	48
Plot 88. Radiated Spurious Emissions, High Channel, 802.11n 20 MHz, 1 GHz – 7 GHz, Peak	48
Plot 89. Radiated Spurious Emissions, Low Channel, 802.11n 40 MHz, 1 GHz – 7 GHz, Average	49
Plot 90. Radiated Spurious Emissions, Low Channel, 802.11n 40 MHz, 1 GHz – 7 GHz, Peak	49
Plot 91. Radiated Spurious Emissions, Mid Channel, 802.11n 40 MHz, 1 GHz – 7 GHz, Average	49
Plot 92. Radiated Spurious Emissions, Mid Channel, 802.11n 40 MHz, 1 GHz – 7 GHz, Peak	50
Plot 93. Radiated Spurious Emissions, High Channel, 802.11n 40 MHz, 1 GHz – 7 GHz, Average	50
Plot 94. Radiated Spurious Emissions, High Channel, 802.11n 40 MHz, 1 GHz – 7 GHz, Peak	50
Plot 95. Radiated Restricted Band Edge, Low Channel, 802.11b 20 MHz, Average	51
Plot 96. Radiated Restricted Band Edge, Low Channel, 802.11b 20 MHz, Peak	51
Plot 97. Radiated Restricted Band Edge, High Channel, 802.11b 20 MHz, Average	52
Plot 98. Radiated Restricted Band Edge, High Channel, 802.11b 20 MHz, Peak	52
Plot 99. Radiated Restricted Band Edge, Low Channel, 802.11g 20 MHz, Average	53
Plot 100. Radiated Restricted Band Edge, Low Channel, 802.11g 20 MHz, Peak	53
Plot 101. Radiated Restricted Band Edge, High Channel, 802.11g 20 MHz, Average	53
Plot 102. Radiated Restricted Band Edge, High Channel, 802.11g 20 MHz, Peak	54
Plot 103. Radiated Restricted Band Edge, Low Channel, 802.11n 20 MHz, Average	55
Plot 104. Radiated Restricted Band Edge, Low Channel, 802.11n 20 MHz, Peak	55
Plot 105. Radiated Restricted Band Edge, High Channel, 802.11n 20 MHz, Average	55
Plot 106. Radiated Restricted Band Edge, High Channel, 802.11n 20 MHz, Peak	56
Plot 107. Radiated Restricted Band Edge, Low Channel, 802.11n 40 MHz, Average	57
Plot 108. Radiated Restricted Band Edge, Low Channel, 802.11n 40 MHz, Peak	57
Plot 109. Radiated Restricted Band Edge, High Channel, 802.11n 40 MHz, Average	57
Plot 110. Radiated Restricted Band Edge, High Channel, 802.11n 40 MHz, Peak	58
Plot 111. Conducted Spurious Emissions, Low Channel, 802.11b 20 MHz, 1 GHz – 18 GHz	60
Plot 112. Conducted Spurious Emissions, Mid Channel, 802.11b 20 MHz, 1 GHz – 18 GHz	60
Plot 113. Conducted Spurious Emissions, High Channel, 802.11b 20 MHz, 1 GHz – 18 GHz	60
Plot 114. Conducted Spurious Emissions, Low Channel, 802.11g 20 MHz, 1 GHz – 18 GHz	61
Plot 115. Conducted Spurious Emissions, Mid Channel, 802.11g 20 MHz, 1 GHz – 18 GHz	61
Plot 116. Conducted Spurious Emissions, High Channel, 802.11g 20 MHz, 1 GHz – 18 GHz	61
Plot 117. Conducted Spurious Emissions, Low Channel, 802.11n 20 MHz, 1 GHz – 18 GHz	62
Plot 118. Conducted Spurious Emissions, Mid Channel, 802.11n 20 MHz, 1 GHz – 18 GHz	62
Plot 119. Conducted Spurious Emissions, High Channel, 802.11n 20 MHz, 1 GHz – 18 GHz	62
Plot 120. Conducted Spurious Emissions, Low Channel, 802.11n 40 MHz, 1 GHz – 18 GHz	63
Plot 121. Conducted Spurious Emissions, Mid Channel, 802.11n 40 MHz, 1 GHz – 18 GHz	63
Plot 122. Conducted Spurious Emissions, High Channel, 802.11n 40 MHz, 1 GHz – 18 GHz	63
Plot 123. Conducted Band Edge, Low Channel, 802.11b 20 MHz	64
Plot 124. Conducted Band Edge, High Channel, 802.11b 20 MHz	64
Plot 125. Conducted Band Edge, Low Channel, 802.11g 20 MHz	65
Plot 126. Conducted Band Edge, High Channel, 802.11g 20 MHz	65
Plot 127. Conducted Band Edge, Low Channel, 802.11n 20 MHz	66
Plot 128. Conducted Band Edge, High Channel, 802.11n 20 MHz	66
Plot 129. Conducted Band Edge, Low Channel, 802.11n 40 MHz	67
Plot 130. Conducted Band Edge, High Channel, 802.11n 40 MHz	67
Plot 131. Peak Power Spectral Density, Low Channel, 802.11b 20 MHz, Port 1	70
Plot 132. Peak Power Spectral Density, Mid Channel, 802.11b 20 MHz, Port 1	70
Plot 133. Peak Power Spectral Density, High Channel, 802.11b 20 MHz, Port 1	70
Plot 134. Peak Power Spectral Density, Low Channel, 802.11g 20 MHz, Port 1	71

Plot 135. Peak Power Spectral Density, Mid Channel, 802.11g 20 MHz, Port 1	71
Plot 136. Peak Power Spectral Density, High Channel, 802.11g 20 MHz, Port 1	71
Plot 137. Peak Power Spectral Density, Low Channel, 802.11n 20 MHz, Port 1	72
Plot 138. Peak Power Spectral Density, Mid Channel, 802.11n 20 MHz, Port 1	72
Plot 139. Peak Power Spectral Density, High Channel, 802.11n 20 MHz, Port 1	72
Plot 140. Peak Power Spectral Density, Low Channel, 802.11n 40 MHz, Port 1	73
Plot 141. Peak Power Spectral Density, Mid Channel, 802.11n 40 MHz, Port 1	73
Plot 142. Peak Power Spectral Density, High Channel, 802.11n 40 MHz, Port 1	73
Plot 143. Peak Power Spectral Density, Low Channel, 802.11b 20 MHz, Port 2	74
Plot 144. Peak Power Spectral Density, Mid Channel, 802.11b 20 MHz, Port 2	74
Plot 145. Peak Power Spectral Density, High Channel, 802.11b 20 MHz, Port 2	74
Plot 146. Peak Power Spectral Density, Low Channel, 802.11g 20 MHz, Port 2	75
Plot 147. Peak Power Spectral Density, Mid Channel, 802.11g 20 MHz, Port 2	75
Plot 148. Peak Power Spectral Density, High Channel, 802.11g 20 MHz, Port 2	75
Plot 149. Peak Power Spectral Density, Low Channel, 802.11n 20 MHz, Port 2	76
Plot 150. Peak Power Spectral Density, Mid Channel, 802.11n 20 MHz, Port 2	76
Plot 151. Peak Power Spectral Density, High Channel, 802.11n 20 MHz, Port 2	76
Plot 152. Peak Power Spectral Density, Low Channel, 802.11n 40 MHz, Port 2	77
Plot 153. Peak Power Spectral Density, Mid Channel, 802.11n 40 MHz, Port 2	77
Plot 154. Peak Power Spectral Density, High Channel, 802.11n 40 MHz, Port 2	77
Plot 155. Peak Power Spectral Density, Low Channel, 802.11b 20 MHz, Port 3	78
Plot 156. Peak Power Spectral Density, Mid Channel, 802.11b 20 MHz, Port 3	78
Plot 157. Peak Power Spectral Density, High Channel, 802.11b 20 MHz, Port 3	78
Plot 158. Peak Power Spectral Density, Low Channel, 802.11g 20 MHz, Port 3	79
Plot 159. Peak Power Spectral Density, Mid Channel, 802.11g 20 MHz, Port 3	79
Plot 160. Peak Power Spectral Density, High Channel, 802.11g 20 MHz, Port 3	79
Plot 161. Peak Power Spectral Density, Low Channel, 802.11n 20 MHz, Port 3	80
Plot 162. Peak Power Spectral Density, Mid Channel, 802.11n 20 MHz, Port 3	80
Plot 163. Peak Power Spectral Density, High Channel, 802.11n 20 MHz, Port 3	80
Plot 164. Peak Power Spectral Density, Low Channel, 802.11n 40 MHz, Port 3	81
Plot 165. Peak Power Spectral Density, Mid Channel, 802.11n 40 MHz, Port 3	81
Plot 166. Peak Power Spectral Density, High Channel, 802.11n 40 MHz, Port 3	81
Plot 167. Peak Power Spectral Density, CDD, Low Channel, 802.11n 20 MHz, Port 1	82
Plot 168. Peak Power Spectral Density, CDD, Mid Channel, 802.11n 20 MHz, Port 1	82
Plot 169. Peak Power Spectral Density, CDD, High Channel, 802.11n 20 MHz, Port 1	82
Plot 170. Peak Power Spectral Density, CDD, Low Channel, 802.11n 40 MHz, Port 1	83
Plot 171. Peak Power Spectral Density, CDD, Mid Channel, 802.11n 40 MHz, Port 1	83
Plot 172. Peak Power Spectral Density, CDD, High Channel, 802.11n 40 MHz, Port 1	83
Plot 173. Peak Power Spectral Density, CDD, Low Channel, 802.11n 20 MHz, Port 2	84
Plot 174. Peak Power Spectral Density, CDD, Mid Channel, 802.11n 20 MHz, Port 2	84
Plot 175. Peak Power Spectral Density, CDD, High Channel, 802.11n 20 MHz, Port 2	84
Plot 176. Peak Power Spectral Density, CDD, Low Channel, 802.11n 40 MHz, Port 2	85
Plot 177. Peak Power Spectral Density, CDD, Mid Channel, 802.11n 40 MHz, Port 2	85
Plot 178. Peak Power Spectral Density, CDD, High Channel, 802.11n 40 MHz, Port 2	85
Plot 179. Peak Power Spectral Density, CDD, Low Channel, 802.11n 20 MHz, Port 3	86
Plot 180. Peak Power Spectral Density, CDD, Mid Channel, 802.11n 20 MHz, Port 3	86
Plot 181. Peak Power Spectral Density, CDD, High Channel, 802.11n 20 MHz, Port 3	86
Plot 182. Peak Power Spectral Density, CDD, Low Channel, 802.11n 40 MHz, Port 3	87
Plot 183. Peak Power Spectral Density, CDD, Mid Channel, 802.11n 40 MHz, Port 3	87
Plot 184. Peak Power Spectral Density, CDD, High Channel, 802.11n 40 MHz, Port 3	87

List of Figures

Figure 1. Block Diagram of Test Configuration.....	5
Figure 2. Block Diagram, Occupied Bandwidth Test Setup.....	14
Figure 3. Peak Power Output Test Setup.....	21
Figure 4. Block Diagram, Conducted Spurious Emissions Test Setup.....	59
Figure 5. Block Diagram, Peak Power Spectral Density Test Setup	68

List of Terms and Abbreviations

AC	Alternating Current
ACF	Antenna Correction Factor
Cal	Calibration
<i>d</i>	Measurement Distance
dB	Decibels
dB μ A	Decibels above one microamp
dB μ V	Decibels above one microvolt
dB μ A/m	Decibels above one microamp per meter
dB μ V/m	Decibels above one microvolt per meter
DC	Direct Current
E	Electric Field
DSL	Digital Subscriber Line
ESD	Electrostatic Discharge
EUT	Equipment Under Test
<i>f</i>	Frequency
FCC	Federal Communications Commission
GRP	Ground Reference Plane
H	Magnetic Field
HCP	Horizontal Coupling Plane
Hz	Hertz
IEC	International Electrotechnical Commission
kHz	kilohertz
kPa	kilopascal
kV	kilovolt
LISN	Line Impedance Stabilization Network
MHz	Megahertz
μ H	microhenry
μ	microfarad
μ s	microseconds
NEBS	Network Equipment-Building System
PRF	Pulse Repetition Frequency
RF	Radio Frequency
RMS	Root-Mean-Square
TWT	Traveling Wave Tube
V/m	Volts per meter
VCP	Vertical Coupling Plane

I. Executive Summary

A. Purpose of Test

An EMC evaluation was performed to determine compliance of the ARRIS Group, Inc. OG1600, with the requirements of Part 15, §15.247. All references are to the most current version of Title 47 of the Code of Federal Regulations in effect. In accordance with §2.1033, the following data is presented in support of the Certification of the OG1600. ARRIS Group, Inc. should retain a copy of this document which should be kept on file for at least two years after the manufacturing of the OG1600, has been **permanently** discontinued.

B. Executive Summary

The following tests were conducted on a sample of the equipment for the purpose of demonstrating compliance with Part 15, §15.247, in accordance with ARRIS Group, Inc., purchase order number AR1077686. All tests were conducted using measurement procedure ANSI C63.4-2014.

FCC Reference 47 CFR Part 15.247:2005	Description	Compliance
Title 47 of the CFR, Part 15 §15.203	Antenna Requirement	Compliant
Title 47 of the CFR, Part 15 §15.207(a)	Conducted Emission Limits	Compliant
Title 47 of the CFR, Part 15 §15.247(a)(2)	6dB Occupied Bandwidth	Compliant
Title 47 of the CFR, Part 15 §15.247(b)	Peak Power Output	Compliant
Title 47 of the CFR, Part 15 §15.247(d); §15.209; §15.205	Radiated Spurious Emissions Requirements	Compliant
Title 47 of the CFR, Part 15 §15.247(d)	RF Conducted Spurious Emissions Requirements	Compliant
Title 47 of the CFR, Part 15 §15.247(d)	RF Conducted Band Edge	Compliant
Title 47 of the CFR, Part 15; §15.247(e)	Peak Power Spectral Density	Compliant
Title 47 of the CFR, Part 15 §15.247(i)	Maximum Permissible Exposure (MPE)	Compliant

Table 1. Executive Summary of EMC Part 15.247 Compliance Testing

II. Equipment Configuration

A. Overview

MET Laboratories, Inc. was contracted by ARRIS Group, Inc. to perform testing on the OG1600, under ARRIS Group, Inc.'s purchase order number AR1077686.

This document describes the test setups, test methods, required test equipment, and the test limit criteria used to perform compliance testing of the ARRIS Group, Inc., OG1600.

The results obtained relate only to the item(s) tested.

Model(s) Tested:	OG1600	
Model(s) Covered:	OG1600	
EUT Specifications:	Primary Power: 45-90 VAC	
	FCC ID: UIDOG1600CT	
	Type of Modulations:	CCK, OFDM
	Equipment Code:	DTS
	Peak RF Output Power:	28.97 dBm
	EUT Frequency Ranges:	2412-2462 MHz
Analysis:	The results obtained relate only to the item(s) tested.	
Environmental Test Conditions:	Temperature: 15-35° C	
	Relative Humidity: 30-60%	
	Barometric Pressure: 860-1060 mbar	
Evaluated by:	Surinder Singh	
Report Date(s):	December 9, 2016	

Table 2. EUT Summary Table

B. References

CFR 47, Part 15, Subpart C	Federal Communication Commission, Code of Federal Regulations, Title 47, Part 15: General Rules and Regulations, Allocation, Assignment, and Use of Radio Frequencies
ANSI C63.4:2014	Methods and Measurements of Radio-Noise Emissions from Low-Voltage Electrical And Electronic Equipment in the Range of 9 kHz to 40 GHz
ISO/IEC 17025:2005	General Requirements for the Competence of Testing and Calibration Laboratories
ANSI C63.10-2013	American National Standard for Testing Unlicensed Wireless Devices
KDB 558074 v0305	DTS Measurement Guidance
KDB 662911 v01	Multiple Transmitter Output

Table 3. References

C. Test Site

All testing was performed at MET Laboratories, Inc., 914 W. Patapsco Ave., Baltimore, MD 21230. All equipment used in making physical determinations is accurate and bears recent traceability to the National Institute of Standards and Technology.

Radiated Emissions measurements were performed in a 3 meter semi-anechoic chamber (equivalent to an Open Area Test Site). In accordance with §2.948(a)(3), a complete site description is contained at MET Laboratories.

D. Description of Test Sample

The ARRIS Group, Inc. OG1600, Equipment Under Test (EUT), is an outdoor 2.4 GHz & 5 GHz data gateway.

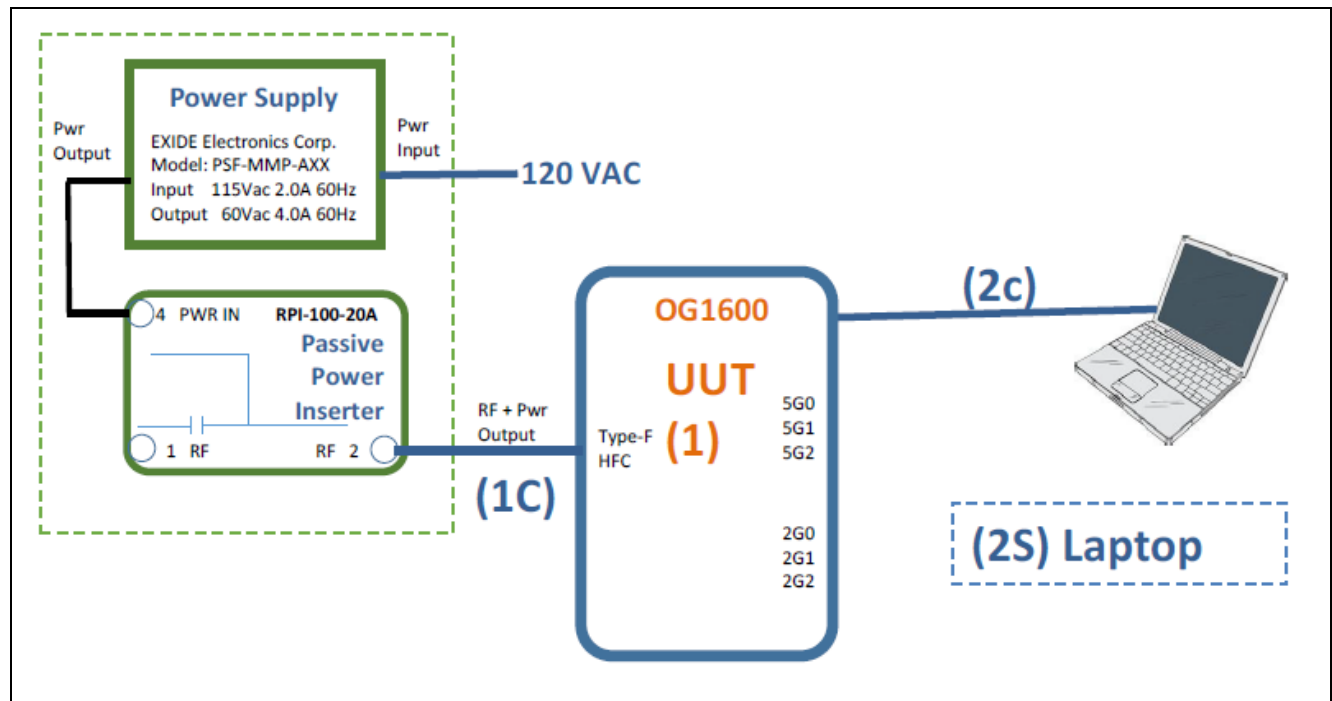

Figure 1. Block Diagram of Test Configuration

E. Equipment Configuration

The EUT was set up as outlined in Figure 1, Block Diagram of Test Setup. All cards, racks, etc., incorporated as part of the EUT is included in the following list.

Ref. ID	Name / Description	Model Number	Part Number	Serial Number	Revision
--	OG1600 Outdoor Access Point	--	--	--	--

Table 4. Equipment Configuration

F. Support Equipment

Support equipment necessary for the operation and testing of the EUT is included in the following list.

Ref. ID	Name / Description	Manufacturer	Model Number
2s	Laptop	Assorted	N/A

Table 5. Support Equipment

G. Ports and Cabling Information

Ref. ID	Port Name on EUT	Cable Description	Qty.	Length (m)	Shielded (Y/N)	Termination Point
2C	Ethernet	5e Modular 8 pin	1	1	No	--
1C	Coax	AC, quasi-square wave	1	2	--	--

Table 6. Ports and Cabling Information

H. Mode of Operation

The provided instructions and software will configure the OG1600 for operation at each required test mode. See configuration.

I. Method of Monitoring EUT Operation

The measured emission value is over the specified FCC/IC limits.

J. Modifications

a) Modifications to EUT

No modifications were made to the EUT.

b) Modifications to Test Standard

No modifications were made to the test standard.

K. Disposition of EUT

The test sample including all support equipment submitted to the Electro-Magnetic Compatibility Lab for testing was returned to ARRIS Group, Inc. upon completion of testing.

III. Electromagnetic Compatibility Criteria for Intentional Radiators

Electromagnetic Compatibility Criteria for Intentional Radiators

§ 15.203 Antenna Requirement

Test Requirement: § 15.203: An intentional radiator shall be designed to ensure that no antenna other than that furnished by the responsible party shall be used with the device. The use of a permanently attached antenna or of an antenna that uses a unique coupling to the intentional radiator shall be considered sufficient to comply with the provisions of this section. The manufacturer may design the unit so that a broken antenna can be replaced by the user, but the use of a standard antenna jack or electrical connector is prohibited.

The structure and application of the EUT were analyzed to determine compliance with Section 15.203 of the Rules. Section 15.203 states that the subject device must meet at least one of the following criteria:

- a.) Antenna must be permanently attached to the unit.
- b.) Antenna must use a unique type of connector to attach to the EUT.
- c.) Unit must be professionally installed. Installer shall be responsible for verifying that the correct antenna is employed with the unit.

Results: The EUT as tested is compliant the criteria of §15.203. EUT has integral antenna that is permanently attached to the unit.

Note: for conducted testing a modified unit with a coaxial pigtail cable in place of the antenna was used.

Test Engineer(s): Surinder Singh

Test Date(s): 05/26/16

Gain-pk : All Space

Unequal Antenna Gains, with equal transmit powers

1) if transmit signals are **Correlated**

KDB 662911 D01 2) d) i), e) ii) (each transmit antenna is driven only by one spatial stream)

Band	Tx Chains	G1 dBi	G2 dBi	G3 dBi	Direction Gain dBi
	3	3.7	3.8	4.1	8.64
UNII-1	3	5.1	5.2	5.7	10.11
UNII-2A	3	5	5.1	5.6	10.01
UNII-2C	3	5.4	5.5	6	10.41
UNII-3	3	5.1	5.2	5.7	10.11

2) if transmit signals are **UnCorrelated**

KDB 662911 D01 2) d) ii)

Band	Tx Chains	G1 dBi	G2 dBi	G3 dBi	Direction Gain dBi
	3	3.7	3.8	4.1	3.87
UNII-1	3	5.1	5.2	5.7	5.34
UNII-2A	3	5	5.1	5.6	5.24
UNII-2C	3	5.4	5.5	6	5.64
UNII-3	3	5.1	5.2	5.7	5.34

Gain-pk Skyward¹, Only

Unequal Antenna Gains, with equal transmit powers

1) if transmit signals are **Correlated**

KDB 662911 D01 2) d) i), e) ii) (each transmit antenna is driven only by one spatial stream)

		G1	G2	G3	Direction Gain
Band	Tx Chains	dBi	dBi	dBi	dBi
UNII-1	3	-7.5	-7.4	-6.9	-2.49

2) if transmit signals are **Uncorrelated**

KDB 662911 D01 2) d) ii)

		G1	G2	G3	Direction Gain
Band	Tx Chains	dBi	dBi	dBi	dBi
UNII-1	3	-7.5	-7.4	-6.9	-7.26

Note(s)

1) Skyward Gain: 15.407(a)(1)(i) : The maximum EIRP +21dBm at any elevation angle above 30 degrees as measured from the horizon.

Electromagnetic Compatibility Criteria for Intentional Radiators

§ 15.207(a) Conducted Emissions Limits

Test Requirement(s): § 15.207 (a): For an intentional radiator that is designed to be connected to the public utility (AC) power line, the radio frequency voltage that is conducted back onto the AC power line on any frequency or frequencies, within the band 150 kHz to 30MHz, shall not exceed the limits in the following table, as measured using a 50 μ H/50 Σ line impedance stabilization network (LISN). Compliance with the provisions of this paragraph shall be based on the measurement of the radio frequency voltage between each power line and ground at the power terminal. The lower limit applies at the boundary between the frequency ranges.

Frequency range (MHz)	§ 15.207(a), Conducted Limit (dB μ V)	
	Quasi-Peak	Average
* 0.15- 0.45	66 - 56	56 - 46
0.45 - 0.5	56	46
0.5 - 30	60	50

Table 7. Conducted Limits for Intentional Radiators from FCC Part 15 § 15.207(a)

Test Procedure: The EUT was placed on a 0.8 m-high wooden table inside a screen room. The EUT was situated such that the back of the EUT was 0.4 m from one wall of the vertical ground plane, and the remaining sides of the EUT were no closer than 0.8 m from any other conductive surface. The EUT was powered from a 50 Ω /50 μ H Line Impedance Stabilization Network (LISN). The EMC receiver scanned the frequency range from 150 kHz to 30 MHz. Conducted Emissions measurements were made in accordance with *ANSI C63.4-2014 "Methods and Measurements of Radio-Noise Emissions from Low-Voltage Electrical and Electronic Equipment in the Range of 9kHz to 40 GHz"*. The measurements were performed over the frequency range of 0.15 MHz to 30 MHz using a 50 Ω /50 μ H LISN as the input transducer to an EMC/field intensity meter. For the purpose of this testing, the transmitter was turned on. Scans were performed with the transmitter on.

Test Results: The EUT was compliant with this requirement.

Test Engineer(s): Surinder Singh

Test Date(s): 06/06/16

15.207(a) Conducted Emissions Test Results

Frequency (MHz)	Uncorrected Meter Reading (dBμV) QP	Cable Loss (dB)	Corrected Measurement (dBμV) QP	Limit (dBμV) QP	Margin (dB) QP	Uncorrected Meter Reading (dBμV) Avg.	Cable Loss (dB)	Corrected Measurement (dBμV) AVG	Limit (dBμV) AVG	Margin (dB) AVG
0.156	58.46	0	58.46	66	-7.54	48.31	0	48.31	56	-7.69
0.456	55.19	0	55.19	56	-0.81	42.21	0	42.21	46	-3.79
1.26	47.16	0	47.16	56	-8.84	34.29	0	34.29	46	-11.71
6.76	38.33	0	38.33	56	-17.67	24.52	0	24.52	46	-21.48
13.46	33.52	0	33.52	56	-22.48	21.37	0	21.37	46	-24.63
24.77	21.34	0	21.34	56	-34.66	16.84	0	16.84	46	-29.16

Table 8. Conducted Emissions, 15.207(a), Phase Line, Test Results

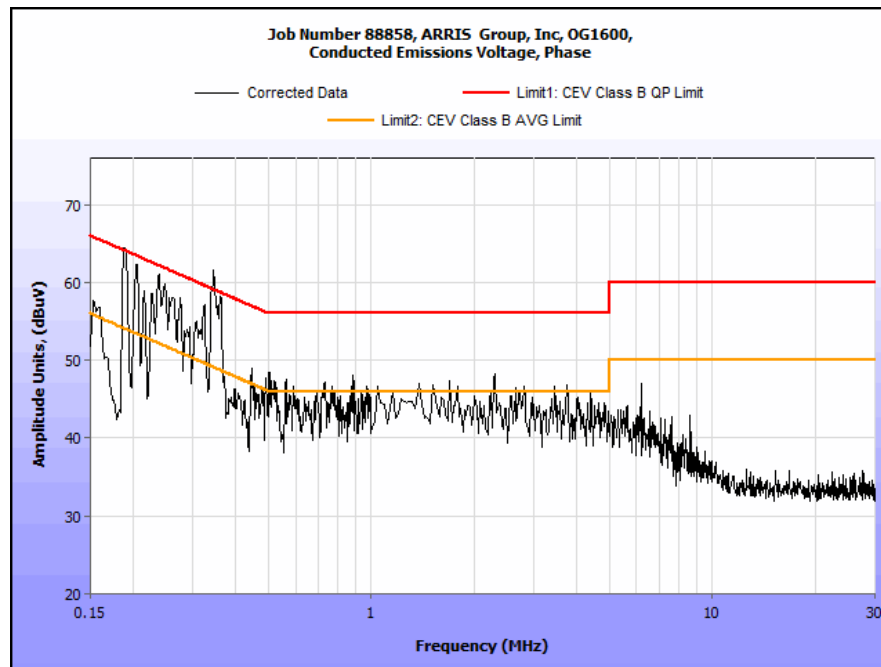

Plot 1. Conducted Emissions, 15.207(a), Phase Line

15.207(a) Conducted Emissions Test Results

Frequency (MHz)	Uncorrected Meter Reading (dB μ V) QP	Cable Loss (dB)	Corrected Measurement (dB μ V) QP	Limit (dB μ V) QP	Margin (dB) QP	Uncorrected Meter Reading (dB μ V) Avg.	Cable Loss (dB)	Corrected Measurement (dB μ V) AVG	Limit (dB μ V) AVG	Margin (dB) AVG
0.234	54.69	0	54.69	66	-11.31	41.28	0	41.28	56	-14.72
0.645	51.23	0	51.23	56	-4.77	40.19	0	40.19	46	-5.81
3.34	44.36	0	44.36	56	-11.64	32.49	0	32.49	46	-13.51
10.26	40.19	0	40.19	56	-15.81	29.84	0	29.84	46	-16.16
19.42	35.61	0	35.61	56	-20.39	24.12	0	24.12	46	-21.88
29.64	23.46	0	23.46	56	-32.54	14.28	0	14.28	46	-31.72

Table 9. Conducted Emissions, 15.207(a), Neutral Line, Test Results

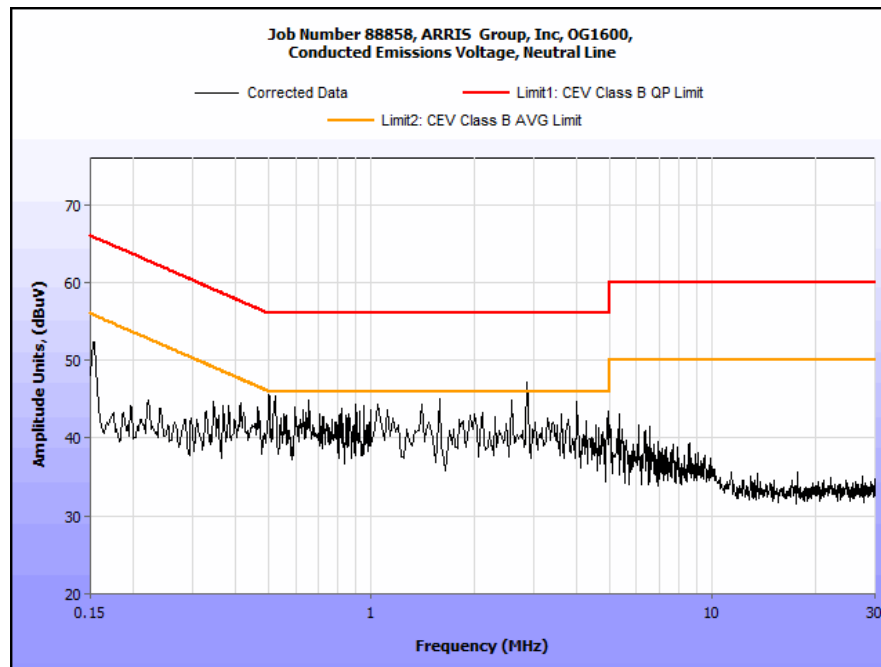

Plot 2. Conducted Emissions, 15.207(a), Neutral Line

Electromagnetic Compatibility Criteria for Intentional Radiators

§ 15.247(a)(2) 6 dB Bandwidth

Test Requirements: § 15.247(a)(2): Operation under the provisions of this section is limited to frequency hopping and digitally modulated intentional radiators that comply with the following provisions:

For systems using digital modulation techniques, the EUT may operate in the 902-928 MHz, 2400-2483.5 MHz and 5725-5850 MHz bands. The minimum 6dB bandwidth shall be at least 500 kHz.

Test Procedure: The transmitter was on and transmitting at the highest output power. The bandwidth of the fundamental frequency was measured with the spectrum analyzer using a RBW approximately 1% of the total emission bandwidth, VBW > RBW. The 6 dB Bandwidth was measured and recorded. The measurements were performed on the low, mid and high channels.

Test Results The EUT was compliant with § 15.247 (a)(2).

The 6 dB Bandwidth was determined from the plots on the following pages.

Test Engineer(s): Surinder Singh

Test Date(s): 05/26/16

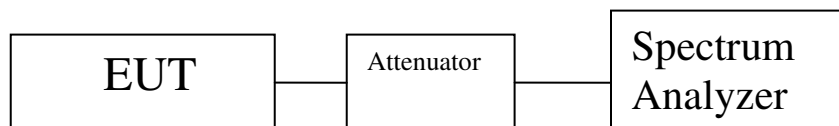

Figure 2. Block Diagram, Occupied Bandwidth Test Setup

Occupied Bandwidth Test Results

Occupied Bandwidth 802.11b 20 MHz		
Carrier Channel	Frequency (MHz)	Measured 6 dB Bandwidth (MHz)
Low	2412	10.103
Mid	2437	10.115
High	2462	10.152

Table 10. 6 dB Occupied Bandwidth, Test Results, 802.11b 20 MHz

Occupied Bandwidth 802.11g 20 MHz		
Carrier Channel	Frequency (MHz)	Measured 6 dB Bandwidth (MHz)
Low	2412	16.403
Mid	2437	16.477
High	2462	16.163

Table 11. 6 dB Occupied Bandwidth, Test Results, 802.11g 20 MHz

Occupied Bandwidth 802.11n 20 MHz		
Carrier Channel	Frequency (MHz)	Measured 6 dB Bandwidth (MHz)
Low	2412	16.990
Mid	2437	15.978
High	2462	17.627

Table 12. 6 dB Occupied Bandwidth, Test Results, 802.11n 20 MHz

Occupied Bandwidth 802.11n 40 MHz		
Carrier Channel	Frequency (MHz)	Measured 6 dB Bandwidth (MHz)
Low	2422	35.828
Mid	2437	36.339
High	2462	31.935

Table 13. 6 dB Occupied Bandwidth, Test Results, 802.11n 40 MHz

6 dB Occupied Bandwidth Test Results, 802.11b 20 MHz

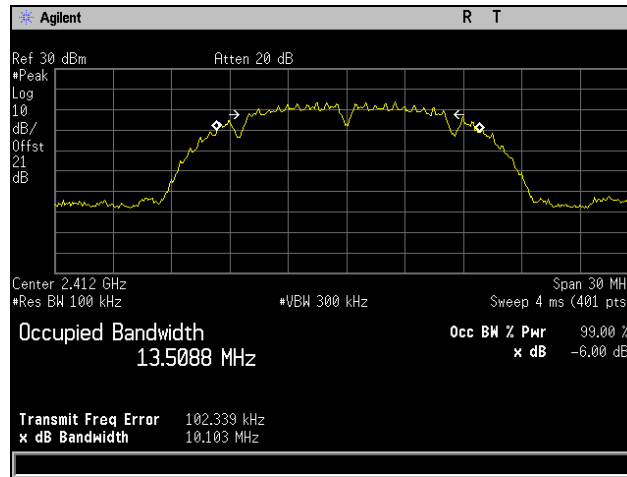

Plot 3. 6 dB Occupied Bandwidth, Low Channel, 802.11b 20 MHz

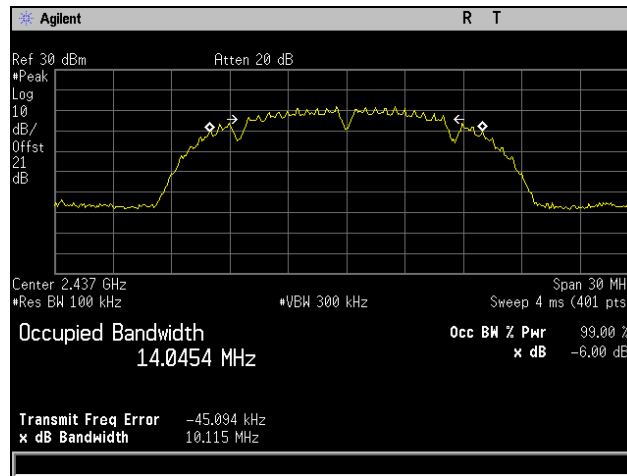

Plot 4. 6 dB Occupied Bandwidth, Mid Channel, 802.11b 20 MHz

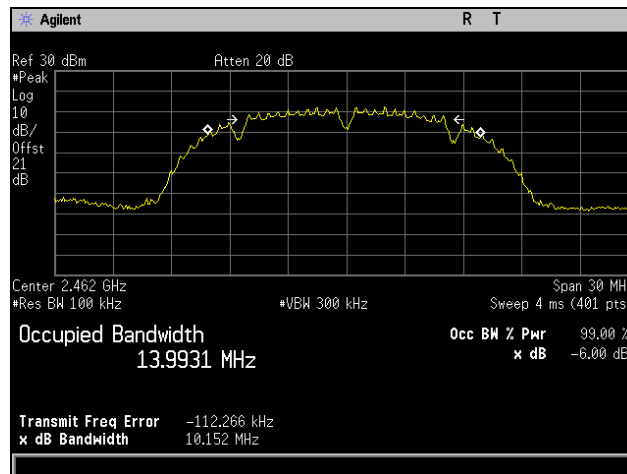

Plot 5. 6 dB Occupied Bandwidth, High Channel, 802.11b 20 MHz

6 dB Occupied Bandwidth Test Results, 802.11b 20 MHz

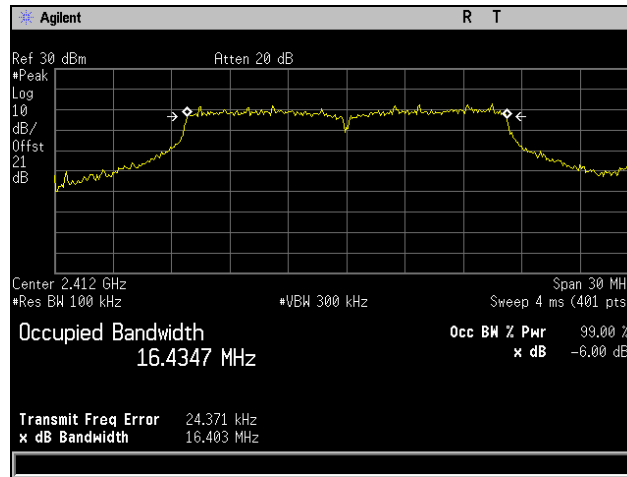

Plot 6. 6 dB Occupied Bandwidth, Low Channel, 802.11g 20 MHz

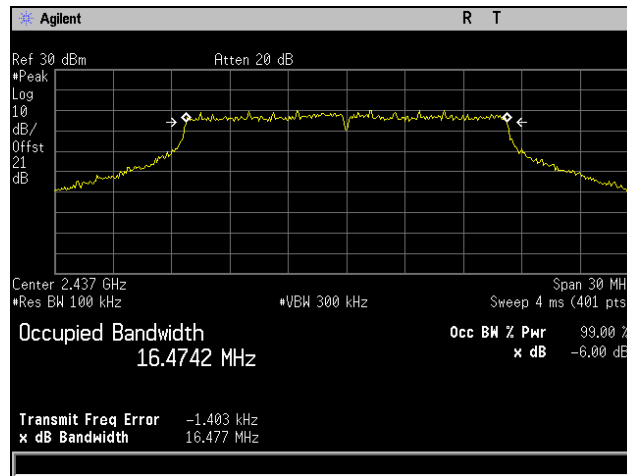

Plot 7. 6 dB Occupied Bandwidth, Mid Channel, 802.11g 20 MHz

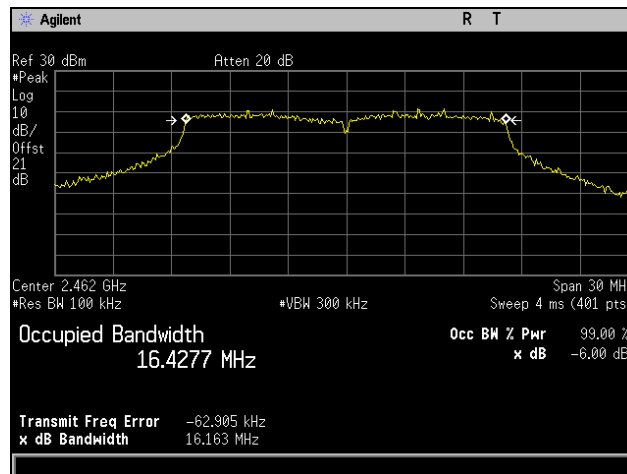

Plot 8. 6 dB Occupied Bandwidth, High Channel, 802.11g 20 MHz

6 dB Occupied Bandwidth Test Results, 802.11n 20 MHz

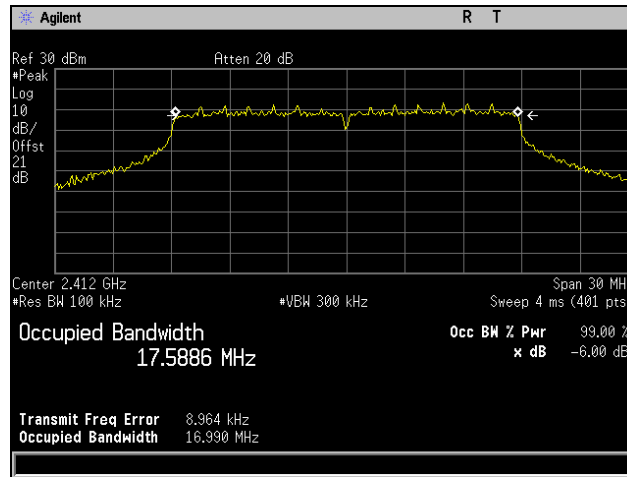

Plot 9. 6 dB Occupied Bandwidth, Low Channel, 802.11n 20 MHz

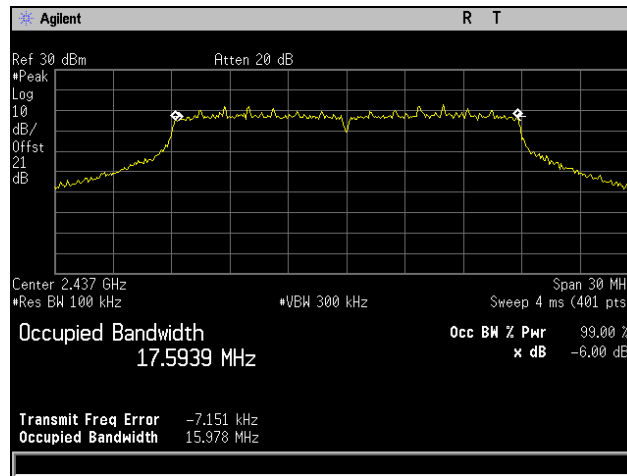

Plot 10. 6 dB Occupied Bandwidth, Mid Channel, 802.11n 20 MHz

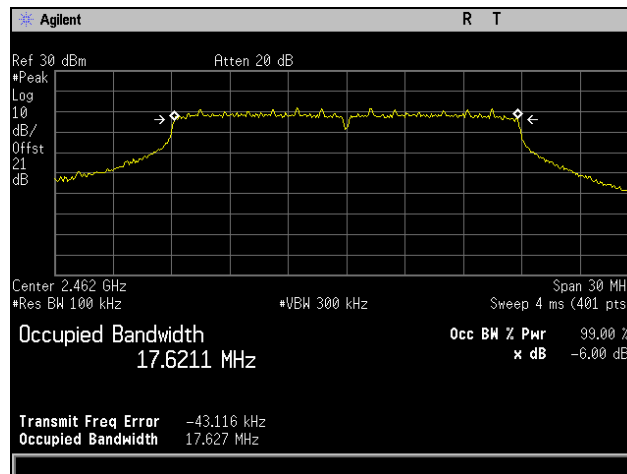

Plot 11. 6 dB Occupied Bandwidth, High Channel, 802.11n 20 MHz

6 dB Occupied Bandwidth Test Results, 802.11n 40 MHz

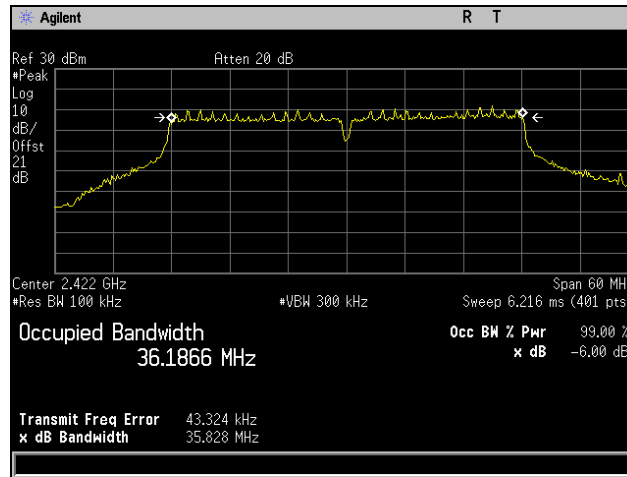

Plot 12. 6 dB Occupied Bandwidth, Low Channel, 802.11n 40 MHz

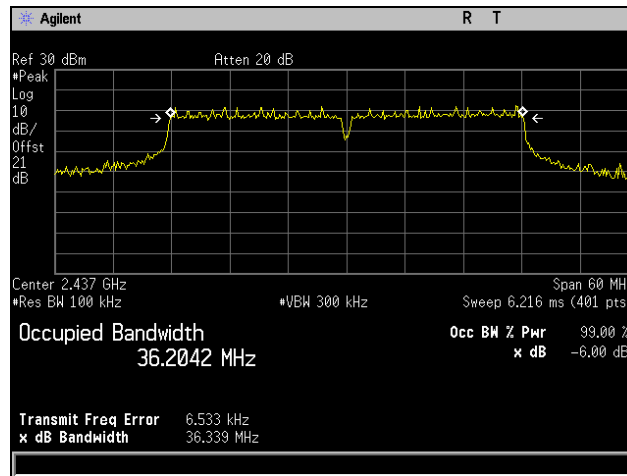

Plot 13. 6 dB Occupied Bandwidth, Mid Channel, 802.11n 40 MHz

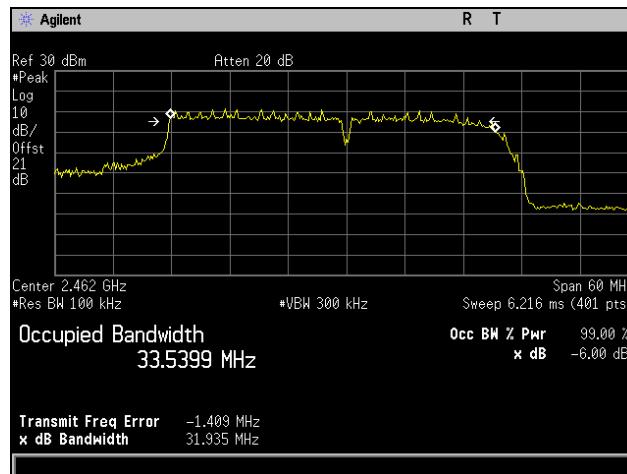

Plot 14. 6 dB Occupied Bandwidth, High Channel, 802.11n 40 MHz

Electromagnetic Compatibility Criteria for Intentional Radiators

§ 15.247(b) Peak Power Output

Test Requirements: §15.247(b): The maximum peak output power of the intentional radiator shall not exceed the following:

Digital Transmission Systems (MHz)	Output Limit (Watts)
902-928	1.000
2400-2483.5	1.000
5725- 5850	1.000

Table 14. Output Power Requirements from §15.247(b)

§15.247(c): if transmitting antennas of directional gain greater than 6 dBi are used the peak output power from the intentional radiator shall be reduced below the stated values in the Table 14, as appropriate, by the amount in dB that the directional gain of the antenna exceeds 6 dBi.

Systems operating in the 2400 – 2483.5 MHz band and using a point to point application may employ transmitting antennas with directional gain greater than 6 dBi provided the maximum peak output power of the intentional radiator is reduced by 1 dB for every 3 dB that the directional gain of the antenna exceeds 6 dBi.

Systems operating in the 5725 – 5850 MHz band that are used exclusively for fixed, point-to-point operations may employ transmitting antennas with directional gain greater than 6 dBi without any corresponding reduction in transmitter peak output power.

Fixed, point-to-point operation excludes the use of point-to-multipoint systems, Omni-directional applications, and multiple co-located intentional radiators transmitting the same information. The operator of the spread spectrum intentional radiator or, if the equipment is professionally installed, the installer is responsible for ensuring that the system is used exclusively for fixed, point-to-point operations. The instruction manual furnished with the intentional radiator shall contain language in the installation instructions informing the operator and the installer of this responsibility.

Test Procedure: The transmitter was connected to a calibrated spectrum analyzer. The EUT was measured at the low, mid and high channels of each band at the maximum power level.

The antenna gain was calculated based on whether the data was correlated or not per KDB 662911. For b and g mode the data is correlated and thus the gain is equal to the array gain of all three antennas. For n mode the data is completely uncorrelated and thus the gain is the single antenna gain.

The methods of KDB558074 Method 9.2.2.2 were used.

Test Results: The EUT was compliant with the Peak Power Output limits of §15.247(b).

Test Engineer(s): Surinder Singh

Test Date(s): 05/27/16

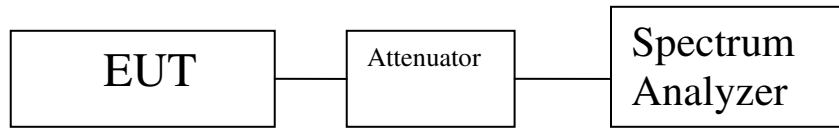
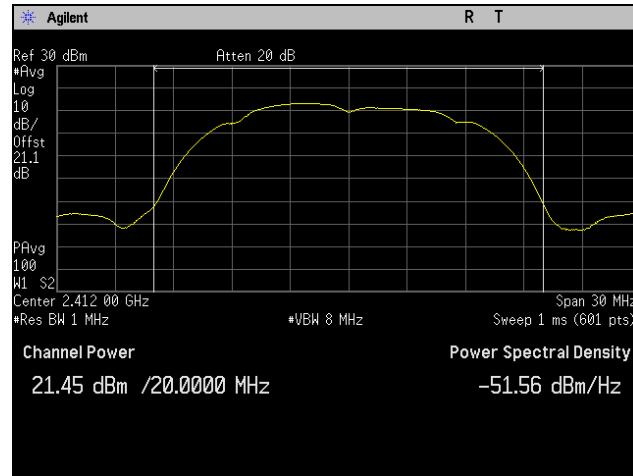

Figure 3. Peak Power Output Test Setup

Center Frequency	Bandwidth	Mode	Transmission Scheme	Port 1 Data (dBm)	Port 2 Data (dBm)	Port 3 Data (dBm)	Sum of Three Port (dBm)	Limit (dBm)	Antenna Gain (dBi)	Final limit (dBm)	Margin dB (db)
Ch 2412M	BW 20M	b mode	CDD	21.45	21.3	23.24	26.87	30	8.64	27.36	-0.49
Ch 2412M	BW 20M	g mode	CDD	22.18	21.89	22.49	26.97	30	8.64	27.36	-0.39
Ch 2412M	BW 20M	n mode	CDD	22.72	21.26	22.8	27.09	30	8.64	27.36	-0.27
Ch 2412M	BW 20M	n mode	SDM	22.08	21.63	22.64	26.91	30	3.88	30	-3.09
Ch 2437M	BW 20M	b mode	CDD	21.54	21.18	21.92	26.33	30	8.64	27.36	-1.03
Ch 2437M	BW 20M	g mode	CDD	21.83	21.86	21.48	26.5	30	8.64	27.36	-0.86
Ch 2437M	BW 20M	n mode	CDD	22.87	21.54	22.05	26.96	30	8.64	27.36	-0.4
Ch 2437M	BW 20M	n mode	SDM	24.93	23.71	23.84	28.97	30	3.88	30	-1.03
Ch 2462M	BW 20M	b mode	CDD	21.73	21.63	22.05	26.58	30	8.64	27.36	-0.78
Ch 2462M	BW 20M	g mode	CDD	22.16	21.75	22.08	26.78	30	8.64	27.36	-0.58
Ch 2462M	BW 20M	n mode	CDD	22.23	21.91	22.2	26.89	30	8.64	27.36	-0.47
Ch 2462M	BW 20M	n mode	SDM	24.07	23.8	24.34	28.85	30	3.88	30	-1.15
Ch 2422M	BW 40M	n mode	CDD	20.11	20.01	22.04	25.6	30	8.64	27.36	-1.76
Ch 2422M	BW 40M	n mode	SDM	20.77	20.15	21.95	25.8	30	3.88	30	-4.2
Ch 2437M	BW 40M	n mode	CDD	21.85	22.3	22.86	27.13	30	8.64	27.36	-0.23
Ch 2437M	BW 40M	n mode	SDM	23.95	22.59	23.82	28.27	30	3.88	30	-1.73
Ch 2452M	BW 40M	n mode	CDD	21.62	21.45	22.09	26.5	30	8.64	27.36	-0.86
Ch 2452M	BW 40M	n mode	SDM	24.88	23.22	24.32	28.97	30	3.88	30	-1.03

Table 15. Peak Power Output, Test Results

Peak Power Output Test Results, 802.11b 20 MHz, Port 1



Plot 15. Peak Power Output, Low Channel, 802.11b 20 MHz, Port 1

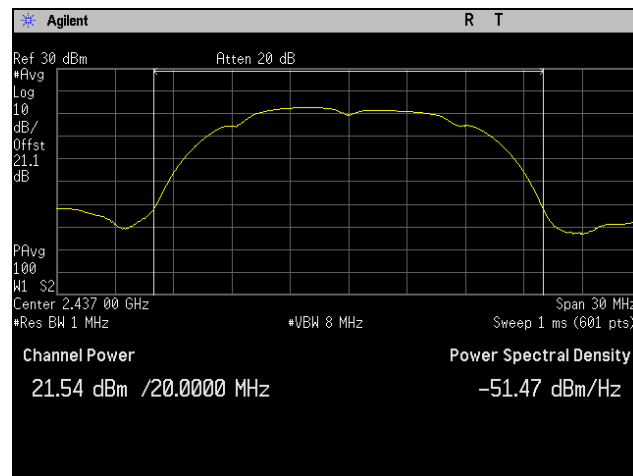

Plot 16. Peak Power Output, Mid Channel, 802.11b 20 MHz, Port 1

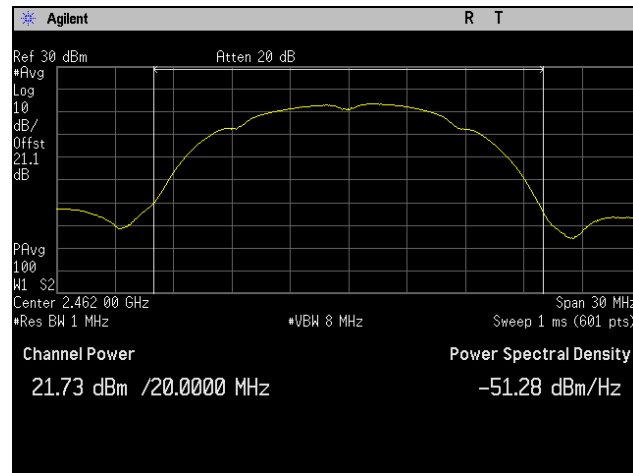

Plot 17. Peak Power Output, High Channel, 802.11b 20 MHz, Port 1

Peak Power Output Test Results, 802.11g 20 MHz, Port 1

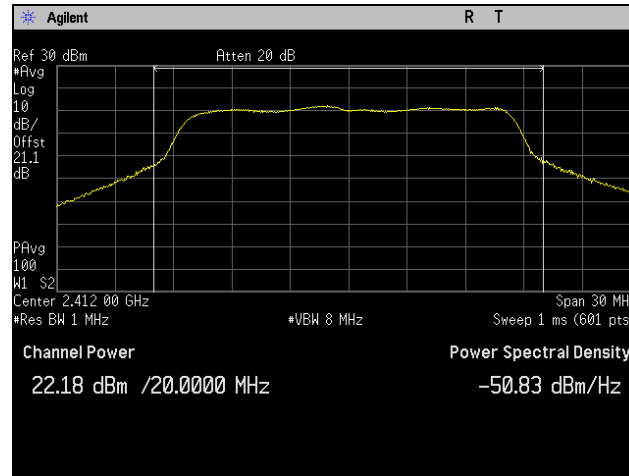

Plot 18. Peak Power Output, Low Channel, 802.11g 20 MHz, Port 1

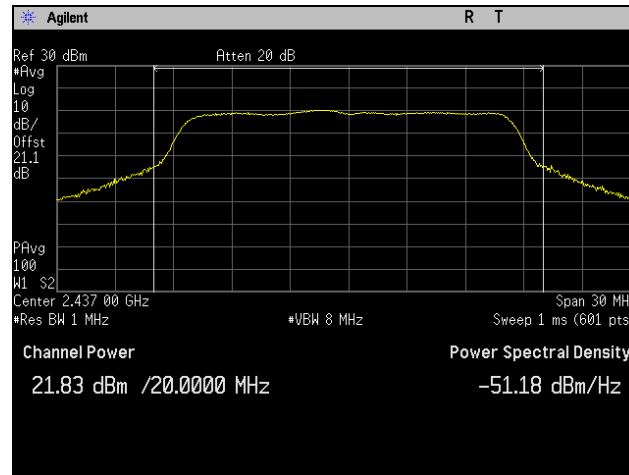

Plot 19. Peak Power Output, Mid Channel, 802.11g 20 MHz, Port 1

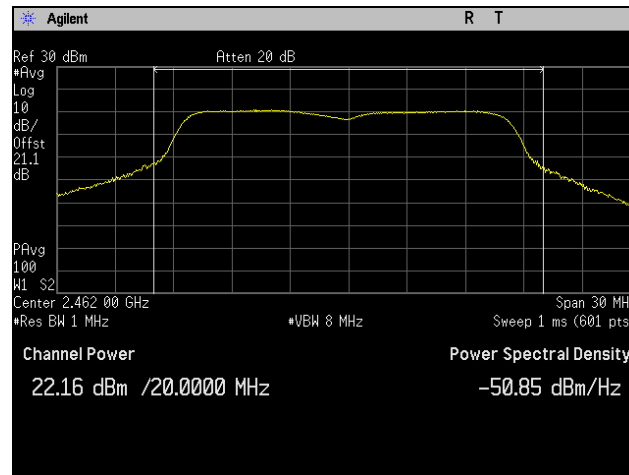

Plot 20. Peak Power Output, High Channel, 802.11g 20 MHz, Port 1

Peak Power Output Test Results, 802.11n 20 MHz, Port 1

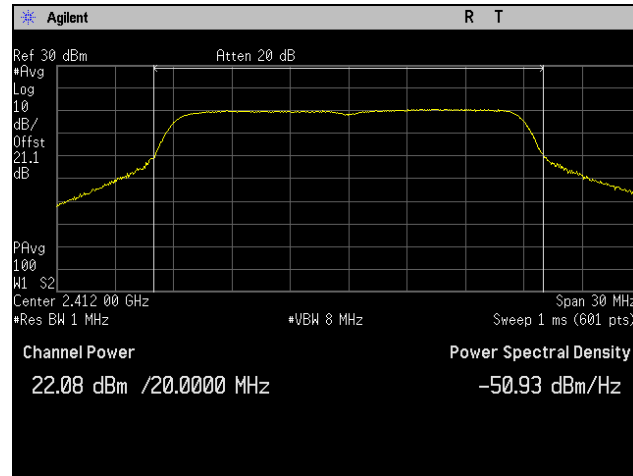

Plot 21. Peak Power Output, Low Channel, 802.11n 20 MHz, Port 1

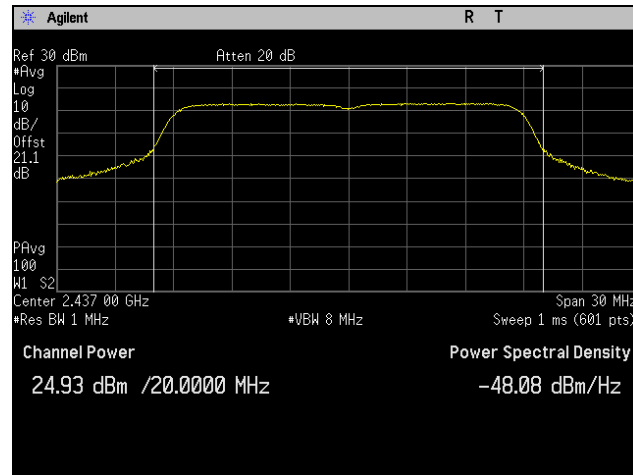

Plot 22. Peak Power Output, Mid Channel, 802.11n 20 MHz, Port 1

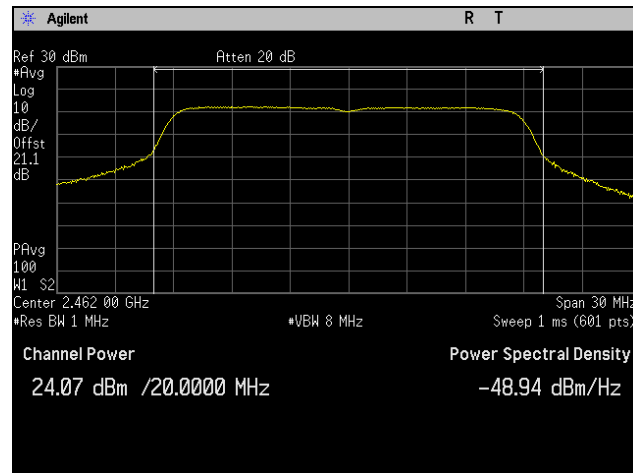

Plot 23. Peak Power Output, High Channel, 802.11n 20 MHz, Port 1

Peak Power Output Test Results, 802.11n 40 MHz, Port 1

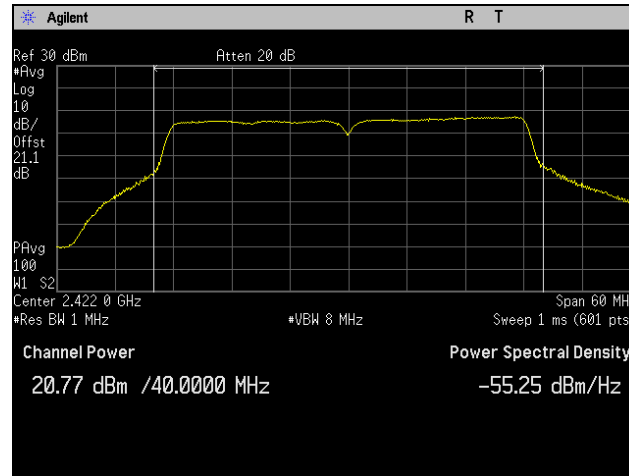

Plot 24. Peak Power Output, Low Channel, 802.11n 40 MHz, Port 1

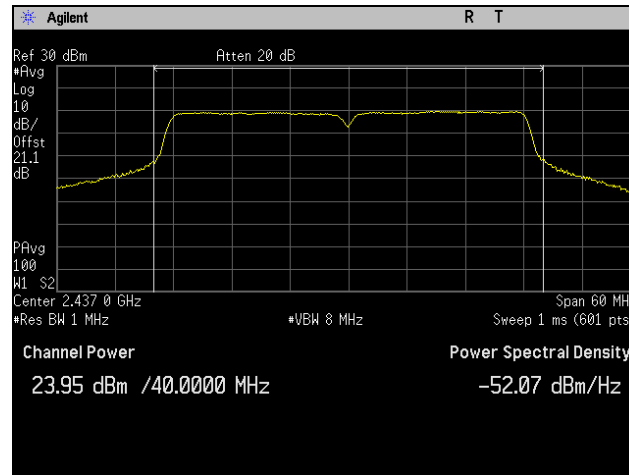

Plot 25. Peak Power Output, Mid Channel, 802.11n 40 MHz, Port 1

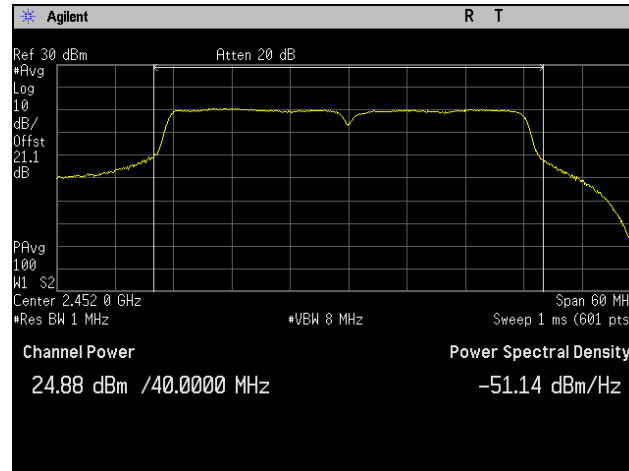

Plot 26. Peak Power Output, High Channel, 802.11n 40 MHz, Port 1

Peak Power Output Test Results, 802.11b 20 MHz, Port 2

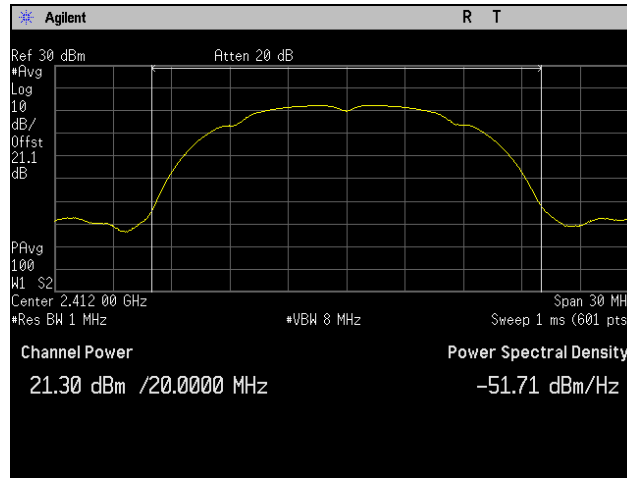

Plot 27. Peak Power Output, Low Channel, 802.11b 20 MHz, Port 2

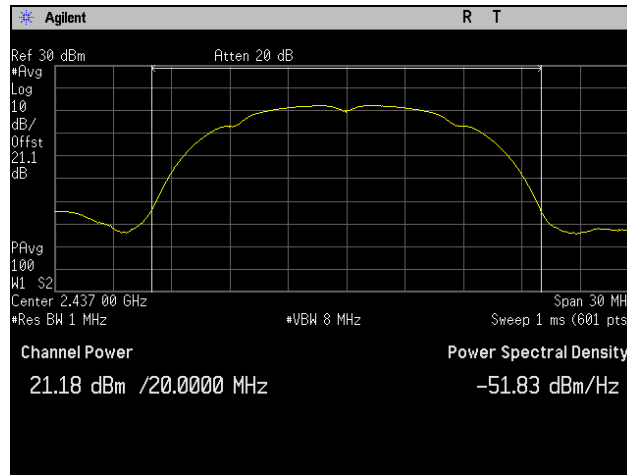

Plot 28. Peak Power Output, Mid Channel, 802.11b 20 MHz, Port 2

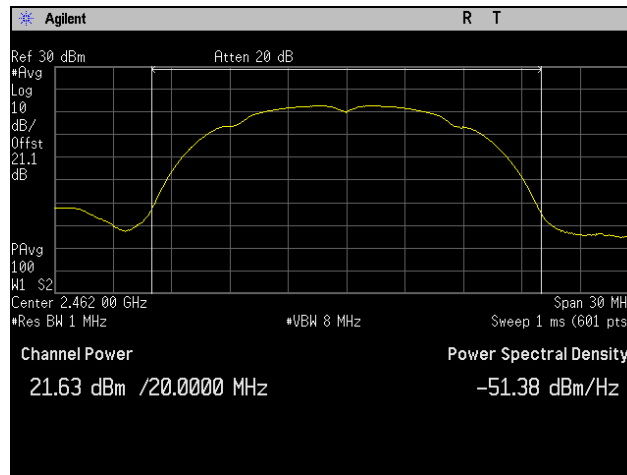

Plot 29. Peak Power Output, High Channel, 802.11b 20 MHz, Port 2

Peak Power Output Test Results, 802.11g 20 MHz, Port 2

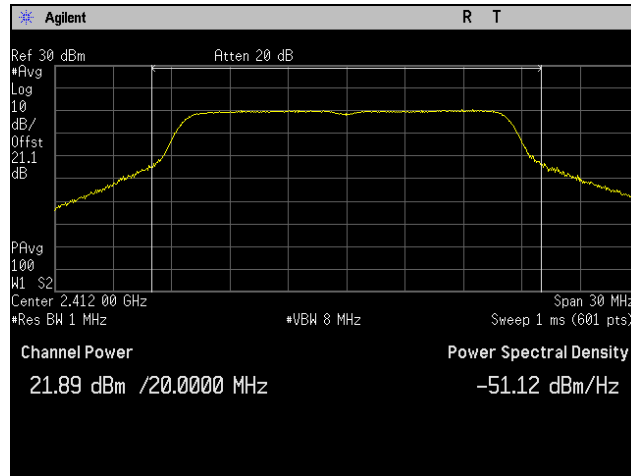

Plot 30. Peak Power Output, Low Channel, 802.11g 20 MHz, Port 2

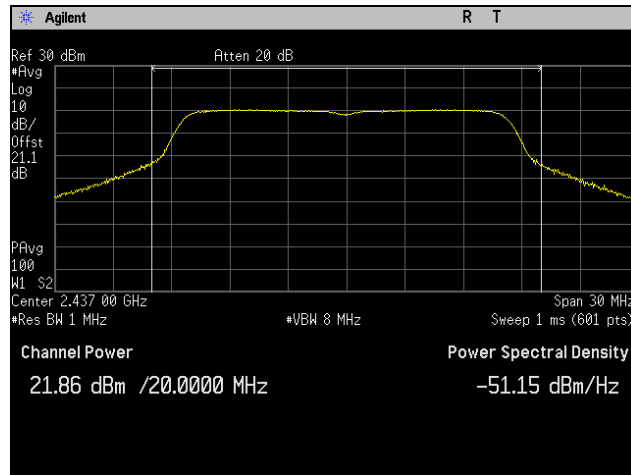

Plot 31. Peak Power Output, Mid Channel, 802.11g 20 MHz, Port 2

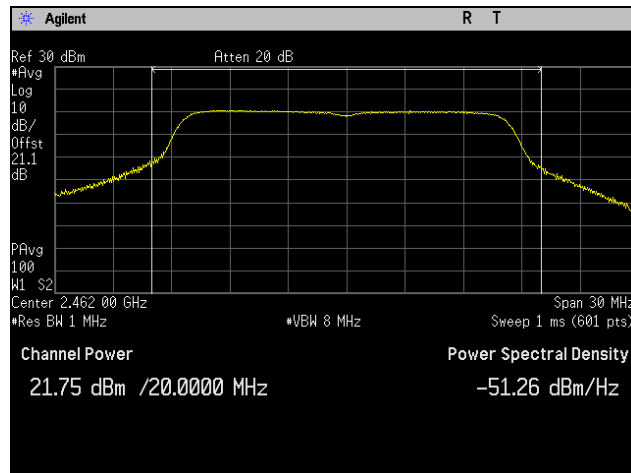

Plot 32. Peak Power Output, High Channel, 802.11g 20 MHz, Port 2

Peak Power Output Test Results, 802.11n 20 MHz, Port 2

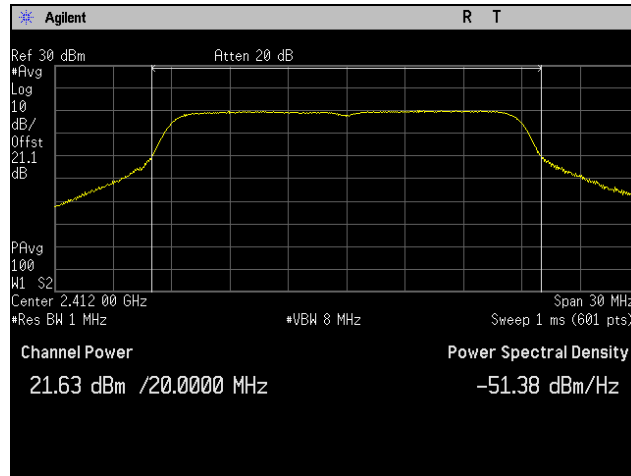

Plot 33. Peak Power Output, Low Channel, 802.11n 20 MHz, Port 2

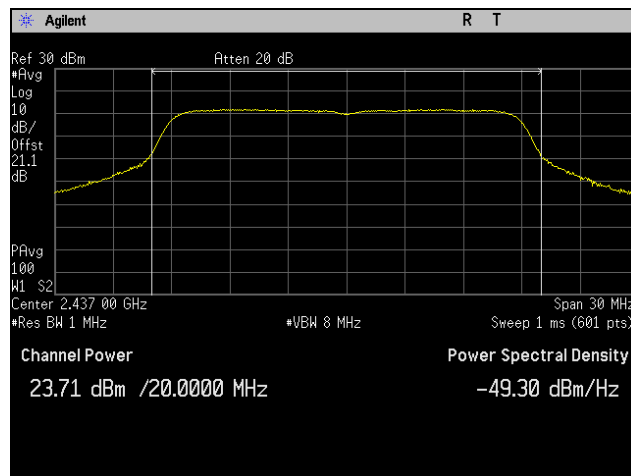

Plot 34. Peak Power Output, Mid Channel, 802.11n 20 MHz, Port 2

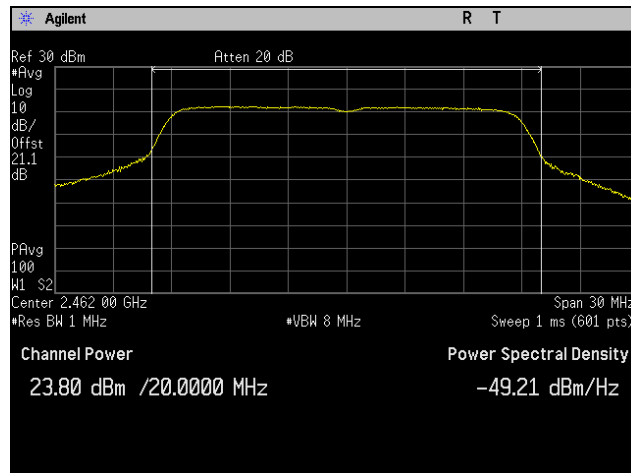

Plot 35. Peak Power Output, High Channel, 802.11n 20 MHz, Port 2

Peak Power Output Test Results, 802.11n 40 MHz, Port 2

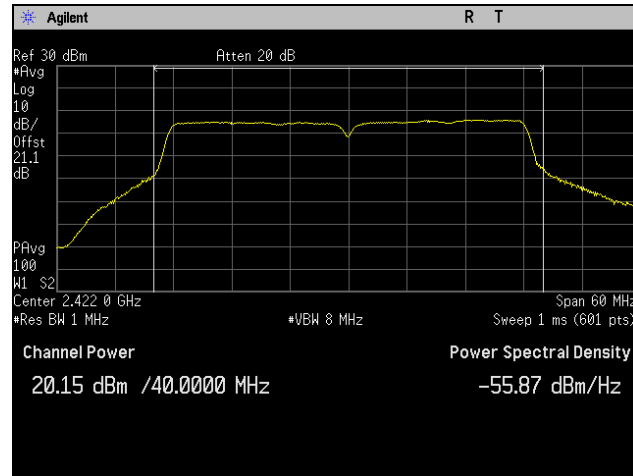

Plot 36. Peak Power Output, Low Channel, 802.11n 40 MHz, Port 2

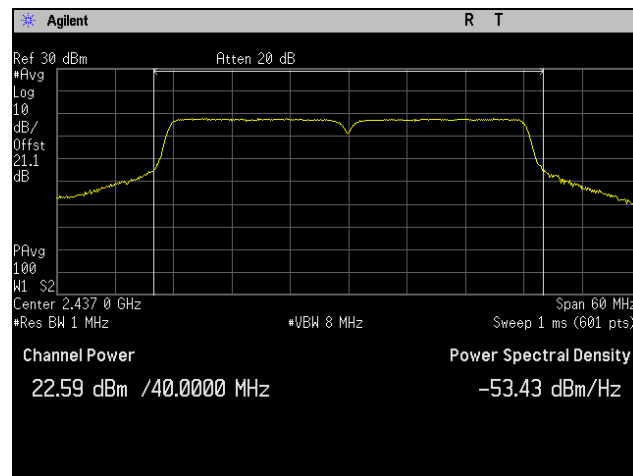

Plot 37. Peak Power Output, Mid Channel, 802.11n 40 MHz, Port 2

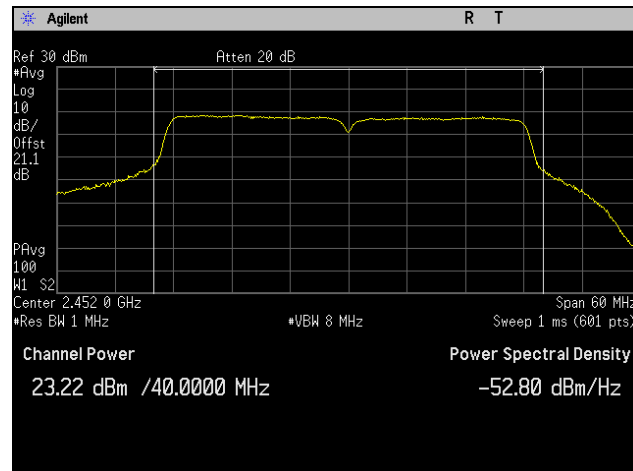

Plot 38. Peak Power Output, High Channel, 802.11n 40 MHz, Port 2

Peak Power Output Test Results, 802.11b 20 MHz, Port 3

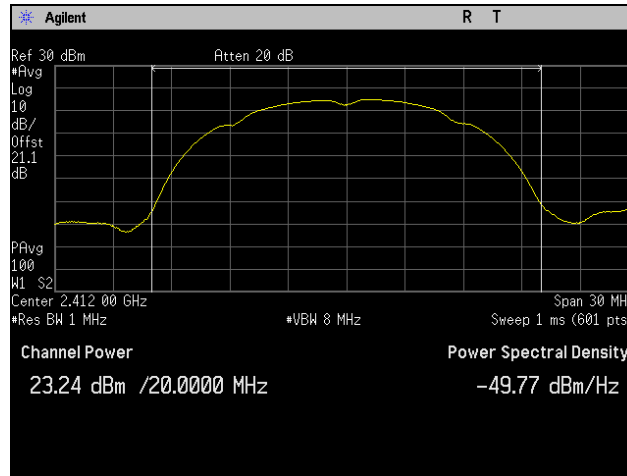

Plot 39. Peak Power Output, Low Channel, 802.11b 20 MHz, Port 3

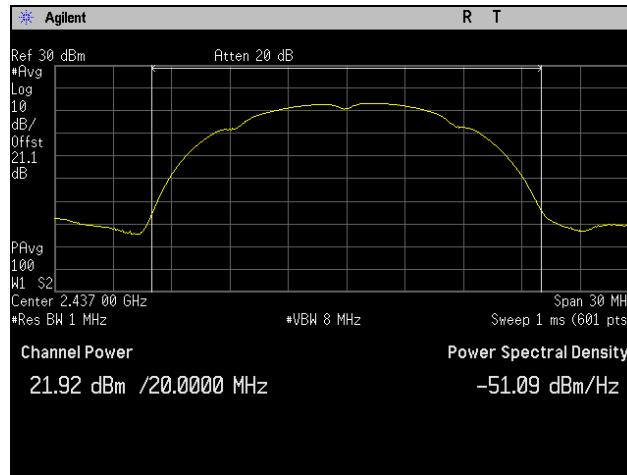

Plot 40. Peak Power Output, Mid Channel, 802.11b 20 MHz, Port 3

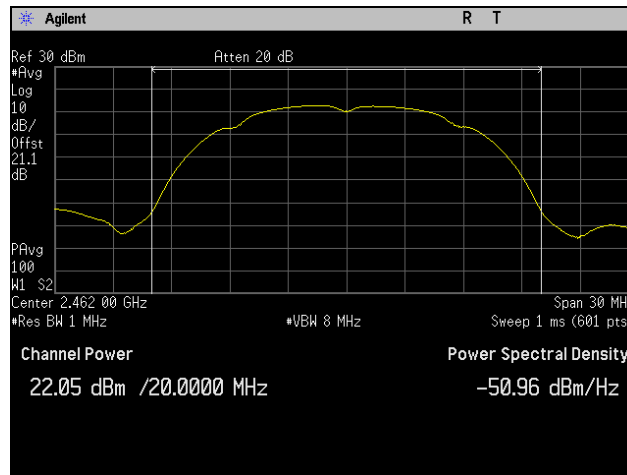

Plot 41. Peak Power Output, High Channel, 802.11b 20 MHz, Port 3

Peak Power Output Test Results, 802.11g 20 MHz, Port 3

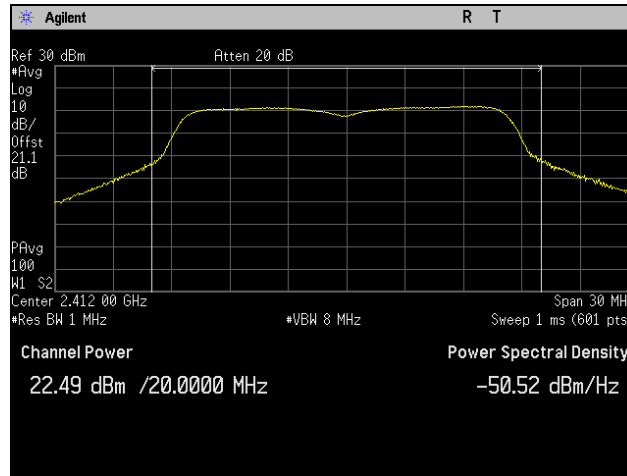

Plot 42. Peak Power Output, Low Channel, 802.11g 20 MHz, Port 3

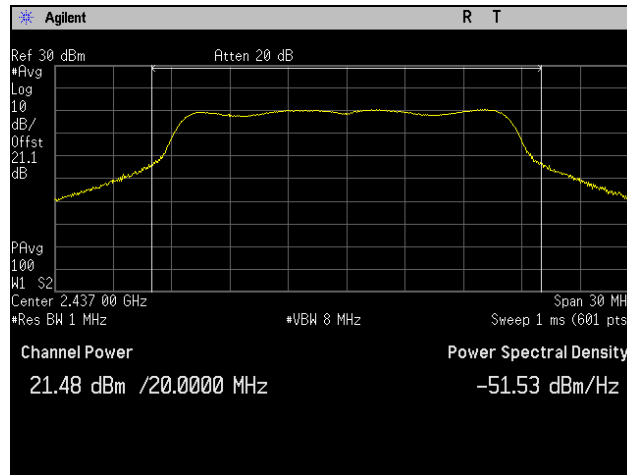

Plot 43. Peak Power Output, Mid Channel, 802.11g 20 MHz, Port 3

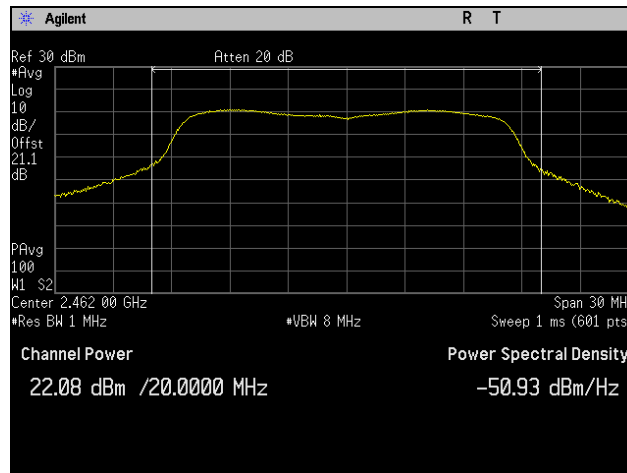

Plot 44. Peak Power Output, High Channel, 802.11g 20 MHz, Port 3

Peak Power Output Test Results, 802.11n 20 MHz, Port 3

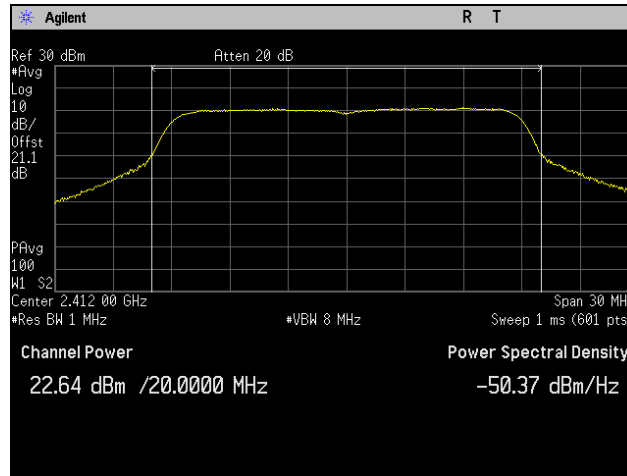

Plot 45. Peak Power Output, Low Channel, 802.11n 20 MHz, Port 3

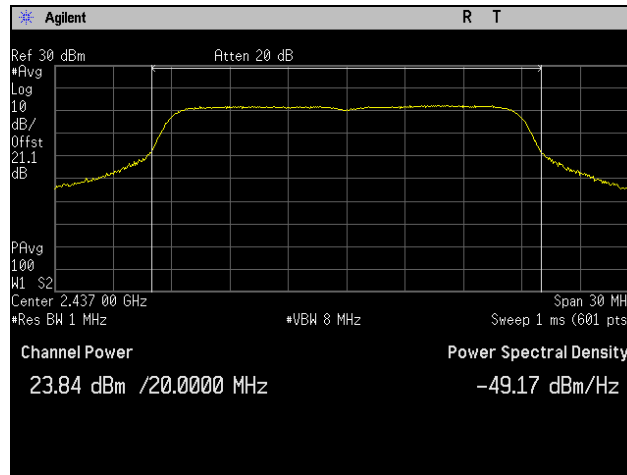

Plot 46. Peak Power Output, Mid Channel, 802.11n 20 MHz, Port 3

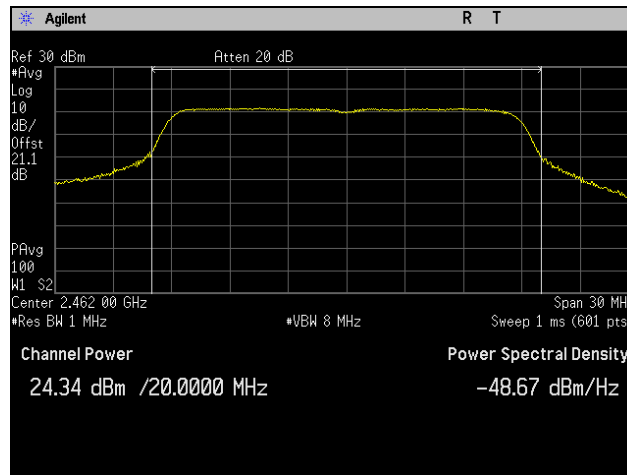

Plot 47. Peak Power Output, High Channel, 802.11n 20 MHz, Port 3

Peak Power Output Test Results, 802.11n 40 MHz, Port 3

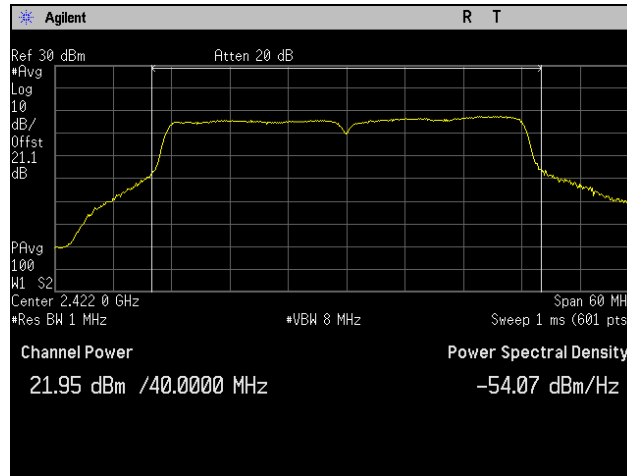

Plot 48. Peak Power Output, Low Channel, 802.11n 40 MHz, Port 3

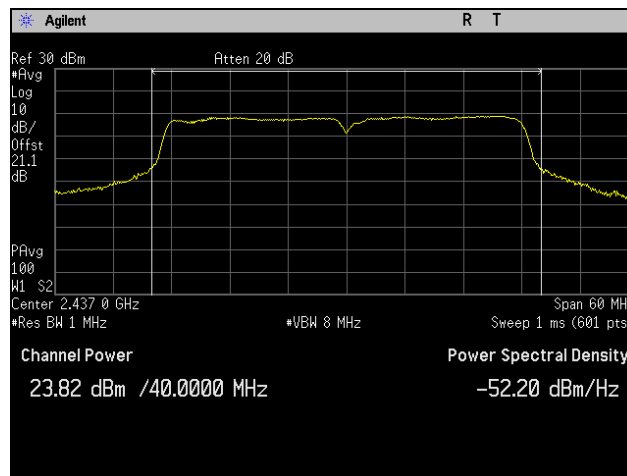

Plot 49. Peak Power Output, Mid Channel, 802.11n 40 MHz, Port 3

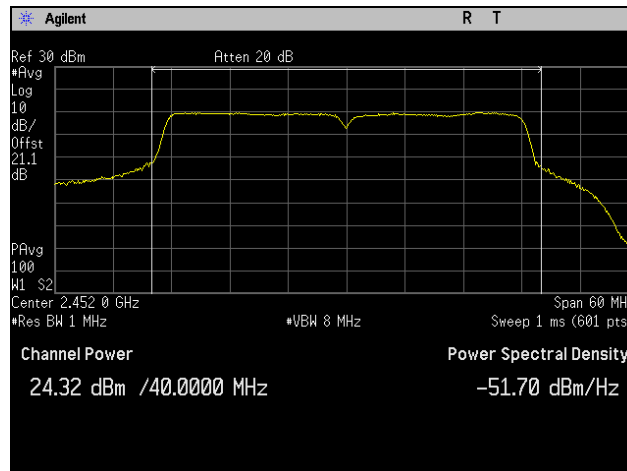

Plot 50. Peak Power Output, High Channel, 802.11n 40 MHz, Port 3

Peak Power Output, CDD, Test Results, 802.11n 20 MHz, Port 1

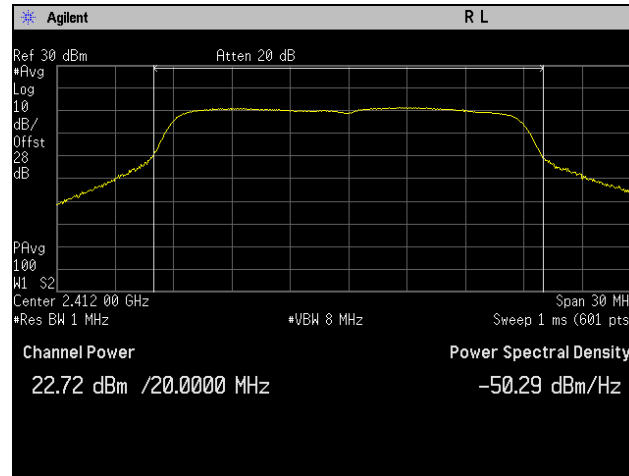

Plot 51. Peak Power Output, CDD, Low Channel, 802.11n 20 MHz, Port 1

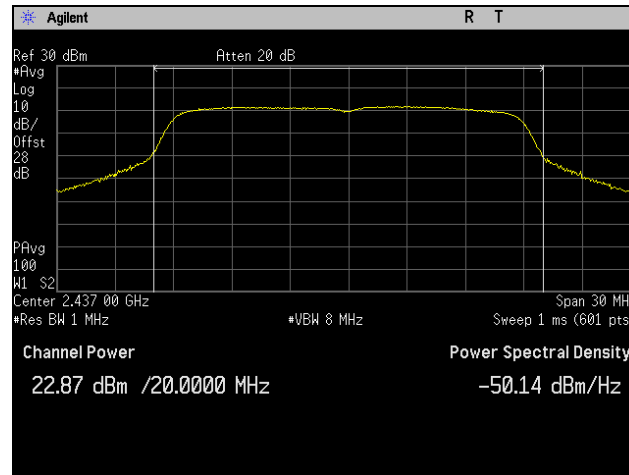

Plot 52. Peak Power Output, CDD, Mid Channel, 802.11n 20 MHz, Port 1

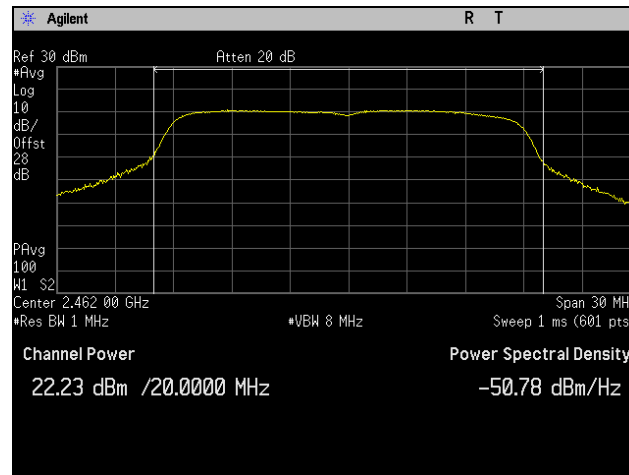

Plot 53. Peak Power Output, CDD, High Channel, 802.11n 20 MHz, Port 1

Peak Power Output, CDD, Test Results, 802.11n 40 MHz, Port 1

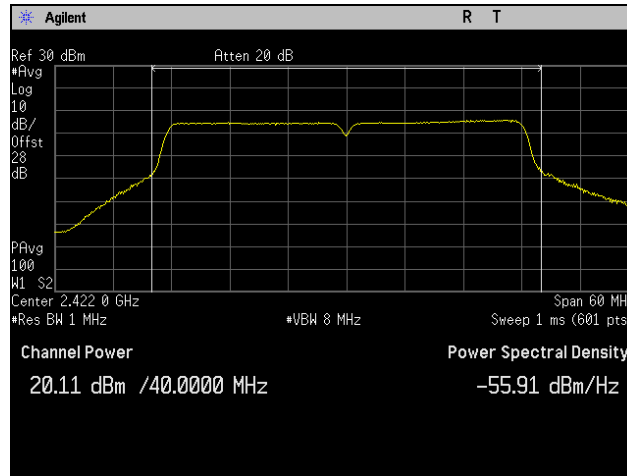

Plot 54. Peak Power Output, CDD, Low Channel, 802.11n 40 MHz, Port 1

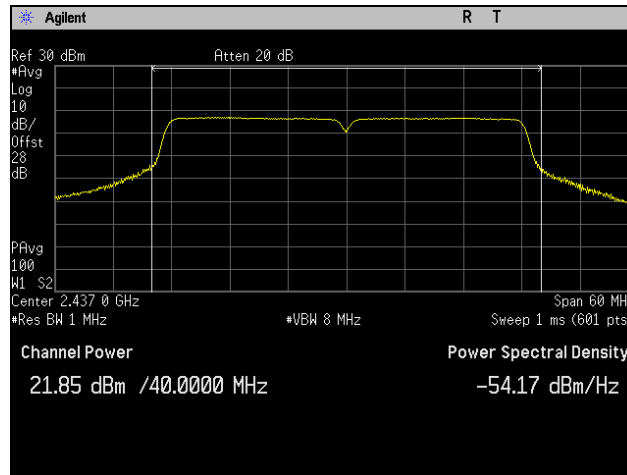

Plot 55. Peak Power Output, CDD, Mid Channel, 802.11n 40 MHz, Port 1

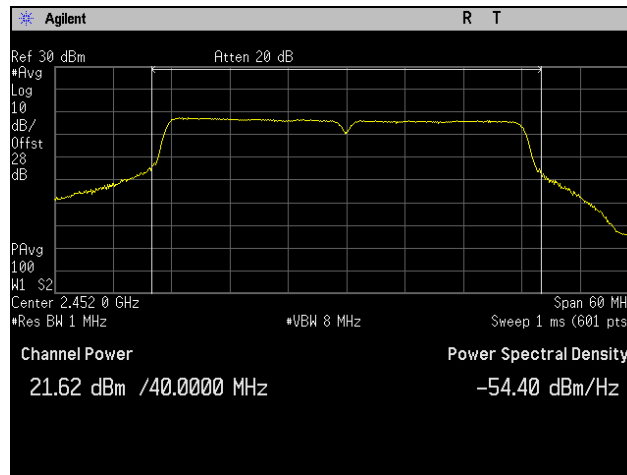

Plot 56. Peak Power Output, CDD, High Channel, 802.11n 40 MHz, Port 1

Peak Power Output, CDD, Test Results, 802.11n 20 MHz, Port 2

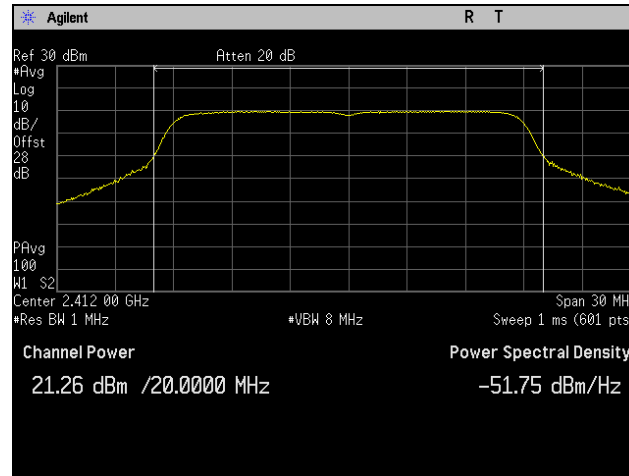

Plot 57. Peak Power Output, CDD, Low Channel, 802.11n 20 MHz, Port 2

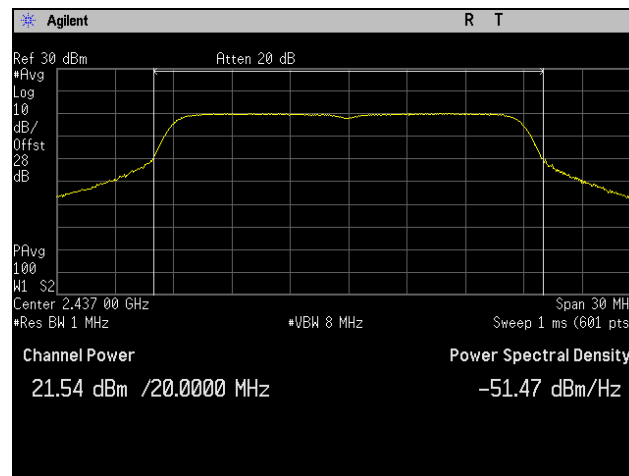

Plot 58. Peak Power Output, CDD, Mid Channel, 802.11n 20 MHz, Port 2

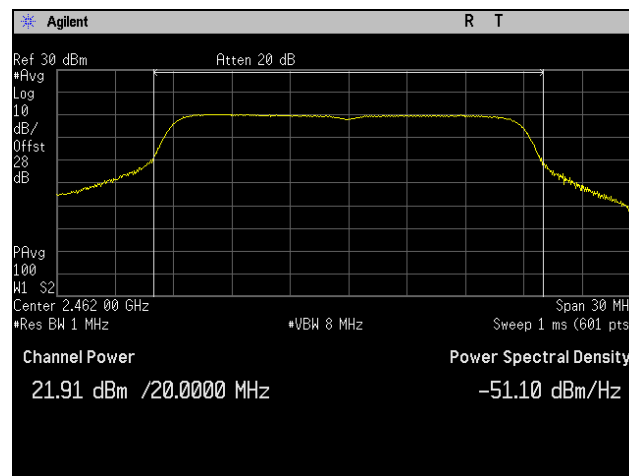

Plot 59. Peak Power Output, CDD, High Channel, 802.11n 20 MHz, Port 2

Peak Power Output, CDD, Test Results, 802.11n 40 MHz, Port 2

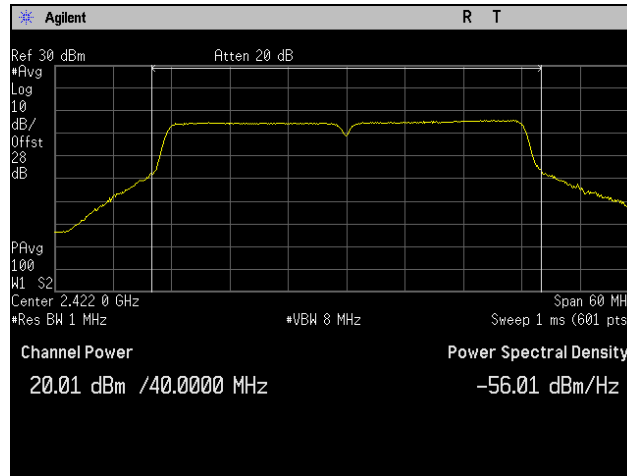

Plot 60. Peak Power Output, CDD, Low Channel, 802.11n 40 MHz, Port 2

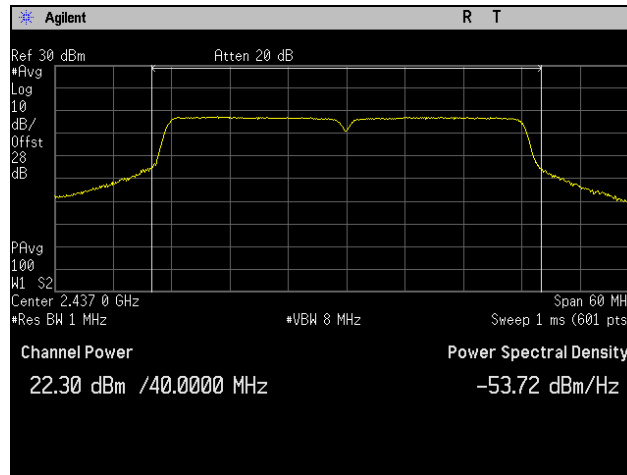

Plot 61. Peak Power Output, CDD, Mid Channel, 802.11n 40 MHz, Port 2

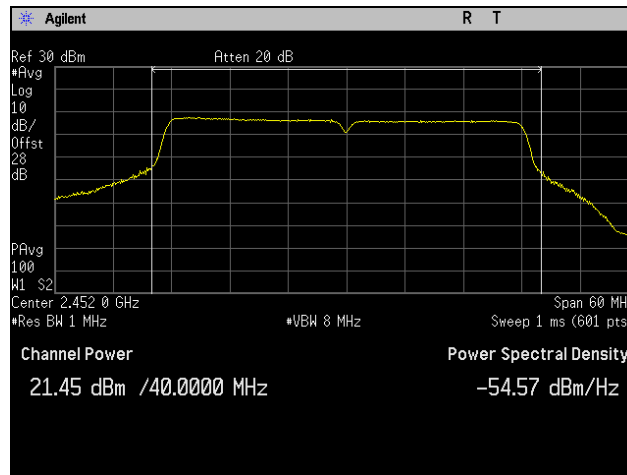

Plot 62. Peak Power Output, CDD, High Channel, 802.11n 40 MHz, Port 2

Peak Power Output, CDD, Test Results, 802.11n 20 MHz, Port 3

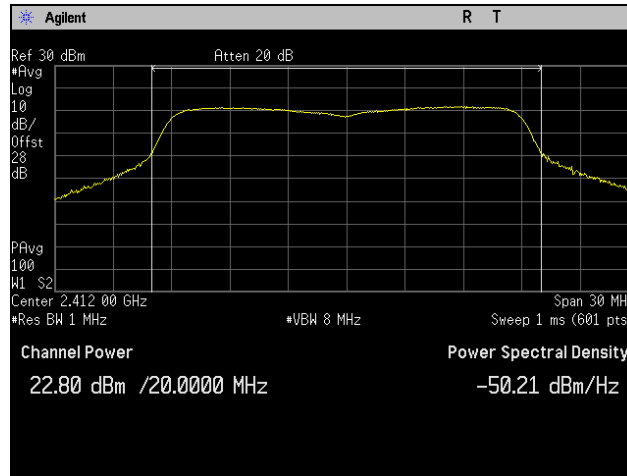

Plot 63. Peak Power Output, CDD, Low Channel, 802.11n 20 MHz, Port 3

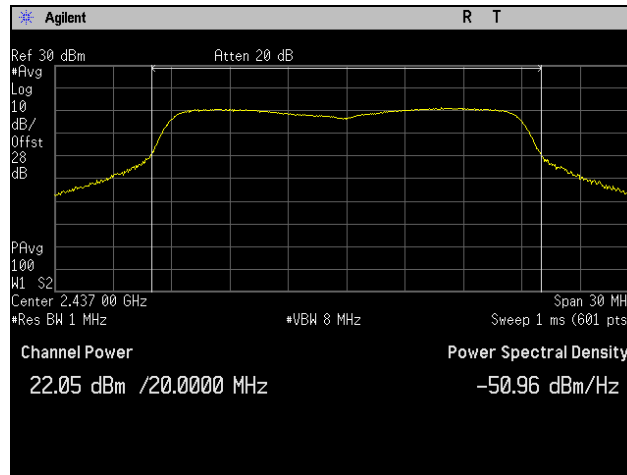

Plot 64. Peak Power Output, CDD, Mid Channel, 802.11n 20 MHz, Port 3

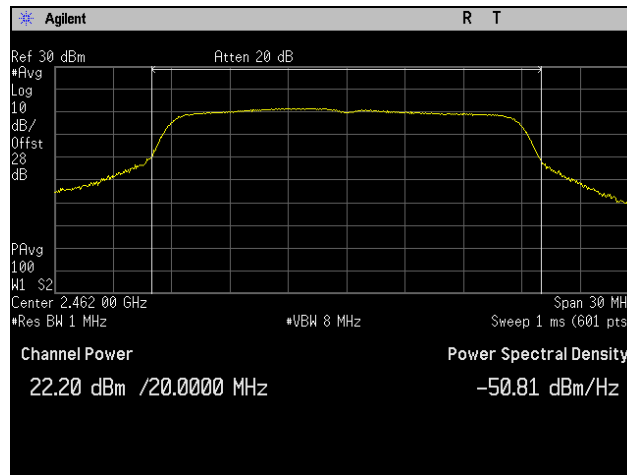

Plot 65. Peak Power Output, CDD, High Channel, 802.11n 20 MHz, Port 3

Peak Power Output, CDD, Test Results, 802.11n 40 MHz, Port 3

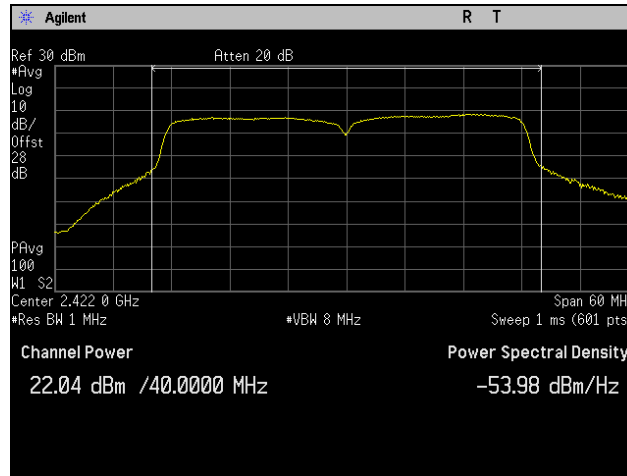

Plot 66. Peak Power Output, CDD, Low Channel, 802.11n 40 MHz, Port 3

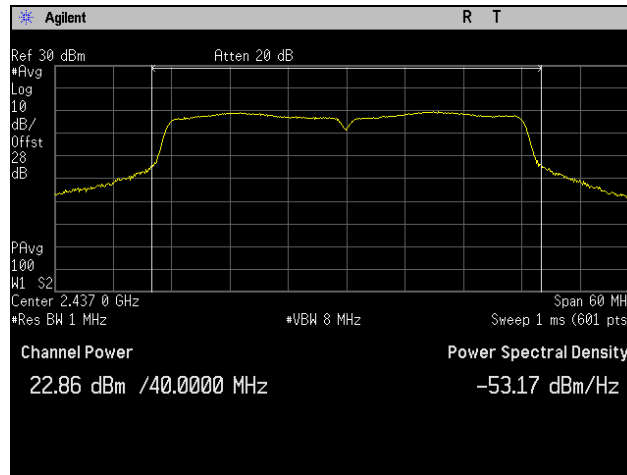

Plot 67. Peak Power Output, CDD, Mid Channel, 802.11n 40 MHz, Port 3

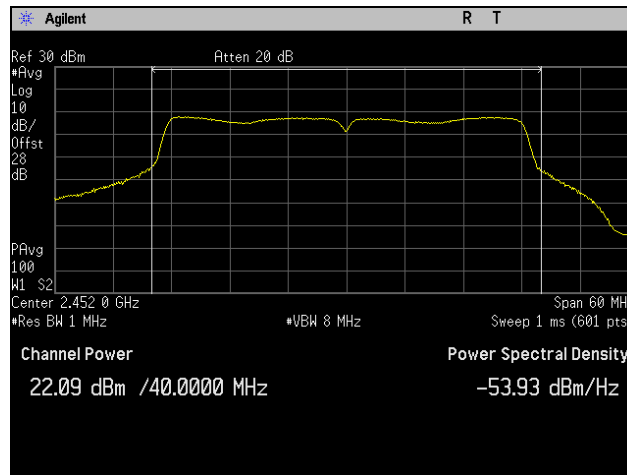

Plot 68. Peak Power Output, CDD, High Channel, 802.11n 40 MHz, Port 3

Electromagnetic Compatibility Criteria for Intentional Radiators

§ 15.247(d) Radiated Spurious Emissions Requirements and Band Edge

Test Requirements: §15.247(d); §15.205: Emissions outside the frequency band.

§15.247(d): In any 100 kHz bandwidth outside the frequency band in which the spread spectrum or digitally modulated intentional radiator is operating, the radio frequency power that is produced by the intentional radiator shall be at least 20 dB below that in the 100 kHz bandwidth within the band that contains the highest level of the desired power, based on either an RF conducted or a radiated measurement. Attenuation below the general limits specified in § 15.209(a) is not required. In addition, radiated emissions which fall in the restricted bands, as defined in § 15.205(a), must also comply with the radiated emission limits specified in § 15.209(a).

§15.205(a): Except as shown in paragraph (d) of this section, only spurious emissions are permitted in any of the frequency bands listed below:

MHz	MHz	MHz	GHz
0.090–0.110-----	16.42–16.423	399.9–410	4.5–5.15
¹ 0.495–0.505-----	16.69475–16.69525	608–614	5.35–5.46
2.1735–2.1905-----	16.80425–16.80475	960–1240	7.25–7.75
4.125–4.128-----	25.5–25.67	1300–1427	8.025–8.5
4.17725–4.17775-----	37.5–38.25	1435–1626.5	9.0–9.2
4.20725–4.20775-----	73–74.6	1645.5–1646.5	9.3–9.5
6.215–6.218-----	74.8–75.2	1660–1710	10.6–12.7
6.26775–6.26825-----	108–121.94	1718.8–1722.2	13.25–13.4
6.31175–6.31225-----	123–138	2200–2300	14.47–14.5
8.291–8.294-----	149.9–150.05	2310–2390	15.35–16.2
8.362–8.366-----	156.52475–156.52525	2483.5–2500	17.7–21.4
8.37625–8.38675-----	156.7–156.9	2655–2900	22.01–23.12
8.41425–8.41475-----	162.0125–167.17	3260–3267	23.6–24.0
12.29–12.293-----	167.72–173.2	3332–3339	31.2–31.8
12.51975–12.52025-----	240–285	3345.8–3358.36	43–36.5
12.57675–12.57725-----	322–335.4	3600–4400	(²)

Table 16. Restricted Bands of Operation

¹ Until February 1, 1999, this restricted band shall be 0.490 – 0.510 MHz.

² Above 38.6

Test Requirement(s): § 15.209 (a): Except as provided elsewhere in this subpart, the emissions from an intentional radiator shall not exceed the field strength levels specified in Table 17.

Frequency (MHz)	§ 15.209(a), Radiated Emission Limits (dB μ V) @ 3m
30 - 88	40.00
88 - 216	43.50
216 - 960	46.00
Above 960	54.00

Table 17. Radiated Emissions Limits Calculated from FCC Part 15, § 15.209 (a)

Test Procedures: The transmitter was turned on. Measurements were performed of the low, mid and high Channels. The EUT was rotated orthogonally through all three axes. Plots shown are corrected for both antenna correction factor and distance and compared to a 3 m limit line. Only noise floor was measured above 7 GHz.

Test Results: The EUT was compliant with the Radiated Spurious Emission limits of § 15.247(d).

Test Engineer(s): Surinder Singh

Test Date(s): 05/26/16

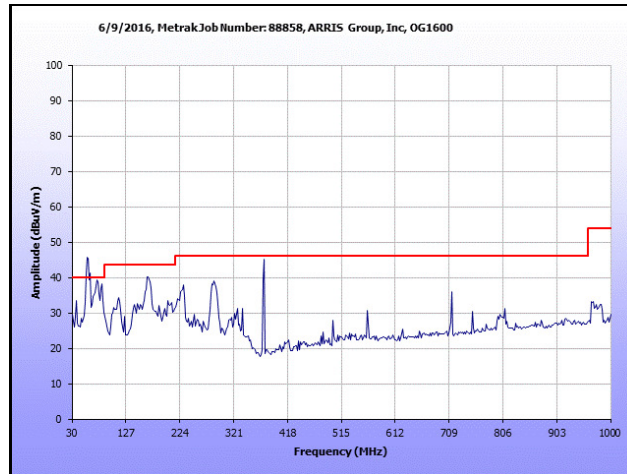

Plot 69. Radiated Spurious Emissions, 30 MHz – 1 GHz, Radio Off

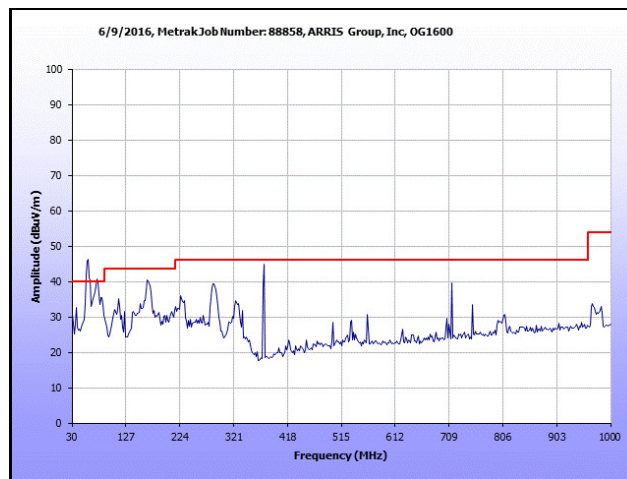

Plot 70. Radiated Spurious Emissions, 30 MHz – 1 GHz, Radio On

Radiated Spurious Emissions Test Results, 802.11b 20 MHz

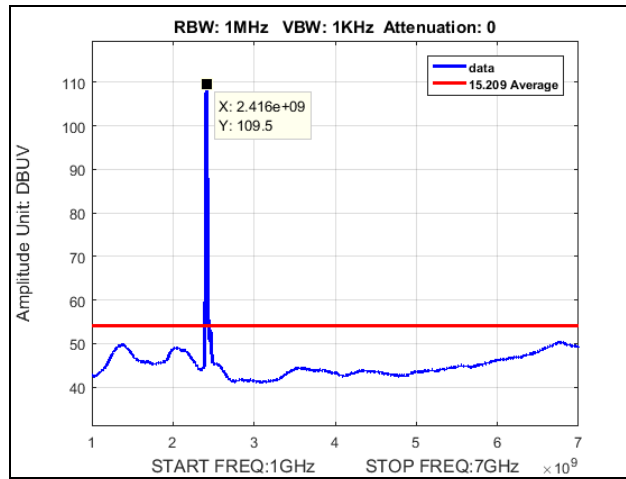

Plot 71. Radiated Spurious Emissions, Low Channel, 802.11b 20 MHz, 1 GHz – 7 GHz, Average

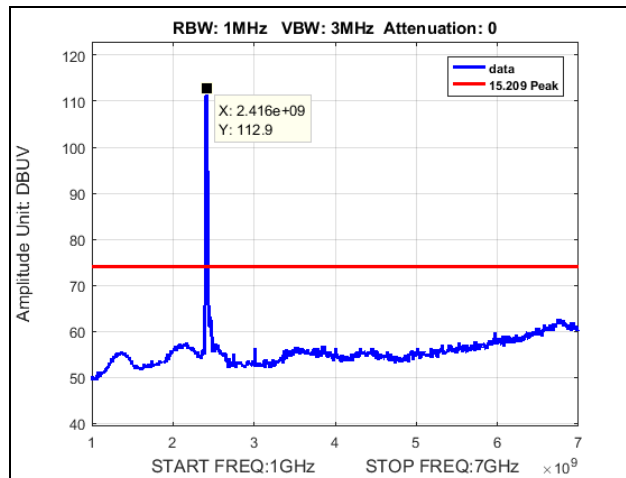

Plot 72. Radiated Spurious Emissions, Low Channel, 802.11b 20 MHz, 1 GHz – 7 GHz, Peak

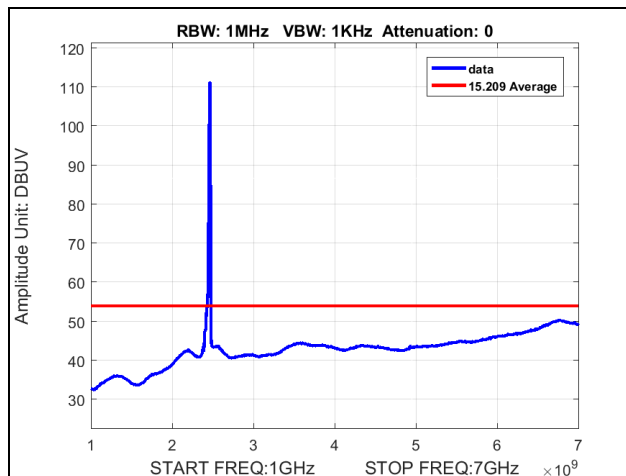

Plot 73. Radiated Spurious Emissions, Mid Channel, 802.11b 20 MHz, 1 GHz – 7 GHz, Average

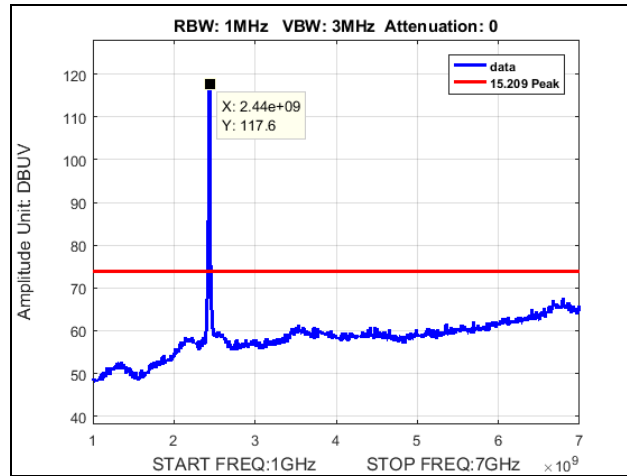

Plot 74. Radiated Spurious Emissions, Mid Channel, 802.11b 20 MHz, 1 GHz – 7 GHz, Peak

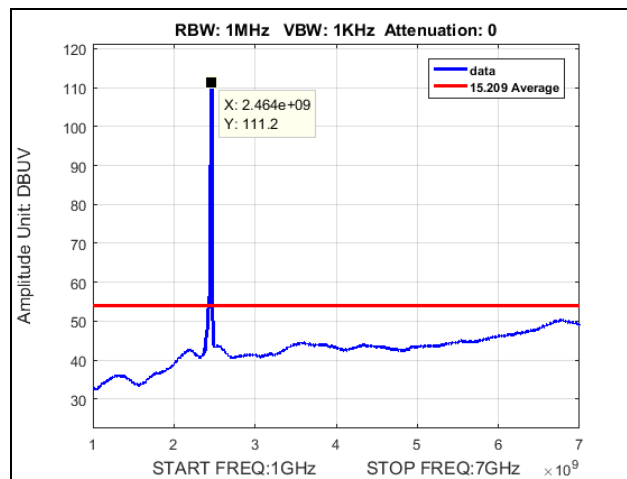

Plot 75. Radiated Spurious Emissions, High Channel, 802.11b 20 MHz, 1 GHz – 7 GHz, Average

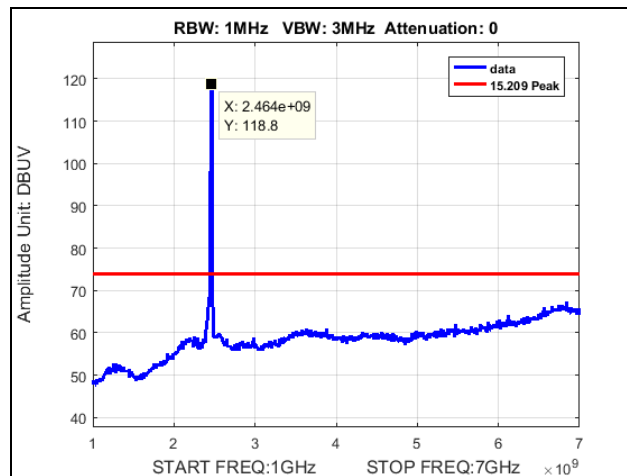

Plot 76. Radiated Spurious Emissions, High Channel, 802.11b 20 MHz, 1 GHz – 7 GHz, Peak

Radiated Spurious Emissions Test Results, 802.11g 20 MHz

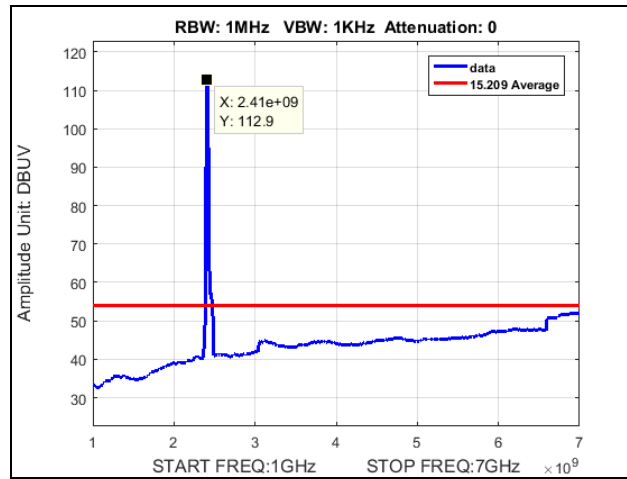

Plot 77. Radiated Spurious Emissions, Low Channel, 802.11g 20 MHz, 1 GHz – 7 GHz, Average

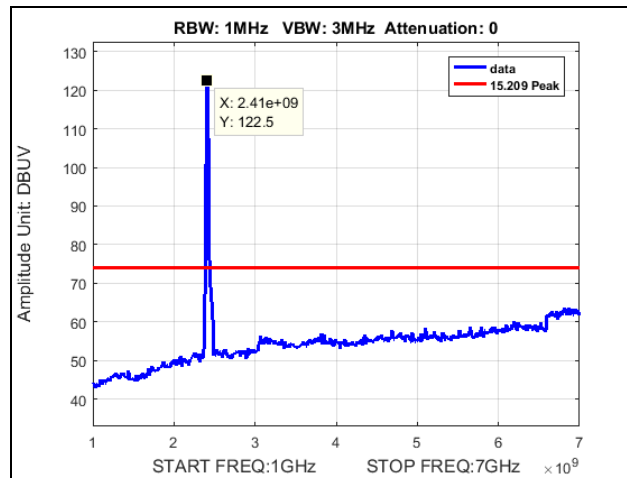

Plot 78. Radiated Spurious Emissions, Low Channel, 802.11g 20 MHz, 1 GHz – 7 GHz, Peak

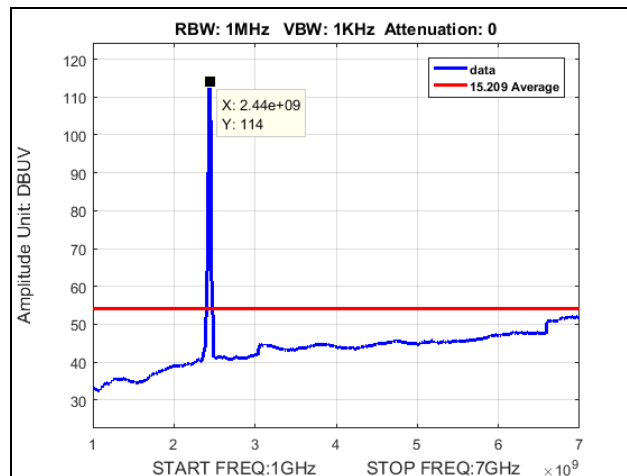

Plot 79. Radiated Spurious Emissions, Mid Channel, 802.11g 20 MHz, 1 GHz – 7 GHz, Average

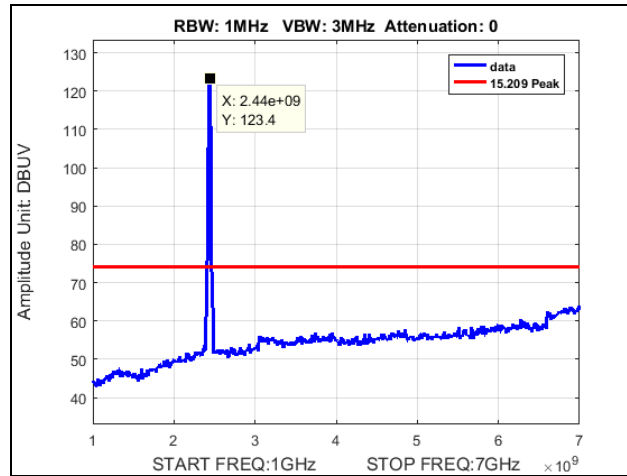

Plot 80. Radiated Spurious Emissions, Mid Channel, 802.11g 20 MHz, 1 GHz – 7 GHz, Peak

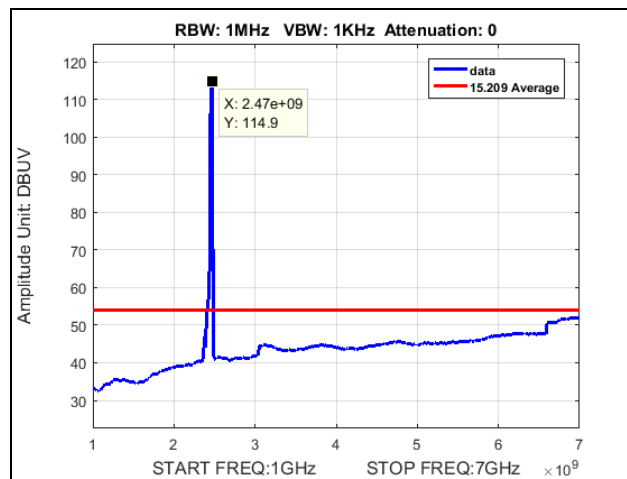

Plot 81. Radiated Spurious Emissions, High Channel, 802.11g 20 MHz, 1 GHz – 7 GHz, Average

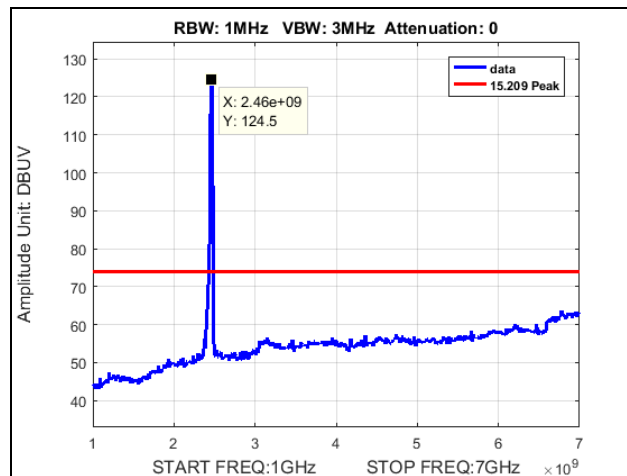

Plot 82. Radiated Spurious Emissions, High Channel, 802.11g 20 MHz, 1 GHz – 7 GHz, Peak

Radiated Spurious Emissions Test Results, 802.11n 20 MHz

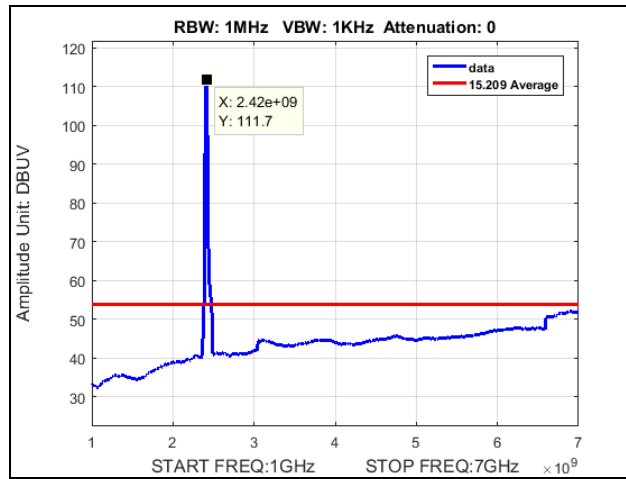

Plot 83. Radiated Spurious Emissions, Low Channel, 802.11n 20 MHz, 1 GHz – 7 GHz, Average

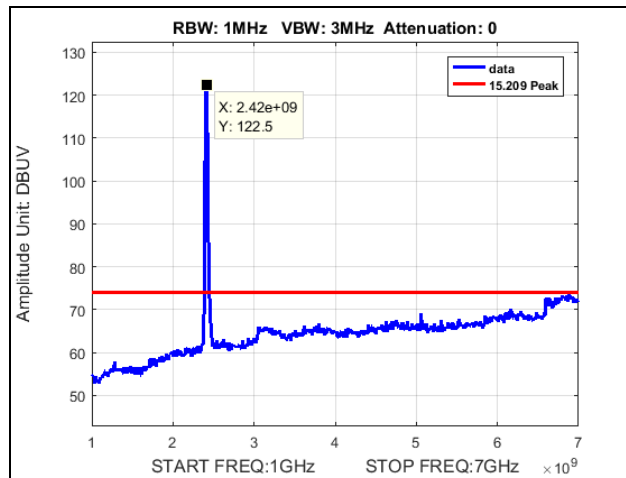

Plot 84. Radiated Spurious Emissions, Low Channel, 802.11n 20 MHz, 1 GHz – 7 GHz, Peak

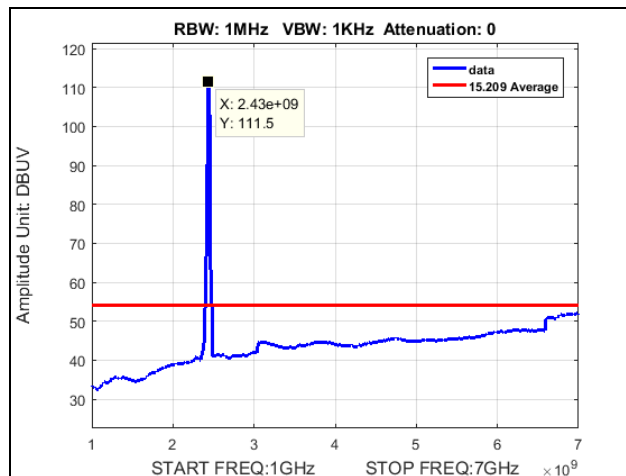

Plot 85. Radiated Spurious Emissions, Mid Channel, 802.11n 20 MHz, 1 GHz – 7 GHz, Average

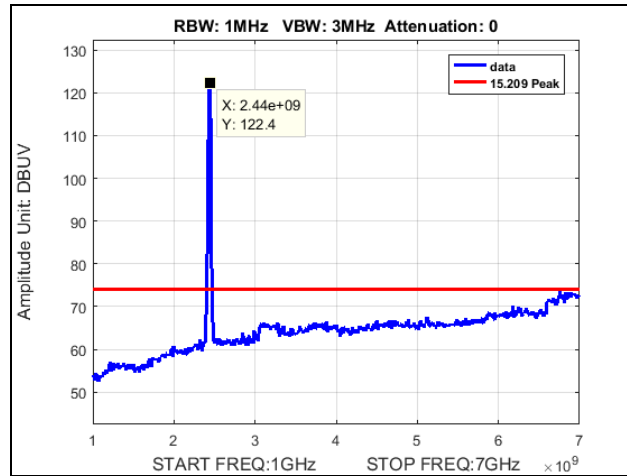

Plot 86. Radiated Spurious Emissions, Mid Channel, 802.11n 20 MHz, 1 GHz – 7 GHz, Peak

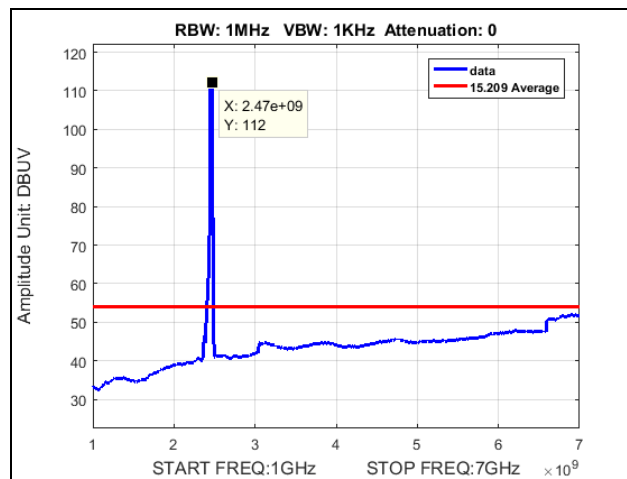

Plot 87. Radiated Spurious Emissions, High Channel, 802.11n 20 MHz, 1 GHz – 7 GHz, Average

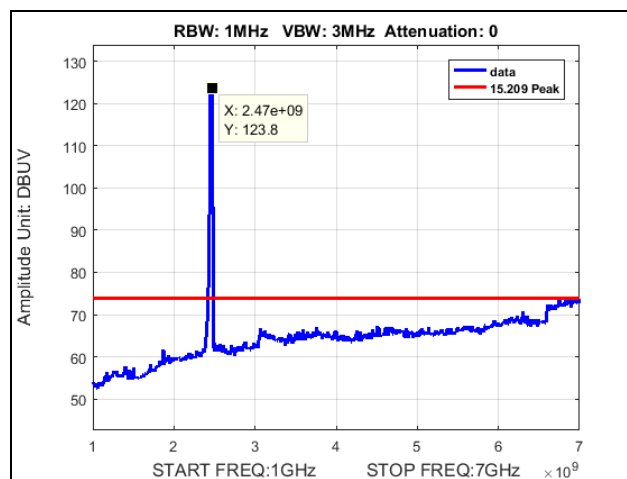

Plot 88. Radiated Spurious Emissions, High Channel, 802.11n 20 MHz, 1 GHz – 7 GHz, Peak

Radiated Spurious Emissions Test Results, 802.11n 40 MHz

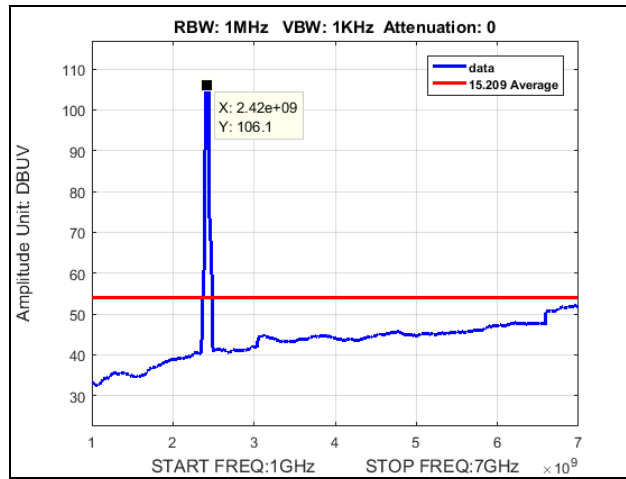

Plot 89. Radiated Spurious Emissions, Low Channel, 802.11n 40 MHz, 1 GHz – 7 GHz, Average

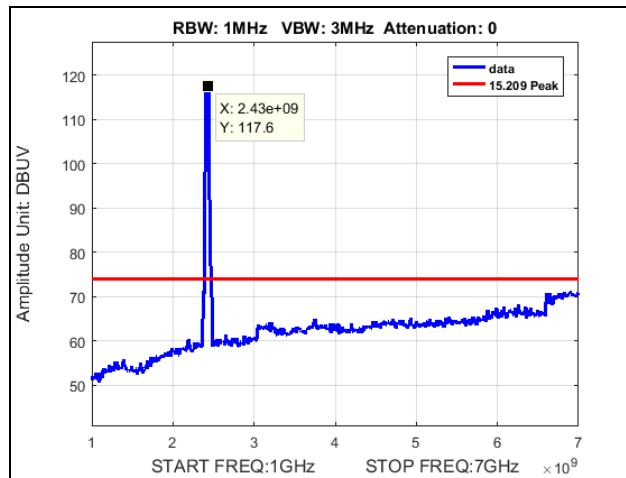

Plot 90. Radiated Spurious Emissions, Low Channel, 802.11n 40 MHz, 1 GHz – 7 GHz, Peak

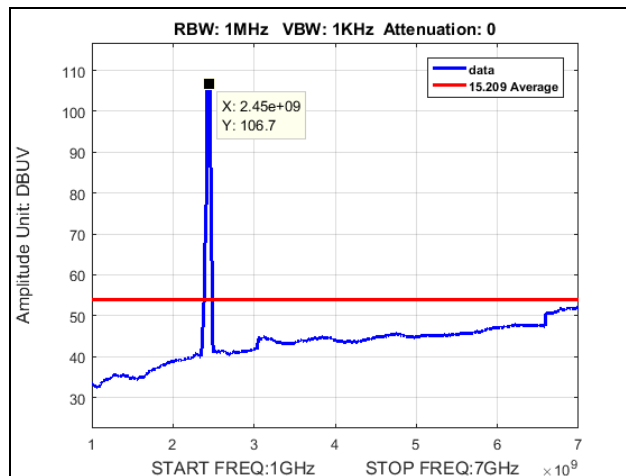

Plot 91. Radiated Spurious Emissions, Mid Channel, 802.11n 40 MHz, 1 GHz – 7 GHz, Average

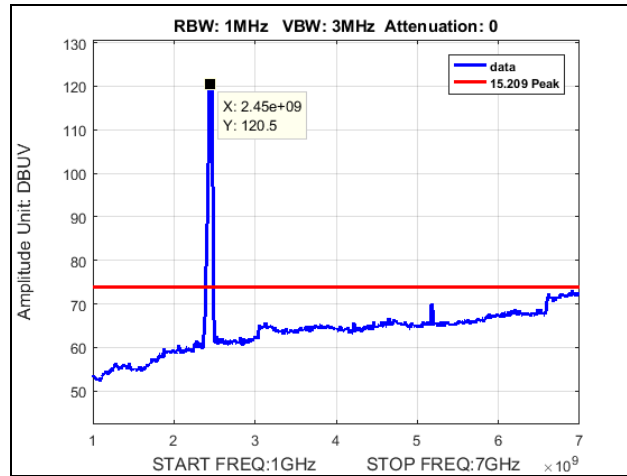

Plot 92. Radiated Spurious Emissions, Mid Channel, 802.11n 40 MHz, 1 GHz – 7 GHz, Peak

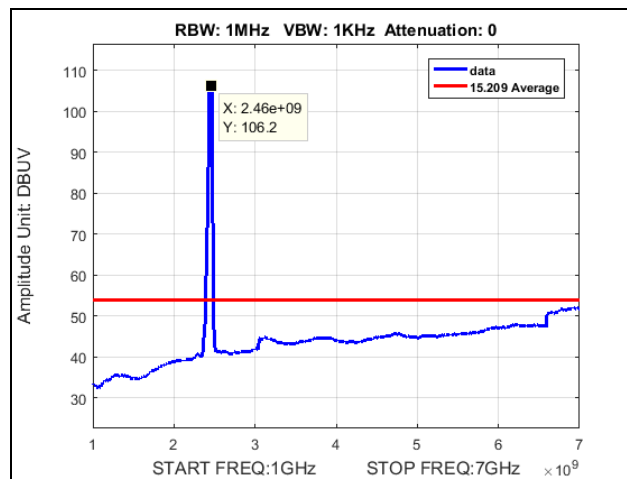

Plot 93. Radiated Spurious Emissions, High Channel, 802.11n 40 MHz, 1 GHz – 7 GHz, Average

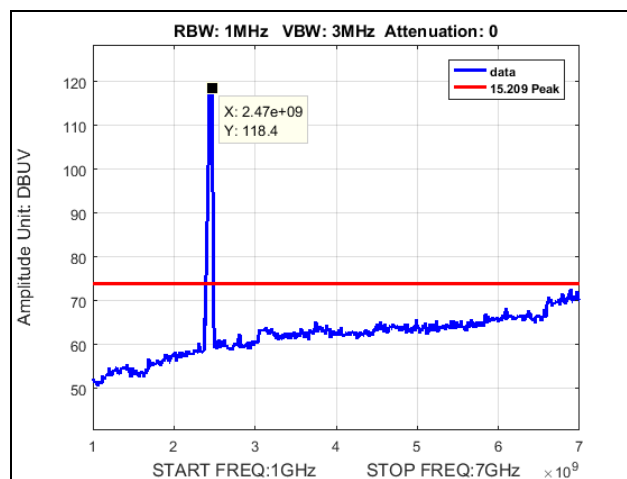

Plot 94. Radiated Spurious Emissions, High Channel, 802.11n 40 MHz, 1 GHz – 7 GHz, Peak

Radiated Band Edge Measurements

Test Procedures: The transmitter was turned on. Measurements were performed of the low and high Channels. The EUT was rotated orthogonally through all three axes. Plots shown are corrected for both antenna correction factor and distance and compared to a 3 m limit line.

Radiated Band Edge Measurements, 802.11b 20 MHz

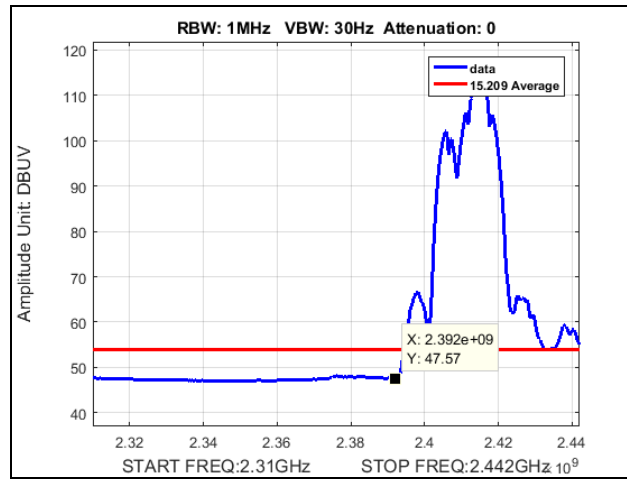

Plot 95. Radiated Restricted Band Edge, Low Channel, 802.11b 20 MHz, Average

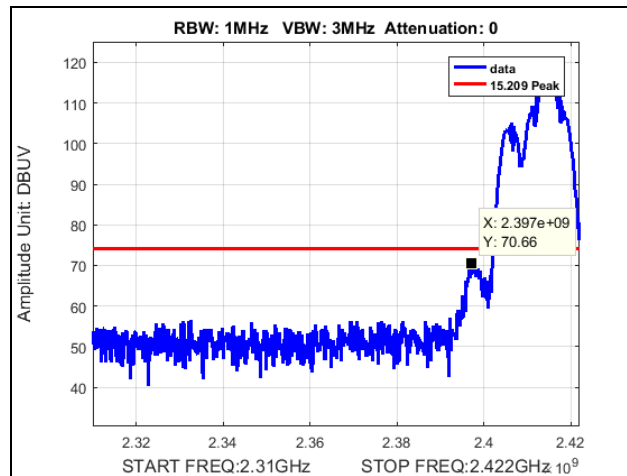

Plot 96. Radiated Restricted Band Edge, Low Channel, 802.11b 20 MHz, Peak

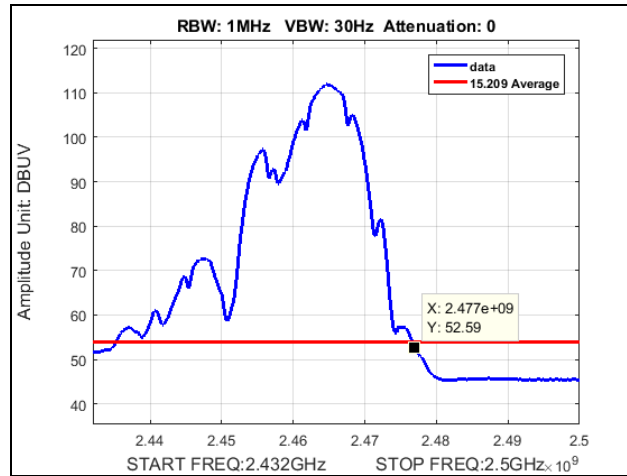

Plot 97. Radiated Restricted Band Edge, High Channel, 802.11b 20 MHz, Average

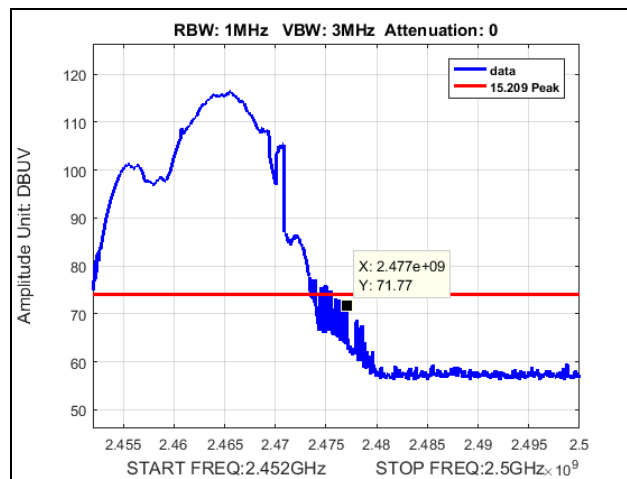

Plot 98. Radiated Restricted Band Edge, High Channel, 802.11b 20 MHz, Peak

Radiated Band Edge Measurements, 802.11g 20 MHz

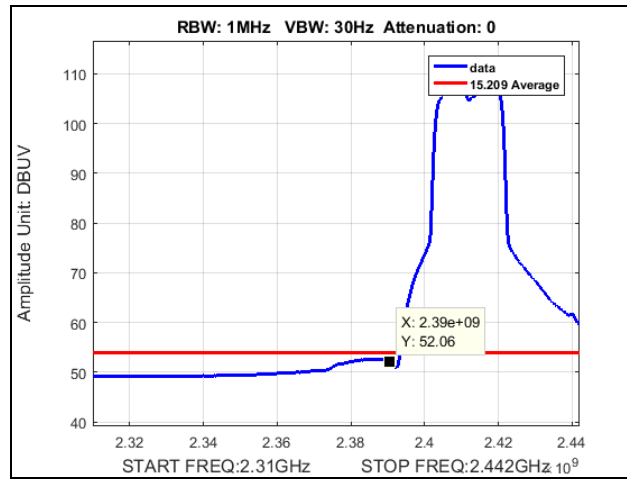

Plot 99. Radiated Restricted Band Edge, Low Channel, 802.11g 20 MHz, Average

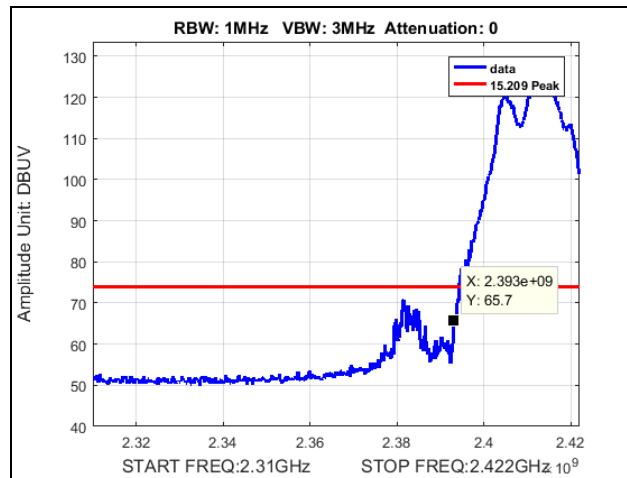

Plot 100. Radiated Restricted Band Edge, Low Channel, 802.11g 20 MHz, Peak

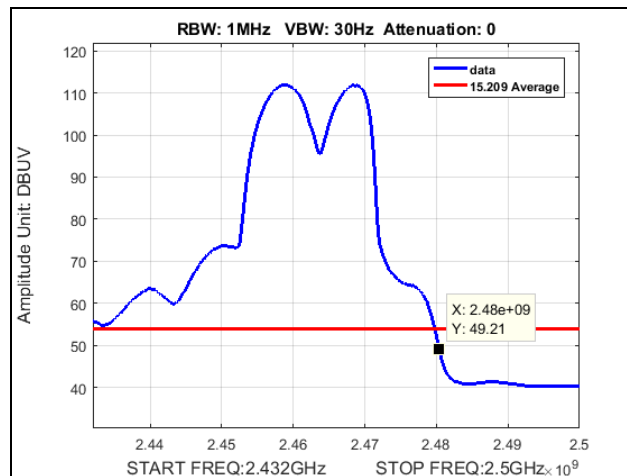

Plot 101. Radiated Restricted Band Edge, High Channel, 802.11g 20 MHz, Average

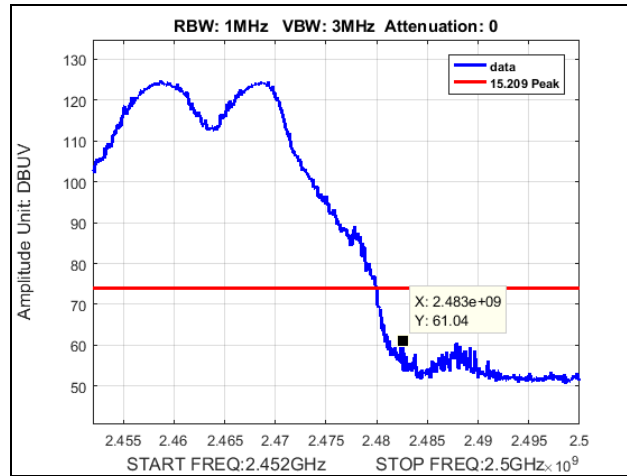

Plot 102. Radiated Restricted Band Edge, High Channel, 802.11g 20 MHz, Peak

Radiated Band Edge Measurements, 802.11n 20 MHz

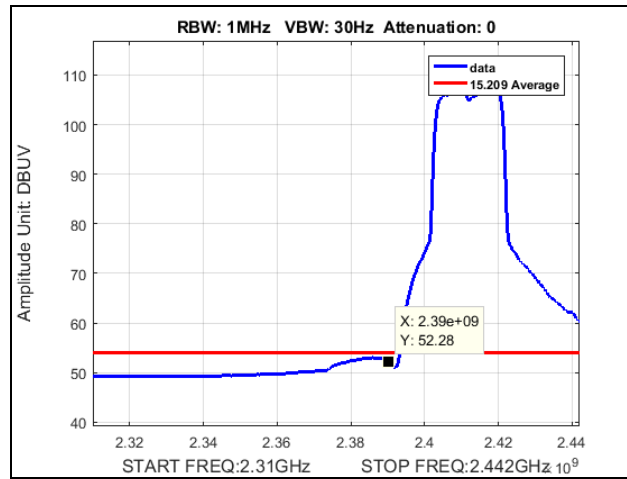

Plot 103. Radiated Restricted Band Edge, Low Channel, 802.11n 20 MHz, Average

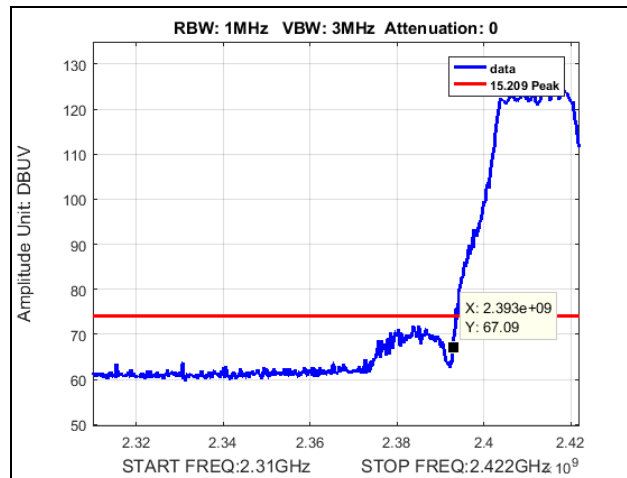

Plot 104. Radiated Restricted Band Edge, Low Channel, 802.11n 20 MHz, Peak

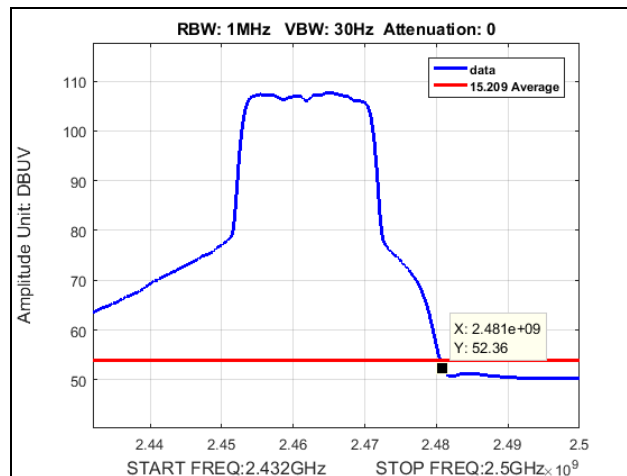

Plot 105. Radiated Restricted Band Edge, High Channel, 802.11n 20 MHz, Average

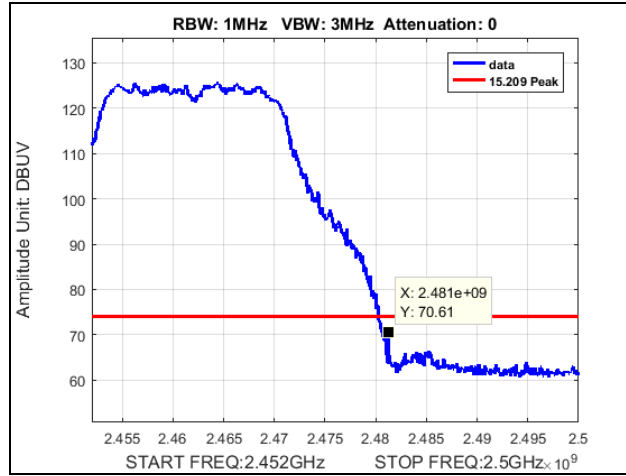

Plot 106. Radiated Restricted Band Edge, High Channel, 802.11n 20 MHz, Peak

Radiated Band Edge Measurements, 802.11n 40 MHz

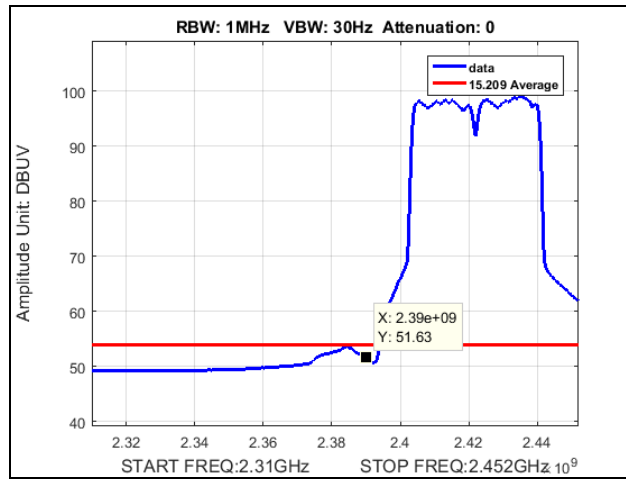

Plot 107. Radiated Restricted Band Edge, Low Channel, 802.11n 40 MHz, Average

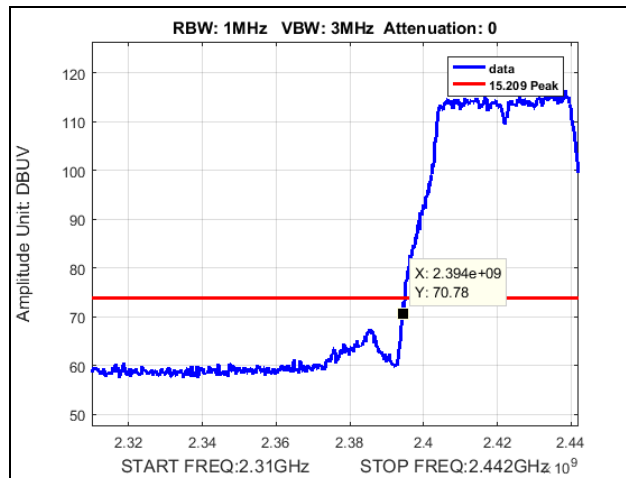

Plot 108. Radiated Restricted Band Edge, Low Channel, 802.11n 40 MHz, Peak

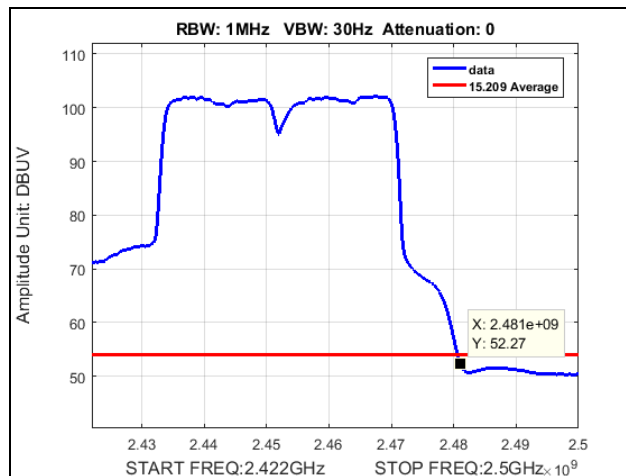

Plot 109. Radiated Restricted Band Edge, High Channel, 802.11n 40 MHz, Average

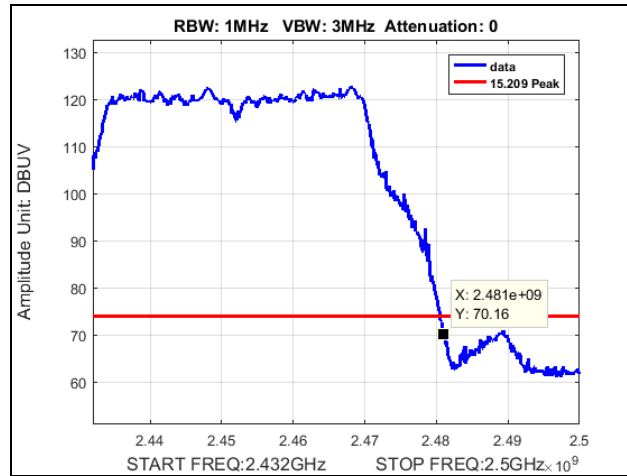

Plot 110. Radiated Restricted Band Edge, High Channel, 802.11n 40 MHz, Peak

Electromagnetic Compatibility Criteria for Intentional Radiators

§ 15.247(d) RF Conducted Spurious Emissions Requirements and Band Edge

Test Requirement: **15.247(d)** In any 100 kHz bandwidth outside the frequency band in which the spread spectrum or digitally modulated intentional radiator is operating, the radio frequency power that is produced by the intentional radiator shall be at least 20 dB below that in the 100 kHz bandwidth within the band that contains the highest level of the desired power, based on either an RF conducted or a radiated measurement, provided the transmitter demonstrates compliance with the peak conducted power limits. If the transmitter complies with the conducted power limits based on the use of RMS averaging over a time interval, as permitted under paragraph (b)(3) of this section, the attenuation required under this paragraph shall be 30 dB instead of 20 dB.

Test Procedure: For intentional radiators with a digital device portion which operates below 10 GHz, the spectrum was investigated as per §15.33(a)(1) and §15.33(a)(4); i.e., the lowest RF signal generated or used in the device up to the 10th harmonic of the highest fundamental frequency or to 40 GHz, whichever is lower.

See following pages for detailed test results with RF Conducted Spurious Emissions.

Test Results: The EUT was compliant with the Conducted Spurious Emission limits of §15.247(d).

Test Engineer(s): Surinder Singh

Test Date(s): 05/26/16

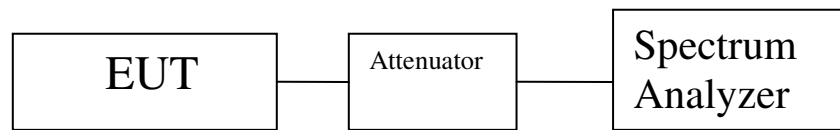
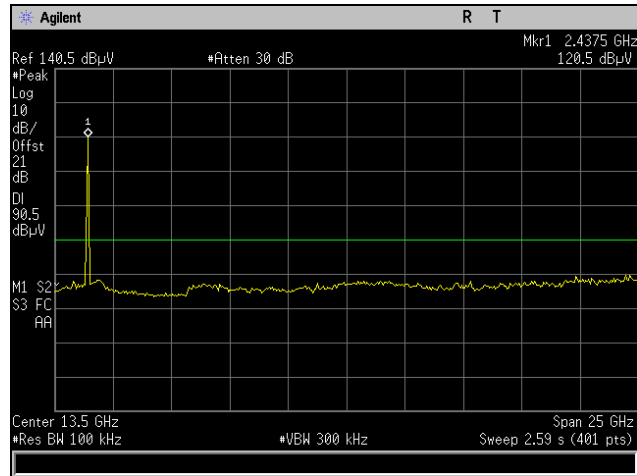
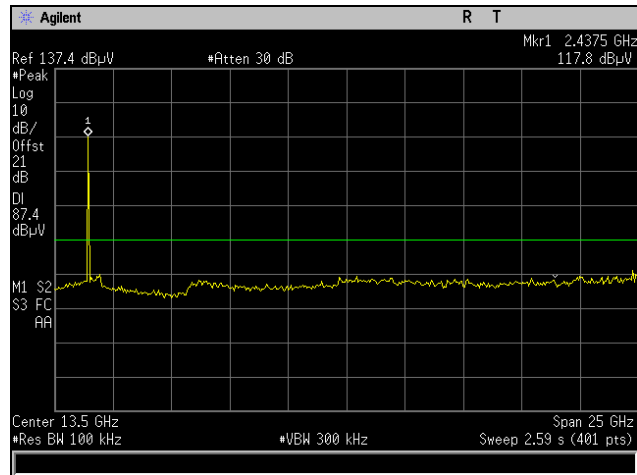

Figure 4. Block Diagram, Conducted Spurious Emissions Test Setup

Conducted Spurious Emissions Test Results, 802.11b 20 MHz



Plot 111. Conducted Spurious Emissions, Low Channel, 802.11b 20 MHz, 1 GHz – 18 GHz



Plot 112. Conducted Spurious Emissions, Mid Channel, 802.11b 20 MHz, 1 GHz – 18 GHz

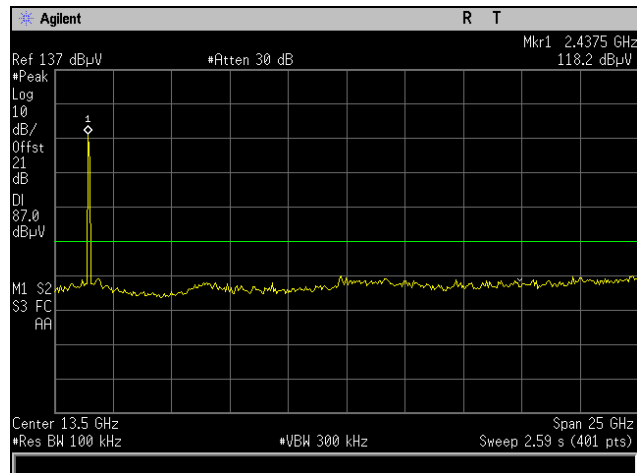

Plot 113. Conducted Spurious Emissions, High Channel, 802.11b 20 MHz, 1 GHz – 18 GHz

Conducted Spurious Emissions Test Results, 802.11g 20 MHz

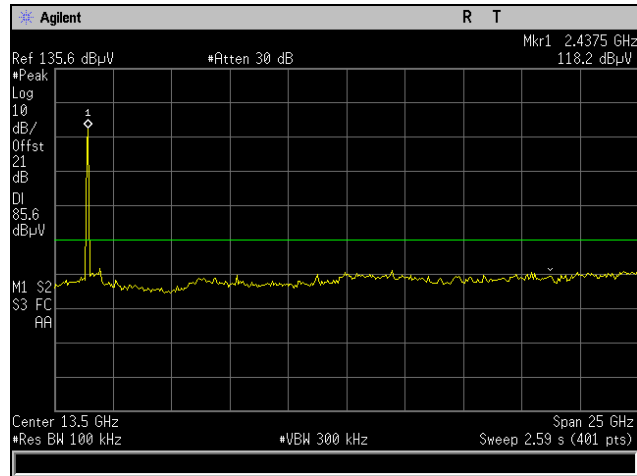

Plot 114. Conducted Spurious Emissions, Low Channel, 802.11g 20 MHz, 1 GHz – 18 GHz

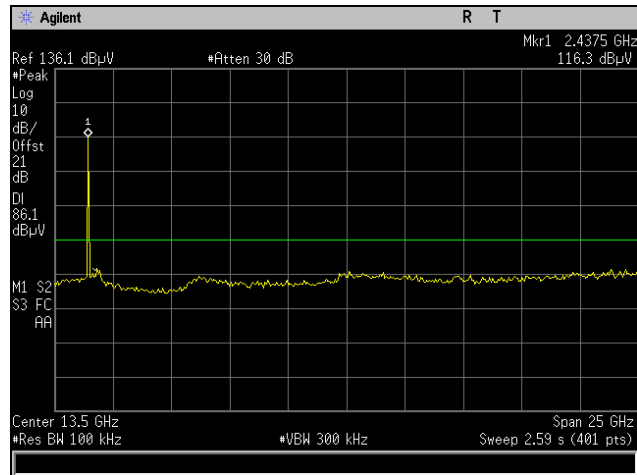

Plot 115. Conducted Spurious Emissions, Mid Channel, 802.11g 20 MHz, 1 GHz – 18 GHz

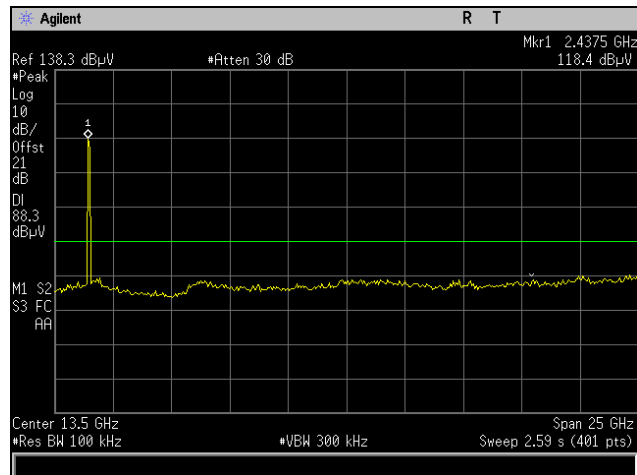

Plot 116. Conducted Spurious Emissions, High Channel, 802.11g20 MHz, 1 GHz – 18 GHz

Conducted Spurious Emissions Test Results, 802.11n 20 MHz

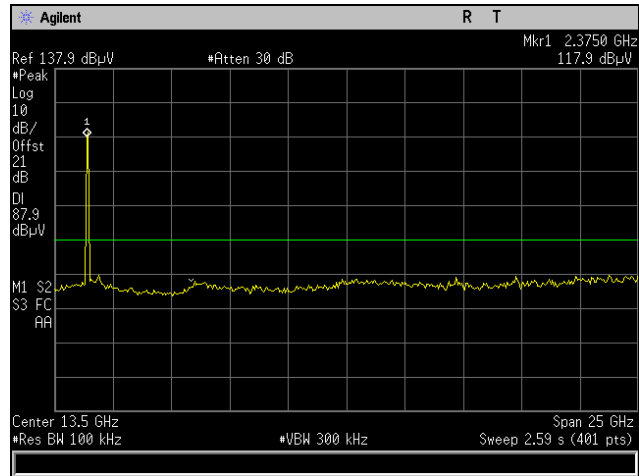

Plot 117. Conducted Spurious Emissions, Low Channel, 802.11n 20 MHz, 1 GHz – 18 GHz

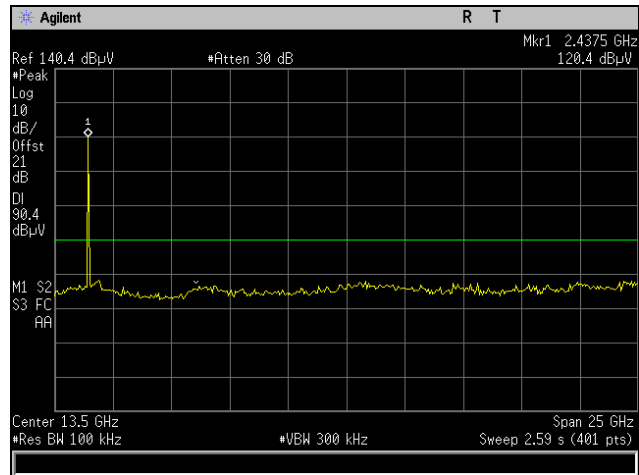

Plot 118. Conducted Spurious Emissions, Mid Channel, 802.11n 20 MHz, 1 GHz – 18 GHz

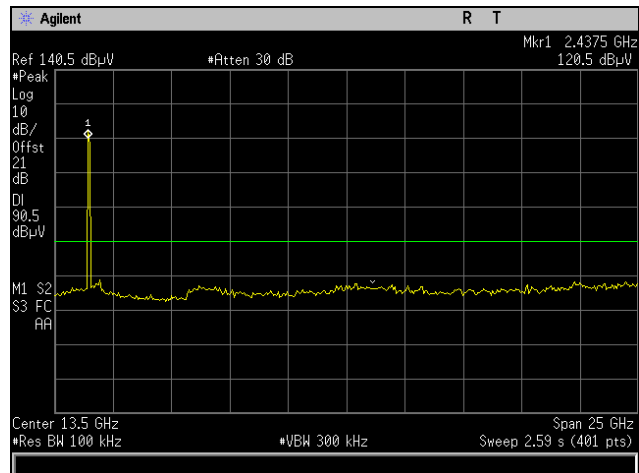

Plot 119. Conducted Spurious Emissions, High Channel, 802.11n 20 MHz, 1 GHz – 18 GHz

Conducted Spurious Emissions Test Results, 802.11n 40 MHz

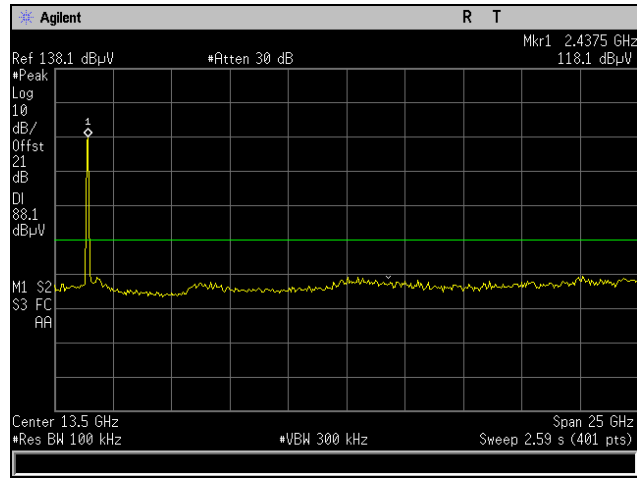

Plot 120. Conducted Spurious Emissions, Low Channel, 802.11n 40 MHz, 1 GHz – 18 GHz

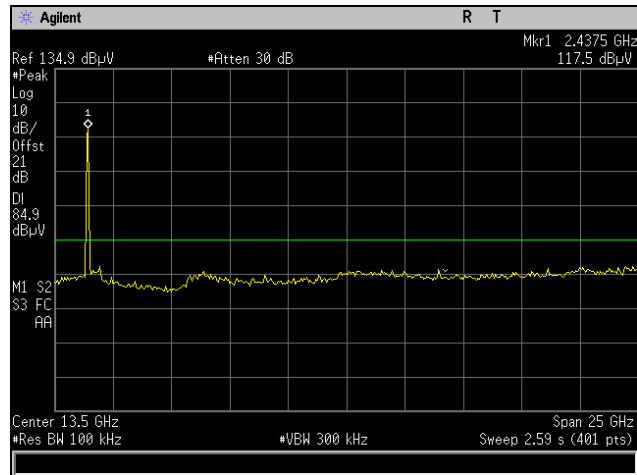

Plot 121. Conducted Spurious Emissions, Mid Channel, 802.11n 40 MHz, 1 GHz – 18 GHz

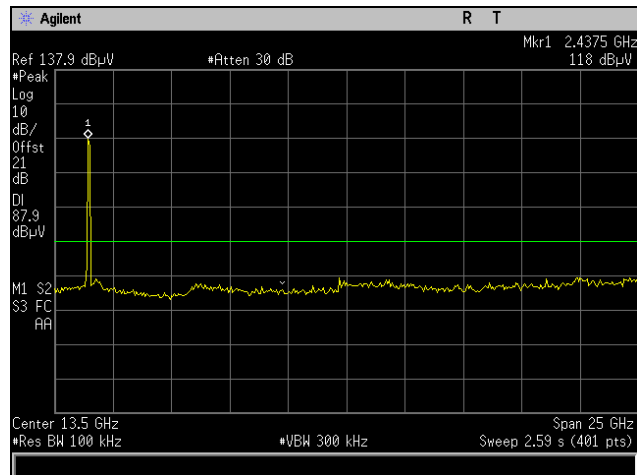

Plot 122. Conducted Spurious Emissions, High Channel, 802.11n 40 MHz, 1 GHz – 18 GHz

Conducted Band Edge Test Results, 802.11b 20 MHz

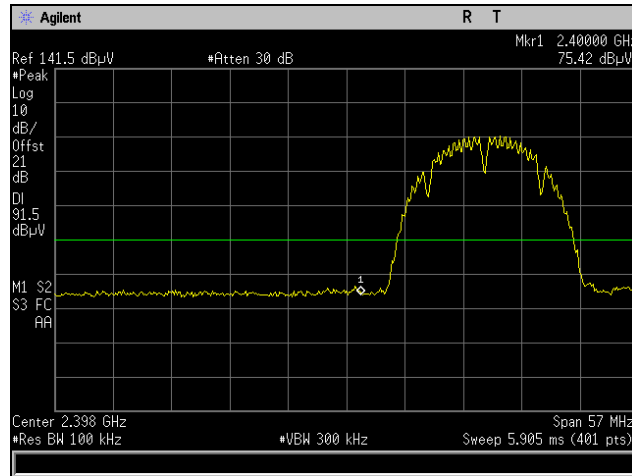

Plot 123. Conducted Band Edge, Low Channel, 802.11b 20 MHz

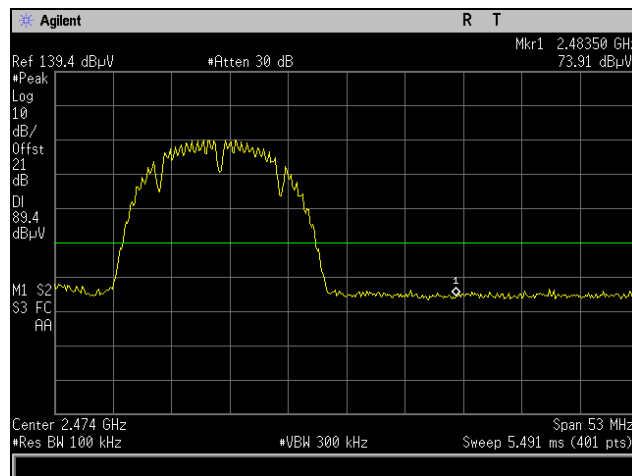

Plot 124. Conducted Band Edge, High Channel, 802.11b 20 MHz

Conducted Band Edge Test Results, 802.11g 20 MHz

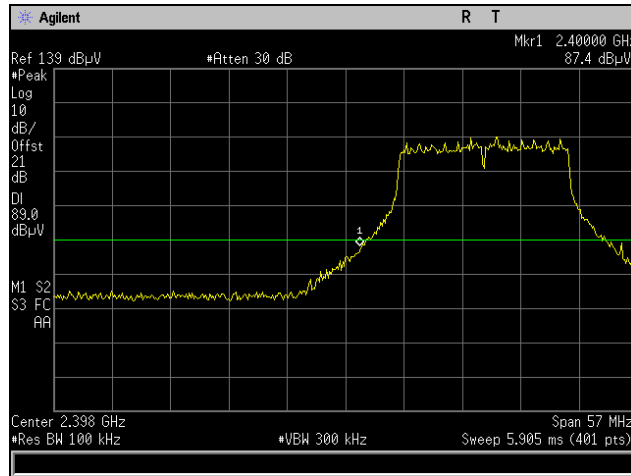

Plot 125. Conducted Band Edge, Low Channel, 802.11g 20 MHz

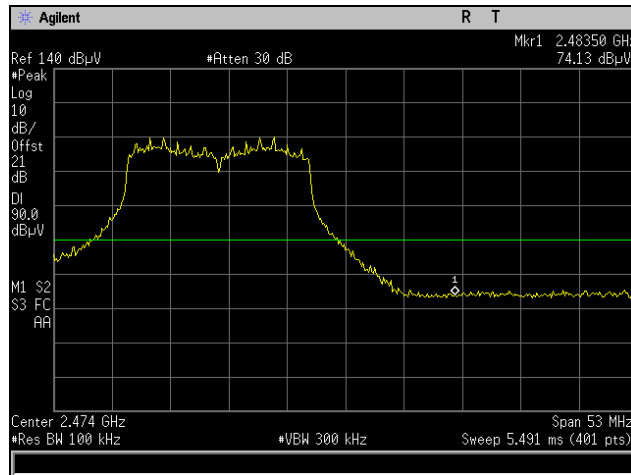

Plot 126. Conducted Band Edge, High Channel, 802.11g 20 MHz

Conducted Band Edge Test Results, 802.11n 20 MHz

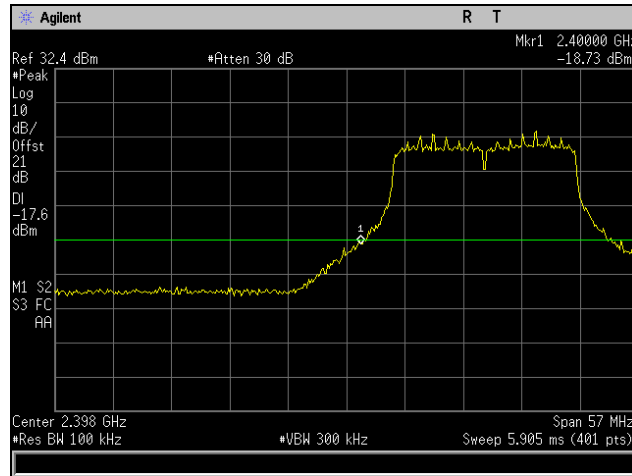

Plot 127. Conducted Band Edge, Low Channel, 802.11n 20 MHz

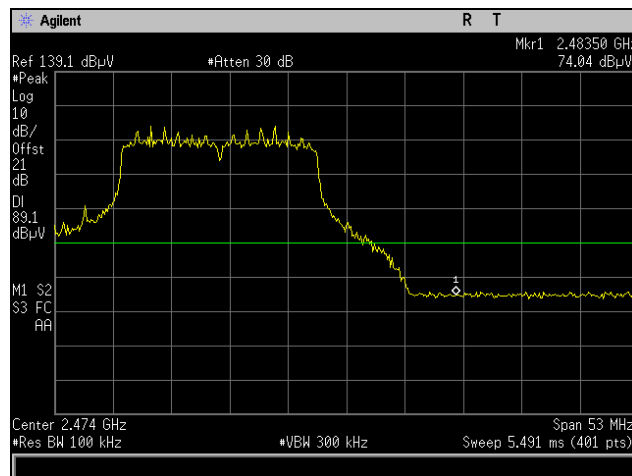

Plot 128. Conducted Band Edge, High Channel, 802.11n 20 MHz

Conducted Band Edge Test Results, 802.11n 40 MHz

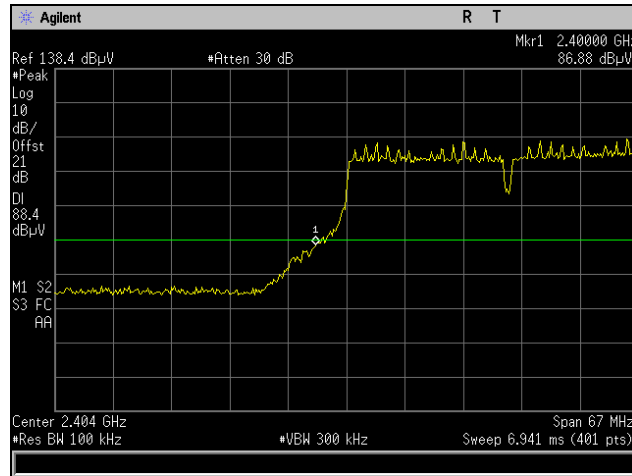

Plot 129. Conducted Band Edge, Low Channel, 802.11n 40 MHz

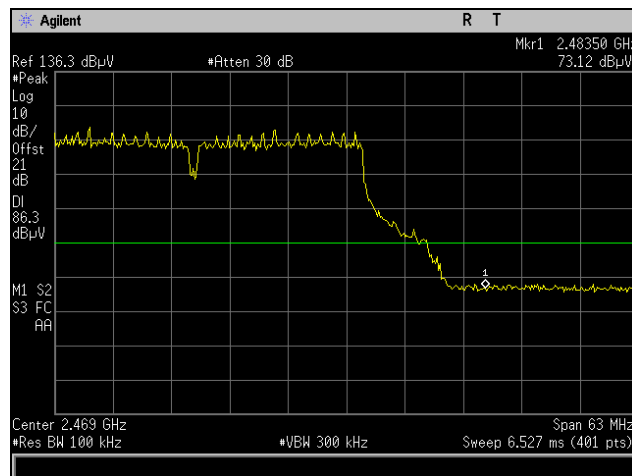

Plot 130. Conducted Band Edge, High Channel, 802.11n 40 MHz

Electromagnetic Compatibility Criteria for Intentional Radiators

§ 15.247(e) Peak Power Spectral Density

Test Requirements: §15.247(e): For digitally modulated systems, the peak power spectral density conducted from the intentional radiator to the antenna shall not be greater than 8dBm in any 3 kHz band during any time interval of continuous transmission.

Test Procedure: The transmitter was connected directly to a Spectrum Analyzer through an attenuator. The power level was set to the maximum level throughout each of the 100 sweeps of power averaging. The RBW was set to 3 kHz and a VBW set to 9 kHz or greater. The spectrum analyzer was set to an auto sweep time and a peak detector was used. Measurements were carried out at the low, mid and high channels.

The antenna gain was calculated based on whether the data was correlated or not per KDB 662911. For b and g mode the data is correlated and thus the gain is equal to the array gain of all three antennas. For n mode the data is completely uncorrelated and thus the gain is the single antenna gain

The Methods of KDB558074 section 10.2 were used

Test Results: The EUT was compliant with the peak power spectral density limits of § 15.247 (e).

The peak power spectral density was determined from plots on the following page(s).

Test Engineer: Surinder Singh

Test Date: 05/26/16

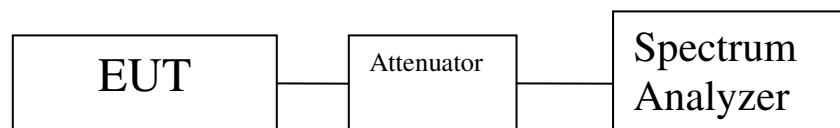

Figure 5. Block Diagram, Peak Power Spectral Density Test Setup

Peak Power Spectral Density Test Results

Center Frequency	Bandwidth	Mode	Transmission Scheme	Port 1 Data (dBm)	Port 2 Data (dBm)	Port 3 Data (dBm0)	Sum of Three Port (dBm)	Limit (dBm)	Antenna Gain (dBi)	Final limit (dBm)	Margin dB
Ch 2412M	BW 20M	b mode	CDD	-2.52	-2.15	-0.38	3.2	8	8.64	5.36	-2.16
Ch 2412M	BW 20M	g mode	CDD	-2.85	-4.47	-2.07	1.76	8	8.64	5.36	-3.6
Ch 2412M	BW 20M	n mode	CDD	-2.94	-4.87	-2.62	1.41	8	8.64	5.36	-3.95
Ch 2412M	BW 20M	n mode	SDM	-3.24	-3.93	-3.17	1.34	8	3.88	8	-6.66
Ch 2437M	BW 20M	b mode	CDD	-0.29	-3.05	-0.79	3.55	8	8.64	5.36	-1.81
Ch 2437M	BW 20M	g mode	CDD	-2.95	-3.17	-4.55	1.28	8	8.64	5.36	-4.08
Ch 2437M	BW 20M	n mode	CDD	-3.5	-4.38	-3.29	1.08	8	8.64	5.36	-4.28
Ch 2437M	BW 20M	n mode	SDM	-1.67	-2.55	-1.91	2.75	8	3.88	8	-5.25
Ch 2462M	BW 20M	b mode	CDD	-1.3	-1.8	-1.88	3.12	8	8.64	5.36	-2.24
Ch 2462M	BW 20M	g mode	CDD	-3.02	-3.78	-3.15	1.47	8	8.64	5.36	-3.89
Ch 2462M	BW 20M	n mode	CDD	-3.9	-3.6	-3.59	1.08	8	8.64	5.36	-4.28
Ch 2462M	BW 20M	n mode	SDM	0.18	-2.3	-2.02	3.54	8	3.88	8	-4.46
Ch 2422M	BW 40M	n mode	CDD	-4.93	-8.65	-6.76	-1.74	8	8.64	5.36	-7.1
Ch 2422M	BW 40M	n mode	SDM	-6.76	-7.82	-6.93	-2.37	8	3.88	8	-10.37
Ch 2437M	BW 40M	n mode	CDD	-3.8	-7.62	-6.23	-0.81	8	8.64	5.36	-6.17
Ch 2437M	BW 40M	n mode	SDM	-4.95	-6.93	-4.99	-0.75	8	3.88	8	-8.75
Ch 2452M	BW 40M	n mode	CDD	-4.61	-7.91	-6.38	-1.32	8	8.64	5.36	-6.68
Ch 2452M	BW 40M	n mode	SDM	-4.69	-4.36	-4.32	0.32	8	3.88	8	-7.68

Table 18. Peak Power Spectral Density, Test Results

Peak Power Spectral Density Test Results, 802.11b 20 MHz, Port 1

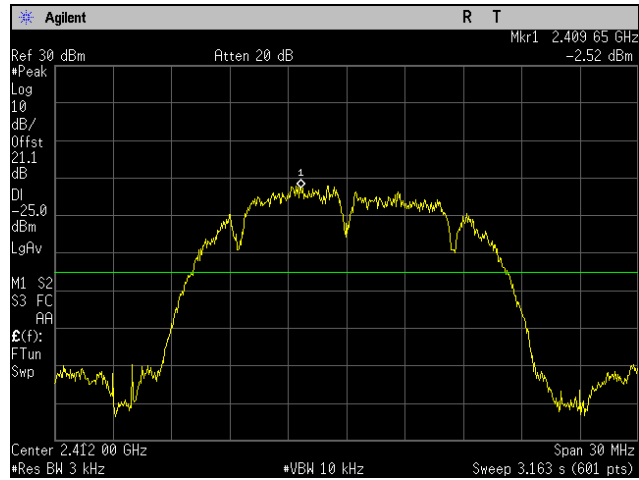

Plot 131. Peak Power Spectral Density, Low Channel, 802.11b 20 MHz, Port 1

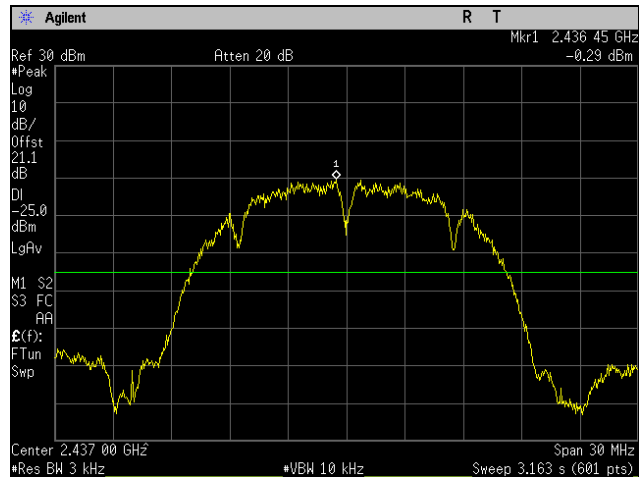

Plot 132. Peak Power Spectral Density, Mid Channel, 802.11b 20 MHz, Port 1

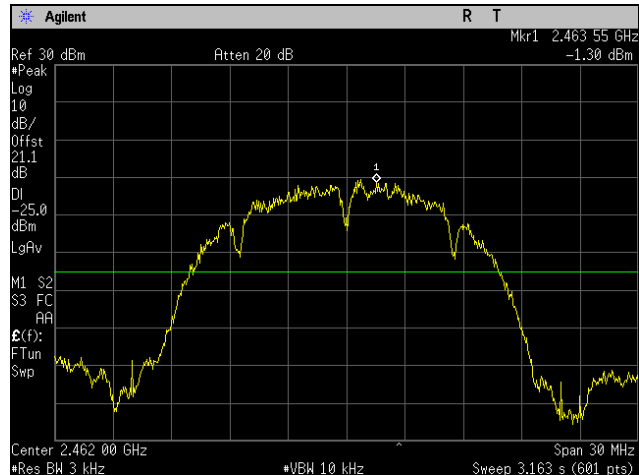

Plot 133. Peak Power Spectral Density, High Channel, 802.11b 20 MHz, Port 1

Peak Power Spectral Density Test Results, 802.11g 20 MHz, Port 1

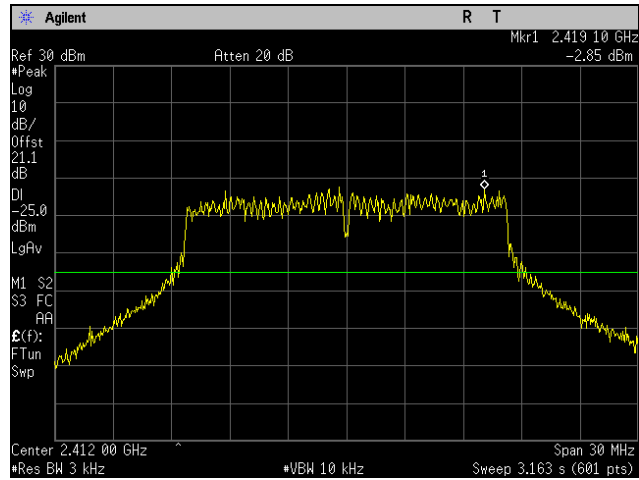

Plot 134. Peak Power Spectral Density, Low Channel, 802.11g 20 MHz, Port 1

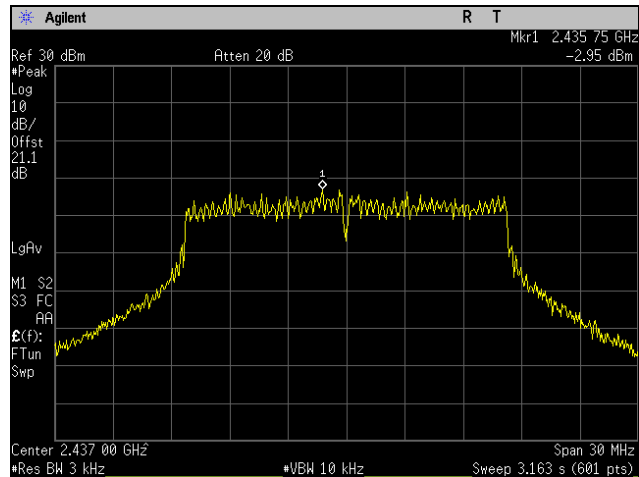

Plot 135. Peak Power Spectral Density, Mid Channel, 802.11g 20 MHz, Port 1

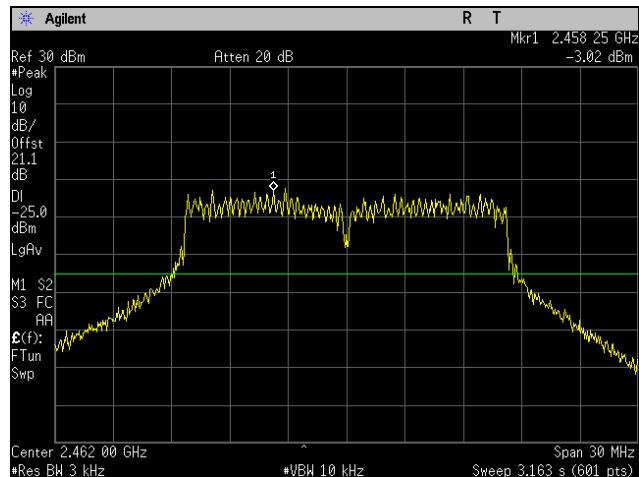

Plot 136. Peak Power Spectral Density, High Channel, 802.11g 20 MHz, Port 1

Peak Power Spectral Density Test Results, 802.11n 20 MHz, Port 1

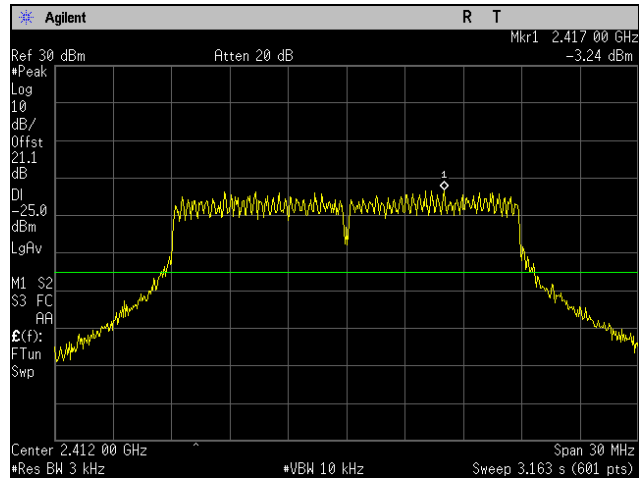

Plot 137. Peak Power Spectral Density, Low Channel, 802.11n 20 MHz, Port 1

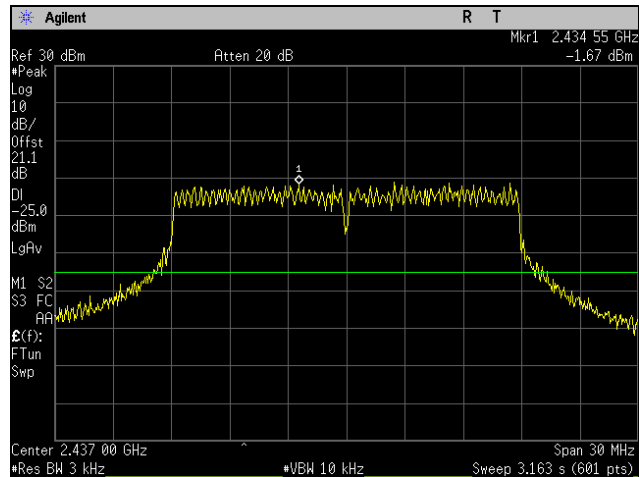

Plot 138. Peak Power Spectral Density, Mid Channel, 802.11n 20 MHz, Port 1

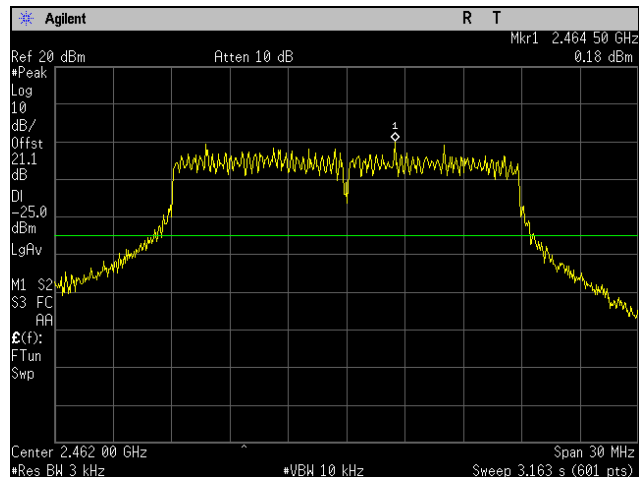

Plot 139. Peak Power Spectral Density, High Channel, 802.11n 20 MHz, Port 1

Peak Power Spectral Density Test Results, 802.11n 40 MHz, Port 1

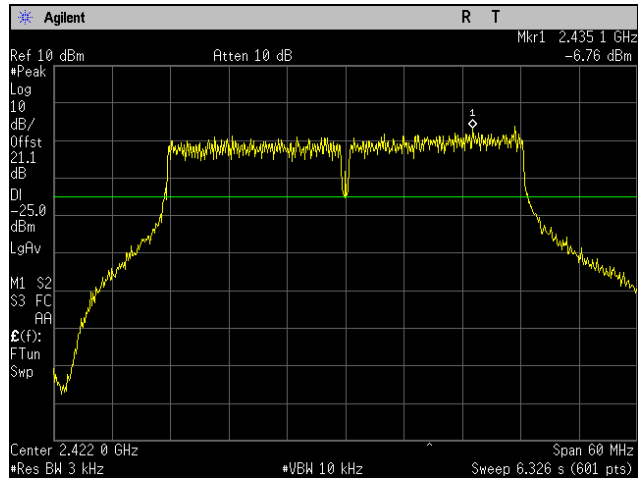

Plot 140. Peak Power Spectral Density, Low Channel, 802.11n 40 MHz, Port 1

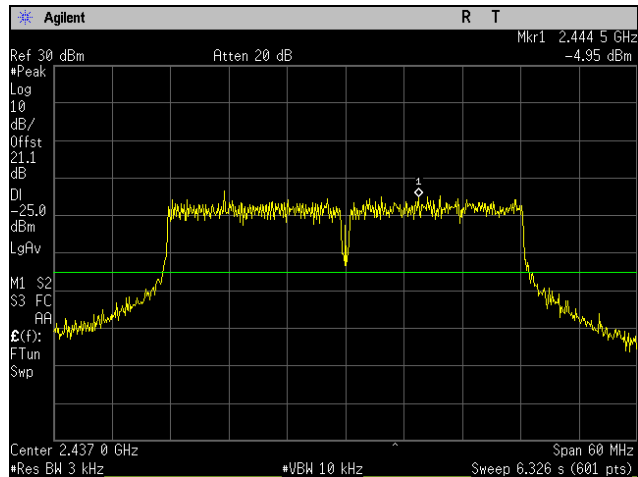

Plot 141. Peak Power Spectral Density, Mid Channel, 802.11n 40 MHz, Port 1

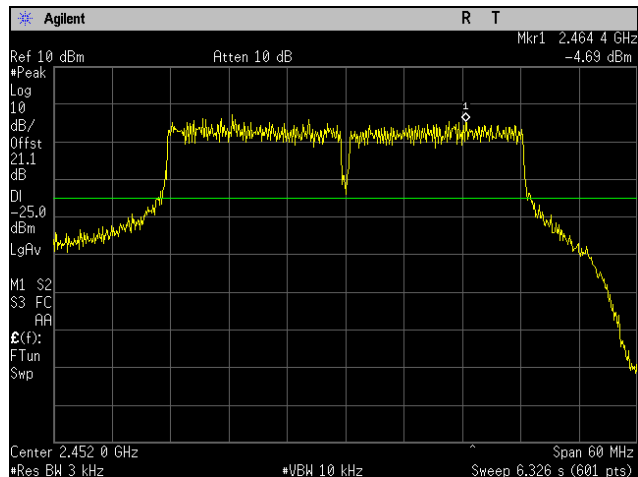

Plot 142. Peak Power Spectral Density, High Channel, 802.11n 40 MHz, Port 1

Peak Power Spectral Density Test Results, 802.11b 20 MHz, Port 2

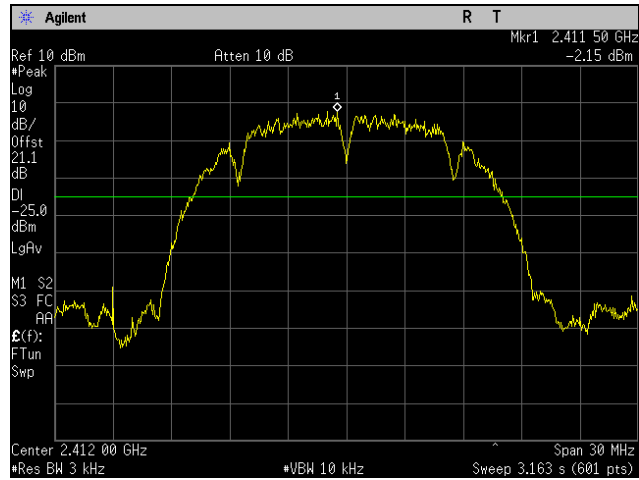

Plot 143. Peak Power Spectral Density, Low Channel, 802.11b 20 MHz, Port 2

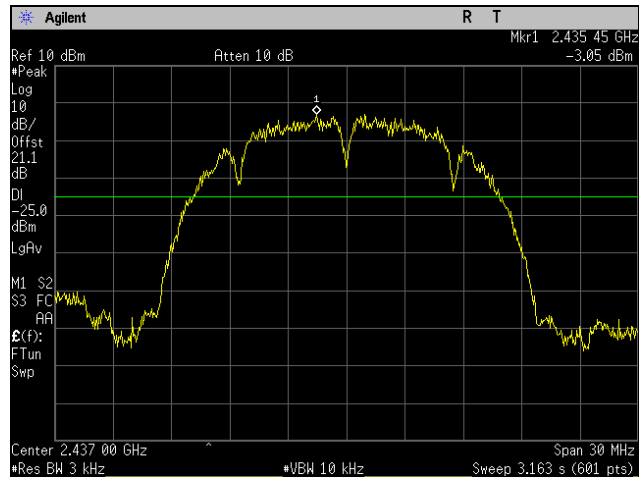

Plot 144. Peak Power Spectral Density, Mid Channel, 802.11b 20 MHz, Port 2

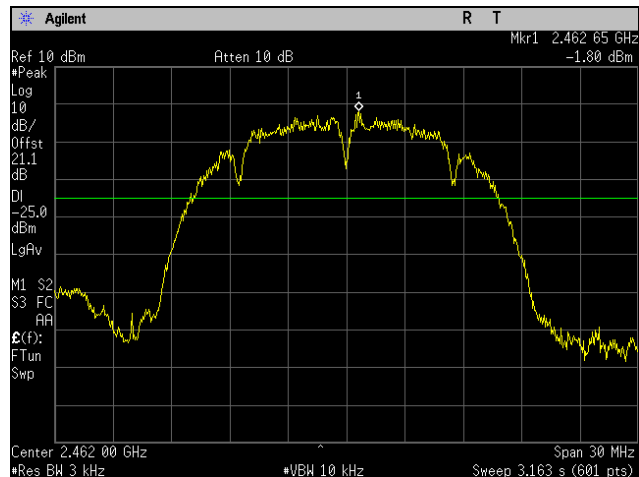

Plot 145. Peak Power Spectral Density, High Channel, 802.11b 20 MHz, Port 2

Peak Power Spectral Density Test Results, 802.11g 20 MHz, Port 2

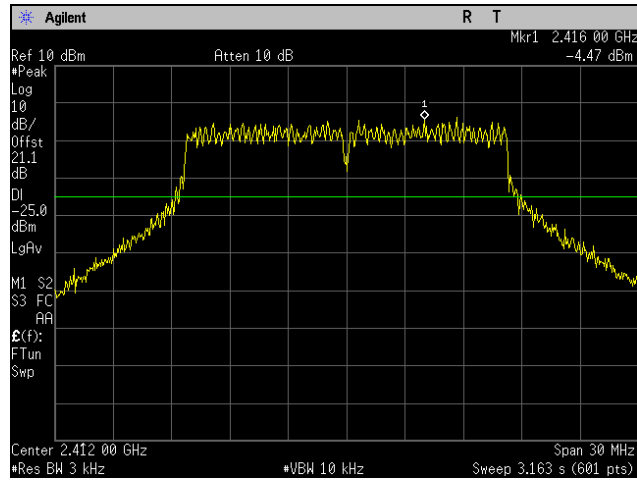

Plot 146. Peak Power Spectral Density, Low Channel, 802.11g 20 MHz, Port 2

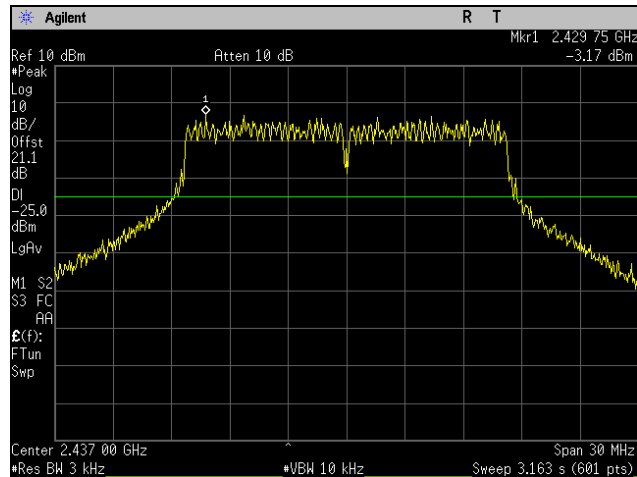

Plot 147. Peak Power Spectral Density, Mid Channel, 802.11g 20 MHz, Port 2

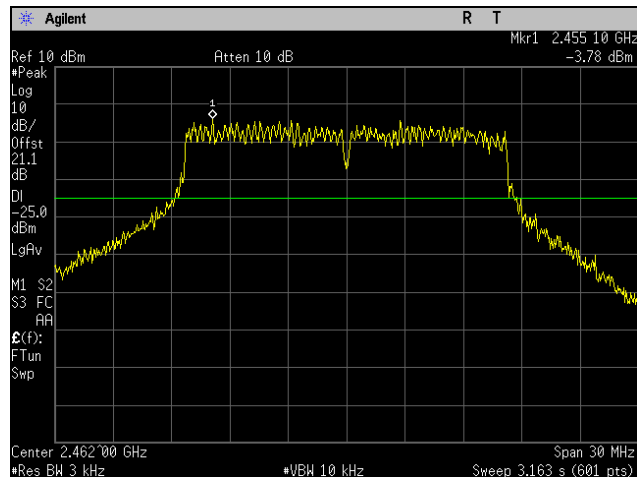

Plot 148. Peak Power Spectral Density, High Channel, 802.11g 20 MHz, Port 2

Peak Power Spectral Density Test Results, 802.11n 20 MHz, Port 2

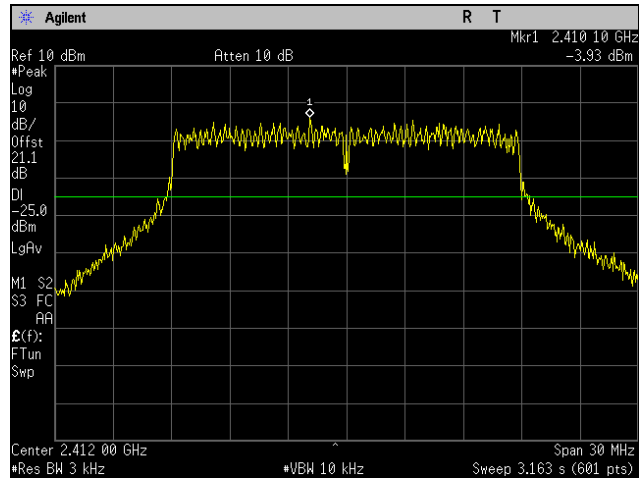

Plot 149. Peak Power Spectral Density, Low Channel, 802.11n 20 MHz, Port 2

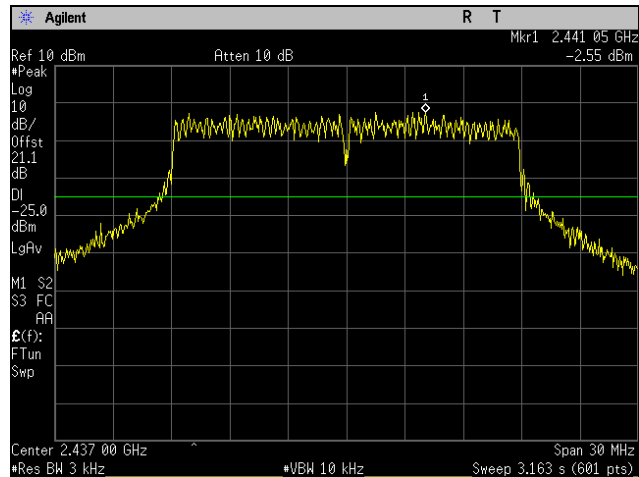

Plot 150. Peak Power Spectral Density, Mid Channel, 802.11n 20 MHz, Port 2

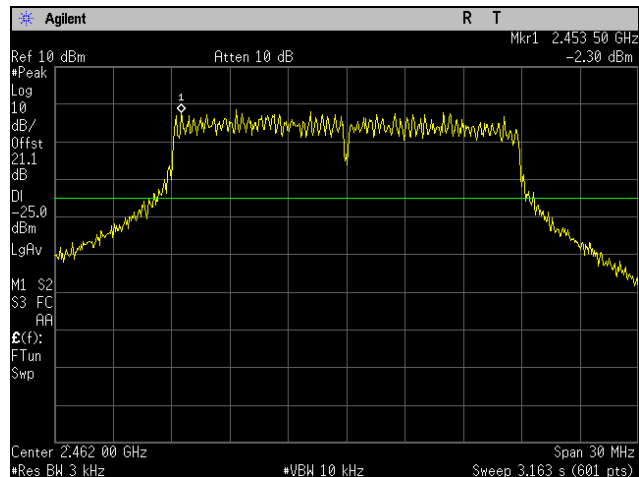

Plot 151. Peak Power Spectral Density, High Channel, 802.11n 20 MHz, Port 2

Peak Power Spectral Density Test Results, 802.11n 40 MHz, Port 2

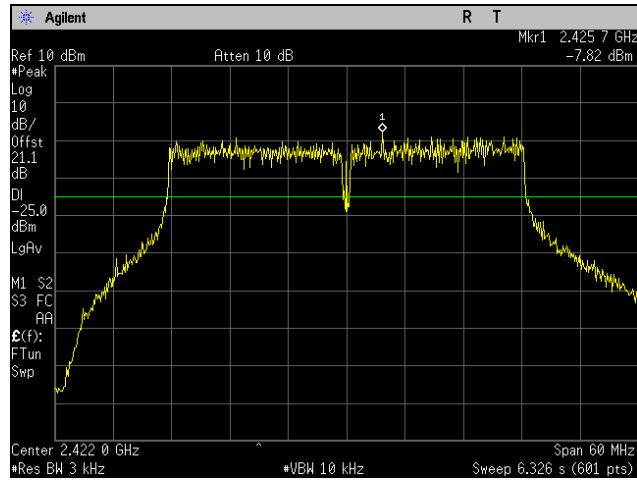

Plot 152. Peak Power Spectral Density, Low Channel, 802.11n 40 MHz, Port 2

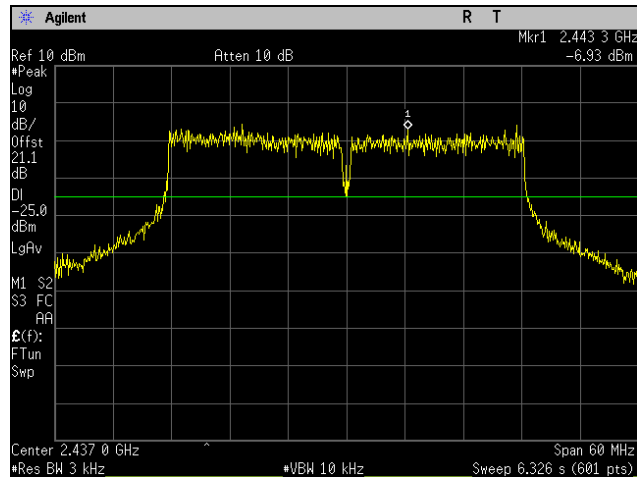

Plot 153. Peak Power Spectral Density, Mid Channel, 802.11n 40 MHz, Port 2

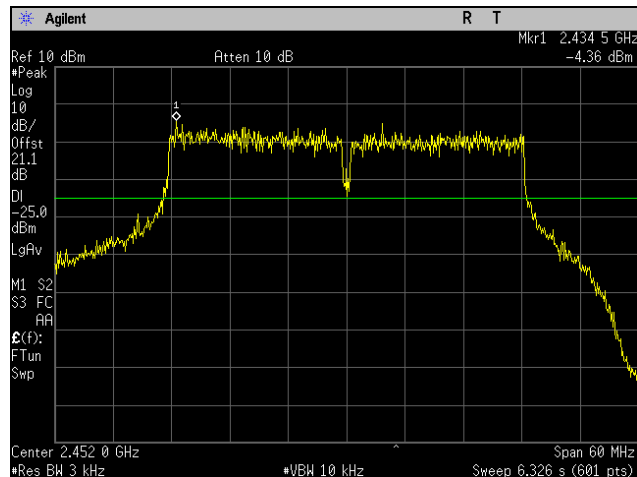

Plot 154. Peak Power Spectral Density, High Channel, 802.11n 40 MHz, Port 2

Peak Power Spectral Density Test Results, 802.11b 20 MHz, Port 3

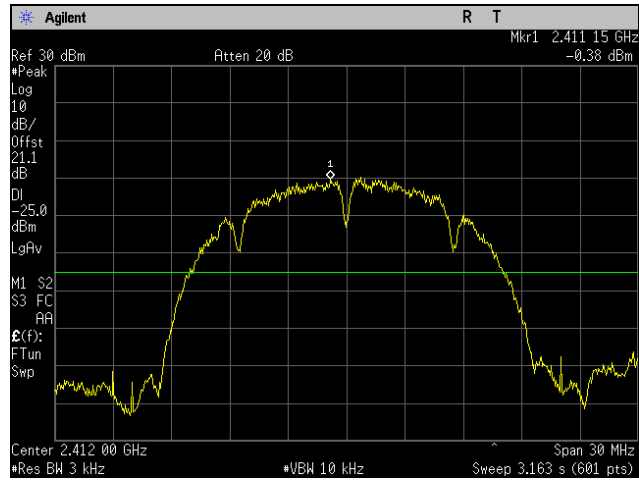

Plot 155. Peak Power Spectral Density, Low Channel, 802.11b 20 MHz, Port 3

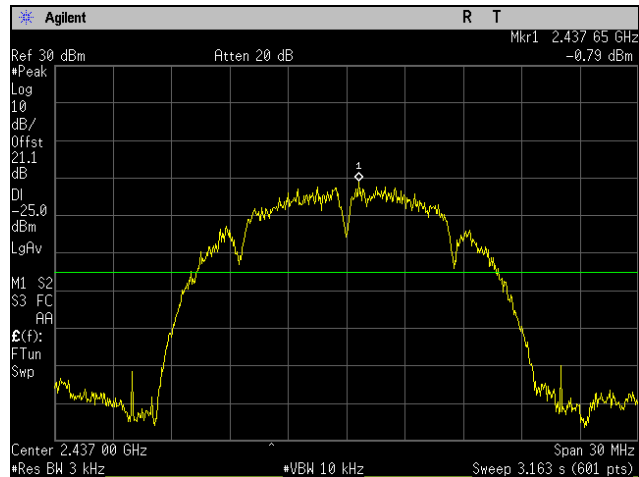

Plot 156. Peak Power Spectral Density, Mid Channel, 802.11b 20 MHz, Port 3

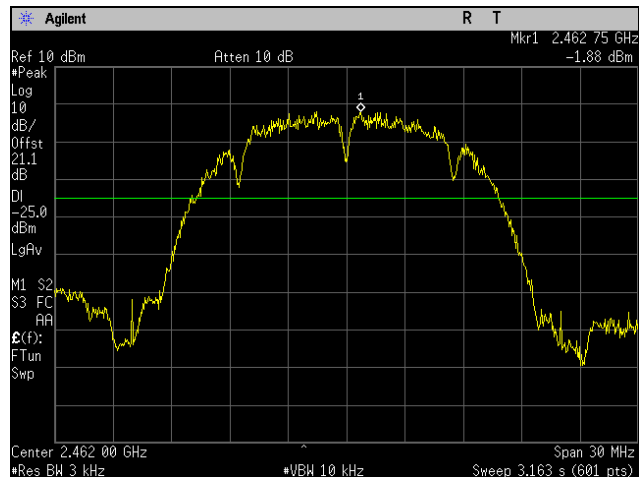

Plot 157. Peak Power Spectral Density, High Channel, 802.11b 20 MHz, Port 3

Peak Power Spectral Density Test Results, 802.11g 20 MHz, Port 3

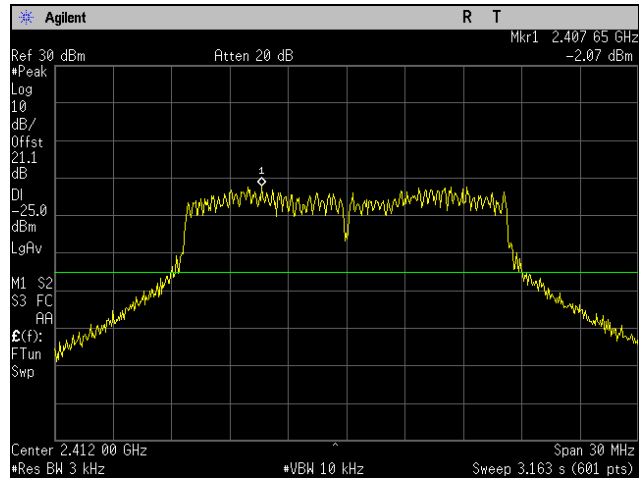

Plot 158. Peak Power Spectral Density, Low Channel, 802.11g 20 MHz, Port 3

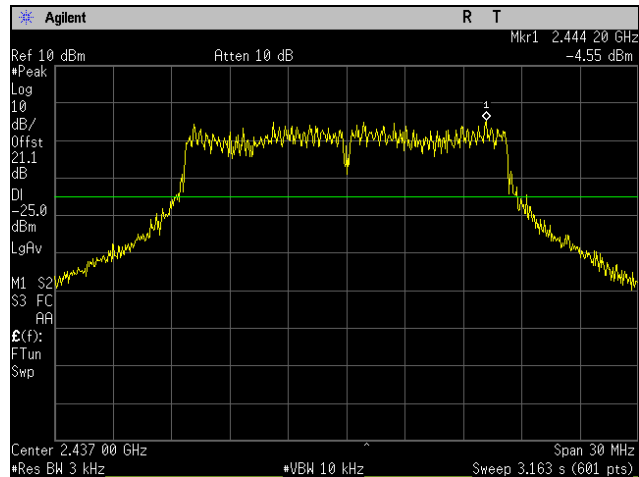

Plot 159. Peak Power Spectral Density, Mid Channel, 802.11g 20 MHz, Port 3

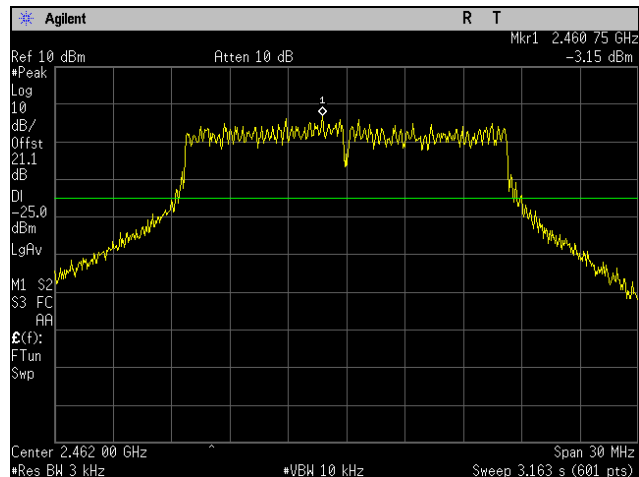

Plot 160. Peak Power Spectral Density, High Channel, 802.11g 20 MHz, Port 3

Peak Power Spectral Density Test Results, 802.11n 20 MHz, Port 3

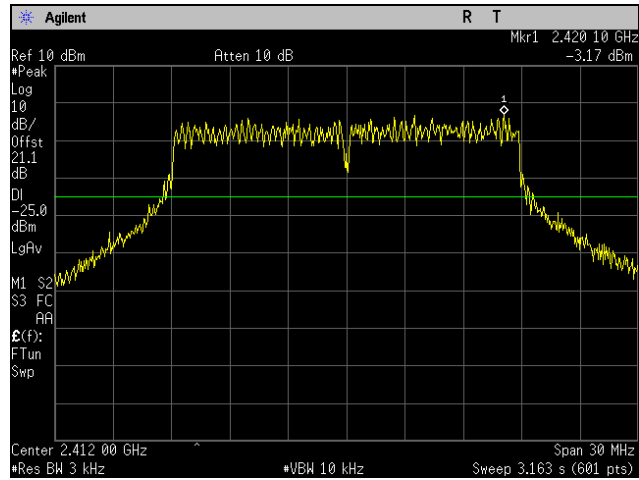

Plot 161. Peak Power Spectral Density, Low Channel, 802.11n 20 MHz, Port 3

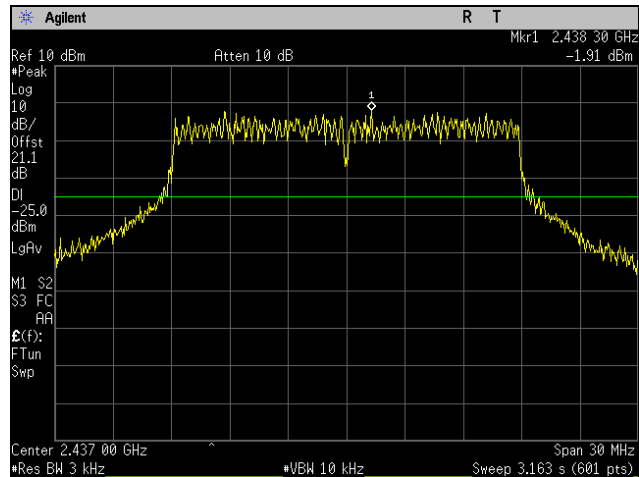

Plot 162. Peak Power Spectral Density, Mid Channel, 802.11n 20 MHz, Port 3

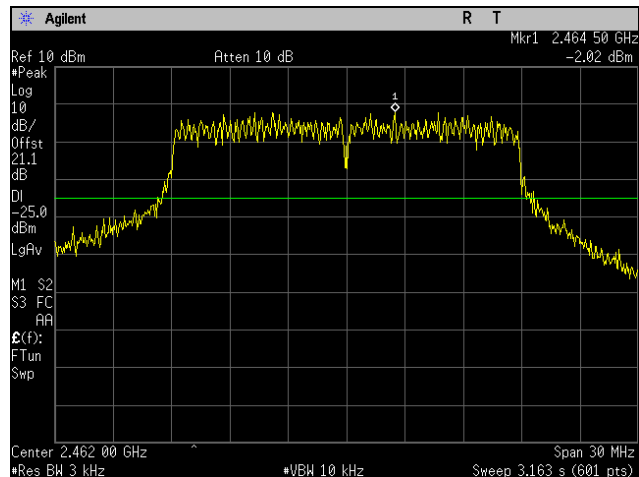

Plot 163. Peak Power Spectral Density, High Channel, 802.11n 20 MHz, Port 3

Peak Power Spectral Density Test Results, 802.11n 40 MHz, Port 3

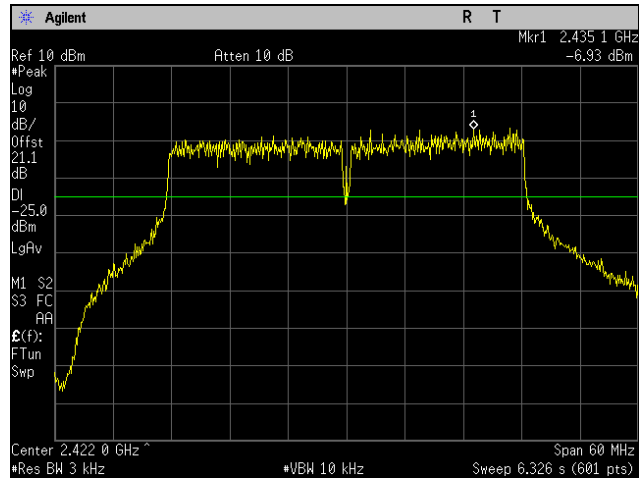

Plot 164. Peak Power Spectral Density, Low Channel, 802.11n 40 MHz, Port 3

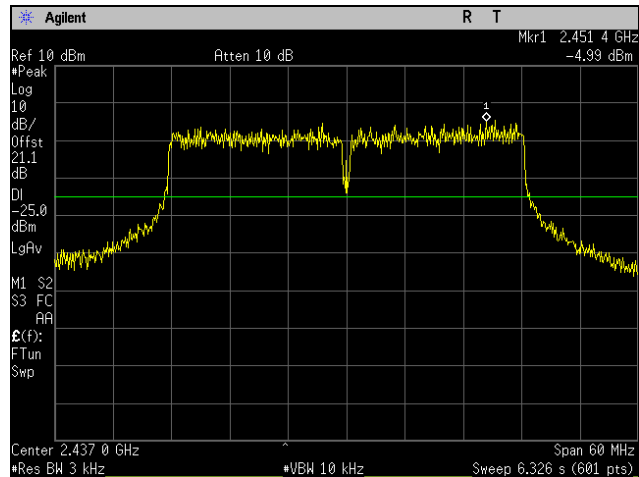

Plot 165. Peak Power Spectral Density, Mid Channel, 802.11n 40 MHz, Port 3

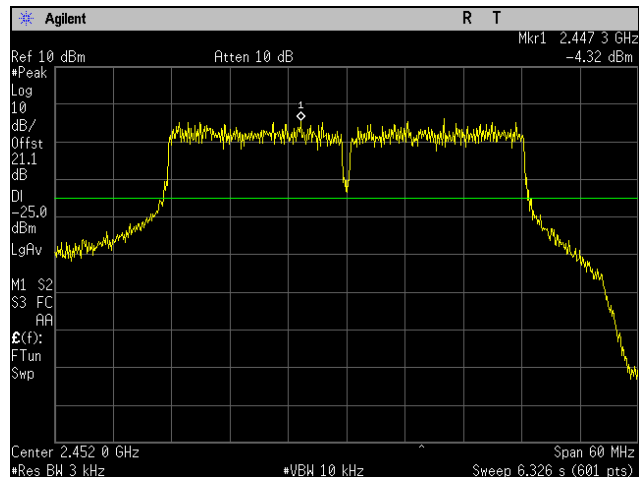

Plot 166. Peak Power Spectral Density, High Channel, 802.11n 40 MHz, Port 3

Peak Power Spectral Density, CDD, Test Results, 802.11n 20 MHz, Port 1

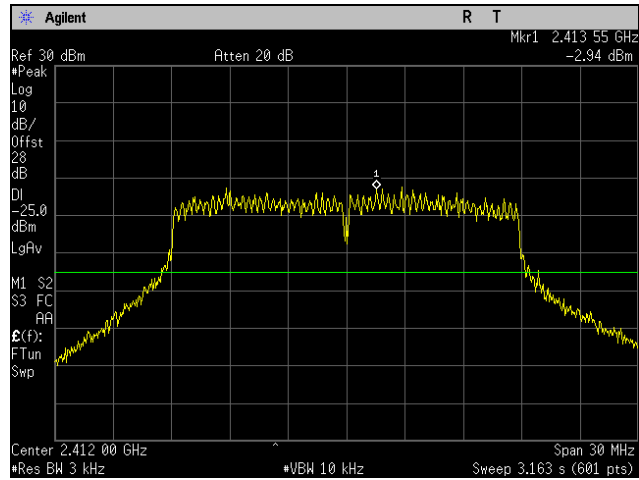

Plot 167. Peak Power Spectral Density, CDD, Low Channel, 802.11n 20 MHz, Port 1

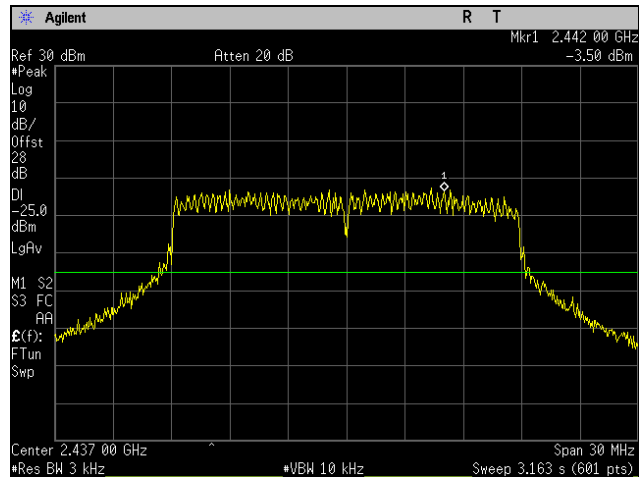

Plot 168. Peak Power Spectral Density, CDD, Mid Channel, 802.11n 20 MHz, Port 1

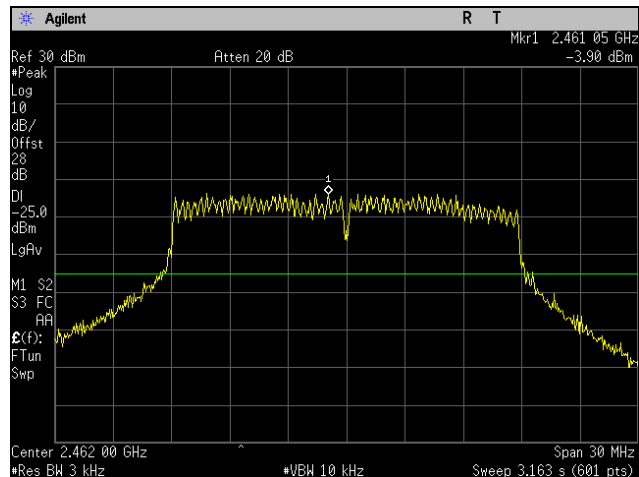

Plot 169. Peak Power Spectral Density, CDD, High Channel, 802.11n 20 MHz, Port 1

Peak Power Spectral Density, CDD, Test Results, 802.11n 40 MHz, Port 1

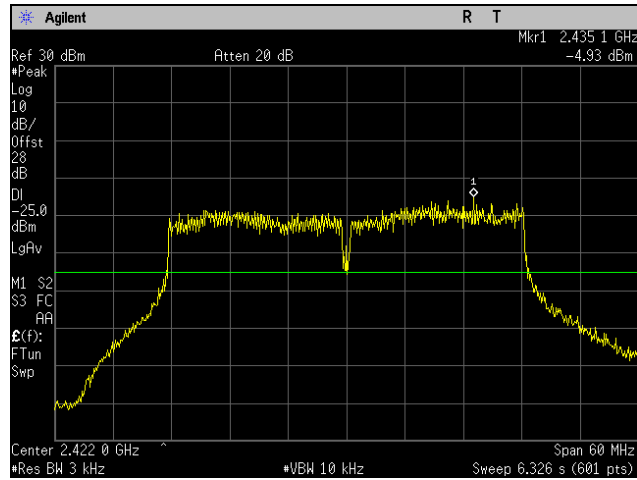

Plot 170. Peak Power Spectral Density, CDD, Low Channel, 802.11n 40 MHz, Port 1

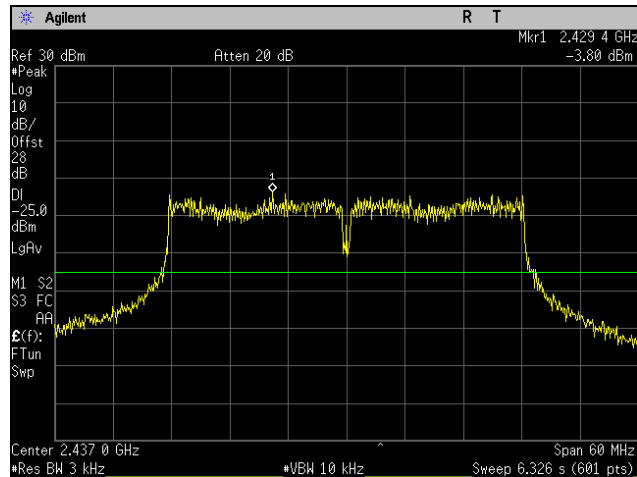

Plot 171. Peak Power Spectral Density, CDD, Mid Channel, 802.11n 40 MHz, Port 1

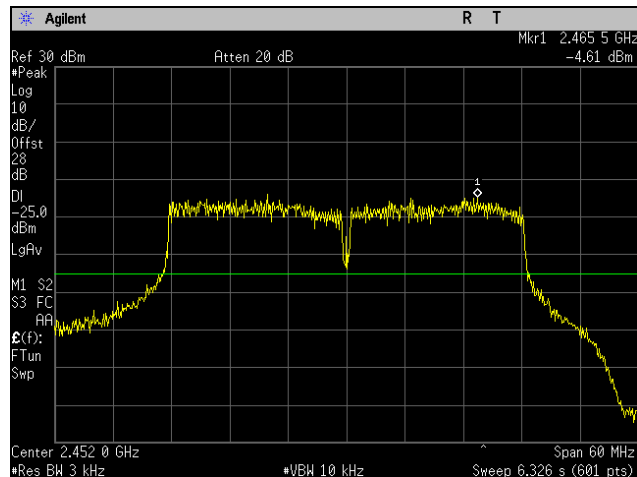

Plot 172. Peak Power Spectral Density, CDD, High Channel, 802.11n 40 MHz, Port 1

Peak Power Spectral Density, CDD, Test Results, 802.11n 20 MHz, Port 2

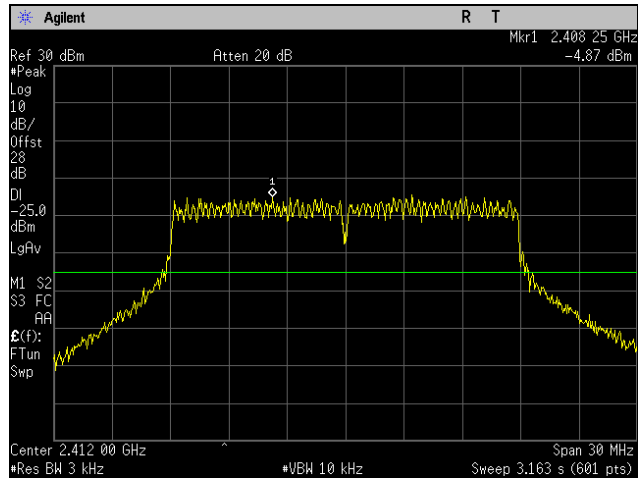

Plot 173. Peak Power Spectral Density, CDD, Low Channel, 802.11n 20 MHz, Port 2

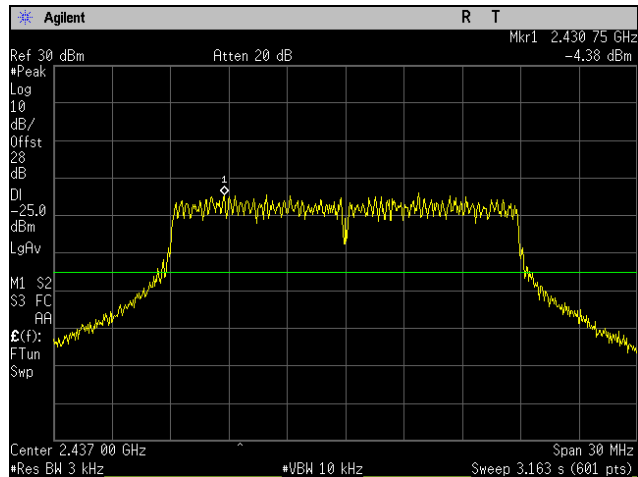

Plot 174. Peak Power Spectral Density, CDD, Mid Channel, 802.11n 20 MHz, Port 2

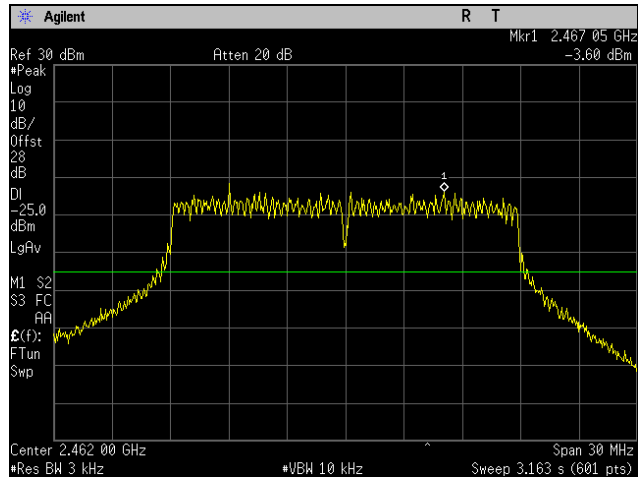

Plot 175. Peak Power Spectral Density, CDD, High Channel, 802.11n 20 MHz, Port 2

Peak Power Spectral Density, CDD, Test Results, 802.11n 40 MHz, Port 2

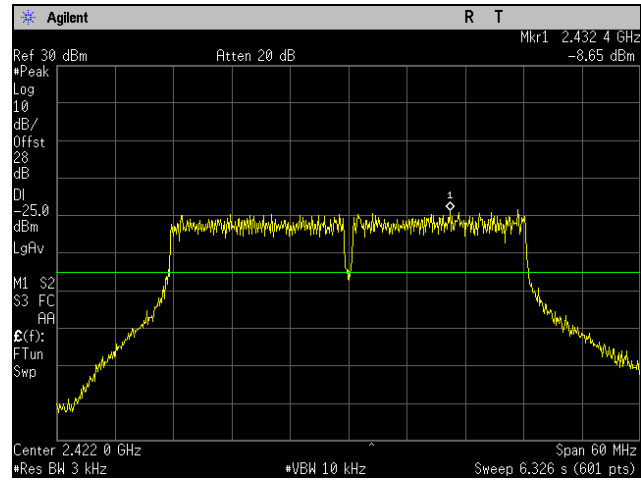

Plot 176. Peak Power Spectral Density, CDD, Low Channel, 802.11n 40 MHz, Port 2

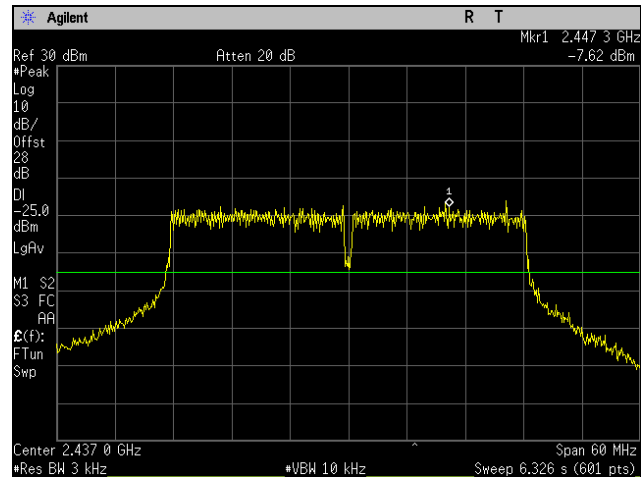

Plot 177. Peak Power Spectral Density, CDD, Mid Channel, 802.11n 40 MHz, Port 2

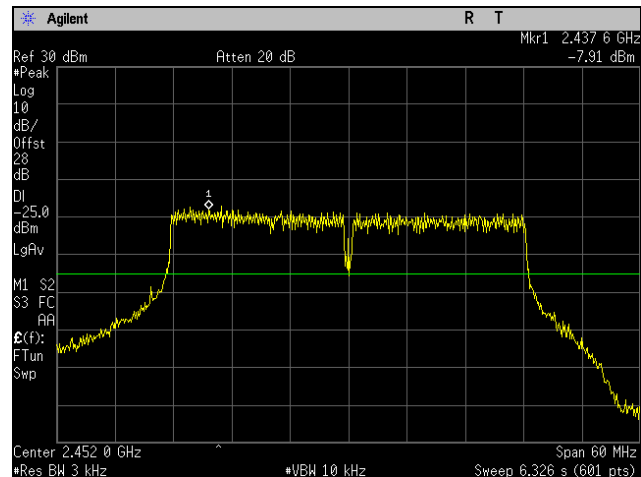

Plot 178. Peak Power Spectral Density, CDD, High Channel, 802.11n 40 MHz, Port 2

Peak Power Spectral Density, CDD, Test Results, 802.11n 20 MHz, Port 3

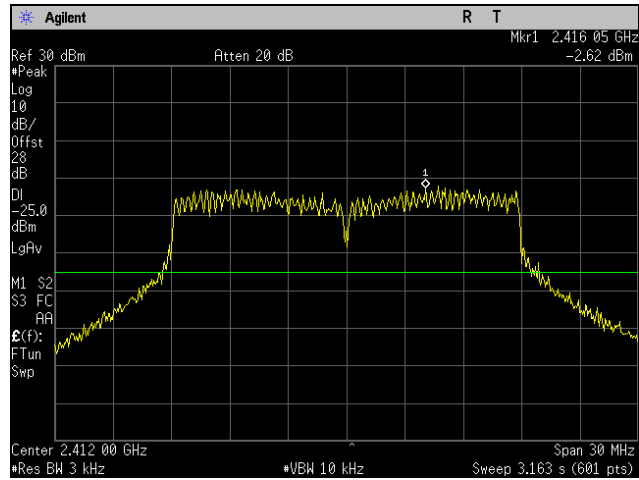

Plot 179. Peak Power Spectral Density, CDD, Low Channel, 802.11n 20 MHz, Port 3

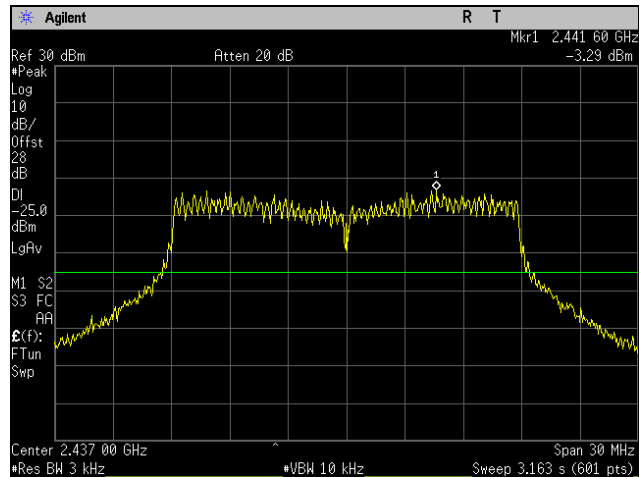

Plot 180. Peak Power Spectral Density, CDD, Mid Channel, 802.11n 20 MHz, Port 3

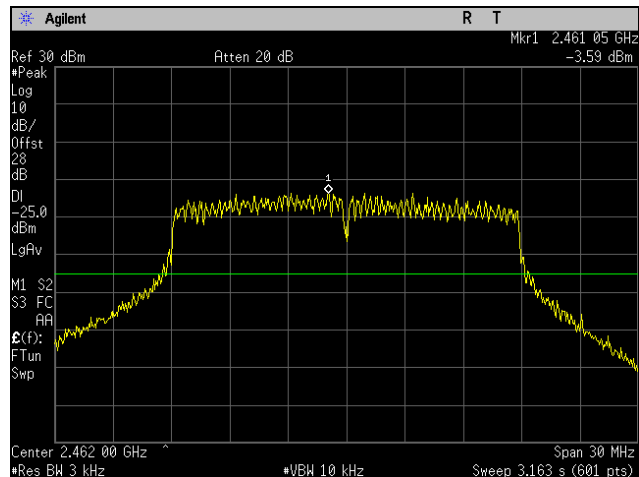

Plot 181. Peak Power Spectral Density, CDD, High Channel, 802.11n 20 MHz, Port 3

Peak Power Spectral Density, CDD, Test Results, 802.11n 40 MHz, Port 3

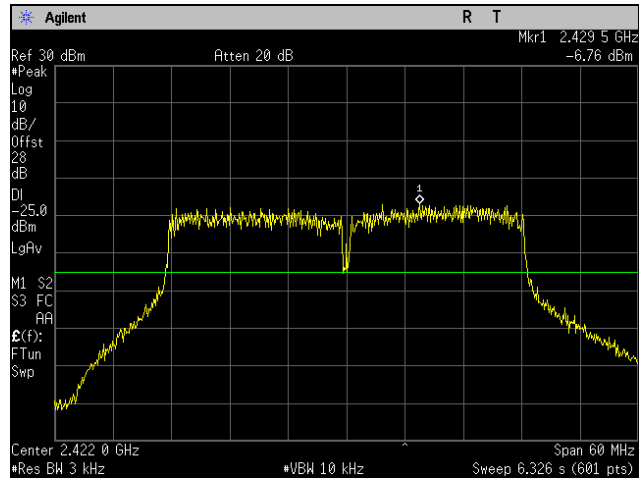

Plot 182. Peak Power Spectral Density, CDD, Low Channel, 802.11n 40 MHz, Port 3

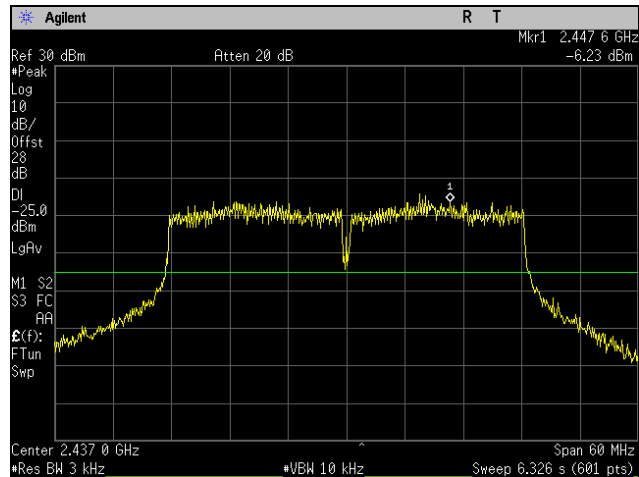

Plot 183. Peak Power Spectral Density, CDD, Mid Channel, 802.11n 40 MHz, Port 3

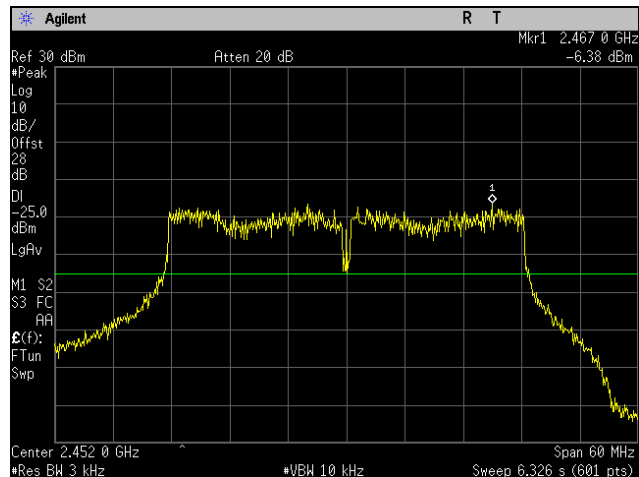

Plot 184. Peak Power Spectral Density, CDD, High Channel, 802.11n 40 MHz, Port 3

Electromagnetic Compatibility Criteria for Intentional Radiators

§ 15.247(i) Maximum Permissible Exposure

RF Exposure Requirements: §1.1307(b)(1) and §1.1307(b)(2): Systems operating under the provisions of this section shall be operated in a manner that ensures that the public is not exposed to radio frequency energy levels in excess of the Commission's guidelines.

RF Radiation Exposure Limit: §1.1310: As specified in this section, the Maximum Permissible Exposure (MPE) Limit shall be used to evaluate the environmental impact of human exposure to radiofrequency (RF) radiation as specified in Sec. 1.1307(b), except in the case of portable devices which shall be evaluated according to the provisions of Sec. 2.1093 of this chapter.

MPE Limit: EUT's operating frequencies @ 2400-2483.5 MHz; **Limit for Uncontrolled exposure: 1 mW/cm² or 10 W/m²**

Equation from page 18 of OET 65, Edition 97-01

$$S = PG / 4\pi R^2 \quad \text{or} \quad R = \sqrt{PG / 4\pi S}$$

where, S = Power Density (mW/cm²)
P = Power Input to antenna (mW)
G = Antenna Gain (numeric value)
R = Distance (cm)

Test Results:

Frequency (MHz)	Con. Pwr. (dBm)	Con. Pwr. (mW)	Ant. Gain (dBi)	Ant. Gain numeric	Pwr. Density (mW/cm ²)	Limit (mW/cm ²)	Margin	Distance (cm)	Result
2412	28.97	788.86	8.64	7.311	1	1	0	21.424	Pass

The safe distance where Power Density is less than the MPE Limit listed above was found to be 21.42 cm.

IV. Test Equipment

Test Equipment

Calibrated test equipment utilized during testing was maintained in a current state of calibration per the requirements of ISO/IEC 17025:2005.

MET Asset #	Equipment	Manufacturer	Model	Last Cal Date	Cal Due Date
1T4751	ANTENNA - BILOG	SUNOL SCIENCES	JB6	2/26/2016	8/26/2017
1T4409	EMI RECEIVER	ROHDE & SCHWARZ	ESIB7	10/29/2014	10/29/2016
1T4818	COMB GENERATOR	COM-POWER	CGO-520	SEE NOTE	
1T4483	ANTENNA; HORN	ETS-LINDGREN	3117	10/8/2015	4/8/2017
1T4442	PRE-AMPLIFIER, MICROWAVE	MITEQ	AFS42-01001800-30-10P	SEE NOTE	
1T6658	SPECTRUM ANALYZER	AGILENT TECHNOLOGIES	E4407B	12/9/2015	12/9/2016
1T4745	ANTENNA, HORN	ETS-LINDGREN	3116	6/27/2015	12/27/2016
1T4752	PRE-AMPLIFIER	MITEQ	JS44-18004000-35-8P	SEE NOTE	
1T4300A	SEMI-ANECHOIC CHAMBER # 1 (FCC)	EMC TEST SYSTEMS	NONE	1/31/2014	01/31/2017
1T4504	SHIELDED ROOM	UNIVERSAL SHIELDING CORP	N/A	NOT REQUIRED	
1T4563	LISN (10 AMP)	SOLAR ELECTRONICS COMPANY	9322-50-R-10-BNC	8/27/2015	2/27/2017

Table 19. Test Equipment List

Note: Functionally tested equipment is verified using calibrated instrumentation at the time of testing.

V. Certification & User's Manual Information

Certification & User's Manual Information

A. Certification Information

The following is extracted from Title 47 of the Code of Federal Regulations, Part 2, Subpart I — Marketing of Radio frequency devices:

§ 2.801 Radio-frequency device defined.

As used in this part, a radio-frequency device is any device which in its operation is capable of Emitting radio-frequency energy by radiation, conduction, or other means. Radio- frequency devices include, but are not limited to:

- (a) The various types of radio communication transmitting devices described throughout this chapter.
- (b) *The incidental, unintentional and intentional radiators defined in Part 15 of this chapter.*
- (c) The industrial, scientific, and medical equipment described in Part 18 of this chapter.
- (d) Any part or component thereof which in use emits radio-frequency energy by radiation, conduction, or other means.

§ 2.803 Marketing of radio frequency devices prior to equipment authorization.

- (a) Except as provided elsewhere in this chapter, no person shall sell or lease, or offer for sale or lease (including advertising for sale or lease), or import, ship or distribute for the purpose of selling or leasing or offering for sale or lease, any radio frequency device unless:
 - (1) In the case of a device subject to certification, such device has been authorized by the Commission in accordance with the rules in this chapter and is properly identified and labeled as required by §2.925 and other relevant sections in this chapter; or
 - (2) In the case of a device that is not required to have a grant of equipment authorization issued by the Commission, but which must comply with the specified technical standards prior to use, such device also complies with all applicable administrative (including verification of the equipment or authorization under a Declaration of Conformity, where required), technical, labeling and identification requirements specified in this chapter.
- (d) Notwithstanding the provisions of paragraph (a) of this section, the offer for sale solely to business, commercial, industrial, scientific or medical users (but not an offer for sale to other parties or to end users located in a residential environment) of a radio frequency device that is in the conceptual, developmental, design or pre-production stage is permitted prior to equipment authorization or, for devices not subject to the equipment authorization requirements, prior to a determination of compliance with the applicable technical requirements *provided* that the prospective buyer is advised in writing at the time of the offer for sale that the equipment is subject to the FCC rules and that the equipment will comply with the appropriate rules before delivery to the buyer or to centers of distribution.

- (e)(1) Notwithstanding the provisions of paragraph (a) of this section, prior to equipment authorization or determination of compliance with the applicable technical requirements any radio frequency device may be operated, but not marketed, for the following purposes and under the following conditions:
- (i) *Compliance testing*;
 - (ii) Demonstrations at a trade show provided the notice contained in paragraph (c) of this section is displayed in a conspicuous location on, or immediately adjacent to, the device;
 - (iii) Demonstrations at an exhibition conducted at a business, commercial, industrial, scientific or medical location, but excluding locations in a residential environment, provided the notice contained in paragraphs (c) or (d) of this section, as appropriate, is displayed in a conspicuous location on, or immediately adjacent to, the device;
 - (iv) Evaluation of product performance and determination of customer acceptability, provided such operation takes place at the manufacturer's facilities during developmental, design or pre-production states; or
 - (v) Evaluation of product performance and determination of customer acceptability where customer acceptability of a radio frequency device cannot be determined at the manufacturer's facilities because of size or unique capability of the device, provided the device is operated at a business, commercial, industrial, scientific or medical user's site, but not at a residential site, during the development, design or pre-production stages.
- (e)(2) For the purpose of paragraphs (e)(1)(iv) and (e)(1)(v) of this section, the term *manufacturer's facilities* includes the facilities of the party responsible for compliance with the regulations and the manufacturer's premises, as well as the facilities of other entities working under the authorization of the responsible party in connection with the development and manufacture, but not the marketing, of the equipment.
- (f) For radio frequency devices subject to verification and sold solely to business, commercial, industrial, scientific and medical users (excluding products sold to other parties or for operation in a residential environment), parties responsible for verification of the devices shall have the option of ensuring compliance with the applicable technical specifications of this chapter at each end user's location after installation, provided that the purchase or lease agreement includes a proviso that such a determination of compliance be made and is the responsibility of the party responsible for verification of the equipment.

Certification & User's Manual Information

The following is extracted from Title 47 of the Code of Federal Regulations, Part 2, Subpart J — Equipment Authorization Procedures:

§ 2.901 Basis and Purpose

- (a) In order to carry out its responsibilities under the Communications Act and the various treaties and international regulations, and in order to promote efficient use of the radio spectrum, the Commission has developed technical standards for radio frequency equipment and parts or components thereof. The technical standards applicable to individual types of equipment are found in that part of the rules governing the service wherein the equipment is to be operated.¹ *In addition to the technical standards provided, the rules governing the service may require that such equipment be verified by the manufacturer or importer, be authorized under a Declaration of Conformity, or receive an equipment authorization from the Commission by one of the following procedures: certification or registration.*
- (b) The following sections describe the verification procedure, the procedure for a Declaration of Conformity, and the procedures to be followed in obtaining certification from the Commission and the conditions attendant to such a grant.

§ 2.907 Certification.

- (a) Certification is an equipment authorization issued by the Commission, based on representation and test data submitted by the applicant.
- (b) Certification attaches to all units subsequently marketed by the grantee which are identical (see Section 2.908) to the sample tested except for permissive changes or other variations authorized by the Commission pursuant to Section 2.1043.

¹ In this case, the equipment is subject to the rules of Part 15. More specifically, the equipment falls under Subpart B (of Part 15), which deals with unintentional radiators.

Certification & User's Manual Information

§ 2.948 Description of measurement facilities.

- (a) Each party making measurements of equipment that is subject to an equipment authorization under Part 15 or Part 18 of this chapter, regardless of whether the measurements are filed with the Commission or kept on file by the party responsible for compliance of equipment marketed within the U.S. or its possessions, shall compile a description of the measurement facilities employed.
- (1) If the measured equipment is subject to the verification procedure, the description of the measurement facilities shall be retained by the party responsible for verification of the equipment.
- (i) *If the equipment is verified through measurements performed by an independent laboratory, it is acceptable for the party responsible for verification of the equipment to rely upon the description of the measurement facilities retained by or placed on file with the Commission by that laboratory. In this situation, the party responsible for the verification of the equipment is not required to retain a duplicate copy of the description of the measurement facilities.*
- (ii) If the equipment is verified based on measurements performed at the installation site of the equipment, no specific site calibration data is required. It is acceptable to retain the description of the measurement facilities at the site at which the measurements were performed.
- (2) If the equipment is to be authorized by the Commission under the certification procedure, the description of the measurement facilities shall be filed with the Commission's Laboratory in Columbia, Maryland. The data describing the measurement facilities need only be filed once but must be updated as changes are made to the measurement facilities or as otherwise described in this section. At least every three years, the organization responsible for filing the data with the Commission shall certify that the data on file is current.

Certification & User's Manual Information

1. Label and User's Manual Information

The following is extracted from Title 47 of the Code of Federal Regulations, Part 15, Subpart A — General:

§ 15.19 Labeling requirements.

(a) *In addition to the requirements in Part 2 of this chapter, a device subject to certification or verification shall be labeled as follows:*

- (1) Receivers associated with the operation of a licensed radio service, e.g., FM broadcast under Part 73 of this chapter, land mobile operation under Part 90, etc., shall bear the following statement in a conspicuous location on the device:

This device complies with Part 15 of the FCC Rules. Operation is subject to the condition that this device does not cause harmful interference.

- (2) A stand-alone cable input selector switch, shall bear the following statement in a conspicuous location on the device:

This device is verified to comply with Part 15 of the FCC Rules for use with cable television service.

- (3) All other devices shall bear the following statement in a conspicuous location on the device:

This device complies with Part 15 of the FCC Rules. Operation is subject to the following two conditions: (1) This device may not cause harmful interference, and (2) this device must accept any interference received, including interference that may cause undesired operation.

- (4) Where a device is constructed in two or more sections connected by wires and marketed together, the statement specified under paragraph (a) of this section is required to be affixed only to the main control unit.

- (5) When the device is so small or for such use that it is not practicable to place the statement specified under paragraph (a) of this section on it, the information required by this paragraph shall be placed in a prominent location in the instruction manual or pamphlet supplied to the user or, alternatively, shall be placed on the container in which the device is marketed. However, the FCC identifier or the unique identifier, as appropriate, must be displayed on the device.

§ 15.21 Information to user.

The user's manual or instruction manual for an intentional or unintentional radiator shall caution the user that changes or modifications not expressly approved by the party responsible for compliance could void the user's authority to operate the equipment.

Verification & User's Manual Information

The following is extracted from Title 47 of the Code of Federal Regulations, Part 15, Subpart B — Unintentional Radiators:

§ 15.105 Information to the user.

- (a) For a Class A digital device or peripheral, the instructions furnished the user shall include the following or similar statement, placed in a prominent location in the text of the manual:

Note: This equipment has been tested and found to comply with the limits for a Class A digital device, pursuant to Part 15 of the FCC Rules. These limits are designed to provide reasonable protection against harmful interference when the equipment is operated in a commercial environment. This equipment generates, uses, and can radiate radio frequency energy and, if not installed and used in accordance with the instruction manual, may cause harmful interference to radio communications. Operation of this equipment in a residential area is likely to cause harmful interference in which case the user will be required to correct the interference at own expense.

- (b) For a Class B digital device or peripheral, the instructions furnished the user shall include the following or similar statement, placed in a prominent location in the text of the manual:

Note: This equipment has been tested and found to comply with the limits for a Class B digital device, pursuant to Part 15 of the FCC Rules. These limits are designed to provide reasonable protection against harmful interference when the equipment is operated in a residential environment. This equipment generates, uses, and can radiate radio frequency energy and, if not installed and used in accordance with the instruction manual, may cause harmful interference to radio communications. However, there is no guarantee that interference will not occur in a particular installation. If this equipment does cause harmful interference to radio or television reception, which can be determined by turning the equipment off and on, the user is encouraged to try to correct the interference by one or more of the following measures:

- Reorient or relocate the receiving antenna.
- Increase the separation between the equipment and receiver.
- Connect the equipment into an outlet on a circuit different from that to which the receiver is connected.
- Consult the dealer or an experienced radio/TV technician for help.

End of Report