

VIEW A

Chassis Label 70 x 44 mm

The distance between printing and edge of label is 3 mm (indicated by dotted lines)
 印刷與貼紙離邊間距為 3mm

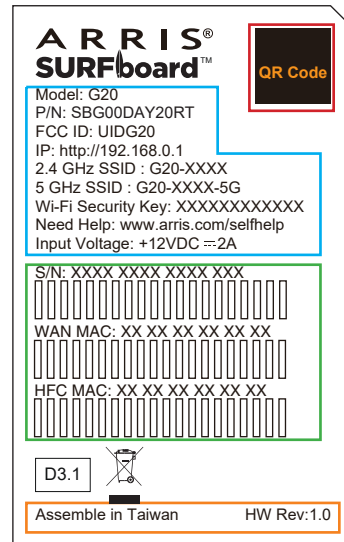
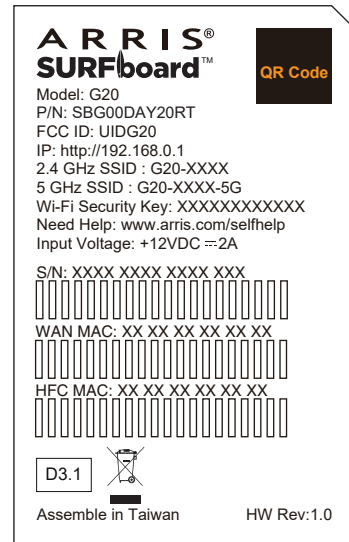

1) General Label items			
Print Type	Label Item	Description	Example
Arial Regular 6pt	Model	Fixed	G20
	P/N	Fixed	SBG00DAY20RT
	FCC ID	Fixed FCC ID	UIDG20
	IP	Fixed IP address	http://192.168.0.1
	2.4 GHz SSID	XXXX: Last four digital of HFC MAC	G20-XXXX
	5 GHz SSID	XXXX: Last four digital of HFC MAC	G20-XXXX-5G
	Wi-Fi Security Key	Manufacturing test program will defined, random, 12-character (base 10 numeric)	XXXXXXXXXXXX
	Need Help	Fixed web address	www.arris.com/selfhelp
	Input Voltage	Fixed voltage indication	+12VDC == 2A

REFER TO SHEET 1 OF THIS PRINT FOR REVISION HISTORY, COPYRIGHT NOTICE AND FULL TITLE BLOCK INFORMATION

DWG NO. F120338674100

REV. 01

SHEET 4 of 11