

Microwave Oven Instructions

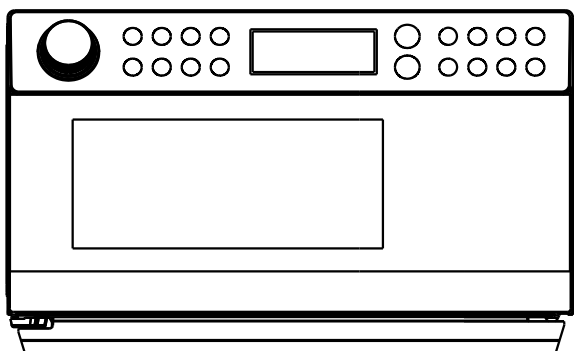

Model: D90D25MSLDV-HG

Please read these instructions carefully before installing and operating the oven.

技术要求：欧盟 ROHS2.0 指令要求规定的 10 种有害物质的含量符合 ROHS2.0 指令要求。

					说明书 DSD259HGH-SAVCOA (D90D25MSLDV-HG)				JS1M0609-23787-004-(0)				
标记	处数	更改单号	签字	日期									
设计	李胜海	标准化	关业红						图样标记	数量	重量	比例	
校对		审定	李丰		S	A	B	1:1	广东格兰仕微波生活 电器制造有限公司				
审核	黄玲												
工艺		日期	2020-08-12	共 16 页	第 / 页								

PRECAUTIONS TO AVOID POSSIBLE EXPOSURE TO EXCESSIVE MICROWAVE ENERGY

1. Do not attempt to operate this oven with the door open since open-door operation can result in harmful exposure to microwave energy. It is important not to defeat or tamper with the safety interlocks.
2. Do not place any object between the oven front face and the door or allow soil or cleaner residue to accumulate on sealing surfaces.
3. Do not operate the oven if it is damaged. It is very important that the oven door close properly and that there is no damage to the
 - a) Door (including any bent),
 - b) Hinges and latches (broken or loosened),
 - c) Door seals and sealing surfaces.
4. The oven should not be adjusted or repaired by anyone except qualified service personnel.

CONTENT

PRECAUTIONS TO AVOID POSSIBLE EXPOSURE TO EXCESSIVE MICROWAVE ENERGY	2
CONTENT	2
IMPORTANT SAFETY INSTRUCTIONS	3
GROUNDING INSTRUCTIONS.....	5
INSTALLATION GUIDE.....	5
COOKING UTENSILS GUIDE	6
SPECIFICATIONS	7
PART NAMES	7
CONTROL PANEL	8
OPERATION INSTRUCTIONS	9
Setting the clock	9
Timer function	9
+30 sec function.....	9
Express cooking.....	9
Microwave cooking	10
Time defrost.....	10
Weight defrost.....	10
Popcorn.....	11
Toast.....	11
Bagel.....	11
Broil.....	11
Bake	12
Pizza.....	12
Potato.....	13
Warm	13
Auto cook	13
Auto reheat	14
Soften/melt.....	15
Child lock	15
Turntable.....	15
Failure diagnose.....	16
CLEANING AND CARE.....	17

IMPORTANT SAFETY INSTRUCTIONS

WARNING!--To reduce the risk of burns, electric shock, fire, injury to persons or exposure to excessive microwave energy:

1. Read all instructions before using the appliance.
2. Read and follow the specific "PRECAUTIONS TO AVOID POSSIBLE EXPOSURE TO EXCESSIVE MICROWAVE ENERGY" on page 1.
3. This appliance must be grounded. Connect only to properly grounded outlet. See "GROUNDING INSTRUCTIONS" on page 4.
4. Install or locate this appliance only in accordance with the provided installation instructions.
5. Do not operate the oven when empty.
6. Some products such as whole eggs and sealed containers -for example, closed glass jars- are able to explode and should not be heated in this oven.
7. Use this appliance only for its intended use as described in this manual. Do not use corrosive chemicals or vapors in this appliance. This type of oven is specifically designed to heat, cook, or dry food. It is not designed for industrial or laboratory use.
8. As with any appliance, close supervision is necessary when used by children.
9. To reduce the risk of fire in the oven cavity:
 - a) Do not overcook food. Carefully attend appliance when paper, plastic, or other combustible materials are placed inside the oven to facilitate cooking.
 - b) Remove wire twist-ties from paper or plastic bags before placing bag in oven.
 - c) If materials inside the oven should ignite, keep oven door closed, turn oven off, and disconnect the power cord or shut off power at the fuse or circuit breaker panel.
 - d) Do not use the cavity for storage purposes. Do not leave paper products, cooking utensils or food in the cavity when not in use.
10. Liquids, such as water, coffee, or tea are able to be overheated beyond the boiling point without appearing to be boiling due to surface tension of the liquid. Visible bubbling or boiling when the container is removed from the microwave oven is not always present. **THIS COULD RESULT IN VERY HOT LIQUIDS SUDDENLY BOILING OVER WHEN A SPOON OR OTHER UTENSIL IS INSERTED INTO THE LIQUID.** To reduce the risk of injury to person:
 - a) Do not overheat the liquid.
 - b) Stir the liquid both before and halfway through heating it.
 - c) Do not use straight-sided containers with narrow necks.
 - d) After heating, allow the container to stand in the microwave oven for a short time before removing the container.
 - e) Use extreme care when inserting a spoon or other utensil into the container.
11. Do not heat oil or fat for deep-frying. It is difficult to control the temperature of oil in microwave oven.
12. Do not cover or block any openings on the appliance.
13. Do not store or use this appliance outdoors. Do not use this product near water, for example, near a kitchen sink, in a wet basement, near a swimming pool, or similar locations.

14. Do not operate this appliance if it has a damaged cord or a plug, if it is not working properly or if it has been damaged or dropped.
15. Do not immerse cord or plug in water. Keep cord away from heated surface. Do not let cord hang over edge of table or counter.
16. This appliance should be serviced only by qualified service personnel, contact nearest authorized service facility for examination, repair, or adjustment.
17. When cleaning surfaces of door and oven that comes together on closing the door, use only mild, nonabrasive soaps, or detergents applied with a sponge or soft cloth.
18. Oversized food or oversized metal utensils should not be inserted in a microwave/toaster oven as they may create a fire or risk of electric shock.
19. Do not clean with metal scouring pads. Pieces can burn off the pad and touch electrical parts involving a risk of electric shock.
20. Do not use paper products when appliance is operated in the toaster mode.
21. Do not store any materials, other than manufacturer's recommended accessories, in this oven when not in use.
22. Do not cover racks or any other part of the oven with metal foil. This will cause overheating of the oven.
23. This equipment has been tested and found to comply with Part 18 of the FCC Rules. Operation is subject to the following two conditions: (1) This device may not cause harmful interference, and (2) this device must accept any interference received, including interference that may cause undesired operation.
CAUTION: Changes or modifications not expressly approved by the party responsible for compliance could void the user's authority to operate the product.
24. This equipment generates, uses and can radiate radio frequency energy and, if not installed and used in accordance with the instructions, may cause harmful interference to radio communications. However, there is no guarantee that interference will not occur in a particular installation. If this equipment does cause harmful interference to radio or television reception, which can be determined by turning the equipment off and on, the user is encouraged to try to correct the interference by one or more of the following measures:
 - Reorient or relocate the receiving antenna.
 - Increase the separation between the equipment and receiver.
 - Connect the equipment into an outlet on a circuit different from that to which the receiver is connected.
 - Consult the dealer or an experienced radio/TV technician for help.

SAVE THESE INSTRUCTIONS

GROUNDING INSTRUCTIONS

This appliance must be grounded. In the event of an electrical short circuit, grounding reduces risk of electric shock by providing an escape wire for the electric current. This appliance is equipped with a cord having a grounding wire with a grounding plug. The plug must be plugged into an outlet that is properly installed and grounded.

WARNING!-- Improper use of the grounding plug can result in a risk of electric shock.

Consult a qualified electrician or serviceman if the grounding instructions are not completely understood, or if doubt exists as to whether the appliance is properly grounded, and if it is necessary to use an extension cord, use only a 3-wire extension cord that has a 3-blade grounding plug and a 3-slot receptacle that will accept the plug on the appliance. The marked rating of the extension cord shall be equal to or greater than the electrical rating of the appliance.

Electrical Requirements

The electrical requirements are a 120 volt 60 Hz, AC only, 20 amp. It is recommended that a separate circuit serving only the oven be provided. The oven is equipped with a 3-prong grounding plug. It must be plugged into a wall outlet properly installed and grounded.

Power Cord

1. A short power supply cord is provided to reduce the risks resulting from becoming entangled in or tripping over a longer cord.
2. Longer cord sets or extension cords are available and may be used if care is exercised in their use.
3. If long cord or extension cord is used:
 - a) The marked electrical rating of the cord set or extension cord should be at least as great as the electrical rating of the appliance.
 - b) The extension cord must be a grounding-type 3-wire cord, and The longer cord should be arranged so that it will not drape over the counter top or table top where it can be pulled on by children or tripped over unintentionally.

INSTALLATION GUIDE

1. Make sure that all the packing materials are removed from the inside of the door.
2. This microwave oven must be placed on a flat.
3. For correct operation, the oven must have sufficient airflow. Allow minimum 20cm of free space necessary above the top surface of the oven and 5cm at both sides. The microwave oven rear plate must be placed close to the wall. Do not cover or block any openings on the appliance. Do not remove feet.
4. The appliance shall be only used on a countertop over 3 feet(914mm) above the floor.
5. Do not operate the oven without glass tray, roller support, and shaft in their proper positions.
6. Make sure that the power cord is undamaged and does not run under the oven or over any hot or sharp surface.
7. The socket must be readily accessible so the microwave oven can be easily unplugged in an emergency.

COOKING UTENSILS GUIDE

This section lists which utensils can be used in this microwave, which have limited use for short periods, and which should not be used in this microwave.

RECOMMENDED

Microwave browning dish — Use to brown the exterior of small items such as steaks, chops, or pancakes. Follow the directions provided with your browning dish.

Microwaveable plastic wrap — Use to retain steam. Leave a small opening for some steam to escape and avoid placing it directly on the food.

Paper towels and napkins — Use for short-term heating and covering; these absorb excess moisture and prevent spattering. Do not use recycled paper towels, which may contain metal and could ignite.

Glass and glass-ceramic bowls and dishes — Use for heating or cooking.

Paper plates and cups — Use for short-term heating at low temperatures. Do not use recycled paper, which may contain metal and could ignite.

Wax paper — Use as a cover to prevent spattering.

Thermometers — Use only those labeled "Microwave Safe" and follow all directions. Check the food in several places. Conventional thermometers may be used on microwave food once the food has been removed from the oven.

LIMITED USE

Aluminum foil — Use narrow strips of foil to prevent overcooking of exposed areas. Using too much foil can damage your oven, so be careful. You should keep distance of 1 inch (2.54cm) between aluminum foil and cavity.

Ceramic, porcelain, and stoneware— Use these if they are labeled "Microwave Safe". If they are not labeled, test them to make sure they can be used safely.

Plastic — Use only if labeled "Microwave Safe". Other plastics can melt.

NOT RECOMMENDED

Glass jars and bottles — Regular glass is too thin to be used in a microwave. It can shatter and cause damage and injury.

Paper bags — These are a fire hazard, except for popcorn bags that are designed for microwave use.

Styrofoam plates and cups — These can melt and leave an unhealthy residue on food.

Plastic storage and food containers — Containers such as margarine tubs can melt in the microwave.

Metal utensils — These can damage your oven. Remove all metal before cooking.

Note:

Should you wish to check if a dish is safe for microwaving, place the empty dish in the oven and microwave on HIGH for 30 seconds. A dish which becomes very hot should not be used.

SPECIFICATIONS

Power Supply	120V/60Hz
Power Consumption (Microwave)	1050W
Power Consumption (Grill)	1500W(Double Grill)
Rated Microwave Power Output	900W
Operation Frequency	2450MHz
Outside Dimensions	11 ⁹ / ₁₆ × 19 ⁵ / ₁₆ × 17 ¹³ / ₁₆ inches
Oven Capacity	0.9 cu.ft.
Net Weight	Approx.24.5lbs

PART NAMES

1. Door Safety Lock System
2. Oven Window
3. Glass Tray
4. Control Panel
5. Wave Guide (Please do not remove the mica plate covering the wave guide)
6. Gasket
7. Top Grill Heater

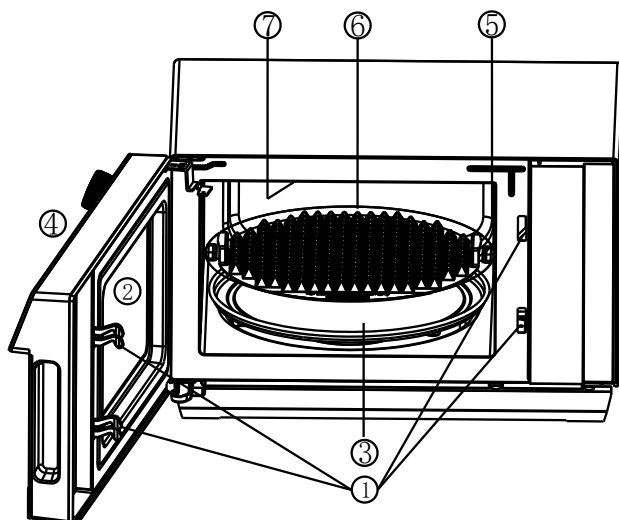

CONTROL PANEL



- **DISPLAY SCREEN**

Cooking time, power, indicators and present time are displayed.

- **TOAST/BAGEL/PIZZA/POPCORN/**

- **POTATO**

Use to cook toast, bagel, pizza, popcorn and potato.

- **BROIL/BAKE**

Use to broil and bake food.

- **CLOCK/TIMER**

Press to set the clock time.

Press to set timer function.

- **WARM**

Use to set keeping warm function.

- **LOCK/TURNTABLE OFF**

Use to set child lock function.

Use to turn turntable on or off.

- **AUTO COOK**

Press to set auto cooking program.

- **AUTO REHEAT**

Press to reheat food.

- **+30 SEC**

Press to add cooking time.

- **MICRO**

Press to set microwave cooking program.

- **DEFROST/TIME/WEIGHT**

Press to defrost food based on time.

Press to defrost food based on weight.

- **SOFTEN/MELT**

Press to cook soft and melt food.

- **STOP/CANCEL**

Press to clear all previous settings before cooking starts.

Press once to stop cooking temporarily or twice to cancel cooking altogether.

- **START**

Press to start cooking or defrosting program.

- **MENU/TIME/WEIGHT (dial)**

Turn to select food menus, enter time, temperature, food weight or servings.

Press to confirm setting or start the oven.

OPERATION INSTRUCTIONS

- When the oven is first plugged in, beep will sound and the display will show "12:00" (":" flashing).
- In the process of setting, broke about 20 seconds the oven will return to standby mode.
- During cooking, if press STOP/CANCEL button once, the program will be paused, then press START button or press MENU/TIME/WEIGHT dial to resume, but if press STOP/CANCEL button twice, the program will be canceled.
- After cooking end, the screen will display End and beep will sound every two minutes until user press STOP/CANCEL button or open the door.
- If there is not any operation for 1 minute, the display will becomes weakly bright, press any button to light the screen.
- During cooking, the display will show "Cooking" and progress bar.

SETTING THE CLOCK

This is a 12- or 24- hour clock. You can choose to set the clock time in 12- or 24- hour cycle by pressing the CLOCK/TIMER button in standby mode.

1. In standby mode, press and hold CLOCK/TIMER button for 3 seconds to select 12- hour clock, press the button again to select 24- hour clock.
2. Turn MENU/TIME/WEIGHT dial until the correct hour is displayed.
3. Press CLOCK/TIMER or START or MENU/TIME/WEIGHT dial once .
4. Turn MENU/TIME/WEIGHT dial until the correct minute is displayed.
5. Press CLOCK/TIMER or START or MENU/TIME/WEIGHT dial once to confirm.

TIMER FUNCTION

You can use the timer feature, when you need to be reminded of the cooking or some other things.

1. In standby mode, press CLOCK/TIMER button once.
2. Turn MENU/TIME/WEIGHT dial to enter desired time. The longest time is 95 minutes.
3. Press MENU/TIME/WEIGHT dial or START button to confirm.

NOTE: When the countdown ends, the buzzer will beep to remind you. You can check the countdown time by pressing CLOCK/TIMER button. But if STOP/CANCEL button is pressed when the display shows the time, the function can be cancelled.

+30 SEC FUNCTION

During cooking, you can add cooking time by pressing +30 SEC button repeatedly. The longest time is 95 minutes.

NOTE: Auto cook menus, time defrost and weight defrost cannot be added cooking time.

EXPRESS COOKING

Use this feature to program the oven to microwave food at 100% power conveniently.

In standby mode, turn MENU/TIME/WEIGHT dial to enter cooking time, and then press the MENU/TIME/WEIGHT dial or START button once. The oven will start working automatically.

MICROWAVE COOKING

1. In standby mode, press MICRO button once.
2. Turn MENU/TIME/WEIGHT dial to select power level.
3. Press MENU/TIME/WEIGHT dial or START button.
4. Turn MENU/TIME/WEIGHT dial to enter cooking time. The longest time is 95 minutes.
5. Press MENU/TIME/WEIGHT dial or START to confirm.

Turn MENU/TIME/WEIGHT dial to enter cooking power level:

Turn MENU/TIME/WEIGHT	Power (Display)	Turn MENU/TIME/WEIGHT	Power (Display)
Once	100% (P100)	7 times	40% (P-40)
Twice	90% (P-90)	8 times	30% (P-30)
3 times	80% (P-80)	9 times	20% (P-20)
4 times	70% (P-70)	10 times	10% (P-10)
5 times	60% (P-60)	11 times	0% (P-00)
6 times	50% (P-50)		

TIME DEFROST

The defrosting power is adjusted automatically once the cooking time is programmed.

1. In standby mode, press DEFROST/TIME/WEIGHT button once.
2. Turn MENU/TIME/WEIGHT dial to enter defrosting time. The longest time is 95 minutes.
3. Press MENU/TIME/WEIGHT dial or START button to confirm.

NOTE: During defrosting program, the system will pause to remind you to turn over the food, after that, press MENU/TIME/WEIGHT dial or START to resume.

WEIGHT DEFROST

The defrosting time and power level are automatically set once the food category and the weight are programmed.

1. In standby mode, press DEFROST/TIME/WEIGHT button twice.
2. Turn MENU/TIME/WEIGHT dial to select a food code (dEF1-Meat, dEF2-Poultry, dEF3-Seafood).
3. Press MENU/TIME/WEIGHT or START once.
4. Turn MENU/TIME/WEIGHT dial to enter the food weight.
5. Press MENU/TIME/WEIGHT dial or START to start.

The allowable weight for each category is shown below:

Food	Display	Weight Range
Meat	dEF1	4 oz - 48 oz
Poultry	dEF2	4 oz - 48 oz
Seafood	dEF3	4 oz - 32 oz

NOTE:

- Weight must be in pounds and ounces. If label gives weight in pounds only, change the fraction of a pound to ounces using the following chart.

Converting fractions of a pound to ounces:

Fractions of a pound	Ounces
Less than .03	0

Fractions of a pound	Ounces
.54 to .59	9

.03 to .09	1
.10 to .15	2
.16 to .21	3
.22 to .27	4
.28 to .34	5
.35 to .40	6
.41 to .46	7
.47 to .53	8

.60 to .65	10
.66 to .71	11
.72 to .78	12
.79 to .84	13
.85 to .90	14
.91 to .97	15
above .97	go to next even

- During defrosting program, the system will pause and sound to remind you to turn over the food, after that, press MENU/TIME/WEIGHT dial START to resume.

POPCORN

1. In standby mode, press POPCORN button once.
2. Turn MENU/TIME/WEIGHT dial to adjust cooking time.
3. Press MENU/TIME/WEIGHT dial or START button once to start.

NOTE: The popcorn weight is 3 oz.

TOAST

1. In standby mode, press TOAST button once.
2. Turn MENU/TIME/WEIGHT dial to select servings (1~4 PC).
3. Press MENU/TIME/WEIGHT dial or START button.
4. Turn MENU/TIME/WEIGHT dial to select the darkness (1-light, 2-moderate, 3- dark).
5. Press MENU/TIME/WEIGHT dial or START button to start.

BAGEL

1. In standby mode, press BAGEL button once.
2. Turn MENU/TIME/WEIGHT dial to select servings (1~4 PC).
3. Press MENU/TIME/WEIGHT dial or START button.
4. Turn MENU/TIME/WEIGHT dial to select the darkness (1-light, 2-moderate, 3- dark).
5. Press MENU/TIME/WEIGHT dial or START button to start.

NOTE: After cooking end, open the oven door, the display will show "END" for 3 minutes and then the oven will return to standby mode. You can add the cooking time by pressing +30 SEC button within the 3 minutes, the longest time is 2 minutes.

BROIL

For food code "Ar-1", "Ar-2" and "Ar-3":

1. In standby mode, press BROIL button twice.
2. Turn MENU/TIME/WEIGHT dial to select a food code.

Code	Food	Weight	Time
Ar-1	Pork Chop	6oz	16:00
		12oz	19:00
		18oz	22:00
		24oz	24:00
Ar-2	Steak	8oz	16:00
		12oz	19:00

		16oz	22:00
Ar-3	Salmon Filet	4oz	11:00
		8oz	14:00
		12oz	17:00
		16oz	20:00
		20oz	23:00

3. Press MENU/TIME/WEIGHT dial or START button once.
4. Turn MENU/TIME/WEIGHT dial to enter the food weight.
5. Press MENU/TIME/WEIGHT dial or START button once to start.

For others food:

1. In standby mode, press BROIL button once.
2. Turn MENU/TIME/WEIGHT dial to select temperature (400°F→425°F→350°F→375°F).
3. Press MENU/TIME/WEIGHT dial or START button once.
4. Turn MENU/TIME/WEIGHT dial to enter cooking time.
5. Press MENU/TIME/WEIGHT dial or START button to start.

BAKE

For food code "Ab-1", "Ab-2" and "Ab-3":

1. In standby mode, press BAKE button twice.
2. Turn MENU/TIME/WEIGHT dial to select food code.

Code	Food	Preheat Time	Cooking Time
Ab-1	Cookies	3:00	11:00
Ab-2	Brownies	10:00	51:00
Ab-3	Cake	6:00	11:00

3. Press MENU/TIME/WEIGHT dial or START button once to start preheat.
4. After preheating end, open the door and place container of food at the center of the turntable.
5. Press MENU/TIME/WEIGHT dial or START button to start.

For others food:

1. In standby mode, press BAKE button once.
2. Turn MENU/TIME/WEIGHT dial to select temperature (350°F→375°F→400°F→325°F).
3. Press MENU/TIME/WEIGHT dial or START button once.
4. Turn MENU/TIME/WEIGHT dial to enter cooking time.
5. Press MENU/TIME/WEIGHT dial or START button once to start preheat.
6. After preheating end, open the door and place container of food at the center of the turntable.
7. Press MENU/TIME/WEIGHT dial or START button once to start.

PIZZA

1. In standby mode, press PIZZA button once.
2. Turn MENU/TIME/WEIGHT dial to select temperature (400°F→425°F→350°F→375°F).
3. Press MENU/TIME/WEIGHT dial or START button once.
4. Turn MENU/TIME/WEIGHT dial to enter cooking time. The longest time is 35 minutes.
5. Press MENU/TIME/WEIGHT dial or START button to start.

NOTE: During cooking, you can press +30 SEC button repeatedly to add cooking time an up to 35 minutes.

POTATO

1. In standby mode, press POTATO button once.
2. Turn MENU/TIME/WEIGHT dial to enter food weight (8-24 oz).
3. Press MENU/TIME/WEIGHT dial or START button to start.

WARM

1. In standby mode, press WARM button once.
2. Turn MENU/TIME/WEIGHT dial to select temperature (160°F, 170°F, 180°F, 190°F, 200°F).
3. Press MENU/TIME/WEIGHT dial or START button once.
4. Turn MENU/TIME/WEIGHT dial to enter cooking time. The longest time is 95 minutes.
5. Press MENU/TIME/WEIGHT dial or START button to start.

NOTE: During cooking, you can press +30 SEC button repeatedly to add cooking time an up to 95 minutes.

AUTO COOK

1. In standby mode, press AUTO COOK button once.
2. Turn MENU/TIME/WEIGHT dial to select a food code.
3. Press MENU/TIME/WEIGHT dial or START once.
4. Turn MENU/TIME/WEIGHT dial to select food weight or servings.
5. Press MENU/TIME/WEIGHT dial or START to start.

Auto cook menus:

Code	Food	Weight
AC-1	Beverage	8 oz
		10 oz
		12 oz
AC-2	Fresh vegetable	8 oz
		12 oz
		16 oz
		20 oz
AC-3	Frozen vegetable	8 oz
		12 oz
		16 oz
		20 oz
AC-4	Frozen pizza	6 inch
		9 inch
		12 inch
AC-5	Oatmeal	1 oz
		1.5 oz
		2 oz
		2.5 oz
		3 oz

AUTO REHEAT

1. In standby mode, press AUTO REHEAT button once.
2. Turn MENU/TIME/WEIGHT dial to select a food code.
3. Press MENU/TIME/WEIGHT dial or START once.
4. Turn MENU/TIME/WEIGHT dial to select food weight or servings.
5. Press MENU/TIME/WEIGHT or START to start.

Auto reheat menus:

Code	Food	Weight
AH-1	Frozen entree	8 oz
		12 oz
		16 oz
		20 oz
		24 oz
AH-2	Dinner plate	8 oz
		12 oz
		16 oz
		20 oz
		24 oz
AH-3	Soup/Sauc	4 oz
		8 oz
		12 oz
		16 oz
		20 oz
		24 oz
AH-4	Chili	4 oz
		8 oz
		12 oz
		16 oz
		20 oz
		24 oz
AH-5	Pasta	4 oz
		8 oz
		12 oz
		16 oz
		20 oz
		24 oz
AH-6	Mac and Cheese	4 oz
		8 oz
		12 oz
		16 oz
		20 oz
		24 oz

AH-7	Mashed Potatoes	4 oz
		8 oz
		12 oz
		16 oz
		20 oz
		24 oz
AH-8	Rice	4 oz
		8 oz
		12 oz
		16 oz
		20 oz
		24 oz
		28 oz

SOFTEN/MELT

1. In standby mode, press SOFTEN/MELT button once or twice to select code "SF-1" or "SF-2".
2. Press MENU/TIME/WEIGHT dial or START button once.
3. Turn MENU/TIME/WEIGHT dial to enter food servings.
4. Press MENU/TIME/WEIGHT dial or START button once to start.

Code	Food	Serving
SF-1	Butter Soften	1 piece
		2 pieces
SF-2	Butter Melt	1 piece
		2 pieces

CHILD LOCK

The child proof lock prevents unsupervised operation by children.

To set the child proof lock: Press and hold LOCK/TURNTABLE OFF button more than 3 seconds, the indicator light will come on. In the lock state, all buttons are disabled.

To cancel the child proof lock: Press and hold LOCK/TURNTABLE OFF button more than 3 seconds, the indicator light will come off.

TURNTABLE

During cooking, the turntable is default working. You can turn the turntable on or off by pressing LOCK/TURNTABLE OFF button.

NOTE: Sometimes the turntable may become too hot to press. Be careful to touch the turntable. When the turntable is set in standby mode, the setting of the turntable will not take effect immediately, but will take effect when cooking is started.

FAILURE DIAGNOSE

Failures	Possible reasons
An error sign "Er10" display.	High temperature alarm.
An error sign "Er11" display.	Low temperature alarm.
An error sign "Er12" display.	Open circuit alarm.
An error sign "Er13" display.	Short circuit alarm.
An error sign "Er30" display.	Inverter failure.
An error sign "Er40" display.	Inverter input under voltage.
An error sign "Er41" display.	Inverter input over voltage.
An error sign "Er42" display.	Over current protection.
An error sign "Er43" display.	Over temperature protection.
An error sign "Er44" display.	Magnetron fault.
An error sign "Er45" display.	Surge protection.
An error sign "Er46" display.	High voltage fault.
An error sign "Er47" display.	Switch tube fault.
An error sign "Er48" display.	Communication fault.
An error sign "Er49" display.	Auxiliary power supply.
An error sign "Er60" display.	Sensor fault, open circuit or short circuit.
An error sign "Er61" display.	Sensors selection is out of range.
An error sign "Er81" display.	Displayer communication transmission fault.
An error sign "Er82" display.	Displayer communication receiving fault.

NOTE: For "Er10 ~ Er13", the display shows the code and continues to beep, after pressing STOP/CANCEL button, the system comes back to normal standby mode.

CLEANING AND CARE

1. Turn off the oven and unplug the power cord from the wall when cleaning.
2. Keep the inside of the oven clean. When food splatters or spilled liquids adhere to oven walls, wipe with a damp cloth. Mild detergents may be used if the oven gets very dirty. Avoid using spray or other harsh cleaners. They may stain, streak or dull the door surface.
3. The outside of the oven should be cleaned with a damp cloth. To prevent damage to the operating parts inside the oven, water should not be allowed to seep into the ventilation openings.
4. Wipe the door and window on both sides, the door seals and adjacent parts frequently with a damp cloth to remove any spills or splatters. Do not use abrasive cleaner.
5. Do not allow the control panel to become wet. Clean with a soft, damp cloth. When cleaning the control panel, leave oven door open to prevent oven from accidentally turning on.
6. If steam accumulates inside or around the outside of the oven door, wipe with a soft cloth. This may occur when the microwave oven is operated under high humidity condition. And it is normal.
7. It is occasionally necessary to remove the glass tray for cleaning. Wash the tray in warm sudsy water or in a dishwasher.
8. The roller ring and oven floor should be cleaned regularly to avoid excessive noise. Simply wipe the bottom surface of the oven with mild detergent. The roller ring may be washed in mild, soapy water or in a dishwasher. When removing the roller ring, be sure to replace it in the proper position.
9. Remove odors from your oven by combining a cup of water with the juice and skin of one lemon in a microwaveable bowl. Microwave for 5 minutes. Wipe thoroughly and dry with a soft cloth.
10. If the light bulb burns out, please contact customer service to have it replaced.
11. The oven should be cleaned regularly and any food deposits should be removed. Failure to maintain the oven in a clean condition could lead to deterioration of surface that could adversely affect the life of the unit and could possibly result in a hazardous situation.
12. Please do not dispose of this appliance into the domestic rubbish bin; it should be disposed to the particular disposal center provided by the municipalities.
13. When the microwave oven with grill function is first used, it may produce slight smoke and smell. This is a normal phenomenon, because the oven is made of a steel plate coated with lubricating oil, and the new oven will produce fumes and odor generated by burning the lubricating oil. This phenomenon will disappear after a period of using.