

Model: SBD208B8H-P0FC0A

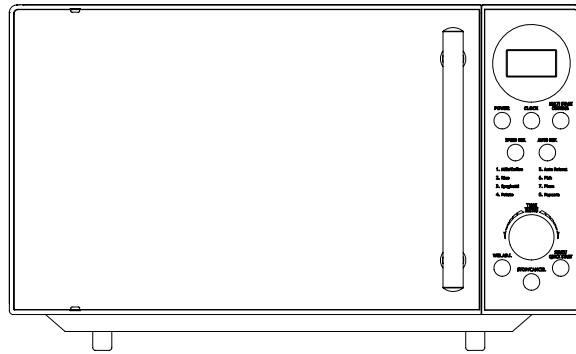

Microwave Oven

User's manual

Please read these instructions carefully before installing and operating the oven.

FCC Warning Statement:

The Device complies with part 18 of the FCC rules, Operation is subject to the following conditions:

- (1) This device may not cause harmful interference,
 - (2) this device must accept any interference received, including interference that may cause undesired operation
- This device complies with Part 18 of the FCC Rules.

This device may cause interference to radio and TV receivers. If interference is experienced, you can determine if this microwave oven is causing the interference by turning it off and on. To eliminate interference, move the receiver farther from the micro-wave oven or plug the receiver into a different AC outlet than the microwave oven.

Record in the space below the SERIAL NO. found on the nameplate on your oven and retain
1. this information for future reference.

SERIAL NO.

PRECAUTIONS TO AVOID POSSIBLE EXPOSURE TO EXCESSIVE MICROWAVE ENERGY

2. Do not attempt to operate this oven with the door-open since open-door operation can result in harmful exposure to microwave energy. It is important not to defeat or tamper with the safety interlocks.
3. Do not place any object between the oven front face and the door or allow soil or cleaner residue to accumulate on sealing surfaces.
4. Do not operate the oven if it is damaged. It is particularly important that the oven door close properly and that there is no damage to the:
 - a. Door (bent),
 - b. Hinges and latches (broken or loosened),
 - c. Door seals and sealing surfaces.
5. The oven should not be adjusted or repaired by anyone except properly qualified service personnel.

CONTENT

PRECAUTIONS TO AVOID POSSIBLE EXPOSURE TO EXCESSIVE MICROWAVE ENERGY	1
IMPORTANT SAFETY INSTRUCTIONS.....	2
INSTALLATION GUIDE.....	3
GROUNDING INSTRUCTIONS.....	3
UTENSILS GUIDE	4
COOKING TECHNIQUES.....	5
SPECIFICATIONS.....	6
PART NAMES	6
CONTROL PANEL	7
HOW TO SET THE OVEN CONTROLS	8
SETTING THE CLOCK	8
MICROWAVE COOKING	8
PRESET	8
EXPRESS	8
GRILL COOKING	8
COMBINATION COOKING	8
JET DEFROST.....	8
WEIGHT DEFROST.....	8
MULTISTAGE COOKING	9
CHILD LOCK.....	9
CLEANING AND CARE.....	10

IMPORTANT SAFETY INSTRUCTIONS

When using electrical appliances, basic safety precautions should be followed, including the following:

WARNING - To reduce the risk of burns, electric shock, fire, injury to persons or exposure to excessive microwave energy:

1. Read all instructions before using the appliance.
2. Read and follow the specific "PRECAUTIONS TO AVOID POSSIBLE EXPOSURE TO EXCESSIVE MICROWAVE ENERGY" on page 1.
3. This appliance must be grounded. Connect only to properly grounded outlet. See "grounding instructions " on page 3.
4. Install or locate this appliance only in accordance with the provided installation instructions.
5. Some products such as whole eggs and sealed containers -for example, closed glass jars- are able to explode and should not be heated in this oven.
6. Use this appliance only for its intended use as described in this manual. Do not use corrosive chemicals or vapors in this appliance. This type of oven is specifically designed to heat, cook, or dry food. It is not designed for industrial or laboratory use.
7. As with any appliance, close supervision is necessary when used by children.
8. To reduce the risk of fire in the oven cavity:
 - a. Do not overcook food. Carefully attend appliance when paper, plastic, or other combustible materials are placed inside the oven to facilitate cooking.
 - b. Remove wire twist-ties from paper or plastic bags before placing bag in oven.
 - c. If materials inside the oven should ignite, keep oven door closed, turn oven off, and disconnect the power cord or shut off power at the fuse or circuit breaker panel.
 - d. Do not use the cavity for storage purposes. Do not leave paper products, cooking utensils or food in the cavity when not in use.
9. Liquids, such as water, coffee, or tea are able to be overheated beyond the boiling point without appearing to be boiling due to surface tension of the liquid. Visible bubbling or boiling when the container is removed from the microwave oven is not always present. **THEIS COULD RESULT IN VERY HOT LIQUIDS SUDDENLY BOILING OVER WHEN A SPOON OR OTHER UTENSIL IS INSERTED INTO THE LIQUID.** To reduce the risk of injury to person:
 - a. Do not overheat the liquid.
 - b. Stir the liquid both before and halfway through heating it.
 - c. Do not use straight-sided containers with narrow necks.
 - d. After heating, allow the container to stand in the microwave oven for a short time before removing the container.
 - e. Use extreme care when inserting a spoon or other utensil into the container.
10. Do not heat oil or fat for deep-frying. It is difficult to control the temperature of oil in microwave oven.
11. Pierce foods with heavy skins such as potatoes, whole squash, apples and chestnuts before cooking.
12. The contents of feeding bottles and baby jars should be stirred or shaken and the temperature should be checked before serving in order to avoid burns.
13. Cooking utensils may become hot because of heat transferred from the heated food. Potholders may be needed to handle the utensil.
14. Do not cover or block any openings on the appliance.
15. Do not store or use this appliance outdoors. Do not use this product near water, for example, near a kitchen sink, in a wet basement, near a swimming pool, or similar locations.
16. Do not operate this appliance if it has a damaged cord or a plug, if it is not working properly or if it has been damaged or dropped.
17. Do not immerse cord or plug in water. Keep cord away from heated surface. Do not let cord hang over edge of table or counter.

SAVE THESE INSTRUCTIONS

18. Use only thermometers, which are specifically designed for use in microwave ovens.
19. Do not operate any heating or cooking appliance beneath this appliance.
20. Be certain the glass tray and roller rings are in place when you operate the oven.
21. This appliance should be serviced only by

qualified service personnel, contact nearest authorized service facility for examination, repair, or adjustment.

22. When cleaning surfaces of door and oven that comes together on closing the door, use only mild, nonabrasive soaps, or detergents applied with a sponge or soft cloth

INSTALLATION GUIDE

- | | |
|---|---|
| <ol style="list-style-type: none"> 1. Make sure that all the packing materials are removed from the inside of the door. 2. Check the oven for any damage, such as misaligned or bent door, damaged door seals and sealing surface, broken or loose door hinges and latches and dents inside the cavity or on the door. If there is any damage, do not operate the oven but contact qualified service personnel. 3. This microwave oven must be placed on a flat, stable surface to hold its weight and the heaviest food likely to be cooked in the oven. 4. Do not place the oven where heat, moisture, or high humidity are generated, or near combustible materials. | <ol style="list-style-type: none"> 5. For correct operation, the oven must have sufficient airflow. Allow 20cm of space above the oven, 10cm at back and 5cm at both sides. Do not cover or block any openings on the appliance. Do not remove feet on which oven stands. 6. The appliance shall be only used on a countertop over 3 feet above the floor. 7. Do not operate the oven without glass tray, roller support, and shaft in their proper positions. 8. Make sure that the power supply cord is undamaged and does not run under the oven or over any hot or sharp surface. 9. The socket must be readily accessible so that it can be easily unplugged in an emergency. |
|---|---|

GROUNDING INSTRUCTIONS

This appliance must be grounded. In the event of an electrical short circuit, grounding reduces risk of electric shock by providing an escape wire for the electric current.

WARNING Improper use of the grounding plug can result in a risk of electric shock.

ELECTRICAL REQUIREMENTS

The electrical requirements are a 120 volt 60

Hz, AC only, 15 amp. It is recommended that a separate circuit serving only the oven be provided. The oven is equipped with a 3-prong grounding plug. It must be plugged into a wall receptacle that is properly installed and grounded.

Power Supply Cord

1. A short power supply cord is provided to reduce the risks resulting from becoming

SAVE THESE INSTRUCTIONS

entangled in or tripping over a longer cord.

2. Longer cord sets or extension cords are available and may be used if care is exercised in their use.

3. If long cord or extension cord is used:

a) The marked electrical rating of the cord set or extension cord should be at least as great as the electrical rating of the appliance.

b) The extension cord must be a grounding-type 3-wire cord, and The longer cord should be arranged so that it will not drape over the counter top or table top where it can be pulled on by children or tripped over

unintentionally.

Notes:

If you have any questions about the grounding or electrical instructions, consult a qualified electrician or service person.

Neither Galanz nor the dealer can accept any liability for damage to the oven or personal injury resulting from failure to observe the electrical connection procedures.

UTENSILS GUIDE

This section lists which utensils can be used in the microwave, which ones have limited use for short periods, and which ones should not be used in the microwave.

RECOMMENDED

Microwave browning dish — Use to brown the exterior of small items such as steaks, chops, or pancakes. Follow the directions provided with your browning dish.

Microwaveable plastic wrap — Use to retain steam. Leave a small opening for some steam to escape and avoid placing it directly on the food.

Paper towels and napkins — Use for short-term heating and covering; these absorb excess moisture and prevent spattering. Do not use recycled paper towels, which may contain metal and could ignite.

Glass and glass-ceramic bowls and dishes — Use for heating or cooking.

Paper plates and cups — Use for short-term heating at low temperatures. Do not use recycled paper, which may contain metal and

could ignite.

Wax paper — Use as a cover to prevent spattering.

Thermometers — Use only those labeled "Microwave Safe" and follow all directions. Check the food in several places. Conventional thermometers may be used on microwave food once the food has been removed from the oven.

LIMITED USE

Aluminum foil — Use narrow strips of foil to prevent overcooking of exposed areas. Using too much foil can damage your oven, so be careful. You should keep distance of 1 inch (2.54cm) between aluminum foil and cavity.

Ceramic, porcelain, and stoneware— Use these if they are labeled "Microwave Safe". If they are not labeled, test them to make sure they can be used safely.

Plastic — Use only if labeled "Microwave Safe". Other plastics can melt.

Not Recommended

Glass jars and bottles — Regular glass is too thin to be used in a microwave. It can shatter and cause damage and injury.

Paper bags — These are a fire hazard, except for popcorn bags that are designed for microwave use.

Styrofoam plates and cups — These can melt and leave an unhealthy residue on food.

Plastic storage and food containers — Containers such as margarine tubs can melt in

the microwave.

Metal utensils — These can damage your oven. Remove all metal before cooking.

Note:

Should you wish to check if a dish is safe for microwaving, place the empty dish in the oven and microwave on HIGH for 30 seconds. A dish which becomes very hot should not be used.

COOKING TECHNIQUES

Your microwave makes cooking easier than conventional cooking, provided you keep these considerations in mind:

STIRRING

Stir foods such as casseroles and vegetables while cooking to distribute heat evenly. Food at the outside of the dish absorbs more energy and heats more quickly, so stir from the outside to the center. The oven will turn off when you open the door to stir your food.

ARRANGEMENT

Arrange unevenly shaped foods, such as chicken pieces or chops, with the thicker, meatier parts toward the outside of the turntable where they receive more microwave energy. To prevent overcooking, place delicate areas, such as asparagus tips, toward the center of the turntable.

SHIELDING

Shield food with narrow strips of aluminum foil to prevent overcooking. Areas that need shielding include poultry wing tips, the ends of poultry legs, and corners of square baking dishes. Use only small amounts of aluminum foil. Larger amounts can damage your oven.

TURNING

Turn foods over midway through cooking to expose all parts to microwave energy. This is especially important with large foods such as roasts.

STANDING

Foods cooked in the microwave build up internal heat and continue to cook for a few minutes after heating stops. Let foods stand to complete cooking, especially foods such as cakes and whole vegetables. Roasts need this time to complete cooking in the center without overcooking the outer areas. All liquids, such as soup or hot chocolate, should be shaken or stirred when cooking is complete. Let liquids stand a moment before serving. When heating baby food, stir well at removal and test the temperature before serving.

ADDING MOISTURE

Microwave energy is attracted to water molecules. Food that is uneven in moisture content should be covered or allowed to stand so that the heat disperses evenly. Add a small amount of water to dry food to help it cook.

SPECIFICATIONS

Power Consumption:	120V~60Hz, 1300W (Microwave)
Output:	800W
Operation Frequency:	2450MHz
Outside Dimensions(H×W×D):	10.3×17.8×13.0 in.
Oven Cavity Dimensions(H×W×D):	8.3×12.4×12.4 in.
Oven Capacity:	0.7 cu.ft
Cooking Uniformity:	Turntable System
Net Weight:	Approx. 26.5 lb. (unsure)

Note: The above data must be confirmed or updated.

PART NAMES

1. Door Safety Lock System
2. Oven Window
3. Cavity floor inside
4. Control Panel

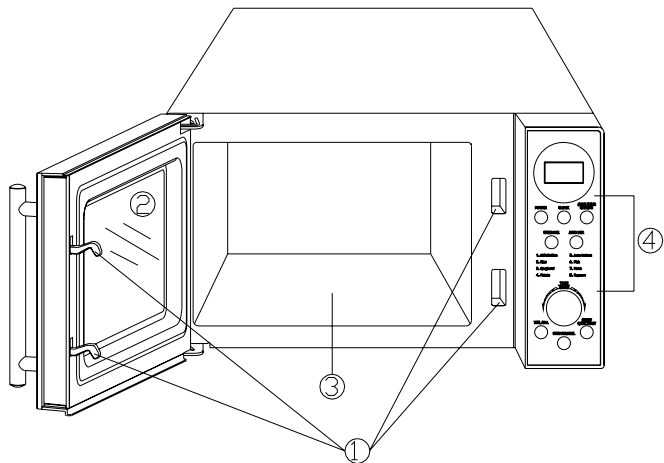

CONTROL PANEL

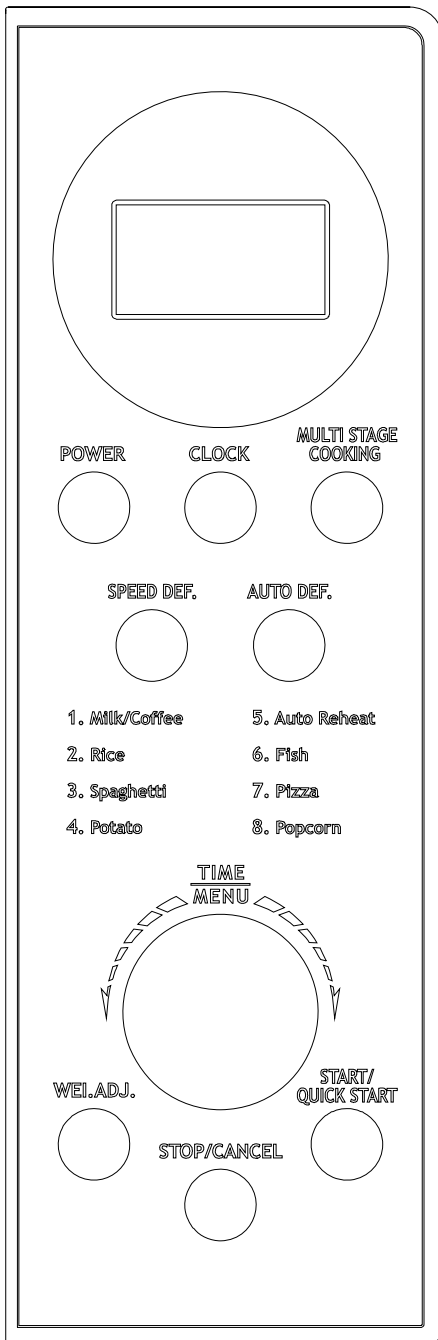

DISPLAY

Cooking time, power, indicators and present time are displayed.

POWER

Use to set power level. To check power level during time cooking, touch POWER pad.

CLOCK

Use to set the time of day or recall the time of day.

MULTI STAGE COOKING

Press this button to set a multi-stage cooking program.

SPEED DEF.

Use to defrost food based on the time entered.

AUTO DEF.

Use to defrost food based on the weight entered.

WEI. ADJ.

Press to specify weight or amount of food to be cooked.

STOP/CANCEL

Press to cancel setting or reset the oven before setting a cooking program.

Press once to temporarily stop cooking, or twice to cancel cooking altogether.

It is also used for setting child lock.

START/QUICK START

Press once to start a cooking or defrosting program.

Press repeatedly to set quick start function.

TIME/MENU

Rotate the dial to enter time or select auto cook menus.



HOW TO SET THE OVEN CONTROLS

Each time a button is touched, a beep will sound to acknowledge the touch.

SETTING THE CLOCK

The oven is equipped with a digital clock, you can choose to set the clock time in 24 or 12-hour cycle by pressing the clock button in waiting mode.

FOR EXAMPLE: Suppose you want to set the oven clock time to 8:30.

1. Press CLOCK button once or twice.
2. Turn TIME/MENU to set 8 o'clock.
3. Press CLOCK button.
4. Turn TIME/MENU to set 30 min.
5. Press CLOCK to confirm the setting.

MICROWAVE COOKING

For microwave cooking, just press the POWER button a number of times to select a cooking power level, and then use the TIME/MENU dial to set a desired cooking time.

Select power level by pressing the POWER button.

PRESS POWER BUTTON	DISPLAY	COOKING POWER
Once	100	100%
Twice	80	80%
3 times	60	60%
4 times	40	40%
5 times (Defrost)	20	20%
6 times (setting timer)	0	0

For example, suppose you want to cook for 1 minute at 60% of microwave power.

1. Press STOP/CANCEL button to reset the oven.
2. Press POWER button 3 times.
3. Turn TIME/MENU to 1:00.
4. Press START/QUICK START button.

NOTE: After all time elapsed, the buzzer will

beeps with END in display, press STOP/CANCEL to clear END before starting another cooking function.

EXPRESS COOKING

The oven will operate at HIGH power (100% power output) for EXPRESS cooking program.

To do this, just press START/QUICK START button in quick succession to set cooking time, the oven starts immediately at full power.

SPEED DEFROST

You can program a speed defrost program based on the time entered. The maximum defrosting time you can enter is 60 minutes.

FOR EXAMPLE: Suppose you want to defrost shrimp for 20 minutes.

1. Place the shrimp to be defrosted into the oven.
2. Press SPEED DEF. button once.
3. Turn TIME/MENU dial to set cooking time.
4. Press START/QUICK START button.

Note: during defrosting process, you'd better turn food over for uniform cooking.

AUTO DEFROST

The oven could be used to food on the weight you entered. The defrosting time and power level are automatically set once the weight is programmed. The weight varies between 100g and 1800g.

FOR EXAMPLE: Suppose you want to defrost 600g of shrimp.

1. Place the shrimp to be defrosted into the oven.
2. Press AUTO DEF. button once.
3. Turn TIME/MENU dial to indicate weight 600g.

4. Press START/ QUICK START button.

NOTE:

During defrosting process, the system will pause to remind user to turn food over, and then depress START/QUICK START to resume the defrosting.

MULTISTAGE COOKING

Your oven can be programmed for up to 3 automatic cooking sequences. Some recipes may require setting a multi-stage program involving speed defrost program.

Suppose you want set the following cooking program:

- ① Speed defrost;
- ② Microwave cooking;

Steps:

1. Input speed defrost program.
2. Press MULTI STAGE COOKING button.
3. Input microwave-cooking program.

ATUO COOK

For food or the following cooking mode, it is not necessary to program the duration and the cooking power. It is sufficient to indicate the type of food that you wish to cook as well as the weight of this food.

You may need to turn food over during cooking time to obtain uniform cooking.

For example: to cook 400g of fish.

1. Turn TIME/MENU dial to fish cooking, which is the item 6 on the auto-menu.
2. Press WEI. ADJ. button repeatedly to indicate weight 400g.
3. Press START/QUICK START button.

Auto cook menu:

CODE	FOOD	NOTES:
1	Milk/Coffee (200ml/unit)	<ol style="list-style-type: none"> 1. The user required to turn TIME/MENU to select one of the auto cook menus and enter the food weight by pressing WEI.ADJ. button. 2. The result of auto cooking depends on factors such as fluctuation of voltage, the shape and size of food, your personal preference as to the
2	Rice (g)	
3	Spaghetti (g)	
4	Potato (230g/unit)	
5	Auto reheat (g)	

4. Touch START/QUICK START button.

NOTE:

SPEED DEFROST can be only set before other cooking stage of the program, AUTO DEFROST and AUTO COOK can not be set in multi-stage cooking program.

After the program ahead finish, the buzzer will beep DE-, signaling the next cooking stage begin.

CHILD LOCK

To set the Child Lock:

In standby mode, press STOP/CANCEL button for 3 seconds, a beep will sound and the child lock indicator light will come on.

To cancel the Child Lock:

Press STOP/CANCEL button for 3 seconds, a beep will sound and the child lock indicator light will go off.

NOTE: You can not operate the oven while the Child Lock is set.

6	Fish (g)	<p>doneness of certain foods and even how well you happen to place food in the oven. If you find the result at any rate not quite satisfactory, please adjust the cooking time a little bit accordingly.</p> <p>3. For Spaghetti add boiling water before cooking.</p>
7	Pizza (g)	
8	Popcorn (99g)	

CLEANING AND CARE

1. Turn off the oven and remove the power plug from the wall socket before cleaning.
2. Keep the inside of the oven clean. When food splatters or spilled liquids adhere to oven walls, wipe with a damp cloth. Mild detergent may be used if the oven gets very dirty. Avoid the use of spray and other harsh cleaners as they may stain, streak or dull the door surface.
3. The outside surfaces should be cleaned with a damp cloth. To prevent damage to the operating parts inside the oven, water should not be allowed to seep into the ventilation openings.
4. Wipe the door and window on both sides, the door seals and adjacent parts frequently with a damp cloth to remove any spills or splatters. Do not use abrasive cleaner.
5. Do not allow the control panel to become wet. Clean with a soft, damp cloth. When cleaning the control panel, leave oven door open to prevent oven from accidentally turning on.
6. If steam accumulates inside or around the outside of the oven door, wipe with a soft cloth. This may occur when the microwave oven is operated under high humidity condition. And it is normal.
7. It is occasionally necessary to remove the glass tray for cleaning. Wash the tray in warm sudsy water or in a dishwasher.
8. The roller ring and oven floor should be cleaned regularly to avoid excessive noise. Simply wipe the bottom surface of the oven with mild detergent. The roller ring may be washed in mild sudsy water or dishwasher. When removing the roller ring from cavity floor for cleaning, be sure to replace in the proper position.
9. Remove odors from your oven by combining a cup of water with the juice and skin of one lemon in a deep microwaveable bowl, microwave for 5 minutes. Wipe thoroughly and dry with a soft cloth.
10. When it becomes necessary to replace the oven light, please consult a dealer to have it replaced.
11. The oven should be cleaned regularly and any food deposits removed. Failure to maintain the oven in a clean condition could lead to deterioration of the surface that could adversely affect the life of the appliance and possibly result in a hazardous situation.
12. Please do not dispose this appliance into the domestic rubbish bin, it should be disposed to the particular disposal center provided by the municipalities.