

Hamilton Beach®

MICROWAVE OVEN

Owner's Manual

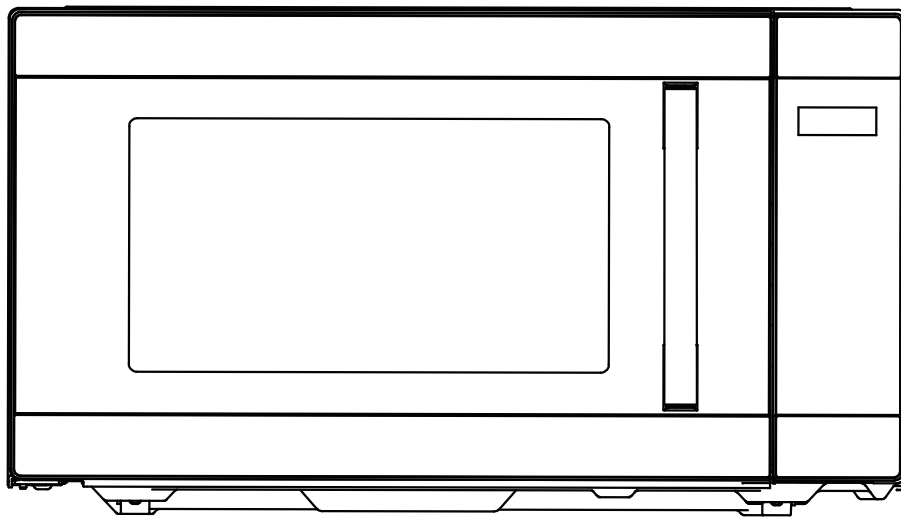

READ BEFORE USE

Model No. HB8436127995-03

Hamilton Beach® is a registered trademark of Hamilton Beach Brands, Inc.
used under license by Wal-Mart Stores, Inc.

Microwave Oven

Owner's Manual



Safety Information.....

2

Welcome.....	2
Grounding.....	4
Excessive Energy Warning.....	5
Features And Benefits, Specifications.....	5



Operating Your Microwave.....

7

Setting Up Your Microwave.....	7
Parts And Accessories.....	7
Turntable Installation.....	7
Control Panel.....	8
Operation.....	9

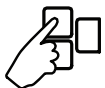

Sensor Cook Feature.....

13

Popcorn.....	13
Beverage.....	13
Baked Potato.....	14
Frozen Dinner.....	14
Pizza.....	14
Reheat.....	14
Fish.....	14



Use And Care.....

16

Care And Cleaning.....	16
Troubleshooting.....	17
Warranty.....	18
Technical Support.....	18

Welcome!

Congratulations, you have acquired a high-quality Hamilton Beach™ Microwave Oven. This unit is packed with many extra features that you will find convenient to use, including six different one-touch cooking buttons provide for convenient meal preparation and tasty snacks. Follow the safety precautions and operating instructions provided in this easy-to-use manual. Please take the time to read it, and save these instructions for future use. Please also remember to record the model, series code and serial number. They are on the label on the back of the unit. Save your receipt by stapling it to this manual for convenient access.

Model number: HB8436127995-03

Serial number _____

Series code _____

Date of purchase _____

!! IMPORTANT SAFETY INSTRUCTIONS !!

When using electrical appliances, basic safety precautions should always be followed, including the following:

WARNING! - To reduce the risk of burns, electric shock, fire, injury to persons, or exposure to excessive microwave energy:

1. Read all instructions before using the appliance.
2. Read and follow the specific PRECAUTIONS TO AVOID POSSIBLE EXPOSURE TO EXCESSIVE MICROWAVE ENERGY found on page 5.
3. This appliance must be grounded. Connect only to properly grounded outlet. See "IMPORTANT GROUNDING INSTRUCTIONS" found on page 4.
4. Install or locate this appliance only in accordance with the provided installation instructions.
5. Some products such as whole eggs and sealed containers, like closed glass jars, are able to explode and should not be heated in this oven.
6. Use this appliance only for its intended use as described in the manual. Do not use corrosive chemicals or vapors in this appliance. This type of oven is specifically designed to heat, cook, or dry food. It is not designed for industrial or laboratory use.
7. As with any appliance, close supervision is necessary when used by children.

Hamilton Beach®

8. Do not operate this appliance if it has a damaged cord or plug, if it is not working properly, or if it has been damaged or dropped.
9. This appliance should be serviced only by a qualified service personnel. Contact your nearest authorized service facility for examination, repair or adjustment.
10. Do not cover or block any openings on this appliance.
11. Do not store this appliance outdoors. Do not use this product near water. For example, do not use near a kitchen sink, in a wet basement, near a swimming pool, or similar locations.
12. Do not immerse cord or plug in water.
13. Keep cord away from heated surfaces.
14. Do not let cord hang over edge of table or counter.
15. When cleaning the surfaces between the door and the oven that come together upon closing, use only mild, non-abrasive soaps or detergents applied with a sponge or soft cloth.
16. To reduce the risk of fire in the oven cavity:
 - Do not overcook food. Carefully attend appliance when paper, plastic, or other combustible materials are placed inside the oven to facilitate cooking.
 - Remove wire twist ties from paper or plastic bags before placing bag in oven.
 - If materials inside the oven ignite, keep oven door closed, turn oven off and disconnect the power cord, or shut off power at the fuse or circuit breaker panel.
 - Do not use the cavity for storage purposes. Do not leave paper products, cooking utensils, or food in the cavity when not in use.
17. Liquids such as water, coffee, or tea are able to be overheated beyond the boiling point without appearing to be boiling. Visible bubbling or boiling when the container is removed from the microwave oven is not always present. **THIS COULD RESULT IN VERY HOT LIQUIDS SUDDENLY BOILING OVER WHEN THE CONTAINER IS DISTURBED OR A UTENSIL IS INSERTED INTO THE LIQUID.**
18. This appliance is intended for household use only.

!! SAVE THESE INSTRUCTIONS !!

Important Grounding Instructions

This appliance must be grounded. In the event of an electrical short circuit, grounding reduces the risk of electric shock by providing an escape wire for the electric current.

WARNING Improper use of the grounding plug can result in a risk of electric shock.

**Three-pronged
(grounding) plug**

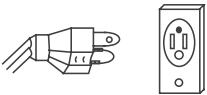

**Properly
polarized and
grounded
outlet**

Electrical Requirements

The electrical requirements are 120 volt 60 Hz, AC only, 20 amp.

It is recommended that a separate circuit serving only the oven be provided. The oven is equipped with a 3-prong grounding plug. It must be plugged into a wall receptacle that is properly installed and grounded.

Power Supply Cord

1. A short power supply cord is provided to reduce the risks resulting from becoming entangled in or tripping over a longer cord.
2. Longer cord sets or extension cords are available and may be used if care is exercised in their use.
3. If long cord or extension cord is used:
 - a) The marked electrical rating of the cord set or extension cord should be at least as great as the electrical rating of the appliance.
 - b) The extension cord must be a grounding-type 3-wire cord, and the longer cord should be arranged so that it will not drape over the counter top or table top where it can be pulled on by children or tripped over unintentionally.

NOTE:

If you have any questions about the grounding or electrical instructions, consult a qualified electrician or service person.

Neither manufacturer nor the dealer can accept any liability for damage to the oven or personal injury resulting from failure to observe the electrical connection procedures.

Radio or TV Interference

Should there be any interference caused by the microwave oven to your radio or TV, check that the microwave oven is on a different circuit, relocate the radio or TV as far away from the oven as feasible or check position and signal of receiving antenna. This device complies with part 18 of the FCC rules.

Hamilton Beach®



Precautions To Avoid Possible Exposure To Excessive Microwave Energy

- Do not attempt to operate this oven with the door open since open-door operation can result in harmful exposure to microwave energy. It is important not to defeat or tamper with the safety interlocks.
- Do not place any object between the oven front face and the door or allow soil or cleaner residue to accumulate on sealing surfaces.
- Do not operate the oven if it is damaged. It is particularly important that the oven door is close properly and that there is no damage to the:
 1. Door (bent).
 2. Hinges and latches (broken or loosened).
 3. Door seals and sealing surfaces.
- The oven should not be adjusted or repaired by anyone except properly qualified service personnel.

Features and Benefits

- 1.6 cu. ft. Oven Cavity
- 10 Power Levels
- Seven Sensor Settings
- Electronic Digital Display With Clock (LED)
- Turntable
- Time Cook
- Weight Defrost
- Time Defrost
- Kitchen Timer

Specifications

Model.....	HB8436127995-03
Power Source.....	120V ~ 60Hz
Power Consumption.....	1500W
Maximum Output	1100W
Oven Capacity.....	1.6 cu. ft.
Turntable Diameter	12.4 inches
External Dimensions.....	12.2 x 21.8 x19.8 inches
Net Weight	35.71 lbs

How To Test For A Microwave Safe Dish

To determine if a dish is microwave-safe, place the dish in the microwave along with a glass measuring cup filled with one cup of water. Microwave for one minute on high and then carefully feel the dish. If it is warm, it is not microwave-safe.

Arcing - The microwave term for sparks in the oven. Caused by:

- Metal or foil touching the side of the microwave.
- Upturned edges of foil not wrapped around the food.
- Metals in the microwave such as twist ties, meat pins or metal rimmed dishes.
- Recycled paper towels in the microwave that contain small flecks of metal.

Materials For Use In Microwave

To avoid arcing and other hazards, follow these instructions for the use of safe materials in the microwave.

Browning dish	Follow manufacturer's instructions. The bottom of browning dish must be at least 3/16 inch (0.5 cm) above the turntable. Incorrect usage may cause the turntable to break.
Dinnerware	Microwave-safe only. Follow manufacturer's instructions. Do not use cracked or chipped dishes.
Glassware	Heat-resistant oven glassware only. Make sure there is no metallic trim.
Oven cooking bags	Follow manufacturer's instructions. Do not close with metal tie. Make slits to allow steam to escape.
Paper plates/cups	Use for short-term cooking/warming only. Do not leave oven unattended while cooking.
Paper towels	Use to cover food for reheating and absorbing fat. Use with supervision for short-term cooking only.
Parchment paper	Use as a cover to prevent splattering or a wrap for steaming.
Plastic	Microwave-safe only. Follow the manufacturer's instructions. Boiling bags and tightly closed plastic bags should be slit, pierced or vented as directed by package. When using a bacon tray, cooking performance result may vary as it is manufactured by different manufacturers.
Plastic wrap	Microwave-safe only. Use to cover food during cooking to retain moisture. Do not allow plastic wrap to touch food.
Thermometers	Microwave-safe only.
Wax paper	Use as a cover to prevent splattering and retain moisture.

Materials To Avoid In Microwave

- Metal pans and bakeware
- Recycled paper products
- Non-heat resistant
- Food storage bags
- Dishes with metallic trim
- Brown paper bags
- Non-microwave safe plastics (e.g. margarine tubs)
- Metal twist ties

Hamilton Beach®

Setting Up Your Microwave

Installation:

1. Remove all packing materials and accessories. Examine the oven for any damage such as dents or broken door. Do not install if oven is damaged.
2. Select a level surface that provides enough open space for ventilation. Allow for 3 inches of open space next to the sides and back of the microwave. Allow for 12 inches of open space above the microwave. Do not place any items on top of microwave and do not remove the legs from the bottom of the microwave.
3. Place the microwave as far away as possible from radios and televisions. Microwave may cause interference to these appliances.
4. Plug the microwave into a grounded household outlet. Check the rating label of the microwave to ensure the voltage and frequency are compatible with the outlet.
5. Do not install microwave oven over a range cook top or other heat-producing appliance. Heat can damage the microwave and void the warranty.

Names of Oven Parts and Accessories

Remove the oven and all materials from the carton. Your oven comes with the following accessories:

Glass tray	1
Turntable ring assembly	1
Instruction manual	1

1. Safety interlock system
2. Observation window
3. Turntable ring
4. Turntable shaft
5. Control panel
6. Wave guide cover (do not remove)
7. Glass tray

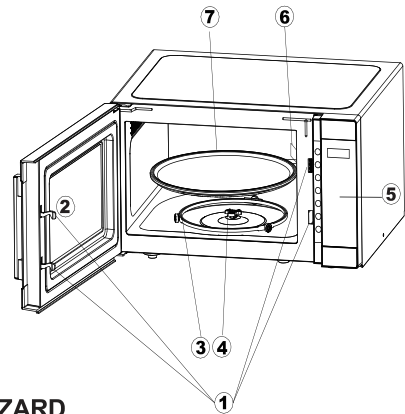

WARNING : FIRE AND SHOCK HAZARD.

Do not remove the wave guide cover located on the right, inside wall of the cooking compartment. Unplug the microwave immediately and contact service support: **1-855-313-1612** if the wave guide cover is damaged or missing.

Turntable Installation

Hub (underside)

Glass tray

Turntable shaft

Turntable ring assembly

1. Never place the glass upside down. The glass tray should never be restricted.
2. Both glass tray and turntable ring assembly must always be used during cooking.
3. All food and containers of food are always placed on the glass tray for cooking.
4. The glass tray rotates either clockwise or counter-clockwise; this is normal.
5. If the glass tray or turntable ring assembly cracks or breaks, contact service support: **1-855-313-1612**.

To order a replacement turntable, please call service support: **1-855-313-1612**.

Control Panel Operation

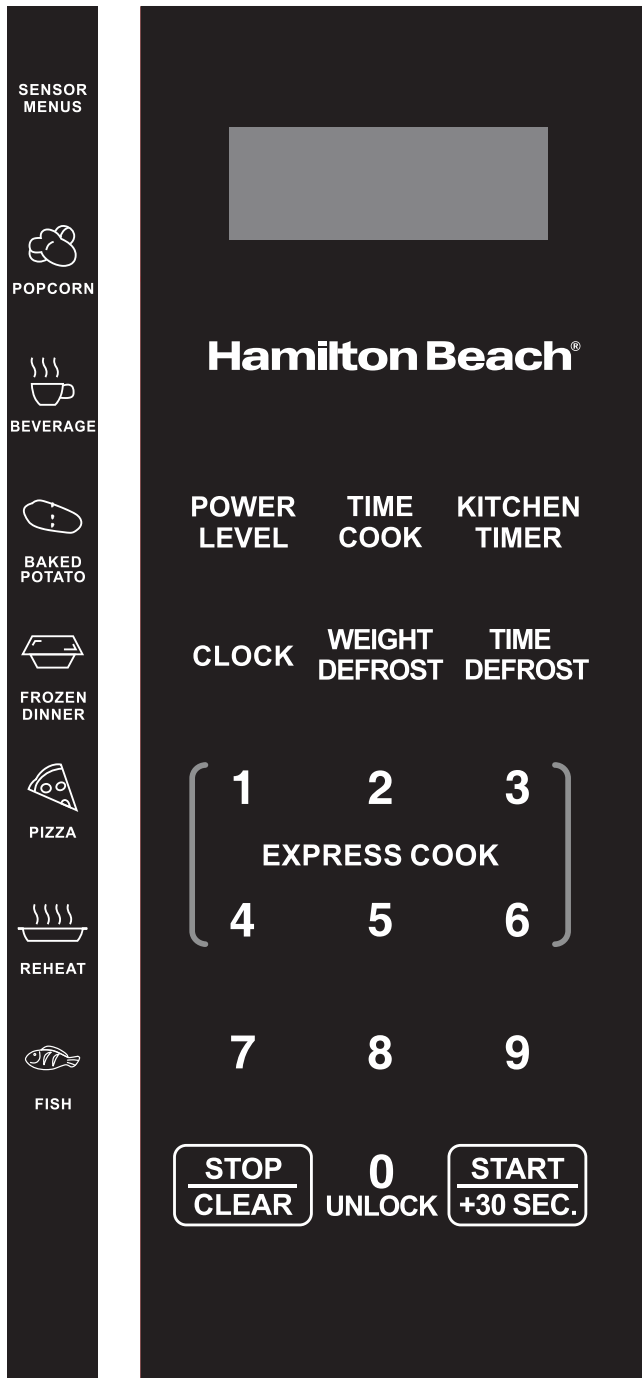

◆ MENU ACTION SCREEN

Cooking time, power, indicators and present time are displayed.

◆ SENSOR COOK MENUS

Instant setting to cook popular foods.

◆ POWER LEVEL

Press to set microwave power levels.

◆ TIME COOK

Press to set microwave cooking program.

◆ KITCHEN TIMER

Press to set timer function.

◆ CLOCK

Press to set clock time.

◆ WEIGHT DEFROST

Press to set defrost program based on weight.

◆ TIME DEFROST

Press to set defrost program based on time.

◆ EXPRESS COOK

Number pads (1-6).

◆ NUMBER PADS (0-9)

Press to set time, weight or amount.

◆ STOP/CLEAR

Press once to temporarily stop cooking, or twice to cancel cooking altogether. It is also used to set the control panel lock.

◆ START/ +30 SEC.

Press to start a cooking program. It is also used to set quick start function or to increase cooking time during cooking.

◆ 0/UNLOCK

Press once to unlock when child safety door lock is activated. During function selection, the 0/UNLOCK pad serves as a number pad for 0.

Hamilton Beach®

Operation Instructions

1. Setting The Clock

This is a 12 or 24 hour clock, and you can select it by pressing CLOCK pad. During cooking, the current time can be checked for 5 seconds by pressing CLOCK pad.

For example: Suppose you want to set the oven clock time to 8:30.

1. In standby mode, press CLOCK pad once to select 12 hour clock, press again to select 24 hour clock.

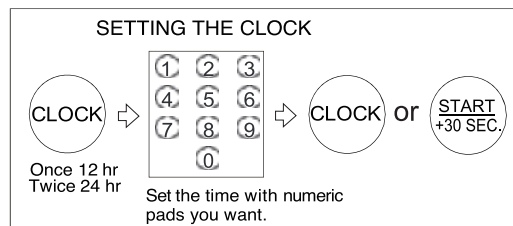

2. Use the number pads to enter the correct time (press number pads 8, 3 then 0 in sequence to enter 8:30).
3. Press CLOCK or START/ +30 SEC. pad once to confirm.

2. Setting The Child Safety Door Lock

How Does The Child Safety Lock Functions

1. Using the microwave for the first time:

- When the microwave is power on, the microwave is in child safety door lock mode, the door can be opened at any time and the door is unlocked before any cooking programs starts.

2. During cooking:

- When cooking function starts, the door is locked automatically and immediately.
- If you want to open the door during cooking:
 - (i) Press 0/UNLOCK pad once to unlock, the cooking function is paused (showing remaining cooking time) and you can open the door now.
 - (ii) Or press STOP/CLEAR pad once, the cooking function is paused (showing remaining cooking time), then press 0/UNLOCK pad once to unlock and you can open the door now.
- To continue cooking, press START/+30 SEC. pad once to resume cooking, the door will be automatically and immediately locked.

NOTE:

- If cooking function is not resumed after closing the door, the door will be in unlocked status.
- If you press 0/UNLOCK pad once without opening the door within 10 seconds, the door will lock again and a beep will be heard.
- If you push the door release button without pressing 0/UNLOCK pad, cooking will pause and the display will show remaining cooking time, the door cannot be opened as it is locked.

Hamilton Beach®

- If you press STOP/CLEAR pad twice, cooking function will be cancelled and the display will show "Loc" as the door is locked. You need to press 0/UNLOCK pad once to unlock before opening the door.

3. When cooking is completed:

- (i) The display will alternately show "End" or "Loc" every 5 seconds and the microwave will beep to remind every 2 minutes until STOP/CLEAR pad is pressed or after the door is opened.
- (ii) To open the door, press 0/UNLOCK pad once to unlock and you can open the door now. After the door is opened and closed, the door remains unlocked until a new cooking cycle is started.

NOTE:

- If you press 0/UNLOCK pad once without opening the door within 10 seconds, the door will lock again and a beep will be heard.
- If the door is not opened after cooking is completed, the door will remain locked for 30 minutes before returning to standby mode. After 30 minutes, the door can be opened at any time until a new cooking cycle is started.

Deactivating And Reactivating The Electromagnetic Child Safety Lock

1. To deactivate the child safety lock function:

- (i) In standby mode, press and hold 0/UNLOCK pad for 3 seconds.
- (ii) When display shows "Loc", press 7 pad and then 9 pad, the display will show "ULoc" and the buzzer will beep once.
- (iii) The child safety door lock mode is now deactivated and the door can be opened at any time.

2. To reactivate the child safety lock function after deactivating:

- (i) In standby mode, press and hold 0/UNLOCK pad for 3 seconds.
- (ii) When display shows "ULoc", press 7 pad and then 9 pad, the display will show "Loc" and the buzzer will beep once.
- (iii) The child safety lock mode is now reactivated, the door will be locked automatically and immediately when cooking starts.

NOTE:

- When deactivating or activating the child safety lock function, 7 pad and then 9 pad must be pressed within 10 seconds after the display shows "Loc" or "ULoc".
- Only 7 and 9 number pads are valid within the 10 second time frame, other pads are invalid. Two short beeps will be heard to remind you that it is an invalid input. If no correct steps are taken within the 10 seconds, the system will return to standby mode.
- During function selection, 0/UNLOCK pad serves as a number pad for 0.
- When the microwave is powered on again after power outage, child safety door lock function will remain activated or deactivated depending on your previous setting.

Hamilton Beach®

3. Setting The Kitchen Timer

1. In standby mode or during cooking, press KITCHEN TIMER pad once (Display shows "00:00").
2. Enter the amount of time you want to count down using the number pads, the longest time you can set is 99 minutes and 99 seconds.
3. Press KITCHEN TIMER or START/+30 SEC pad once to confirm and the system will start to count down.

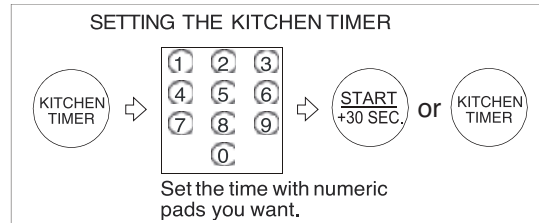

NOTE:

- The buzzer will beep to remind when countdown ends.
- Countdown can be checked by pressing KITCHEN TIMER pad once, if STOP/CLEAR pad is pressed when display is showing the countdown, the function will be cancelled.

4. Add 30 Sec.

1. In standby mode, press START/+30 SEC. pad repeatedly to enter cooking time, each press increases by 30 seconds, up to 99 minutes and 99 seconds can be set.
2. The oven will start automatically at full power level.
3. During cooking (Microwave Cooking and Express Cook), you can add cooking time by pressing the START/+30 SEC. pad.

5. Microwave Cooking

1. In standby mode, press TIME COOK pad once.
2. Use the number pads to set cooking time, the longest time you can set is 99 minutes and 99 seconds.
3. Press POWER LEVEL pad once (default power is 100%), then use the number pads to set other power levels.
4. Press START/+30 SEC. pad once to start.

Use the number pads to set cooking power level:

Number Pad	Display	Power Level
1,0	PL10	100%
9	PL-9	90%
8	PL-8	80%
7	PL-7	70%
6	PL-6	60%
5	PL-5	50%

Number Pad	Display	Power Level
4	PL-4	40%
3	PL-3	30%
2	PL-2	20%
1	PL-1	10%
0	PL-0	0%

NOTE:

- During cooking, you can press POWER LEVEL pad once to check cooking power.
- During cooking, you can press START/+30 SEC. pad continually to increase cooking time.

6. Setting Weight Defrost

1. Place food in oven and close the door.
2. In standby mode, press WEIGHT DEFROST pad once, display shows "dEF1".
3. Press WEIGHT DEFROST pad continually to select defrost food type (dEF1-Meat, dEF2-Poultry and dEF3-Seafood).
4. Enter the food weight by pressing the number pads.
5. Press START/+30 SEC. pad once to start.

Food Type	Display	Weight Range	Total Time
Meat	dEF1	1 oz to 96 oz	32 s/oz
Poultry	dEF2	1 oz to 64 oz	30 s/oz
Seafood	dEF3	1 oz to 32 oz	25 s/oz

NOTE:

- During defrost, the microwave will pause and buzzer will beep as a reminder to turn food over. After turning over food, close the door and press START/+30 SEC. pad once to continue.

7. Setting Time Defrost

1. Place food in the oven and close the door.
2. In standby mode, press TIME DEFROST pad once, display shows "0:00".
3. Enter desired defrosting time using the number pads, the longest time you can set is 99 minutes and 99 seconds.
4. Press START/+30 SEC. pad once to start.

NOTE:

- During defrost, the microwave will pause and buzzer will beep as a reminder to turn food over. After turning over food, close the door and press START/+30 SEC. pad once to continue.

8. Sensor Cook Feature

It detects the humidity in food and automatically adjusts the cooking time according to food type and weight. Please follow the below recommendations to ensure best results with sensor cook:

Hamilton Beach®

- 1) Keep glass tray, container and inside of the microwave dry before placing food in it (extra moisture will mislead the sensor).
- 2) Cover food with lid or vented plastic wrap, not with tightly sealed plastic containers.

NOTE:

- During humidity detection, the system will check if there is error:
 - a) If error occurs (for example the sensor is short circuit or open circuit), the system will stop automatically with display showing "E-5", buzzer will beep every 2 seconds until STOP/CLEAR pad is press and it will return to standby mode.
 - b) If no error is detected, the microwave oven will start and display will flash. When the released steam is detected by the oven, the system will adjust the cooking time automatically and countdown will be displayed. Once cooking is done, the buzzer will beep and display will show 'End'.
 - c) If you open the oven door or press STOP/CLEAR pad during humidity detection, cooking will stop and it will return to standby mode.
 - d) If the sensor could not sense the humidity in food within the time set range, sensor cook ends automatically.
 - e) Do not use sensor cook feature on the same food twice in succession as that may result in food being overcooked severely.

1) Popcorn

For a 3.5 oz bag of microwave popcorn:

1. Press POPCORN pad once, display shows "SC-1", then press POPCORN pad again, display shows "3.5".
2. Press START/+30 SEC. pad once to start. When the released steam is detected by the oven, display will show remaining cooking time.

NOTE:

- To pop the popcorn bag evenly and avoid burning, the bag must be able to rotate freely during cooking. Please listen to the popping sound and watch the bag until popping has been completed.
- Some microwave popcorn bags may be larger, make sure the bag matches the correct weight of 3.5 ounces.
- As the content can be very hot, use an oven mitt or pot holder when removing the popcorn bag.

2) Beverage

For 1 cup to 3 cups, with serving size of 200 ml per cup:

1. Press BEVERAGE pad once, display shows "SC-2".
2. Press BEVERAGE pad once for 200 ml, press BEVERAGE pad twice for 400 ml or press BEVERAGE pad thrice for 600 ml.
3. Press START/+30 SEC. pad once to start, display will show remaining cooking time.

3) Baked Potato

For potatoes of 6 oz to 24 oz:

1. Press BAKED POTATO pad once, display shows "SC-3".
2. Press START/+30 SEC. pad once to start. When the released steam is detected by the oven, display will show remaining cooking time.

4) Frozen Dinner

For frozen dinners of 8 oz to 28 oz:

1. Press FROZEN DINNER pad once, display shows "SC-4".
2. Press START/+30 SEC. pad once to start. When the released steam is detected by the oven, display will show remaining cooking time.

5) Pizza

For pizza of 6 oz to 18 oz:

1. Press PIZZA pad once, display shows "SC-5".
2. Press START/+30 SEC. pad once to start. When the released steam is detected by the oven, display will show remaining cooking time.

6) Reheat

For reheating food of 8 oz to 28 oz:

1. Press REHEAT pad once, display shows "SC-6".
2. Press START/+30 SEC. pad once to start. When the released steam is detected by the oven, display will show remaining cooking time.

7) Fish

For fish of 8 oz to 28 oz:

1. Press FISH pad once, display shows "SC-7".
2. Press START/+30 SEC. pad once to start. When the released steam is detected by the oven, display will show remaining cooking time.

Hamilton Beach®

9. Express Cook

This function can help you to set microwave cooking program quickly without setting power level.

1. Place food in the oven and close the door.
2. In standby mode, press EXPRESS COOK pad 1 to 6, the oven will start automatically at full power level.

Press Number Pad	Time	Press Number Pad	Time
1	1 Minute	4	4 Minutes
2	2 Minutes	5	5 Minutes
3	3 Minutes	6	6 Minutes

10. Two-Stage Cooking

For recipes which require different stages of cooking at different temperatures.

Set Stage 1:

1. In standby mode, press TIME COOK pad once.
2. Use the number pads to set cooking time, the longest time you can set is 99 minutes and 99 seconds.
3. Press POWER LEVEL pad once (default power is 100%), then use the number pads to set other power levels.
4. To input **Stage 2** cooking, press TIME COOK pad once.
5. Use the number pads to set cooking time, the longest time you can set is 99 minutes and 99 seconds.
6. Press POWER LEVEL pad once (default power is 100%), then use the number pads to set other power levels.
7. Press START/+30 SEC. pad once to start.

NOTE:

- Only Microwave Cooking can be set in Two-Stage Cooking. Add 30 Sec., Weight Defrost, Time Defrost and Sensor Cook cannot be set in Two-Stage Cooking.
- When Stage 1 cooking ends, buzzer will beep before starting cooking for Stage 2.

11. Setting Control Panel Lock

Control panel lock prevents unsupervised operation by children.

A. To set the control panel lock:

In standby mode, press and hold the STOP/CLEAR pad for 3 seconds, the display will show  for 3 seconds and the buzzer will beep once. The control panel lock is activated and all pads are disabled.

B. To cancel the control panel lock :

In standby mode, press and hold the STOP/CLEAR pad for 3 seconds and the buzzer will beep once. The control panel lock is deactivated and all pads are enabled.

Care and Cleaning

- Turn off the microwave and unplug the power cord from the wall socket when cleaning.
- Keep the inside of the microwave clean. When food splatters or spilled liquids adhere to microwave walls, wipe with a damp cloth. Mild detergents may be used if the microwave gets very dirty. Avoid using spray or other harsh cleaners. They may stain, streak, or dull the door surface.
- The outside of the microwave should be cleaned with a damp cloth. To prevent damage to the operating parts inside the microwave, water should not be allowed to seep into the ventilation openings.
- Wipe the window on both sides with a damp cloth to remove any spills or splatters.

Hamilton Beach®

- Do not allow the control panel to become wet. Clean with a soft, damp cloth. When cleaning the panel, leave the microwave door open to prevent it from accidentally turning on.
- If steam accumulates inside or around the outside of the door, wipe with a soft cloth. This may occur when the microwave is operated under high humidity. This is normal.
- It may be necessary to remove the glass tray for cleaning. Wash the tray in warm, soapy water or in a dishwasher. The roller ring and microwave floor should be cleaned regularly to avoid excessive noise. Wipe the bottom surface of the microwave with a mild detergent.
- The roller ring may be washed in mild, soapy water or in a dishwasher. When removing the roller ring, place it back in proper position.
- Remove odors from your microwave by combining a cup of water with the juice and skin of one lemon in a microwaveable bowl. Microwave for 5 minutes. Wipe thoroughly and dry with a soft cloth.
- If the light bulb burns out, please contact a certified electrician to have it replaced.
- The microwave should be cleaned regularly and any food deposits should be removed. Failure to maintain the microwave in a clean condition could lead to deterioration of surfaces that could adversely affect the life of the unit and could possibly result in a hazardous situation.
- Please do not dispose of this appliance into a regular garbage receptacle. Please check to see where you can dispose of such appliances.



Troubleshooting

Problem	Possible Causes	What to do
Dim oven light	In low power cooking, oven light may become dim	This is normal
Steam accumulating on door or hot air coming out of vents during cooking	Food releases steam during cooking	This is normal
Oven is started accidentally with no food in it	Microwave is started accidentally with no food in it	No damage will occur if the microwave runs for less than 20 seconds
Interference with TV reception	Microwave operation may affect radio and TV reception	This is normal
Microwave will not start	a. Power cord not plugged in tightly b. A fuse is blown or circuit breaker trips c. Problem with electrical outlet	Unplug, wait 10 seconds, then plug in again Replace fuse or reset circuit breaker Consult with professional electrician
Glass turntable makes noise during operation	The microwave cavity is dirty	Clean the microwave and turntable with warm water and microwave-safe cleaning products
Popcorn is over-cooked or under-cooked with "Popcorn" easy setting	Incorrect power level selected for size of popcorn bag	Refer to page 13 for "Popcorn" setting instructions. Always follow manufacturer's instructions for popcorn if the cooking time for the pre-set setting differs from the manufacturer's recommended time. Never leave popcorn cooking unattended.

Hamilton Beach®

ONE YEAR LIMITED WARRANTY

This is the only express warranty for this product and is lieu of any other warranty. This product carries a warranty that it will be free from defects in material and workmanship for a period of one year from the date of original purchase or date of delivery, whichever is later. This warranty is valid for the original retail purchaser or gift recipient from the date of initial retail purchase or date of delivery and is not transferable. Keep your original sales receipt as proof of purchase is required to make a warranty claim.

IMPORTANT: This warranty does not cover damages resulting from use not in conformity with the printed directions, accident, misuse or abuse, alternation, the affixing of any attachments not provided with the product, loss of parts, or subjecting the appliance to any but the specific voltage (Read directions carefully).

If service is required during the warranty period, properly pack your unit. We recommend using the original carton and packing materials. Within 90 days from point of purchase, return the product to your nearest Walmart store with the sales receipt. A replacement or refund may be offered at the discretion of Walmart. For service after 90 days, up to 1 year from the point of purchase, contact customer assistance at: 1-855-313-1612. For faster service, locate the model number and product name on your appliance.

Walmart expressly disclaims all responsibility for consequential damages or incidental losses caused by use of the appliance. **Every implied warranty, including any statutory warranty of merchantability or fitness for a particular propose, is disclaimed except to the extent prohibited by law, in which case such warranty is limited to the duration of this written warranty.** Some states do not allow this exclusion or limitation of incidental or consequential losses so the foregoing disclaimer may not apply to you. This warranty gives you specific legal rights, and you may also have other rights which may vary from state to state.

SAVE THIS FOR YOUR RECORDS

Hamilton Beach® is a registered trademark of Hamilton Beach Brands, Inc. used under license by Wal-Mart Stores, Inc. Bentonville, AR 72716.

Made in China

PARTE NO.20240601

UN AÑO DE GARANTÍA LIMITADA

Esta es la única garantía expresa de este producto y sustituye cualquier otra garantía. El producto está garantizado contra defectos de materiales y mano de obra durante un año a partir de la fecha de compra original o la fecha de entrega, lo que sea más tarde. Esta garantía es válida para el comprador minorista original o el receptor del regalo desde la fecha de la primera compra minorista o la fecha de entrega y no es transferible. Por favor, conserve su recibo de venta original. El recibo de venta se requiere como prueba de compra cuando se requiere una reclamación de garantía.

IMPORTANTE: Esta garantía no cubre los daños por el uso no conforme con las instrucciones impresas, accidente, mal uso o abuso, alteración, fijación de cualquier accesorio no suministrado con el producto, pérdida de piezas o exposición del aparato cualquier voltaje no especificado (Lea las instrucciones cuidadosamente)

Si requiere mantenimiento durante el período de garantía, empaquete de forma apropiada su unidad. Se recomienda usar el cartón original y los materiales de embalaje. Dentro los 90 días desde el momento de compra, devuelva el producto a su tienda Walmart más cercana con el recibo de compra. A discreción de Walmart, se puede ofrecer el reemplazo o reembolso. Para el mantenimiento después de 90 días hasta 1 año desde el momento de la compra, contacte con asistencia al cliente en: 1-855-313-1612.

Para agilizar el servicio, busque el número de modelo y el nombre del producto en su electrodoméstico.

Walmart niega expresamente toda responsabilidad por daños consecuentes o pérdidas incidentales causadas por el uso del aparato. **Cada garantía implícita, incluyendo cualquier garantía legal de comerciabilidad o aptitud para un propósito particular, es rechazada a excepción de aquellos casos prohibidos por la ley, en cuyo caso esta garantía se limita a la duración de esta garantía escrita.** Algunos estados permiten esta exclusión o limitación de pérdidas incidentales o consecuentes, por lo que renuncia anterior puede no aplicarse en su caso. Esta garantía le otorga derechos legales específicos, y usted también puede tener otros derechos que pueden variar de estado a estado.

GUARDE ESTE DOCUMENTO PARA SU ARCHIVO

Hamilton Beach® es una marca registrada de Hamilton Beach Brands, Inc., utilizada bajo licencia por Wal-Mart Stores, Inc. Bentonville, AR 72716.

Hecho en China

PARTE NO. 20240601