

# FCC REPORT (Bluetooth)

**Applicant:** Shenzhen Shuaixian Electronic Equipment Co.,Ltd.  
**Address of Applicant:** NO.10 Lane 3,Longxing Road, Dakang Long Village,  
Henggang Town, Shenzhen, China  
**Equipment Under Test (EUT)**  
Product Name: Bluetooth earphones  
Model No.: SX-971  
Trade mark: Suicen  
**FCC ID:** UHB-SX971  
**Applicable standards:** FCC CFR Title 47 Part 15 Subpart C Section 15.247  
**Date of sample receipt:** 03 Jul., 2013  
**Date of Test:** 04 Jul., to 15 Jul., 2013  
**Date of report issued:** 16 Jul., 2013  
**Test Result :** PASS \*

\* In the configuration tested, the EUT complied with the standards specified above.

Authorized Signature:



Bruce Zhang  
Laboratory Manager

This report details the results of the testing carried out on one sample. The results contained in this test report do not relate to other samples of the same product and does not permit the use of the CCIS product certification mark. The manufacturer should ensure that all products in series production are in conformity with the product sample detailed in this report.

This report may only be reproduced and distributed in full. If the product in this report is used in any configuration other than that detailed in the report, the manufacturer must ensure the new system complies with all relevant standards.

This document cannot be reproduced except in full, without prior written approval of the Company. Any unauthorized alteration, forgery or falsification of the content or appearance of this document is unlawful and offenders may be prosecuted to the fullest extent of the law. Unless otherwise stated the results shown in this test report refer only to the sample(s) tested and such sample(s) are retained for 90 days only.

## 2 Version

| Version No. | Date         | Description |
|-------------|--------------|-------------|
| 00          | 16 Jul.,2013 | Original    |
|             |              |             |
|             |              |             |
|             |              |             |
|             |              |             |

Prepared by:

*Sera*

Date:

16 Jul 2013

**Report Clerk**

Reviewed by:

*Wimer Zhang*

Date:

16 Jul 2013

**Project Engineer**

## 3 Contents

|  | Page      |
|--|-----------|
| <b>1 COVER PAGE</b> .....                        | <b>1</b>  |
| <b>2 VERSION</b> .....                           | <b>2</b>  |
| <b>3 CONTENTS</b> .....                          | <b>3</b>  |
| <b>4 TEST SUMMARY</b> .....                      | <b>4</b>  |
| <b>5 GENERAL INFORMATION</b> .....               | <b>5</b>  |
| 5.1 CLIENT INFORMATION.....                      | 5         |
| 5.2 GENERAL DESCRIPTION OF E.U.T. ....           | 5         |
| 5.3 TEST MODE.....                               | 7         |
| 5.4 DESCRIPTION OF SUPPORT UNITS.....            | 7         |
| 5.5 LABORATORY FACILITY.....                     | 7         |
| 5.6 LABORATORY LOCATION.....                     | 7         |
| 5.7 TEST INSTRUMENTS LIST.....                   | 8         |
| <b>6 TEST RESULTS AND MEASUREMENT DATA</b> ..... | <b>9</b>  |
| 6.1 ANTENNA REQUIREMENT:.....                    | 9         |
| 6.2 CONDUCTED EMISSIONS.....                     | 10        |
| 6.3 CONDUCTED OUTPUT POWER.....                  | 13        |
| 6.4 20dB OCCUPY BANDWIDTH.....                   | 17        |
| 6.5 CARRIER FREQUENCIES SEPARATION.....          | 21        |
| 6.6 HOPPING CHANNEL NUMBER.....                  | 26        |
| 6.7 DWELL TIME.....                              | 28        |
| 6.8 PSEUDORANDOM FREQUENCY HOPPING SEQUENCE..... | 32        |
| 6.9 BAND EDGE.....                               | 33        |
| 6.9.1 <i>Conducted Emission Method</i> .....     | 33        |
| 6.9.2 <i>Radiated Emission Method</i> .....      | 37        |
| 6.10 SPURIOUS EMISSION.....                      | 50        |
| 6.10.1 <i>Conducted Emission Method</i> .....    | 50        |
| 6.10.2 <i>Radiated Emission Method</i> .....     | 54        |
| <b>7 TEST SETUP PHOTO</b> .....                  | <b>61</b> |
| <b>8 EUT CONSTRUCTIONAL DETAILS</b> .....        | <b>63</b> |

## 4 Test Summary

| Test Item                        | Section in CFR 47 | Result |
|----------------------------------|-------------------|--------|
| Antenna Requirement              | 15.203/15.247 (c) | Pass   |
| AC Power Line Conducted Emission | 15.207            | Pass   |
| Conducted Peak Output Power      | 15.247 (b)(1)     | Pass   |
| 20dB Occupied Bandwidth          | 15.247 (a)(1)     | Pass   |
| Carrier Frequencies Separation   | 15.247 (a)(1)     | Pass   |
| Hopping Channel Number           | 15.247 (a)(1)     | Pass   |
| Dwell Time                       | 15.247 (a)(1)     | Pass   |
| Radiated Emission                | 15.205/15.209     | Pass   |
| Band Edge                        | 15.247(d)         | Pass   |

*Pass: The EUT complies with the essential requirements in the standard.*

## 5 General Information

### 5.1 Client Information

|                          |  |
|--------------------------|--|
| Applicant:               | Shenzhen Shuaixian Electronic Equipment Co.,Ltd.                                   |
| Address of Applicant:    | NO.10 Lane 3,Longxing Road, Dakang Long Village,<br>Henggang Town, Shenzhen, China |
| Manufacturer:            | Shenzhen Shuaixian Electronic Equipment Co.,Ltd.                                   |
| Address of Manufacturer: | NO.10 Lane 3,Longxing Road, Dakang Long Village,<br>Henggang Town, Shenzhen, China |

### 5.2 General Description of E.U.T.

|                        |                                    |
|------------------------|------------------------------------|
| Product Name:          | Bluetooth earphones                |
| Model No.:             | SX-971                             |
| Trade mark:            | Suicen                             |
| Operation Frequency:   | 2402MHz~2480MHz                    |
| Transfer rate:         | 1/2/3 Mbits/s                      |
| Number of channel:     | 79                                 |
| Modulation type:       | GFSK, $\pi/4$ -DQPSK, 8DPSK        |
| Modulation technology: | FHSS                               |
| Antenna Type:          | Internal Antenna                   |
| Antenna gain:          | 0dBi                               |
| Power supply:          | Rechargeable Li-ion Battery DC3.7V |

| Operation Frequency each of channel for GFSK, $\pi/4$ -DQPSK, 8DPSK |           |         |           |         |           |         |           |
|---|-----------|---------|-----------|---------|-----------|---------|-----------|
| Channel   | Frequency | Channel | Frequency | Channel | Frequency | Channel | Frequency |
| 0   | 2402MHz   | 20      | 2422MHz   | 40      | 2442MHz   | 60      | 2462MHz   |
| 1   | 2403MHz   | 21      | 2423MHz   | 41      | 2443MHz   | 61      | 2463MHz   |
| 2   | 2404MHz   | 22      | 2424MHz   | 42      | 2444MHz   | 62      | 2464MHz   |
| 3   | 2405MHz   | 23      | 2425MHz   | 43      | 2445MHz   | 63      | 2465MHz   |
| 4   | 2406MHz   | 24      | 2426MHz   | 44      | 2446MHz   | 64      | 2466MHz   |
| 5   | 2407MHz   | 25      | 2427MHz   | 45      | 2447MHz   | 65      | 2467MHz   |
| 6   | 2408MHz   | 26      | 2428MHz   | 46      | 2448MHz   | 66      | 2468MHz   |
| 7   | 2409MHz   | 27      | 2429MHz   | 47      | 2449MHz   | 67      | 2469MHz   |
| 8   | 2410MHz   | 28      | 2430MHz   | 48      | 2450MHz   | 68      | 2470MHz   |
| 9   | 2411MHz   | 29      | 2431MHz   | 49      | 2451MHz   | 69      | 2471MHz   |
| 10  | 2412MHz   | 30      | 2432MHz   | 50      | 2452MHz   | 70      | 2472MHz   |
| 11  | 2413MHz   | 31      | 2433MHz   | 51      | 2453MHz   | 71      | 2473MHz   |
| 12  | 2414MHz   | 32      | 2434MHz   | 52      | 2454MHz   | 72      | 2474MHz   |
| 13  | 2415MHz   | 33      | 2435MHz   | 53      | 2455MHz   | 73      | 2475MHz   |
| 14  | 2416MHz   | 34      | 2436MHz   | 54      | 2456MHz   | 74      | 2476MHz   |
| 15  | 2417MHz   | 35      | 2437MHz   | 55      | 2457MHz   | 75      | 2477MHz   |
| 16  | 2418MHz   | 36      | 2438MHz   | 56      | 2458MHz   | 76      | 2478MHz   |
| 17  | 2419MHz   | 37      | 2439MHz   | 57      | 2459MHz   | 77      | 2479MHz   |
| 18  | 2420MHz   | 38      | 2440MHz   | 58      | 2460MHz   | 78      | 2480MHz   |
| 19  | 2421MHz   | 39      | 2441MHz   | 59      | 2461MHz   |         |           |

Remark: Channel 0, 39 & 78 selected for GFSK,  $\pi/4$ -DQPSK and 8DPSK.

### 5.3 Test mode

|  |  |
|--|--|
| Transmitting mode:   | Keep the EUT in transmitting mode with worst case data rate. |
| Remark   | GFSK (1 Mbps) is the worst case mode.                        |
| <p>The sample was placed 0.8m above the ground plane of 3m chamber*. Measurements in both horizontal and vertical polarities were performed. During the test, each emission was maximized by: having the EUT continuously working with a fresh battery, investigated all operating modes, rotated about all 3 axis (X, Y &amp; Z) and considered typical configuration to obtain worst position, manipulating interconnecting cables, rotating the turntable, varying antenna height from 1m to 4m in both horizontal and vertical polarizations. The emissions worst-case are shown in Test Results of the following pages.</p> |  |

### 5.4 Description of Support Units

| Manufacturer | Description | Model       | Serial Number | FCC ID/DoC |
|--------------|-------------|-------------|---------------|------------|
| DELL         | PC          | OPTIPLEX745 | N/A           | DoC        |
| DELL         | MONITOR     | E178FPC     | N/A           | DoC        |
| DELL         | KEYBOARD    | SK-8115     | N/A           | DoC        |
| DELL         | MOUSE       | MOC5UO      | N/A           | DoC        |

### 5.5 Laboratory Facility

|  |
|--|
| <p>The test facility is recognized, certified, or accredited by the following organizations:</p> <ul style="list-style-type: none"> <li>● <b>FCC - Registration No.: 817957</b><br/>Shenzhen Zhongjian Nanfang Testing Co., Ltd. EMC Laboratory has been registered and fully described in a report filed with the (FCC) Federal Communications Commission. The acceptance letter from the FCC is maintained in our files. Registration 817957, February 27, 2012.</li> <li>● <b>IC - Registration No.: 10106A-1</b><br/>The 3m Semi-anechoic chamber of Shenzhen Zhongjian Nanfang Testing Co., Ltd. has been Registered by Certification and Engineering Bureau of Industry Canada for radio equipment testing with Registration No.: 10106A-1.</li> <li>● <b>CNAS - Registration No.: CNAS L6048</b><br/>Shenzhen Zhongjian Nanfang Testing Co., Ltd. is accredited to ISO/IEC 17025:2005 General Requirements for the Competence of Testing and Calibration laboratories for the competence of testing. The Registration No. is CNAS L6048.</li> </ul> |
|--|

### 5.6 Laboratory Location

|  |
|--|
| <p>Shenzhen Zhongjian Nanfang Testing Co., Ltd.<br/>Address: No.B-C, 1/F., Building 2, Laodong No.2 Industrial Park, Xixiang Road,<br/>Bao'an District, Shenzhen, Guangdong, China<br/>Tel: 0755-23118282<br/>Fax: 0755-23116366</p> |
|--|

## 5.7 Test Instruments list

| Radiated Emission: |                                      |                                   |                             |               |                      |                          |
|--------------------|--------------------------------------|-----------------------------------|-----------------------------|---------------|----------------------|--------------------------|
| Item               | Test Equipment                       | Manufacturer                      | Model No.                   | Inventory No. | Cal. Date (mm-dd-yy) | Cal. Due date (mm-dd-yy) |
| 1                  | 3m Semi- Anechoic Chamber            | SAEMC                             | 9(L)*6(W)* 6(H)             | CCIS0001      | June 09 2013         | June 08 2014             |
| 2                  | BiConiLog Antenna                    | SCHWARZBECK<br>MESS-ELEKTRONIK    | VULB9163                    | CCIS0005      | May 25 2013          | May 24 2014              |
| 3                  | Double -ridged waveguide horn        | SCHWARZBECK<br>MESS-ELEKTRONIK    | BBHA9120D                   | CCIS0006      | May 25 2013          | May 24 2014              |
| 4                  | EMI Test Software                    | AUDIX                             | E3                          | N/A           | N/A                  | N/A                      |
| 5                  | Coaxial Cable                        | CCIS                              | N/A                         | CCIS0016      | Apr. 01 2013         | Mar. 31 2014             |
| 6                  | Coaxial Cable                        | CCIS                              | N/A                         | CCIS0017      | Apr. 01 2013         | Mar. 31 2014             |
| 7                  | Coaxial cable                        | CCIS                              | N/A                         | CCIS0018      | Apr. 01 2013         | Mar. 31 2014             |
| 8                  | Coaxial Cable                        | CCIS                              | N/A                         | CCIS0019      | Apr. 01 2013         | Mar. 31 2014             |
| 9                  | Coaxial Cable                        | CCIS                              | N/A                         | CCIS0087      | Apr. 01 2013         | Mar. 31 2014             |
| 10                 | Amplifier(10kHz-1.3GHz)              | HP                                | 8447D                       | CCIS0003      | Apr. 01 2013         | Mar. 31 2014             |
| 11                 | Amplifier(1GHz-18GHz)                | Compliance Direction Systems Inc. | PAP-1G18                    | CCIS0011      | June 09 2013         | June 08 2014             |
| 12                 | Pre-amplifier (18-26GHz)             | Rohde & Schwarz                   | AFS33-18002<br>650-30-8P-44 | GTS218        | Apr. 01 2013         | Mar. 31 2014             |
| 13                 | Horn Antenna                         | ETS-LINDGREN                      | 3160                        | GTS217        | Mar. 30 2013         | Mar. 29 2014             |
| 14                 | Printer                              | HP                                | HP LaserJet P1007           | N/A           | N/A                  | N/A                      |
| 15                 | Positioning Controller               | UC                                | UC3000                      | CCIS0015      | N/A                  | N/A                      |
| 16                 | Spectrum analyzer 9k-30GHz           | Rohde & Schwarz                   | FSP                         | CCIS0023      | May. 25 2013         | May. 24 2014             |
| 17                 | EMI Test Receiver                    | Rohde & Schwarz                   | ESPI                        | CCIS0022      | Apr 01 2013          | Mar. 31 2014             |
| 18                 | Loop antenna                         | Laplace instrument                | RF300                       | EMC0701       | Aug. 12 2012         | Aug. 11 2013             |
| 19                 | Universal radio communication tester | Rhode & Schwarz                   | CMU200                      | CCIS0069      | May. 25 2013         | May. 24 2014             |
| 20                 | Signal Analyzer                      | Rohde & Schwarz                   | FSIQ3                       | CCIS0088      | May. 25 2013         | May. 24 2014             |

| Conducted Emission: |                   |                    |                       |               |                      |                          |
|---------------------|-------------------|--------------------|-----------------------|---------------|----------------------|--------------------------|
| Item                | Test Equipment    | Manufacturer       | Model No.             | Inventory No. | Cal. Date (mm-dd-yy) | Cal. Due date (mm-dd-yy) |
| 1                   | Shielding Room    | ZhongShuo Electron | 11.0(L)x4.0(W)x3.0(H) | CCIS0061      | June 09 2013         | June 08 2014             |
| 2                   | EMI Test Receiver | Rohde & Schwarz    | ESCI                  | CCIS0002      | May 25 2013          | May 24 2014              |
| 3                   | LISN              | CHASE              | MN2050D               | CCIS0074      | Apr 01 2013          | Mar. 31 2014             |
| 4                   | Coaxial Cable     | CCIS               | N/A                   | CCIS0086      | Apr. 01 2013         | Mar. 31 2014             |
| 5                   | EMI Test Software | AUDIX              | E3                    | N/A           | N/A                  | N/A                      |



## 6 Test results and Measurement Data

### 6.1 Antenna requirement:

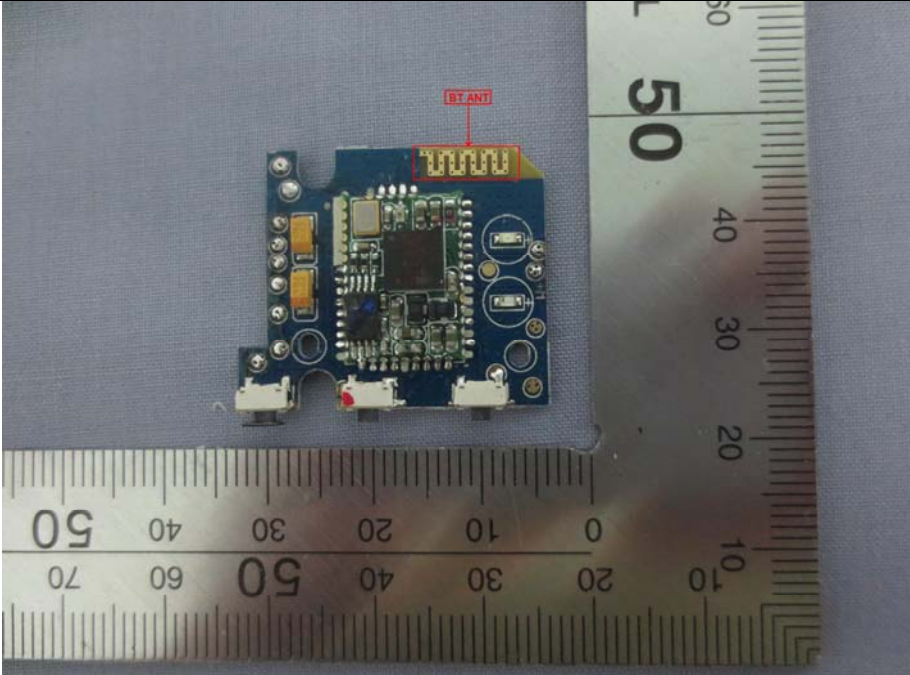
|  |                                     |
|--|-------------------------------------|
| <b>Standard requirement:</b>   | FCC Part15 C Section 15.203 /247(c) |
| <p><i>15.203 requirement:</i><br/> <i>An intentional radiator shall be designed to ensure that no antenna other than that furnished by the responsible party shall be used with the device. The use of a permanently attached antenna or of an antenna that uses a unique coupling to the intentional radiator, the manufacturer may design the unit so that a broken antenna can be replaced by the user, but the use of a standard antenna jack or electrical connector is prohibited.</i></p> <p><i>15.247(c) (1)(i) requirement:</i><br/> <i>(i) Systems operating in the 2400-2483.5 MHz band that is used exclusively for fixed. Point-to-point operations may employ transmitting antennas with directional gain greater than 6dBi provided the maximum conducted output power of the intentional radiator is reduced by 1 dB for every 3 dB that the directional gain of the antenna exceeds 6dBi.</i></p> |                                     |
| <b>E.U.T Antenna:</b>  |                                     |
| <p><i>The Bluetooth antenna is an integral antenna which permanently attached, and the best case gain of the antenna is 0 dBi.</i></p>   |                                     |
|   |                                     |

## 6.2 Conducted Emissions

| Test Requirement:     | FCC Part15 C Section 15.207  |                       |              |  |            |         |          |           |           |       |    |    |      |    |    |
|-----------------------|--|-----------------------|--------------|--|------------|---------|----------|-----------|-----------|-------|----|----|------|----|----|
| Test Method:          | ANSI C63.4:2003  |                       |              |  |            |         |          |           |           |       |    |    |      |    |    |
| Test Frequency Range: | 150 kHz to 30 MHz  |                       |              |  |            |         |          |           |           |       |    |    |      |    |    |
| Class / Severity:     | Class B  |                       |              |  |            |         |          |           |           |       |    |    |      |    |    |
| Receiver setup:       | RBW=9 kHz, VBW=30 kHz, Sweep time=auto   |                       |              |  |            |         |          |           |           |       |    |    |      |    |    |
| Limit:                | <table border="1"> <thead> <tr> <th rowspan="2">Frequency range (MHz)</th> <th colspan="2">Limit (dBuV)</th> </tr> <tr> <th>Quasi-peak</th> <th>Average</th> </tr> </thead> <tbody> <tr> <td>0.15-0.5</td> <td>66 to 56*</td> <td>56 to 46*</td> </tr> <tr> <td>0.5-5</td> <td>56</td> <td>46</td> </tr> <tr> <td>5-30</td> <td>60</td> <td>50</td> </tr> </tbody> </table> <p>* Decreases with the logarithm of the frequency.</p>  | Frequency range (MHz) | Limit (dBuV) |  | Quasi-peak | Average | 0.15-0.5 | 66 to 56* | 56 to 46* | 0.5-5 | 56 | 46 | 5-30 | 60 | 50 |
| Frequency range (MHz) | Limit (dBuV)   |                       |              |  |            |         |          |           |           |       |    |    |      |    |    |
|                       | Quasi-peak   | Average               |              |  |            |         |          |           |           |       |    |    |      |    |    |
| 0.15-0.5              | 66 to 56*  | 56 to 46*             |              |  |            |         |          |           |           |       |    |    |      |    |    |
| 0.5-5                 | 56   | 46                    |              |  |            |         |          |           |           |       |    |    |      |    |    |
| 5-30                  | 60   | 50                    |              |  |            |         |          |           |           |       |    |    |      |    |    |
| Test setup:           | <p>Remark:<br/> E.U.T: Equipment Under Test<br/> LISN: Line Impedance Stabilization Network<br/> Test table height=0.6m</p>  |                       |              |  |            |         |          |           |           |       |    |    |      |    |    |
| Test procedure:       | <ol style="list-style-type: none"> <li>1. The E.U.T and simulators are connected to the main power through a line impedance stabilization network (L.I.S.N.). This provides a 50ohm/50uH coupling impedance for the measuring equipment.</li> <li>2. The peripheral devices are also connected to the main power through a LISN that provides a 50ohm/50uH coupling impedance with 50ohm termination. (Please refer to the block diagram of the test setup and photographs).</li> <li>3. Both sides of A.C. line are checked for maximum conducted interference. In order to find the maximum emission, the relative positions of equipment and all of the interface cables must be changed according to ANSI C63.4: 2003 on conducted measurement.</li> </ol> |                       |              |  |            |         |          |           |           |       |    |    |      |    |    |
| Test Instruments:     | Refer to section 5.7 for details   |                       |              |  |            |         |          |           |           |       |    |    |      |    |    |
| Test mode:            | Bluetooth (Continuous transmitting) mode   |                       |              |  |            |         |          |           |           |       |    |    |      |    |    |
| Test results:         | Pass   |                       |              |  |            |         |          |           |           |       |    |    |      |    |    |

### Measurement Data

Line:

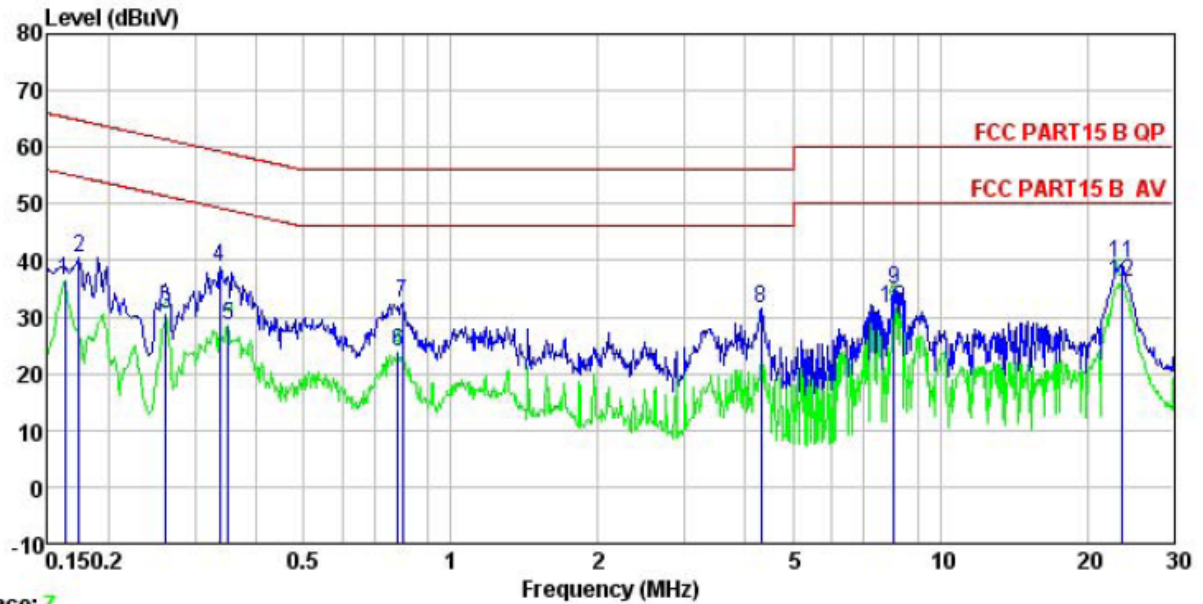

Trace: 7

Site : CCIS Conducted test Site  
 Condition : FCC PART15 B QP LISN LINE  
 Job. no : 201RF  
 EUT : Stereo Bluetooth Headphone  
 Model : SX-971  
 Test Mode : BT TX mode  
 Power Rating : AC 120V/60Hz  
 Environment : Temp: 23 °C Humi:56% Atmos:101KPa  
 Test Engineer: Winner  
 Remark :

|    | Read Freq | Level | LISN Factor | Cable Loss | Level | Limit Line | Over Limit | Remark  |
|----|-----------|-------|-------------|------------|-------|------------|------------|---------|
|    | MHz       | dBuV  | dB          | dB         | dBuV  | dBuV       | dB         |         |
| 1  | 0.162     | 25.41 | 10.24       | 0.78       | 36.43 | 55.34      | -18.91     | Average |
| 2  | 0.174     | 29.41 | 10.23       | 0.77       | 40.41 | 64.77      | -24.36     | QP      |
| 3  | 0.262     | 19.51 | 10.24       | 0.75       | 30.50 | 51.38      | -20.88     | Average |
| 4  | 0.337     | 27.78 | 10.27       | 0.73       | 38.78 | 59.27      | -20.49     | QP      |
| 5  | 0.350     | 17.56 | 10.27       | 0.73       | 28.56 | 48.96      | -20.40     | Average |
| 6  | 0.779     | 13.04 | 10.19       | 0.80       | 24.03 | 46.00      | -21.97     | Average |
| 7  | 0.796     | 21.66 | 10.19       | 0.81       | 32.66 | 56.00      | -23.34     | QP      |
| 8  | 4.315     | 20.27 | 10.29       | 0.88       | 31.44 | 56.00      | -24.56     | QP      |
| 9  | 8.062     | 23.76 | 10.26       | 0.85       | 34.87 | 60.00      | -25.13     | QP      |
| 10 | 8.062     | 20.37 | 10.26       | 0.85       | 31.48 | 50.00      | -18.52     | Average |
| 11 | 23.511    | 28.09 | 10.49       | 0.89       | 39.47 | 60.00      | -20.53     | QP      |
| 12 | 23.511    | 24.72 | 10.49       | 0.89       | 36.10 | 50.00      | -13.90     | Average |

Neutral:

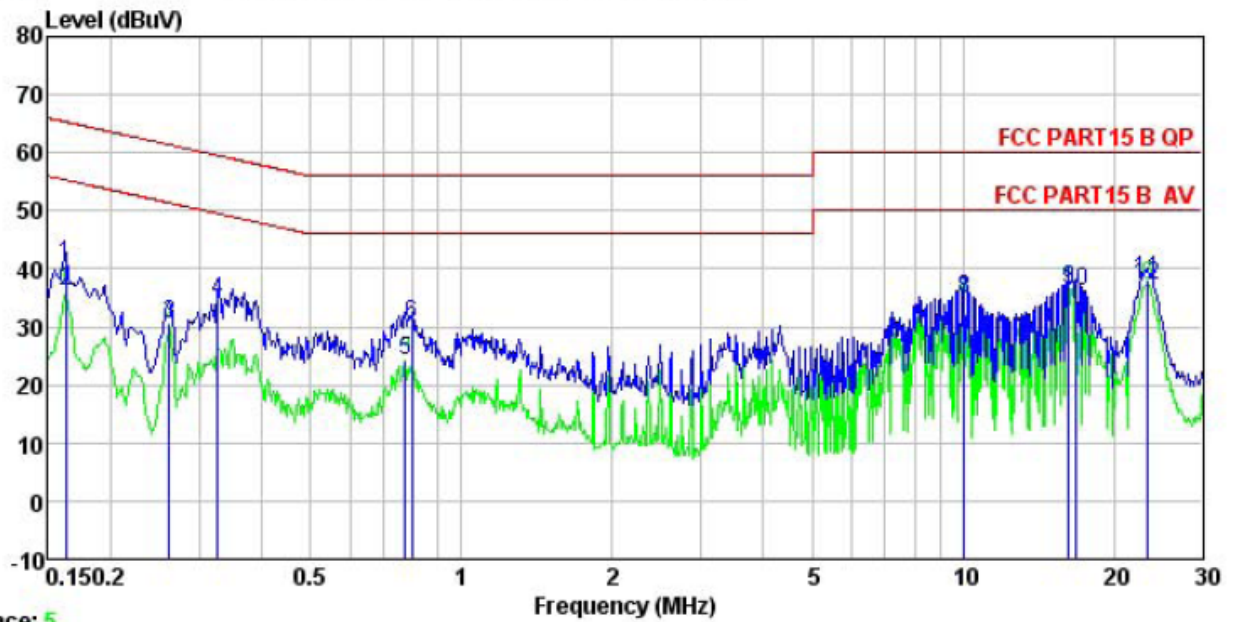

Trace: 5

Site : CCIS Conducted test Site  
 Condition : FCC PART15 B QP LISN NEUTRAL  
 Job. no : 201RF  
 EUT : Stereo Bluetooth Headphone  
 Model : SX-971  
 Test Mode : BT TX mode  
 Power Rating : AC 120V/60Hz  
 Environment : Temp: 23 °C Humi:56% Atmos:101KPa  
 Test Engineer: Winner  
 Remark :

|      | Read   | LISN   | Cable | Level | Limit | Over  |                |
|------|--------|--------|-------|-------|-------|-------|----------------|
| Freq | Level  | Factor | Loss  | Level | Line  | Limit | Remark         |
| MHz  | dBuV   | dB     | dB    | dBuV  | dBuV  | dB    |                |
| 1    | 0.162  | 29.62  | 10.26 | 0.78  | 40.66 | 65.34 | -24.68 QP      |
| 2    | 0.162  | 25.09  | 10.26 | 0.78  | 36.13 | 55.34 | -19.21 Average |
| 3    | 0.262  | 19.46  | 10.24 | 0.75  | 30.45 | 51.38 | -20.93 Average |
| 4    | 0.327  | 23.61  | 10.25 | 0.73  | 34.59 | 59.53 | -24.94 QP      |
| 5    | 0.771  | 13.17  | 10.17 | 0.80  | 24.14 | 46.00 | -21.86 Average |
| 6    | 0.796  | 19.67  | 10.17 | 0.81  | 30.65 | 56.00 | -25.35 QP      |
| 7    | 10.072 | 23.24  | 10.22 | 0.94  | 34.40 | 60.00 | -25.60 QP      |
| 8    | 10.072 | 23.61  | 10.22 | 0.94  | 34.77 | 50.00 | -15.23 Average |
| 9    | 16.226 | 25.32  | 10.26 | 0.91  | 36.49 | 50.00 | -13.51 Average |
| 10   | 16.839 | 24.83  | 10.27 | 0.91  | 36.01 | 60.00 | -23.99 QP      |
| 11   | 23.387 | 26.64  | 10.48 | 0.89  | 38.01 | 60.00 | -21.99 QP      |
| 12   | 23.387 | 25.77  | 10.48 | 0.89  | 37.14 | 50.00 | -12.86 Average |

Notes:

1. An initial pre-scan was performed on the line and neutral lines with peak detector.
2. Quasi-Peak and Average measurement were performed at the frequencies with maximized peak emission.
3. Final Level = Receiver Read level + LISN Factor + Cable Loss

### 6.3 Conducted Output Power

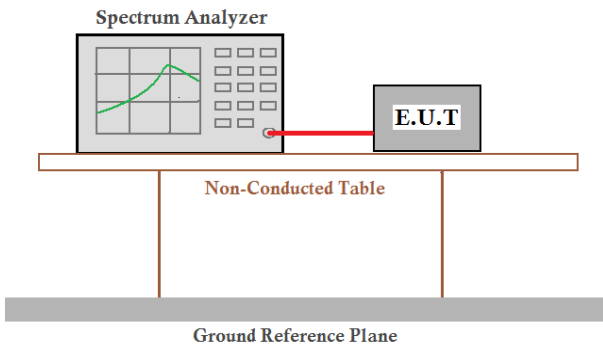
|                   |  |
|-------------------|--|
| Test Requirement: | FCC Part15 C Section 15.247 (b)(3)   |
| Test Method:      | ANSI C63.4:2003 and DA00-705   |
| Receiver setup:   | RBW=1MHz, VBW=3MHz, Detector=Peak (If 20dB BW ≤ 1 MHz)<br>RBW=3MHz, VBW=10MHz, Detector=Peak (If 20dB BW > 1 MHz and < 3MHz)   |
| Limit:            | 125 mW(21 dBm)   |
| Test setup:       |  <p>The diagram illustrates the test setup. A Spectrum Analyzer is connected via a red cable to an E.U.T. (Equipment Under Test). Both are placed on a Non-Conducted Table. Below the table is a Ground Reference Plane.</p> |
| Test Instruments: | Refer to section 5.7 for details   |
| Test mode:        | Non-hopping mode   |
| Test results:     | Pass   |

### Measurement Data

| GFSK mode           |                         |             |        |
|---------------------|-------------------------|-------------|--------|
| Test channel        | Peak Output Power (dBm) | Limit (dBm) | Result |
| Lowest              | 3.42                    | 21.00       | Pass   |
| Middle              | 4.96                    | 21.00       | Pass   |
| Highest             | 4.88                    | 21.00       | Pass   |
| $\pi/4$ -DQPSK mode |                         |             |        |
| Test channel        | Peak Output Power (dBm) | Limit (dBm) | Result |
| Lowest              | 1.25                    | 21.00       | Pass   |
| Middle              | 3.18                    | 21.00       | Pass   |
| Highest             | 3.11                    | 21.00       | Pass   |
| 8DPSK mode          |                         |             |        |
| Test channel        | Peak Output Power (dBm) | Limit (dBm) | Result |
| Lowest              | 1.86                    | 21.00       | Pass   |
| Middle              | 3.69                    | 21.00       | Pass   |
| Highest             | 3.60                    | 21.00       | Pass   |

Test plot as follows:

|                  |      |
|------------------|------|
| Modulation mode: | GFSK |
|------------------|------|

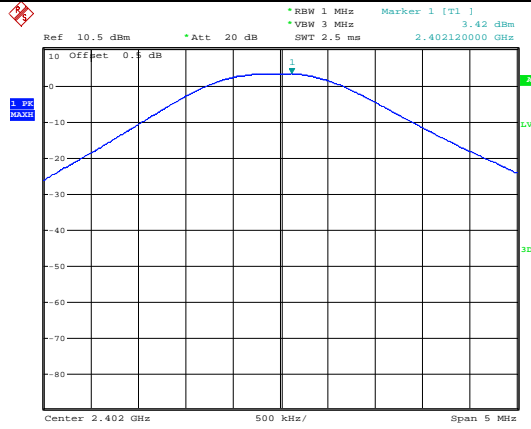

Date: 4.JUL.2013 11:56:18

### Lowest channel

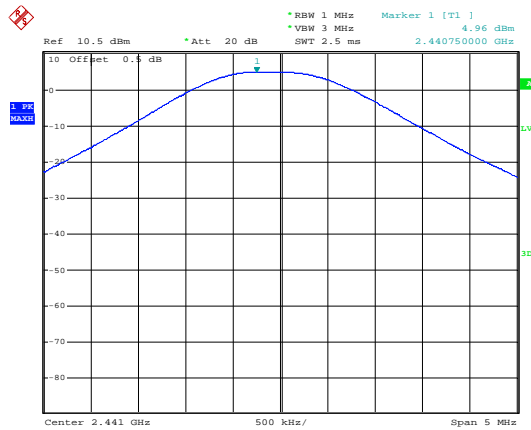

Date: 4.JUL.2013 11:57:54

### Middle channel

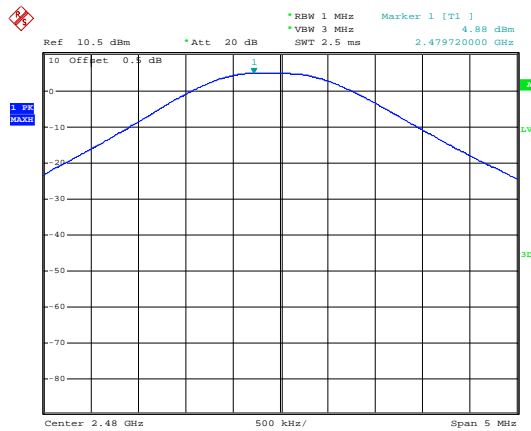

Date: 4.JUL.2013 11:59:19

### Highest channel

Modulation mode:  $\pi/4$ -DQPSK

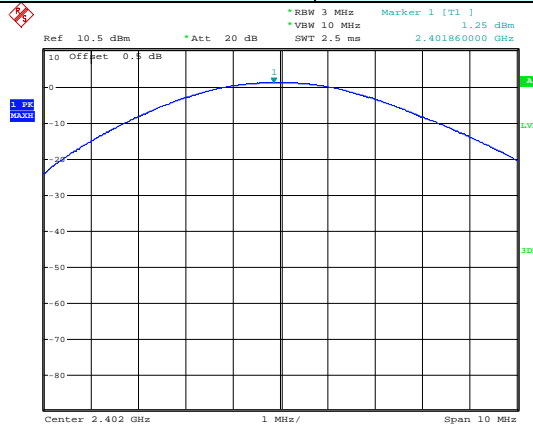

Date: 4.JUL.2013 12:03:35

Lowest channel

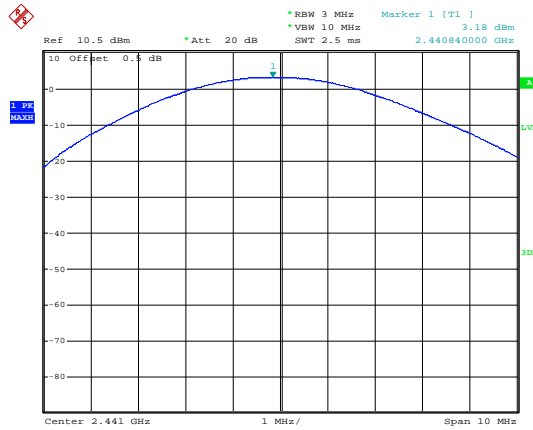

Date: 4.JUL.2013 12:02:28

Middle channel

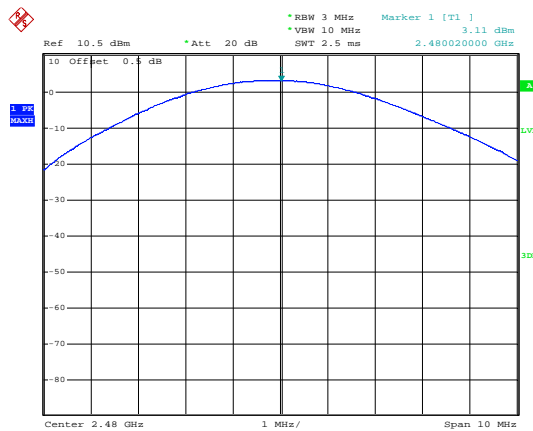

Date: 4.JUL.2013 12:01:35

Highest channel

Modulation mode: 8DPSK

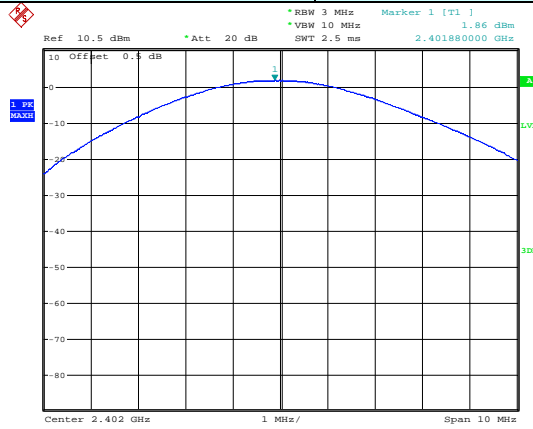

Date: 4.JUL.2013 12:04:36

### Lowest channel

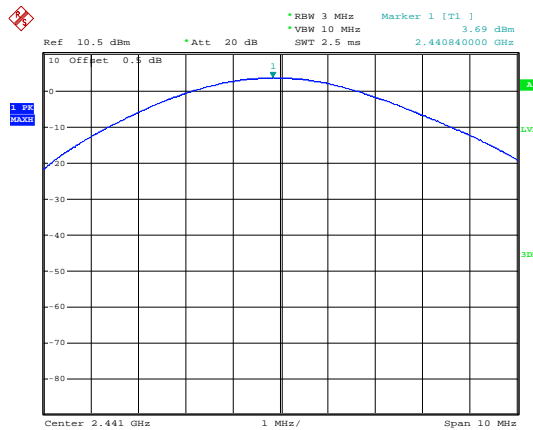

Date: 4.JUL.2013 12:05:46

### Middle channel

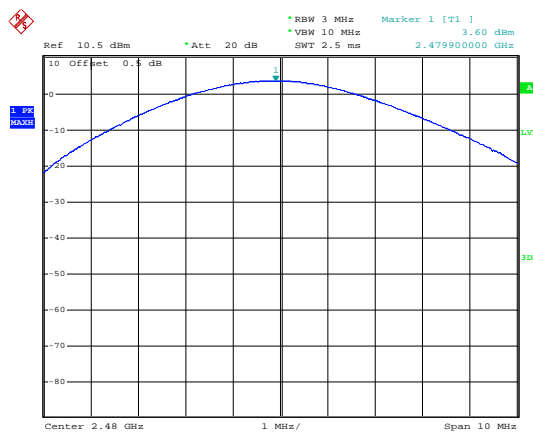

Date: 4.JUL.2013 12:06:42

### Highest channel

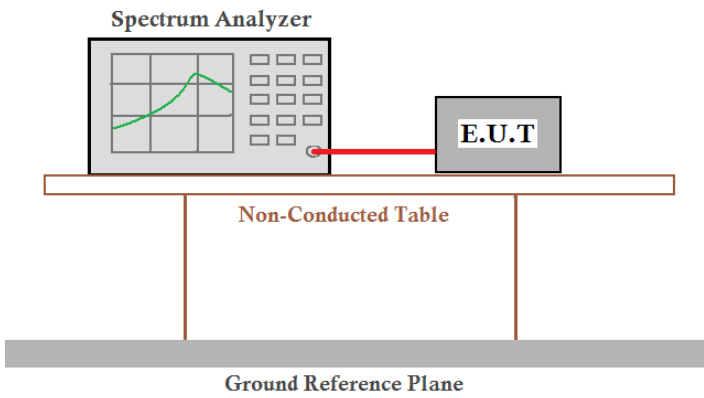

## 6.4 20dB Occupy Bandwidth

|                   |   |
|-------------------|---|
| Test Requirement: | FCC Part15 C Section 15.247 (a)(1)  |
| Test Method:      | ANSI C63.4:2003 and DA00-705  |
| Receiver setup:   | RBW=30 kHz, VBW=100 kHz, detector=Peak  |
| Limit:            | NA  |
| Test setup:       |  <p>The diagram shows a Spectrum Analyzer and an E.U.T. (Equipment Under Test) connected by a red cable. They are positioned on a table labeled 'Non-Conducted Table'. Below the table is a 'Ground Reference Plane'.</p> |
| Test Instruments: | Refer to section 5.7 for details  |
| Test mode:        | Non-hopping mode  |
| Test results:     | Pass  |

### Measurement Data

| Test channel | 20dB Occupy Bandwidth (kHz) |                |       |
|--------------|-----------------------------|----------------|-------|
|              | GFSK                        | $\pi/4$ -DQPSK | 8DPSK |
| Lowest       | 952                         | 1228           | 1220  |
| Middle       | 928                         | 1228           | 1220  |
| Highest      | 928                         | 1228           | 1220  |

Test plot as follows:

Modulation mode: **GFSK**

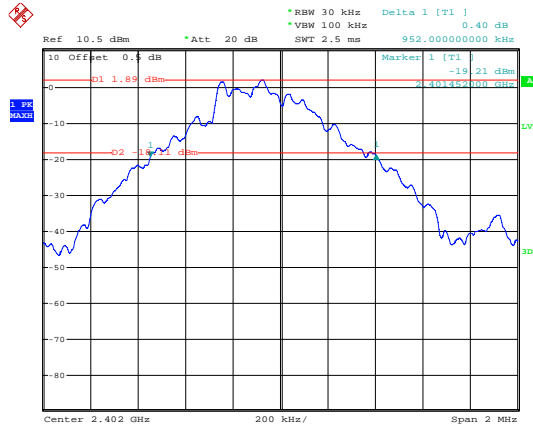

Date: 4.JUL.2013 12:31:16

Lowest channel

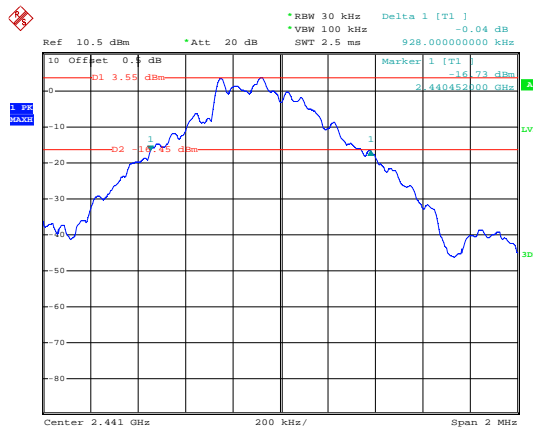

Date: 4.JUL.2013 12:25:24

Middle channel

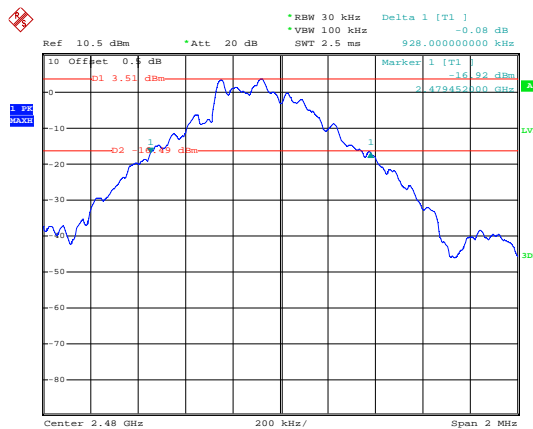

Date: 4.JUL.2013 12:33:33

Highest channel

Modulation mode: π/4-DQPSK

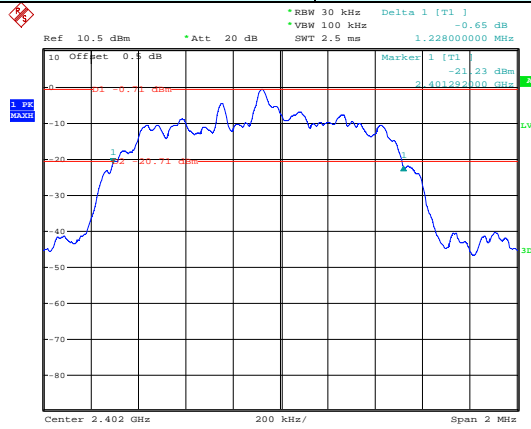

Date: 4.JUL.2013 12:17:22

### Lowest channel

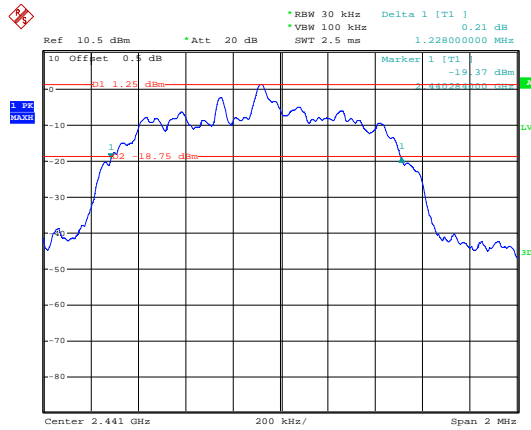

Date: 4.JUL.2013 12:20:07

### Middle channel



Date: 4.JUL.2013 12:21:48

### Highest channel

Modulation mode: 8DPSK

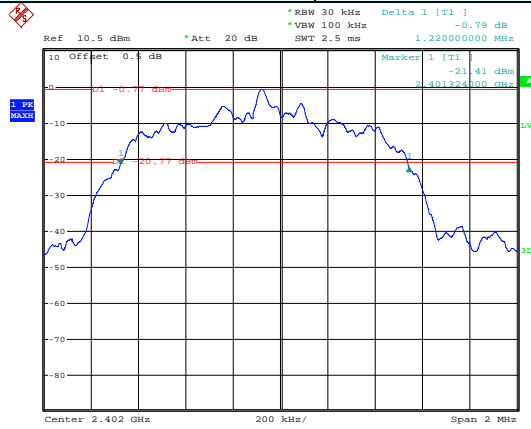

Date: 4.JUL.2013 12:14:44

### Lowest channel

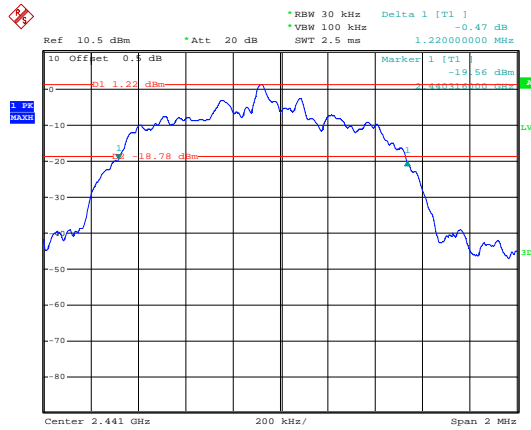

Date: 4.JUL.2013 12:12:59

### Middle channel

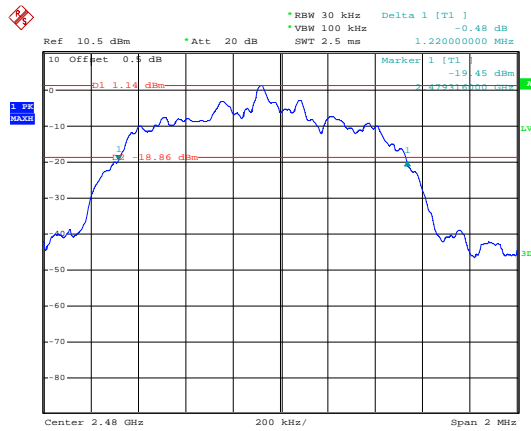

Date: 4.JUL.2013 12:11:11

### Highest channel

## 6.5 Carrier Frequencies Separation

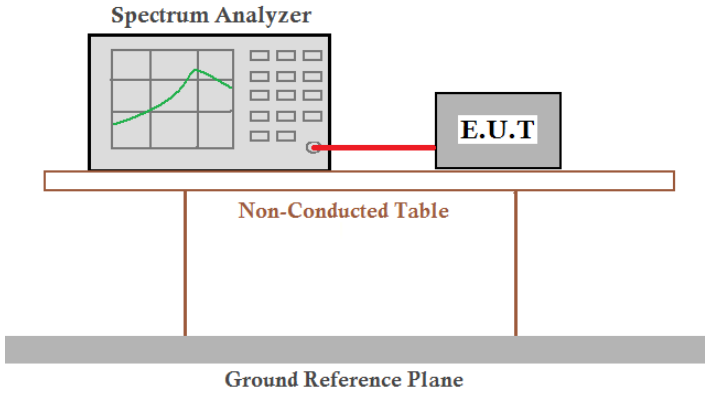
|                   |   |
|-------------------|---|
| Test Requirement: | FCC Part15 C Section 15.247 (a)(1)  |
| Test Method:      | ANSI C63.4:2003 and DA00-705  |
| Receiver setup:   | RBW=100 kHz, VBW=300 kHz, detector=Peak   |
| Limit:            | 0.025MHz or 2/3 of the 20dB bandwidth (whichever is greater)  |
| Test setup:       |  <p>The diagram illustrates the test setup. A Spectrum Analyzer is connected to an E.U.T. (Equipment Under Test) via a red cable. Both are placed on a Non-Conducted Table, which is positioned above a Ground Reference Plane.</p> |
| Test Instruments: | Refer to section 5.7 for details  |
| Test mode:        | Hopping mode  |
| Test results:     | Pass  |

### Measurement Data

| GFSK mode           |                                      |             |        |
|---------------------|--------------------------------------|-------------|--------|
| Test channel        | Carrier Frequencies Separation (kHz) | Limit (kHz) | Result |
| Lowest              | 1004                                 | 634.667     | Pass   |
| Middle              | 1008                                 | 634.667     | Pass   |
| Highest             | 1004                                 | 634.667     | Pass   |
| $\pi/4$ -DQPSK mode |                                      |             |        |
| Test channel        | Carrier Frequencies Separation (kHz) | Limit (kHz) | Result |
| Lowest              | 1004                                 | 818.667     | Pass   |
| Middle              | 1004                                 | 818.667     | Pass   |
| Highest             | 1004                                 | 818.667     | Pass   |
| 8DPSK mode          |                                      |             |        |
| Test channel        | Carrier Frequencies Separation (kHz) | Limit (kHz) | Result |
| Lowest              | 1004                                 | 813.333     | Pass   |
| Middle              | 1004                                 | 813.333     | Pass   |
| Highest             | 1004                                 | 813.333     | Pass   |

Note: According to section 6.4

| Mode           | 20dB bandwidth (kHz)<br>(worse case) | Limit (kHz)<br>(Carrier Frequencies Separation) |
|----------------|--------------------------------------|---|
| GFSK           | 952                                  | 634.667   |
| $\pi/4$ -DQPSK | 1228                                 | 818.667   |
| 8DPSK          | 1220                                 | 813.333   |

Test plot as follows:

Modulation mode: **GFSK**

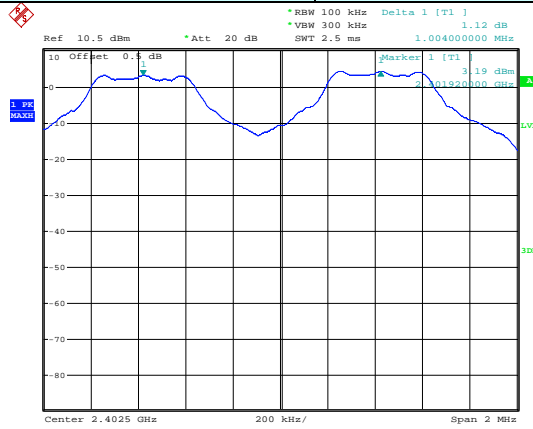

Date: 4.JUL.2013 14:03:33

Lowest channel

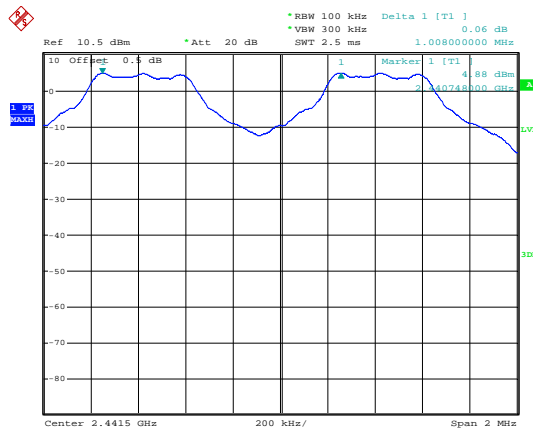

Date: 4.JUL.2013 14:05:44

Middle channel

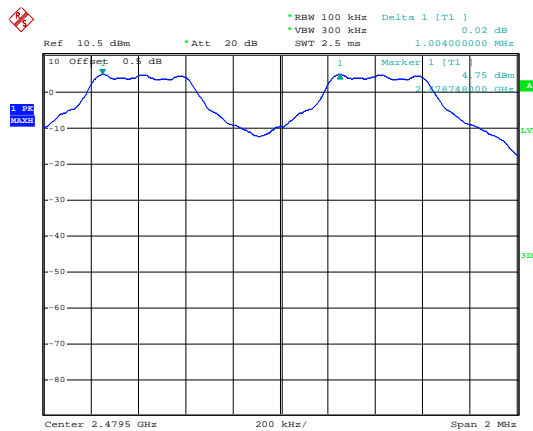

Date: 4.JUL.2013 14:08:19

Highest channel

Modulation mode:  $\pi/4$ -DQPSK

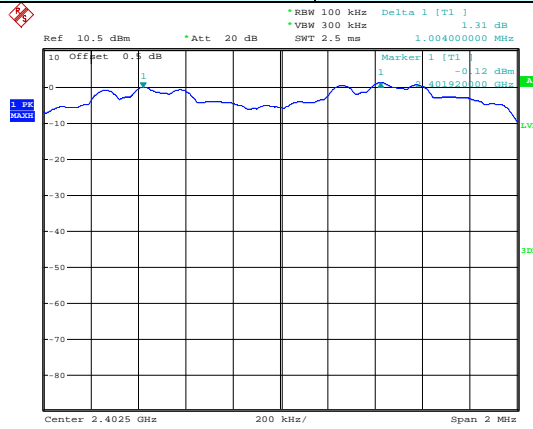

Date: 4.JUL.2013 14:18:47

### Lowest channel

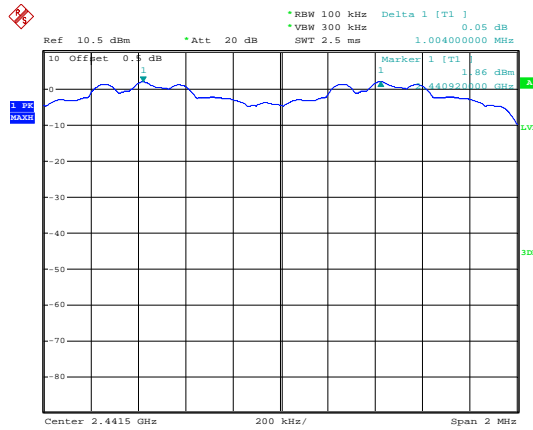

Date: 4.JUL.2013 14:15:02

### Middle channel

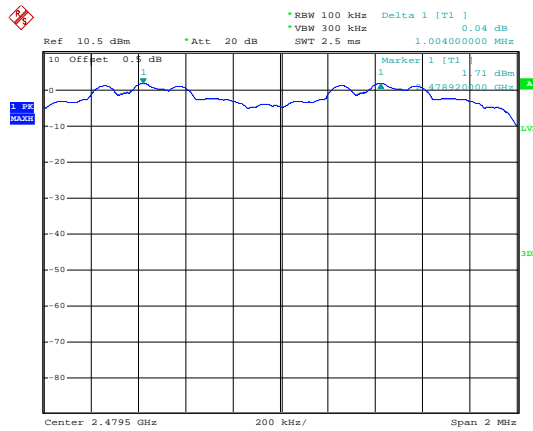

Date: 4.JUL.2013 14:10:09

### Highest channel



Modulation mode: 8DPSK

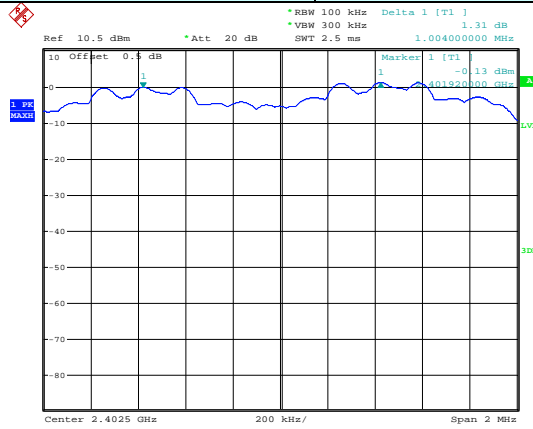

Date: 4.JUL.2013 14:20:45

### Lowest channel

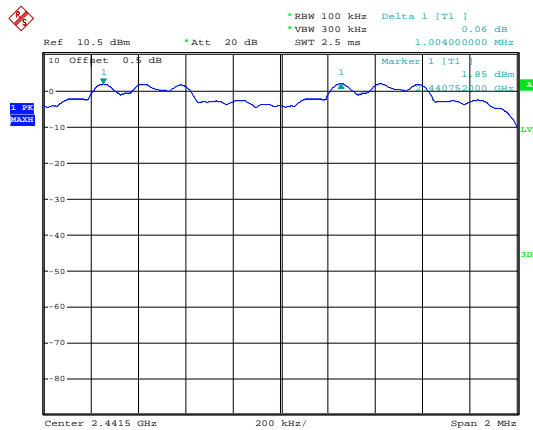

Date: 4.JUL.2013 14:23:03

### Middle channel

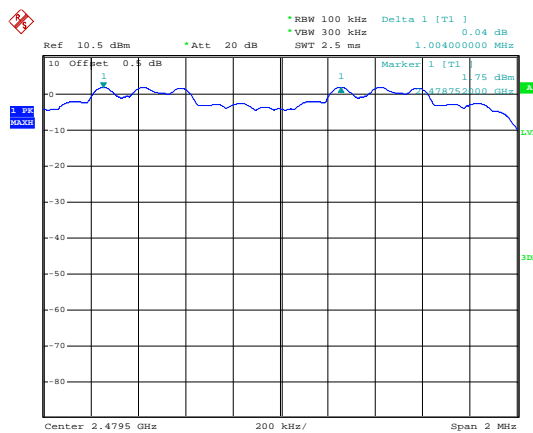

Date: 4.JUL.2013 14:27:10

### Highest channel

## 6.6 Hopping Channel Number

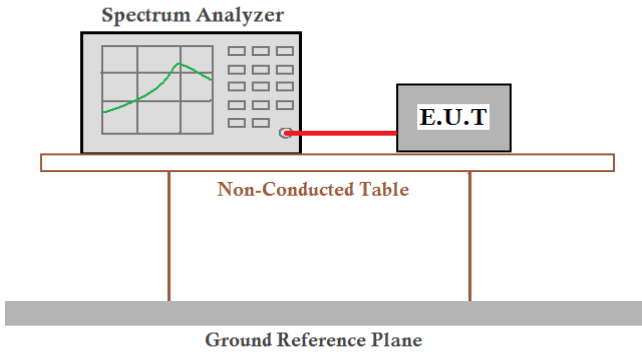
|                   |  |
|-------------------|--|
| Test Requirement: | FCC Part15 C Section 15.247 (a)(1)   |
| Test Method:      | ANSI C63.4:2003 and DA00-705   |
| Receiver setup:   | RBW=100 kHz, VBW=300 kHz, Frequency range=2400MHz-2483.5MHz, Detector=Peak   |
| Limit:            | 15 channels  |
| Test setup:       |  <p>The diagram illustrates the test setup. A Spectrum Analyzer is connected via a red cable to an E.U.T. (Equipment Under Test). Both are placed on a Non-Conducted Table. Below the table is a Ground Reference Plane.</p> |
| Test Instruments: | Refer to section 5.7 for details   |
| Test mode:        | Hopping mode   |
| Test results:     | Pass   |

### Measurement Data:

| Mode                        | Hopping channel numbers | Limit | Result |
|-----------------------------|-------------------------|-------|--------|
| GFSK, $\pi/4$ -DQPSK, 8DPSK | 79                      | 15    | Pass   |

### GFSK

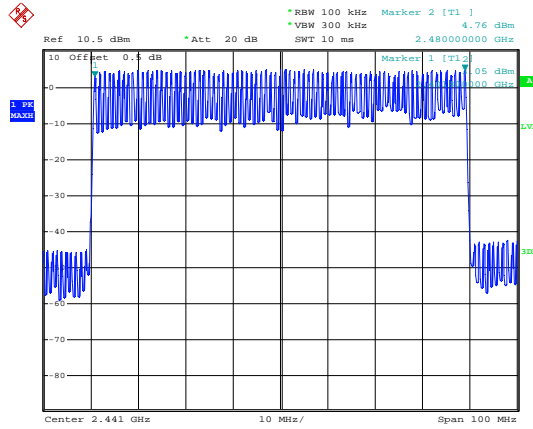

Date: 4.JUL.2013 14:43:13

### $\pi/4$ -DQPSK

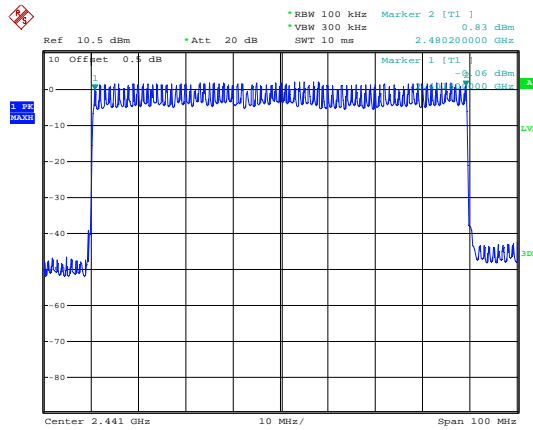

Date: 4.JUL.2013 14:40:53

### 8DPSK

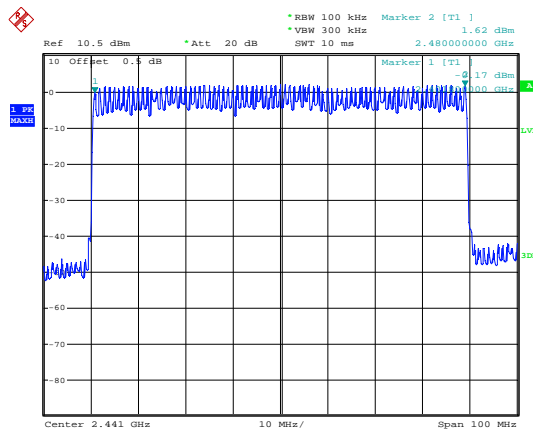

Date: 4.JUL.2013 14:35:52

## 6.7 Dwell Time

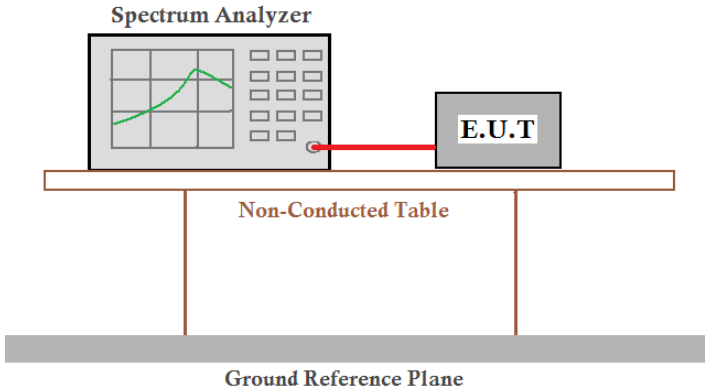
|                   |  |
|-------------------|--|
| Test Requirement: | FCC Part15 C Section 15.247 (a)(1)   |
| Test Method:      | ANSI C63.4:2003 and KDB DA00-705   |
| Receiver setup:   | RBW=1 MHz, VBW=1 MHz, Span=0 Hz, Detector=Peak   |
| Limit:            | 0.4 Second   |
| Test setup:       |  <p>The diagram illustrates the test setup. A Spectrum Analyzer is connected via a red cable to an E.U.T. (Equipment Under Test). Both are placed on a Non-Conducted Table. Below the table is a Ground Reference Plane.</p> |
| Test Instruments: | Refer to section 5.7 for details   |
| Test mode:        | Hopping mode   |
| Test results:     | Pass   |

### Measurement Data (Worse case)

| Mode           | Packet | Dwell time (second) | Limit (second) | Result |
|----------------|--------|---------------------|----------------|--------|
| GFSK           | DH1    | 0.14336             | 0.4            | Pass   |
|                | DH3    | 0.27648             |                |        |
|                | DH5    | 0.32085             |                |        |
| $\pi/4$ -DQPSK | 2-DH1  | 0.14528             | 0.4            | Pass   |
|                | 2-DH3  | 0.27552             |                |        |
|                | 2-DH5  | 0.32085             |                |        |
| 8DPSK          | 3-DH1  | 0.14720             | 0.4            | Pass   |
|                | 3-DH3  | 0.27936             |                |        |
|                | 3-DH5  | 0.32171             |                |        |

For GFSK,  $\pi/4$ -DQPSK and 8DPSK:

The test period:  $T = 0.4 \text{ Second/Channel} \times 79 \text{ Channel} = 31.6 \text{ s}$

DH1 time slot =  $0.448 \times (1600 / (2 \times 79)) \times 31.6 = 143.36 \text{ ms}$

DH3 time slot =  $1.728 \times (1600 / (4 \times 79)) \times 31.6 = 276.48 \text{ ms}$

DH5 time slot =  $3.008 \times (1600 / (6 \times 79)) \times 31.6 = 320.85 \text{ ms}$

2-DH1 time slot =  $0.454 \times (1600 / (2 \times 79)) \times 31.6 = 145.28 \text{ ms}$

2-DH3 time slot =  $1.722 \times (1600 / (4 \times 79)) \times 31.6 = 275.52 \text{ ms}$

2-DH5 time slot =  $3.008 \times (1600 / (6 \times 79)) \times 31.6 = 320.85 \text{ ms}$

3-DH1 time slot =  $0.460 \times (1600 / (2 \times 79)) \times 31.6 = 147.20 \text{ ms}$

3-DH3 time slot =  $1.746 \times (1600 / (4 \times 79)) \times 31.6 = 279.36 \text{ ms}$

3-DH5 time slot =  $3.016 \times (1600 / (6 \times 79)) \times 31.6 = 321.71 \text{ ms}$

Test plot as follows:

|                  |      |
|------------------|------|
| Modulation mode: | GFSK |
|------------------|------|

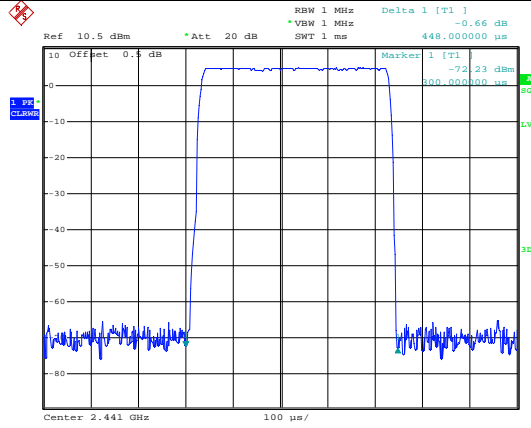

Date: 4.JUL.2013 14:47:15

DH1

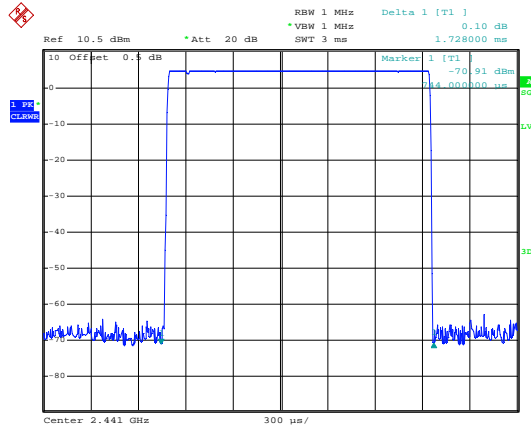

Date: 4.JUL.2013 14:49:33

DH3

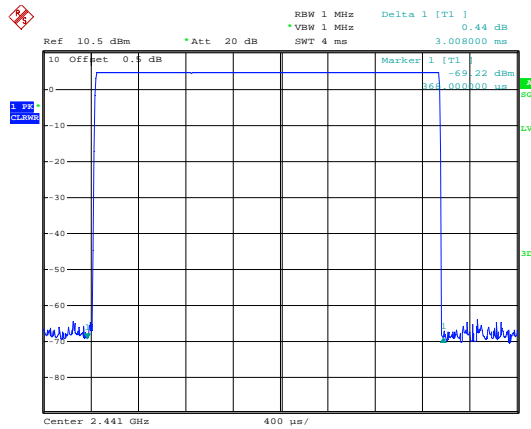

Date: 4.JUL.2013 14:51:28

DH5

Modulation mode: π/4-DQPSK

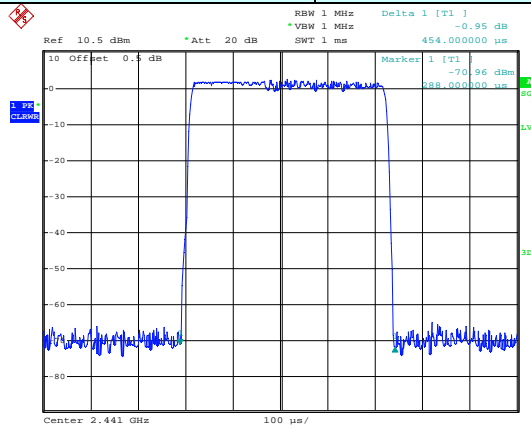

Date: 4.JUL.2013 14:53:16

### 2-DH1

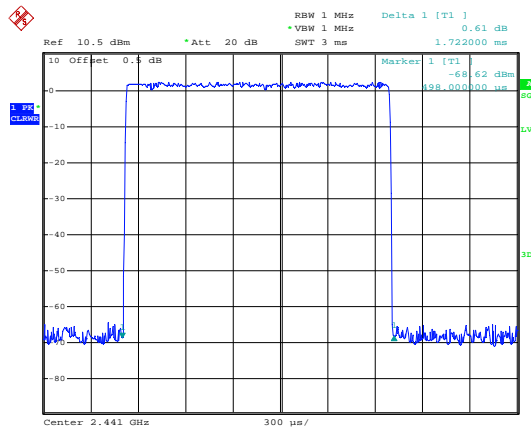

Date: 4.JUL.2013 14:55:45

### 2-DH3

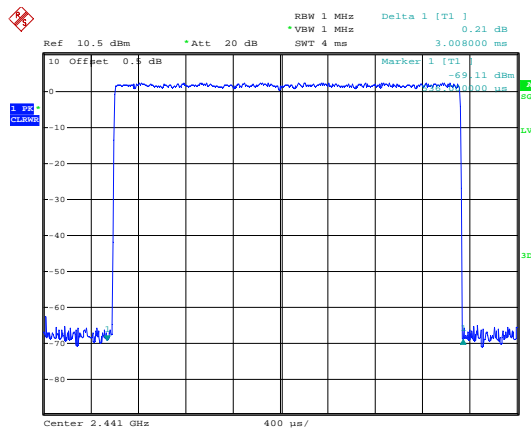

Date: 4.JUL.2013 14:58:04

### 2-DH5

Modulation mode: 8DPSK

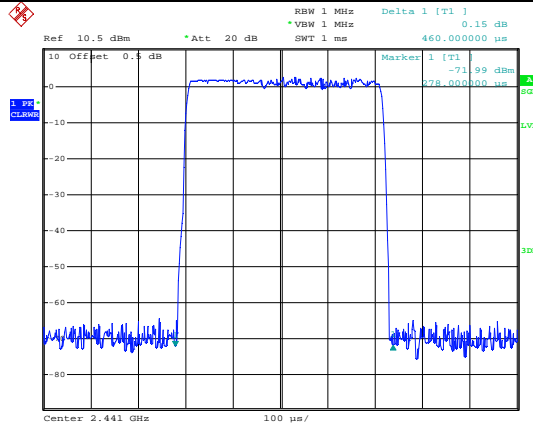

Date: 4.JUL.2013 14:59:38

### 3-DH1

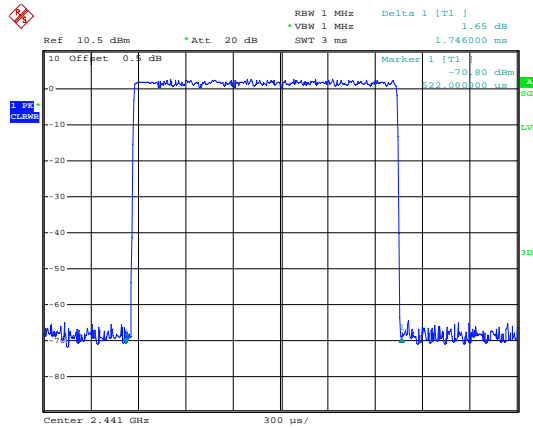

Date: 4.JUL.2013 15:02:00

### 3-DH3

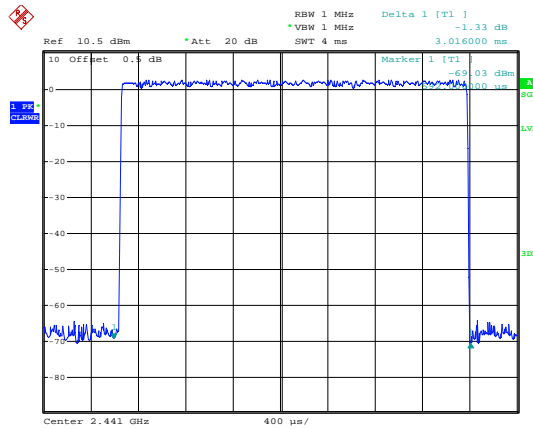

Date: 4.JUL.2013 15:04:34

### 3-DH5

## 6.8 Pseudorandom Frequency Hopping Sequence

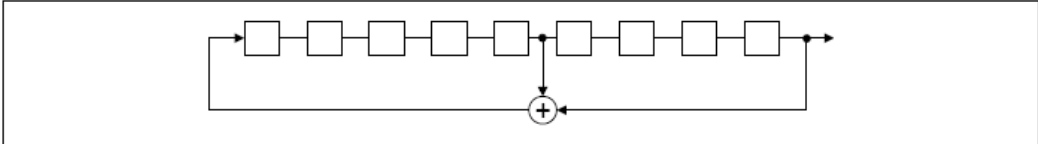
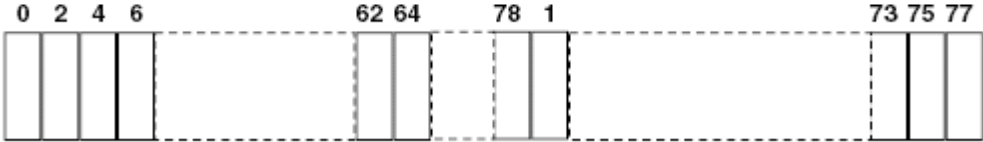
|  |  |
|--|--|
| <b>Test Requirement:</b>   | <b>FCC Part15 C Section 15.247 (a)(1) requirement:</b> |
| <p>Frequency hopping systems shall have hopping channel carrier frequencies separated by a minimum of 25 kHz or the 20 dB bandwidth of the hopping channel, whichever is greater.</p> <p>Alternatively. Frequency hopping systems operating in the 2400-2483.5 MHz band may have hopping channel carrier frequencies that are separated by 25 kHz or two-thirds of the 20 dB bandwidth of the hopping channel, whichever is greater, provided the systems operate with an output power no greater than 125 mW. The system shall hop to channel frequencies that are selected at the system hopping rate from a Pseudorandom ordered list of hopping frequencies. Each frequency must be used equally on the average by each transmitter. The system receivers shall have input bandwidths that match the hopping channel bandwidths of their corresponding transmitters and shall shift frequencies in synchronization with the transmitted signals.</p> |  |
| <b>EUT Pseudorandom Frequency Hopping Sequence</b>   |  |
| <p>The pseudorandom sequence may be generated in a nine-stage shift register whose 5th and 9th stage outputs are added in a modulo-two addition stage. And the result is fed back to the input of the first stage. The sequence begins with the first ONE of 9 consecutive ONES; i.e. the shift register is initialized with nine ones.</p> <ul style="list-style-type: none"> <li>• Number of shift register stages: 9</li> <li>• Length of pseudo-random sequence: <math>2^9 - 1 = 511</math> bits</li> <li>• Longest sequence of zeros: 8 (non-inverted signal)</li> </ul>  |  |
|   |  |
| <p><i>Linear Feedback Shift Register for Generation of the PRBS sequence</i></p>   |  |
| <p>An example of Pseudorandom Frequency Hopping Sequence as follow:</p>  |  |
|    |  |
| <p>Each frequency used equally on the average by each transmitter.</p> <p>The system receivers have input bandwidths that match the hopping channel bandwidths of their corresponding transmitters and shift frequencies in synchronization with the transmitted signals.</p>  |  |



## 6.9 Band Edge

### 6.9.1 Conducted Emission Method

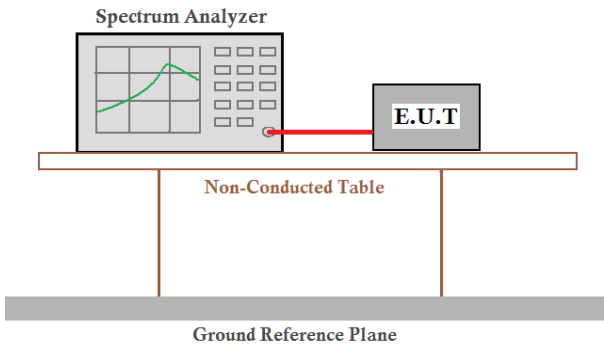
|                   |   |
|-------------------|---|
| Test Requirement: | FCC Part15 C Section 15.247 (d)   |
| Test Method:      | ANSI C63.4:2003 and DA00-705  |
| Receiver setup:   | RBW=100 kHz, VBW=300 kHz, Detector=Peak   |
| Limit:            | In any 100 kHz bandwidth outside the frequency band in which the spread spectrum intentional radiator is operating, the radio frequency power that is produced by the intentional radiator shall be at least 20 dB below that in the 100 kHz bandwidth within the band that contains the highest level of the desired power, based on either an RF conducted or a radiated measurement. |
| Test setup:       |  <p>The diagram illustrates the test setup. A Spectrum Analyzer is connected to an E.U.T. (Equipment Under Test) via a red cable. Both are placed on a Non-Conducted Table, which is supported by a Ground Reference Plane.</p>  |
| Test Instruments: | Refer to section 5.7 for details  |
| Test mode:        | Non-hopping mode and hopping mode   |
| Test results:     | Pass  |

Test plot as follows:

GFSK

|               |                |
|---------------|----------------|
| Test channel: | Lowest channel |
|---------------|----------------|

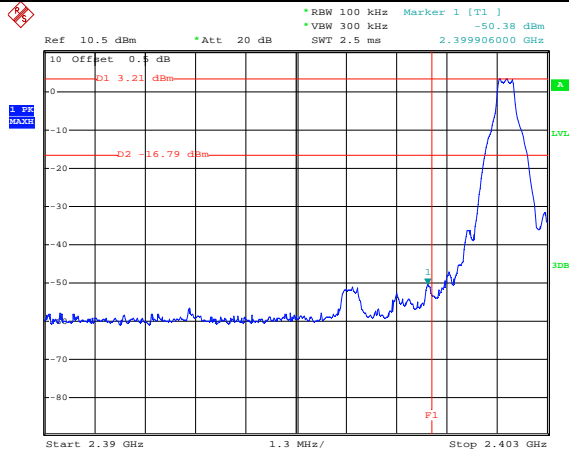

Date: 4.JUL.2013 15:06:58

No-hopping mode

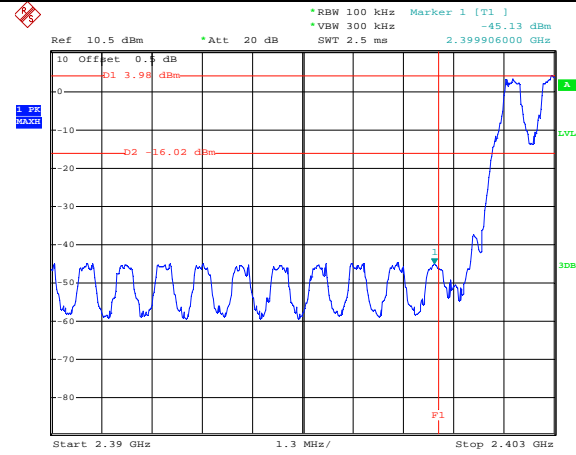

Date: 4.JUL.2013 15:40:05

Hopping mode

|               |                 |
|---------------|-----------------|
| Test channel: | Highest channel |
|---------------|-----------------|

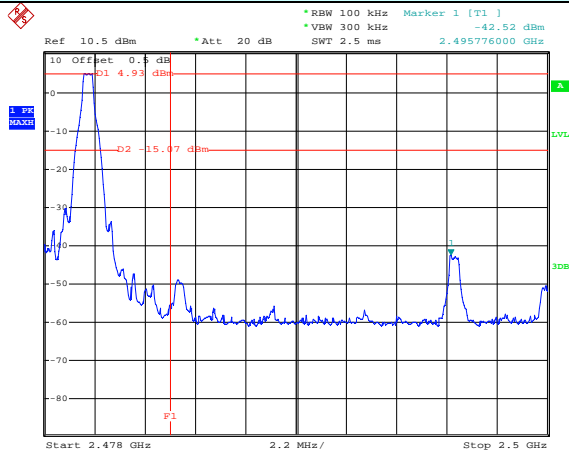

Date: 4.JUL.2013 15:43:56

No-hopping mode

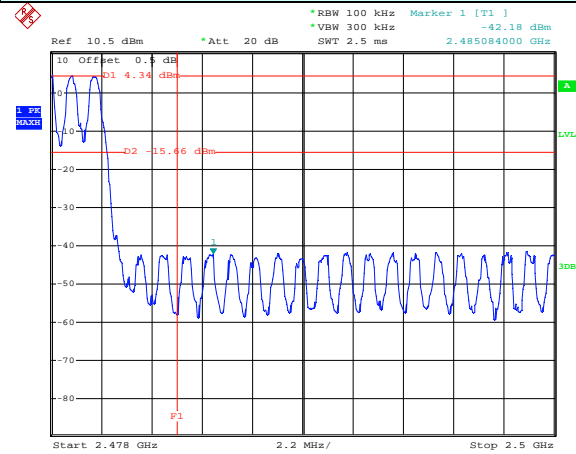

Date: 4.JUL.2013 15:42:36

Hopping mode

$\pi/4$ -DQPSK

Test channel: Lowest channel

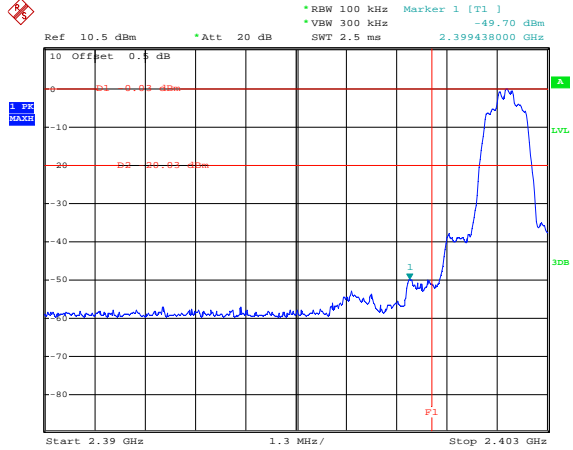

Date: 4.JUL.2013 15:18:34

No-hopping mode

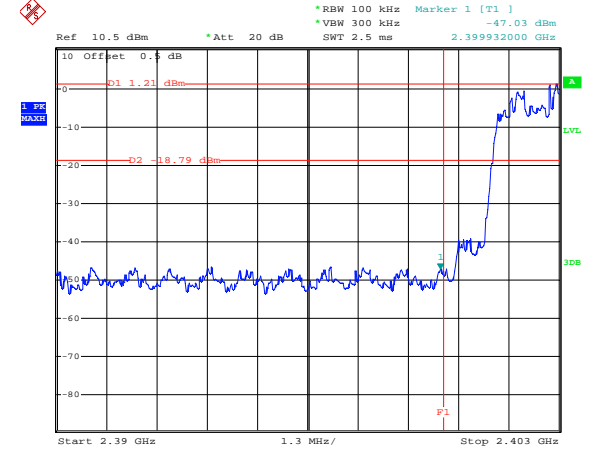

Date: 4.JUL.2013 15:13:46

Hopping mode

Test channel: Highest channel

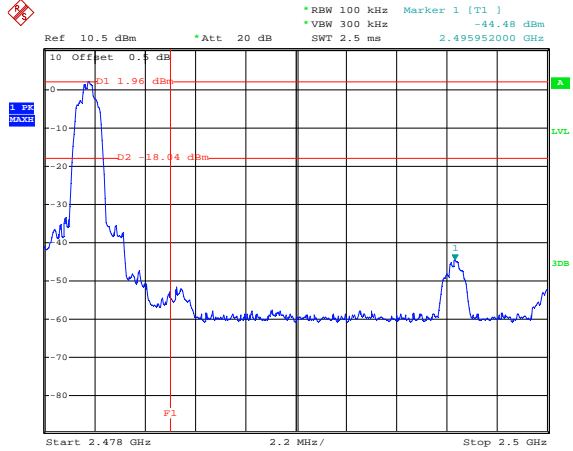

Date: 4.JUL.2013 15:47:18

No-hopping mode

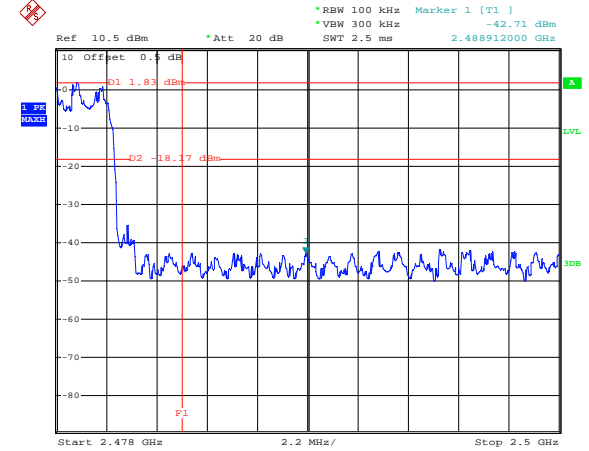

Date: 4.JUL.2013 15:50:25

Hopping mode

8DPSK

Test channel: Lowest channel

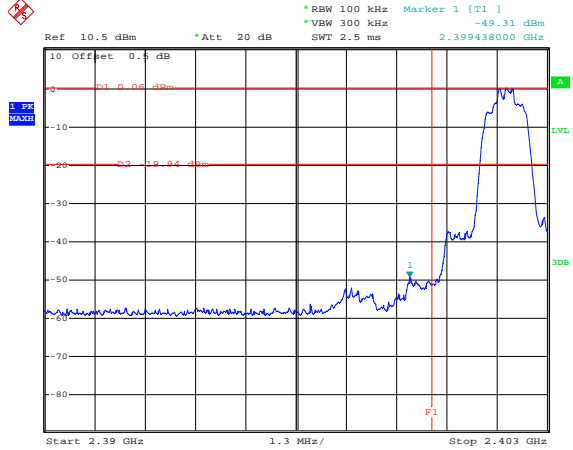

Date: 4.JUL.2013 15:31:45

No-hopping mode

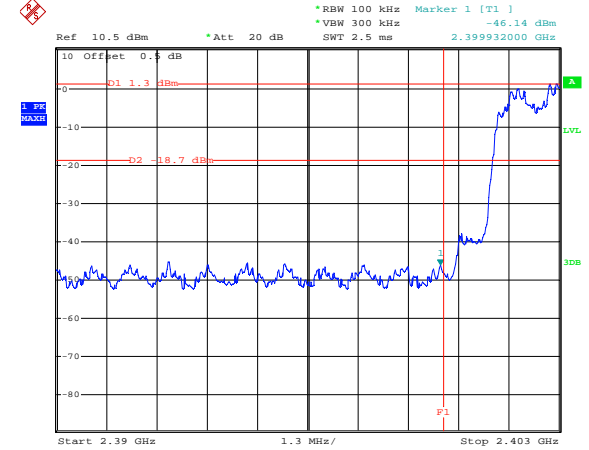

Date: 4.JUL.2013 15:37:08

Hopping mode

Test channel: Highest channel

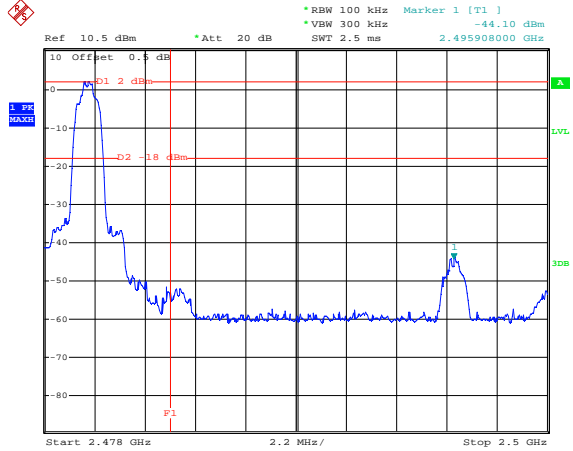

Date: 4.JUL.2013 15:53:59

No-hopping mode

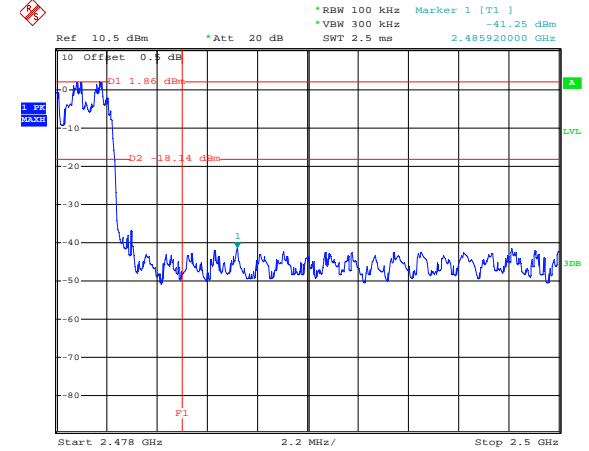

Date: 4.JUL.2013 15:52:38

Hopping mode

## 6.9.2 Radiated Emission Method

|                       |   |          |                    |      |               |
|-----------------------|---|----------|--------------------|------|---------------|
| Test Requirement:     | FCC Part15 C Section 15.209 and 15.205  |          |                    |      |               |
| Test Method:          | ANSI C63.4: 2003  |          |                    |      |               |
| Test Frequency Range: | 2.3GHz to 2.5GHz  |          |                    |      |               |
| Test site:            | Measurement Distance: 3m  |          |                    |      |               |
| Receiver setup:       | Frequency   | Detector | RBW                | VBW  | Remark        |
|                       | Above 1GHz  | Peak     | 1MHz               | 3MHz | Peak Value    |
|                       |   | Peak     | 1MHz               | 10Hz | Average Value |
| Limit:                | Frequency   |          | Limit (dBuV/m @3m) |      | Remark        |
|                       | Above 1GHz  |          | 54.00              |      | Average Value |
|                       |   |          | 74.00              |      | Peak Value    |
| Test setup:           |   |          |                    |      |               |
| Test Procedure:       | <ol style="list-style-type: none"> <li>1. The EUT was placed on the top of a rotating table 0.8 meters above the ground at a 3 meter camber. The table was rotated 360 degrees to determine the position of the highest radiation.</li> <li>2. The EUT was set 3 meters away from the interference-receiving antenna, which was mounted on the top of a variable-height antenna tower.</li> <li>3. The antenna height is varied from one meter to four meters above the ground to determine the maximum value of the field strength. Both horizontal and vertical polarizations of the antenna are set to make the measurement.</li> <li>4. For each suspected emission, the EUT was arranged to its worst case and then the antenna was tuned to heights from 1 meter to 4 meters and the rota table was turned from 0 degrees to 360 degrees to find the maximum reading.</li> <li>5. The test-receiver system was set to Peak Detect Function and Specified Bandwidth with Maximum Hold Mode.</li> <li>6. If the emission level of the EUT in peak mode was 10dB lower than the limit specified, then testing could be stopped and the peak values of the EUT would be reported. Otherwise the emissions that did not have 10dB margin would be re-tested one by one using peak, quasi-peak or average method as specified and then reported in a data sheet.</li> </ol> |          |                    |      |               |
| Test Instruments:     | Refer to section 5.7 for details  |          |                    |      |               |
| Test mode:            | Non-hopping mode  |          |                    |      |               |
| Test results:         | Passed  |          |                    |      |               |

**Remark:**

1. During the test, pre-scan the GFSK,  $\pi/4$ -DQPSK, 8DPSK, and all data were shown in report.
2. Pre-scan all kind of the place mode (X-axis, Y-axis, Z-axis), and found the Y-axis is the worst case.

GFSK mode  
 Test channel: Lowest  
 Horizontal:

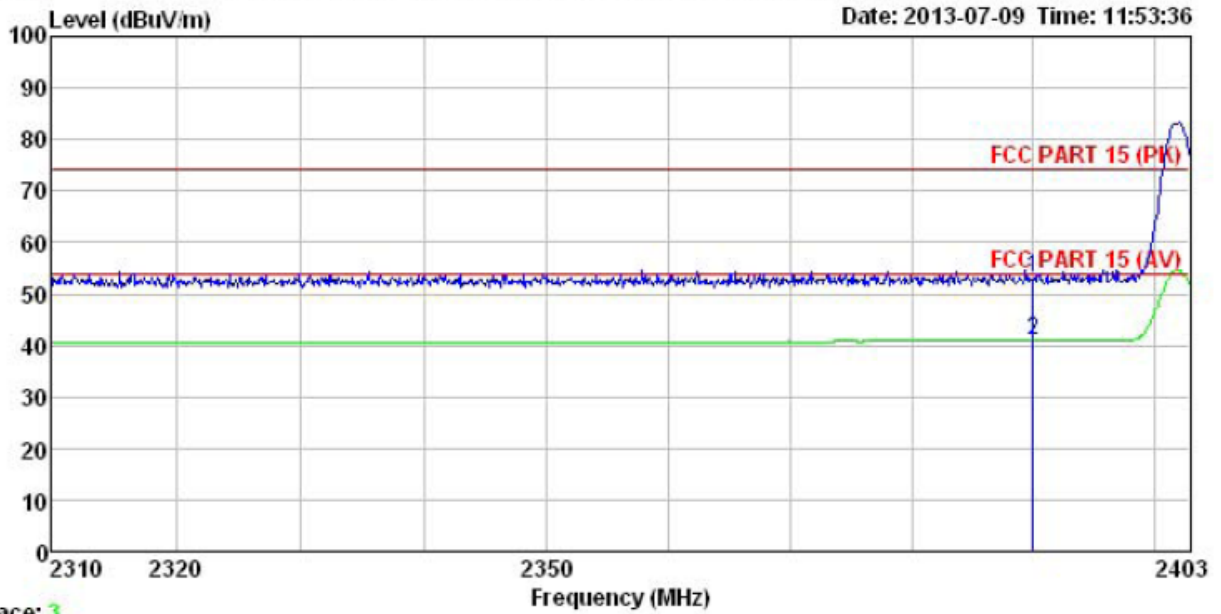

Trace: 3

Site : 3m chamber  
 Condition : FCC PART 15 (PK) 3m BBHA9120(1G18) HORIZONTAL  
 Job No. : 201RF  
 EUT : Stereo Bluetooth Headphone  
 Model : SX-971  
 Test mode : BT (DH1 Low channel) mode  
 Power Rating : AC 120V/60Hz  
 Environment : Temp:25.5°C Humi:55%  
 Test Engineer: Winner  
 Remark :

|   | Freq     | ReadAntenna | Cable  | Preamp | Limit  | Over   |        |                |
|---|----------|-------------|--------|--------|--------|--------|--------|----------------|
|   | MHz      | Level       | Factor | Loss   | Factor | Level  | Line   |                |
|   | MHz      | dBuV        | dB/m   | dB     | dB     | dBuV/m | dBuV/m |                |
| 1 | 2390.000 | 19.75       | 27.58  | 5.67   | 0.00   | 53.00  | 74.00  | -21.00 Peak    |
| 2 | 2390.000 | 7.64        | 27.58  | 5.67   | 0.00   | 40.89  | 54.00  | -13.11 Average |

Vertical:

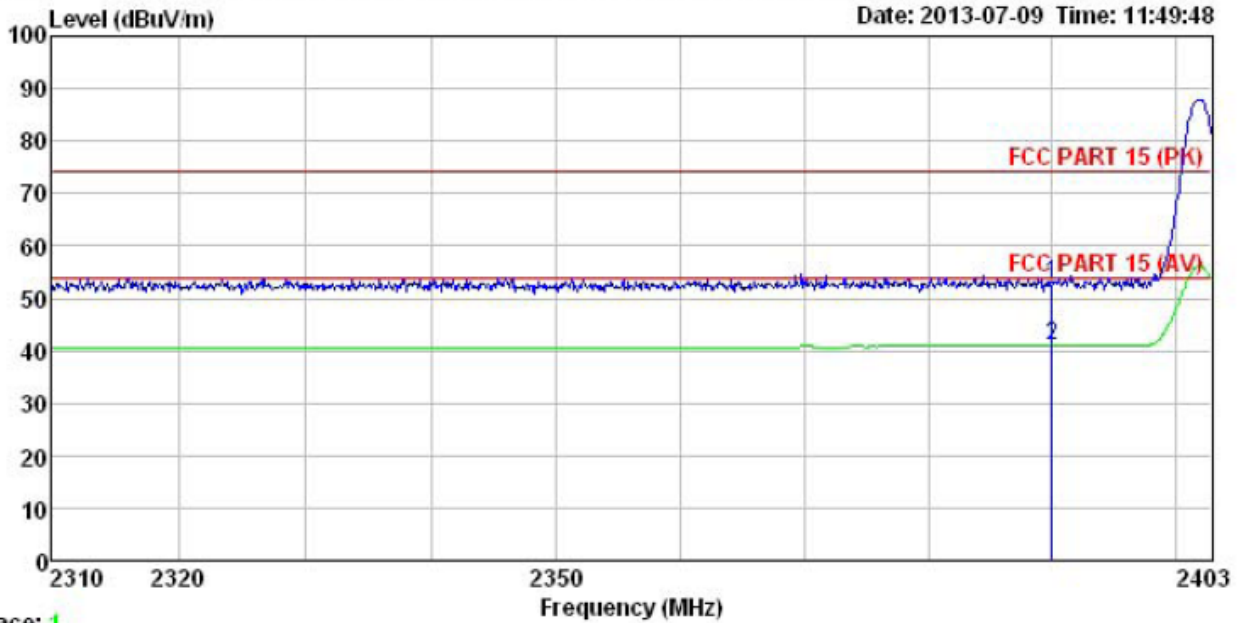

Trace: 1  
 Site : 3m chamber  
 Condition : FCC PART 15 (PK) 3m BBHA9120(1G18) VERTICAL  
 Job No. : 201RF  
 EUT : Stereo Bluetooth Headphone  
 Model : SX-971  
 Test mode : BT (DH1 Low channel) mode  
 Power Rating : AC 120V/60Hz  
 Environment : Temp:25.5°C Humi:55%  
 Test Engineer: Winner  
 Remark :

|   | Freq     | Read Level | Antenna Factor | Cable Loss | Preamp Factor | Level  | Limit Line | Over Limit | Remark  |
|---|----------|------------|----------------|------------|---------------|--------|------------|------------|---------|
|   | MHz      | dBuV       | dB/m           | dB         | dB            | dBuV/m | dBuV/m     | dB         |         |
| 1 | 2390.000 | 19.66      | 27.58          | 5.67       | 0.00          | 52.91  | 74.00      | -21.09     | Peak    |
| 2 | 2390.000 | 7.61       | 27.58          | 5.67       | 0.00          | 40.86  | 54.00      | -13.14     | Average |

Test channel: Highest

Horizontal:

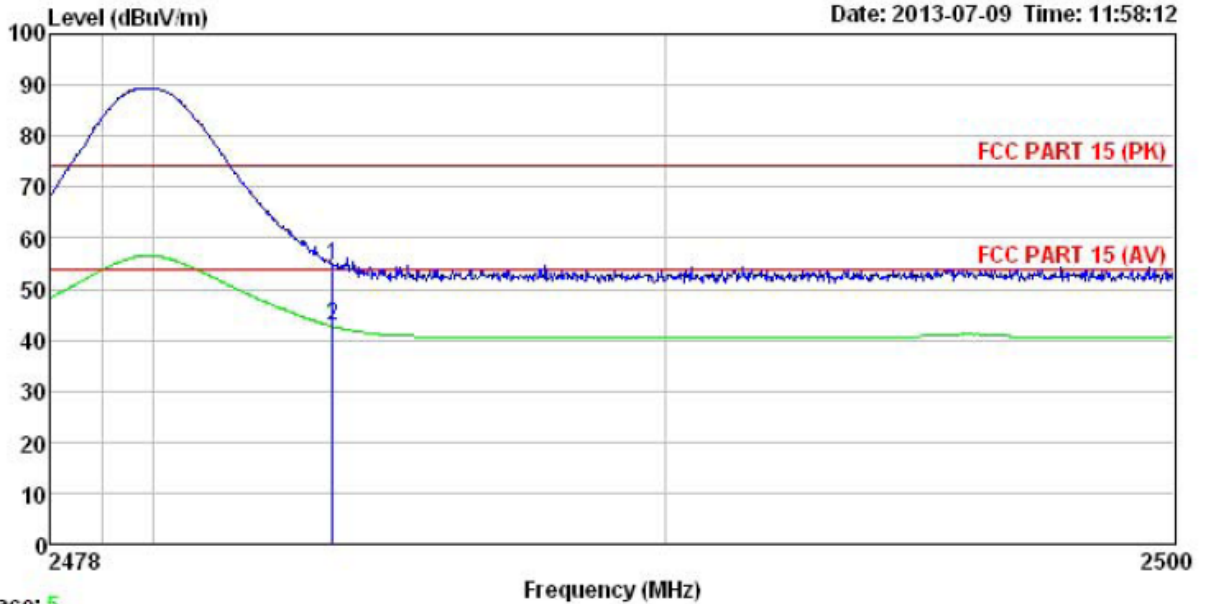

Trace: 5

Site : 3m chamber  
 Condition : FCC PART 15 (PK) 3m BBHA9120(1G18) HORIZONTAL  
 Job No. : 201RF  
 EUT : Stereo Bluetooth Headphone  
 Model : SX-971  
 Test mode : BT (DH1 High channel) mode  
 Power Rating : AC 120V/60Hz  
 Environment : Temp:25.5°C Humi:55%  
 Test Engineer: Winner  
 Remark :

|      | ReadAntenna | Cable  | Preamp | Limit | Over   |        |                      |
|------|-------------|--------|--------|-------|--------|--------|----------------------|
| Freq | Level       | Factor | Loss   | Line  | Limit  | Remark |                      |
| MHz  | dBuV        | dB/m   | dB     | dB    | dBuV/m | dBuV/m | dB                   |
| 1    | 2483.500    | 21.38  | 27.52  | 5.70  | 0.00   | 54.60  | 74.00 -19.40 Peak    |
| 2    | 2483.500    | 9.44   | 27.52  | 5.70  | 0.00   | 42.66  | 54.00 -11.34 Average |



Vertical:

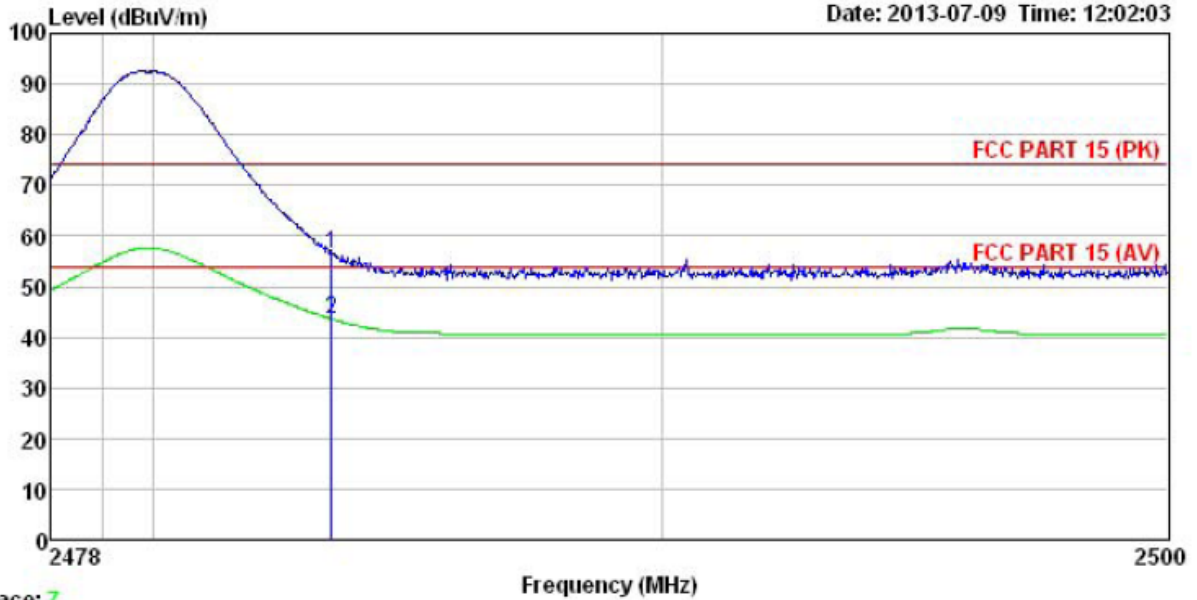

Trace: 7

Site : 3m chamber  
 Condition : FCC PART 15 (PK) 3m BBHA9120(1G18) VERTICAL  
 Job No. : 201RF  
 EUT : Stereo Bluetooth Headphone  
 Model : SX-971  
 Test mode : BT (DH1 High channel) mode  
 Power Rating : AC 120V/60Hz  
 Environment : Temp:25.5°C Humi:55%  
 Test Engineer: Winner  
 Remark :

|   | Freq     | Read Level | Antenna Factor | Cable Loss | Preamp Factor | Level  | Limit  | Over Limit | Remark  |
|---|----------|------------|----------------|------------|---------------|--------|--------|------------|---------|
|   | MHz      | dBuV       | dB/m           | dB         | dB            | dBuV/m | dBuV/m | dB         |         |
| 1 | 2483.500 | 23.41      | 27.52          | 5.70       | 0.00          | 56.63  | 74.00  | -17.37     | Peak    |
| 2 | 2483.500 | 10.37      | 27.52          | 5.70       | 0.00          | 43.59  | 54.00  | -10.41     | Average |

π/4-DQPSK mode  
 Test channel: Lowest  
 Horizontal:

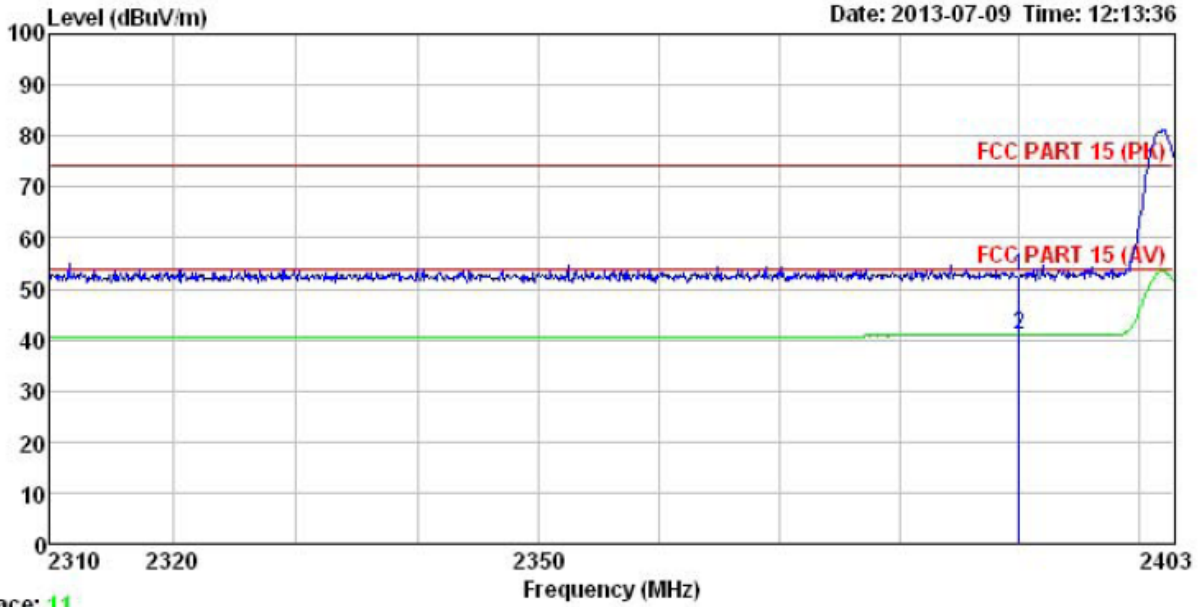

Trace: 11

Site : 3m chamber  
 Condition : FCC PART 15 (PK) 3m BBHA9120(1G18) HORIZONTAL  
 Job No. : 201RF  
 EUT : Stereo Bluetooth Headphone  
 Model : SX-971  
 Test mode : BT (2DH1 Low channel) mode  
 Power Rating : AC 120V/60Hz  
 Environment : Temp:25.5°C Humi:55%  
 Test Engineer: Winner  
 Remark :

|      | ReadAntenna | Cable  | Preamp | Limit  | Over   |              |       |                |
|------|-------------|--------|--------|--------|--------|--------------|-------|----------------|
| Freq | Level       | Factor | Loss   | Factor | Line   | Limit Remark |       |                |
| MHz  | dBuV        | dB/m   | dB     | dB     | dBuV/m | dBuV/m       | dB    |                |
| 1    | 2390.000    | 19.02  | 27.58  | 5.67   | 0.00   | 52.27        | 74.00 | -21.73 Peak    |
| 2    | 2390.000    | 7.62   | 27.58  | 5.67   | 0.00   | 40.87        | 54.00 | -13.13 Average |

Vertical:

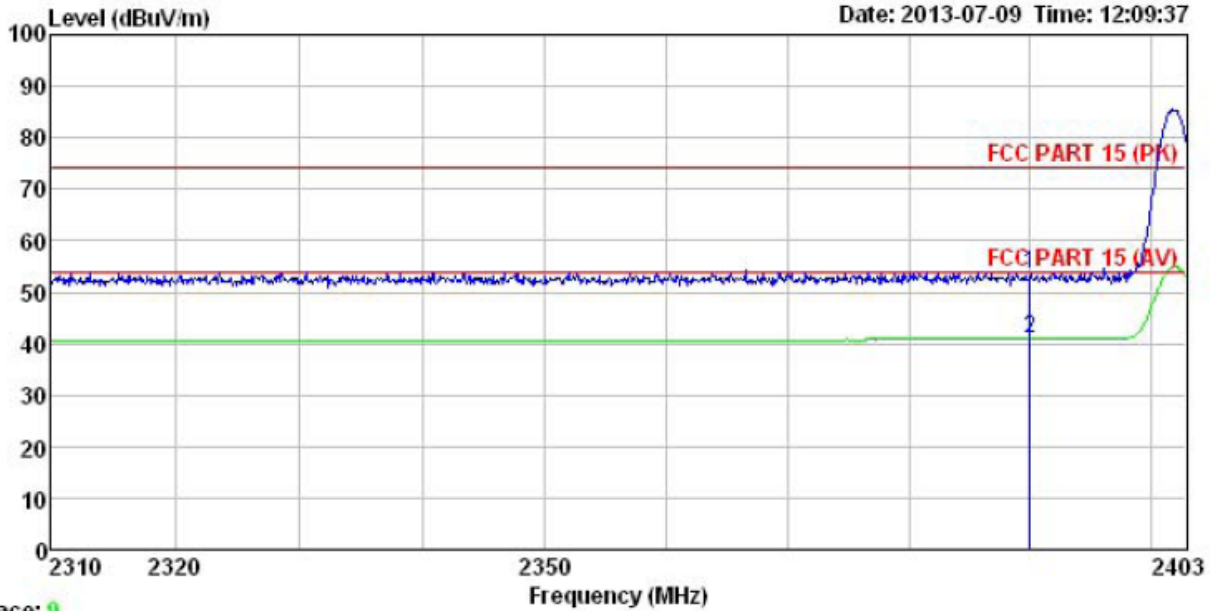

Trace: 9

Site : 3m chamber  
 Condition : FCC PART 15 (PK) 3m BBHA9120(1G18) VERTICAL  
 Job No. : 201RF  
 EUT : Stereo Bluetooth Headphone  
 Model : SX-971  
 Test mode : BT (2DH1 Low channel) mode  
 Power Rating : AC 120V/60Hz  
 Environment : Temp:25.5°C Humi:55%  
 Test Engineer: Winner  
 Remark :

|   | Freq     | Read Level | Antenna Factor | Cable Loss | Preamp Factor | Limit Level | Over Limit | Remark         |
|---|----------|------------|----------------|------------|---------------|-------------|------------|----------------|
|   | MHz      | dBuV       | dB/m           | dB         | dB            | dBuV/m      | dBuV/m     | dB             |
| 1 | 2390.000 | 20.15      | 27.58          | 5.67       | 0.00          | 53.40       | 74.00      | -20.60 Peak    |
| 2 | 2390.000 | 7.63       | 27.58          | 5.67       | 0.00          | 40.88       | 54.00      | -13.12 Average |

Test channel: Highest

Horizontal:

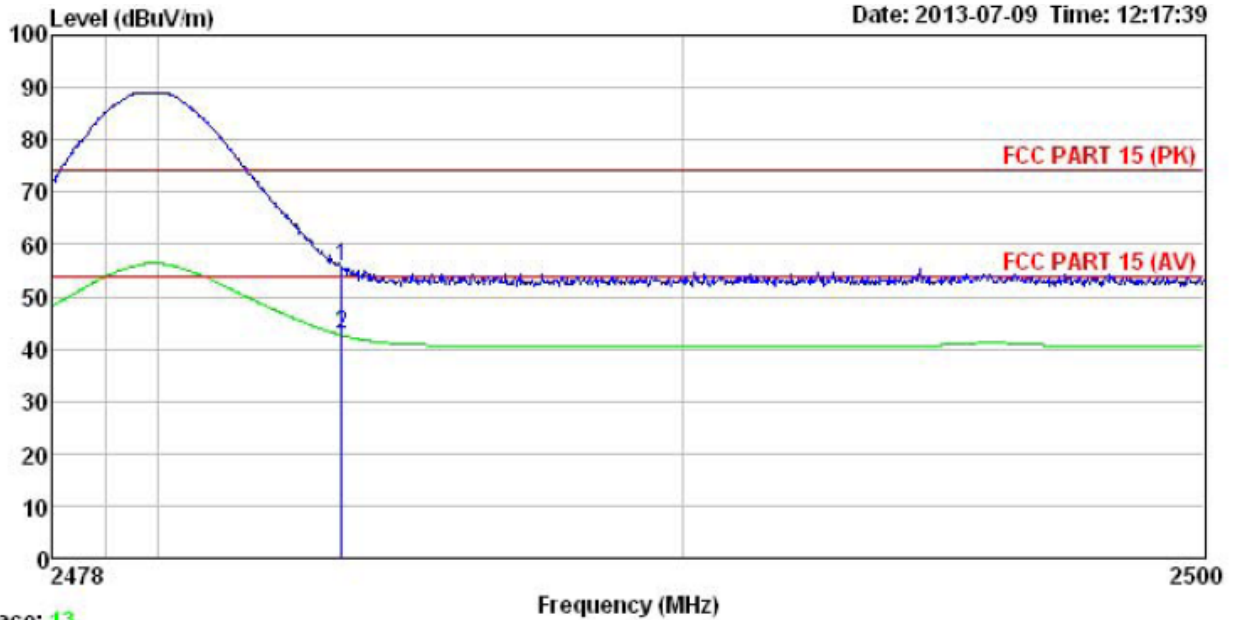

Trace: 13

Site : 3m chamber  
 Condition : FCC PART 15 (PK) 3m BBHA9120(1G18) HORIZONTAL  
 Job No. : 201RF  
 EUT : Stereo Bluetooth Headphone  
 Model : SX-971  
 Test mode : BT (2DH1 High channel) mode  
 Power Rating : AC 120V/60Hz  
 Environment : Temp:25.5°C Humi:55%  
 Test Engineer: Winner  
 Remark :

|      | Read     | Antenna | Cable | Preamp | Limit  | Over   |                      |
|------|----------|---------|-------|--------|--------|--------|----------------------|
| Freq | Level    | Factor  | Loss  | Factor | Line   | Limit  | Remark               |
| MHz  | dBuV     | dB/m    | dB    | dB     | dBuV/m | dBuV/m | dB                   |
| 1    | 2483.500 | 22.41   | 27.52 | 5.70   | 0.00   | 55.63  | 74.00 -18.37 Peak    |
| 2    | 2483.500 | 9.40    | 27.52 | 5.70   | 0.00   | 42.62  | 54.00 -11.38 Average |

Vertical:

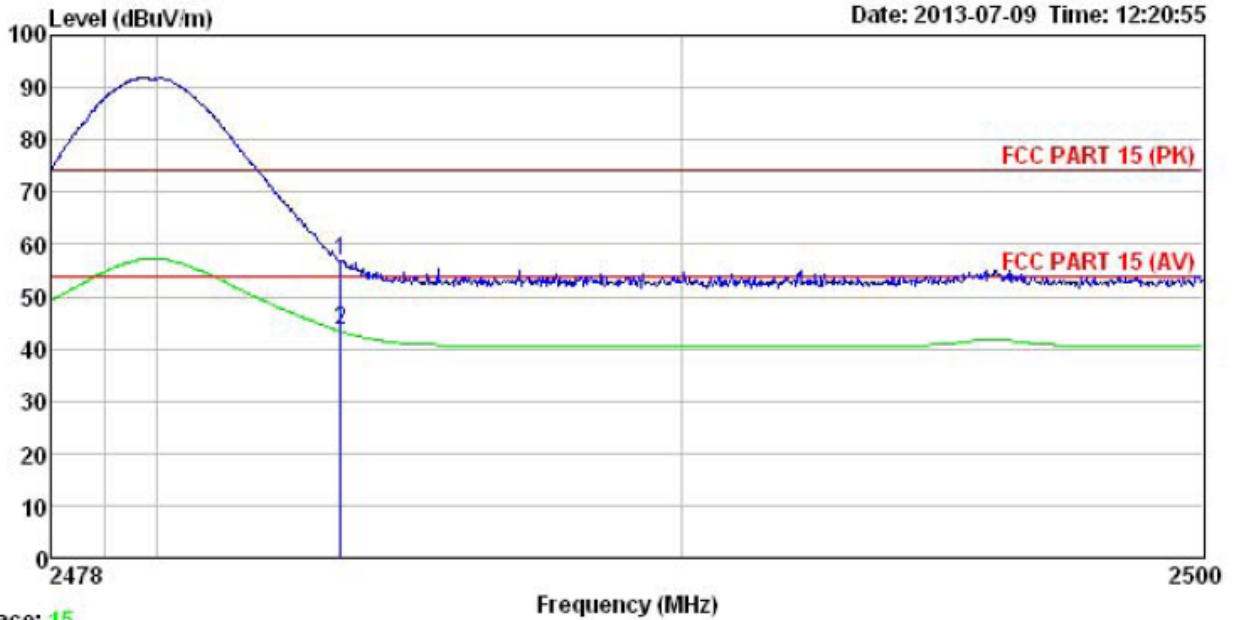

Trace: 15  
 Site : 3m chamber  
 Condition : FCC PART 15 (PK) 3m BBHA9120(1G18) VERTICAL  
 Job No. : 201RF  
 EUT : Stereo Bluetooth Headphone  
 Model : SX-971  
 Test mode : BT (2DH1 High channel) mode  
 Power Rating : AC 120V/60Hz  
 Environment : Temp:25.5°C Humi:55%  
 Test Engineer: Winner  
 Remark :

|   | Freq     | Read Level | Antenna Factor | Cable Loss | Preamp Factor | Level  | Limit Line | Over Limit | Remark  |
|---|----------|------------|----------------|------------|---------------|--------|------------|------------|---------|
|   | MHz      | dBuV       | dB/m           | dB         | dB            | dBuV/m | dBuV/m     | dB         |         |
| 1 | 2483.500 | 23.51      | 27.52          | 5.70       | 0.00          | 56.73  | 74.00      | -17.27     | Peak    |
| 2 | 2483.500 | 10.15      | 27.52          | 5.70       | 0.00          | 43.37  | 54.00      | -10.63     | Average |

8DPSK mode  
 Test channel: Lowest  
 Horizontal:

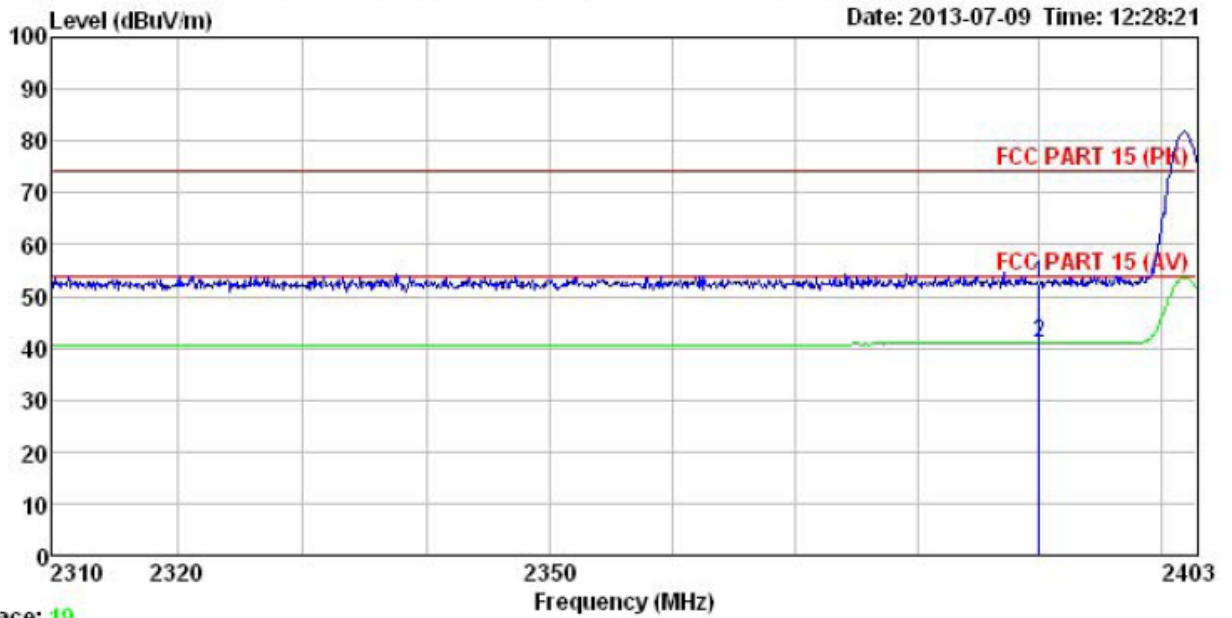

Trace: 19

Site : 3m chamber  
 Condition : FCC PART 15 (PK) 3m BBHA9120(1G18) HORIZONTAL  
 Job No. : 201RF  
 EUT : Stereo Bluetooth Headphone  
 Model : SX-971  
 Test mode : BT (3DH1 Low channel) mode  
 Power Rating : AC 120V/60Hz  
 Environment : Temp:25.5°C Humi:55%  
 Test Engineer: Winner  
 Remark :

|      | Read     | Antenna | Cable | Preamp | Level  | Limit  | Over  |                |
|------|----------|---------|-------|--------|--------|--------|-------|----------------|
| Freq | Level    | Factor  | Loss  | Factor | Level  | Line   | Limit | Remark         |
| MHz  | dBuV     | dB/m    | dB    | dB     | dBuV/m | dBuV/m | dB    |                |
| 1    | 2390.000 | 19.08   | 27.58 | 5.67   | 0.00   | 52.33  | 74.00 | -21.67 Peak    |
| 2    | 2390.000 | 7.67    | 27.58 | 5.67   | 0.00   | 40.92  | 54.00 | -13.08 Average |

Vertical:

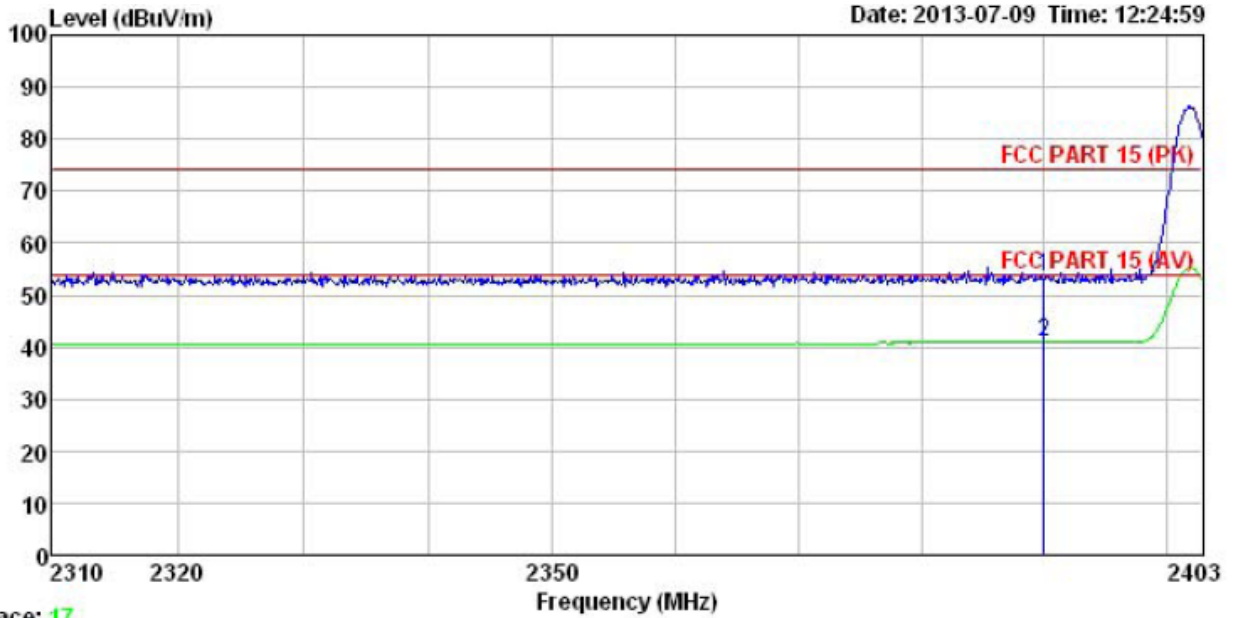

Trace: 17

Site : 3m chamber  
 Condition : FCC PART 15 (PK) 3m BBHA9120(1G18) VERTICAL  
 Job No. : 201RF  
 EUT : Stereo Bluetooth Headphone  
 Model : SX-971  
 Test mode : BT (3DH1 Low channel) mode  
 Power Rating : AC 120V/60Hz  
 Environment : Temp:25.5°C Humi:55%  
 Test Engineer: Winner  
 Remark :

|   | Read Freq | Antenna Level | Antenna Factor | Cable Loss | Preamp Factor | Level  | Limit Line | Over Limit | Remark  |
|---|-----------|---------------|----------------|------------|---------------|--------|------------|------------|---------|
|   | MHz       | dBuV          | dB/m           | dB         | dB            | dBuV/m | dBuV/m     | dB         |         |
| 1 | 2390.000  | 20.11         | 27.58          | 5.67       | 0.00          | 53.36  | 74.00      | -20.64     | Peak    |
| 2 | 2390.000  | 7.62          | 27.58          | 5.67       | 0.00          | 40.87  | 54.00      | -13.13     | Average |

Test channel: Highest

Horizontal:

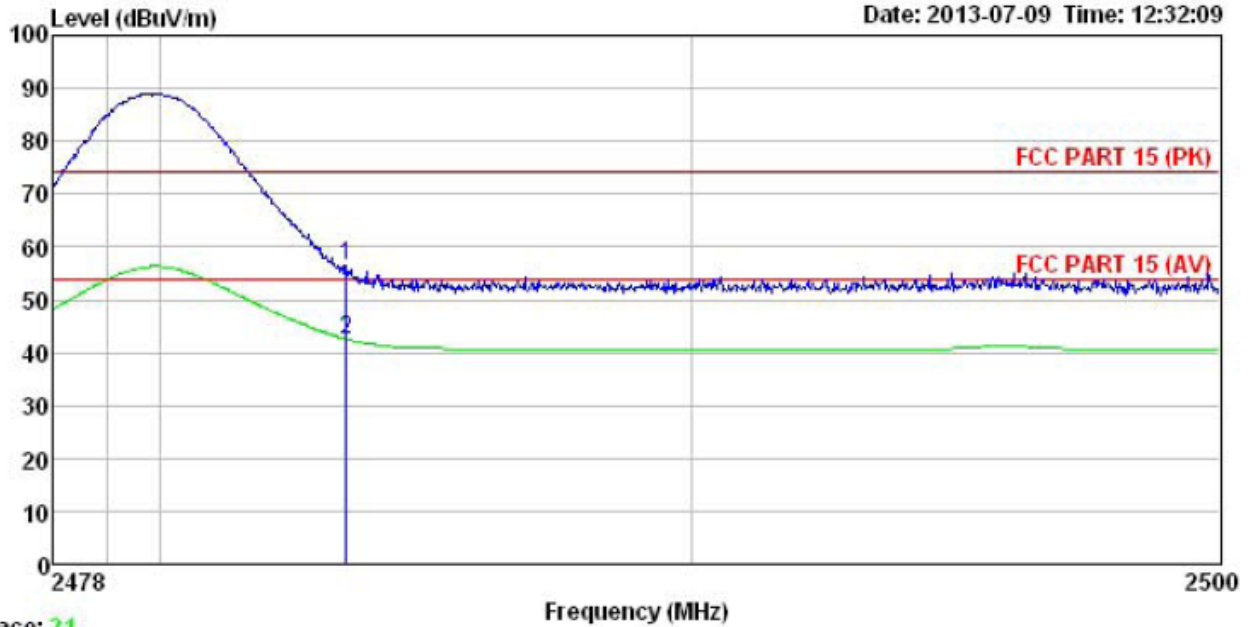

**Trace: 21**

Site : 3m chamber  
 Condition : FCC PART 15 (PK) 3m BBHA9120(1G18) HORIZONTAL  
 Job No. : 201RF  
 EUT : Stereo Bluetooth Headphone  
 Model : SX-971  
 Test mode : BT (3DH1 High channel) mode  
 Power Rating : AC 120V/60Hz  
 Environment : Temp:25.5°C Humi:55%  
 Test Engineer: Winner  
 Remark :

|      | Read     | Antenna | Cable | Preamp | Limit  | Over   |                      |
|------|----------|---------|-------|--------|--------|--------|----------------------|
| Freq | Level    | Factor  | Loss  | Factor | Level  | Line   | Limit Remark         |
| MHz  | dBuV     | dB/m    | dB    | dB     | dBuV/m | dBuV/m | dB                   |
| 1    | 2483.500 | 23.19   | 27.52 | 5.70   | 0.00   | 56.41  | 74.00 -17.59 Peak    |
| 2    | 2483.500 | 9.29    | 27.52 | 5.70   | 0.00   | 42.51  | 54.00 -11.49 Average |



Vertical:

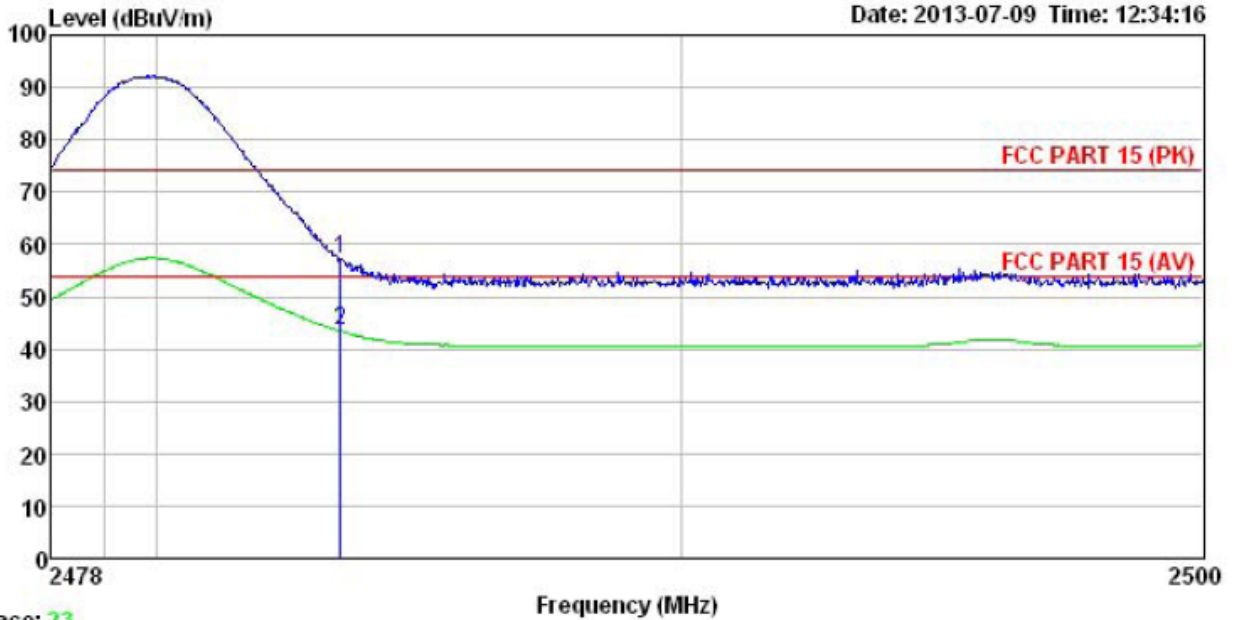

Trace: 23

Site : 3m chamber  
 Condition : FCC PART 15 (PK) 3m BBHA9120(1G18) VERTICAL  
 Job No. : 201RF  
 EUT : Stereo Bluetooth Headphone  
 Model : SX-971  
 Test mode : BT (3DH1 High channel) mode  
 Power Rating : AC 120V/60Hz  
 Environment : Temp:25.5°C Humi:55%  
 Test Engineer: Winner  
 Remark :

|      | Read     | Antenna | Cable | Preamp | Level  | Limit  | Over  |                |
|------|----------|---------|-------|--------|--------|--------|-------|----------------|
| Freq | Level    | Factor  | Loss  | Factor | Level  | Line   | Limit | Remark         |
| MHz  | dBuV     | dB/m    | dB    | dB     | dBuV/m | dBuV/m | dB    |                |
| 1    | 2483.500 | 23.79   | 27.52 | 5.70   | 0.00   | 57.01  | 74.00 | -16.99 Peak    |
| 2    | 2483.500 | 10.21   | 27.52 | 5.70   | 0.00   | 43.43  | 54.00 | -10.57 Average |

## 6.10 Spurious Emission

### 6.10.1 Conducted Emission Method

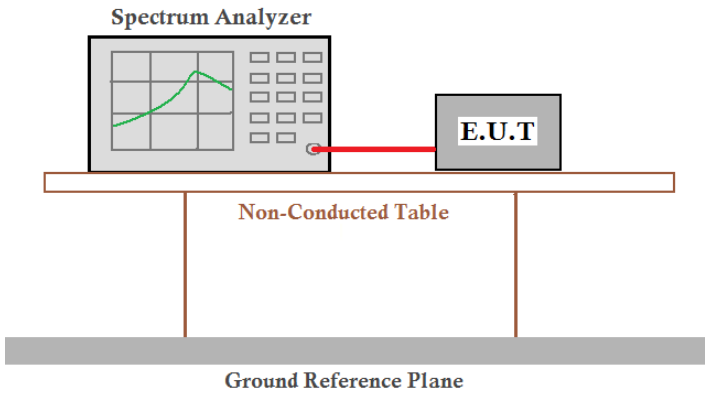
|                   |   |
|-------------------|---|
| Test Requirement: | FCC Part15 C Section 15.247 (d)   |
| Test Method:      | ANSI C63.4:2003 and DA00-705  |
| Limit:            | In any 100 kHz bandwidth outside the frequency band in which the spread spectrum intentional radiator is operating, the radio frequency power that is produced by the intentional radiator shall be at least 20 dB below that in the 100 kHz bandwidth within the band that contains the highest level of the desired power, based on either an RF conducted or a radiated measurement. |
| Test setup:       |  <p>The diagram illustrates the test setup. A Spectrum Analyzer is connected to an E.U.T. (Equipment Under Test) via a red cable. Both are placed on a Non-Conducted Table, which is supported by a Ground Reference Plane.</p>  |
| Test Instruments: | Refer to section 5.7 for details  |
| Test mode:        | Non-hopping mode  |
| Test results:     | Pass  |

GFSK

Lowest channel

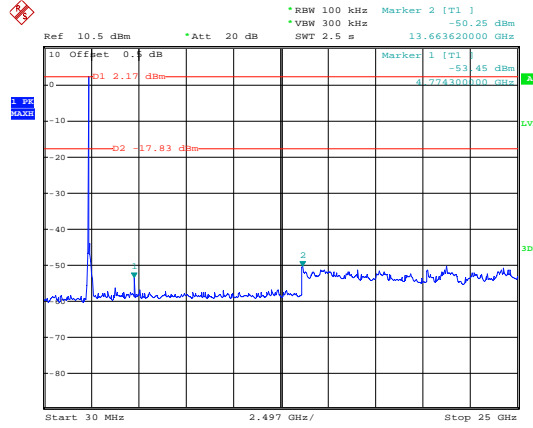

Date: 4.JUL.2013 15:56:26

30MHz~25GHz

Middle channel

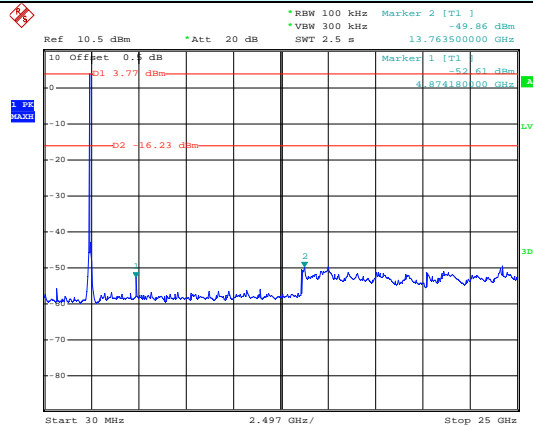

Date: 4.JUL.2013 16:00:00

30MHz~25GHz

Highest channel

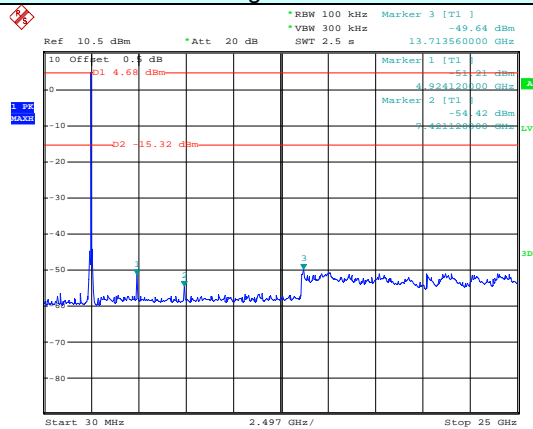

Date: 4.JUL.2013 16:02:29

30MHz~25GHz

$\pi/4$ -DQPSK

Lowest channel

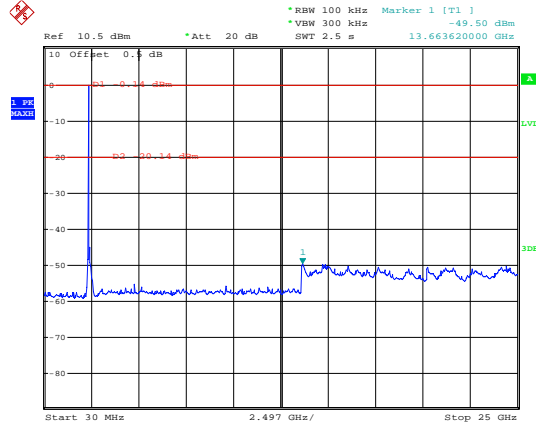

Date: 4.JUL.2013 16:26:29

30MHz~25GHz

Middle channel

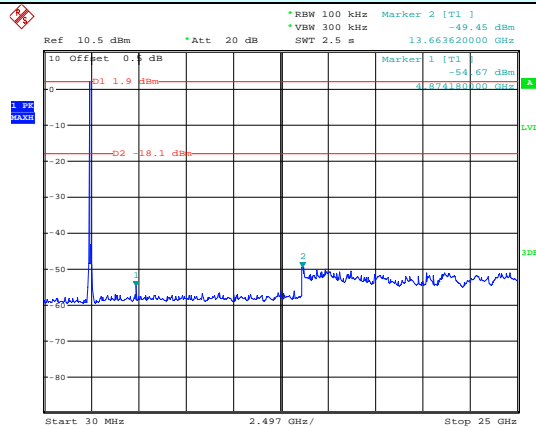

Date: 4.JUL.2013 16:13:48

30MHz~25GHz

Highest channel

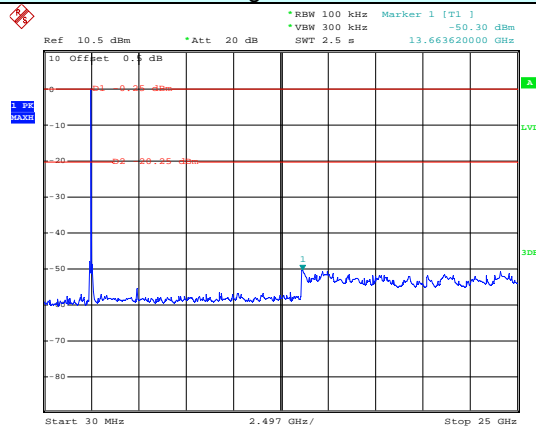

Date: 4.JUL.2013 16:17:15

30MHz~25GHz

8DPSK

Lowest channel

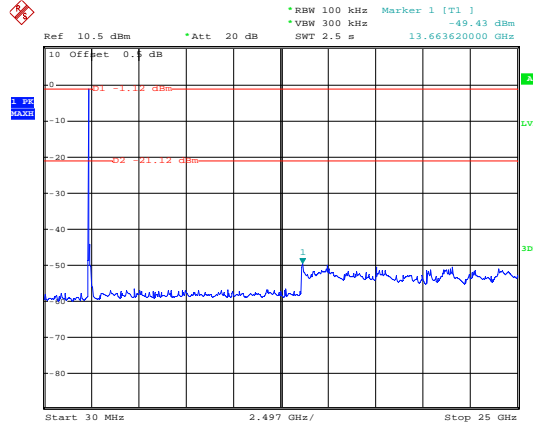

Date: 4.JUL.2013 16:28:37

30MHz~25GHz

Middle channel

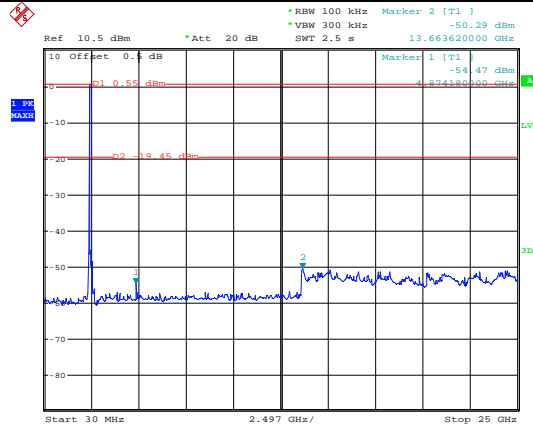

Date: 4.JUL.2013 16:29:48

30MHz~25GHz

Highest channel

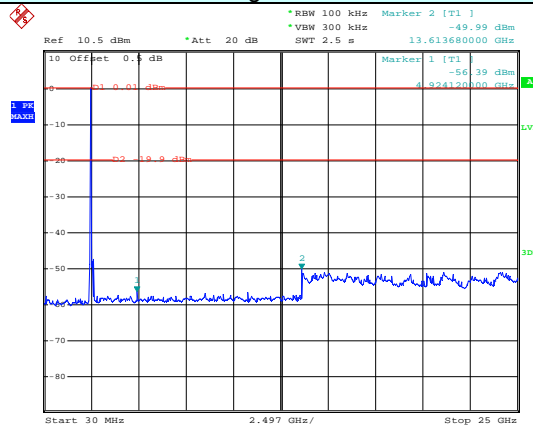

Date: 4.JUL.2013 16:31:08

30MHz~25GHz

## 6.10.2 Radiated Emission Method

|                       |                             |                    |        |                  |                  |
|-----------------------|-----------------------------|--------------------|--------|------------------|------------------|
| Test Requirement:     | FCC Part15 C Section 15.209 |                    |        |                  |                  |
| Test Method:          | ANSI C63.4: 2003            |                    |        |                  |                  |
| Test Frequency Range: | 9 kHz to 25 GHz             |                    |        |                  |                  |
| Test site:            | Measurement Distance: 3m    |                    |        |                  |                  |
| Receiver setup:       | Frequency                   | Detector           | RBW    | VBW              | Remark           |
|                       | 30MHz-1GHz                  | Quasi-peak         | 120kHz | 300kHz           | Quasi-peak Value |
|                       | Above 1GHz                  | Peak               | 1MHz   | 3MHz             | Peak Value       |
| Peak                  |                             | 1MHz               | 10Hz   | Average Value    |                  |
| Limit:                | Frequency                   | Limit (dBuV/m @3m) |        | Remark           |                  |
|                       | 30MHz-88MHz                 | 40.0               |        | Quasi-peak Value |                  |
|                       | 88MHz-216MHz                | 43.5               |        | Quasi-peak Value |                  |
|                       | 216MHz-960MHz               | 46.0               |        | Quasi-peak Value |                  |
|                       | 960MHz-1GHz                 | 54.0               |        | Quasi-peak Value |                  |
|                       | Above 1GHz                  | 54.0               |        | Average Value    |                  |
| 74.0                  |                             | Peak Value         |        |                  |                  |
| Test setup:           | Below 1GHz                  |                    |        |                  |                  |
|                       |                             |                    |        |                  |                  |
| Test setup:           | Above 1GHz                  |                    |        |                  |                  |
|                       |                             |                    |        |                  |                  |

|                   |   |
|-------------------|---|
| Test Procedure:   | <ol style="list-style-type: none"> <li>1. The EUT was placed on the top of a rotating table 0.8 meters above the ground at a 3 meter camber. The table was rotated 360 degrees to determine the position of the highest radiation.</li> <li>2. The EUT was set 3 meters away from the interference-receiving antenna, which was mounted on the top of a variable-height antenna tower.</li> <li>3. The antenna height is varied from one meter to four meters above the ground to determine the maximum value of the field strength. Both horizontal and vertical polarizations of the antenna are set to make the measurement.</li> <li>4. For each suspected emission, the EUT was arranged to its worst case and then the antenna was tuned to heights from 1 meter to 4 meters and the rota table was turned from 0 degrees to 360 degrees to find the maximum reading.</li> <li>5. The test-receiver system was set to Peak Detect Function and Specified Bandwidth with Maximum Hold Mode.</li> <li>6. If the emission level of the EUT in peak mode was 10dB lower than the limit specified, then testing could be stopped and the peak values of the EUT would be reported. Otherwise the emissions that did not have 10dB margin would be re-tested one by one using peak, quasi-peak or average method as specified and then reported in a data sheet.</li> </ol> |
| Test Instruments: | Refer to section 5.7 for details  |
| Test mode:        | Non-hopping mode  |
| Test results:     | Pass  |

**Remark:**

1. During the test, pre-scan the GFSK,  $\pi/4$ -DQPSK, 8DPSK modulation, and found the GFSK modulation is the worst case.
2. Pre-scan all kind of the place mode (X-axis, Y-axis, Z-axis), and found the Y-axis is the worst case.
3. 9 kHz to 30 MHz is noise floor, so only shows the data of above 30MHz in this report.

**Measurement data:**

**Below 1GHz**

Vertical:

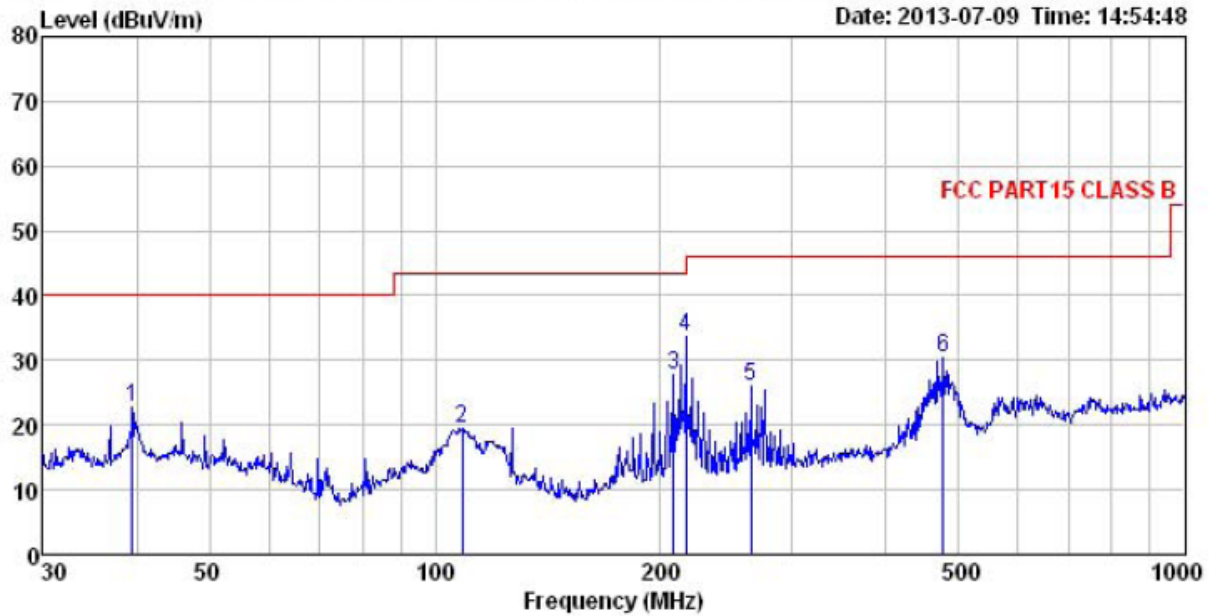

Site : 3m chamber  
 Condition : FCC PART15 CLASS B 3m VULB9163(30M1G) VERTICAL  
 Job No. : 201RF  
 EUT : Stereo Bluetooth Headphone  
 Model : SX-971  
 Test mode : BT TX mode  
 Power Rating : AC 120V/60Hz  
 Environment : Temp:25.5°C Humi:55%  
 Test Engineer: Winner  
 Remark :

|      | Read    | Antenna | Cable | Preamp | Level  | Limit  | Over  |           |
|------|---------|---------|-------|--------|--------|--------|-------|-----------|
| Freq | Level   | Factor  | Loss  | Factor | Level  | Line   | Limit | Remark    |
| MHz  | dBuV    | dB/m    | dB    | dB     | dBuV/m | dBuV/m | dB    |           |
| 1    | 39.437  | 35.20   | 13.44 | 1.21   | 27.21  | 22.64  | 40.00 | -17.36 QP |
| 2    | 108.647 | 35.07   | 12.39 | 2.03   | 29.91  | 19.58  | 43.50 | -23.92 QP |
| 3    | 207.850 | 43.92   | 10.80 | 2.86   | 29.78  | 27.80  | 43.50 | -15.70 QP |
| 4    | 216.024 | 49.58   | 11.07 | 2.85   | 29.74  | 33.76  | 46.00 | -12.24 QP |
| 5    | 263.819 | 40.62   | 12.17 | 2.85   | 29.55  | 26.09  | 46.00 | -19.91 QP |
| 6    | 477.169 | 41.37   | 16.01 | 3.42   | 30.52  | 30.28  | 46.00 | -15.72 QP |



Horizontal:

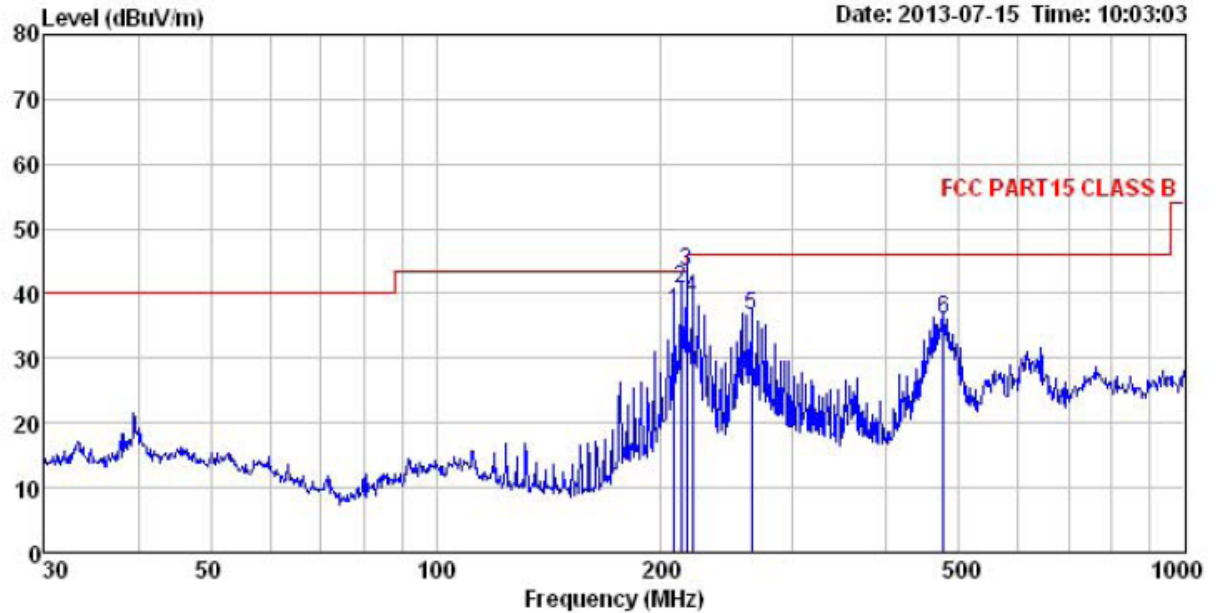

Site : 3m chamber  
 Condition : FCC PART15 CLASS B 3m VULB9163(30M1G) HORIZONTAL  
 Job No. : 201RF  
 EUT : Stereo Bluetooth Headphone  
 Model : SX-971  
 Test mode : BT TX mode  
 Power Rating : AC 120V/60Hz  
 Environment : Temp:25.5°C Humi:55%  
 Test Engineer: Winner  
 Remark :

|      | ReadAntenna | Cable  | Preamp |        | Limit  | Over   |       |          |
|------|-------------|--------|--------|--------|--------|--------|-------|----------|
| Freq | Level       | Factor | Loss   | Factor | Level  | Line   | Limit | Remark   |
| MHz  | dBuV        | dB/m   | dB     | dB     | dBuV/m | dBuV/m | dB    |          |
| 1    | 207.850     | 53.18  | 10.80  | 2.86   | 29.78  | 37.06  | 43.50 | -6.44 QP |
| 2    | 212.270     | 56.81  | 10.93  | 2.86   | 29.75  | 40.85  | 43.50 | -2.65 QP |
| 3    | 216.024     | 59.27  | 11.07  | 2.85   | 29.74  | 43.45  | 46.00 | -2.55 QP |
| 4    | 219.845     | 54.95  | 11.17  | 2.85   | 29.72  | 39.25  | 46.00 | -6.75 QP |
| 5    | 263.819     | 51.08  | 12.17  | 2.85   | 29.55  | 36.55  | 46.00 | -9.45 QP |
| 6    | 477.169     | 47.10  | 16.01  | 3.42   | 30.52  | 36.01  | 46.00 | -9.99 QP |

**Above 1GHz:**

|               |        |        |      |
|---------------|--------|--------|------|
| Test channel: | Lowest | Level: | Peak |
|---------------|--------|--------|------|

| Frequency (MHz) | Read Level (dBuV) | Antenna Factor (dB/m) | Cable Loss (dB) | Preamp Factor (dB) | Level (dBuV/m) | Limit Line (dBuV/m) | Over Limit (dB) | Polarization |
|-----------------|-------------------|-----------------------|-----------------|--------------------|----------------|---------------------|-----------------|--------------|
| 4804.00         | 54.12             | 31.53                 | 8.90            | 40.24              | 54.31          | 74.00               | -19.69          | Vertical     |
| 7206.00         | 49.56             | 36.47                 | 10.59           | 41.24              | 55.38          | 74.00               | -18.62          | Vertical     |
| 9608.00         | 46.85             | 38.10                 | 13.16           | 41.40              | 56.71          | 74.00               | -17.29          | Vertical     |
| 4804.00         | 54.65             | 31.53                 | 8.90            | 40.24              | 54.84          | 74.00               | -19.16          | Horizontal   |
| 7206.00         | 49.54             | 36.47                 | 10.59           | 41.24              | 55.36          | 74.00               | -18.64          | Horizontal   |
| 9608.00         | 46.87             | 38.10                 | 13.16           | 41.40              | 56.73          | 74.00               | -17.27          | Horizontal   |

|               |        |        |         |
|---------------|--------|--------|---------|
| Test channel: | Lowest | Level: | Average |
|---------------|--------|--------|---------|

| Frequency (MHz) | Read Level (dBuV) | Antenna Factor (dB/m) | Cable Loss (dB) | Preamp Factor (dB) | Level (dBuV/m) | Limit Line (dBuV/m) | Over Limit (dB) | Polarization |
|-----------------|-------------------|-----------------------|-----------------|--------------------|----------------|---------------------|-----------------|--------------|
| 4804.00         | 35.45             | 31.53                 | 8.90            | 40.24              | 35.64          | 54.00               | -18.36          | Vertical     |
| 7206.00         | 30.86             | 36.47                 | 10.59           | 41.24              | 36.68          | 54.00               | -17.32          | Vertical     |
| 9608.00         | 27.42             | 38.10                 | 13.16           | 41.40              | 37.28          | 54.00               | -16.72          | Vertical     |
| 4804.00         | 35.12             | 31.53                 | 8.90            | 40.24              | 35.31          | 54.00               | -18.69          | Horizontal   |
| 7206.00         | 30.89             | 36.47                 | 10.59           | 41.24              | 36.71          | 54.00               | -17.29          | Horizontal   |
| 9608.00         | 27.46             | 38.10                 | 13.16           | 41.40              | 37.32          | 54.00               | -16.68          | Horizontal   |

*Remark:*

1. *Final Level = Receiver Read level + Antenna Factor + Cable Loss – Pre-amplifier Factor*
2. *The emission levels of other frequencies are very lower than the limit and not show in test report.*

|               |        |        |      |
|---------------|--------|--------|------|
| Test channel: | Middle | Level: | Peak |
|---------------|--------|--------|------|

| Frequency (MHz) | Read Level (dBuV) | Antenna Factor (dB/m) | Cable Loss (dB) | Preamp Factor (dB) | Level (dBuV/m) | Limit Line (dBuV/m) | Over Limit (dB) | Polarization |
|-----------------|-------------------|-----------------------|-----------------|--------------------|----------------|---------------------|-----------------|--------------|
| 4882.00         | 54.36             | 31.58                 | 8.98            | 40.15              | 54.77          | 74.00               | -19.23          | Vertical     |
| 7323.00         | 49.66             | 36.47                 | 10.69           | 41.15              | 55.67          | 74.00               | -18.33          | Vertical     |
| 9764.00         | 46.54             | 38.45                 | 13.37           | 41.71              | 56.65          | 74.00               | -17.35          | Vertical     |
| 4882.00         | 53.95             | 31.58                 | 8.98            | 40.15              | 54.36          | 74.00               | -19.64          | Horizontal   |
| 7323.00         | 49.74             | 36.47                 | 10.69           | 41.15              | 55.75          | 74.00               | -18.25          | Horizontal   |
| 9764.00         | 46.65             | 38.45                 | 13.37           | 41.71              | 56.76          | 74.00               | -17.24          | Horizontal   |

|               |        |        |         |
|---------------|--------|--------|---------|
| Test channel: | Middle | Level: | Average |
|---------------|--------|--------|---------|

| Frequency (MHz) | Read Level (dBuV) | Antenna Factor (dB/m) | Cable Loss (dB) | Preamp Factor (dB) | Level (dBuV/m) | Limit Line (dBuV/m) | Over Limit (dB) | Polarization |
|-----------------|-------------------|-----------------------|-----------------|--------------------|----------------|---------------------|-----------------|--------------|
| 4882.00         | 35.01             | 31.58                 | 8.98            | 40.15              | 35.42          | 54.00               | -18.58          | Vertical     |
| 7323.00         | 30.21             | 36.47                 | 10.69           | 41.15              | 36.22          | 54.00               | -17.78          | Vertical     |
| 9764.00         | 27.51             | 38.45                 | 13.37           | 41.71              | 37.62          | 54.00               | -16.38          | Vertical     |
| 4882.00         | 35.12             | 31.58                 | 8.98            | 40.15              | 35.53          | 54.00               | -18.47          | Horizontal   |
| 7323.00         | 30.24             | 36.47                 | 10.69           | 41.15              | 36.25          | 54.00               | -17.75          | Horizontal   |
| 9764.00         | 27.33             | 38.45                 | 13.37           | 41.71              | 37.44          | 54.00               | -16.56          | Horizontal   |

Remark:

1. Final Level = Receiver Read level + Antenna Factor + Cable Loss – Pre-amplifier Factor
2. The emission levels of other frequencies are very lower than the limit and not show in test report.

|               |         |        |      |
|---------------|---------|--------|------|
| Test channel: | Highest | Level: | Peak |
|---------------|---------|--------|------|

| Frequency (MHz) | Read Level (dBuV) | Antenna Factor (dB/m) | Cable Loss (dB) | Preamp Factor (dB) | Level (dBuV/m) | Limit Line (dBuV/m) | Over Limit (dB) | Polarization |
|-----------------|-------------------|-----------------------|-----------------|--------------------|----------------|---------------------|-----------------|--------------|
| 4960.00         | 53.65             | 31.69                 | 9.08            | 40.03              | 54.39          | 74.00               | -19.61          | Vertical     |
| 7440.00         | 49.54             | 36.60                 | 10.80           | 41.05              | 55.89          | 74.00               | -18.11          | Vertical     |
| 9920.00         | 46.22             | 38.66                 | 13.55           | 41.99              | 56.44          | 74.00               | -17.56          | Vertical     |
| 4960.00         | 54.05             | 31.69                 | 9.08            | 40.03              | 54.79          | 74.00               | -19.21          | Horizontal   |
| 7440.00         | 49.35             | 36.60                 | 10.80           | 41.05              | 55.70          | 74.00               | -18.30          | Horizontal   |
| 9920.00         | 46.51             | 38.66                 | 13.55           | 41.99              | 56.73          | 74.00               | -17.27          | Horizontal   |

|               |         |        |         |
|---------------|---------|--------|---------|
| Test channel: | Highest | Level: | Average |
|---------------|---------|--------|---------|

| Frequency (MHz) | Read Level (dBuV) | Antenna Factor (dB/m) | Cable Loss (dB) | Preamp Factor (dB) | Level (dBuV/m) | Limit Line (dBuV/m) | Over Limit (dB) | Polarization |
|-----------------|-------------------|-----------------------|-----------------|--------------------|----------------|---------------------|-----------------|--------------|
| 4960.00         | 34.58             | 31.69                 | 9.08            | 40.03              | 35.32          | 54.00               | -18.68          | Vertical     |
| 7440.00         | 30.12             | 36.60                 | 10.80           | 41.05              | 36.47          | 54.00               | -17.53          | Vertical     |
| 9920.00         | 27.42             | 38.66                 | 13.55           | 41.99              | 37.64          | 54.00               | -16.36          | Vertical     |
| 4960.00         | 34.85             | 31.69                 | 9.08            | 40.03              | 35.59          | 54.00               | -18.41          | Horizontal   |
| 7440.00         | 30.18             | 36.60                 | 10.80           | 41.05              | 36.53          | 54.00               | -17.47          | Horizontal   |
| 9920.00         | 27.51             | 38.66                 | 13.55           | 41.99              | 37.73          | 54.00               | -16.27          | Horizontal   |

Remark:

1. Final Level = Receiver Read level + Antenna Factor + Cable Loss – Pre-amplifier Factor
2. The emission levels of other frequencies are very lower than the limit and not show in test report.

## 7 Test Setup Photo

Radiated Spurious Emission

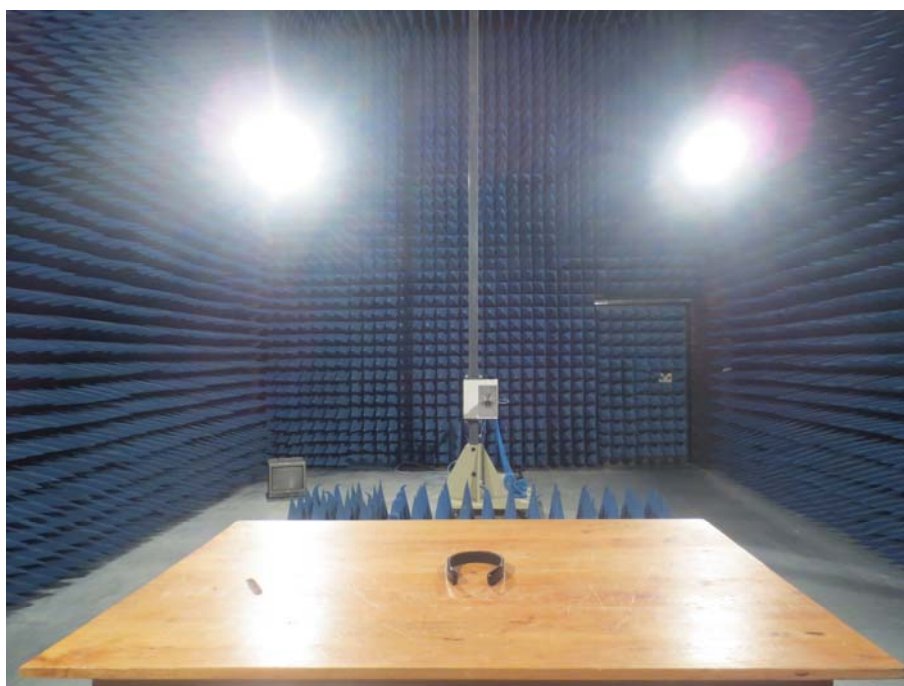
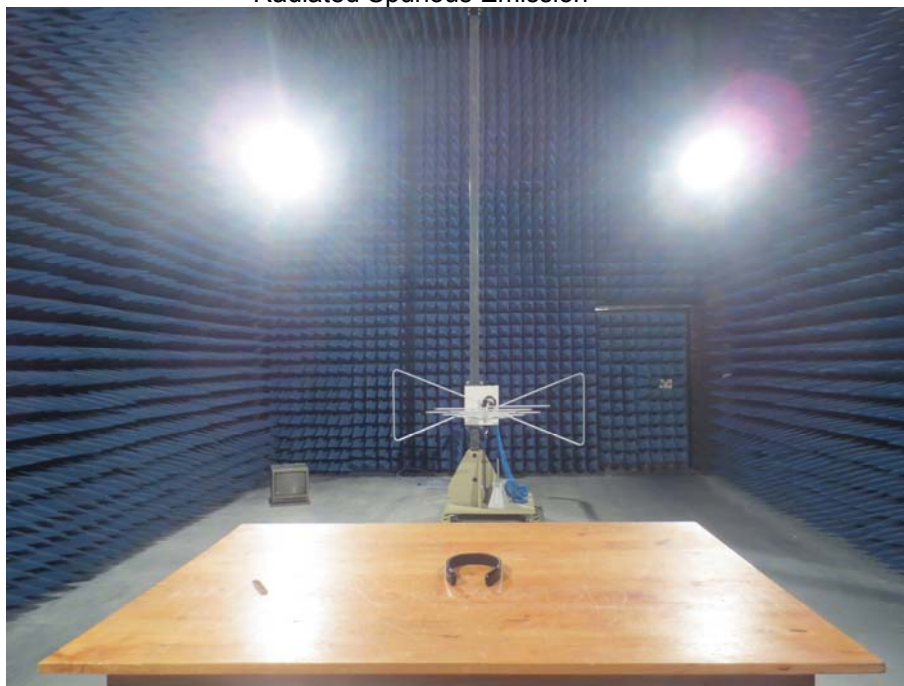

Conducted Emission



## 8 EUT Constructional Details











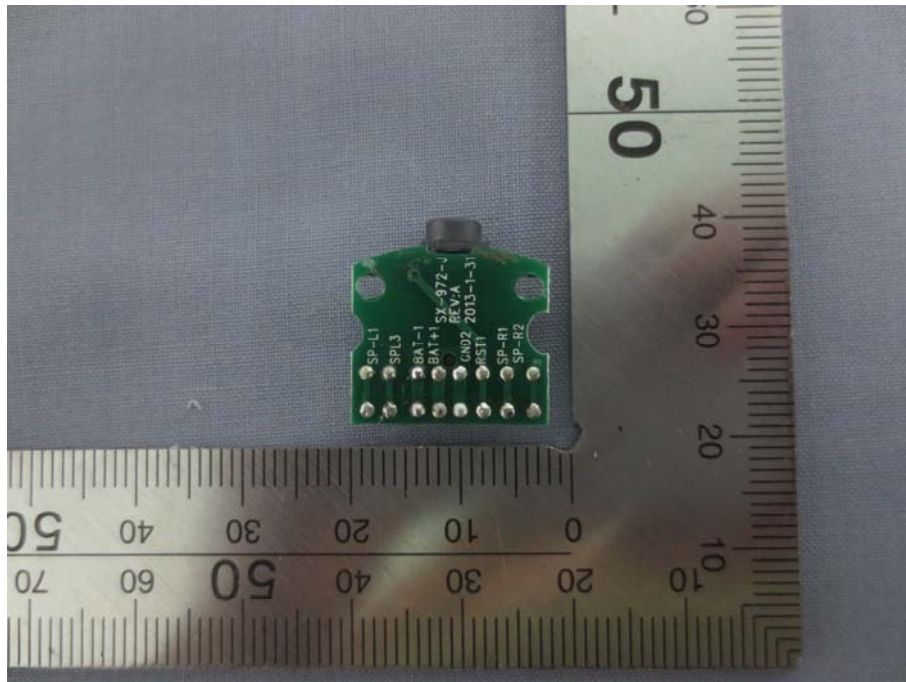
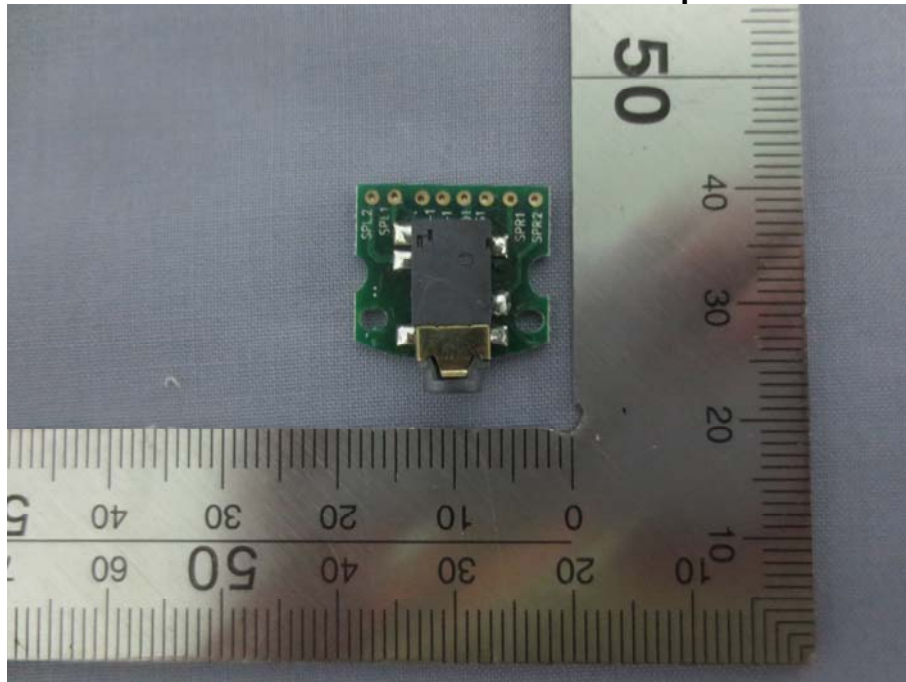

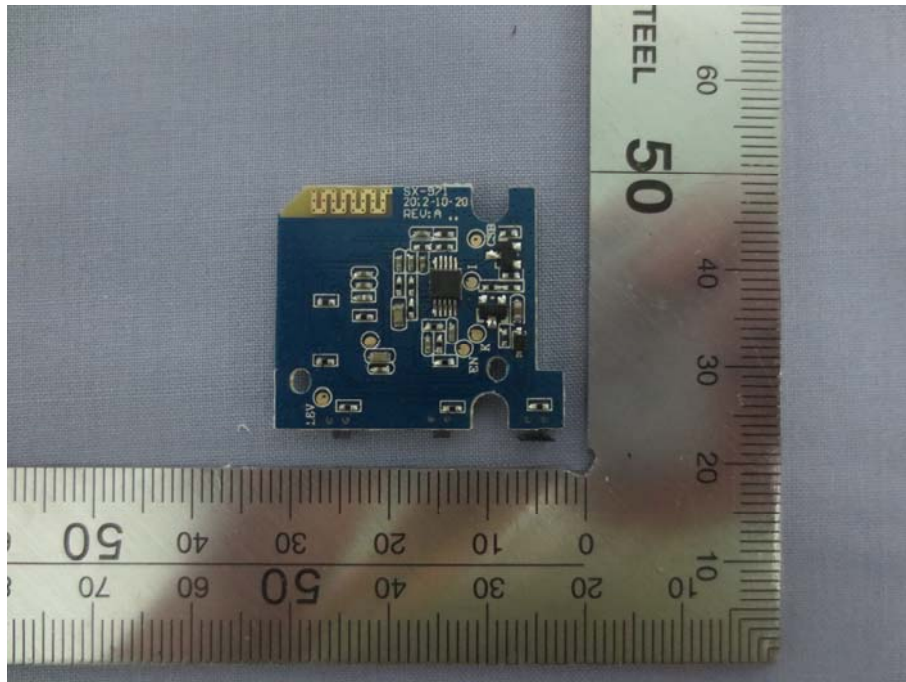
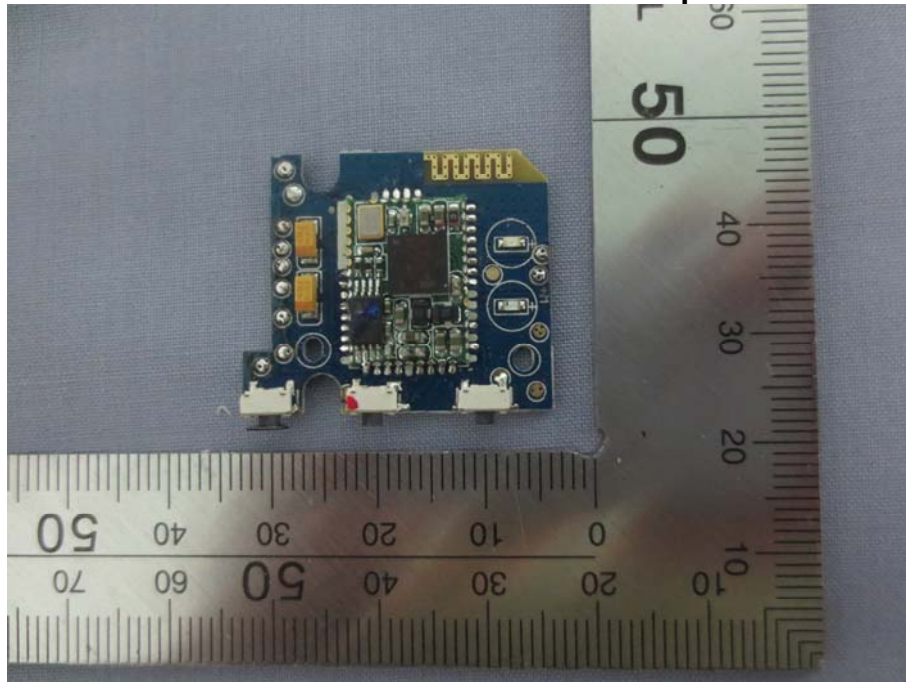

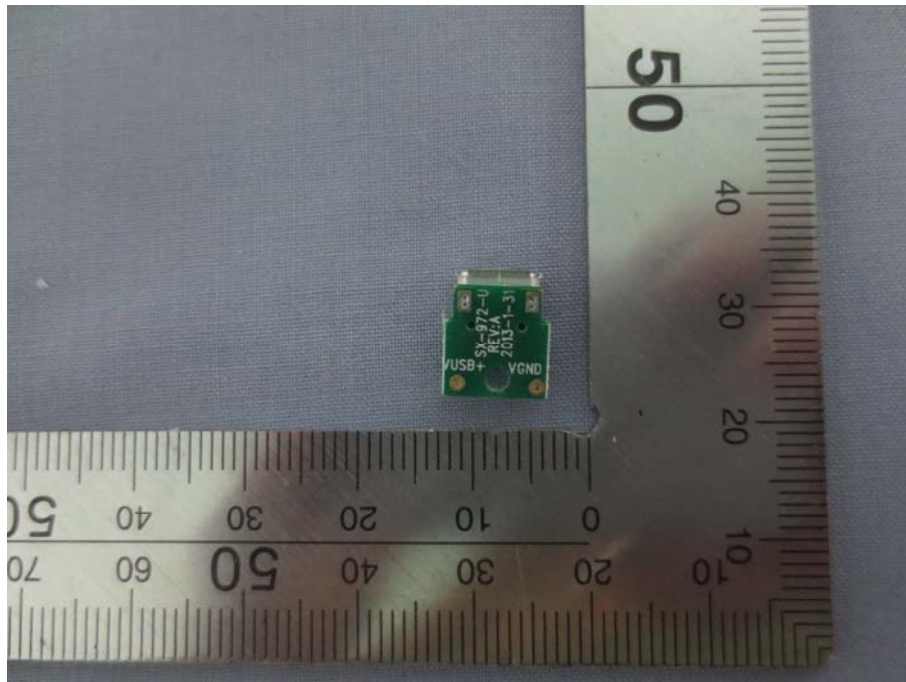
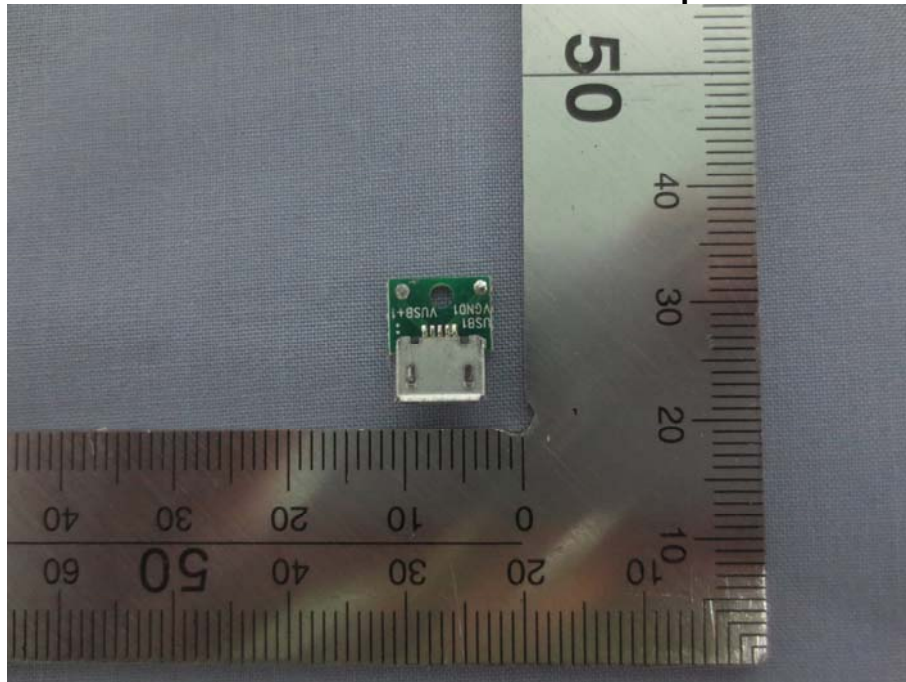

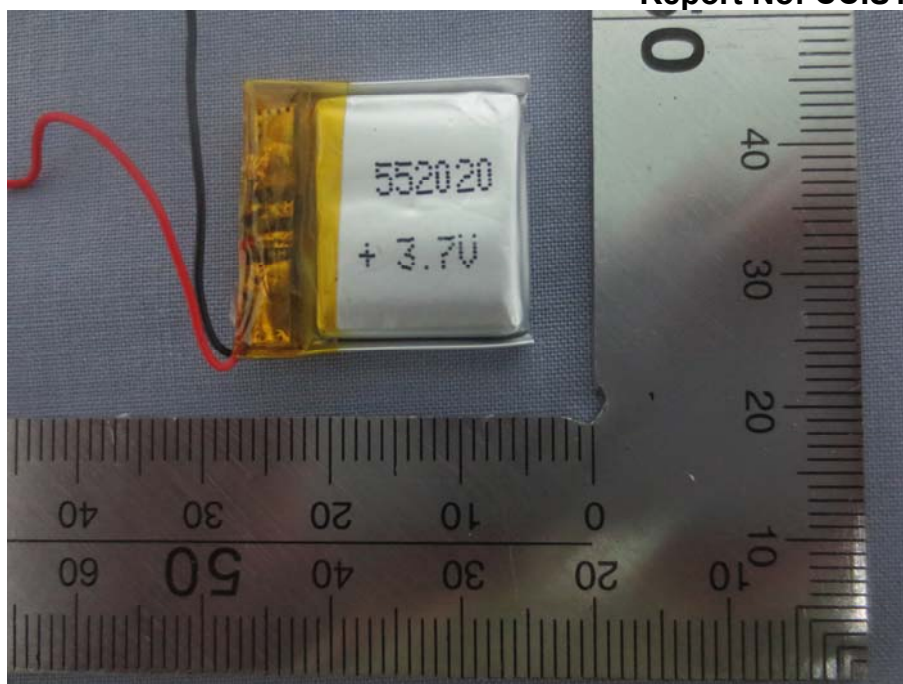

-----End of report-----