

	<u>Date(s) of Evaluation</u> Nov. 28, '07 - Jan. 16, '08	<u>Test Report Serial No.</u> 111507UGL-T876-S15WB	<u>Test Report Revision No.</u> Rev. 1.0 (Initial Release)	 Certificate No. 2470.01
	<u>Test Report Issue Date</u> March 11, 2008	<u>Description of Test(s)</u> Specific Absorption Rate	<u>RF Exposure Category</u> General Population	

APPENDIX F - SYSTEM VALIDATION

Applicant:	DRS Tactical Systems, Inc.	FCC ID:	UGL980026000WF	Model(s):	Armor X10	
DUT Type:	Tablet PC with Intel PRO/Wireless 3945ABG WLAN & Co-located MSI MS-6837D Bluetooth					
2008 Celltech Labs Inc.	This document is not to be reproduced in whole or in part without the prior written permission of Celltech Labs Inc.					Page 90 of 92

	Date of Evaluation:	June 08, 2007	Document Serial No.:	SV2450M-060807-R1.4	
	Evaluation Type:	System Validation	Validation Dipole:	2450 MHz	Fluid Type:

2450 MHz SYSTEM VALIDATION

Type:

2450 MHz Validation Dipole

Asset Number:

00025

Serial Number:

150

Place of Validation:

Celltech Labs Inc.

Date of Validation:

June 08, 2007

Celltech Labs Inc. certifies that the 2450 MHz System Validation was performed on the date indicated above.

Performed by:

Cheri Frangiadakis

Approved by:

Sean Johnston

1. Dipole Construction & Electrical Characteristics

The validation dipole was constructed in accordance with the requirements specified in IEEE Standard 1528-2003 and International Standard IEC 62209-1:2005. The electrical properties were measured using an HP 8753ET Network Analyzer. The network analyzer was calibrated to the validation dipole N-type connector feed point using an HP85032E Type N calibration kit. The dipole was placed parallel to a planar phantom at a separation distance of 10.0mm from the simulating fluid using a loss-less dielectric spacer. The measured input impedance is:

Feed point impedance at 2450 MHz $\text{Re}\{Z\} = 45.100\Omega$
 $\text{Im}\{Z\} = 3.5605\Omega$

Return Loss at 2450 MHz -23.411dB

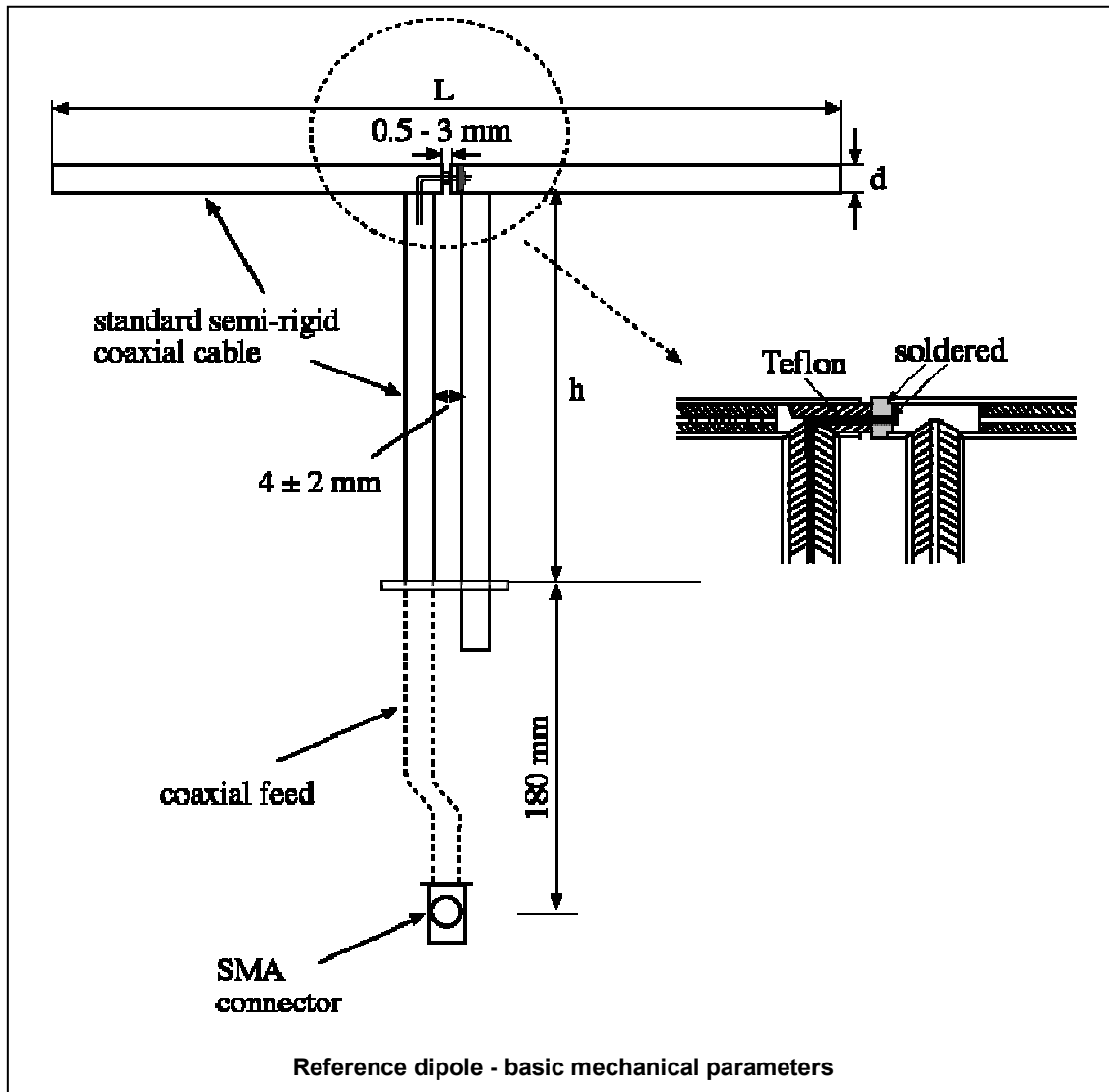

2. Validation Dipole VSWR Data

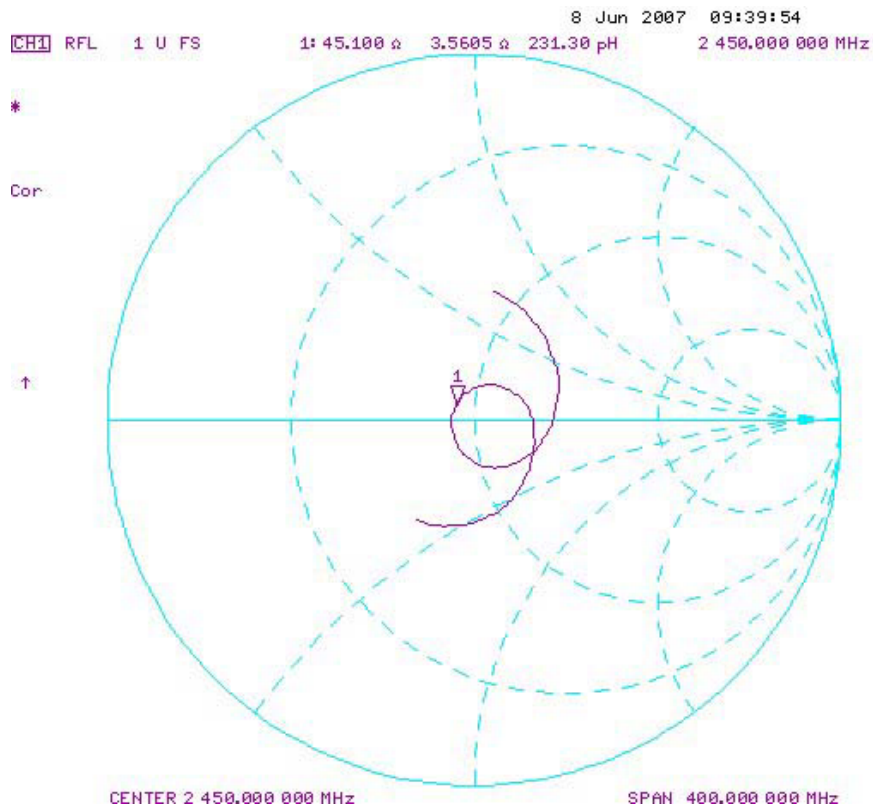
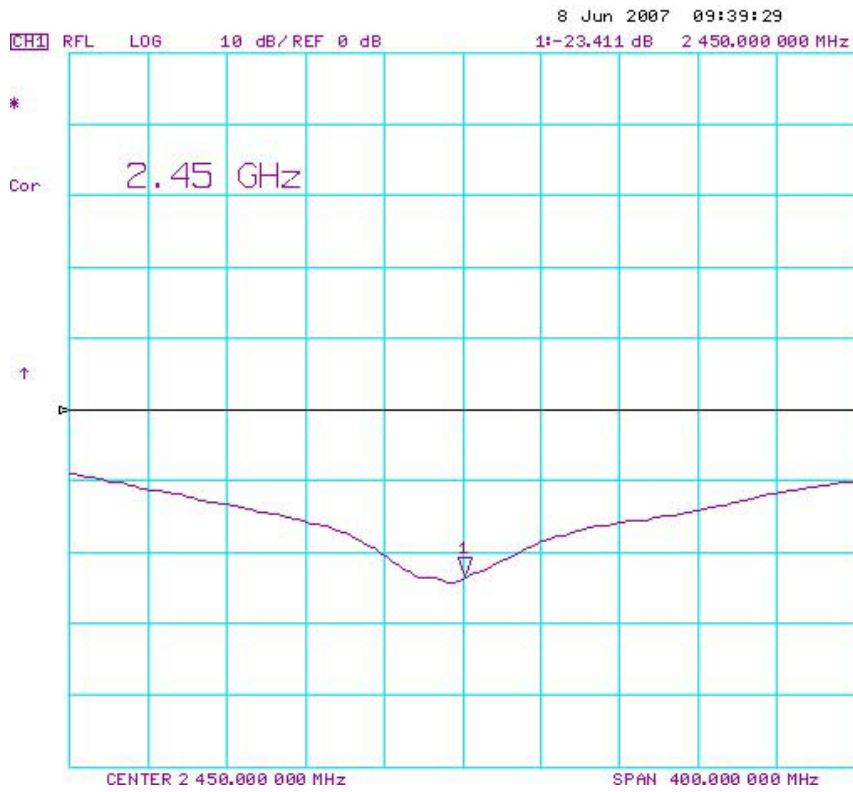

3. Validation Dipole Dimensions

Frequency (MHz)	L (mm)	H (mm)	D (mm)
300	396.0	250.0	6.0
450	270.0	167.0	6.0
835	161.0	89.8	3.6
900	149.0	83.3	3.6
1450	89.1	51.7	3.6
1800	72.0	41.7	3.6
1900	68.0	39.5	3.6
2000	64.5	37.5	3.6
2450	51.5	30.4	3.6
3000	41.5	25.0	3.6

4. Validation Phantom

The validation phantom is the SAM (Specific Anthropomorphic Mannequin) phantom manufactured by Schmid & Partner Engineering AG. The SAM phantom is a Fiberglass shell integrated in a wooden table. The shape of the shell corresponds to the phantom defined by SCC34-SC2. It enables the dosimetric evaluation of left and right hand phone usage as well as body mounted usage at the flat phantom region. A cover prevents evaporation of the liquid. Reference markings on the phantom allow the complete setup of all predefined phantom positions and measurement grids by manually teaching three points in the robot.

Shell Thickness: 2.0 ± 0.1 mm
Filling Volume: Approx. 25 liters
Dimensions: 50 cm (W) x 100 cm (L)



SAM Phantom



Fluid Depth (≥ 15.0 cm)

	Date of Evaluation:	June 08, 2007	Document Serial No.:	SV2450M-060807-R1.4	
	Evaluation Type:	System Validation	Validation Dipole:	2450 MHz	Fluid Type:

5. 2450 MHz System Validation Setup



	Date of Evaluation:	June 08, 2007	Document Serial No.:	SV2450M-060807-R1.4	
	Evaluation Type:	System Validation	Validation Dipole:	2450 MHz	Fluid Type:

6. 2450 MHz Validation Dipole Setup



7. SAR Measurement

Measurements were made at the planar section of the SAM phantom using a dosimetric E-field probe EX3DV4 (S/N: 3600, conversion factor 6.31). The SAR measurement was performed with the E-field probe in mechanical detection mode only. The setup and determination of the forward power into the dipole was performed using the procedures described below.

First the power meter PM1 (including attenuator Att1) is connected to the cable to measure the forward power at the location of the dipole connector (X). The signal generator is adjusted for the desired forward power at the dipole connector (taking into account the attenuation of Att1) as read by power meter PM2. After connecting the cable to the dipole, the signal generator is readjusted for the same reading at power meter PM2. If the signal generator does not allow adjustment in 0.01dB steps, the remaining difference at PM2 must be taken into consideration. PM3 records the reflected power from the dipole to ensure that the value is not changed from the previous value. The reflected power should be 20dB below the forward power.

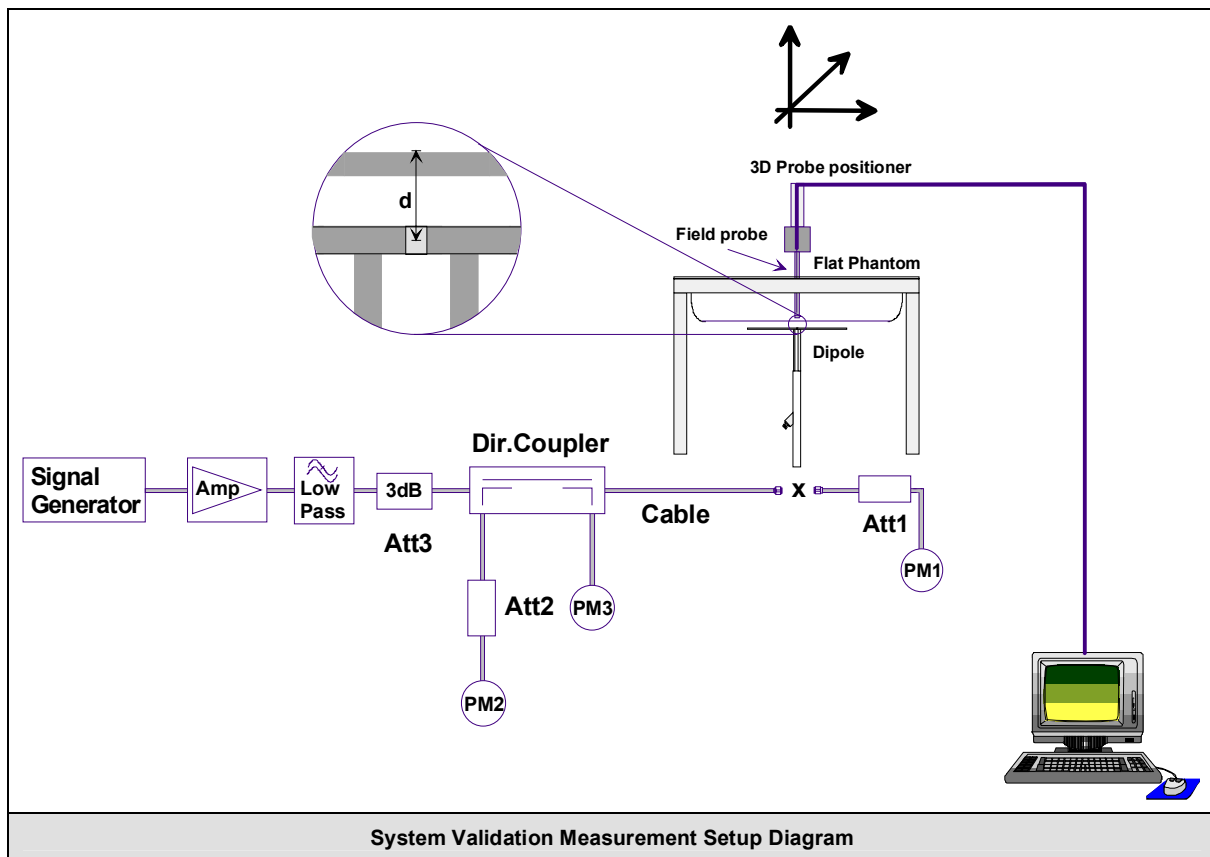

8. Measurement Conditions

The SAM phantom was filled with 2450 MHz Body tissue simulant.

Relative Permittivity: 50.1 (-4.9% deviation from target)
 Conductivity: 1.99 mho/m (+2.1% deviation from target)
 Fluid Temperature: 21.5 °C (Start of Test) / 21.2 °C (End of Test)
 Fluid Depth: ≥ 15.0 cm

Environmental Conditions:

Ambient Temperature: 22.7 °C
 Barometric Pressure: 101.1 kPa
 Humidity: 31 %

The 2450 MHz Body tissue simulant consisted of the following ingredients:

Ingredient	Percentage by weight	
Water	69.98%	
Glycol Monobutyl	30.00%	
Salt	0.02%	
IEEE Target Dielectric Parameters:	$\epsilon_r = 52.7 (+/-5\%)$	$\sigma = 1.95 \text{ S/m } (+/-5\%)$

9. System Validation SAR Results

SAR @ 0.25W Input averaged over 1g (W/kg)				SAR @ 1W Input averaged over 1g (W/kg)			
SPEAG Target		Measured	Deviation	SPEAG Target		Measured	Deviation
12.8	+/- 10%	13.4	+4.7%	51.2	+/- 10%	53.6	+4.7%
SAR @ 0.25W Input averaged over 10g (W/kg)				SAR @ 1W Input averaged over 10g (W/kg)			
SPEAG Target		Measured	Deviation	SPEAG Target		Measured	Deviation
5.93	+/- 10%	6.03	+1.7%	23.7	+/- 10%	24.1	+1.7%

Dipole Type	Distance [mm]	Frequency [MHz]	SAR (1g) [W/kg]	SAR (10g) [W/kg]	SAR (peak) [W/kg]
D300V2	15	300	3.02	2.06	4.36
D450V2	15	450	5.01	3.36	7.22
D835V2	15	835	9.71	6.38	14.1
D900V2	15	900	11.1	7.17	16.3
D1450V2	10	1450	29.6	16.6	49.8
D1500V2	10	1500	30.8	17.1	52.1
D1640V2	10	1640	34.4	18.7	59.4
D1800V2	10	1800	38.5	20.3	67.5
D1900V2	10	1900	39.8	20.8	69.6
D2000V2	10	2000	40.9	21.2	71.5
D2450V2	10	2450	51.2	23.7	97.6
D3000V2	10	3000	61.9	24.8	136.7

Table 32.1: Numerical reference SAR values for SPEAG dipoles and flat phantom filled with body-tissue simulating liquid. Note: All SAR values normalized to 1 W forward power.

	Date of Evaluation:	June 08, 2007	Document Serial No.:	SV2450M-060807-R1.4	
	Evaluation Type:	System Validation	Validation Dipole:	2450 MHz	Fluid Type:

System Validation - 2450 MHz Dipole - June 8, 2007

DUT: Dipole 2450 MHz; Asset: 00025; Serial: 150

Ambient Temp: 22.7°C; Fluid Temp: 21.5°C; Barometric Pressure: 101.1 kPa; Humidity: 31%

Communication System: CW

Forward Conducted Power: 250 mW

Frequency: 2450 MHz; Duty Cycle: 1:1

Medium: M2450 Medium parameters used: $f = 2450 \text{ MHz}$; $\sigma = 1.99 \text{ mho/m}$; $\epsilon_r = 50.1$; $\rho = 1000 \text{ kg/m}^3$

- Probe: EX3DV4 - SN3600; ConvF(6.31, 6.31, 6.31); Calibrated: 24/01/2007
- Sensor-Surface: 2 mm (Mechanical Surface Detection)
- Electronics: DAE4 Sn353; Calibrated: 21/06/2006
- Phantom: SAM 4.0; Type: Fiberglass; Serial: 1033
- Measurement SW: DASY4, V4.7 Build 44; Postprocessing SW: SEMCAD, V1.8 Build 171

2450 MHz System Validation/Area Scan (6x10x1):

Measurement grid: $dx=10\text{mm}$, $dy=10\text{mm}$

Maximum value of SAR (measured) = 13.1 mW/g

2450 MHz System Validation/Zoom Scan (7x7x7)/Cube 0:

Measurement grid: $dx=5\text{mm}$, $dy=5\text{mm}$, $dz=5\text{mm}$

Reference Value = 91.9 V/m; Power Drift = -0.128 dB

Peak SAR (extrapolated) = 28.6 W/kg

SAR(1 g) = 13.4 mW/g; SAR(10 g) = 6.03 mW/g

Maximum value of SAR (measured) = 15.5 mW/g

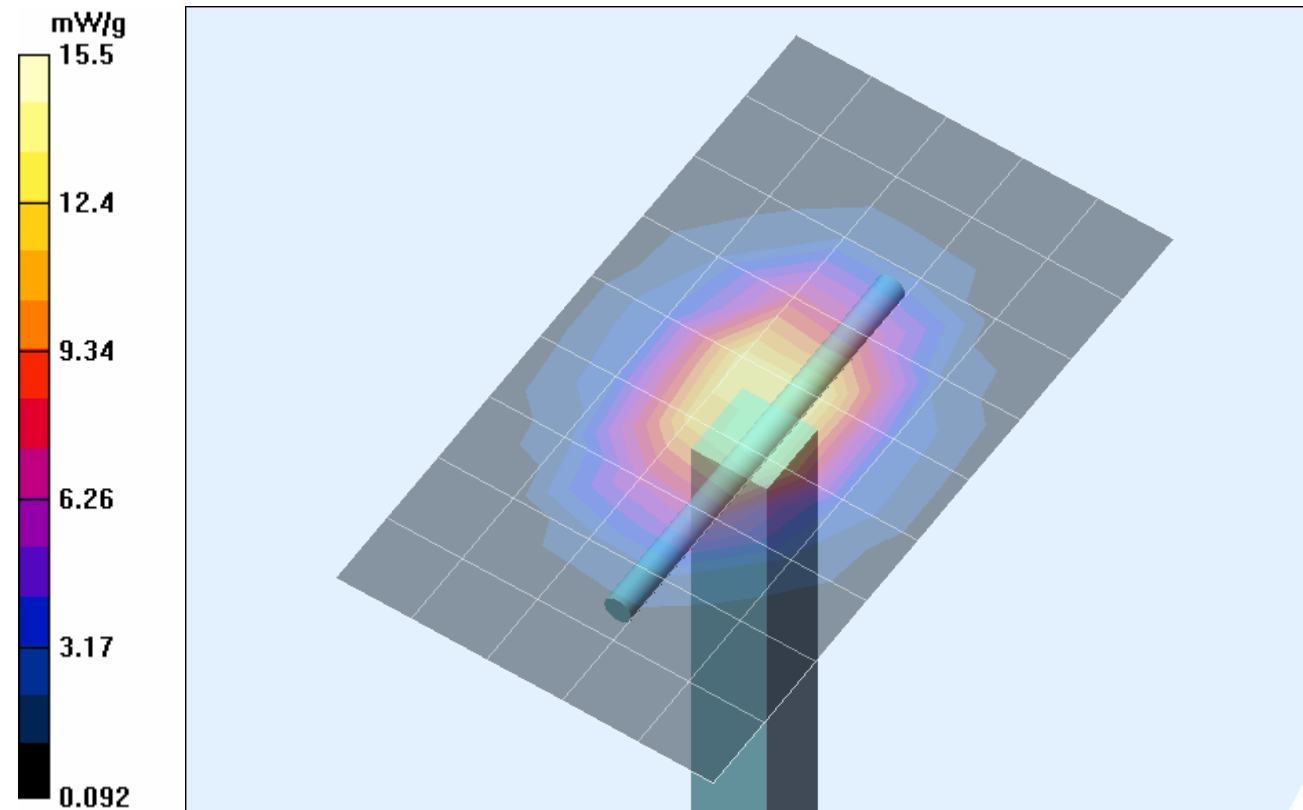

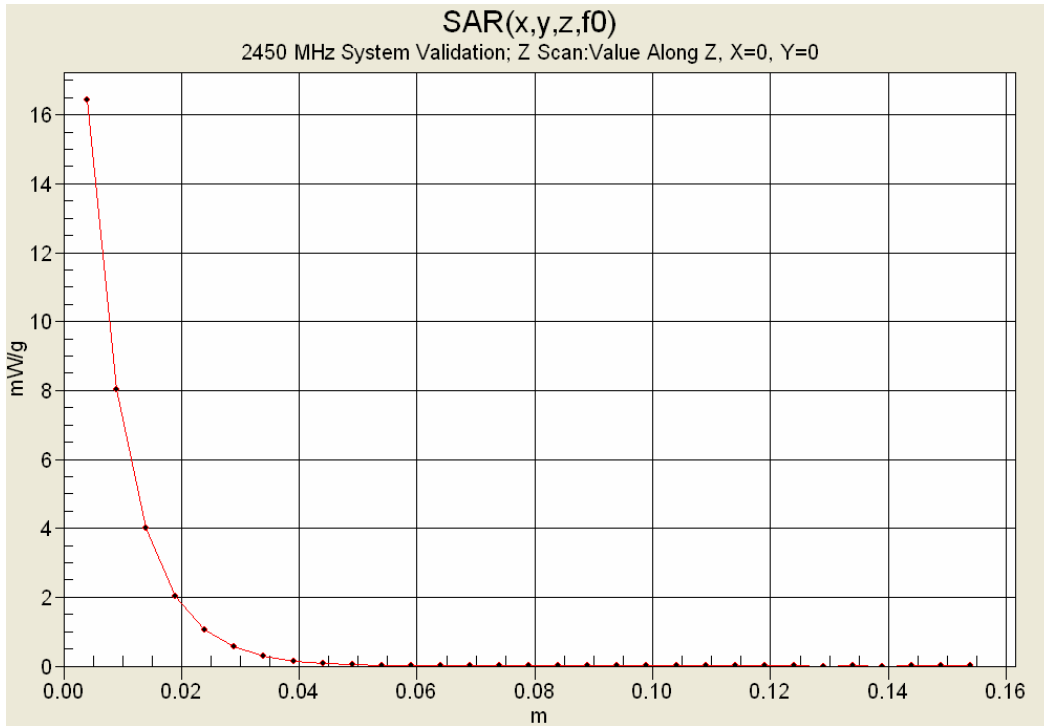

10. Measured Fluid Dielectric Parameters

System Validation - 2450 MHz (Body)

Celltech Labs Inc.

Test Result for UIM Dielectric Parameter

Fri 08/Jun/2007

Frequency (GHz)

FCC_eH FCC Bulletin 65 Supplement C (June 2001) Limits for Head Epsilon

FCC_sH FCC Bulletin 65 Supplement C (June 2001) Limits for Head Sigma

FCC_eB FCC Limits for Body Epsilon

FCC_sB FCC Limits for Body Sigma

Test_e Epsilon of UIM

Test_s Sigma of UIM

Freq	FCC_eB	FCC_sB	Test_e	Test_s
2.3500	52.83	1.85	50.39	1.89
2.3600	52.82	1.86	50.32	1.90
2.3700	52.81	1.87	50.28	1.91
2.3800	52.79	1.88	50.28	1.93
2.3900	52.78	1.89	50.31	1.94
2.4000	52.77	1.90	50.26	1.95
2.4100	52.75	1.91	50.24	1.96
2.4200	52.74	1.92	50.21	1.96
2.4300	52.73	1.93	50.21	1.98
2.4400	52.71	1.94	50.13	1.99
2.4500	52.70	1.95	50.09	1.99
2.4600	52.69	1.96	50.01	2.03
2.4700	52.67	1.98	50.10	2.03
2.4800	52.66	1.99	50.12	2.05
2.4900	52.65	2.01	50.09	2.07
2.5000	52.64	2.02	50.08	2.07
2.5100	52.62	2.04	50.03	2.08
2.5200	52.61	2.05	50.02	2.09
2.5300	52.60	2.06	49.93	2.10
2.5400	52.59	2.08	49.87	2.11
2.5500	52.57	2.09	49.78	2.13

11. Measurement Uncertainties

UNCERTAINTY BUDGET FOR SYSTEM VALIDATION						
Error Description	Uncertainty Value ±%	Probability Distribution	Divisor	ci 1g	Uncertainty Value ±% (1g)	V _i or V _{eff}
Measurement System						
Probe calibration (2450 MHz)	5.9	Normal	1	1	5.9	∞
Axial isotropy of the probe	4.7	Rectangular	1.732050808	1	2.7	∞
Spherical isotropy of the probe	0	Rectangular	1.732050808	1	0.0	∞
Spatial resolution	0	Rectangular	1.732050808	1	0.0	∞
Boundary effects	0.2	Rectangular	1.732050808	1	0.1	∞
Probe linearity	4.7	Rectangular	1.732050808	1	2.7	∞
Detection limit	1	Rectangular	1.732050808	1	0.6	∞
Readout electronics	0.3	Normal	1	1	0.3	∞
Response time	0	Rectangular	1.732050808	1	0.0	∞
Integration time	0	Rectangular	1.732050808	1	0.0	∞
RF ambient conditions	3	Rectangular	1.732050808	1	1.7	∞
Mech. constraints of robot	0.4	Rectangular	1.732050808	1	0.2	∞
Probe positioning	2.9	Rectangular	1.732050808	1	1.7	∞
Extrapolation & integration	1	Rectangular	1.732050808	1	0.6	∞
Dipole						
Dipole Positioning	2	Normal	1.732050808	1	1.2	∞
Power & Power Drift	4.7	Normal	1.732050808	1	2.7	∞
Phantom and Setup						
Phantom uncertainty	4	Rectangular	1.732050808	1	2.3	∞
Liquid conductivity (target)	5	Rectangular	1.732050808	0.64	1.8	∞
Liquid conductivity (measured)	2.1	Normal	1	0.64	1.3	∞
Liquid permittivity (target)	5	Rectangular	1.732050808	0.6	1.7	∞
Liquid permittivity (measured)	4.9	Normal	1	0.6	2.9	∞
Combined Standard Uncertainty					9.33	
Expanded Uncertainty (k=2)					18.66	
Measurement Uncertainty Table in accordance with IEEE Standard 1528-2003 and IEC Standard 62209-1:2005						

12. Test Equipment List

TEST EQUIPMENT	ASSET NO.	SERIAL NO.	DATE OF CAL.	CAL. DUE DATE
SPEAG DASY4 Measurement Server	00158	1078	N/A	N/A
SPEAG Robot	00046	599396-01	N/A	N/A
SPEAG DAE4	00019	353	21Jun06	21Jun07
SPEAG EX3DV4 E-Field Probe	00213	3600	24Jan07	24Jan08
2450 MHz Validation Dipole	00025	150	08Jun07	08Jun08
SPEAG SAM Phantom V4.0C	00154	1033	N/A	N/A
ALS-PR-DIEL Dielectric Probe Kit	00160	260-00953	N/A	N/A
Gigatronics 8652A Power Meter	00007	1835272	26Mar07	26Mar08
Gigatronics 80701A Power Sensor	00014	1833699	22Jan07	22Jan08
Gigatronics 80701A Power Sensor	00109	1834366	26Mar07	26Mar08
HP 8753ET Network Analyzer	00134	US39170292	20Apr07	20Apr08
HP 8648D Signal Generator	00005	3847A00611	NCR	NCR
Amplifier Research 5S1G4 Power Amplifier	00106	26235	NCR	NCR

	Date of Evaluation:	May 18, 2007	Document Serial No.:	SV5200M-051807-R1.2	
	Evaluation Type:	System Validation	Validation Dipole:	5200 MHz	Fluid Type:

5200 MHz SYSTEM VALIDATION

Type: **5200 MHz Validation Dipole**

Asset Number: **00126**

Serial Number: **1031**

Place of Validation: **Celltech Labs Inc.**

Date of Validation: **May 18, 2007**

Celltech Labs Inc. certifies that the 5200 MHz System Validation was performed on the date indicated above.

Performed by: **Cheri Frangiadakis**

Approved by: **Sean Johnston**

	Date of Evaluation:	May 18, 2007	Document Serial No.:	SV5200M-051807-R1.2
	Evaluation Type:	System Validation	Validation Dipole:	5200 MHz
			Fluid Type:	Body

1. Dipole Construction & Electrical Characteristics

The validation dipole was manufactured by Schmid and Partner Engineering AG. The electrical properties were measured using an HP 8753ET Network Analyzer. The network analyzer was calibrated to the validation dipole N-type connector feed point using an HP85032E Type N calibration kit. The dipole was placed parallel to a planar phantom at a separation distance of 10.0mm from the simulating fluid using a loss-less dielectric spacer. The measured input impedance is:

Feed point impedance at 5200 MHz $\text{Re}\{Z\} = 50.324\Omega$
 $\text{Im}\{Z\} = 3.5215\Omega$

Return Loss at 5200 MHz -28.311 dB

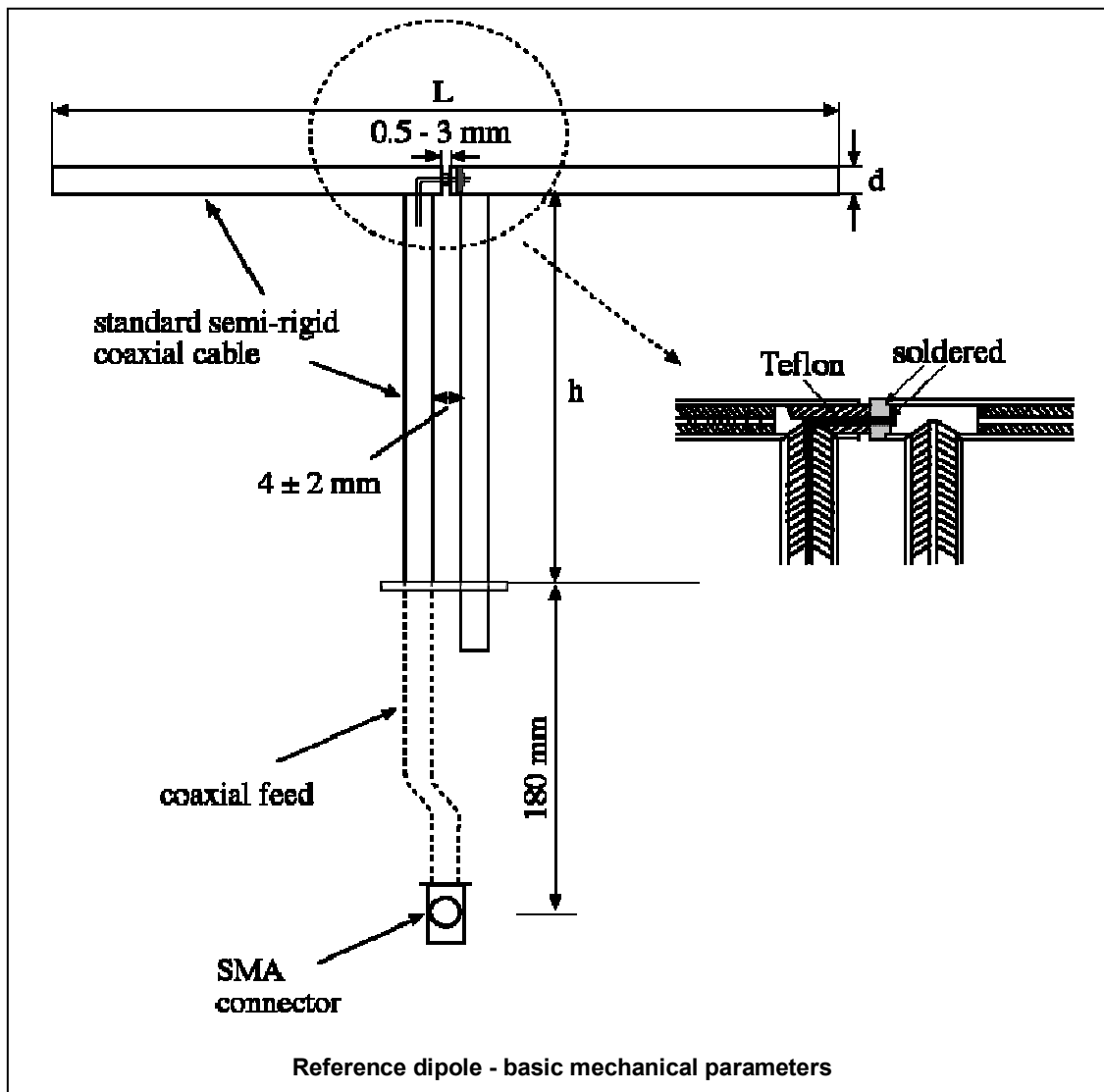

2. Validation Dipole VSWR Data

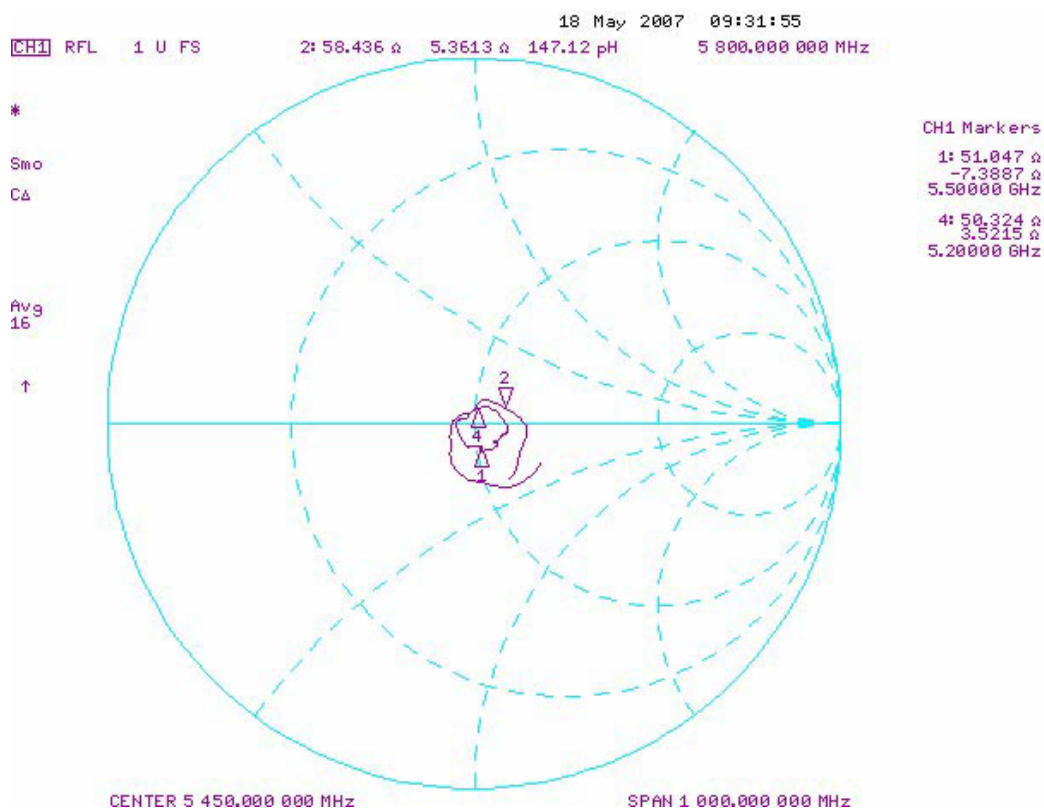
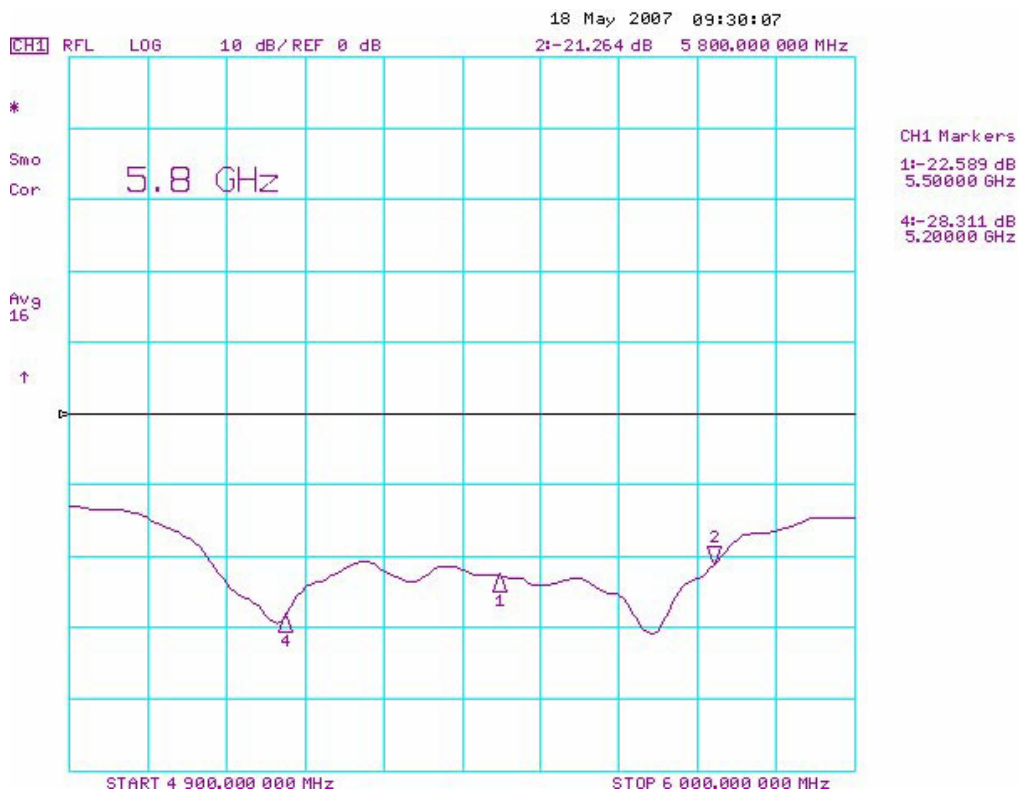

3. Validation Dipole Dimensions

Frequency (MHz)	L (mm)	H (mm)	D (mm)
300	396.0	250.0	6.0
450	270.0	167.0	6.0
835	161.0	89.8	3.6
900	149.0	83.3	3.6
1450	89.1	51.7	3.6
1800	72.0	41.7	3.6
1900	68.0	39.5	3.6
2000	64.5	37.5	3.6
2450	51.5	30.4	3.6
3000	41.5	25.0	3.6
5200 - 5800	20.6	40.65	3.6

4. Validation Phantom

The validation phantom is the SAM (Specific Anthropomorphic Mannequin) phantom manufactured by Schmid & Partner Engineering AG. The SAM phantom is a Fiberglass shell integrated in a wooden table. The shape of the shell corresponds to the phantom defined by SCC34-SC2. It enables the dosimetric evaluation of left and right hand phone usage as well as body mounted usage at the flat phantom region. A cover prevents evaporation of the liquid. Reference markings on the phantom allow the complete setup of all predefined phantom positions and measurement grids by manually teaching three points in the robot.

Shell Thickness: 2.0 ± 0.1 mm

Filling Volume: Approx. 25 liters

Dimensions: 50 cm (W) x 100 cm (L)

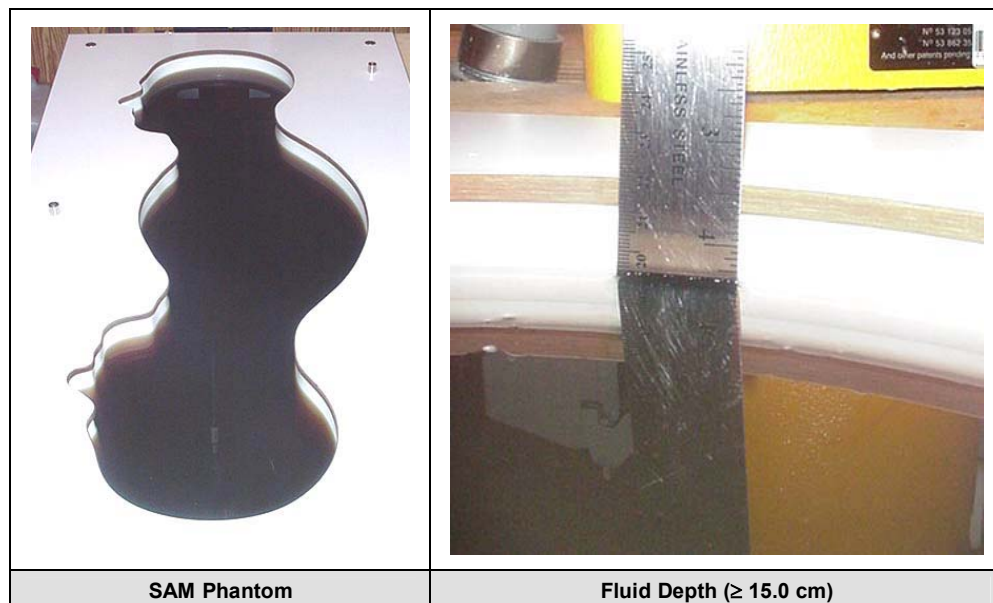

	Date of Evaluation:	May 18, 2007	Document Serial No.:	SV5200M-051807-R1.2	
	Evaluation Type:	System Validation	Validation Dipole:	5200 MHz	Fluid Type:

5. 5200 MHz System Validation Setup



	Date of Evaluation:	May 18, 2007	Document Serial No.:	SV5200M-051807-R1.2		
	Evaluation Type:	System Validation	Validation Dipole:	5200 MHz	Fluid Type:	Body

6. 5200 MHz Validation Dipole Setup



7. SAR Measurement

Measurements were made using a dosimetric E-field probe EX3DV4 (S/N: 3600, Conversion Factor 4.10). The SAR measurement was performed with the E-field probe in mechanical detection mode only. The setup and determination of the forward power into the dipole was performed using the procedures described below.

First the power meter PM1 (including attenuator Att1) is connected to the cable to measure the forward power at the location of the dipole connector (X). The signal generator is adjusted for the desired forward power at the dipole connector (taking into account the attenuation of Att1) as read by power meter PM2. After connecting the cable to the dipole, the signal generator is readjusted for the same reading at power meter PM2. If the signal generator does not allow adjustment in 0.01dB steps, the remaining difference at PM2 must be taken into consideration. PM3 records the reflected power from the dipole to ensure that the value is not changed from the previous value. The reflected power should be 20dB below the forward power.

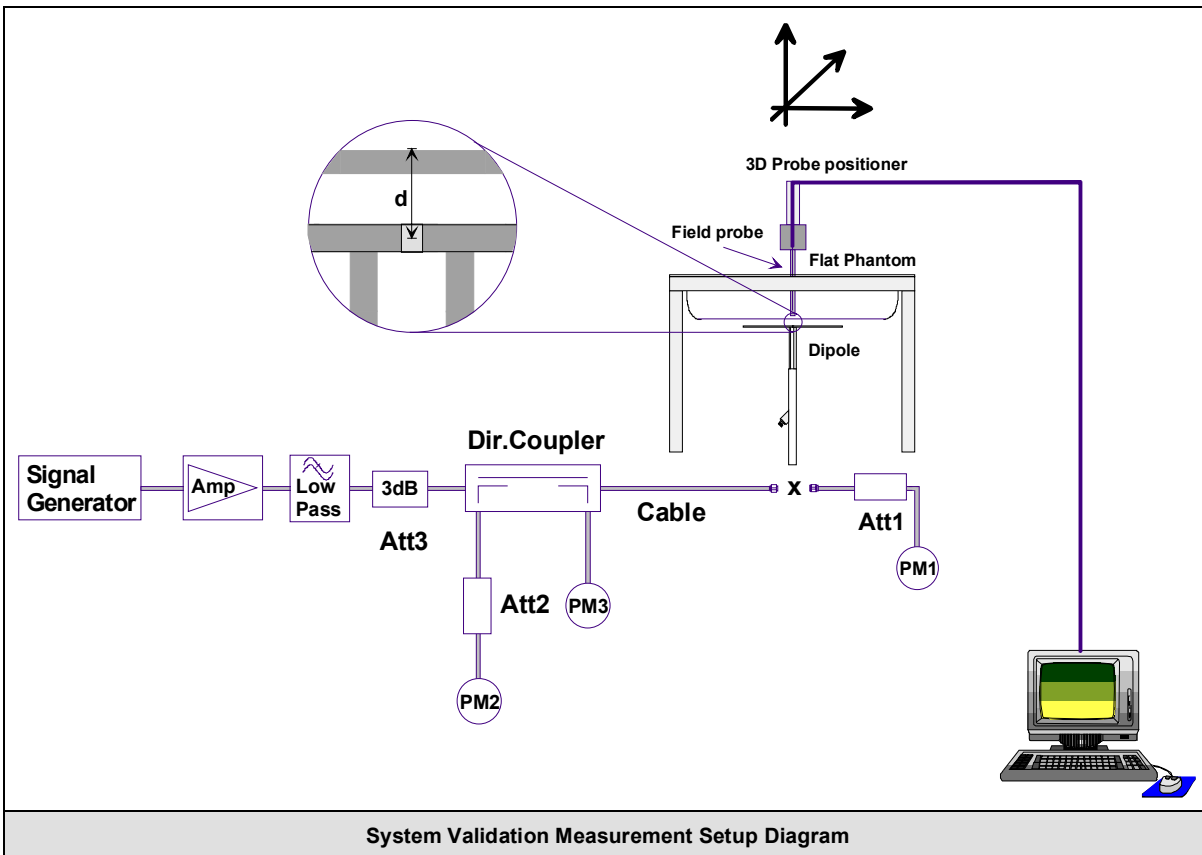

8. Measurement Conditions

The SAM phantom was filled with 5200 MHz Body tissue simulant.

Relative Permittivity: 44.6 (-9.0% deviation from target)
 Conductivity: 5.52 mho/m (+4.2% deviation from target)
 Fluid Temperature: 23.6 °C (Start of Test) / 23.7 °C (End of Test)
 Fluid Depth: ≥ 15.0 cm

Environmental Conditions:

Ambient Temperature: 25.0°C
 Humidity: 48%
 Barometric Pressure: 101.1 kPa

The 5200 MHz Body tissue simulant consisted of the following ingredients:

Ingredient	Percentage by weight
Water	64 - 78%
Mineral Oil	11 - 18%
Emulsifiers	9 - 15%
Additives and Salt	2 - 3%
IEEE Target Dielectric Parameters:	$\epsilon_r = 49.0$ (+/-10%) $\sigma = 5.30$ S/m (+/-5%)

9. System Validation SAR Results

SAR @ 0.25W Input averaged over 1g (W/kg)				SAR @ 1W Input averaged over 1g (W/kg)			
SPEAG Target		Measured	Deviation	SPEAG Target		Measured	Deviation
18.0	+/- 10%	18.2	+1.2%	72.0	+/- 10%	72.8	+1.1%
SAR @ 0.25W Input averaged over 10g (W/kg)				SAR @ 1W Input averaged over 10g (W/kg)			
SPEAG Target		Measured	Deviation	SPEAG Target		Measured	Deviation
5.03	+/- 10%	5.12	+1.8%	20.12	+/- 10%	20.48	+1.8%
Extrapolated Peak SAR	SPEAG Target	71.2	+/- 15%	Measured	72.7	+2.1%	

Reference SAR values

The reference SAR values were calculated using finite-difference time-domain FDTD method (feed-point impedance set to 50 Ω) and the mechanical dimensions of the D5GHzV2 dipole (manufactured by SPEAG).

f (GHz)	Head Tissue			Body Tissue		
	SAR_{1g}	SAR_{10g}	SAR_{peak}	SAR_{1g}	SAR_{10g}	SAR_{peak}
5.0	72.9	20.7	285.6	68.1	19.2	260.3
5.1	74.6	21.1	297.5	78.8	19.6	272.3
5.2	76.5	21.6	310.3	71.8	20.1	284.7
5.5	83.3	23.4	349.4	79.1	22.0	326.3
5.8	78.0	21.9	340.9	74.1	20.5	324.7

Table 27.2: Numerical reference SAR values for D5GHzV2 dipole and flat phantom.

	Date of Evaluation:	May 18, 2007	Document Serial No.:	SV5200M-051807-R1.2
	Evaluation Type:	System Validation	Validation Dipole:	5200 MHz
			Fluid Type:	Body

System Validation - 5200 MHz Dipole - May 18, 2007

DUT: Dipole 5GHz; Model: D5GHzV2; Asset: 00126; Serial: 1031

Ambient Temp: 25.0°C; Fluid Temp: 23.6°C; Barometric Pressure: 101.1 kPa; Humidity: 48%

Communication System: CW

Forward Conducted Power: 250mW

Frequency: 5200 MHz; Duty Cycle: 1:1

Medium: M5200-5800 Medium parameters used: $f = 5200$ MHz; $\sigma = 5.52$ mho/m; $\epsilon_r = 44.6$; $\rho = 1000$ kg/m³

- Probe: EX3DV4 - SN3600; ConvF(4.1, 4.1, 4.1); Calibrated: 24/01/2007
- Sensor-Surface: 2 mm (Mechanical Surface Detection)
- Electronics: DAE4 Sn353; Calibrated: 21/06/2006
- Phantom: SAM 4.0; Type: Fibreglas; Serial: 1033
- Measurement SW: DASY4, V4.7 Build 44; Postprocessing SW: SEMCAD, V1.8 Build 171

5200 MHz System Validation/Area Scan (9x13x1):

Measurement grid: dx=5mm, dy=5mm

Maximum value of SAR (measured) = 48.3 mW/g

5200 MHz System Validation/Zoom Scan (7x7x9)/Cube 0:

Measurement grid: dx=4mm, dy=4mm, dz=2.5mm

Reference Value = 86.3 V/m; Power Drift = 0.100 dB

Peak SAR (extrapolated) = 72.7 W/kg

SAR(1 g) = 18.2 mW/g; SAR(10 g) = 5.12 mW/g

Maximum value of SAR (measured) = 36.1 mW/g

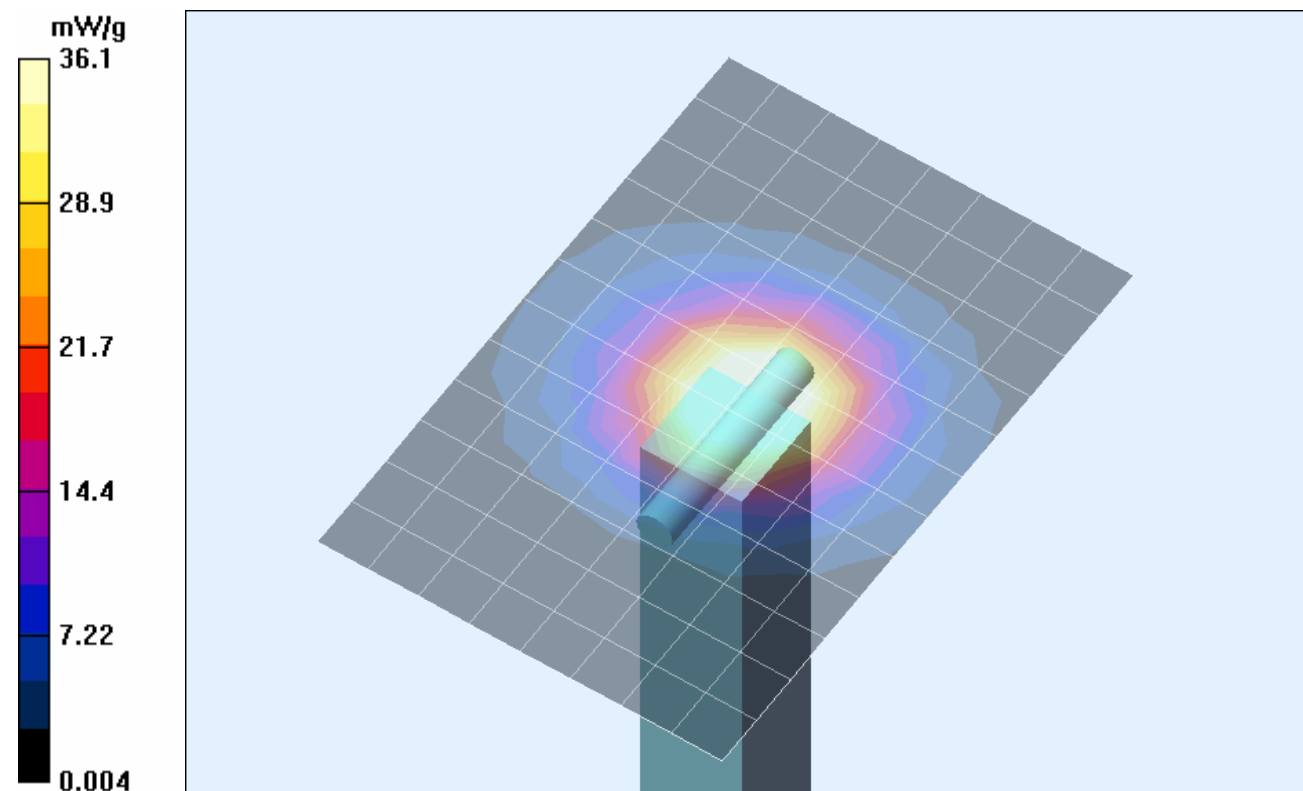

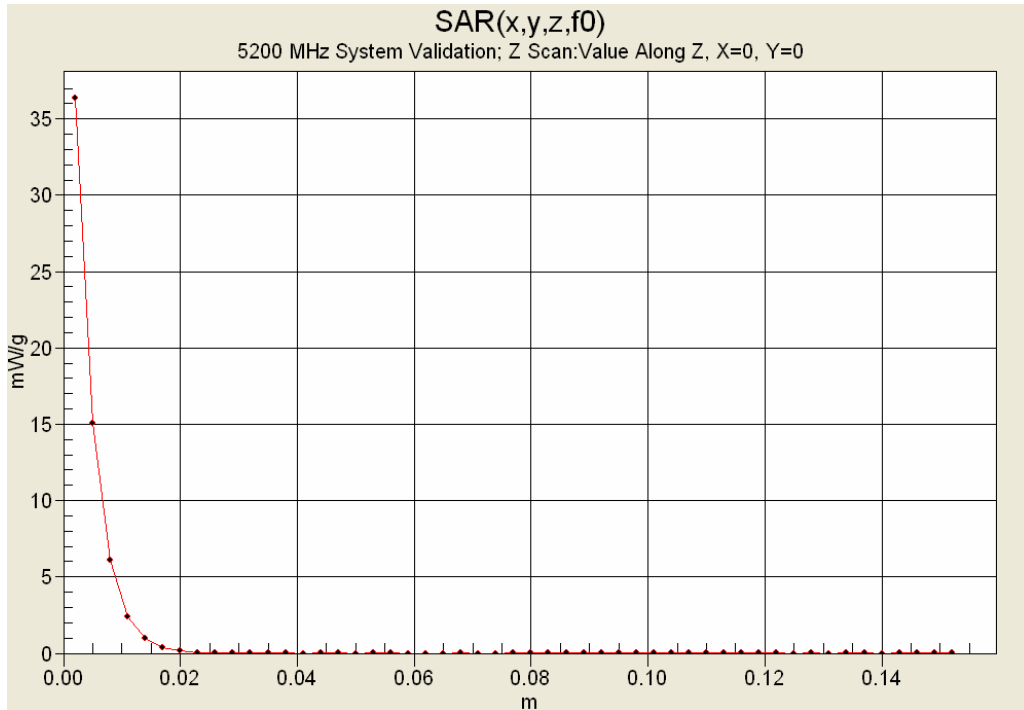

10. Measured Fluid Dielectric Parameters

System Validation - 5200 MHz (Body)

Celltech Labs Inc.

Test Result for UIM Dielectric Parameter

Tue 18/May/2007

Frequency (GHz)

FCC_eH FCC Bulletin 65 Supplement C (June 2001) Limits for Head Epsilon

FCC_sH FCC Bulletin 65 Supplement C (June 2001) Limits for Head Sigma

FCC_eB FCC Limits for Body Epsilon

FCC_sB FCC Limits for Body Sigma

Test_e Epsilon of UIM

Test_s Sigma of UIM

Freq	FCC_eB	FCC_sB	Test_e	Test_s
5.1000	49.15	5.18	44.46	5.40
5.1100	49.14	5.19	44.42	5.39
5.1200	49.12	5.21	44.40	5.36
5.1300	49.11	5.22	44.40	5.40
5.1400	49.10	5.23	44.38	5.39
5.1500	49.08	5.24	44.37	5.38
5.1600	49.07	5.25	44.46	5.44
5.1700	49.06	5.26	44.35	5.46
5.1800	49.04	5.28	44.31	5.47
5.1900	49.03	5.29	44.38	5.51
5.2000	49.01	5.30	44.55	5.52
5.2100	49.00	5.31	44.40	5.53
5.2200	48.99	5.32	44.23	5.48
5.2300	48.97	5.33	44.20	5.51
5.2400	48.96	5.35	44.14	5.54
5.2500	48.95	5.36	44.15	5.58
5.2600	48.93	5.37	44.19	5.56
5.2700	48.92	5.38	44.16	5.57
5.2800	48.91	5.39	44.01	5.59
5.2900	48.89	5.40	44.00	5.62
5.3000	48.88	5.42	43.98	5.63

11. Measurement Uncertainties

UNCERTAINTY BUDGET FOR SYSTEM VALIDATION						
Error Description	Uncertainty Value ±%	Probability Distribution	Divisor	ci 1g	Uncertainty Value ±% (1g)	V _i or V _{eff}
Measurement System						
Probe calibration (5200 MHz)	6.55	Normal	1	1	6.55	∞
Axial isotropy of the probe	4.7	Rectangular	1.732050808	1	2.7	∞
Spherical isotropy of the probe	9.6	Rectangular	1.732050808	1	5.5	∞
Spatial resolution	0	Rectangular	1.732050808	1	0.0	∞
Boundary effects	0.1	Rectangular	1.732050808	1	0.1	∞
Probe linearity	4.7	Rectangular	1.732050808	1	2.7	∞
Detection limit	1	Rectangular	1.732050808	1	0.6	∞
Readout electronics	0.3	Normal	1	1	0.3	∞
Response time	0	Rectangular	1.732050808	1	0.0	∞
Integration time	0	Rectangular	1.732050808	1	0.0	∞
RF ambient conditions	3	Rectangular	1.732050808	1	1.7	∞
Mech. constraints of robot	0.8	Rectangular	1.732050808	1	0.5	∞
Probe positioning	5.7	Rectangular	1.732050808	1	3.3	∞
Extrapolation & integration	4	Rectangular	1.732050808	1	2.3	∞
Dipole						
Dipole positioning	2	Rectangular	1.732050808	1	1.2	∞
Power & Power Drift	4.7	Rectangular	1.732050808	1	2.7	∞
Phantom and Setup						
Phantom uncertainty	4	Rectangular	1.732050808	1	2.3	∞
Liquid conductivity (target)	5	Rectangular	1.732050808	0.64	1.8	∞
Liquid conductivity (measured)	4.2	Normal	1	0.64	2.7	∞
Liquid permittivity (target)	10	Rectangular	1.732050808	0.6	3.5	∞
Liquid permittivity (measured)	9	Normal	1	0.6	5.4	∞
Combined Standard Uncertainty					13.19	
Expanded Uncertainty (k=2)					26.38	
Measurement Uncertainty Table in accordance with IEEE Standard 1528-2003 and IEC Standard 62209-1:2005						

12. Test Equipment List

TEST EQUIPMENT	ASSET NO.	SERIAL NO.	DATE OF CAL.	CAL. DUE DATE
SPEAG DASY4 Measurement Server	00158	1078	N/A	N/A
SPEAG Robot	00046	599396-01	N/A	N/A
SPEAG DAE4	00019	353	21Jun06	21Jun07
SPEAG EX3DV4 E-Field Probe	00213	3600	24Jan07	24Jan08
SPEAG 5GHz Validation Dipole	00126	1031	09May07	09May08
SPEAG SAM Phantom V4.0C	00154	1033	N/A	N/A
ALS-PR-DIEL Dielectric Probe Kit	00160	260-00953	N/A	N/A
Gigatronics 8652A Power Meter	00007	1835272	26Mar07	26Mar08
Gigatronics 80701A Power Sensor	00014	1833699	22Jan07	22Jan08
Gigatronics 80701A Power Sensor	00109	1834366	26Mar07	26Mar08
HP 8753ET Network Analyzer	00134	US39170292	20Apr07	20Apr08
Nextec NB00383 Microwave Amplifier	00151	0535	NCR	NCR
Rohde & Schwarz SMR20 Signal Generator	00006	100104	NCR	NCR

	Date of Evaluation:	May 10, 2007	Document Serial No.:	SV5800M-051007-R1.2	
	Evaluation Type:	System Validation	Validation Dipole:	5800 MHz	Fluid Type:

5800 MHz SYSTEM VALIDATION

Type: **5800 MHz Validation Dipole**

Asset Number: **00126**

Serial Number: **1031**

Place of Validation: **Celltech Labs Inc.**

Date of Validation: **May 10, 2007**

Celltech Labs Inc. certifies that the 5800 MHz System Validation was performed on the date indicated above.

Performed by: **Cheri Frangiadakis**

Approved by: **Sean Johnston**

	Date of Evaluation:	May 10, 2007	Document Serial No.:	SV5800M-051007-R1.2
	Evaluation Type:	System Validation	Validation Dipole:	5800 MHz
			Fluid Type:	Body

1. Dipole Construction & Electrical Characteristics

The validation dipole was manufactured by Schmid and Partner Engineering AG. The electrical properties were measured using an HP 8753ET Network Analyzer. The network analyzer was calibrated to the validation dipole N-type connector feed point using an HP85032ET Type N calibration kit. The dipole was placed parallel to a planar phantom at a separation distance of 10.0mm from the simulating fluid using a loss-less dielectric spacer. The measured input impedance is:

Feed point impedance at 5800 MHz $\text{Re}\{Z\} = 58.436\Omega$
 $\text{Im}\{Z\} = 5.3613\Omega$

Return Loss at 5800 MHz -21.264 dB

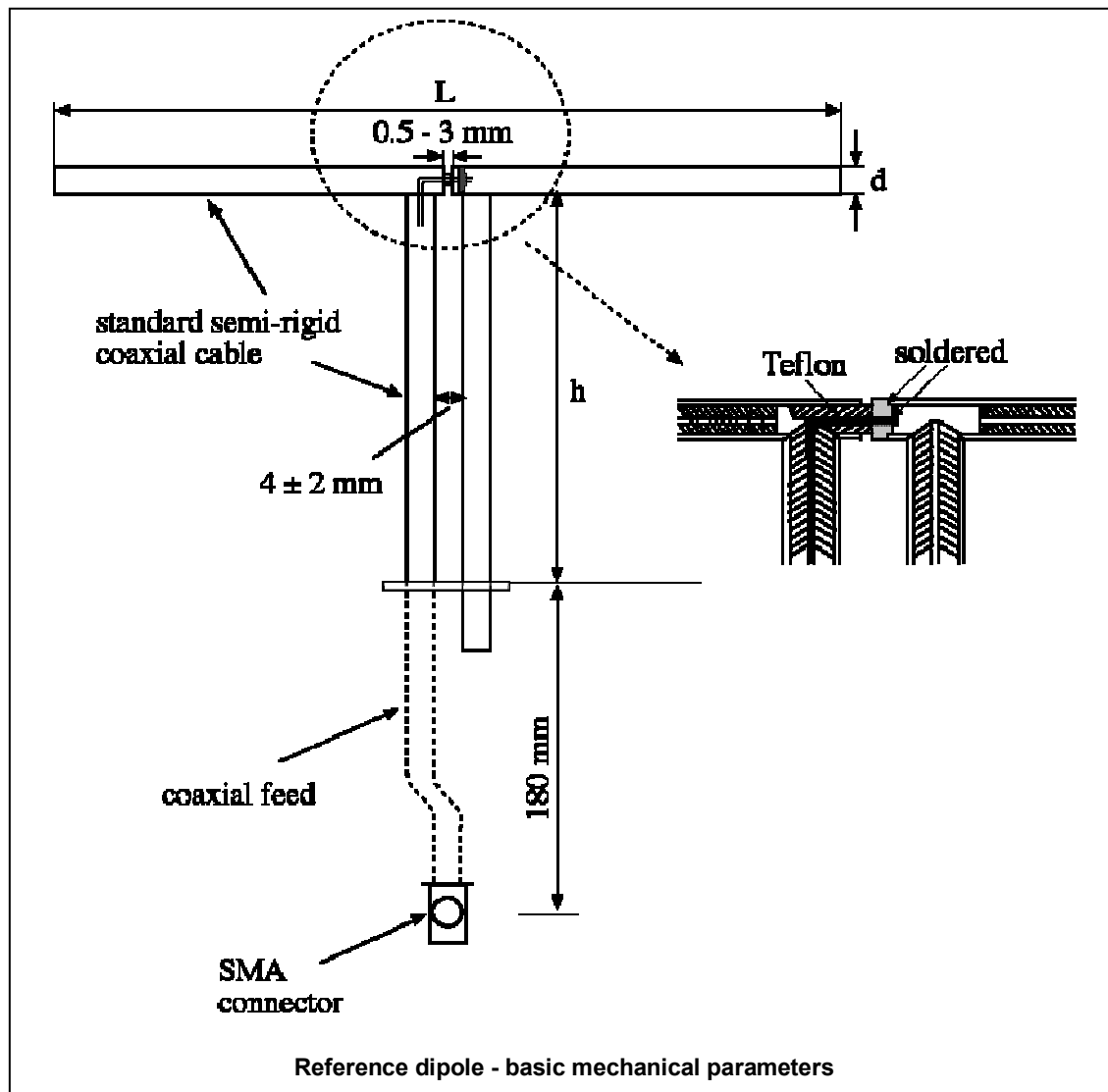

2. Validation Dipole VSWR Data

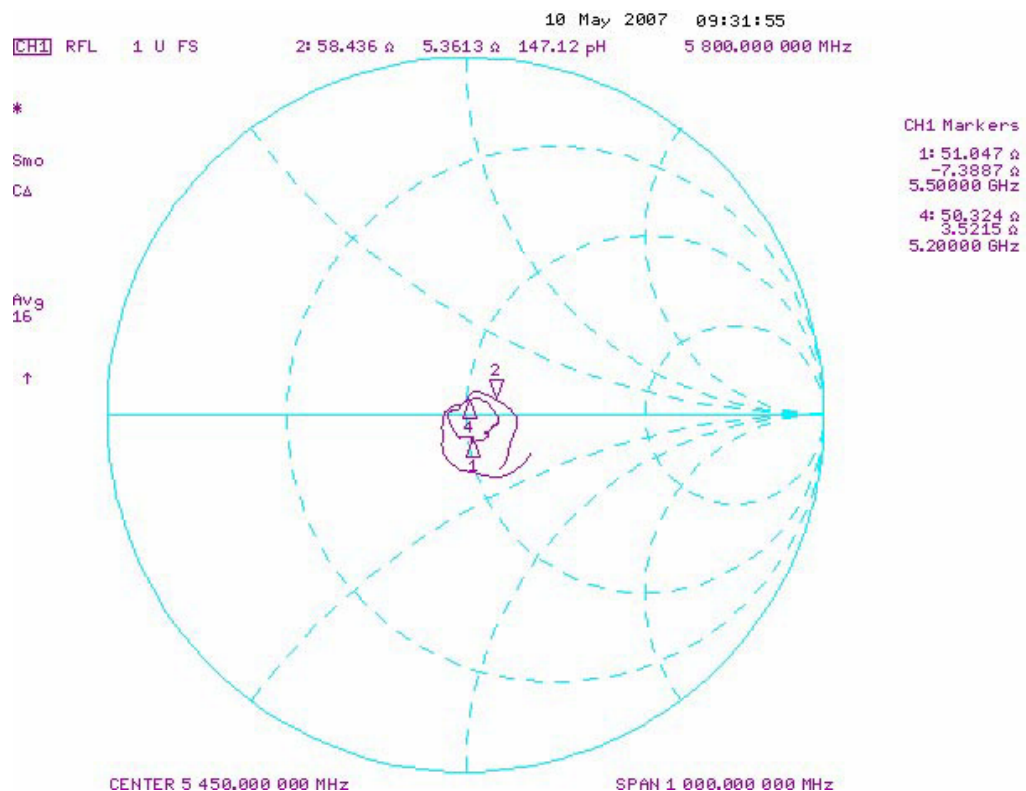
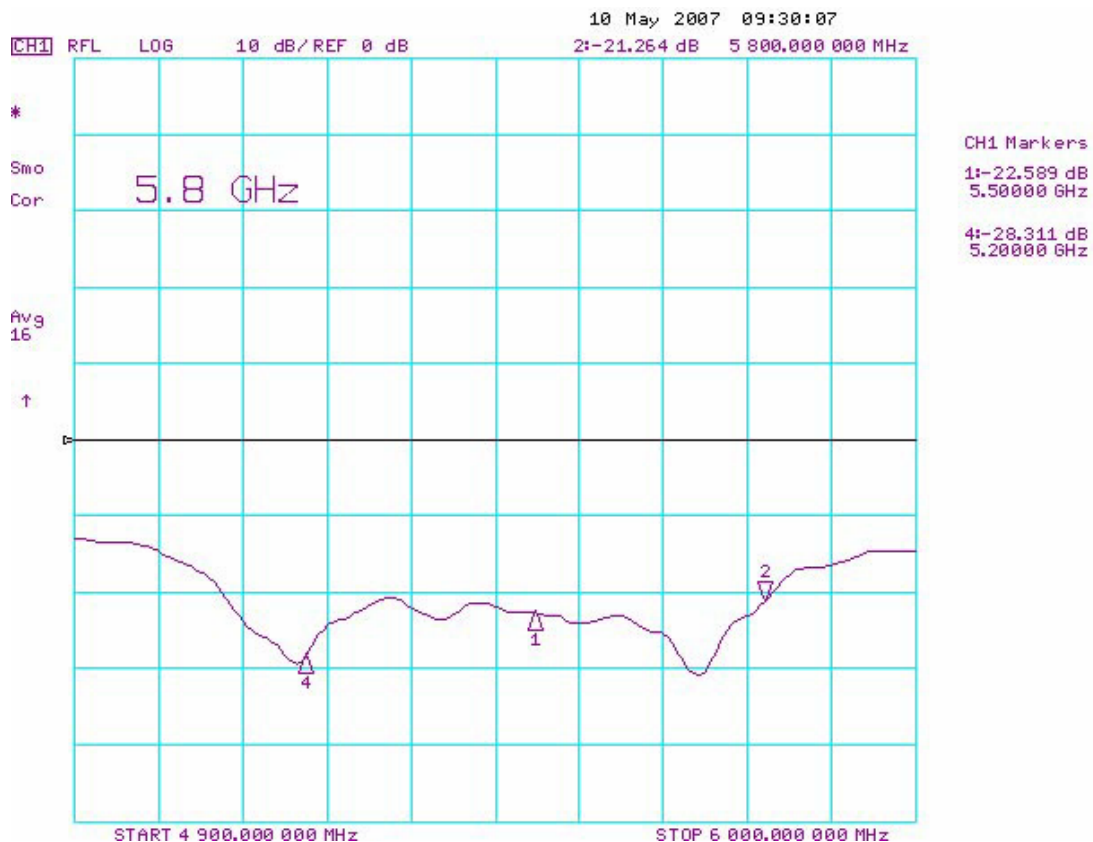

3. Validation Dipole Dimensions

Frequency (MHz)	L (mm)	H (mm)	D (mm)
300	396.0	250.0	6.0
450	270.0	167.0	6.0
835	161.0	89.8	3.6
900	149.0	83.3	3.6
1450	89.1	51.7	3.6
1800	72.0	41.7	3.6
1900	68.0	39.5	3.6
2000	64.5	37.5	3.6
2450	51.5	30.4	3.6
3000	41.5	25.0	3.6
5200 - 5800	20.6	40.65	3.6

4. Validation Phantom

The validation phantom is the SAM (Specific Anthropomorphic Mannequin) phantom manufactured by Schmid & Partner Engineering AG. The SAM phantom is a Fiberglass shell integrated in a wooden table. The shape of the shell corresponds to the phantom defined by SCC34-SC2. It enables the dosimetric evaluation of left and right hand phone usage as well as body mounted usage at the flat phantom region. A cover prevents evaporation of the liquid. Reference markings on the phantom allow the complete setup of all predefined phantom positions and measurement grids by manually teaching three points in the robot.

Shell Thickness: 2.0 ± 0.1 mm
Filling Volume: Approx. 25 liters
Dimensions: 50 cm (W) x 100 cm (L)

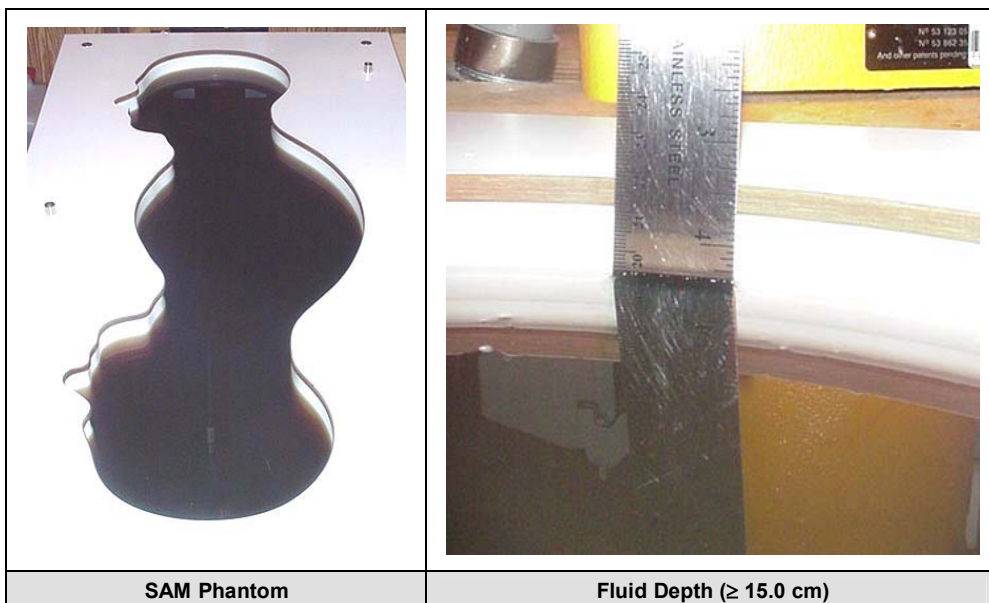

	Date of Evaluation:	May 10, 2007	Document Serial No.:	SV5800M-051007-R1.2		
	Evaluation Type:	System Validation	Validation Dipole:	5800 MHz	Fluid Type:	Body

5. 5800 MHz System Validation Setup



	Date of Evaluation:	May 10, 2007	Document Serial No.:	SV5800M-051007-R1.2		
	Evaluation Type:	System Validation	Validation Dipole:	5800 MHz	Fluid Type:	Body

6. 5800 MHz Validation Dipole Setup



7. SAR Measurement

Measurements were made using a dosimetric E-field probe EX3DV4 (S/N: 3600, Conversion Factor 4.14). The SAR measurement was performed with the E-field probe in mechanical detection mode only. The setup and determination of the forward power into the dipole was performed using the procedures described below.

First the power meter PM1 (including attenuator Att1) is connected to the cable to measure the forward power at the location of the dipole connector (X). The signal generator is adjusted for the desired forward power at the dipole connector (taking into account the attenuation of Att1) as read by power meter PM2. After connecting the cable to the dipole, the signal generator is readjusted for the same reading at power meter PM2. If the signal generator does not allow adjustment in 0.01dB steps, the remaining difference at PM2 must be taken into consideration. PM3 records the reflected power from the dipole to ensure that the value is not changed from the previous value. The reflected power should be 20dB below the forward power.

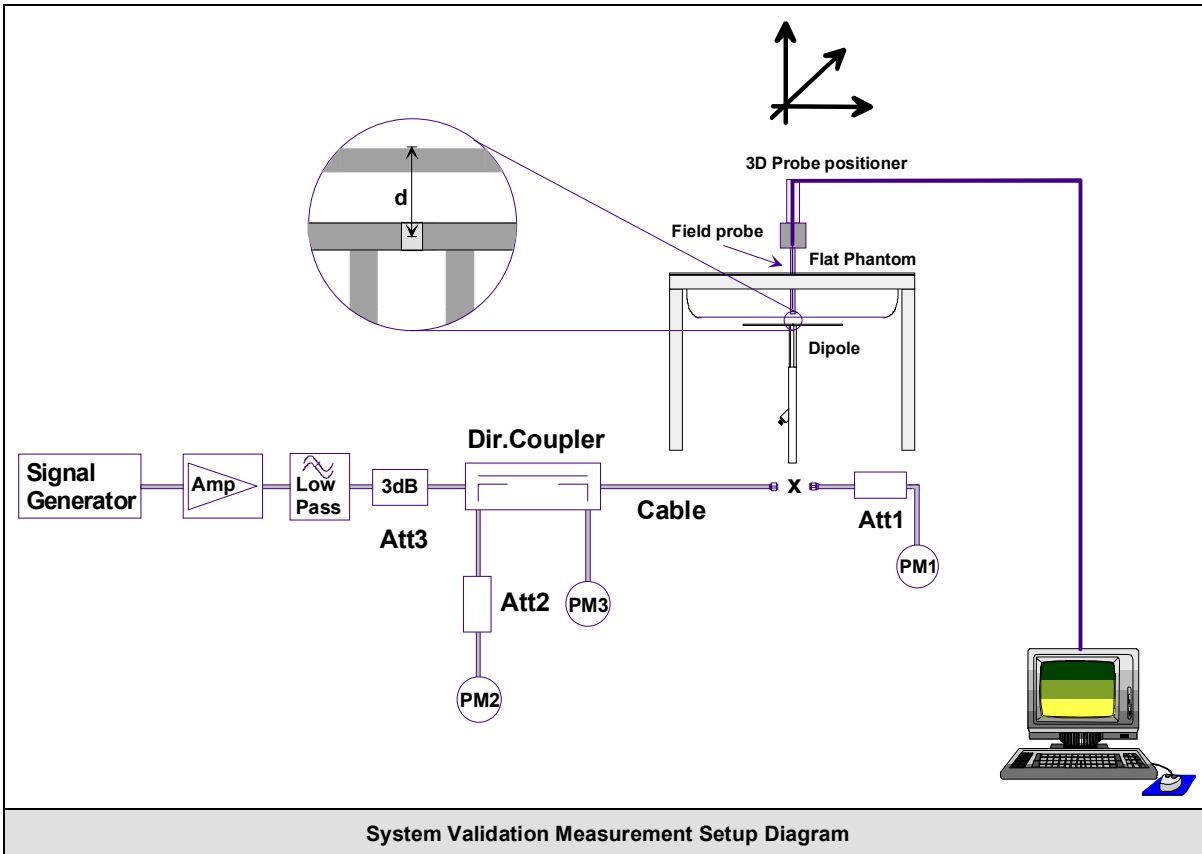

8. Measurement Conditions

The SAM phantom was filled with 5800 MHz Body tissue simulant.

Relative Permittivity: 44.7 (-7.2% deviation from target)
 Conductivity: 6.22 mho/m (+3.7% deviation from target)
 Fluid Temperature: 23.6 °C (Start of Test) / 23.2 °C (End of Test)
 Fluid Depth: ≥ 15.0 cm

Environmental Conditions:

Ambient Temperature: 23.1°C
 Humidity: 31%
 Barometric Pressure: 101.1 kPa

The 5800 MHz Body tissue simulant consisted of the following ingredients:

Ingredient	Percentage by weight	
Water	64 - 78%	
Mineral Oil	11 - 18%	
Emulsifiers	9 - 15%	
Additives and Salt	2 - 3%	
IEEE Target Dielectric Parameters:	$\epsilon_r = 48.2$ (+/-10%)	$\sigma = 6.00$ S/m (+/-5%)

9. System Validation SAR Results

SAR @ 0.25W Input averaged over 1g (W/kg)				SAR @ 1W Input averaged over 1g (W/kg)			
SPEAG Target		Measured	Deviation	SPEAG Target		Measured	Deviation
18.5	+/- 10%	19.1	+3.3%	74.1	+/- 10%	76.4	+3.1%
SAR @ 0.25W Input averaged over 10g (W/kg)				SAR @ 1W Input averaged over 10g (W/kg)			
SPEAG Target		Measured	Deviation	SPEAG Target		Measured	Deviation
5.13	+/- 10%	5.36	+4.5%	20.52	+/- 10%	21.44	+4.5%
Extrapolated Peak SAR		SPEAG Target	81.2	+/- 15%	Measured	87.3	+7.5%

Reference SAR values

The reference SAR values were calculated using finite-difference time-domain FDTD method (feed-point impedance set to 50Ω) and the mechanical dimensions of the D5GHzV2 dipole (manufactured by SPEAG).

f (GHz)	Head Tissue			Body Tissue		
	SAR_{1g}	SAR_{10g}	SAR_{peak}	SAR_{1g}	SAR_{10g}	SAR_{peak}
5.0	72.9	20.7	285.6	68.1	19.2	260.3
5.1	74.6	21.1	297.5	78.8	19.6	272.3
5.2	76.5	21.6	310.3	71.8	20.1	284.7
5.5	83.3	23.4	349.4	79.1	22.0	326.3
5.8	78.0	21.9	340.9	74.1	20.5	324.7

Table 27.2: Numerical reference SAR values for D5GHzV2 dipole and flat phantom.

	Date of Evaluation:	May 10, 2007	Document Serial No.:	SV5800M-051007-R1.2
	Evaluation Type:	System Validation	Validation Dipole:	5800 MHz
			Fluid Type:	Body

System Validation - 5800 MHz Dipole - May 10, 2007

DUT: Dipole 5GHz; Type: D5GHzV2; Serial: 1031; Asset: 00126

Ambient Temp: 23.1°C; Fluid Temp: 23.6°C; Barometric Pressure: 101.1 kPa; Humidity: 31%

Communication System: CW

Forward Conducted Power: 250 mW

Frequency: 5800 MHz; Duty Cycle: 1:1

Medium: M5200-5800 Medium parameters used: $f = 5800$ MHz; $\sigma = 6.22$ mho/m; $\epsilon_r = 44.7$; $\rho = 1000$ kg/m³

- Probe: EX3DV4 - SN3600; ConvF(4.14, 4.14, 4.14); Calibrated: 24/01/2007
- Sensor-Surface: 2mm (Mechanical Surface Detection)
- Electronics: DAE4 Sn353; Calibrated: 21/06/2006
- Phantom: SAM 4.0; Type: Fibreglas; Serial: 1033
- Measurement SW: DASY4, V4.7 Build 44; Postprocessing SW: SEMCAD, V1.8 Build 171

5800 MHz System Validation/Area Scan (9x13x1):

Measurement grid: dx=5mm, dy=5mm

Maximum value of SAR (measured) = 40.6 mW/g

5800 MHz System Validation/Zoom Scan (7x7x9)/Cube 0:

Measurement grid: dx=4mm, dy=4mm, dz=2.5mm

Reference Value = 83.1 V/m; Power Drift = 0.174 dB

Peak SAR (extrapolated) = 87.3 W/kg

SAR(1 g) = 19.1 mW/g; SAR(10 g) = 5.36 mW/g

Maximum value of SAR (measured) = 40.2 mW/g

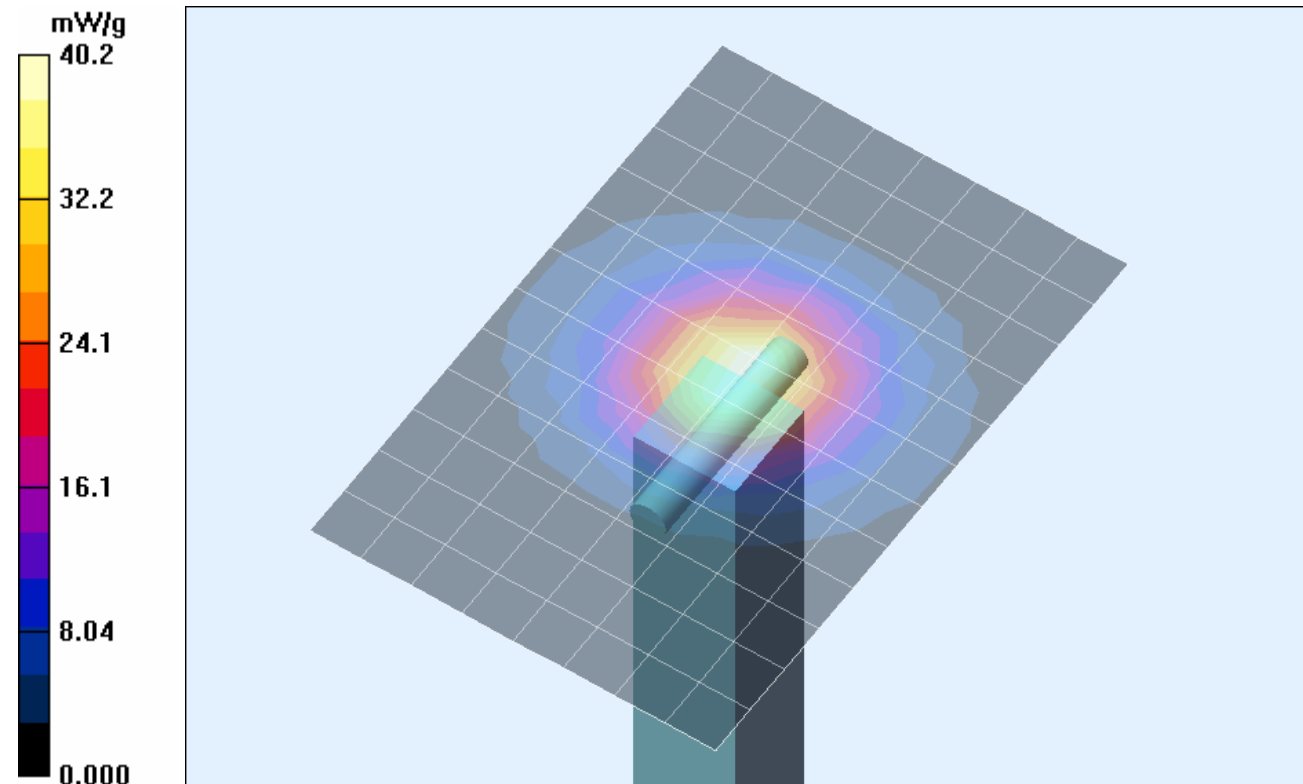

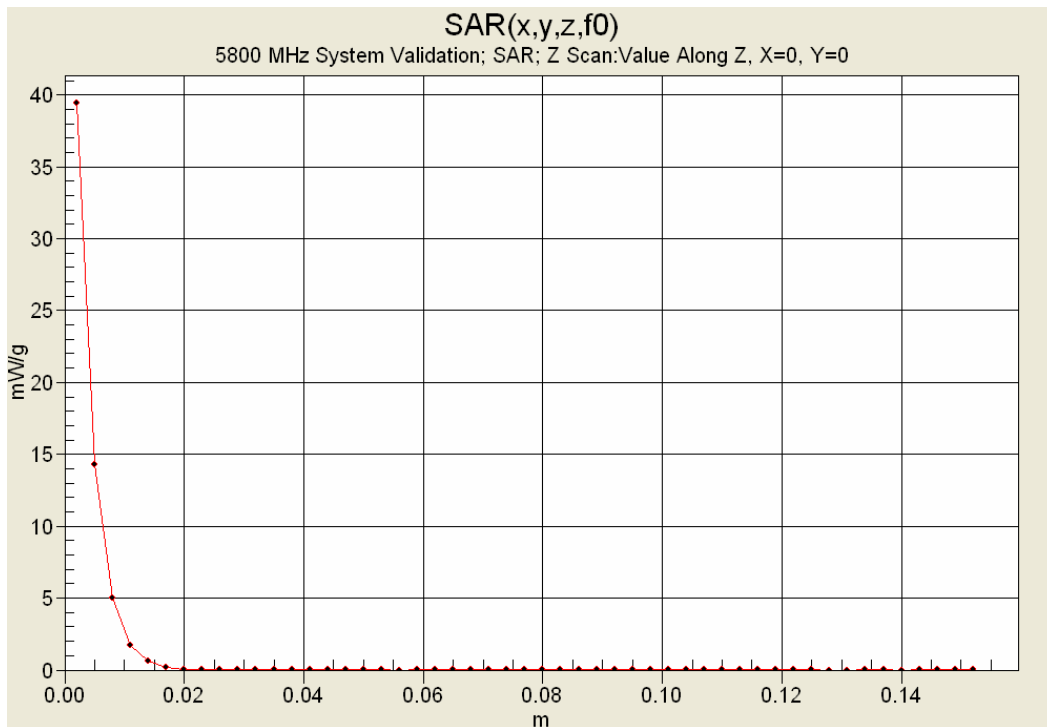

10. Measured Fluid Dielectric Parameters

System Validation - 5800 MHz (Body)

Celltech Labs Inc.

Test Result for UIM Dielectric Parameter

Mon 10/May/2007

Frequency (GHz)

FCC_eH FCC Bulletin 65 Supplement C (June 2001) Limits for Head Epsilon

FCC_sH FCC Bulletin 65 Supplement C (June 2001) Limits for Head Sigma

FCC_eB FCC Limits for Body Epsilon

FCC_sB FCC Limits for Body Sigma

Test_e Epsilon of UIM

Test_s Sigma of UIM

Freq	FCC_eB	FCC_sB	Test_e	Test_s
5.7000	48.34	5.88	44.57	6.11
5.7100	48.32	5.89	44.13	6.03
5.7200	48.31	5.91	43.79	6.06
5.7300	48.30	5.92	43.57	6.11
5.7400	48.28	5.93	43.53	6.26
5.7500	48.27	5.94	43.52	6.33
5.7600	48.25	5.95	43.73	6.49
5.7700	48.24	5.96	44.19	6.52
5.7800	48.23	5.98	44.57	6.48
5.7900	48.21	5.99	44.66	6.37
5.8000	48.20	6.00	44.67	6.22
5.8100	48.19	6.01	44.53	6.14
5.8200	48.17	6.02	44.13	6.07
5.8300	48.16	6.04	43.75	6.09
5.8400	48.15	6.05	43.46	6.20
5.8500	48.13	6.06	43.36	6.33
5.8600	48.12	6.07	43.32	6.51
5.8700	48.10	6.08	43.57	6.64
5.8800	48.09	6.09	43.99	6.65
5.8900	48.08	6.11	44.33	6.63
5.9000	48.06	6.12	44.43	6.55

	Date of Evaluation:	May 10, 2007	Document Serial No.:		SV5800M-051007-R1.2	
	Evaluation Type:	System Validation	Validation Dipole:	5800 MHz	Fluid Type:	Body

11. Measurement Uncertainties

UNCERTAINTY BUDGET FOR SYSTEM VALIDATION						
Error Description	Uncertainty Value $\pm\%$	Probability Distribution	Divisor	ci 1g	Uncertainty Value $\pm\%$ (1g)	V_i or V_{eff}
Measurement System						
Probe calibration (5800 MHz)	6.55	Normal	1	1	6.55	∞
Axial isotropy of the probe	4.7	Rectangular	1.732050808	1	2.7	∞
Spherical isotropy of the probe	9.6	Rectangular	1.732050808	1	5.5	∞
Spatial resolution	0	Rectangular	1.732050808	1	0.0	∞
Boundary effects	0.1	Rectangular	1.732050808	1	0.1	∞
Probe linearity	4.7	Rectangular	1.732050808	1	2.7	∞
Detection limit	1	Rectangular	1.732050808	1	0.6	∞
Readout electronics	0.3	Normal	1	1	0.3	∞
Response time	0	Rectangular	1.732050808	1	0.0	∞
Integration time	0	Rectangular	1.732050808	1	0.0	∞
RF ambient conditions	3	Rectangular	1.732050808	1	1.7	∞
Mech. constraints of robot	0.8	Rectangular	1.732050808	1	0.5	∞
Probe positioning	5.7	Rectangular	1.732050808	1	3.3	∞
Extrapolation & integration	4	Rectangular	1.732050808	1	2.3	∞
Dipole						
Dipole positioning	2	Rectangular	1.732050808	1	1.2	∞
Power & Power Drift	4.7	Rectangular	1.732050808	1	2.7	∞
Phantom and Setup						
Phantom uncertainty	4	Rectangular	1.732050808	1	2.3	∞
Liquid conductivity (target)	5	Rectangular	1.732050808	0.64	1.8	∞
Liquid conductivity (measured)	3.7	Normal	1	0.64	2.4	∞
Liquid permittivity (target)	10	Rectangular	1.732050808	0.6	3.5	∞
Liquid permittivity (measured)	7.2	Normal	1	0.6	4.3	∞
Combined Standard Uncertainty					12.72	
Expanded Uncertainty (k=2)					25.45	
Measurement Uncertainty Table in accordance with IEEE Standard 1528-2003 and IEC Standard 62209-1:2005						

12. Test Equipment List

TEST EQUIPMENT	ASSET NO.	SERIAL NO.	DATE OF CAL.	CAL. DUE DATE
SPEAG DASY4 Measurement Server	00158	1078	N/A	N/A
SPEAG Robot	00046	599396-01	N/A	N/A
SPEAG DAE4	00019	353	21Jun06	21Jun07
SPEAG EX3DV4 E-Field Probe	00213	3600	24Jan07	24Jan08
SPEAG 5GHz Validation Dipole	00126	1031	10May07	10May08
SPEAG SAM Phantom V4.0C	00154	1033	N/A	N/A
ALS-PR-DIEL Dielectric Probe Kit	00160	260-00953	N/A	N/A
Gigatronics 8652A Power Meter	00007	1835272	26Mar07	26Mar08
Gigatronics 80701A Power Sensor	00014	1833699	22Jan07	22Jan08
Gigatronics 80701A Power Sensor	00109	1834366	26Mar07	26Mar08
HP 8753ET Network Analyzer	00134	US39170292	20Apr07	20Apr08
Nextec NB00383 Microwave Amplifier	00151	0535	NCR	NCR
Rohde & Schwarz SMR20 Signal Generator	00006	100104	NCR	NCR