

FCC Verification Test Report

Report No.: FCC_RF_SL19080201-IDS-007 Rev 3.0

Test Model: IBIS-KU-ETH100

Series Model: N/A

FCC ID UFW-IBIS-KU-ETH

Received Date: 09/18/2019

Test Date: 09/18/2019-09/20/2019

Issued Date: 10/14/2019

Applicant: IDS GeoRadar s.r.l.

Address: Via A. Righi, 56121 PISA (PI)- Italy

Issued By: Bureau Veritas Consumer Products Services, Inc.

Lab Address: 775 Montague Expressway, Milpitas, CA 95035

Test Location (1): 775 Montague Expressway, Milpitas, CA 95035

**FCC Registration /
Designation Number:** 540430
**IC Registration /
Designation Number:** 4842D



This report is for your exclusive use. Any copying or replication of this report to or for any other person or entity, or use of our name or trademark, is permitted only with our prior written permission. This report sets forth our findings solely with respect to the test samples identified herein. The results set forth in this report are not indicative or representative of the quality or characteristics of the lot from which a test sample was taken or any similar or identical product unless specifically and expressly noted. Our report includes all of the tests requested by you and the results thereof based upon the information that you provided to us. You have 60 days from date of issuance of this report to notify us of any material error or omission caused by our negligence, provided, however, that such notice shall be in writing and shall specifically address the issue you wish to raise. A failure to raise such issue within the prescribed time shall constitute your unqualified acceptance of the completeness of this report, the tests conducted and the correctness of the report contents. Unless specific mention, the uncertainty of measurement has been explicitly taken into account to declare the compliance or non-compliance to the specification. The report must not be used by the client to claim product certification, approval, or endorsement by A2LA or any government agencies.

Table of Contents

Release Control Record	3
1 Certificate of Conformity	4
2 Summary of Test Results	5
2.1 Test Instruments	6
2.2 Modification Record	7
3 General Information	8
3.1 General Description of EUT	8
3.2 Description of Support Units	9
3.2.1 Configuration of System under Test	10
3.3 General Description of Applied Standards	10
4 Test Procedure and Results	11
4.1 RF Output Power and E.I.R.P	11
4.1.1 Limits of RF Output Power	11
4.1.2 Test Procedures	11
4.1.3 Deviation from Test Standard	11
4.1.4 Test Setup	11
4.1.5 Test Results	12
4.2 99% Bandwidth	13
4.2.1 Limits of RF 99% bandwidth	13
4.2.2 Test Procedures	13
4.2.3 Deviation from Test Standard	13
4.2.4 Test Setup	13
4.2.5 Test Results	14
4.3 Frequency stability	17
4.3.1 Limits of RF 99% bandwidth	17
4.3.2 Test Procedures	17
4.3.3 Deviation from Test Standard	17
4.3.4 Test Setup	17
4.3.5 Test Results	18
4.4 Radiated spurious Emissions in the spurious domain	19
4.4.1 Limits of Transmitter Spurious Emissions	19
4.4.2 Test Procedure	19
4.4.3 Deviation from Test Standard	19
4.4.4 Test Setup	19
4.4.5 Test Results	20
Testing is done at 3m distance.Receiver Spurious Emissions	21
Appendix - Information on the Testing Laboratories	22

Release Control Record

Issue No.	Description	Date Issued
FCC_RF_SL19080201-IDS-007	Original	09/30/2019
FCC_RF_SL19080201-IDS-007 Rev 1.0	Updated per client	10/14/2019
FCC_RF_SL19080201-IDS-007 Rev 2.0	Updated per reviewer	10/23/2019
FCC_RF_SL19080201-IDS-007 Rev 3.0	Updated antenna information	10/30/2019

1 Certificate of Conformity

Product: IBIS Sensor
Brand: IDS
Test Model: IBIS-KU-ETH100
Series Model: N/A
Sample Status: Engineering sample
Applicant: IDS GeoRadar s.r.l.
Test Date: 09/18/2019 – 09/20/2019

The above equipment has been tested by **Bureau Veritas Consumer Products Services, Inc., Milpitas Branch**, and found compliance with the requirement of the above standards. The test record, data evaluation & Equipment Under Test (EUT) configurations represented herein are true and accurate accounts of the measurements of the sample's EMC characteristics under the conditions specified in this report.

Prepared by : *Gary Chou* , **Date:** 09/30/2019
 Gary Chou Test Engineer

Approved by : *Chen Ge* , **Date:** 09/30/2019
 Chen Ge Engineering Reviewer

2 Summary of Test Results

The EUT has been tested according to the following specifications:

Clause	Test Parameter	Results
2.1046	RF Output Power	Pass
2.1055	Frequency Stability	N/A*
2.1049	Occupied Bandwidth	Pass
2.1053	Spurious Emission	Pass

The report is for a Class II permissive change to reduce the operating frequency from 17.1-17.3 GHz down to 17.1-17.2 GHz, the original data refers to report FCC-17366 with FCC ID UFW-IBIS-KU-ETH. Frequency band capability of the device is decreased and there are no radio parameter changes to the radiated and conducted output power of the device, and no degradation to EMC parameters due to the decreased frequency. RF output power verification results are for verification purposes only, refer to report no. FCC-17366 for output power data.

*Refer to report no. FCC-17366 for test results.

2.1 Test Instruments

For spurious emissions test:

Description & Manufacturer	Model No.	Serial No.	Calibrated Date	Calibrated Until
Keysight Signal Generator	MXG N5182A	MY47071065	06/28/2019	06/28/2020
50GHz Spectrum Analyzer	N9030B (PXA)	MY57140374	07/22/2019	07/22/2020
Preamplifier RF-Lambda	RAMP00M50GA	17032300047	08/19/2019	08/19/2020
RF Preamplifier	LPA-6-30	11170602	05/06/2019	05/06/2020
Hybrid Antenna SUNAR	JB6	A111717	03/09/2019	03/09/2020
DRG Horn Antenna ETS LINDGREN	3117	214309	11/22/2018	11/22/2019
Tuned Dipole Antenna 30 - 1000 MHz (4pcs set)	AD-100	40133	01/23/2018	01/23/2020

For other test items:

Description & Manufacturer	Model No.	Serial No.	Calibrated Date	Calibrated Until
50GHz Spectrum Analyzer	N9030B (PXA)	MY57140584	07/22/2019	07/22/2020
Test Equity Environment Chamber	1007H	61201	11/08/2018	11/08/2019
ETS-Lingren USB RF Power Sensor	7002-006	10SL0190	02/18/2018	02/18/2020

Where relevant, the following measurement uncertainty levels have been estimated for tests performed on the EUT:

This uncertainty represents an expanded uncertainty expressed at approximately the 95% confidence level using a coverage factor of $k=2$.

Measurement	Frequency	Expanded Uncertainty ($k=2$) (\pm)
Conducted Emissions at mains ports	150kHz ~ 30MHz	3.51dB
Radiated Emissions up to 1 GHz	30MHz ~ 1GHz	3.73dB
Radiated Emissions above 1 GHz	1GHz ~ 6GHz	4.64dB
	6GHz ~ 18GHz	4.82dB
	18GHz ~ 40GHz	4.91dB

2.2 Modification Record

There were no modifications required for compliance.

3 General Information

3.1 General Description of EUT

Product	IBIS Sensor
Brand	IDS
Test Model	IBIS-KU-ETH100
Identification No. of EUT	N/A
Series Model	N/A
Status of EUT	Engineering sample
Nominal Voltage	9-36VDC
Modulation Type	FMCW
Operating Frequency	17.1 GHz ~ 17.2GHz
Antenna Type	External
Antenna Gain (dBi)	Low Gain antenna: 13.3dBi High Gain antenna: 22dBi
Antenna Connector	Waveguide
Version of Hardware	N/A
Version of Software or Firmware	N/A

Note:

1. The above EUT information is declared by manufacturer and for more detailed features description, please refers to the manufacturer's specifications or user's manual.

3.2 Description of Support Units

The EUT has been tested as an independent unit together with other necessary accessories or support units. The following support units or accessories were used to form a representative test configuration during the tests.

ID	Product	Brand	Model No.	Serial No.	Remarks
A.	Laptop	Dell	Latitude E6510	N/A	Provided by Customer
B.					
C.					
D.					
E.					
F.					

Note:

1. All power cords of the above support units are non-shielded (1.8m).

ID	Descriptions	Qty.	Length (m)	Shielding (Yes/No)	Cores (Qty.)	Remarks
1.	USB cable	1	0.8	N	0	Provided by Customer
2.						
3.						
4.						
5.						
6.						

Note: The core(s) is(are) originally attached to the cable(s).

3.2.1 Configuration of System under Test

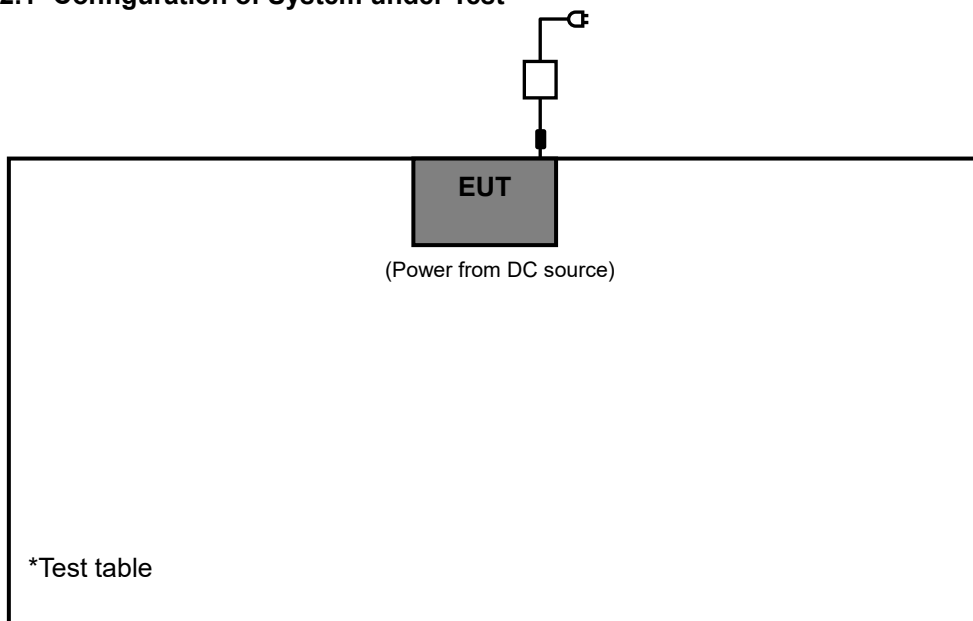

3.3 General Description of Applied Standards

The EUT is a RF Product. According to the specifications of the manufacturer, it must comply with the requirements of the following standard:

All test items have been performed and recorded as per the above standard.

4 Test Procedure and Results

4.1 RF Output Power and E.I.R.P

4.1.1 Limits of RF Output Power

Condition	Frequency Band	Limit
Normal	17.1 ~ 17.2 GHz	N/A

4.1.2 Test Procedures

Refer to ANSI C63.10 2013 and TIA-603-E-2016

Measurement Method	
<input checked="" type="checkbox"/> Conducted measurement	<input type="checkbox"/> Radiated measurement

4.1.3 Deviation from Test Standard

No deviation.

4.1.4 Test Setup

The measurements for RF output power was performed at normal environmental conditions. TeraTerm has been activated to set the EUT on specific channel and power level.

4.1.5 Test Results

Original test data:

Test mode	Frequency Range (GHz)	Output Power port 1 (dBm)	Output Power port 2 (dBm)	Antenna Gain (dBi)	Result
Low Gain	17.10	19.9	20.4	13.3	Pass
	17.20	20.5	19.6	13.3	Pass
	17.30	19.1	19.7	13.3	Pass
High Gain	17.10	13.6	13.8	22	Pass
	17.20	13.9	12.9	22	Pass
	17.30	12.3	12.9	22	Pass

Verification test data:

Test mode	Frequency Range (GHz)	Output Power port 1 (dBm)	Output Power port 2 (dBm)	Antenna Gain (dBi)	Result
Low Gain	17.10	19.31	19.92	13.3	Pass
	17.15	19.78	19.12	13.3	Pass
	17.20	19.35	19.53	13.3	Pass
High Gain	17.10	13.13	13.41	22	Pass
	17.15	13.45	12.11	22	Pass
	17.20	11.87	12.23	22	Pass

4.2 99% Bandwidth

4.2.1 Limits of RF 99% bandwidth

Condition	Frequency Band	Limit
Normal	17.1 ~ 17.2 GHz	N/A

4.2.2 Test Procedures

Refer to ANSI C63.10 2013 and TIA-603-E-2016

Measurement Method	
<input checked="" type="checkbox"/> <input type="checkbox"/> Conducted measurement	<input type="checkbox"/> <input type="checkbox"/> Radiated measurement

4.2.3 Deviation from Test Standard

No deviation.

4.2.4 Test Setup

The measurements for RF output power was performed at normal environmental conditions.

4.2.5 Test Results

Type	Antenna	Port	Result (MHz)
99% OBW	Low Gain	1	99.994
	High Gain	1	99.928
	Low Gain	2	99.708
	High Gain	2	99.459

99% Bandwidth Test Plots

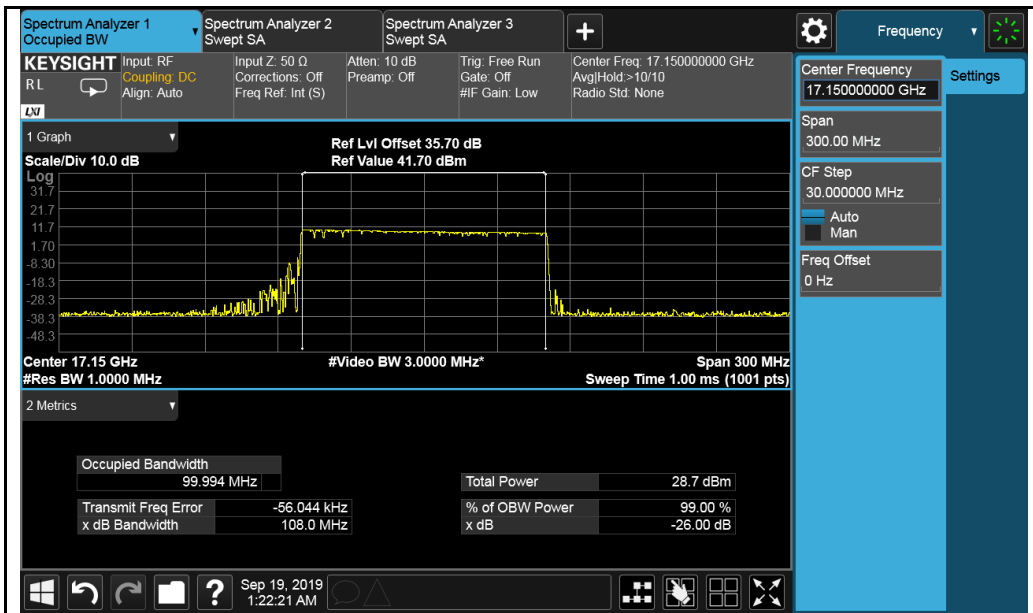

Low Gain antenna, port 1

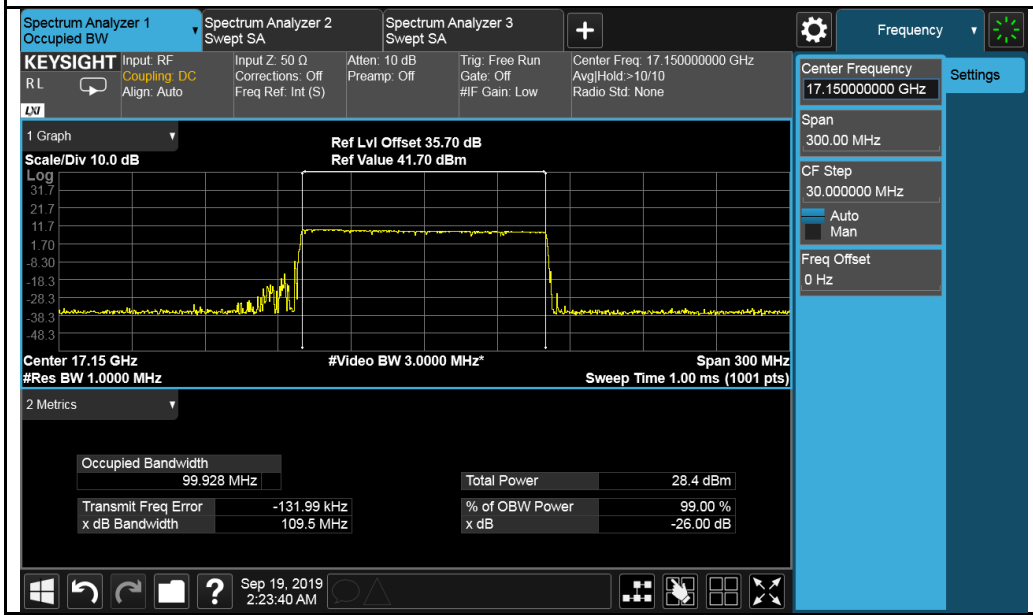

High Gain antenna, port 1

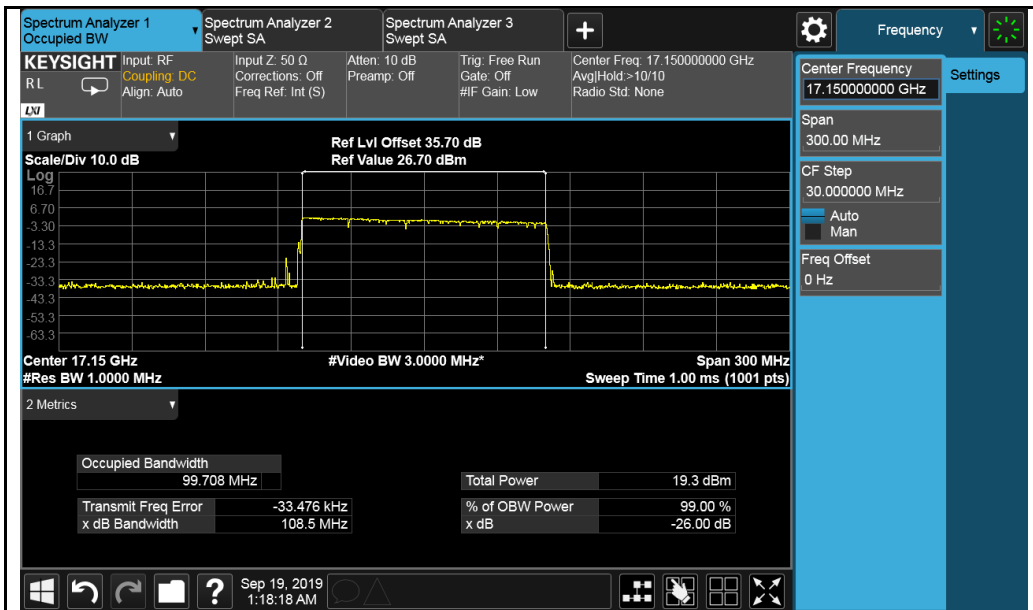

Low Gain antenna, port 2

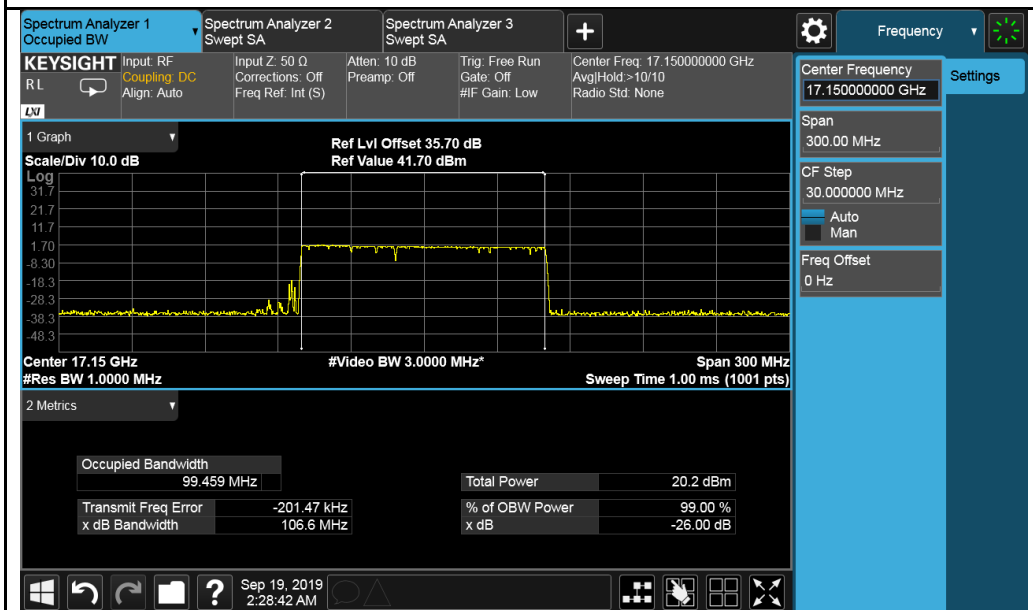

High Gain antenna, port 2

4.3 Frequency stability

4.3.1 Limits of RF 99% bandwidth

Condition	Frequency Band	Limit
Normal	17.1 ~ 17.2 GHz	N/A

4.3.2 Test Procedures

Refer to ANSI C63.10 2013 and TIA-603-E-2016

Measurement Method	
<input checked="" type="checkbox"/> <input type="checkbox"/> Conducted measurement	<input type="checkbox"/> <input type="checkbox"/> Radiated measurement

4.3.3 Deviation from Test Standard

No deviation.

4.3.4 Test Setup

The measurements was performed at normal environmental conditions.

4.3.5 Test Results

Refer to test report no. FCC-17366 for test results.

4.4 Radiated spurious Emissions in the spurious domain

4.4.1 Limits of Transmitter Spurious Emissions

On any frequency removed from the center of the authorized bandwidth by more than 250 percent of the authorized bandwidth: At least $43 + 10 \log (P)$ dB.

4.4.2 Test Procedure

Refer to ANSI C63.10 2013 and TIA-603-E-2016

Measurement Method	
<input type="checkbox"/> Conducted measurement	<input checked="" type="checkbox"/> Radiated measurement

4.4.3 Deviation from Test Standard

No deviation.

4.4.4 Test Setup

1. For the actual test configuration, please refer to the related Item in this test report (Photographs of the Test Configuration).
2. The equipment was configured to operate under its worst case situation with respect to output power.
3. The test setup has been constructed as the normal use condition. TeraTerm has been activated to set the EUT on specific status.

4.4.5 Test Results

Test specification:	Radiated Spurious Emissions		
Mains Power:	120 VAC, 60 Hz	Result:	<input checked="" type="checkbox"/> Pass <input type="checkbox"/> Fail
Tested by:	Gary Chou		
Test Date:	09/19/2019		
Remarks:	Middle channel, 30MHz – 1GHz		

Indicated			Test Antenna		Substituted						
Frequency (MHz)	Raw (dBm)	Degree	Height (cm)	Polarity	Frequency (MHz)	Level (dBm)	Ant Gain (dBi)	Cable Loss (dB)	Absolute Level (dBm)	Limit (dBm)	Margin (dB)
857.5	-48.22	122	144	V	857.5	-43.32	0	0.88	-44.2	-13	-31.2
857.5	-46.57	189	198	H	857.5	-41.69	0	0.88	-42.57	-13	-29.57
349.99	-47.18	209	176	V	349.99	-42.3	0	0.53	-42.83	-13	-29.83
349.99	-49.19	301	201	H	349.99	-44.31	0	0.53	-44.84	-13	-31.84
599.8	-52.68	298	165	V	599.8	-47.8	0	0.62	-48.42	-13	-35.42
599.8	-48.86	100	192	H	599.8	-43.98	0	0.62	-44.6	-13	-31.6

Testing is done at 3m distance.



Test specification:	Radiated Spurious Emissions		
Mains Power:	120 VAC,60 Hz		Result: <input checked="" type="checkbox"/> Pass <input type="checkbox"/> Fail
Tested by:	Gary Chou		
Test Date:	09/20/2019		
Remarks:	Middle channel, 1GHz – 18GHz		

Indicated			Test Antenna		Substituted						
Frequency (MHz)	Raw (dBm)	Degree	Height (cm)	Polarity	Frequency (MHz)	Level (dBm)	Ant Gain (dBi)	Cable Loss (dB)	Absolute Level (dBm)	Limit (dBm)	Margin (dB)
3678.5	-51.02	209	145	V	3678.5	-44.81	9.5	2.42	-37.73	-13	-24.73
3678.5	-54.32	199	198	H	3678.5	-47.84	9.5	2.42	-40.76	-13	-27.76
11123.45	-53.65	209	201	V	11123.45	-53.11	10.96	4.62	-46.77	-13	-33.77
11123.45	-53.04	332	189	H	11123.45	-52.02	10.96	4.62	-45.68	-13	-32.68
11435	-51.88	187	165	V	11435	-45.63	11.98	4.42	-38.07	-13	-25.07
11435	-54.84	27	188	H	11435	-48.36	11.98	4.42	-40.8	-13	-27.8

Testing is done at 3m distance.Receiver Spurious Emissions

Appendix - Information on the Testing Laboratories

Bureau Veritas is a global leader in testing, inspection and certification (TIC) services. We help businesses improve safety, sustainability and productivity; and our clients include the majority of leading brands in retail, manufacturing and other industries. With a presence in every major country around the world, our quality assurance and compliance solutions are vital in helping our customers enhance product quality and concept-to-consumer journeys. We also assist with increasing speed to market, profitability and brand equity throughout the supply chain. Bureau Veritas is a leading wireless/IoT testing, inspection, audit and certification provider, with a global network of test laboratories to support the IoT industry in areas of connectivity, security, interoperability as well as quality, health & safety, and environmental/chemical requirements.

If you have any comments, please feel free to contact us at the following:

Milpitas EMC/RF/Safety/Telecom Lab

775 Montague Expressway, Milpitas, CA 95035

Tel: +1 408 526 1188

Sunnyvale OTA/Bluetooth Lab

1293 Anvilwood Avenue, Sunnyvale, CA 94089

Tel: +1 669 600 5293

Littleton EMC/RF/Safety/Environmental Lab

1 Distribution Center Cir #1, Littleton, MA 01460

Tel: +1 978 486 8880

Irvine OTA/PTCRB/Bluetooth/V2X Lab

15 Musick, Irvine, CA 92618

Tel: +1 949 716 6512

Email: sales.eaw@us.bureauveritas.com

Web Site: www.cpsusa-bureauveritas.com

The address and road map of all our labs can be found in our web site also.

--- END ---