

# Leica DD300 Connect - Cable Locator Leica DA300 Transmitter



User Manual  
Version 0.9  
English

- when it has to be **right**

**Leica**  
Geosystems

PART OF  
**HEXAGON**

# Introduction

## Purchase

Congratulations on the purchase of a Leica Detection product.



This manual contains important safety directions as well as instructions for setting up the product and operating it. Refer to **1 Safety Directions** for further information.

Read carefully through the User Manual before you switch on the product.



The content of this document is subject to change without prior notice. Ensure that the product is used in accordance with the latest version of this document.

Updated versions are available for download at the following Internet address:  
<https://myworld-portal.leica-geosystems.com/> > myDownloads

## Product identification

The model and serial number of your product are indicated on the type label. Always refer to this information when contacting your agency or Leica Geosystems authorised service centre.



## Trademarks

- *Bluetooth®* is a registered trademark of Bluetooth SIG, Inc.
- All other trademarks are the property of their respective owners.

## Validity of this manual

This manual applies to the Leica Detection DD series locators, DA series transmitters and Detection accessories. Differences between the models are marked and described.

## Available documentation

Name	Description/Format		
Leica DD300 Series Locators & Accessories Quick Guide	Provides an overview of the product together with technical data and safety directions. Intended as a quick reference field guide.	✓	✓
Leica DD300 Series Locators & Accessories User Manual	All instructions required in order to operate the product to a basic level are contained in the User Manual. Provides an overview of the product together with technical data and safety directions.		✓

### Refer to the following resources for all Leica DD300 documentation/software:

- <https://myworld-portal.leica-geosystems.com/>



<https://myworld-portal.leica-geosystems.com/> offers a wide range of services, information and training material.

With direct access to myWorld, you are able to access all relevant services whenever it is convenient for you.

The availability of services depends on the instrument model.

Service	Description
My Products	Register all products that you and your company own and explore your world of Leica Geosystems: View detailed information on your products and update your products with the latest software and keep up-to-date with the latest documentation.
My Service	View the current service status and full service history of your products in Leica Geosystems service centres. Access detailed information on the services performed and download your latest calibration certificates and service reports.
My Support	Create new support requests for your products that will be answered by your local Leica Geosystems support team. View your complete support history and view detailed information on all your support requests.
Knowledge	Enter key words and start searching in our knowledge base. You can find FAQs (Frequently asked questions) as well as Knowledge articles for Leica Geosystems products.
Downloads	Downloads of software, manuals, tools, training material and news for Leica Geosystems products. Download the latest documentation and software to keep yourself and your products up-to-date. You can access downloads of software, manuals, tools, and training material.
Online Learning	Welcome to the home of Leica Geosystems online learning! There are numerous online courses – available to all customers with products that have valid CCPs (Customer Care Packages).
My Trusted Services	Leica Geosystems Trusted Services offer you increased productivity while at the same time providing maximum security. New software services and state-of-the-art IT infrastructure offer a vast potential to optimise your workflow and increase your efficiency and productivity, both now and in the future.
My Security	Leica Geosystems Security delivers you total peace-of-mind in knowing that if your instrument is ever stolen, a locking mechanism is available to ensure that the instrument is disabled and can no longer be used.

# Table of Contents

<b>1</b>	<b>Safety Directions</b>	<b>6</b>
1.1	General	6
1.2	Definition of Use	6
1.3	Limits of Use	7
1.4	Responsibilities	7
1.5	Hazards of Use	8
	1.5.1 General	8
	1.5.2 Using the Product with a Signal Transmitter	11
	1.5.3 Connecting the Cable Set of the Transmitter to a Live Utility	12
1.6	Electromagnetic Compatibility (EMC)	13
1.7	Disposal - ACPEIP Forms	14
<b>2</b>	<b>Description of the System</b>	<b>17</b>
2.1	System Information	17
2.2	System Components	17
2.3	Locator Components	18
2.4	Signal Transmitter Components	18
2.5	Li-Ion Battery Pack - optionally available	18
<b>3</b>	<b>Operation of the Locator</b>	<b>20</b>
3.1	Changing the Battery	20
3.2	Keyboard	20
3.3	Turning On / Turning Off	21
3.4	Display Screens	22
	3.4.1 The Customisation Screens	22
	3.4.2 The Locate Screen	23
	3.4.3 The Depth Estimation Screens	25
3.5	Locator Menu	27
	3.5.1 Access and Navigation	27
	3.5.2 Menu Options	28
3.6	Search Modes	32
<b>4</b>	<b>Operation of the Transmitter</b>	<b>35</b>
4.1	Changing the Battery	35
4.2	Keyboard	35
4.3	Turning On / Turning Off	36
<b>5</b>	<b>Applications</b>	<b>37</b>
5.1	How to Pinpoint a Utility	37
5.2	How to Trace a Utility	38
5.3	How to Conduct a Sweep Search	39
5.4	Using the Transmitter in Induction Mode	40
	5.4.1 General Information	40
	5.4.2 Induction Mode: Nulling-Out Method	42
	5.4.3 Induction Mode: Parallel-Sweep Method	43
	5.4.4 Induction Mode: Radial-Sweep Method	44
5.5	Using the Transmitter in Connection Mode	45
	5.5.1 General Information	45
	5.5.2 Direct Connection Mode	45
	5.5.3 Connection Mode: 83 kHz and 131 kHz Cable-Wrap Technique	47
	5.5.4 How to use Digital Trim	49
5.6	How to Use the Trace Rod	49
	5.6.1 General Information	49
	5.6.2 Locating a Utility Using the Trace Rod	49

5.7	How to Use the Transmitter Clamps	52
5.7.1	General Information	52
5.7.2	Using a Transmitter Clamp to connect to Cable Utilities	53
5.8	How to Use the Property Plug Connector	54
5.8.1	General Information	54
5.8.2	Locating a Utility Using the Property Plug Connector	54
5.9	How to Use the Sondes	55
5.9.1	General Information	55
<b>6</b>	<b>Estimating Depth and Current of a Utility</b>	<b>57</b>
6.1	Utility Line Depth	57
6.2	Sonde Depth	58
6.3	Depth Code Information	58
6.4	Utility Current Measurement	59
<b>7</b>	<b>Connectivity</b>	<b>60</b>
7.1	Locator Bluetooth Connectivity	60
7.2	Locator USB Connectivity	62
7.3	Transmitter USB Connectivity	62
<b>8</b>	<b>Locator Memory and GPS</b>	<b>64</b>
8.1	Internal Memory	64
8.2	Internal GPS	64
8.3	Point of Interest	64
<b>9</b>	<b>Power Supply</b>	<b>66</b>
9.1	Alkaline Batteries	66
9.2	Li-Ion Battery	66
9.2.1	Operating Principles	67
9.2.1.1	Charging the Li-Ion Battery Pack	67
<b>10</b>	<b>Functional Checks</b>	<b>70</b>
10.1	Locator Health Check	70
10.2	Calibration Verification	71
10.3	Locator Fault Codes	73
10.4	Transmitter Functional Check	73
10.5	Functional Check of the Trace Rod	75
10.6	Functional Check of the Sonde	75
<b>11</b>	<b>Care and Transport</b>	<b>77</b>
11.1	Transport	77
11.2	Storage	77
11.3	Cleaning and Drying	77
<b>12</b>	<b>Technical Data</b>	<b>79</b>
12.1	General Technical Data	79
12.1.1	Transmitter Technical Data	79
12.1.2	Locator Technical Data	80
12.1.3	Conductive Rod Technical Data	83
12.1.4	Property Plug Connector Technical Data	83
12.2	Conformity to National Regulations	84
<b>Appendix A</b>	<b>Time Zone Offsets</b>	<b>90</b>

# 1 Safety Directions

## 1.1 General

### Description

The following directions enable the person responsible for the product, and the person who actually uses the equipment, to anticipate and avoid operational hazards.

The person responsible for the product must ensure that all users understand these directions and adhere to them.

To ensure the protection provided by this equipment is not impaired, do not use this equipment in any manner other than that specified in this manual.

### About warning messages





Warning messages are an essential part of the safety concept of the instrument. They appear wherever hazards or hazardous situations can occur.

#### Warning messages...

- make the user alert about direct and indirect hazards concerning the use of the product.
- contain general rules of behaviour.

For the users' safety, all safety instructions and safety messages shall be strictly observed and followed! Therefore, the manual must always be available to all persons performing any tasks described here.

**DANGER, WARNING, CAUTION** and **NOTICE** are standardised signal words for identifying levels of hazards and risks related to personal injury and property damage. For your safety, it is important to read and fully understand the following table with the different signal words and their definitions! Supplementary safety information symbols may be placed within a warning message as well as supplementary text.

Type	Description
 <b>DANGER</b>	Indicates an imminently hazardous situation which, if not avoided, will result in death or serious injury.
 <b>WARNING</b>	Indicates a potentially hazardous situation or an unintended use which, if not avoided, could result in death or serious injury.
 <b>CAUTION</b>	Indicates a potentially hazardous situation or an unintended use which, if not avoided, may result in minor or moderate injury.
 <b>NOTICE</b>	Indicates a potentially hazardous situation or an unintended use which, if not avoided, may result in appreciable material, financial and environmental damage.
	Important paragraphs which must be adhered to in practice as they enable the product to be used in a technically correct and efficient manner.

## 1.2 Definition of Use

### Intended use

The products are intended to be used for the following applications:

- Detection, localisation and estimation of the depth of underground utilities with the use of approved accessories
- Localisation, recording and storage of product usage
- Data transfer with Bluetooth
- Data communication with external appliances

**Reasonably foreseeable misuse**

- Use of the product without instructions
- Use outside of the intended use and limits
- Disabling of safety systems
- Removal of hazard notices
- Opening the product using tools, for example a screwdriver, unless this is permitted for certain functions
- Modification or conversion of the product
- Use after misappropriation
- Use of products with recognisable damage or defects
- Use with accessories from other manufacturers without the prior explicit approval of Leica Geosystems

**1.3**

**Limits of Use**

**Environment**

Suitable for use in an atmosphere appropriate for permanent human habitation. Not suitable for use in aggressive or explosive environments.

**WARNING**

**Working in hazardous areas or close to electrical installations or similar situations**

Life Risk.

**Precautions:**

- ▶ Local safety authorities and safety experts must be contacted by the person responsible for the product before working in such conditions.

**1.4**

**Responsibilities**

**Manufacturer of the product**

Leica Geosystems AG, CH-9435 Heerbrugg, hereinafter referred to as Leica Geosystems, is responsible for supplying the product, including the User Manual and original accessories, in a safe condition.

**Person responsible for the product**

The person responsible for the product has the following duties:

- To understand the safety instructions on the product and the instructions in the User Manual
- To ensure that the product is used in accordance with the instructions
- To be familiar with local regulations relating to safety and accident prevention
- To stop operating the system and inform Leica Geosystems immediately if the product and the application become unsafe
- To ensure that the national laws, regulations and conditions for the operation of the products are respected

## 1.5

## Hazards of Use

---

### 1.5.1

### General

---

#### **NOTICE**

#### **Dropping, misusing, modifying, storing the product for long periods or transporting the product**

Watch out for erroneous measurement results.

#### **Precautions:**

- ▶ Periodically carry out test measurements and perform the field adjustments indicated in the User Manual, particularly after the product has been subjected to abnormal use as well as before and after important measurements.
- 

#### **DANGER**

Because of the risk of electrocution, it is dangerous to use the product in the vicinity of electrical installations such as power cables or electrical railways.

#### **Precautions:**

- ▶ Keep at a safe distance from electrical installations. If it is essential to work in this environment, first contact the safety authorities responsible for the electrical installations and follow their instructions.
- 

#### **WARNING**

#### **Electric shock though working on or near live electrical utilities**

This can lead to dangerous situations which may result in damage or personal injury.

#### **Precautions:**

- ▶ Do not exceed equipment's recommended ratings and instructions of use.
  - ▶ Inspect equipment's cables and accessories for damage, do not use if faulty.
  - ▶ Do not work on electrically live power utilities unless you are properly qualified.
  - ▶ Use personal protective equipment rated for the utilities voltage and current.
  - ▶ Familiarise yourself with National and Work regulations governing safety and accident prevention.
- 

#### **WARNING**

#### **Distraction/loss of attention**

During dynamic applications, for example stakeout procedures, there is a danger of accidents occurring if the user does not pay attention to the environmental conditions around, for example obstacles, excavations or traffic.

#### **Precautions:**

- ▶ The person responsible for the product must make all users fully aware of the existing dangers.
-



## WARNING

### **Presence of utilities without a detectable signal**

The absence of a positive indication does not guarantee the non-existence of a utility.

Without the use of appropriate accessories, the locators cannot locate non-metallic utilities such as plastic pipes, typically used by the water and gas utilities.

#### **Precautions:**

- ▶ Always excavate with care.
- 

## WARNING

### **Depth reading on locator might differ from actual depth of utility**

When taking a depth reading, the depth is calculated as distance to the centre of a utility or to a sonde within the utility. Depending on the diameter of a utility, the depth reading might differ from the actual depth of the utility.

This specifically applies when the signal for depth estimation is produced by a sonde lying in a large-diameter pipe or duct.

#### **Precautions:**

- ▶ Always take into account allowances for the diameter of a utility.
- 

## WARNING

### **Inadequate securing of the working site**

This can lead to dangerous situations, for example in traffic, on building sites and at industrial installations.

#### **Precautions:**

- ▶ Always ensure that the working site is adequately secured.
  - ▶ Adhere to the regulations governing safety, accident prevention and road traffic.
- 

## WARNING

### **Inappropriate mechanical influences to batteries**

During the transport, shipping or disposal of batteries it is possible for inappropriate mechanical influences to constitute a fire hazard.

#### **Precautions:**

- ▶ Before shipping the product or disposing it, discharge the batteries by the product until they are flat.
  - ▶ When transporting or shipping batteries, the person in charge of the product must ensure that the applicable national and international rules and regulations are observed.
  - ▶ Before transportation or shipping, contact your local passenger or freight transport company.
-

### **WARNING**

A hazardous signal can be present at the transmitter output when used in connection mode and on the attached accessories and live utility itself.

#### **Precautions:**

- ▶ Take care when handling exposed or non-insulated connections. Notify others who may be working on or around the utility.
- 

### **WARNING**

#### **Exposure of batteries to high mechanical stress, high ambient temperatures or immersion into fluids**

This can cause leakage, fire or explosion of the batteries.

#### **Precautions:**

- ▶ Protect the batteries from mechanical influences and high ambient temperatures.
  - ▶ Consider the product's IP class restrictions in chapter [12 Technical Data](#).
  - ▶ Do not drop or immerse the product into fluids.
- 

### **WARNING**

#### **Short circuit of battery terminals**

If battery terminals are short circuited e.g. by coming in contact with jewellery, keys, metallised paper or other metals, the battery can overheat and cause injury or fire, for example by storing or transporting in pockets.

#### **Precautions:**

- ▶ Make sure that the battery terminals do not come into contact with metallic/conductive objects.
- 

### **WARNING**

#### **Unauthorised opening of the product**

Either of the following actions may cause you to receive an electric shock:

- Touching live components
- Using the product after incorrect attempts were made to carry out repairs

#### **Precautions:**

- ▶ Do not open the product!
  - ▶ Only authorised Leica Geosystems Service Centres are entitled to repair these products.
-

## WARNING

### Improper disposal

If the product is improperly disposed of, the following can happen:

- If polymer parts are burnt, poisonous gases are produced which may impair health.
- If batteries are damaged or are heated strongly, they can explode and cause poisoning, burning, corrosion or environmental contamination.
- By disposing of the product irresponsibly you may enable unauthorised persons to use it in contravention of the regulations, exposing themselves and third parties to the risk of severe injury and rendering the environment liable to contamination.

### Precautions:

▶



The product must not be disposed with household waste. Dispose of the product appropriately in accordance with the national regulations in force in your country. Always prevent access to the product by unauthorised personnel.

Product-specific treatment and waste management information can be received from your Leica Geosystems distributor.

## WARNING

### Improperly repaired equipment

Risk of injuries to users and equipment destruction due to lack of repair knowledge.

### Precautions:

- ▶ Only authorised Leica Geosystems Service Centres are entitled to repair these products.

## 1.5.2

### Using the Product with a Signal Transmitter

## DANGER

### Clipping a transmitter clamp around a live utility

When a transmitter clamp is clipped around a live utility, a hazardous signal might be present on the utility or at the transmitter plug connector, causing you to receive an electric shock.

### Precautions:

- ▶ Do not clip a transmitter clamp around live utilities that have impaired or no insulation.
- ▶ Always ensure that the transmitter plug connector is connected to the transmitter before you clip the transmitter clamp around a live utility.

 **DANGER**

**Connecting the cable set of the transmitter to a live utility**

Connecting the cable set of the transmitter directly to a live utility can cause you to receive an electric shock.

**Precautions:**

- ▶ Never connect the cable set of the transmitter directly to a live electrical utility.

 **DANGER**

**Power output of signal transmitter**

The signal transmitter can output potentially lethal voltages!

**Precautions:**

- ▶ Take care when using the maximum power output of the signal transmitter.
- ▶ Take care when handling exposed or non-insulated connections, including the transmitter's cable set, the earth pin and the connection to the utility.
- ▶ Notify others who may be working on or around the utility.

 **WARNING**

**Removing the battery pack of the signal transmitter**

Removing the battery pack of the signal transmitter might cause you to receive an electric shock.

**Precautions:**

- ▶ Switch the signal transmitter off and remove any cable set or accessories from the connection socket before removing the battery pack.

 **WARNING**

**Battery pack of the signal transmitter may get hot after prolonged use**

Risk of burning injuries.

**Precautions:**

- ▶ Avoid touching the hot battery pack.
- ▶ Allow the battery pack to cool down before removing it.

**1.5.3**

**Connecting the Cable Set of the Transmitter to a Live Utility**

**Overvoltage Category  
1**

These instruments are not intended to be connected to the mains supply. CAT 1 is the lowest overvoltage category and applies to circuits that contain measures to limit overvoltage transients to a low level.

 **WARNING**

**Overvoltage to transmitter**

Directly connecting the transmitter to a 230 V AC source will cause irreparable damage to the transmitter electronics. And it can pose a significant risk of injury or potential fatality to the operator of the instrument.

**Precautions:**

- ▶ Always check the live conductor is de-energized before a connection is made.

**1.6**

**Description**

**Electromagnetic Compatibility (EMC)**

The term Electromagnetic Compatibility is taken to mean the capability of the product to function smoothly in an environment where electromagnetic radiation and electrostatic discharges are present, and without causing electromagnetic disturbances to other equipment.

 **CAUTION**

**Electromagnetic radiation**

Electromagnetic radiation can cause disturbances in other equipment.

**Precautions:**

- ▶ Although the product meets the strict regulations and standards which are in force in this respect, Leica Geosystems cannot completely exclude the possibility that other equipment may be disturbed.

 **CAUTION**

**Use of the product with accessories from other manufacturers. For example, field computers, personal computers or other electronic equipment, non-standard cables or external batteries**

This may cause disturbances in other equipment.

**Precautions:**

- ▶ Use only the equipment and accessories recommended by Leica Geosystems.
- ▶ When combined with the product, other accessories must meet the strict requirements stipulated by the guidelines and standards.
- ▶ When using computers, two-way radios or other electronic equipment, pay attention to the information about electromagnetic compatibility provided by the manufacturer.

### CAUTION

#### **Intense electromagnetic radiation. For example, near radio transmitters, transponders, two-way radios or diesel generators**

Although the product meets the strict regulations and standards which are in force in this respect, Leica Geosystems cannot completely exclude the possibility that the function of the product may be disturbed in such an electromagnetic environment.

#### **Precautions:**

- ▶ Check the plausibility of results obtained under these conditions.

### CAUTION

#### **Electromagnetic radiation due to improper connection of cables**

If the product is operated with connecting cables, attached at only one of their two ends, the permitted level of electromagnetic radiation may be exceeded and the correct functioning of other products may be impaired. For example, external supply cables or interface cables.

#### **Precautions:**

- ▶ While the product is in use, connecting cables, for example product to external battery or product to computer, must be connected at both ends.

### WARNING

#### **Use of product with radio or digital cellular phone devices**

Electromagnetic fields can cause disturbances in other equipment, installations, medical devices, for example pacemakers or hearing aids, and aircrafts. Electromagnetic fields can also affect humans and animals.

#### **Precautions:**

- ▶ Although the product meets the strict regulations and standards which are in force in this respect, Leica Geosystems cannot completely exclude the possibility that other equipment can be disturbed or that humans or animals can be affected.
- ▶ Do not operate the product with radio or digital cellular phone devices in the vicinity of filling stations or chemical installations, or in other areas where an explosion hazard exists.
- ▶ Do not operate the product with radio or digital cellular phone devices near medical equipment.
- ▶ Do not operate the product with radio or digital cellular phone devices in aircrafts.
- ▶ Do not operate the product with radio or digital cellular phone devices for long periods with the product immediately next to your body.

## 1.7

### China ROHS

### Disposal - ACPEIP Forms



Hereby, Leica Geosystems AG declares that the product/s is/are in compliance with the essential requirements and other relevant provisions applicable to CHINA ROHS (GB/T 26572-2011 and SJ/T 11364-2014).

有毒有害物质或元素-  
ACPEIP (Toxic and  
harmful substances  
or elements – ACPEIP)

中华人民共和国电子信息产品有毒有害物质限量标准  
(依据 SJ/T11364 为标准)

**Control of Pollution, Applicable in the People's Republic of China**  
(Based on the standard SJ/T11364)

In this table is reported the DD300 analysis for CHINA ROHS:

部件名称 Component Name	有毒有害物质或元素 Hazardous Substances					
	铅 (Pb)	汞 (Hg)	镉 (Cd)	六价铬 (Cr (VI))	多溴联 苯 (PBB)	多溴二 苯醚 (PBDE )
金属部件 Metal parts	0	0	0	0	0	0
塑料部件 Plastic parts	x	0	0	0	0	0
电子件 Electronic component	x	0	0	0	0	0
触点 Electrical contacts	0	0	0	0	0	0
线缆和线附件 Cables & cabling accessories	0	0	0	0	0	0

本表格依据 SJ/T 11364 的规定编制。

This table is prepared in accordance with the provisions of SJ/T 11364.

0: 表示该有害物质在该部件所有均质材料中的含量均在 GB/T 26572 规定的限量要求以下。

0: Indicates that said hazardous substance contained in all of the homogeneous materials for this part is below the limit requirement of GB/T 26572.

x: 表示该有害物质至少在该部件的某一均质材料中的含量超出 GB/T 26572 规定的限量要求。

x: Indicates that said hazardous substance contained in at least one of the homogeneous materials for this part is above the limit requirement of GB/T 26572.

有毒有害物质或元素-  
ACPEIP (Toxic and  
harmful substances  
or elements – ACPEIP)

中华人民共和国电子信息产品有毒有害物质限量标准  
(依据 SJ/T11364 为标准)

**Control of Pollution, Applicable in the People's Republic of China**  
(Based on the standard SJ/T11364)

In this table is reported the DA300 analysis for CHINA ROHS:

部件名称 Component Name	有毒有害物质或元素 Hazardous Substances					
	铅 (Pb)	汞 (Hg)	镉 (Cd)	六价铬 (Cr (VI))	多溴联 苯 (PBB)	多溴二 苯醚 (PBDE )
金属部件 Metal parts	0	0	0	0	0	0
塑料部件 Plastic parts	0	0	0	0	0	0
电子件 Electronic component	x	0	0	0	0	0
触点 Electrical contacts	0	0	0	0	0	0
线缆和线附件 Cables & cabling accessories	0	0	0	0	0	0

本表格依据 SJ/T 11364 的规定编制。

This table is prepared in accordance with the provisions of SJ/T 11364.

0: 表示该有害物质在该部件所有均质材料中的含量均在 GB/T 26572 规定的限量要求以下。

0: Indicates that said hazardous substance contained in all of the homogeneous materials for this part is below the limit requirement of GB/T 26572.

x: 表示该有害物质至少在该部件的某一均质材料中的含量超出 GB/T 26572 规定的限量要求。

x: Indicates that said hazardous substance contained in at least one of the homogeneous materials for this part is above the limit requirement of GB/T 26572.



## 2

## Description of the System

### 2.1

### System Information

#### General description

Locators are used to detect buried conductive utilities that emit an electromagnetic signal. Such a signal is generated as an electrical current passes through the utility.

Signal transmitters are used to apply a distinct signal to utilities with the following intention:

- To improve the detection success.
- To trace the route of a utility.
- To make a depth or current measurement.

Accessories are used with the locator and transmitter to localise the position of utilities, including some that are non-metallic.

The locators and transmitters described within this manual greatly facilitate the search process and help to reduce the dangers and costs associated with utility strikes. However, electromagnetic location depends on the utilities being conductive (metallic) and emitting a signal as current passes through them.



Keep in mind that a locator on its own cannot detect all utilities. Take care when excavating. We recommend that you adopt a safe system which includes the planning of the search process in advance, the use of utility maps, the use of locators and transmitters, and the use of safe digging practices.

### 2.2

### System Components



The delivered components depend on the package ordered.

#### Available system components

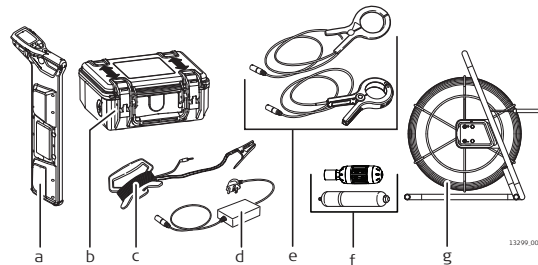

- a Locator
- b Transmitter
- c Transmitter Cable Set Extension
- d Property Plug Connector
- e Transmitter Clamps
- f Sondes
- g Trace Rod (non-metallic utility tracer)

## 2.3

### Locator Components

Description of components DD300 locator



- a Display
- b Locator keyboard
- c USB port
- d Trigger
- e Battery compartment
- f Locator foot (wear part)

## 2.4

### Signal Transmitter Components

Description of transmitter components

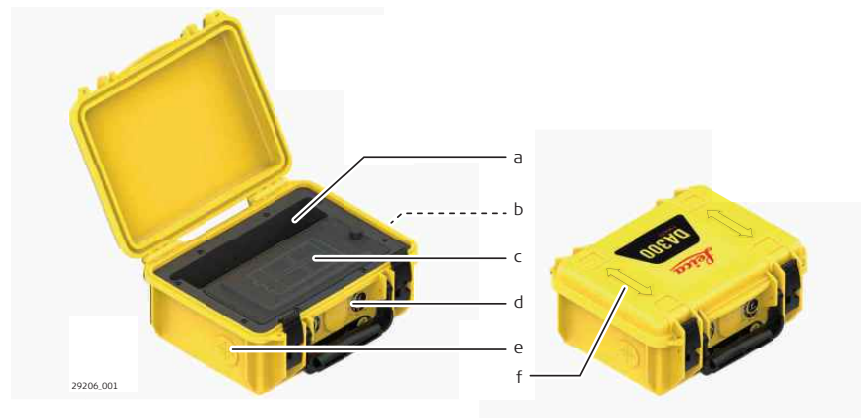

- a Accessory compartment
- b Connection socket
- c 4 × LR20 alkaline batteries compartment
- d Signal transmitter keyboard
- e Speaker
- f Induction arrow

## 2.5

### Li-Ion Battery Pack - optionally available

Li-Ion battery pack

The Li-Ion battery pack is delivered with an energy content as low as possible and needs to be woke up prior to use.

To wake up the Li-Ion battery pack, do the following:

1. Connect the charger plug into the charge jack on the battery pack.



2. Plug the connector into a suitable power source.

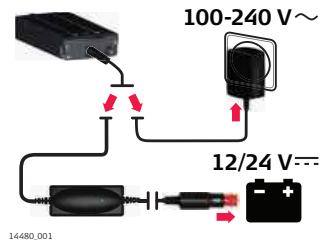

 The battery pack should be fully charged before use.

 **Result:**  
The small LED next to the charge jack flashes at a fast rate to indicate the wake up process, then flashes at a slower rate to indicate that the battery pack is active and charging.

 Applicable to the DD300 Locator and DA300 Transmitter.

## 3 Operation of the Locator

### 3.1 Changing the Battery

#### Changing the batteries

The DD300 Connect - Cable Locator is fitted with four LR20 (D) alkaline batteries.



1. Unscrew the fastener and open the cover.
2. Replace all batteries with four new LR20 (D) type Alkaline batteries.

### 3.2 Keyboard

#### DD300 locator keyboard

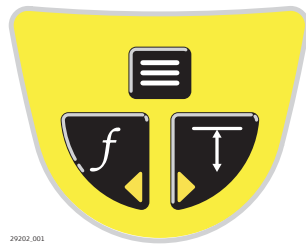

#### Function key

Press and release to change the search mode.



#### Depth Estimation key

Press and release to take a depth reading.



#### Menu key

Press and hold to display the Locator main menu or to return back to the locate screen.  
Press and release to select a menu option.



#### Left navigation key

Press and release to select the previous menu option.



#### Right navigation key

Press and release to select the next menu option.

### 3.3

### Turning On / Turning Off

---

#### Turning on and off the DD300

Press and hold the trigger to turn on and operate the locator.  
Release the trigger to turn off the locator.

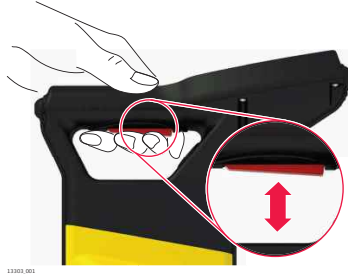

#### Software feature "Always on Trigger":

"Always on Trigger" can be activated in the "Submenu Settings", refer to section [Submenu Settings](#).

Step-by-step:

1. Activate "Always on Trigger" in the "Submenu Settings".
2. Once the trigger is held for three seconds, a power icon will appear, to indicate that the locator will be switched off.
3. Hold for five seconds to cancel power down.

Locator will power automatically down after 10 minutes of inactivity from the last button press.

## 3.4

## Display Screens

### 3.4.1

### The Customisation Screens

#### Set the regional preferences

The customisation screens are displayed only for the first time the locator is put into operation. The screens allow you to set the locator to your regional preferences.

1. Use the navigation keys to alter the selection.



2. Press the menu key to confirm the selection.



#### Units of Measurement

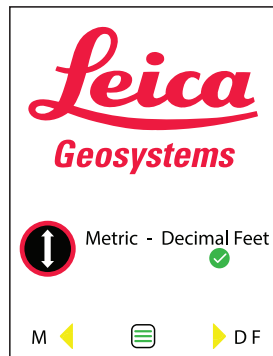

14329\_001

This screen allows you to set up your preferred units of measurement for depth estimation.

To change the units of measurement later on, use the menu option in the Settings menu. Refer to [Submenu Settings](#) within [3.5.2 Menu Options](#).

### Time Zone Settings (model specific option)



This screen allows you to adjust the time zone settings to suit your geographic region. The default time is Universal Time Coordinate (UTC). Time zone offsets are shown in Appendix A [Time Zone Offsets](#). Set up the hours and minutes.

### Confirmation Screen

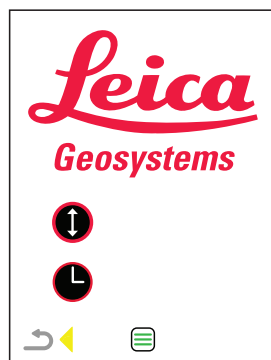

This screen allows you to confirm your changes or to return to the previous screens and update the settings.

To confirm your settings, press the menu key.

To return and update, press the left navigation key.

## 3.4.2

### The Locate Screen

#### Description of the screen

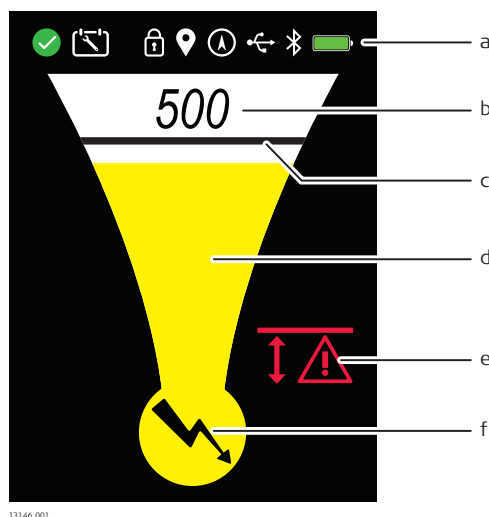

- a) **Status bar**  
Provides information on product and feature selection
- b) **Numeric Peak Indicator**
  - Increases when approaching a utility or sonde and decreases when moving away.
  - Provides the highest peak reading when directly over the utility or sonde.
  - Can be used to distinguish between utilities when a signal transmitter is used.
- c) **Peak Indicator**
  - Indicates the highest peak reading on the locate scale.
  - Remains at the peak position for a short period of time before falling back.
- d) **Locate Scale**
  - Increases when approaching a utility or sonde and decreases when moving away.
  - Provides a peak reading when directly over the utility or sonde.
- e) **Alerts**  
Alerts are displayed to indicate hazardous situations or incorrect use.
- f) **Search Mode Indicator**  
Displays the currently selected search mode.

## Status bar icons

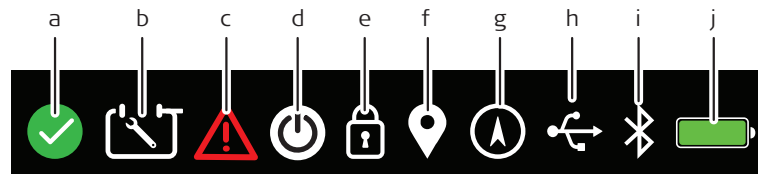

029239.001

- a) **Health Check**
  - ✓ Health Check passed within the last 24 hours.
  - ✗ Health Check process prohibited, e.g. if Health Check is activated in high levels of electrical interference.
- b) **Scheduled Maintenance**  
Planned maintenance is due for the locator. To adjust the settings, refer to [Submenu Maintenance \(3.5.2 Menu Options\)](#).
- c) **Fault Alert**  
Indicates a potential product defect.
- d) **Always on Trigger**  
Indicates Always on Trigger is enabled. Refer to [Turning On / Turning Off](#).
- e) **Mode Lock**  
Locator starts up in the search mode that was used last.
- f) **Point of Interest**  
Model-specific option. Refer to [8.3 Point of Interest](#).
- g) **GPS status**  
Model-specific option. Refer to [8.2 Internal GPS](#).
- h) **USB status**  
Refer to [7.2 Locator USB Connectivity](#).
- i) **Bluetooth status**  
Model-specific option. Refer to [7.1 Locator Bluetooth Connectivity](#).
- j) **Battery condition**  
🔋 Battery Low. Refer to [9 Power Supply](#).



## Locate alerts

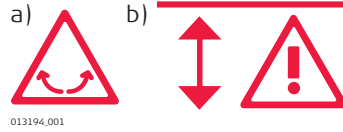

- a) **Swing Alert**  
Indicates excessive swinging during use. To adjust the settings, refer to [Submenu Alerts \(3.5.2 Menu Options\)](#).
- b) **Hazard Zone**  
Indicates the close proximity of a utility. Works in all search modes except in Radio mode. To adjust the settings, refer to [Submenu Alerts \(3.5.2 Menu Options\)](#).

### 3.4.3

## The Depth Estimation Screens

### Utility line depth

This screen indicates the depth of a buried utility.

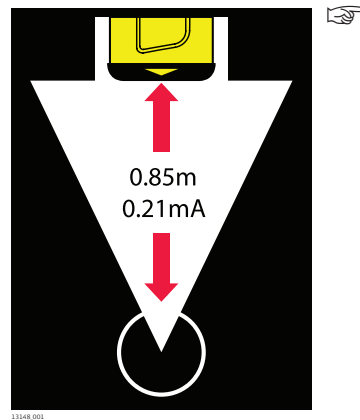

Note that the depth is calculated as distance to the centre of the utility!

### Sonde depth

This screen indicates the depth of a sonde within a pipe.

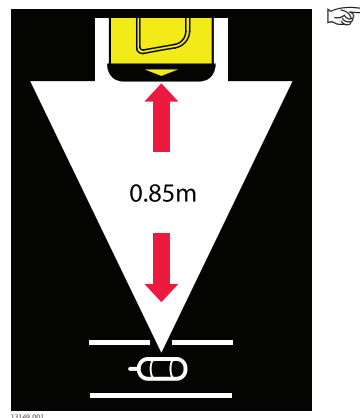

Note that the depth is calculated as distance to the sonde within the pipe!

## Depth out of range

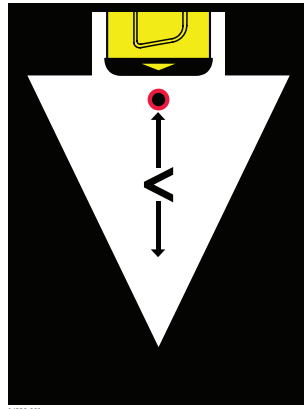

This screen indicates that the depth of the utility or sonde is less than the minimum depth range.

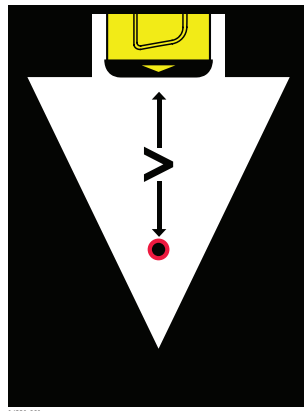

This screen indicates that the depth of the utility or sonde is greater than the maximum depth range.

## Signal out of range

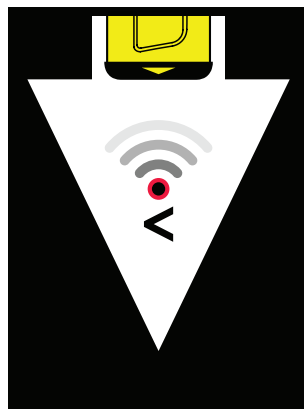

This screen indicates that the signal source is too low to provide a depth reading.



This screen indicates that the signal source is too high to provide a depth reading.

### 3.5

### Locator Menu

#### 3.5.1

#### Access and Navigation

##### Locator main menu and submenus

The Locator menu is used to display information or to update settings. A main menu is used to display the main categories. A submenu displays the available options for the selected category.

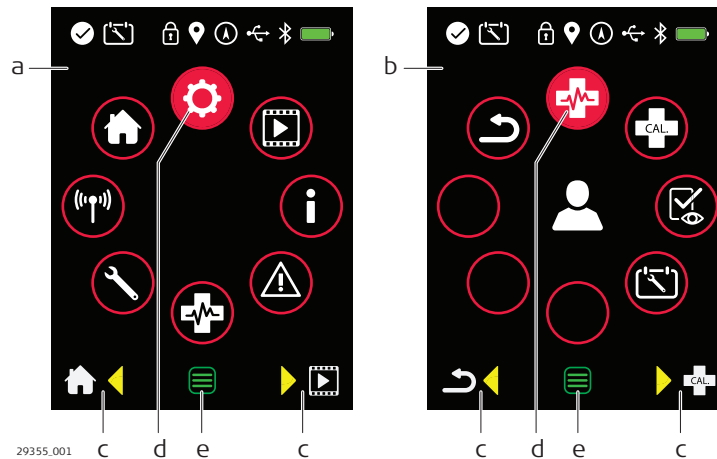

- a Locator main menu
- b Submenu (Example)
- c On-screen guidance arrows that indicate the previous and next menu option.
- d Currently highlighted menu option.
- e On-screen menu icon. A green icon indicates an accessible option, a grey icon indicates a read-only option.

##### How to access and navigate through the menu

- The Locator must be switched on throughout the process.
- Press and hold the menu key to display the Locator main menu.
- When displaying the main menu, the option **Settings** is highlighted by default.
- Use the navigation keys to highlight a menu option.
- Press and release the menu key to select the highlighted option. *The submenu for the selected option is displayed.*



Use the navigation keys to highlight a menu option.



Press and release the menu key to select the highlighted option.



Use the navigation keys to adjust the option.



Press and release the menu key to confirm the changes and return to the submenu.



Select this option to go back one level.



Select this option to close the menu and display the Locate screen. You can also press and hold the menu key to display the Locate screen.

### Commonly used menu icons

Icon	Description
	This icon indicates an active option or a good condition.
	This icon indicates an inactive option or a failed condition.
	This icon indicates a prohibited use or a fault.
	This icon indicates a user defined or activated option.

### 3.5.2

### Menu Options

#### Main menu



Select this option to perform a Health Check. **Health Check** is a function check on the locators hardware and software. Refer to [10.1 Locator Health Check](#).



**Videos.** Contains short animations on key product features or product usage.



**Information.** Contains options for product and owner information.



**Alerts.** Contains options for alerts and configuration.



**Home.** Select this option to return to the Locate screen.



**Communication.** Contains options for communication (connectivity) and configuration.



**Settings.** Contains options for product settings and configuration.



### Maintenance.

Contains options for maintenance and configuration.

## Submenu Videos



Select from the main menu.



Select this option to play a short animation on how to use the locator in Power or Radio mode.



Select this option to play a short animation on how to use the locator with the signal transmitter in Connection Mode.



Select this option to play a short animation on how to use the locator with the signal transmitter in Induction mode.



Select this option to play a short animation on how to use the locator with a sonde.



Select this option to play a short animation on how to perform a product Health Check.



Select this option to play a short animation on how to perform a calibration verification.



Select this option to return to the main menu.

## Submenu Information



Select from the main menu.



Select this option to display company or owner information.



Select this option to display company or owner telephone number.



Select this option to display user name or fleet number.



Select this option to display product information, for example serial number.



Select this option to display the e-mail address.



Select this option to display the web address.



Select this option to return to the main menu.

## Submenu Alerts



Select  from the main menu.



Select this option to adjust the Hazard Zone activation point.

Available settings:

-  (OFF): Alert function is not active.
- 0.3 m (12 inches): Alert is displayed if a utility is detected within the defined range.
- 0.5 m (20 inches): Alert is displayed if a utility is detected within the defined range.



Select this option to adjust the Swing Alert settings.

Available settings:

-  (ON)
-  (OFF)



Select this option to display the fault code.

 Indicates a product fault. The fault code is displayed. For a list of fault codes, refer to [10.3 Locator Fault Codes](#).

 Indicates that the product condition is good.



Select this option to return to the main menu.

## Submenu Maintenance



Select  from the main menu.



Select this option to adjust the Health Check activation.

Available settings:

-  User defined
- **DD:** Daily
- **MM:** Monthly



Displays the number of months to the next calibration.



Select this option to display the recent maintenance history.

Press and release the menu key to display the report.



Select this option to adjust the scheduled maintenance settings.

Available settings: ON () or OFF ()



Select this option to return to the main menu.

## Submenu Settings



Select  from the main menu.



Select this option to adjust the products volume level.



Select this option to adjust the Always on Trigger setting.

Available settings:

-  (ON)
-  (OFF)



Select this option to adjust the Numeric Peak Indicator.

Available settings:

- (ON)
- (OFF)



Select this option to adjust the display time for the Peak Indicator.

Available settings:

- (ON)
- (OFF)



Select this option to adjust the Digital Trim setting.

Available settings:

- (ON)
- (OFF)



Select this option to adjust the Mode Lock setting.

Available settings:

- ON: Locator starts up in the search mode that was used last.
- OFF: Locator starts up in the default search mode.



Select this option to adjust the measurement units for depth estimation.

Available settings:

- Metric
- Decimal Feet
- Off (controlled by external software)



Select this option to adjust the Point-of-Interest setting.

Available settings:

- Select a marker in the desired colour to activate the POI function.
- Select to turn off the POI function.



Select this option to adjust the display brightness.



Select this option to return to the main menu.

## Submenu Communication



Select from the main menu.



### Model-specific option:

Select this option to adjust the products Bluetooth options.

Available settings:

- DD SMART
- **BT1:** Backward compatibility with Bluetooth-enabled iSeries locators.
- **BT2:** Backward compatibility with Bluetooth-enabled iSeries locators.
- User configurable option, can be customised using the locators management software.
- Bluetooth is turned off.

Refer to [7.1 Locator Bluetooth Connectivity](#).







Select this option to return to the main menu.

## 3.6

## Search Modes

### Available search modes

Search Mode	Description
Auto mode	<p>Combined detection of Power and Radio modes.</p> <p> This mode facilitates a one-step sweep search process.</p>
Power mode	<p>This mode is used to detect electrical cables.</p> <p> Power mode is dependent on an electrical current flowing through a cable. Keep in mind that not all electrical cables carry a detectable signal and thus pose a serious risk, for example supplies to unilluminated street lights, unoccupied buildings or balanced three-phase cables.</p>
Radio mode	<p>This mode is used to detect metallic pipes or cables, including telecoms and electrical.</p> <p> Radio mode is dependent on reradiated radio waves originating from radio masts. Keep in mind that signal availability can vary or be restricted depending on factors including line of site, signal application or routine mast maintenance.</p>
Signal Transmitter mode	<p>Used in conjunction with a signal transmitter:</p> <ul style="list-style-type: none"><li>• To improve the detectability of utilities.</li><li>• To trace a specific utility.</li><li>• To make a depth or current measurement.</li></ul> <p> Keep in mind the following:</p> <ul style="list-style-type: none"><li>• Higher frequencies couple onto utilities more easily than lower frequencies.</li><li>• Higher frequencies travel shorter distances; the higher the frequency the less the distance travelled.</li><li>• Higher frequencies are likely to couple onto other utilities; the higher the frequency the greater the spread.</li><li>• Higher frequencies are useful for avoidance activities.</li></ul> <p>Example: A 131 kHz frequency has a greater ability to couple onto other utilities, jump over insulated pipe joints, travel down small-diameter cables or pot-ended (terminated) cables.</p>



Search Mode	Description
Sonde mode	<p>Used in conjunction with a sonde:</p> <ul style="list-style-type: none"> <li>To trace the route of a pipe or duct, including non-metallic variants.</li> <li>To locate a blockage or collapse.</li> <li>To make a depth measurement.</li> </ul> <p> Keep in mind that various sondes are available for specific task-based applications:</p> <ul style="list-style-type: none"> <li>Sondes with higher frequencies are used for generic pipe or duct tracing.</li> <li>Lower frequencies (512 Hz, 640 Hz) work best for metal pipes.</li> </ul>

**WARNING**

**Presence of utilities without a detectable signal**

The absence of a positive indication does not guarantee the non-existence of a utility. Without the use of appropriate accessories, the locators cannot locate non-metallic utilities such as plastic pipes, typically used by the water and gas utilities.

**Precautions:**

- ▶ Always excavate with care.

**How to select a search mode**



Press the Function key on the locator keyboard to select a search mode.

The Search Mode indicator cycles through in the following order:

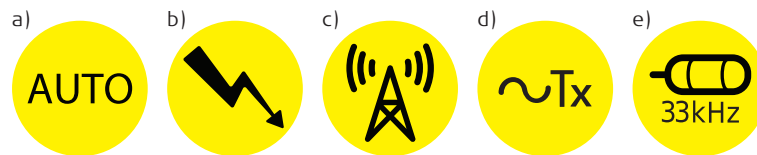

13195.001

- a Auto Mode
- b Power Mode
- c Radio Mode
- d Signal Transmitter Mode
- e Sonde Mode

**Frequency selection**

**Using the locator with a signal transmitter**

The Signal Transmitter mode features an auto-select option (indicated by **~TX**).

In Auto mode the locator locks onto the signal transmitters output and updates the Search Mode indicator with the selected frequency.









Auto mode is influenced by the ability to detect the signal transmitters output. For long distance tracing or low signal outputs it is recommended to manually select the required frequency on the locator.

## Using the locator with a sonde

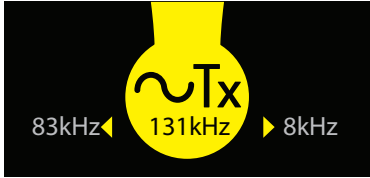
The default search mode when using a sonde is Sonde Mode (33 kHz).

### Manual selection of a signal transmitter or sonde frequency

Action	Result
1. Press the Function key to select either the Signal Transmitter or the Sonde mode. 	
2. Press and release the menu key. 	<i>The Search Mode indicator displays the currently selected frequency. The on-screen guidance arrows indicate the previous and next frequency value.</i>  <small>29242_001</small>
3. Use the navigation keys to select the required frequency. 	
4. Press and release the menu key to confirm the selection. 	<i>The Search Mode indicator displays the selected frequency.</i>  <small>13325_001</small>
 To save the selection throughout the locator's use, set the Mode Lock setting to ON. Refer to <a href="#">Submenu Settings</a> within <a href="#">3.5.2 Menu Options</a> .	

## 4

## Operation of the Transmitter

### 4.1

### Changing the Battery

#### Changing the batteries

The DA300 Transmitter is fitted with four LR20 (D) alkaline batteries.



1. Unscrew the fastener and open the cover.
2. Replace all batteries with four new LR20 (D) type Alkaline batteries.

### 4.2

### Keyboard

#### Transmitter keyboard

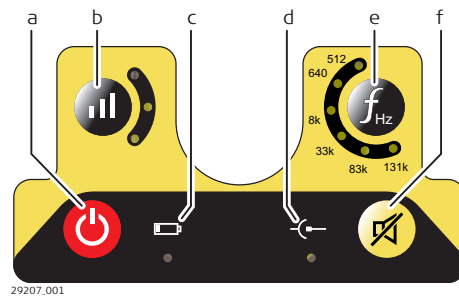

- a Power key
- b Power Output key and LED indicators
- c Low Battery LED indicator
- d Connection Mode LED indicator
- e Frequency key and LED indicators
- f Mute key

## 4.3

### Turning On / Turning Off

---

#### Turning on and off the transmitter

Press the Power key to turn the transmitter on or off.



## 5

## Applications

### 5.1

### How to Pinpoint a Utility

#### Pinpointing process

To help you pinpoint a utility, the locator provides a visual and an audible response.

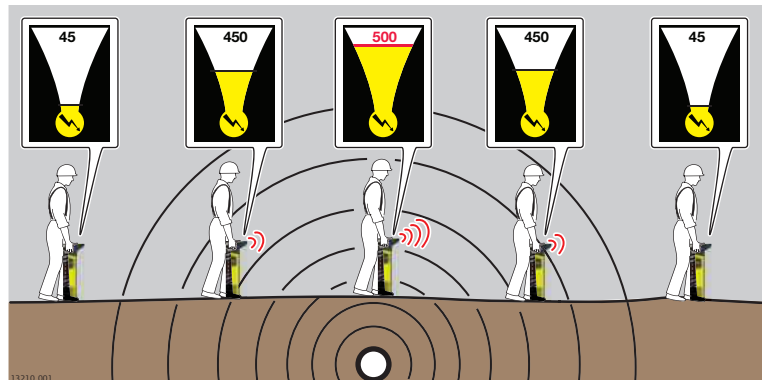

#### Visual response

When the locator is positioned directly over a utility and at 90° to it, the Locate screen displays a peak reading. Refer to [3.4.2 The Locate Screen](#).

#### Locate Scale



- Increases when approaching a utility or sonde and decreases when moving away.
- Provides a peak reading when directly over the utility or sonde.
- Decreases when moving away from the utility.

#### Peak Indicator



- Indicates the highest peak reading on the locate scale.
- Remains at the peak position for a short period of time before falling back.

#### Numeric Peak Indicator

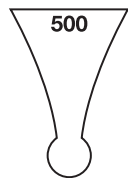

- Increases when approaching a utility or sonde and decreases when moving away.
- Provides the highest peak reading when directly over the utility or sonde.
- Decreases when moving away from the utility.
- Can be used to distinguish between utilities when a signal transmitter is used.

## Digital Trim



**Software feature:** Digital trim is used to scale down a saturated signal or to scale up a low signal from a deep utility. This will help the operator to pinpoint a utility in an environment, where coupling and signal distortion may be present.

Digital trim can be activated on the submenu "Settings". Refer to [Menu Options](#).

This option is applicable for all manual detection modes, passive and active. (Power, Radio, 8 kHz, 33 kHz, 83 kHz, and 131 kHz) Not available in AUTO mode. Once activated, the Digital trim icon appears on the locate screen.

Once activated, the Digital trim icon  appears on the locate screen under saturated condition.

## Audible response

To assist in the pinpointing process, the audio output automatically adjusts over the peak reading to provide a narrower response.



Mark the position of a utility with marker paint, pegs, flags or something similar. Never drive pegs into the ground over the utility!



The signal strength indicators do not indicate the size, depth or type of a utility.



To ascertain an estimated depth of the utility, use a signal transmitter or a sonde. Refer to [6 Estimating Depth and Current of a Utility](#).

## 5.2

### How to Trace a Utility

#### Tracing process

1. Pinpoint a utility by finding the peak reading. The peak reading is found when the locator is positioned directly over a utility and at 90° to it.

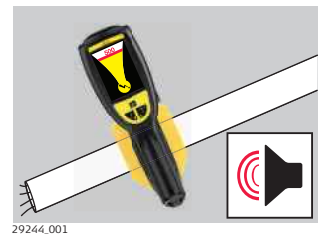

2. Rotate the Locator around its axis until the signal strength indicators are at a minimum.

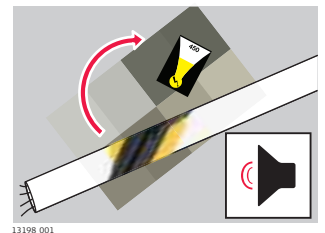

3. When the signal strength indicators are at a minimum, the blade of the locator is in line with the utility and indicates its direction.

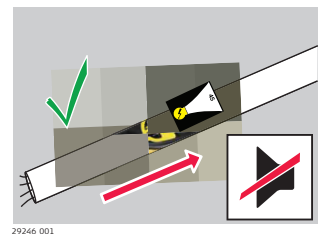

4. Trace the route of the utility by repeating the following process:
  - Pinpoint the utility.
  - Determine the direction of the utility.
  - Follow the direction of the utility.

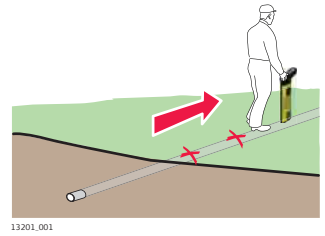

## 5.3

### How to Conduct a Sweep Search

#### Sweep Search Process

Before the sweep search, define the work area to be excavated and inspect this area for signs of buried utilities, such as:

- Recent trenching
- Buried utility marker posts
- Overhead lines that run down poles and underground
- Access chamber covers

1. Set the locator to Power mode.



Ensure that the locator is held upright and close to the ground. Take care not to swing the locator.

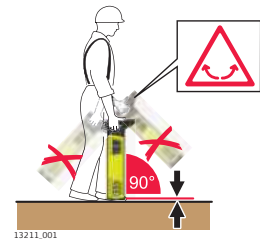

2. Cross the site from left to right until the defined area is covered.

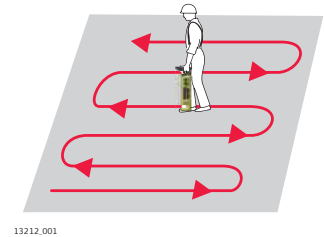

3. Turn through 90 ° and repeat the process.

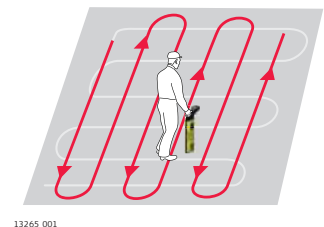

- Pinpoint a utility by finding the peak reading. The peak reading is found when the locator is positioned directly over a utility and at 90° to it. Mark the position of a utility with marker paint, pegs, flags or something similar.

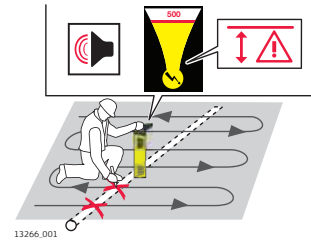

- ➔ Never drive pegs into the ground over the utility!
- ➔ Activate the Hazard Zone alert to indicate the presence of buried utilities which may be close to the surface.

- Set the locator to Smart Radio mode and repeat the sweep search process.

#### Smart Radio mode

With Smart Radio mode, the operator is informed if the detection frequency is above or below the 33 kHz threshold. This is a diagnostic tool to differentiate power signals to radio signals.

Continue with this process until either a signal is detected or you are satisfied that the area has been adequately tested.



- ➔ To conduct a one-step Sweep Search process or to provide a fast scan for large work areas, the locator can be used in Auto mode. To obtain an improved definition of a detected utility, use the locator in an individual mode.

## 5.4

### Using the Transmitter in Induction Mode

#### 5.4.1

#### General Information

##### Induction mode

Induction is a quick and simple way to apply a signal to a utility without the need to make any physical connection to it. The transmitter uses an internal aerial to transmit the signal to the utility.

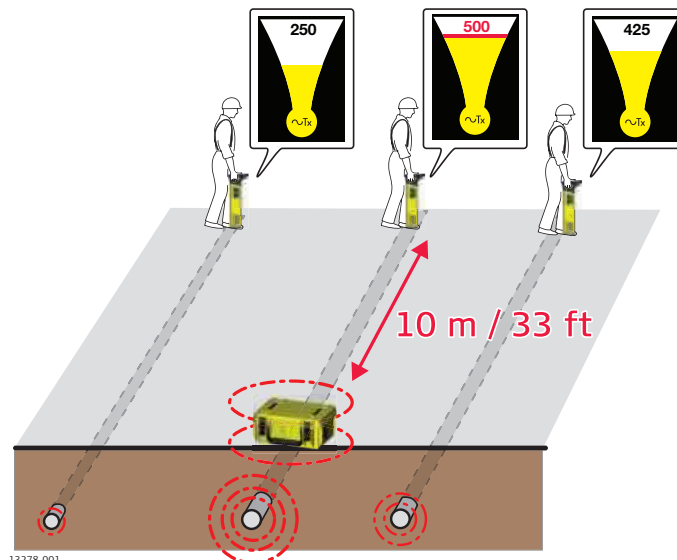



- ☞ Work at least 10 m/33 ft away from the transmitter to avoid airborne signals. Reposition the Transmitter if necessary.
- ☞ Coupling efficiency is best at 33 kHz.
- ☞ The signal can also apply itself to other utilities within close proximity to the transmitter, depending on their depth and direction.
- ☞ To increase the battery life and to reduce the possibility that the signal is applied to adjacent utilities, reduce the signal output.
- ☞ The Numeric Peak Indicator can be used to indicate multiple utilities or to assist tracing. The utility with the maximum value is typically the one closest to the transmitter or the one directly connected to.

### Standard process for Induction mode

1. Turn on the transmitter.

- ☞ Ensure that any connection cables or accessories are disconnected and the battery level is adequate.



29254.001

2. Select the required power output and frequency.

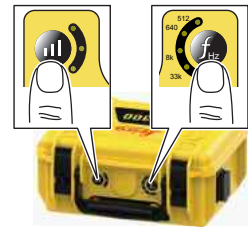

29254.001

3. Place the transmitter over the utility with the arrows running in line with the suspected direction of the utility. The internal aerial directly induces the tracing signal onto the utility.

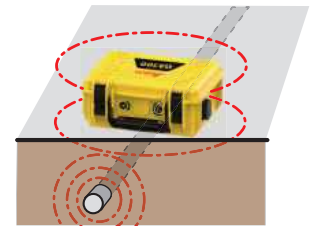

29255.001

4. Set the locator to Signal Transmitter mode and select the required frequency.



29259.001

- Using the Sweep Search process, search the work area until either a signal is detected or you are satisfied that the area has been adequately tested. Refer to [5.3 How to Conduct a Sweep Search](#). Trace a utility as required. Refer to [5.2 How to Trace a Utility](#).

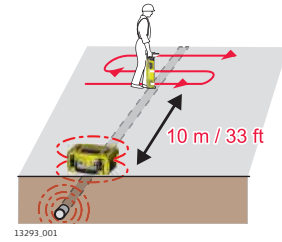

- ☞ Maintain a distance of 10 m/33 ft from the transmitter to avoid airborne signals and a decline in the search process. Reposition the transmitter if required.

## 5.4.2

### Induction Mode: Nulling-Out Method

#### Nulling-Out method

Use the Nulling-Out method to confirm that the locator and transmitter are on the same utility or to identify hidden utilities in close proximity to each other.

- ☞ The transmitter and locator need to be set for use in induction mode. Refer to [Standard process for Induction mode](#).

- Position the locator over the utility with the highest numeric signal strength.

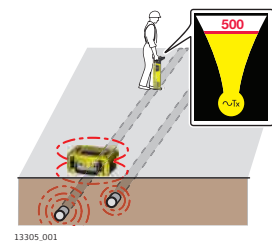

- To confirm that the transmitter and the locator are on the same utility, place the signal transmitter upright and directly over the utility.

- ☞ Either the speaker or the connection socket should be on the ground.

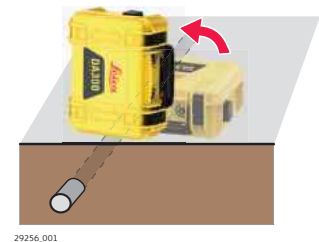

- If the transmitter and the locator are on the same utility, the Numeric Peak Indicator on the locator significantly decreases.

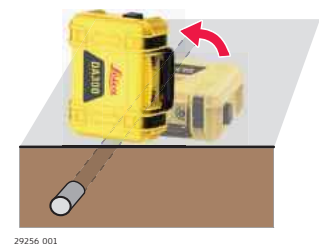

- ☞ The Numeric Peak Indicator on the locator can be used to correct the position of the transmitter. Slightly move the transmitter left or right over the utility until the locate screen of the locator shows the lowest reading. It is possible to obtain the value "000".

4. Using the Sweep Search process, search the work area to identify previously hidden utilities.
  - ☞ Pinpoint and trace utilities until you are satisfied that the area has been adequately tested.

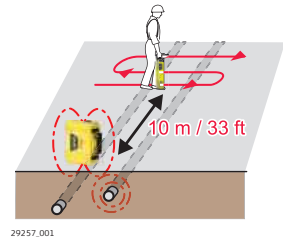

### 5.4.3

### Induction Mode: Parallel-Sweep Method

#### Parallel-Sweep method

Use the Parallel-Sweep method to cover a large area or to verify the presence of utilities before using the standard process for induction mode.

- ☞ Two people are required for this process: one for operating the locator and one for operating the transmitter.
- ☞ Set the transmitter and locator to 33 kHz.

1. **Person operating the transmitter:**  
Hold the transmitter close to the ground with the arrows on the lid vertical and with the lid facing the person who operates the locator.  
**Person operating the locator:**  
Position the locator at a minimum distance of 10 m/33 ft away from the transmitter.

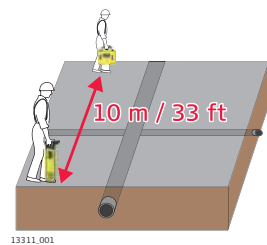

2. **Both persons:**  
Start walking parallel to each other.
  - ☞ The tracing signal is induced directly onto the utility and indicated on the locator.

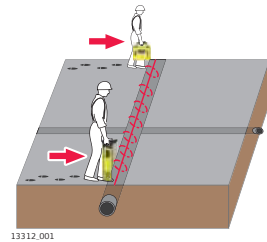

3. In the presence of a detectable utility, the locator emits a tone and the signal strength indicators rise and fall as you pass over the utility. Return to the position where the Locate screen shows a peak reading. Mark the position of a utility with marker paint, pegs, flags or something similar.

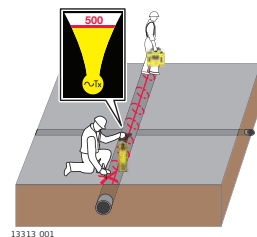

- ☞ Never drive pegs into the ground over the utility!
- ☞ To trace a specific utility, use the pinpointing and tracing methods. Refer to [5.1 How to Pinpoint a Utility](#) and [5.2 How to Trace a Utility](#).

- Turn through 90 ° and repeat the process.

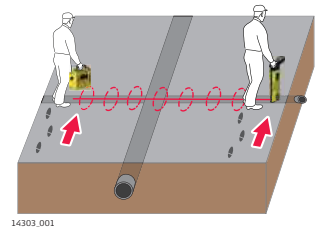

- Pinpoint and trace utilities until you are satisfied that the area has been adequately tested.

## 5.4.4

### Induction Mode: Radial-Sweep Method

#### Radial-Sweep method

Use the Radial-Sweep method to discover utilities coming from a known point such as a telecommunications chamber.

- Two people are required for this process: one for operating the locator and one for operating the transmitter.
- Set the transmitter and locator to 33 kHz.

- Person operating the transmitter:**  
Hold the transmitter close to the ground with the arrows on the lid vertical and with the lid facing the person who operates the locator.

**Person operating the locator:**  
Position the locator at a minimum distance of 10 m/33 ft away from the transmitter.

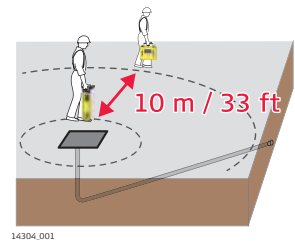

- Both persons:**  
Start walking parallel to each other, circling the target area.

  - The tracing signal is induced directly onto the utility and indicated on the locator.

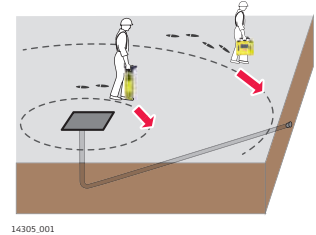

- In the presence of a detectable utility, the locator emits a tone and the signal strength indicators rise and fall as you pass over the utility. Return to the position where the Locate screen shows a peak reading. Mark the position of a utility with marker paint, pegs, flags or something similar.

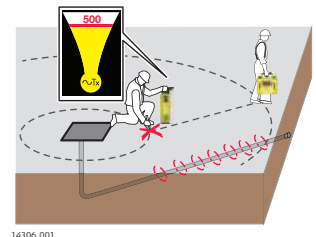

- Never drive pegs into the ground over the utility!
- To trace a specific utility, use the pinpointing and tracing methods. Refer to [5.1 How to Pinpoint a Utility](#) and [5.2 How to Trace a Utility](#).



Pinpoint and trace utilities until you are satisfied that the area has been adequately tested.

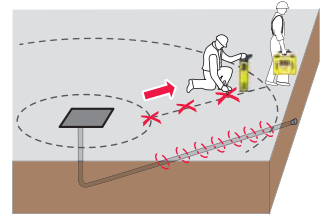

14340.001

## 5.5

## Using the Transmitter in Connection Mode

### 5.5.1

### General Information

#### Connection mode

Connection mode is the most efficient way to apply a signal to a utility. The cable set of the transmitter or any of the available accessories are connected to the utility which is to be traced or identified.



Whenever possible, use the transmitter in connection mode, especially for taking a depth reading.



The Numeric Peak Indicator can be used to indicate multiple utilities or to assist tracing. The utility with the maximum value is typically the one connected to.



The black connection cable can be connected to other metallic structures which go into the ground, such as iron grids or metal covers of access chambers.



In dry conditions it may be necessary to add water around the earth point to get a good connection.



When using the connection cable set, examine the connection points and remove contamination if a continuous audible output is not achieved.



An extension cable is available to extend either the red or black cables on the connection cable set.



Reducing the signal output helps to extend the battery life and to reduce the amount of signal applied to adjacent utilities.

### 5.5.2

### Direct Connection Mode

#### Using the transmitter in Direct Connection mode

1. Plug the transmitter's cable set into the connection socket.



14341.001

2. Ensuring that no utilities are below, push the Earth Pin into the ground and connect the black cable to the Earth Pin.

☞ For more safety, we recommend pushing the Earth pin into the ground at an angle of 45 degrees.

☞ For best performance, position the Earth pin and black cable at 90 degrees to the suspected direction of the utility.

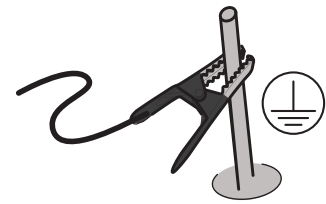

14343\_002

3. Connect the red cable to the utility.

☞ Never connect the red cable directly to an electrical cable!

☞ Connecting the red cable to the metal framework of earth-bonded electrical installations such as street lights, pumps or motorised gate housings, improves the detectability of low-loaded electrical cables. For best performance, connect to bare metal.

☞ Using the combination of 33 kHz and 131 kHz frequencies can improve the detectability of small diameter cables or their short runs.

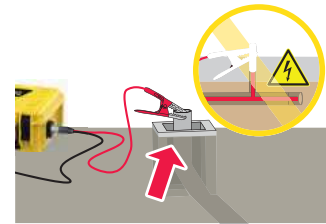

29258\_001

4. Turn on the transmitter.

☞ Ensure that the Connection Mode LED indicator is on and the battery level is adequate.

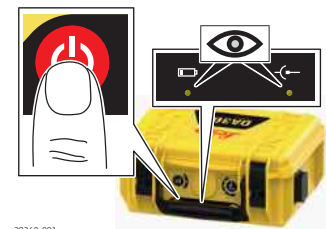

29260\_001

5. Select the required frequency and power output.

To indicate that the tracing signal reaches a good level, the Power Output LED indicator and the audible tone change from pulsed to continuous.

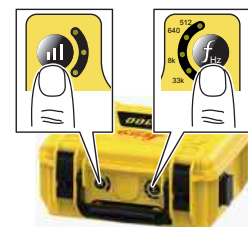

29254\_001

6. Set the locator to Signal Transmitter mode and select the required frequency.

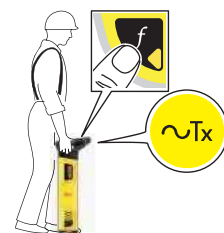

29259\_001

- At a distance of 5 m (16 ft) to the connection point, circle around the connection point.

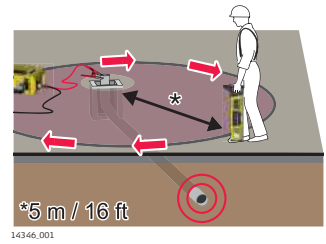

- In the presence of a detectable utility, the locator emits a tone and the signal strength indicators rise and fall as you pass over the utility. Return to the position where the Locate screen shows a peak reading. Mark the position of a utility with marker paint, pegs, flags or something similar.

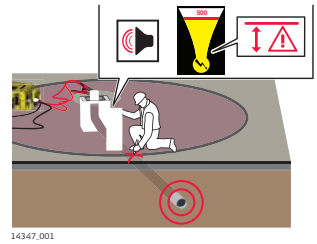

- ☞ Never drive pegs into the ground over the utility!
- ☞ To trace a specific utility, use the pinpointing and tracing methods. Refer to [5.1 How to Pinpoint a Utility](#) and [5.2 How to Trace a Utility](#).

- ☞ Pinpoint and trace utilities until you are satisfied that the area has been adequately tested.

### 5.5.3

### Connection Mode: 83 kHz and 131 kHz Cable-Wrap Technique

#### Using the cable-wrap technique

Sometimes it can be difficult to directly connect the transmitter to a utility. In this case, use the cable-wrap technique to apply a signal to a cable.

- ☞ For this process, the frequency of the transmitter should be set to 131 kHz.



- Plug the transmitters cable set into the connection socket.

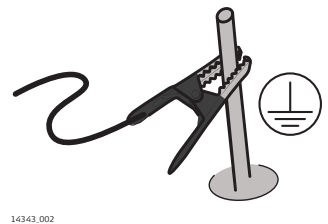

- Ensuring that no utilities are below, push the Earth Pin into the ground and connect the black cable to the Earth Pin.

- ☞ For more safety, we recommend pushing the Earth pin into the ground at an angle of 45 degrees.
- ☞ For best performance, position the Earth pin and black cable at 90 degrees to the suspect direction of the utility.



3. Wrap the red cable around the utility.
  -  Never connect the red cable directly to an electrical cable!
  -  To increase performance, increase the amount of wraps.

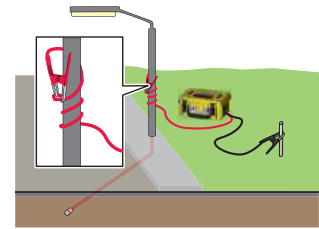

14353\_001

4. Turn on the transmitter.
  -  Ensure that the Connection Mode LED indicator is on and the battery level of the transmitter is adequate.

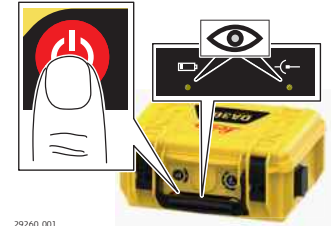

29260\_001

5. Select the required power output level and set the frequency output to 131 kHz.
 

To indicate that the tracing signal reaches a good level, the Power Output LED indicator and the audible tone change from pulsed to continuous.

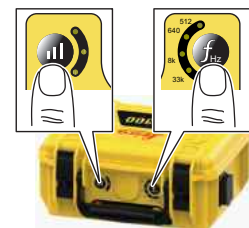

29254\_001

6. Set the locator to Signal Transmitter mode and select the required frequency.
 





29259\_001

7. At a distance of 5 m (16 ft) to the connection point, circle around the connection point.
 



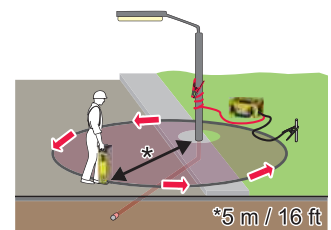

14354\_001



8. In the presence of a detectable utility, the locator emits a tone and the signal strength indicators rise and fall as you pass over the utility. Return to the position where the Locate screen shows a peak reading. Mark the position of a utility with marker paint, pegs, flags or something similar.

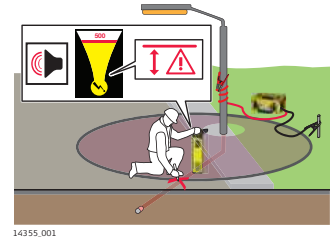

- ☞ Never drive pegs into the ground over the utility!
- ☞ To trace a specific utility, use the pinpointing and tracing methods. Refer to [5.1 How to Pinpoint a Utility](#) and [5.2 How to Trace a Utility](#).

- ☞ Pinpoint and trace utilities until you are satisfied that the area has been adequately tested.

#### 5.5.4 How to use Digital Trim

#### 5.6 How to Use the Trace Rod

##### 5.6.1 General Information

##### Description

The Trace Rod is a utility tracer enabling small diameter non-conductive pipes, ducts, conduit or drains to be traced. It can be used in Line mode to find the route of the duct or Sonde mode to find a blockage.

##### Description of components

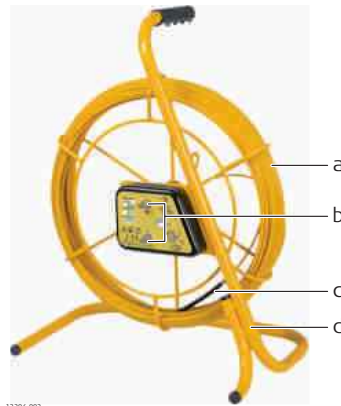

- a **Sonde** – Using Sonde mode, the sonde helps to pinpoint the end point of the trace rod.
- b **Line** – Flexible, glass-fibre sheathed rod, which incorporates copper wires to conduct the signal. Using Line mode, the rod helps to trace the route of a utility.
- c **Connection terminals** – Used to connect to the signal transmitter.
- d **Frame** – Houses the flexible rod. Can be used in both vertical (as in illustration) and horizontal orientation.

##### 5.6.2 Locating a Utility Using the Trace Rod

##### Using the trace rod in Line mode

1. Insert the rod into the pipe until the desired length is in place.

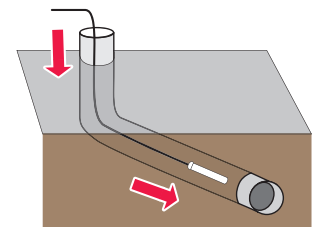

2. Plug the transmitters cable set into the connection socket.



14341.001

3. Ensuring that no utilities are below, push the Earth Pin into the ground and connect the black cable to the Earth Pin.



For more safety, we recommend pushing the Earth pin into the ground at an angle of 45 degrees.



For best performance, position the Earth pin and black cable at 90 degrees to the suspect direction of the utility.

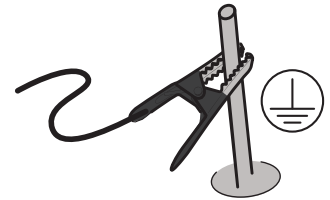

14343.002

4. Connect the red cable to the positive (+) terminal on the trace rod.

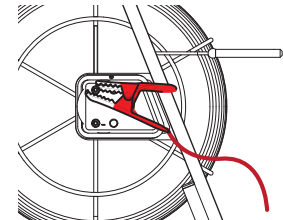

14537.001

5. Turn on the transmitter.



Ensure that the Connection Mode LED indicator is on and the battery level of the transmitter is adequate.

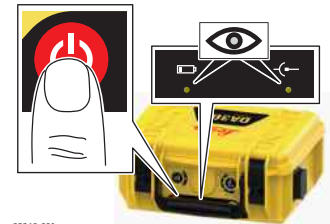

29260.001

6. Select the required frequency and power output.

To indicate that the tracing signal reaches a good level, the Power Output LED indicator and the audible tone change from pulsed to continuous.

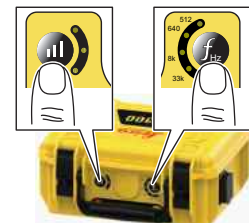

29254.001

7. Set the locator to Signal Transmitter mode and select the required frequency.



29259.001

8. Sweep the area until a signal is detected. Pinpoint and trace the utility.

Use the Numeric Peak Indicator to identify the exact position of the rod. The position is typically indicated by the maximum value.

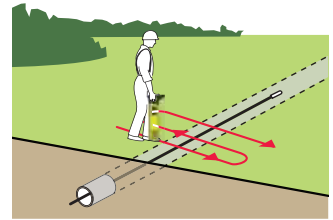

14538.001

### Using the trace rod in Sonde mode

- For ease of use practice the process above ground.
- For ease and convenience mark the ground every 3 to 4 metres.

1. Insert the rod into the pipe, duct or conduit until the desired length is in place.

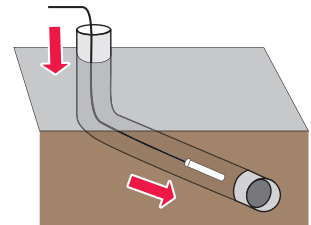

14356.001

2. Plug the transmitters cable set into the connection socket.



14341.001

3. Connect the red cable to the positive (+) terminal on the trace rod. Connect the black cable to the negative (-) terminal.

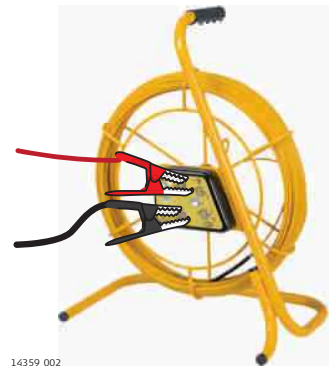

14359.002

4. Turn on the transmitter.

Ensure that the Connection Mode LED indicator is on and the battery level of the transmitter is adequate.

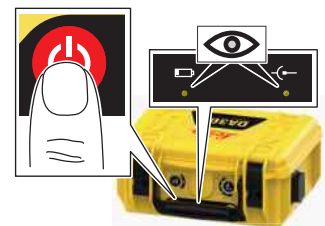

29260.001

- Select the required frequency and power output.  
To indicate that the tracing signal reaches a good level, the Power Output LED indicator and the audible tone change from pulsed to continuous.

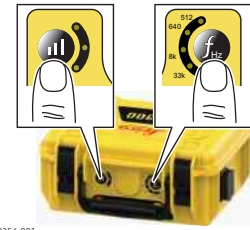

- Set the locator to Sonde mode and select the required frequency.



- Walk in line with the suspected direction of travel observing the display. The signal strength indicator rises and falls as you pass over the ghost signal at the back of the sonde, the peak signal directly over the sonde and the ghost signal at the front. The Numeric Peak Indicator displays its highest value when detecting the peak signal.

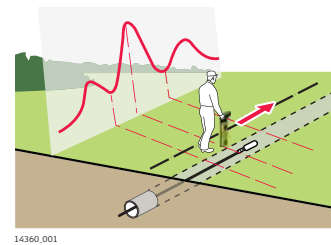

- Retrace your steps and position the locator directly over the peak signal. Move the locator left and right until the highest numeric reading is obtained. This reading indicates the precise location of the sonde. Pinpoint and trace the utility.

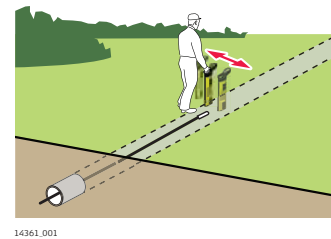

## 5.7

## How to Use the Transmitter Clamps

### 5.7.1

### General Information

#### Description

A Transmitter Clamp provides a safe technique of applying a signal to utilities such as telecom cables, electric cables, etc. It is connected to the Transmitter and then clipped around the utility. Supply is not interrupted by the applied signal.

#### Description of components



- a Transmitter plug connector
- b Jaws
- c Handle
- d Cable

## 5.7.2

## Using a Transmitter Clamp to connect to Cable Utilities

### Connecting to a cable utility

1. Connect the plug of the transmitter clamp to the transmitter.



2. Open the jaws of the transmitter clamp and place it around the utility to be traced.

☞ Ensure that the jaws are fully engaged.

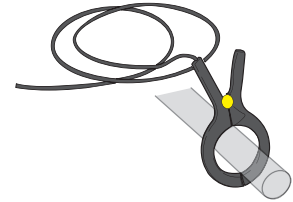

3. Turn on the transmitter.

☞ Ensure that the battery level of the transmitter is adequate.

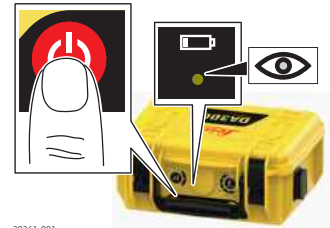

4. Select the required frequency and power output.

☞ For compatible frequencies check the type plate of the transmitter clamp.

To indicate that the tracing signal reaches a good level, the Power Output LED indicator and the audible tone change from pulsed to continuous.

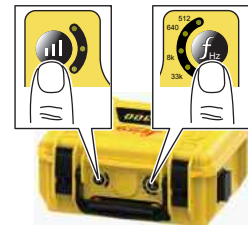

5. Set the locator to Signal Transmitter mode and select the required frequency.



6. Trace the route of the utility. Refer to [5.2 How to Trace a Utility](#).

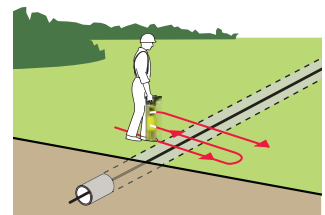

## 5.8 How to Use the Property Plug Connector

### 5.8.1 General Information

#### Description

The Property Plug Connector provides a safe technique of applying a traceable signal to live electricity cables. The applied signal does not interrupt mains supply and the risk of serious injury is greatly reduced.

#### Description of components

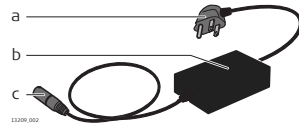

- a Mains plug connector
- b In-line isolator
- c Transmitter plug connector

### 5.8.2 Locating a Utility Using the Property Plug Connector

#### Using the property plug connector

1. Connect the property plug connector to the transmitter.



14342\_001

2. Connect the property plug connector to a live mains outlet.



Ensure that the mains connection is switched on and live.

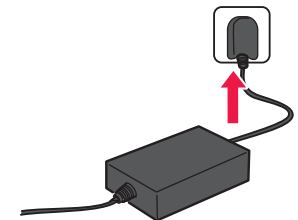

14440\_001

3. Turn on the transmitter.



Ensure that the battery level of the transmitter is adequate.

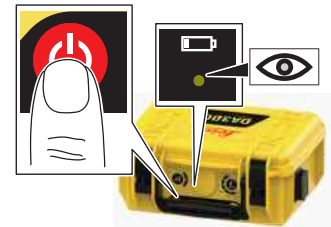

29261\_001

4. Select the required frequency and power output.



Ensure that the frequency output of the transmitter is comparable to that of the property plug connector. Check the type plate of the property plug connector for the frequency rating.



29254\_001

To indicate that the tracing signal reaches a good level, the Power Output LED indicator and the audible tone change from pulsed to continuous.

- Set the locator to Signal Transmitter mode and select the required frequency.



- Trace the length of the utility. Refer to [5.2 How to Trace a Utility](#).

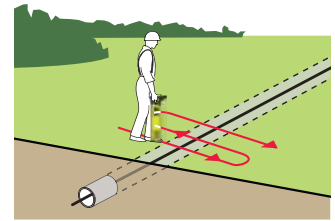

## 5.9 How to Use the Sondes

### 5.9.1 General Information

#### Description

The sondes are signal transmitters used to trace pipes, ducts, conduit or drains. A sonde can be attached to a range of equipment including drain rods, boring tools and inspection cameras. It is powered by its own battery supply, so unlike other accessories this does not require a connection to the transmitter.

The signal pattern transmitted from a sonde is different to that which is radiated from a utility and requires tracing in its own unique method. The sonde transmits a peak signal over its main body, with a ghost signal at its front and back.

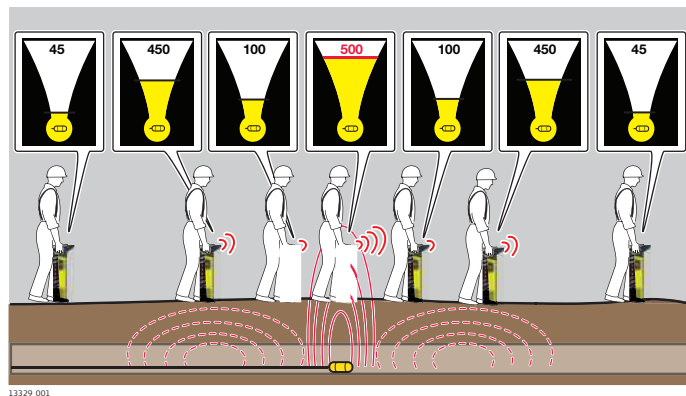

The Locator features a Numeric Peak Indicator which is used to identify the peak reading. Refer to [3.4.2 The Locate Screen](#).

#### How to trace a utility using a sonde



For ease of use practice the process above ground.



For ease and convenience mark the ground every 3 to 4 metres.

1. Set the locator and sonde to the same frequency and verify their performance.



2.  Once the function of the sonde has been verified, connect it to drain rods or other means of guiding it.  
Insert the sonde into the pipe, duct, conduit or drain.

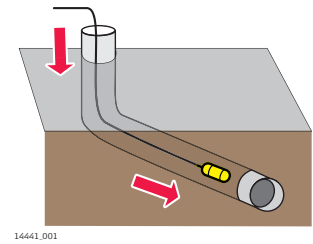

3. Walk in line with the suspected direction of travel observing the display. The signal strength indicator rises and falls as you pass over the ghost signal at the back of the sonde, the peak signal over the sonde and the ghost signal at the front. The Numeric Peak Indicator displays its highest value when detecting the peak signal.

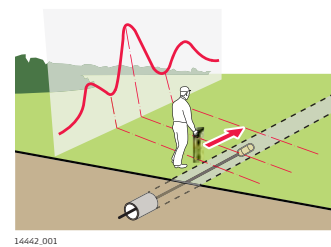

4. Retrace your steps and position the locator directly over the peak signal. Move the locator left and right until the highest numeric reading is obtained. This reading indicates the location of the sonde.

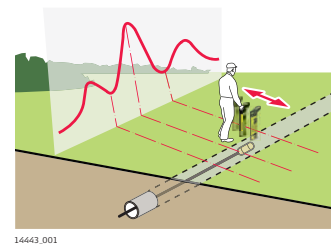



# 6

## Estimating Depth and Current of a Utility

### 6.1

### Utility Line Depth

#### Taking a depth reading

For utility line depth, the locator needs to be used in conjunction with a signal transmitter. Refer to [5.4 Using the Transmitter in Induction Mode](#) and [5.5 Using the Transmitter in Connection Mode](#).

1. Set the locator to Transmitter mode and select the required frequency.

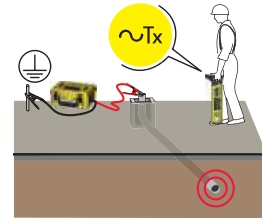

2. Position the locator directly over and at 90° to the direction of the utility.

- Ensure that the locator foot is directly on the ground.
- Hold the locator upright and take care not to move it.

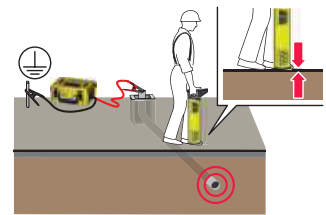

3. Press and release the Depth Estimation key.

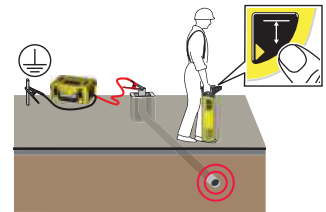

4. The Line Depth screen displays the measured depth.  
*Model-specific option: The measured current (mA) is displayed below the measured depth.*

- Lift the locator off the ground by approximately 15 cm/6 in and take a second depth reading. This depth reading should confirm the added height.

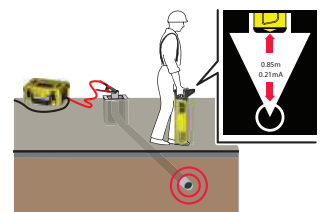

5. The depth is calculated as distance to the centre of the utility! Allowances should be taken into account.  
**Note the difference between a and b!**
  - a) Actual depth of the utility.
  - b) Displayed depth reading: Depth to the centre of the utility.

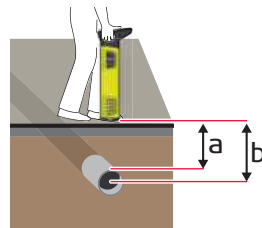

## 6.2

## Sonde Depth

### Taking a depth reading

☞ For sonde depth, the locator needs to be used in conjunction with a sonde. Refer to [5.4 Using the Transmitter in Induction Mode](#).

1. Set the locator to Sonde mode and select the required frequency.



2. Position the locator directly over and in line with the sonde.

- ☞ Ensure that the locator foot is directly on the ground.
- ☞ Hold the locator upright and take care not to move it.

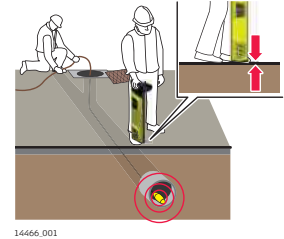

3. Press and release the Depth Estimation key.

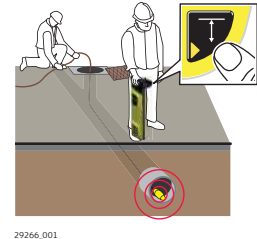

4. The Sonde Depth screen displays the measured depth.

- ☞ Lift the locator off the ground by approximately 15 cm/6 in and take a second depth reading. This depth reading should confirm the added height.

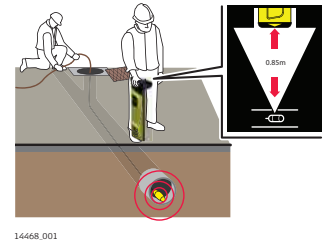

5. The depth is calculated as distance to the sonde within the pipe or duct! Take into account allowances for the diameter of the pipe or duct.

- Note the difference between a and b!**
- a) Actual depth of the utility.
  - b) Displayed depth reading: Depth to the sonde.

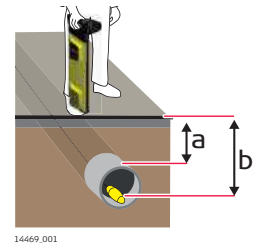

## 6.3

## Depth Code Information

### Depth Code Screens

☞ If it is not possible to take a depth reading, a depth code screen is displayed. Refer to [3.4.3 The Depth Estimation Screens: Depth out of range](#) and [Signal out of range](#).

## 6.4

## Utility Current Measurement

### Current measurement to identify utilities

- ☞ Model-specific option.
- ☞ The Current measurement is measured in mA (milliampere) and is displayed with the utility line depth. Refer to [6.1 Utility Line Depth](#).

### Identifying a utility

The signal transmitter is used to apply a signal (current) to the utility to be traced. The signal can couple onto additional utilities making it difficult to distinguish by conventional locating techniques.

Current measurement helps to identify the utility to which the transmitter is attached by providing the highest current reading (mA). Unlike the Numeric Peak reading, the current reading is not effected by changing depth levels.

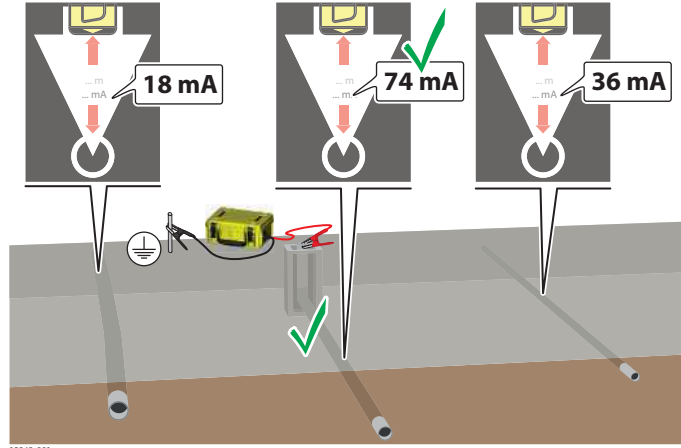

### Identifying the utility layout and condition

The signal (current) applied by the transmitter decreases at a uniform rate as it travels along the utility. This can help to identify the utility layout and condition.

A sudden reduction in current may indicate a fault in the utility, a damage to the insulation, or a connection off the utility.

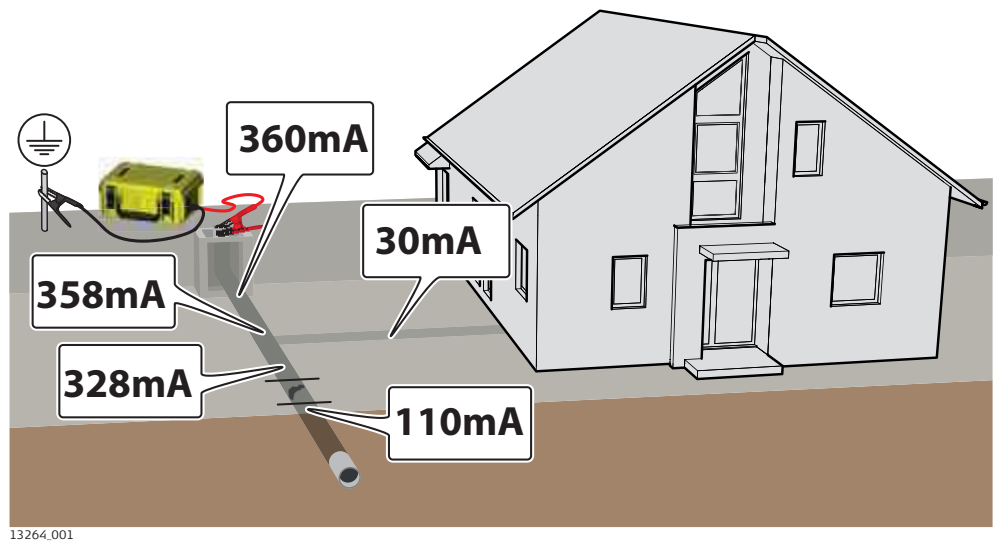

### Connecting the locator using Bluetooth

*Model-specific option:*







The locator is provided with Bluetooth connectivity.

#### Bluetooth status

The Bluetooth status is indicated on the status bar of the Locate screen. Refer to [Status bar icons](#) (within [3.4.2 The Locate Screen](#)).

Colour of Bluetooth Icon	Status
White	Connection available
Green	Connection available and active
Red	Fault

#### Important information for pairing:

-  The locator must be turned on and have the Bluetooth enabled throughout the pairing process.
-  The locator identification is model type and serial number, for example DD300 SMART – 000001
-  For guidance on establishing a connection, follow the instructions on the external device or software. Refer to the manufacturer's instructions.
-  When paired and following a depth reading, the locator will display a Bluetooth symbol within the depth screen. To transfer the information to the data logger press the depth button whilst the Bluetooth symbol is displayed.
-  Whilst the locator is calculating depth the data output stops.
-  If there is no wireless communication then the Bluetooth symbol will not be displayed and the unit will function as a locator.
-  The output format is ASCII.

### Output options

In the submenu **Communication**, select the required Bluetooth option. Refer to [Submenu Communication](#) (within [3.5.2 Menu Options](#)).

#### Output strings

- **DD SMART:**  
DPxxxxUMxMDxUTxMAxxxxxNPxxxPIxxDVxxxSNxxxxxxBTxCMxx DTxxxxxxxx  
DP0.75UMMMD3UTLMA10.20NP450PIODV230SN123456B-  
T9CM12DT01/01/17
- **BT1** option:  
DVxxxSNxxxxxxSVxxxxTMxxxxxDTdd/mm/yyCMxxSTxBTxMDxSSxxUMxDPxxxx  
DV550SN12345SV3.01TM08:30DT01/12/10CM12ST0BT7MD3SS16UMMD-  
P125
- **BT2** option:  
DPxxxxUMxMDxSSxxDVxxxSNxxxxxxCMxxBTxSTxSVxxxxDTxxxxxxxxTMxxxx  
DP125UMMMD3SS16DV550SN12345CM12BT7ST0SV3.01DT01/12/10T-  
M08:30

Data Output	Range	Example Value	Description
DV	000 to 999	230	Model identifier
SN	000000 to 999999	123456	Serial number
SV	0.00 to 9.99	3.01	Software version
TM	00:00 to 23:59	08:30	Time hh:mm Default = 00:00; no RTC fitted
DT	00/00/00 to 31/12/99	01/12/10	Date dd/mm/yy
CM	00 to 12	12	Number of months until next calibration (00 to 12)
ST	0 or 1	0	Health test: 0 = Passed 1 = Fail
BT	0 to 9	7	Battery level: 0 = Empty 9 = Fully charged
MD	0 to A	3	Mode: 0 = Power 1 = Radio 2 = Passive Auto 3 = Transmitter Auto 4 = 33 kHz & 131 kHz 5 = 131 kHz 6 = 33 kHz 7 = 8 kHz 8 = 640 Hz 9 = 512 Hz A = 83 kHz
SS	00 to 75	16	Signal strength: 00 to 75
UM	M or I	M	Units of measurement: Metric or Decimal Feet
DP	0.10 to 9.99 Model dependent	1.25	Depth value displayed depends on value for UM.
UT	L or S	L	Utility type: Line or Sonde
MA	0 to 99.99	1.10	Current measurement displayed in mA
NP	0 to 999	450	Numeric Peak value displayed on the locator
PI	1 to 9	1	Point of Interest: number defines colour of selected marker. x = off

## 7.2

### Locator USB Connectivity

#### Connecting the locator using USB

The locator is provided with a micro USB port and can be connected to a PC for one of the following reasons:

- To update software.
- To provide calibration and maintenance support.
- To configure the product.
- To upload data to the PC (if the locator is provided with memory function).

 It is recommended that a battery level of greater than 50% is maintained whilst in communication with external devices.

#### USB status

The USB status is indicated on the status bar of the Locate screen. Refer to [Status bar icons](#) (within [3.4.2 The Locate Screen](#)).

Colour of USB Icon	Status
White	Connection available
Green	Connection available and active
Red	Fault

#### Access to the USB port

 To maintain environmental protection open and use the USB port only in dry conditions. Always reinstate the cover after use.

1. Unscrew the fastening screws of the cover and open it.

 For guidance on establishing a connection, follow the instructions on the external device or software. Refer to the manufacturer's instructions.

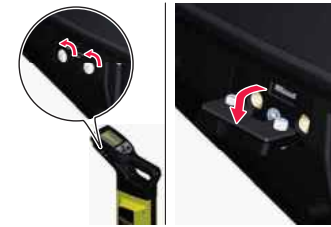

14470.001

2. After disconnection, reinsert the cover and tighten the fastening screws.



14471.001

## 7.3

### Transmitter USB Connectivity

#### Connecting the transmitter using USB

The signal transmitter is provided with a USB port and can be connected to a PC for one of the following reasons:

- To update software.
- To provide calibration and maintenance support.

 It is recommended that a battery level of greater than 50% is maintained whilst in communication with external devices.

## Access to the USB port

---

- ☞ The cover of the battery compartment also serves as cover for the USB port. To maintain environmental protection open the cover only in dry conditions. Always close the cover of the battery compartment after use.
- 

1. Unscrew the fastener of the cover.



29267.001

2. Lift the cover of the battery compartment to access the USB port.

- ☞ For guidance on establishing a connection, follow the instructions on the external device or software. Refer to the manufacturer's instructions.



29271.001

3. After disconnection, close the cover of the battery compartment and tighten the fastener.



29272.001

## 8 Locator Memory and GPS

### 8.1 Internal Memory

#### Record and store information with the locator



The internal memory is a model-specific option.

The internal memory allows you to record and store information while using the locator. After completing the initial start-up routine, information is recorded every second. These records (logs) are stored in the internal memory and can be retrieved and transferred through Bluetooth or USB connection for analysis.



The records are sequentially stored. Once the internal memory is full, the oldest records are overwritten.



To transfer records from the worksite, use the transfer app and Bluetooth connectivity.



Refer to the Leica Geosystems website for the latest information on mobile Apps and analysis software.

### 8.2 Internal GPS

#### Record the geographical position of the locator



The internal GPS module is a model-specific option.

The internal GPS module allows you to record the geographical position while using the locator. The geographical position (Latitude and Longitude) is stored in the internal memory and provides information on where the locator was used.

#### GPS status

The GPS status is indicated on the status bar of the Locate screen. Refer to [Status bar icons](#) (within [3.4.2 The Locate Screen](#)).

Colour of GPS Icon	Status
White	Connection available
Green	Connection available and GPS position found
Red	Fault



As part of the start-up routine, a GPS search mode is activated allowing the internal GPS module time to search for the GPS position. The Search mode is active during the power up cycle of the locator. Once a GPS position is found, the locator will retain the GPS Fix for 6 minutes after the locator is powered down.



The GPS search mode does not affect the performance of the locator. The locator can be used as normal while the search mode is active.

### 8.3 Point of Interest

#### Record a point of interest





This function requires a locator model with internal GPS module and internal memory.

Locators with an internal GPS module allow you to record a Point of Interest (POI) and store it in the internal memory. Use the Point-of-Interest function to highlight worksite features of particular interest, such as the position of a utility or the location of an access chamber.



 The Point-of-Interest function can be used in all search modes.

1. Select  from the main menu.
2. Select  to adjust the Point-of-Interest setting.
3.
  - Select a marker in the desired colour to activate the POI function.  
The activated POI status is indicated on the status bar of the Locate screen. Refer to [Status bar icons](#) (within [3.4.2 The Locate Screen](#)).
  - Select  to turn off the POI function.
4. To record a Point of Interest, press and release the Depth Estimation key.



 When a GPS position is available, the POI information is recorded and stored in the internal memory.

### Available POI markers

Depending on the colour, the following numbers are recorded to the internal memory:

Blue	Brown	Green	Grey	Orange	Purple	Red	White	Yellow
1	2	3	4	5	6	7	8	9

## 9

## Power Supply



Use the locators and transmitters with Alkaline batteries or with an optional available authorised rechargeable Li-Ion battery pack.

### 9.1

### Alkaline Batteries

#### Changing the batteries

The DA300 Transmitter is fitted with four LR20 (D) alkaline batteries.



1. Unscrew the fastener and open the cover.
2. Replace all batteries with four new LR20 (D) type Alkaline batteries.

### 9.2

### Li-Ion Battery

#### **WARNING**

#### **Short circuit of battery terminals**

If battery terminals are short circuited e.g. by coming in contact with jewellery, keys, metallised paper or other metals, the battery can overheat and cause injury or fire, for example by storing or transporting in pockets.

#### **Precautions:**

- ▶ Make sure that the battery terminals do not come into contact with metallic/conductive objects.

## 9.2.1

## Operating Principles

### First-time use/ charging batteries

- The battery must be charged before using it the first time, because it is delivered with an energy content as low as possible or might be in sleep mode.
- The permissible temperature range for charging is from 0 °C to +40 °C/ +32 °F to +104 °F. For optimal charging, we recommend charging the batteries at a low ambient temperature of +10 °C to +20 °C/+50 °F to +68 °F if possible
- It is normal for the battery to become warm during charging. Using the chargers recommended by Leica Geosystems, it is not possible to charge the battery once the temperature is too high
- For new batteries or batteries that have been stored for a long time (> three months), it is effectual to make a discharge/charge cycle
- For Li-Ion batteries, a single discharge/charge cycle is sufficient. We recommend carrying out the process when the battery capacity indicated on the charger or on a Leica Geosystems product deviates significantly from the actual battery capacity available.

### Operation/discharging

- The batteries can be operated from -20 °C to +55 °C/-4 °F to +131 °F
- Low operating temperatures reduce the capacity that can be drawn; high operating temperatures reduce the service life of the battery

### 9.2.1.1

### Charging the Li-Ion Battery Pack

#### **WARNING**

#### **Short circuit of battery terminals**

If battery terminals are short circuited e.g. by coming in contact with jewellery, keys, metallised paper or other metals, the battery can overheat and cause injury or fire, for example by storing or transporting in pockets.

#### **Precautions:**

- ▶ Make sure that the battery terminals do not come into contact with metallic/conductive objects.

### Charging the battery pack of the locator



If the batteries of the locator are low and need to be recharged, the status bar icon for the battery condition changes to red.

1. Rotate and disengage the clips of the battery compartment.



14481.001

2. Lift the cover of the battery compartment and remove the Li-Ion battery pack.



14483.001

3. Connect the charger plug into the charge jack on the battery pack.



14679\_001

4. Plug the connector into a suitable power source.



The small LED next to the charge jack flashes to indicate that the battery pack is charging. When the battery pack is fully charged the LED is on solid.

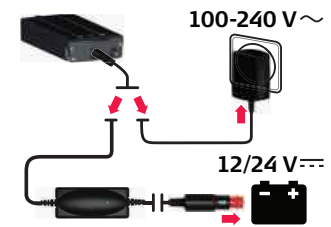

14680\_001

5. When the battery pack is fully charged, disconnect the charger and reinsert the battery pack into the battery compartment.



14684\_001

6. Close the battery compartment and secure the clips.



14682\_001

## Charging the battery pack of the signal transmitter



If the battery pack of the signal transmitter is low and needs to be recharged, the Low Battery LED indicator illuminates red.



The cover of the battery compartment also serves as cover for the USB port. To maintain environmental protection open the cover only in dry conditions. Always close the cover of the battery compartment after use.

1. Unscrew the fastener of the battery cover.



14672\_001

2. Lift the cover of the battery compartment and remove the Li-Ion battery pack.

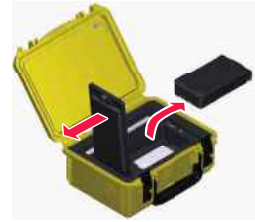

14475.001

3. Connect the charger plug into the charge jack on the battery pack.



14479.001

4. Plug the connector into a suitable power source.



The small LED next to the charge jack flashes to indicate that the battery pack is charging. When the battery pack is fully charged the LED is on solid.

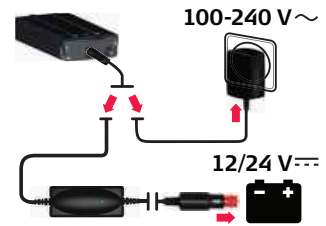

14480.001

5. When the battery pack is fully charged, disconnect the charger and reinsert the battery pack into the battery compartment.



14476.001

6. Close the cover of the battery compartment and tighten the fastener.



14473.001

## 10

## Functional Checks

### 10.1

### Locator Health Check

#### Checking the function







Leica Geosystems accepts no responsibility for maintenance and calibration conducted by unauthorised persons. It is vital to check the status of the unit, its basic functionality and batteries before Calibration Verification is used.

1. **Inspect the general condition of the locator.**
  - The casing should be free of significant damage and maintain the products environmental rating against water and dust ingress.
  - Switches and control devices must be free of defect.
  - Labels must be legible and intact, any display or membrane label must be free of damage and tears.
  - The cover of the battery compartment must lock into place.
  - All the battery contacts and springs of the compartment must be free of corrosion and the compartment in good condition.
  - The batteries must be charged in excess of 50%.
  - The cover of the USB port must be in place and provide the required environmental protection against water and dust ingress.
2. **Once the general condition of the locator is established, perform the Audio/Visual test.**

Turn on the locator. The display must illuminate with a splash screen followed by the Locate screen. The locator should emit a tone.

#### Checking the performance

The purpose of the following procedure is to verify the performance of the locator.

-  Conduct the test away from areas of electromagnetic interference or over buried utilities with a large signal radiating off them.
1. Turn on the locator.
  2. Press and hold the Menu key to display the Locator main menu.
    -  Navigate to option **Health Check** .
  3. Press and release the Menu key to perform a Health Check.
  4. Observe the displayed output.
    -  The locator is within the set tolerances.
    -  The locator is outside the set tolerances and may need servicing.
    -  The electrical noise level is too high to start the test. Repeat the test in a different location.
-  If the Health Check fails, the locator automatically repeats it. Repeated failure indicates a faulty unit. Return the locator for service.

#### Locator depth test

-  To carry out this test, the depth of the test utility must be known.
1. Connect and apply a traceable signal to the test utility. Refer to [5.5.2 Direct Connection Mode](#).
  2. Turn on the locator and perform a depth reading. Refer to [6.1 Utility Line Depth](#).



If the depth reading deviates from known depth of the test utility or if an error code is displayed, return the locator for service.

---

## 10.2

### Calibration Verification

---

#### Purpose of calibration verification

Calibration Verification provides an over the internet verification of key circuit components and calibration settings. The current status is verified against settings established during original manufacture test and calibration.

Upon a successful verification, a Calibration Certificate is provided and the products calibration maintenance dates are updated, units outside of tolerance should be returned to an approved service centre.

---

#### Checking the function

Leica Geosystems accepts no responsibility for maintenance and calibration conducted by unauthorised persons. It is vital to check the status of the unit, its basic functionality and batteries before Calibration Verification is used.

---

1. **Inspect the general condition of the locator.**

- The casing should be free of significant damage and maintain the products environmental rating against water and dust ingress.
  - Switches and control devices must be free of defect.
  - Labels must be legible and intact, any display or membrane label must be free of damage and tears.
  - The cover of the battery compartment must lock into place.
  - All the battery contacts and springs of the compartment must be free of corrosion and the compartment in good condition.
  - Default battery source is alkaline. Battery level must be above 50%.
  - The cover of the USB port must be in place and provide the required environmental protection against water and dust ingress.
- 

2. **Once the general condition of the locator is established, perform the Audio/Visual test.**

Turn on the locator. The display must illuminate with a splash screen followed by the Locate screen. The locator should emit a tone.

---

#### Activating calibration verification

DX Office Shield software is used to purchase and activate Calibration Verification. It is important that this is installed on a PC with Internet access. For additional information refer to <https://leica-geosystems.com>.

---

1. Connect to DX Office Shield via USB. Refer to [7.2 Locator USB Connectivity](#) and [7.3 Transmitter USB Connectivity](#).



2. Purchase and activate Calibration Verification from the CalMaster tab. A user login will be required. Full instructions are provided in DX Office Shield.

3. After testing remove USB Cables and secure the USB cover in place.



## Checking the performance

The purpose of the following procedure is to verify the performance of the locator.

- ☞ Conduct the test away from areas of electromagnetic interference or over buried utilities with a large signal radiating off them.

1. Turn on the locator.
2. Press and hold the Menu key to display the Locator main menu. Navigate to the **Health Check** icon
3. Press and release the Menu key to activate the **Health Check**.
4. Observe the displayed output.
  - ✓ The locator is within the set tolerances.
  - ✗ The locator is outside the set tolerances and may need servicing.
  - ⊘ The electrical noise level is too high to start the test. Repeat the test in a different location.

- ☞ If the **Health Check** fails, the locator automatically repeats it. Repeated failure indicates a faulty unit. Return the locator for service.



## 10.3

## Locator Fault Codes

### Fault codes and troubleshooting

If the locator detects a fault, a notification is displayed on the startup screen or within the status bar.

To display the locators fault code, access the Alerts menu and select this option: .

Refer to [Submenu Alerts](#) within [3.5.2 Menu Options](#).

Fault Code	Fault Area	Explanation and Recommended Action
F00	Product test	<ul style="list-style-type: none"><li>• Activate the product test away from potential sources of electrical interference. For product testing, refer to <a href="#">10.1 Locator Health Check</a>.</li><li>• If fault persists, return to service partner.</li></ul>
F20	Communication	Fault with external communications such as Bluetooth, GPS or USB connection. <ul style="list-style-type: none"><li>• Refer to <a href="#">7 Connectivity</a>.</li><li>• If fault persists, return to service partner.</li></ul>
F40	Hardware Fault	Fault with electronic hardware, e.g. memory, motion sensor or time clock. If fault persists, return to service partner.
F56	Trigger Fault	Fault with Trigger Button, Return to Service partner for diagnosis and repair.
F60	Aerial Fault	Return to service partner for diagnosis and repair.

## 10.4

## Transmitter Functional Check

### Checking the function

Before you carry out any tests, it is vital to check the status of the unit, its batteries and its basic functionality. To achieve this, carry out the following procedure:



For this procedure, the cable set of the transmitter and a fully charged battery pack are required.

1. **Inspect the general condition of the transmitter.**
  - The casing should be free of significant damage.
  - The cable set should be free of damage to the cable insulation and clip shrouds. The clips should be free of corrosion.
  - Body labels must be legible and intact.
  - The cover of the battery compartment must lock into place.
  - All the battery contacts and springs of the compartment must be free of corrosion and the compartment in good condition.
  - The battery contacts must be free of corrosion.
  - The cover of the USB port must be in place and provide the required environmental protection.

2. **Once the general condition of the transmitter is established, perform the Audio/Visual test.**  
Turn on the transmitter. All LED indicators should light up and the speaker should emit a tone.

---

3. **Perform a Battery check - only in presence of Li-Ion Battery Pack .**  
Observe the Low Battery LED indicator and replace or recharge the batteries if necessary.

---

## Checking the performance

The purpose of the following procedure is to verify the performance of the transmitter.

-  Conduct the test away from areas of electromagnetic interference or over buried utilities with a large signal radiating off them.

---

  1. Plug the transmitters cable set into the connection socket.

---

  2. Connect the black and red cable clips together, ensuring good metal to metal contact.

---

  3. Press and hold the Frequency key and turn on the transmitter. Keep holding the Frequency key until the test starts.

---

  4. Observe the displayed output during the performance check:
    - Induction Mode Test:** The Frequency LED indicators light up one after the other, showing the frequency on test.
    - Connection Mode Test:** The Connection Mode LED indicator lights up. The Frequency LED indicators light up, showing the frequencies on test. The Connection Mode LED indicator turns off.

---

  5. After the performance check, the transmitter displays the result:
    - Test successful:** A high-low pulsed tone is emitted three times. If the test was done with low batteries, the Low Battery LED indicator illuminates.
    - Test failed:** A low-pitched tone is emitted. If the test was done with low batteries, the Low Battery LED indicator illuminates.
      - If the Induction Mode failed: The respective Frequency LED indicator lights up.
      - If the Connection Mode failed: The Connection Mode LED indicator and the respective Frequency LED indicator light up.

---

  -  If the performance check fails, ensure that the cable set of the transmitter is fully engaged and the clips are connected.

---

  -  If the performance check fails, the transmitter automatically repeats it. Repeated failure indicates a faulty unit. Return the transmitter for service.

---

  -  The Signal Transmitters firmware can be updated to the latest standard using DX Office Shield. It is important that DX Office Shield is installed on a PC with Internet access.  
For additional information refer to <https://leica-geosystems.com>.

---

## 10.5

### Functional Check of the Trace Rod

#### Checking the performance

The purpose of the following procedure is to verify the performance of the trace rod.



For this procedure, the following system components are required:

- A transmitter for generating the signal in the Sonde and Line mode tests.
- The cable set for the transmitter.

1. Plug the transmitters cable set into the connection socket.
2. Connect the red cable to the positive (+) terminal on the trace rod and the black cable to the negative (-) terminal.
3. Turn on the transmitter.
4. Use the Power Output key on the transmitter to adjust the power output to minimum.  
The transmitter should emit a constant tone.
5. Disconnect the black cable from the negative (-) terminal.  
The transmitter should emit a pulsed tone.



If for any of these tests no output or a significantly different output is displayed, return the trace rod for service.

## 10.6

### Functional Check of the Sonde

#### Checking the function

Before you carry out any tests, it is vital to check the status of the unit, its batteries and its basic functionality. To achieve this, carry out the following procedure:

1. **Inspect the general condition of the sonde.**
  - The casing should be free of significant damage.
  - The sealing ring and the screw thread should be intact.
2. **Once the general condition of the sonde is established, perform the LED test.**  
Turn on the sonde. The LED indicator should light up.
3. **Perform a Battery check.**  
If the LED indicator lights up faintly or if the sonde does not transmit a signal, the batteries are probably low. Replace the batteries if necessary.

## Checking the performance

The purpose of the following procedure is to verify the performance of the sonde.

- ☞ For this procedure, the following system components are required:
- A locator to detect the signal of the sonde.
  - A work area free of utilities (as illustrated).

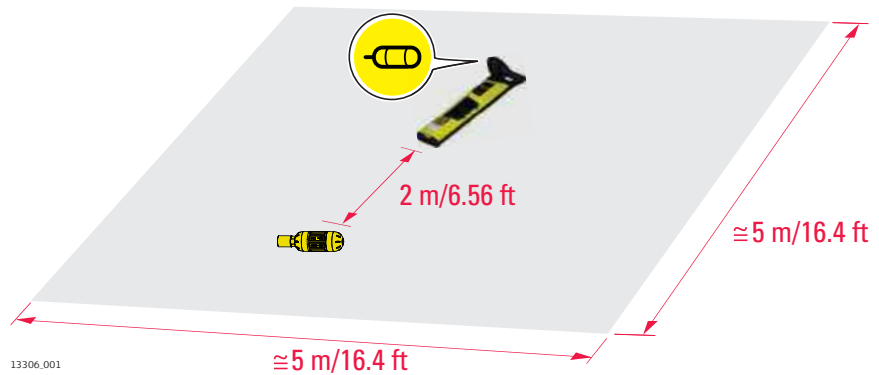

1. Set up the sonde for use at 33 kHz.
  2. Turn on the locator. Set the locator to 33 kHz Sonde mode.
  3. Aim the locator foot at the sonde.  
☞ At a distance of 2 m/6.56 ft, the signal strength indicators should display a peak reading.
  4. Set up the sonde for use at 8 kHz.
  5. Turn on the locator. Set the locator to 8 kHz Sonde mode.
  6. Aim the locator foot at the sonde.  
☞ At a distance of 2 m/6.56 ft, the signal strength indicators should display a peak reading.
- ☞ If for any of these tests no output or a significantly different output is displayed, return the sonde for service.

## 11 Care and Transport

---

### 11.1 Transport

---

<b>Transport in the field</b>	When transporting the equipment in the field, always make sure that you carry the product in its original packaging or equivalent, and protect the equipment against shock and vibration.
<b>Transport in a road vehicle</b>	Never carry the product loose in a road vehicle, as it can be affected by shock and vibration. Always carry the product in its container and secure it.
<b>Products without container</b>	For products for which no container is available use the original packaging or its equivalent.
<b>Shipping</b>	When transporting the product by rail, air or sea, always use the complete original Leica Geosystems packaging, container and cardboard box, or its equivalent, to protect against shock and vibration.
<b>Shipping, transport of batteries</b>	When transporting or shipping batteries, the person responsible for the product must ensure that the applicable national and international rules and regulations are observed. Before transportation or shipping, contact your local passenger or freight transport company.

---

### 11.2 Storage

---

<b>Product</b>	Respect the temperature limits when storing the equipment, particularly in summer if the equipment is inside a vehicle. Refer to <a href="#">12 Technical Data</a> for information about temperature limits.
<b>Storing</b>	Long-term battery storage is not recommended. If storage is necessary: <ul style="list-style-type: none"><li>• Refer to <a href="#">12 Technical Data</a> for information about storage temperature range</li><li>• Remove batteries from the product and the charger before storing</li><li>• After storage recharge batteries before using</li><li>• Protect batteries from damp and wetness. Wet or damp batteries must be dried before storing or use</li><li>• A storage temperature range of 0 °C to +30 °C/+32 °F to +86 °F in a dry environment is recommended to minimise self-discharging of the battery</li><li>• At the recommended storage temperature range, batteries containing a 40% to 50% charge can be stored for up to one year. After this storage period the batteries must be recharged</li><li>• Always try to use a 'first-in first-out' approach to minimise storage time</li></ul>

---

### 11.3 Cleaning and Drying

---

<b>Damp products</b>	Dry the product, the transport container, the foam inserts and the accessories at a temperature not greater than 40 °C/104 °F and clean them. Remove the battery cover and dry the battery compartment. Do not repack until everything is dry. Always close the transport container when using in the field.
----------------------	--

---

## **Cables and plugs**

Keep plugs clean and dry. Blow away any dirt lodged in the plugs of the connecting cables.

---

## 12

## Technical Data

### 12.1

### General Technical Data

#### 12.1.1

#### Transmitter Technical Data

##### DA series signal transmitters

Mode	Output
Induction	Up to 1 Watt max.
Connection mode	Up to 1 Watt, when connected to a buried utility with an impedance of 300 Ohms
Operating transmission frequencies	131.072 (131) kHz 83.078 (83) kHz 32.768 (33) kHz 8.192 (8) kHz 512 Hz 640 Hz
Display panel	LED Indicators: Battery low indicator Connection mode Frequency indicator Power Output indicator
Keypad	4 membrane push buttons
Audio	85 dBA @ 30 cm Induction mode: Pulsed output with a differing rate for each frequency Connection mode: Low - No output: pulsed output, differing rate for each frequency Good Connection output: constant tone, pitch dependent on power output
Battery type	4× LR20 = Alkaline batteries Optional: 7.4 V Li-Ion pack
Typical operating time 3 Watt, 1 Watt	15 hours at power level 2 connection mode
Dimensions	250 × 206 × 113 mm/ 9.84 × 8.11 × 4.45 inches
Weight (incl. standard accessories and batteries)	2.70 kg with Alkaline 2.38 kg with Li-Ion
Temperature	Operating -20°C to +50°C, -4°F to +122°F Storage -40°C to +70°C, -40°F to +158°F
Protection against water, dust and sand	Conforms to IP67 lid open or closed
Humidity	95% RH non condensing The effects of condensation are to be effectively counteracted by periodically drying out the product.
Approvals	CE, FCC

## Dimensions



### 12.1.2

### Locator Technical Data

#### DD300 locators

#### Operating frequencies

Mode	Frequency	Sensitivity @ 1 meter
Power	50 Hz / 60 Hz mains electrical and harmonics	3 mA
Radio	15 kHz to 60 kHz	25 $\mu$ A
Auto	Power, Radio, 33 kHz	Mode dependent
Transmitter	131.072 (131) kHz	5 $\mu$ A
	83.078 (83) kHz	5 $\mu$ A
	32.768 (33) kHz	5 $\mu$ A in
	8.192 (8) kHz	100 $\mu$ A
	512 Hz (DD230 series models)	500 $\mu$ A
	640 Hz (DD230 series models)	500 $\mu$ A

#### Depth estimation

Locator	DD300 series
Depth range	Line 0.1m to 5m
	Sonde 0.1m to 7m
Depth accuracy	5%
Undistorted signal	



## General technical data

Mode	Output
Display panel	Colour LCD
Keypad	3 membrane push buttons
Audio	85 dBA @ 30 cm Power, Radio, Auto Differing Tone for each mode Transmitter Modes Same tone
Battery type	7.4 V Li-Ion pack or 4 ×D Cell LR20, 1.5 V Alkaline batteries
Typical operating time	15 hours constant use at 20 °C/68 °F
Dimensions	93 × 290 × 765 mm/ 3.66 × 11.42 × 30.12 inches
Weight (incl. batteries)	2.9 kg with Alkaline batteries 2.7 kg with Li-ion

## Environmental specifications

### Temperature

Type	Operating temperature	Storage temperature
DD300 series, DA300 series	-20 °C to +50 °C [-4 °F to +122 °F]	-40 °C to +70 °C [-40 °F to +158 °F]

### Protection against water, dust and sand

Type	IP class
DD300 series	IP65 (IEC 60529)
DA300 series	IP67 (IEC 60529)

### Pollution degree

Type	Pollution degree
DD300 series, DA300 series	4 Electrical equipment for outdoor use.

### Humidity

Type	Protection
DD300 series, DA300 series	Max 95% non-condensing. The effects of condensation are to be effectively counteracted by periodically drying out the instrument.

### Altitude

Type	Usage	Range (above sea level)	
		[m]	[ft]
DD300 series, DA300 series	Operation	0 to 5 500	0 to 18 000
	Storage	0 to 12 000	0 to 39 500

## Sound level

Type	Value
DD300 series, DA300 series	< 80 db(A)

## Dimensions

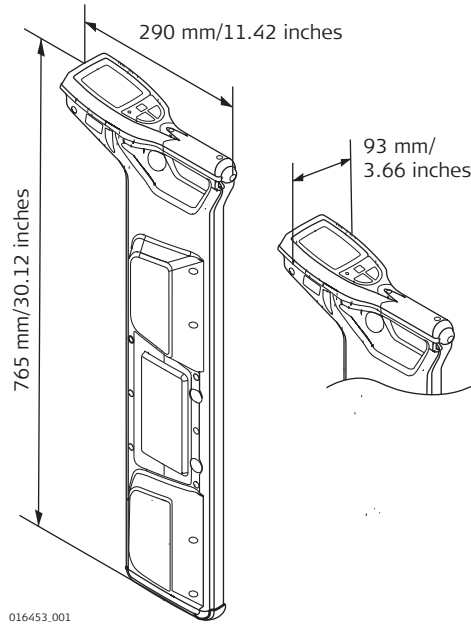

## Smart locators

Component	Value
<b>Bluetooth</b>	Class 2 BLE dual mode module <ul style="list-style-type: none"> <li>Bluetooth Classic 2.1</li> <li>Bluetooth 4.0 (LE)</li> </ul>
<b>Memory</b>	8 GB internal memory
<b>GPS</b>	Chipset <b>(1)</b> : u-blox®GPS <ul style="list-style-type: none"> <li>Receiver Type: GPS L1C/A, SBAS L1C/A, QZSS L1C/A, GLONASS L1OF, BeiDou B1</li> <li>Accuracy <b>(2)</b>: Horizontal Position 2.5 m Autonomous, 2.0 m SBAS, CEP</li> <li>Start time: Cold 45 s typical, Aided 7 s typical, Hot 1 s typical</li> </ul>

**(1)** All data/information according to manufacturer u-blox®GPS; Leica Geosystems does not assume any liability whatsoever for such information.

**(2)** Accuracy is dependent upon various factors including atmospheric conditions, multipath, obstructions, signal geometry and number of tracked satellites.

## Charger

Description	A100 Lithium Ion Charger	A140 Lithium Ion Charger
<b>Type</b>	Li-Ion battery charger	Li-Ion battery charger
<b>Input voltage</b>	100 V AC-240 V AC, 50 Hz-60 Hz	12 V DC

Description	A100 Lithium Ion Charger	A140 Lithium Ion Charger
Output voltage	12 V DC	12 V DC
Output current	3.0 A	5.0 A
Polarity	Shaft: negative, Tip: positive	Shaft: negative, Tip: positive

#### Battery pack

Description	D Series Lithium-Ion Battery pack
Type	Li-Ion battery pack
Input voltage	12 V DC
Input current	2.5 A
Charge time	5 hours (maximum) at 20°C

### 12.1.3

#### Conductive Rod Technical Data

#### Conductive rod

Description	Value
Typical detection range	Both modes, line and sonde: Typical 3.0 m/ 10 ft
Tracing distance	50 m/165 ft; 80 m/263 ft (maximum). Reel length dependant.
Operating transmission frequencies	Dependent on transmitter
Dimensions	440 x 210 x 490 mm/ 17.3 x 8.3 x 19.3 inches
Weight	50 m: 4 kg/8.8 lbs 80 m: 4.7 kg/10.4 lbs

#### Dimensions

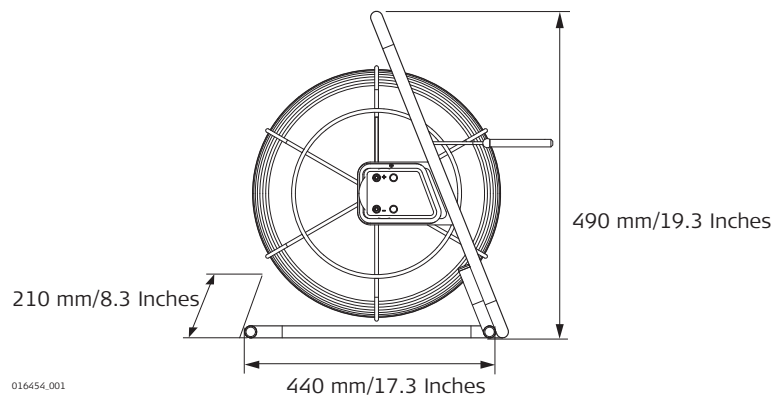

### 12.1.4

#### Property Plug Connector Technical Data

#### Property plug connector

Operating transmission frequencies	32.768 (33) kHz
Temperature	Operating -20 °C to +50 °C -4 °F to +122 °F
	Storage -40 °C to +70 °C -40 °F to +158 °F

**Protection against water, dust and sand**

IP54 (IEC 60529) Dust-protected

**Humidity**

95% RH non condensing  
The effects of condensation are to be effectively counteracted by periodically drying out the product.

**Dimensions**

100 × 80 mm/3.9 × 3.1 inches

**Weight**

0.15 kg/0.3 lbs

## Dimensions

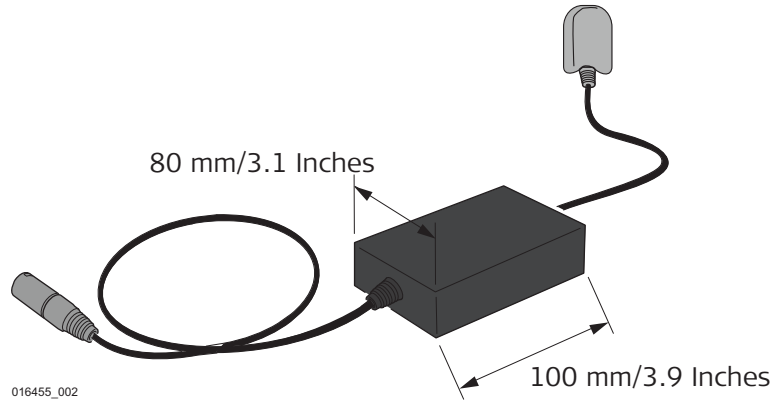

## 12.2

## Conformity to National Regulations

Valid for DA300 Transmitter:

### Labelling DA series transmitters



Leica Geosystems Heinrich-Wild-Strasse CH-9435 Heerbrugg Made in the UK	Power: 4xLR20 (D) Alkaline 6V normal / 2A Max.	   	GB Importer: Leica Geosystems Ltd. Hexagon House, Michigan Drive, Tongwell, Milton Keynes, MK15 8HT
<b>Model:</b>	<b>Art No.:</b>	<b>S.No.:</b>	<b>YYYY</b>
DA300			

FCC ID: UFW-DA300  
IC: 8991A-DA300

This device complies with part 15 of the FCC Rules. Operation is subject to the following two conditions:  
(1) This device may not cause harmful interference, and  
(2) This device must accept any interference received, including interference that may cause undesired operation.

29240.001

## Radio Exposure Statement

In order to comply with RF Exposure requirements, this device must be used/ installed to provide at least 20 cm separation from the human body at all times.

EU



Hereby, Leica Geosystems AG declares that the product/s is/are in compliance with the essential requirements and other relevant provisions of the applicable European Directives. The full text of the EU declaration of conformity is available at the following Internet address:  
<http://www.leica-geosystems.com/ce>.

UKCA



Hereby, Leica Geosystems AG declares that the product/s is/are in compliance with the essential requirements and other relevant provisions of the applicable UK Directives. The full text of the UKCA declaration of conformity is available at the following Internet address:  
<https://leica-geosystems.com>

USA

FCC ID: UFW-DA300  
FCC Part 15, Part 15 B/C

This device complies with part 15 of the FCC Rules. Operation is subject to the following two conditions:

1. This device may not cause harmful interference, and
2. This device must accept any interference received, including interference that may cause undesired operation.

This equipment has been tested and found to comply with the limits for a Class B digital device, pursuant to part 15 of the FCC Rules.

These limits are designed to provide reasonable protection against harmful interference in a residential installation.

This equipment generates, uses, and can radiate radio frequency energy and, if not installed and used in accordance with the instructions, it may cause harmful interference to radio communications.

However, there is no guarantee that interference does not occur in a particular installation.

If this equipment does cause harmful interference to radio or television reception, which can be determined by turning the equipment off and on, the user is encouraged to try to correct the interference by one or more of the following measures:

- Reorient or relocate the receiving antenna.
- Increase the separation between the equipment and the receiver.
- Connect the equipment into an outlet on a circuit different from that to which the receiver is connected.
- Consult the dealer or an experienced radio/TV technician for help.

Changes or modifications not expressly approved by Leica Geosystems for compliance could void the user's authority to operate the equipment.

Canada

CAN ICES-003 B/NMB-003 B  
IC: 8991A-DA300

ICES-003 Class B Notice - Avis NMB-003 Classe B

This Class B digital device complies with Canadian ICES-003.

Cet appareil numérique classe B est conforme à la norme NMB-003 du Canada.

### **Canada Compliance Statement**

This device contains licence-exempt transmitter(s)/receiver(s) that comply with Innovation, Science and Economic Development Canada's licence-exempt RSS(s). Operation is subject to the following two conditions:

1. This device may not cause interference
2. This device must accept any interference, including interference that may cause undesired operation of the device

### **Canada Déclaration de Conformité**

L'émetteur/récepteur exempt de licence contenu dans le présent appareil est conforme aux CNR d'Innovation, Sciences et Développement économique Canada applicables aux appareils radio exempts de licence. L'exploitation est autorisée aux deux conditions suivantes:

1. L'appareil ne doit pas produire de brouillage
2. L'appareil doit accepter tout brouillage radioélectrique subi, même si le brouillage est susceptible d'en compromettre le fonctionnement du dispositif

---

This device and its antenna(s) must not be co-located or operating in conjunction with any other antenna or transmitter except in accordance with ISED multi-transmitter product procedures.

This device complies with Health Canada's Safety Code. The installer of this device should ensure that RF radiation is not emitted in excess of the Health Canada's requirement.

---

Cet appareil et son (ses) antenne(s) ne doivent pas être co-localisés ou utilisés en conjonction avec une autre antenne ou un autre émetteur, sauf en conformité avec les procédures du produit multi-émetteur de la ISED.

Cet appareil est conforme avec Santé Canada Code de sécurité 6. Le programme d'installation de cet appareil doit s'assurer que les rayonnements RF n'est pas émis au-delà de l'exigence de Santé Canada.

---

#### Responsible Party – Canada Contact Information

Company Name: Leica Geosystems Ltd.

CN Number: 3177B

Street Address: 1-3761 Victoria Park Ave

City/Province/Zip: Scarborough, Ontario M1W 3S2, Canada

Telephone No: +1 416 497 2463

Email: dwayne.louviere@leicaus.com

### **Others**

---

The conformity for countries with other national regulations has to be approved prior to use and operation.

---

**Valid for DD300 Locator:**

## Labelling DD300

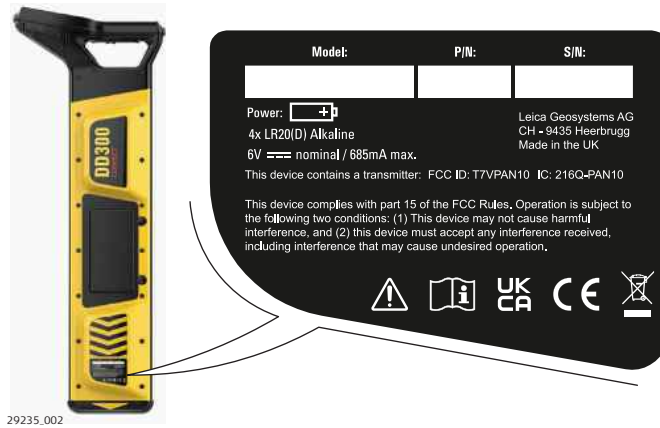

29235\_002

### Radio Exposure Statement

In order to comply with RF Exposure requirements, this device must be used/ installed to provide at least 20 cm separation from the human body at all times.

### EU



Hereby, Leica Geosystems AG declares that the radio equipment type DD300 is in compliance with Directive 2014/53/EU and other applicable European Directives.

The full text of the EU declaration of conformity is available at the following Internet address: <http://www.leica-geosystems.com/ce>.

### UKCA



Hereby, Leica Geosystems AG declares that the radio equipment type DD300 is following the provisions of the applicable relevant statutory requirement UK Directive UK SI 2017 No. 1226 Radio Equipment Regulation 2017. This equipment can be placed on the market and be put into service without restriction in any UK Country.

Licensing requirements in UK can be found here: <https://myworld.leica-geosystems.com>

### USA

Contains FCC ID: T7VPAN10  
FCC Part 15, Part 15 B/C

This device complies with part 15 of the FCC Rules. Operation is subject to the following two conditions:

1. This device may not cause harmful interference, and
2. This device must accept any interference received, including interference that may cause undesired operation.

This equipment has been tested and found to comply with the limits for a Class B digital device, pursuant to part 15 of the FCC Rules.

These limits are designed to provide reasonable protection against harmful interference in a residential installation.

This equipment generates, uses, and can radiate radio frequency energy and, if not installed and used in accordance with the instructions, it may cause harmful interference to radio communications.

However, there is no guarantee that interference does not occur in a particular installation.

If this equipment does cause harmful interference to radio or television reception, which can be determined by turning the equipment off and on, the user is encouraged to try to correct the interference by one or more of the following measures:

- Reorient or relocate the receiving antenna.
- Increase the separation between the equipment and the receiver.
- Connect the equipment into an outlet on a circuit different from that to which the receiver is connected.
- Consult the dealer or an experienced radio/TV technician for help.

---

Changes or modifications not expressly approved by Leica Geosystems for compliance could void the user's authority to operate the equipment.

---

## Canada

CAN ICES-003 B/NMB-003 B  
Contains IC: 216Q-PAN10

---

ICES-003 Class B Notice - Avis NMB-003 Classe B

This Class B digital device complies with Canadian ICES-003.

Cet appareil numérique classe B est conforme à la norme NMB-003 du Canada.

---

### **Canada Compliance Statement**

This device contains licence-exempt transmitter(s)/receiver(s) that comply with Innovation, Science and Economic Development Canada's licence-exempt RSS(s). Operation is subject to the following two conditions:

1. This device may not cause interference
2. This device must accept any interference, including interference that may cause undesired operation of the device

### **Canada Déclaration de Conformité**

L'émetteur/récepteur exempt de licence contenu dans le présent appareil est conforme aux CNR d'Innovation, Sciences et Développement économique Canada applicables aux appareils radio exempts de licence. L'exploitation est autorisée aux deux conditions suivantes:

1. L'appareil ne doit pas produire de brouillage
2. L'appareil doit accepter tout brouillage radioélectrique subi, même si le brouillage est susceptible d'en compromettre le fonctionnement du dispositif

---

This device and its antenna(s) must not be co-located or operating in conjunction with any other antenna or transmitter except in accordance with ISSED multi-transmitter product procedures.

This device complies with Health Canada's Safety Code. The installer of this device should ensure that RF radiation is not emitted in excess of the Health Canada's requirement.

---



Cet appareil et son (ses) antenne(s) ne doivent pas être co-localisés ou utilisés en conjonction avec une autre antenne ou un autre émetteur, sauf en conformité avec les procédures du produit multi-émetteur de la ISED. Cet appareil est conforme avec Santé Canada Code de sécurité 6. Le programme d'installation de cet appareil doit s'assurer que les rayonnements RF n'est pas émis au-delà de l'exigence de Santé Canada.

---

Responsible Party – Canada Contact Information  
Company Name: Leica Geosystems Ltd.  
CN Number: 3177B  
Street Address: 1-3761 Victoria Park Ave  
City/Province/Zip: Scarborough, Ontario M1W 3S2, Canada  
Telephone No: +1 41 6 497 2463  
Email: dwayne.louviere@leicaus.com

---

## Others

The conformity for countries with other national regulations has to be approved prior to use and operation.

---

## Appendix A

## Time Zone Offsets

Time zone offsets

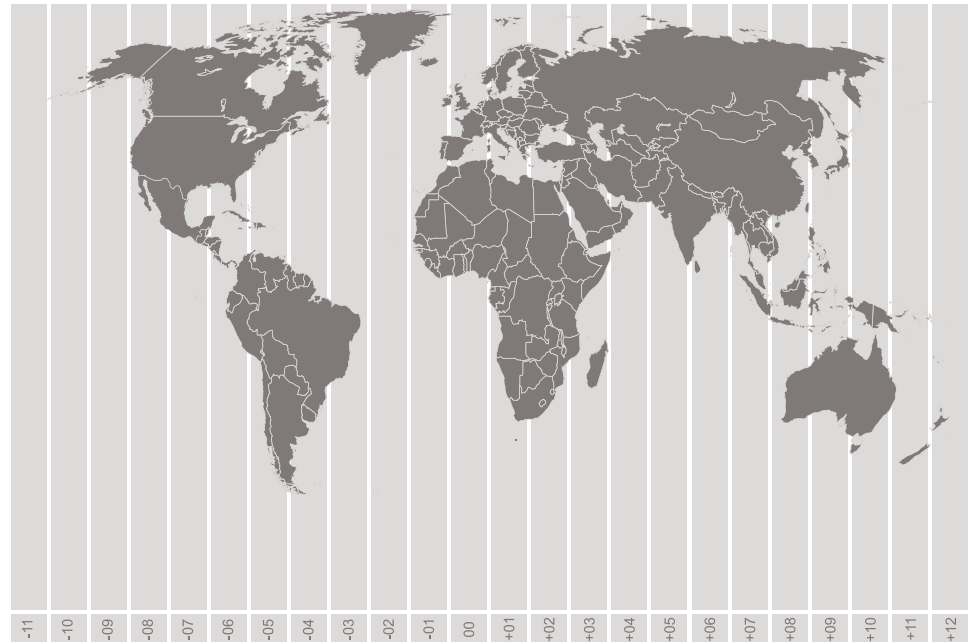





**1007895-0.9.0en**

Original text (1007895-0.9.0en)

Published in Switzerland, © 2024 Leica Geosystems AG



- when it has to be **right**



**Leica Geosystems AG**

Heinrich-Wild-Strasse  
9435 Heerbrugg  
Switzerland

[www.leica-geosystems.com](http://www.leica-geosystems.com)

