

Master Specification			
Data Collector with Bluetooth			
Model No.	OPN-4000n		
Manufacturing Specification No.	XF2OPN4000	DOC_ID	SS13055
Issue No.		Edition	1 <sup>st</sup>
Issue Date	2014-3-14		

Approved by

Optoelectronics Co., Ltd.  
 4-12-17 Tsukagoshi Warabi-shi, Saitama  
 335-0002 Japan  
 TEL +81-48-446-1183  
 FAX +81-48-446-1184

4**Revision History**

DOC\_ID :SS13055

Model No. :OPN-4000n

Edition	Date	Section	Description of Changes
1 <sup>st</sup>	2014-3-14	-	(Initial Issue)

<b>Index</b>	<b>Page</b>
1. ABSTRACT .....	1
2. OVERVIEW .....	1
3. BASIC SPECIFICATION .....	2
4. DETAILED VIEW .....	4
5. ELECTRICAL SPECIFICATIONS .....	5
5.1. USB .....	5
5.2. Charging Cradle .....	5
6. INTERFACE .....	5
6.1. USB .....	5
6.1.1. Connector .....	5
6.1.2. USB Interface Circuit .....	5
6.2. Bluetooth .....	6
7. OPTICAL SPECIFICATIONS .....	6
7.1. Basic Optical Specifications .....	6
7.2. Aiming Pattern .....	7
8. TECHNICAL SPECIFICATIONS .....	8
8.1. Bar code Test Sample .....	8
8.2. Scan Area and Depth of Field .....	9
8.3. Printed Contrast Signal (PCS) .....	9
8.4. Minimum Resolution .....	10
8.5. Wide Barcode .....	10
8.6. Petch, Skew and Tilt .....	10
8.7. Curvature .....	11
9. ENVIRONMENTAL SPECIFICATIONS .....	12
9.1. Temperature .....	12
9.2. Humidity .....	12
9.3. Ambient Light Immunity .....	12
9.4. Dust and Drip Proof .....	12
9.5. Vibration Strength(without packing) .....	12
9.6. Vibration Strength (in individual packing) .....	12
9.7. Drop Impact Strength .....	13
9.8. Drop Impact Strength (in individual packaging) .....	13
9.9. Electrical Specifications .....	13
10. REGULATORY COMPLIANCE .....	14
10.1. LED Safety .....	14
10.2. Product Safety .....	14
10.3. EMC .....	14
10.4. Other .....	15
11. ROHS .....	15
12. MTBF .....	15
13. PRECAUTIONS .....	15
13.1. Precaution against Laser Light .....	15
13.2. Handling .....	15
13.3. Radio Low .....	16

---

13.4.	Export Administration Regulations.....	16
13.5.	Bluetooth.....	16
13.6.	Frequency Band.....	16
14.	PRODUCT LABEL.....	18
15.	PACKAGING SPECIFICATIONS.....	19
15.1.	Individual Packaging Specification.....	19
15.2.	Collective Packaging Specification.....	20
16.	WARRANTY.....	21
16.1.	Warranty period.....	21
16.2.	Delivery.....	21
16.3.	Repair Timeframe.....	21
16.4.	Maintenance Period.....	21
16.5.	Other.....	21
17.	PHYSICAL FEATURES.....	21
17.1.	Dimensions.....	21
17.2.	Weight.....	21
17.3.	Mechanical Drawing.....	22
18.	SUPPORTED SYMBOLOGIES.....	23
18.1.	Menu Barcode for Default Setting.....	23
18.2.	Supported Symbologies.....	23
18.2.1.	1D symbologies.....	23
18.2.2.	GS1 Databar, Composite Code.....	24

---

## 1. Abstract

This manual provides specifications for the OPN-4000n 1D Imager Barcode Scanner.

## 2. Overview

The OPN-4000n scanner enables data transmission of barcode using Bluetooth wireless technology.

- The OPN-4000n is handy and simple data collector.  
Data transmission is performed via a USB or Bluetooth.
- The OPN-4000n has SPP and HID profiles.
- Power supply is 3.7V, 600mAh(typ.) and Lithium-ion polymer battery is used.
- The power supply charging is done via a USB interface or charging cradle.

## 3. Basic Specification

Item		Specification		Note	
Control Section	CPU	32bit CISC/96MHz			
	FROM	512Kbyte + 32KByte			
	SRAM	96Kbyte			
	FROM(strage)	1Mbyte		For user data	
Input Section	Key type	2 keys: Trigger, Function			
Display section	LED	bi-colors(red and green) 2pcs, a blue LED			
	Beeper	Tone:variable frequency, Volume:3-level variable			
RTC	Contents	year, month, day, hour, minute and second			
	Error	$\leq \pm 90$ seconds per a month			
I/F	Bluetooth	Frequency	2402MHz - 2480MHz		
		Specification	Bluetooth Ver2.1		
		Communication distance	10m		It may shorter depending on usage environments
		Output level	Class 2		2dBm max.
	Profile	SPP/HID			
USB	<ul style="list-style-type: none"> <li>•Full-Speed 12Mbps ( HID/COM )</li> <li>•Hi-Power Bus-powered</li> </ul>				
Optical Section	Scanning method		CCDLinear image sens6,7		
	Scanning light source		1 red LED		
	Effective pixels		1500		
	View angle		Horizontal: Approx. 50°		
Supported 1D Symbologies	Symbologies		JAN,EAN,UPC-A,UPC-E,NW-7 (Codabar), Industrial 2 of 5,Interleaved 2 of 5, Code 11, Code 39, Code 93, Code 128 and others		
	Minimum resolution		Code 39 : 0.1mm		PCS 0.9
	Curvature		Radius $\geq 15$ mm ( EAN8 ) Radius $\geq 20$ mm ( EAN13 )		PCS 0.9
	Wide Bar Code		Possible to read: Code 39 with 110 mm width and resolution 0.2mm		
	Scan Angle		Pitch: $\alpha \leq \pm 50^\circ$		PCS 0.9
			Skew: $\beta \leq \pm 65^\circ$ (Excluding dead zone)		
			Tilt: $\gamma \leq \pm 25^\circ$		
	Depth of field (mm)	Code 39	Resolution ( 0.127 )		75 - 120
Resolution ( 0.15 )			65 - 130		
Resolution ( 0.25 )			55 - 220		
Resolution ( 0.5 )			55 - 240		
Resolution ( 1.0 )			70 - 520		

Item		Specification		Note
	Minimum PCS		0.3 or more	MRD: 32% or more
Power	Main Battery		Lithium-ion polymer battery 600mAh(typ.)	
	Up-time		25hours or more	When a barcode is scanned twice in 10 sec. at 25 deg. C
	Range of Operation(Charging) Voltage		4.5 - 5.5 V	
	Current consumption	Charging	<500mA	
Environmental Specification	Temperature	Operating	0 - 50 °C	
		Storage	-20 - 60 °C	
	Humidity	Operating	20%RH - 85%RH	No frost, no condensation.
		Storage	20%RH - 85%RH	No frost, no condensation.
	Ambient Light Immunity	Fluorescent	10,000 lx or less	
		Sunlight:	100,000 lx or less	
	Vibration		Increase the frequency of vibration from 10 Hz to 100 Hz at an accelerated velocity of 19.6 m/s <sup>2</sup> (2G) for 6 minutes each in X, Y and Z-direction. Repeated this test for 10 times.	
	Drop		Drop 3 times, at each 6 faces (right, left, front, back and top), from a height of 120 cm onto a concrete surface.	
Dust and drip proof		IP42		
Regulatory	LED safety		IEC 62471:2006 Exempt Risk Group	Peak Wavelength : 624 nm
	Safety standards		EN60950-1:2005 IEC60950-1:2006	
	EMC		EN 55022:2010 EN 301 489-1 V1.9.2 EN 301 489-17 V2.1.1 EN 300 328 V1.7.1 FCC Part 15 Subpart C , Subpart B ClassB VCCI ClassB	For residential, commercial and light-industrial environments
	Product safety		CE Marking	
	Other		Bluetooth logo certification	
Immunity test	ESD immunity	No destruction	15kV (Air)	Condition: IEC61000-4-2 compliant
		No malfunction	8kV (Air)	
Physical Features	Dimensions		83.0(D) × 36.0(W) × 21.5(H) (mm)	
	Weight		Approx. 52g	Excluding the accessories

4. Detailed View

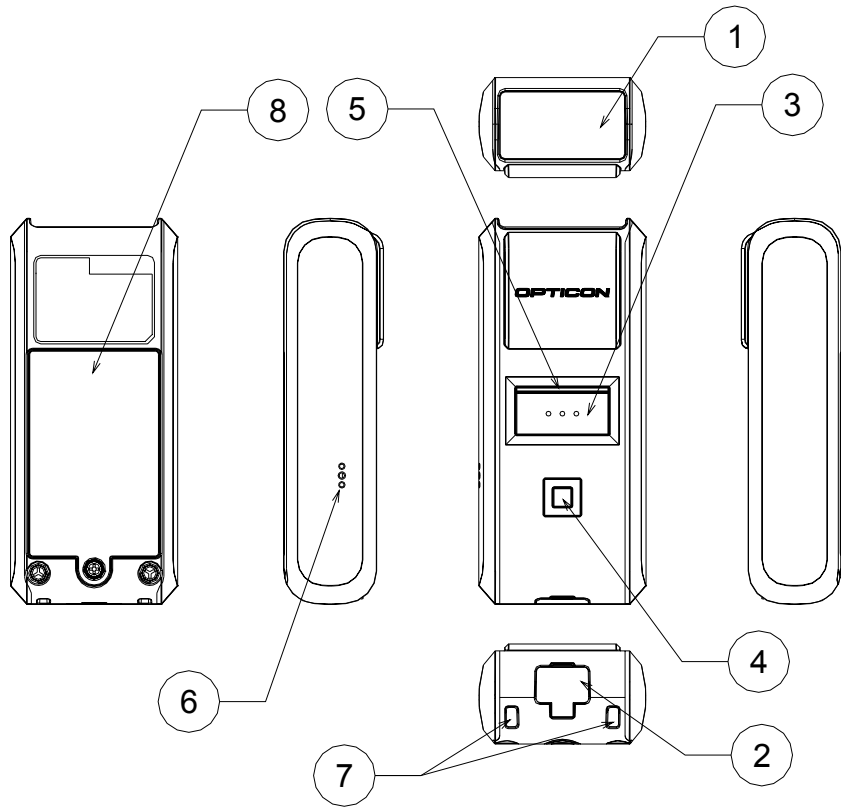

Figure 1: Detailed View

No.	Name	Description
1	Scanning Window	Laser light is emitted through this window to read bar codes.
2	Scanning Window	The laser light is emitted through this window.
3	Trigger Key	A trigger key used to read bar codes
4	Function Key	A function key that can be configured with application
5	LED	Indicator of operating status, such as bar code reading and warnings
6	Buzzer Hole	Sound from a built-in buzzer comes out through these holes.
7	Strap Hole	A hole to attach a hand strap
8	Battery Box Cover	A cover is opened to remove battery.



## 5. Electrical Specifications

### 5.1. USB

- Voltage : 4.5-5.5V
- Bus-Power Class : Hi-Power ( 500mA max )
- Current consumption : <500mA

### 5.2. Charging Cradle

- Voltage : 4.5-5.5V

## 6. Interface

The OPN-4000n supports USB, Bluetooth and serial interfaces.

### 6.1. USB

This interface supported FULL Speed USB.

#### 6.1.1. Connector

Signal	Pin No.
VCC	1
Data(-)	2
Data(+)	3
( NC )	4
GND	5

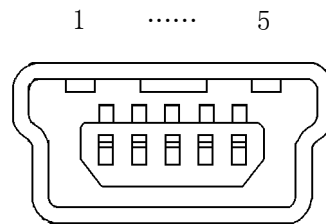

Figure 2 : MINI USB B コネクタ

#### 6.1.2. USB Interface Circuit

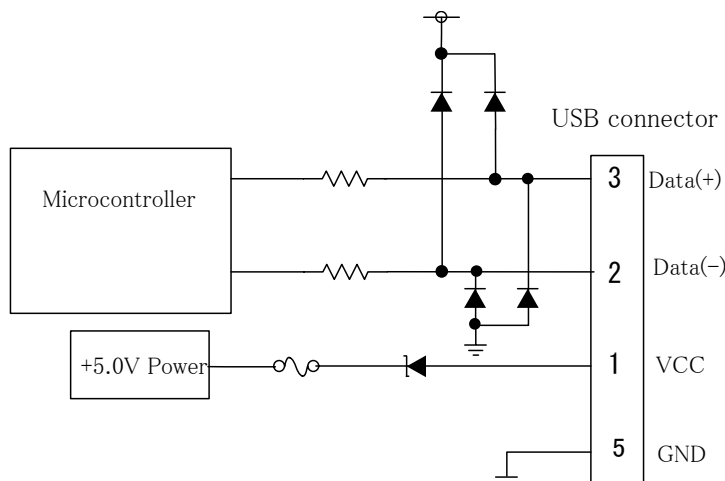

Figure 3:USBInterface Circuit

## 6.2. Bluetooth

The OPN-4000n supported Bluetooth.

Frequency	: 2402MHz - 2480MHz
Specification	: Bluetooth Ver2.1
Communication distance	: 10m
Output level	: Class 2 (2dBm Max.)
Supported profiles	: SPP/HID
Topology of connection	: Point-to-point
Operating mode	: Master or Slave mode
Security mode	: Enabled
Encryption	: Enabled

## 7. Optical Specifications

### 7.1. Basic Optical Specifications

Item		Characteristics
Scan method	CCD linear image sensor	—
Number of effective pixel	Horizontal	1500dot
Image capture speed (*1 )	Frame rate (*1)	300scan/s
Focal distance	Distance from the front edge of scanner	105 mm
View angle	Horizontal	Approx. 50°
Aiming light source	Red LED	—
	Peak wavelength	624 nm
	Maximum radiation output (*2 )	12lm

\*1 The fastest speed of image capture.

\*2 Reference value extracted from the datasheet. (25 °C、I<sub>F</sub> = 140 mA)

## 7.2. Aiming Pattern

The aiming is used for the following purpose:

1. Fill light when scanning is used.
2. Fill light to recognize the appropriate reading range.

The aiming specifications are as follows:

- An optical axis of imaging field of view and the center of horizontal aiming width coincide at a distance of  $L=83\pm 10$  mm from the front edge of the scanner.
- The horizontal aiming width to the horizontal width of imaging filed of view at a distance of  $L=83$  is  $100\%\pm 10\%$ .

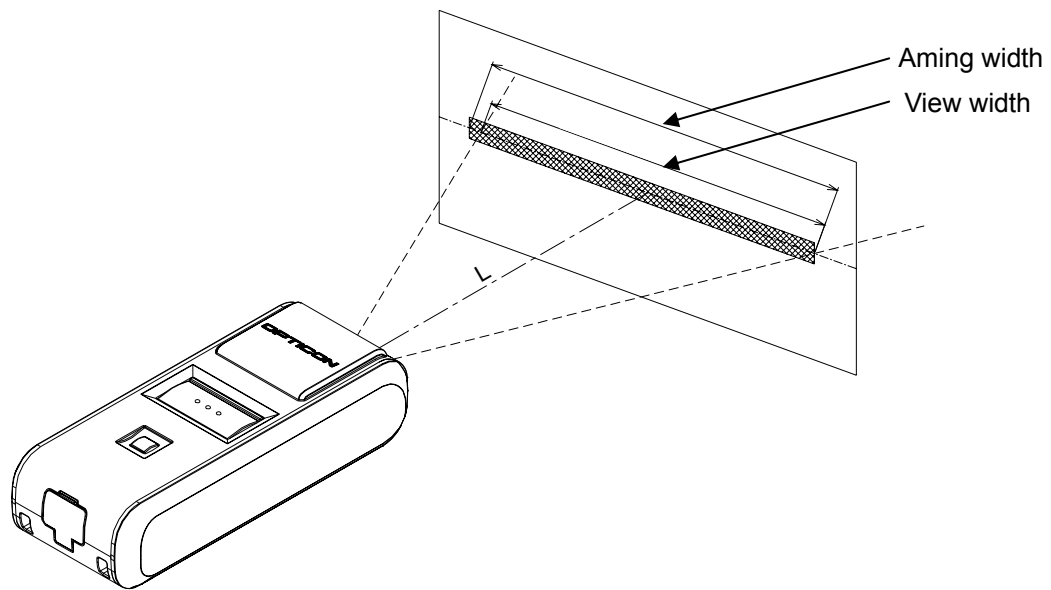

Figure 4 : Aiming Pattern and Imaging Range

## 8. Technical Specifications

The conditions for technical specifications are as follows, unless otherwise specified in each section.

### <Conditions>

Ambient Temperature and Humidity	: Room temperature, room humidity
Ambient Light	: 200-300 lx
Pitch	: $\alpha = 0^\circ$
Skew	: $\beta = 15^\circ$
Tilt	: $\gamma = 0^\circ$
Curvature	: $R = \infty$
Power supply voltage	: 3.7 V
Scanning Tests	: Performance is approved when scanning is successful in all 10 tests. Scanning is deemed successful when completed in 0.5 second or less.
Barcode Test Sample	: Specified below.

### < Test chart >

For 1D codes, OPTOELECTRONICS test samples

### 8.1. Bar code Test Sample

#### < Code 39 >

Resolution	Symbology	PCS	Margin	No. of Digits
1.0mm	Code 39	0.9	25mm	1
0.5mm			18mm	3
0.25mm			10mm	8
0.2			10mm	34
0.15mm			7mm	10
0.127mm			5mm	4
0.1mm			5mm	4

#### < JAN >

Resolution	Symbology	PCS	Margin	No. of Digits
0.26 mm	JAN	0.9	10 mm	13
0.26 mm			10 mm	8
0.33mm			10mm	13

### 8.2. Scan Area and Depth of Field

Distance in this drawing is measured from the front edge of the scanner.

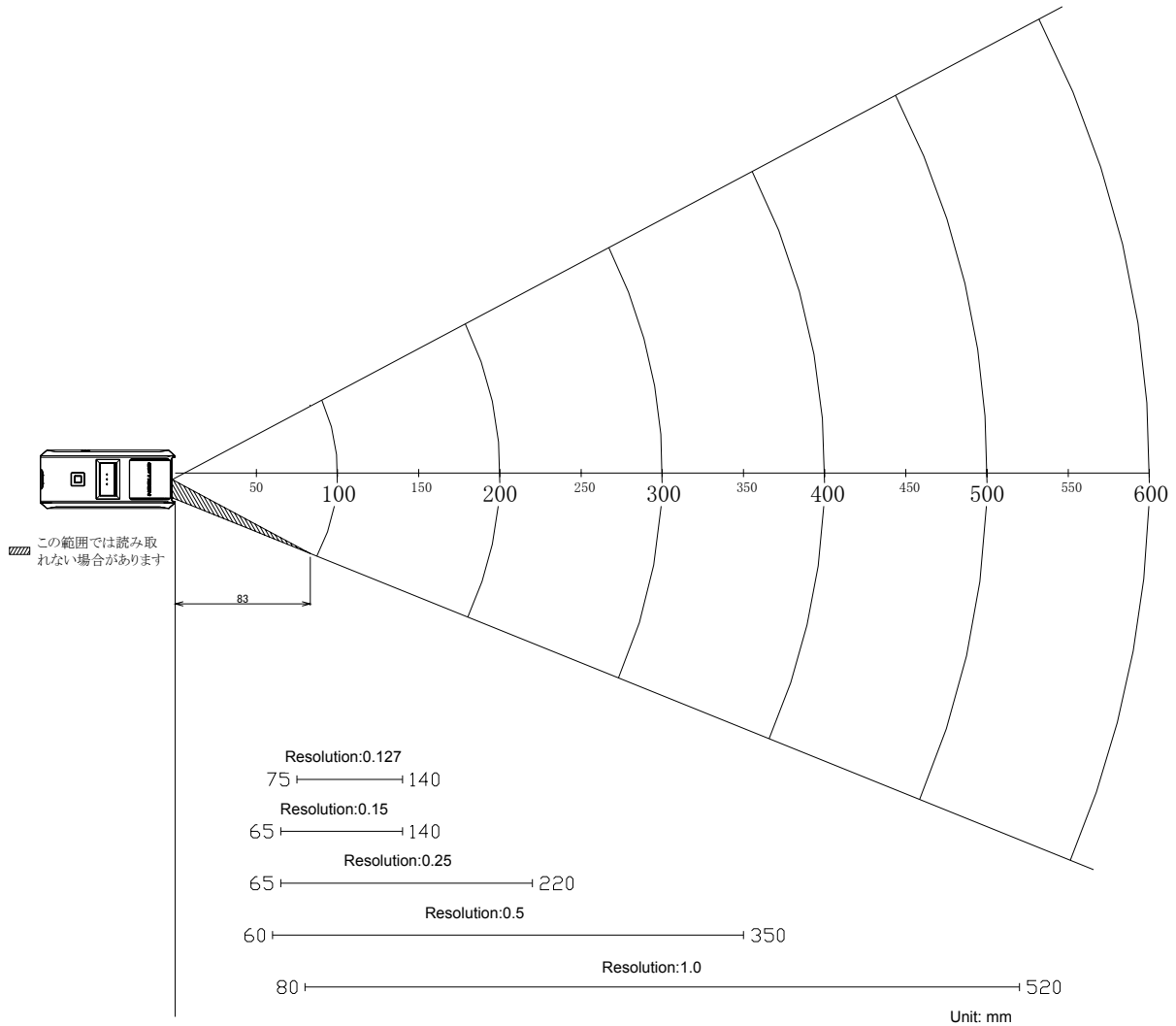

Figure 5: Depth of Field

### 8.3. Printed Contrast Signal (PCS)

0.3 or higher

<Conditions>

- MRD : 32% and higher  
(70% or higher reflectivity of space and quiet zone)
  - Distance : 105mm from the front edge of the scanner
  - Bar Code Sample : UPC specified in Chapter 8. (Resolution: 0.33 mm, PCS: 0.3)
- MRD = Minimum reflectance of white bar - Maximum reflectance of black bar

$$PCS = \frac{\text{Reflectance of white bar} - \text{Reflectance of black bar}}{\text{Reflectance of white bar}}$$

#### 8.4. Minimum Resolution

0.1mm or higher

<Conditions>

Bar Code Sample : The above codes specified in Chapter 8.1  
 Distance : 95 mm from the front edge of the scanner  
 Angle :  $\alpha = 0^\circ$ ,  $\beta = +15^\circ$ ,  $\gamma = 0^\circ$   
 Curvature :  $R = \infty$

#### 8.5. Wide Barcode

Code 39 with width of 110 mm and resolution of 0.2 mm can be read

<Conditions>

Bar Code Sample : 0.20 mm Code 39 / PCS 0.9 specified in Chapter 8.1  
 Distance : 150 mm from the front edge of the scanner  
 Angle :  $\alpha = 0^\circ$ ,  $\beta = +15^\circ$ ,  $\gamma = 0^\circ$   
 Curvature :  $R = \infty$

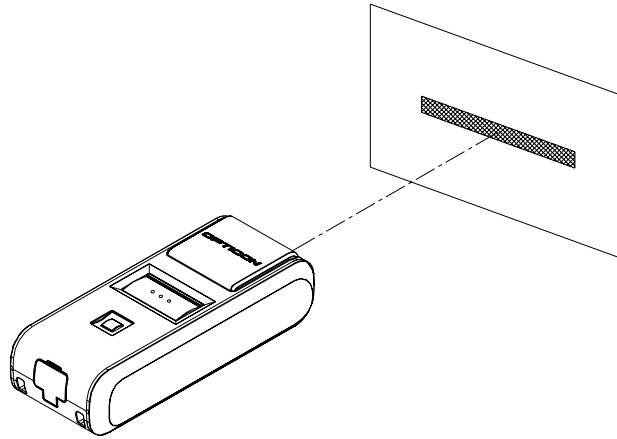

Figure 6 : Wide Barcode

#### 8.6. Petch, Skew and Tilt

Pitch :  $\alpha \leq \pm 50^\circ$  (※1)  
 Skew :  $\beta \leq \pm 65^\circ$  (※2)  
 Dead Zone :  $\beta \leq \pm 8^\circ$  (※2)  
 Tilt :  $\gamma \leq \pm 25^\circ$  (※3)

<Conditions>

Bar Code Sample : 0.26 mm JAN specified in Chapter 8.1  
 Distance : 95 mm from the edge of the scan engine  
 Curvature :  $R = \infty$

※1 ピッチ角度の条件は、 $\beta = +15^\circ$ 、 $\gamma = 0^\circ$ 、

※2 スキュー角度の条件は、 $\alpha = 0^\circ$ 、 $\gamma = 0^\circ$ 、

※3 チルト角度の条件は、 $\alpha = 0^\circ$ 、 $\beta = +15^\circ$  とします。

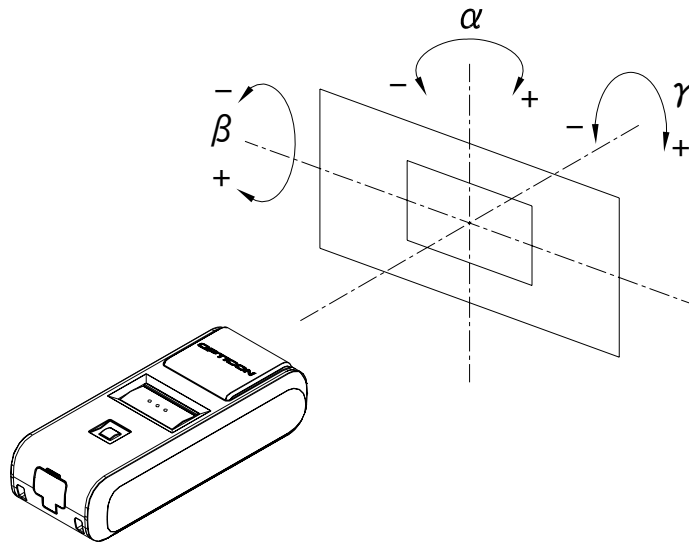

Figure 7 : Pitch, Skew and Tilt

8.7. Curvature

0.26 mm JAN 8-digit :R ≥ 15 mm

0.26 mm JAN 13-digit :R ≥ 20 mm

<Conditions>

Bar Code Sample : 0.26 mm JAN specified in Chapter 8.1

Distance : 150 mm from the edge of the scan engine

Angle : α = 0°, β = +15°, γ = 0°

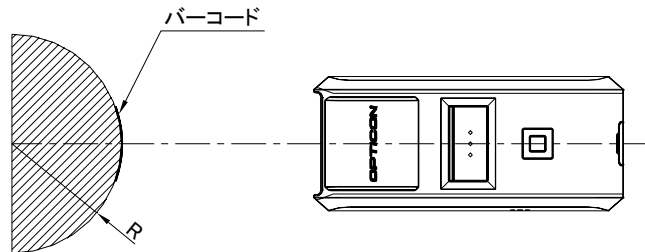

Figure 8: Curvature

Note: Scanning may fail due to the specular reflection of LED illumination when the reflectivity is high.

## 9. Environmental Specifications

### 9.1. Temperature

Operating : 0 - 50 °C  
 Storage : -20 - 60 °C

### 9.2. Humidity

Operating : 20 - 85%RH (no condensation, no frost)  
 Storage : 20 - 85%RH (no condensation, no frost)

### 9.3. Ambient Light Immunity

Scanning performance is guaranteed when the range of illumination on a barcode surface is the following values.

Incandescent light : 0 - 10,000 lx  
 Fluorescent light : 0 - 10,000 lx  
 Sunlight : 0 - 100,000 lx

#### <Conditions>

Bar Code Sample : 0.26mm JAN specified in Chapter 8.1  
 Distance : 95mm from the front edge of the camera module  
 Angle :  $\alpha = 0^\circ$ ,  $\beta = +15^\circ$ ,  $\gamma = 0^\circ$   
 Curvature :  $R = \infty$   
 Power Supply Voltage : 3.7 V

\* Be sure that the direct light or specular reflection from the light source does not enter the light receiving section of the OPN-4000n

### 9.4. Dust and Drip Proof

IEC IP42 equivalent

#### Protection against solid objects: Level 4

Protected against solid objects greater than 1.0 mm

#### Protection against liquids: Level 2 (JIS IPX2)

Protected against dripping water from the vertical when tilted up to 15°

### 9.5. Vibration Strength(without packing)

There shall be no sign of malfunction after the following vibration test.

**Vibration test:** Increase the frequency of the vibration from 10Hz to 100Hz at an accelerated velocity of 19.6m/s<sup>2</sup> (2.0 G) for 30 minutes (60 minutes for a cycle) in the non-operating state. Repeat this in each X, Y and Z direction.

### 9.6. Vibration Strength (in individual packing)

There shall be no sign of malfunction after the following vibration test.

**Vibration test:** Increase the frequency of the vibration from 10Hz to 100Hz at an accelerated velocity of 19.6 m/s<sup>2</sup> (2.0 G) for 30 minutes (60 minutes for a cycle) in individually packaged state. Repeat this in each X, Y and Z direction.



9.7. Drop Impact Strength

There shall be no sign of malfunction after the following drop test.

**Drop test:** Drop the scanner three times (18 times in total), at each 6 face, from a height of 150cm onto a concrete floor as shown below.

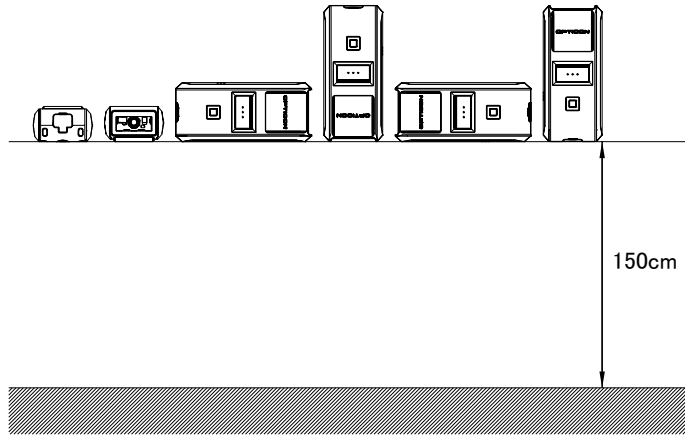

Figure 10: Drop test

9.8. Drop Impact Strength (in individual packaging)

There shall be no sign of malfunction after the following drop test.

**Drop test:** Drop an individually packaged scanner 10 times in total, at any of 1 corner, 3 edges, and 6 faces, from a height of 150 cm onto a concrete floor.

9.9. Electrical Specifications

Air discharge	±8 kV max. (No malfunction) ±15 kV max. (No destruction)
Measurement environment	An electrostatic testing device compliant with IEC 61000-4-2 is used.
Discharge resistance	330 Ω
Charging capacitor	150 pF

## 10. Regulatory Compliance

### 10.1. LED Safety

IEC 62471:2006 Exempt Risk Group

### 10.2. Product Safety

EN60950-1:2005

IEC60950-1:2006

### 10.3. EMC

R & TTE directive

• EN 55022:2010

• EN 301 489-1 V1.9.2

• EN 301 489-17 V2.1.1

• EN 300 328 V1.7.1

FCC Part 15 Subpart C , Subpart B ClassB

#### Federal Communications Commission Notices

This product complies with Part 15 of the FCC Rules. Operation is subject to the following two conditions:

- (1) this device may not cause harmful interference, and
- (2) this device must accept any interference received, including interference that may cause undesired operation.

#### Harmful Interference Notice

This product has been tested and complies with the specifications for a Class B digital device, pursuant to Part 15 of the FCC Rules. These limits are designed to provide reasonable protection against harmful interference in a residential installation. This equipment generates, uses, and can radiate radio frequency energy and, if not installed and used according to the instructions, may cause harmful interference to radio communications. However, there is no guarantee that interference will not occur in a particular installation. If this equipment does cause harmful interference to radio or television reception, which is found by turning the equipment off and on, the user is encouraged to try to correct the interference by one or more of the following measures:

- Reorient or relocate the receiving antenna
- Increase the separation between the equipment or devices
- Connect the equipment to an outlet other than the receiver's
- Consult a dealer or an experienced radio/TV technician for assistance

Changes or modifications to this equipment that have not been approved by Ruckus Wireless may void the user's authority to operate this equipment.

#### VCCI Class B

This is a Class B product, to be used in a domestic environment, based on the Technical Requirement of the Voluntary Control Council for Interference from Information Technology Equipment (VCCI). If this is used near a radio or television receiver in a domestic environment, it may cause radio interference.

## 10.4. Other

### Bluetooth logo certification

The OPN-4000n uses Bluetooth module which qualifies as radio equipment for low-power radio stations as specified in the Radio Law 38-24-1.

Specified Radio Equipment :

Low power data communications system in the 2.4GHz band in Article 2 paragraph 1 item (19), Ordinance of MPT.

Model type of Bluetooth module: OPA-26X1

Number of certification: 201-125603

## 11. RoHS

The OPN-4000n is compliant with RoHS.

RoHS: The restriction of use of certain hazardous substance in electrical and electronic equipment, 2011/65/EU.

## 12. MTBF

MTBF (Mean Time Between Failures) 10,000 hours

## 13. Precautions

### 13.1. Precaution against Laser Light

\*Use of controls or adjustments or performance of procedures other than those specified herein may result in hazardous radiation exposure.

Caution - Do not stare into the laser light from a scanning window. It may harm your eyes.

Do not point the laser directly at others' eyes. It may harm your eyes.

Do not stare into the beam with optical instruments. It may harm your eyes.

### 13.2. Handling

Handle this product carefully. Do not deliberately subject it to any of the following:

#### (1) Shock:

- Do not drop this product from a height greater than specified in this manual.
- Do not place this product under or between any heavy items.
- Do not swing this product around holding the hand strap.

#### (2) Temperature Conditions:

- Do not use this product at temperatures outside the specified range.
- Do not pour boiling water on this product.
- Do not throw this product into a fire.

#### (3) Foreign Materials:

- Do not immerse this product in water or other liquid.
- Do not expose this product to chemicals.

#### (4) Others

- Do not disassemble this product.
- Do not use this product near a radio or a TV. It may cause reception problems.
- This product may be affected by a momentary voltage drop caused by lightning.
- This product may not perform properly in a place where it will be subjected to a flickering light, such as a CRT (computer monitor, television, etc.).

### 13.3. Radio Low

The OPN-4000n uses Bluetooth module which qualifies as radio equipment for low-power radio stations (2.4 GHz band advanced data communication systems) as specified in the Radio Law 38-24-1.

Therefore it does not need to have a radio station license in Japan.

The following activities are prohibited under the Radio Law:

- Remodeling and disassembly
- Peeling off the certificate label

Do NOT use the scanner under the following environment, as radio interference may affect other device and end up with causing physical or material damage.

- Safety apparatus and medical device for human body protection
- Environment where is concerned to cause serious damage

### 13.4. Export Administration Regulations

This product is subject to the strategically controlled exports regulated under "Foreign Exchange and Foreign Trade Laws". Therefore, export of this product may require an export permission of Japanese government.

### 13.5. Bluetooth

To communicate via Bluetooth, the device which OPN-4000n is connected to must support the same Bluetooth version and profile as OPN-4000n's.

- OPN-4000n is compliant to Bluetooth standards. However, we cannot assure the connection between OPN-4000n and other Bluetooth devices which have not been tested.
- Bluetooth supporting devices use 2.4 GHz frequency band. However, many other sorts of devices also utilize this frequency band. It may have an effect on the communication speed or communication range of this data collector.
- The use of OPN-4000n outside of the European Union, the United States and Canada is punishable under the law.
- Communication speed and communication range of OPN-4000n may differ due to the obstacles and radio wave conditions between OPN-4000n and the device, which OPN-4000n is connected to.
- Conditions of the device, which OPN-4000n is connected to, may also affect the communication speed and communication range of OPN-4000n.

### 13.6. Frequency Band

The frequency band 2.4 GHz is utilized by this product. Read carefully the followings before using this product.

In the frequency band of this product, scientific, medical and industrial devices including microwaves are used. Also other radio stations including local private radio station for mobile object identification requiring license for such as manufacturing lines at factories, specific power-saving radio station requiring no license and amateur radio station are managed.

1. Please make sure that "other radio stations" are not managed in the frequency band 2.4 GHz before

using this product.

2. In case that radio interference occurs between this product and "other radio stations," change the service space immediately, or stop transmitting radio wave to avoid the interference.
3. If you have any questions or troubles, please contact our sales office.

\* This specification manual is subject to change without prior notice.

### 14. Product Label

The labels shown below are attached to the back side of the data collector.

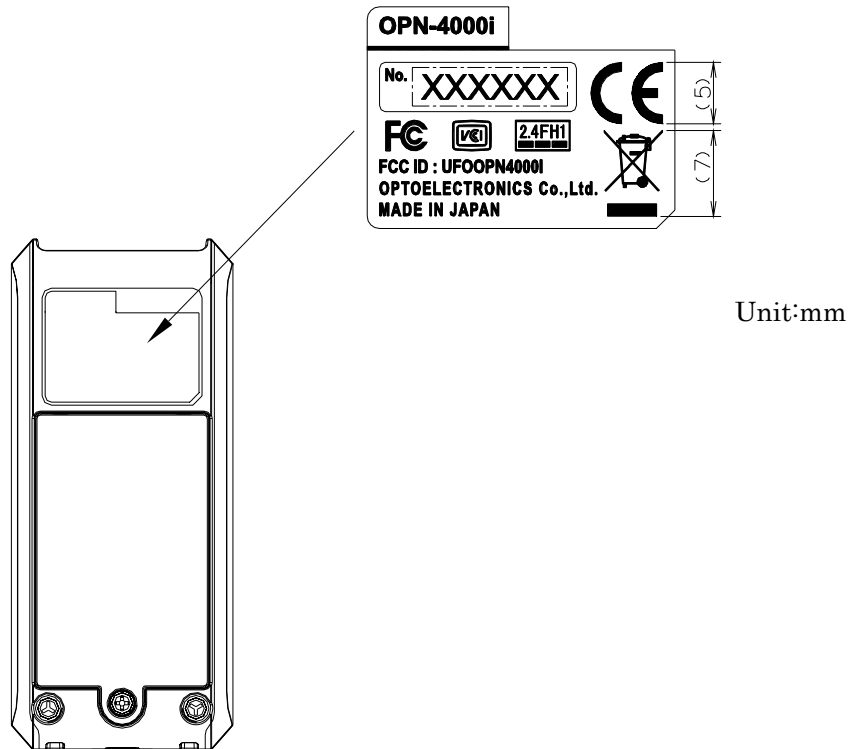

Figure 11: Product & Laser Caution Label

### 15. Packaging Specifications

#### 15.1. Individual Packaging Specification

Assembled package size: 125 x 112 x 40 (WDH mm)

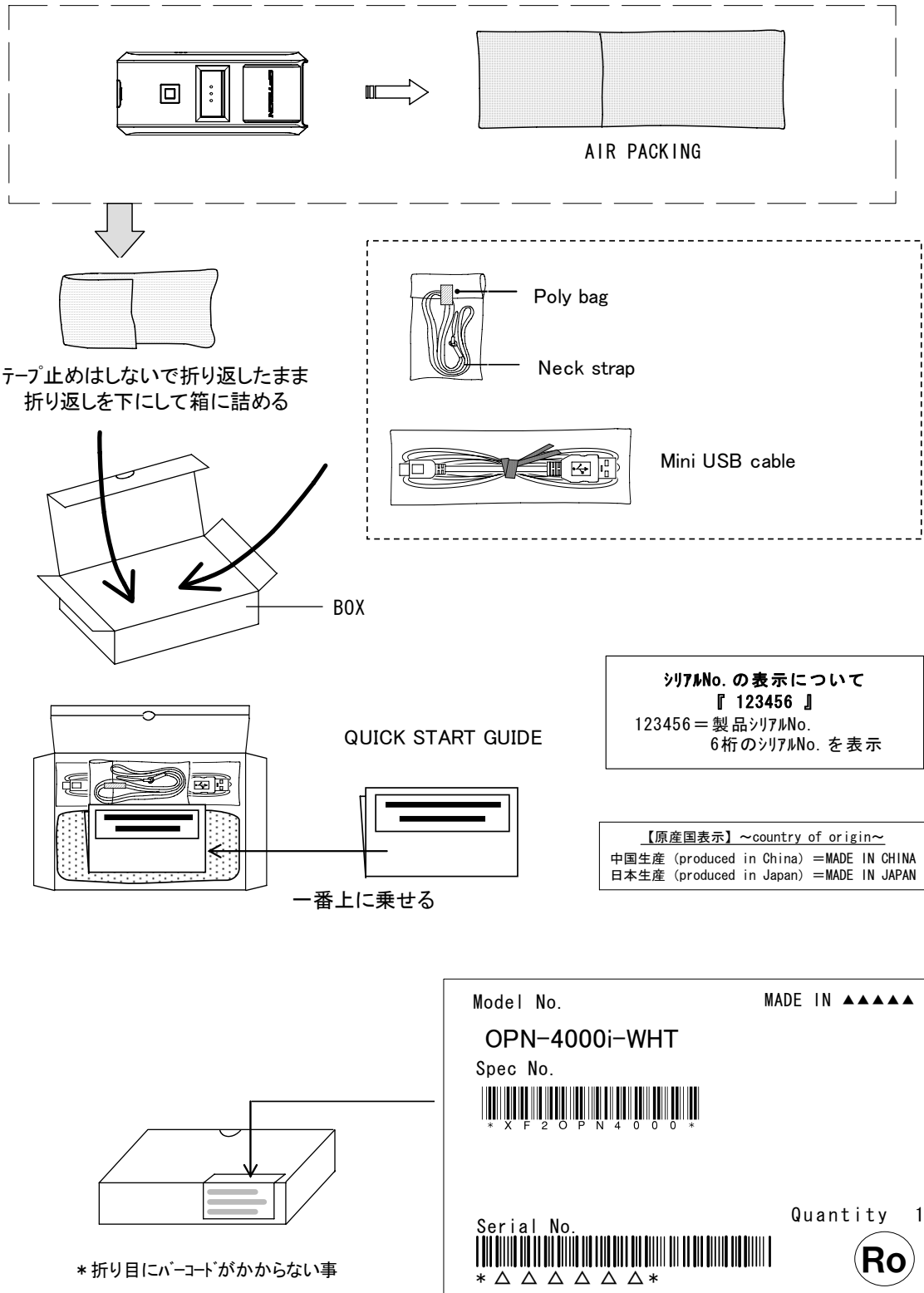
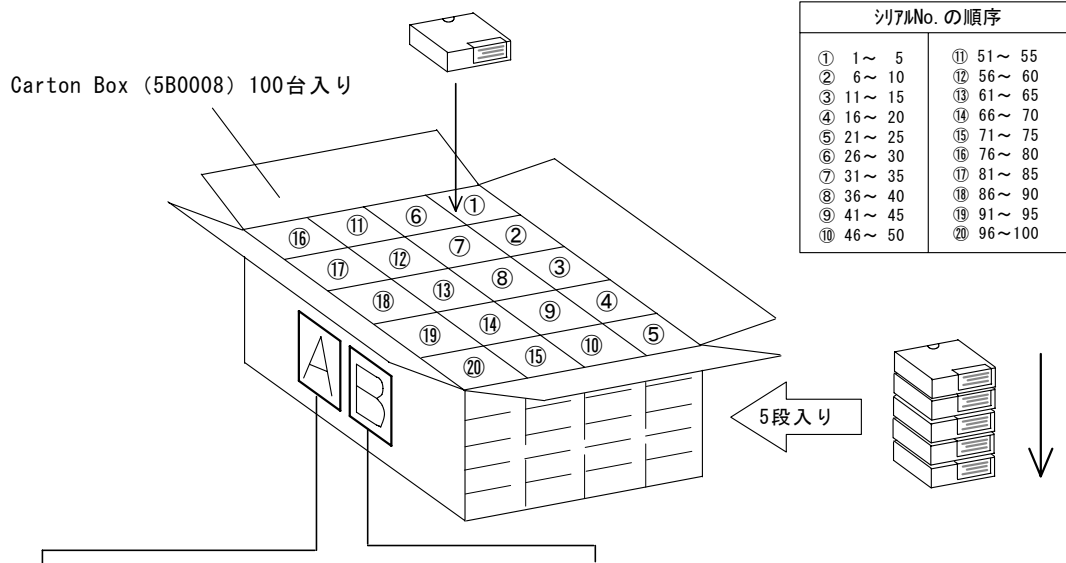

Figure 12: 個装梱包図

15.2. Collective Packaging Specification

Assembled package size: 595 x 520 x 245 (WDH mm), 100 pieces/box



**A : 【国内向】 外装箱バーコードラベル**  
正面と背面の2ヶ所に貼付(面の中央付近)

**B : 【国内向】 Missing Serial Numberラベル**  
欠品が3つ以上の場合にのみ貼付する  
Aラベルと並べ 正面と背面の2ヶ所に貼付(面の中央付近)

(3C0006)

C/No.  $\triangle \triangle$   
MADE IN  $\blacktriangle \blacktriangle \blacktriangle \blacktriangle \blacktriangle \blacktriangle$



Product **OPN-4000i-WHT**

Spec#   
\* X F 2 0 P N 4 0 0 0 \*

Q'ty   $\triangle \triangle / \triangle \triangle$   
\*  $\triangle \triangle$  \*

S/N (from)   
\*000001\*

S/N (to)   
\*000 $\blacktriangle \blacktriangle \blacktriangle$ \*

Missing Serial Number	Missing Q'ty $\triangle$
1	 * $\triangle \triangle \triangle \triangle \triangle \triangle$ *
2	 * $\triangle \triangle \triangle \triangle \triangle \triangle$ *









ROM-Ver. (MAIN) TC08J\*\*  
ROM-Ver. (Bluetooth) TD01J\*\*  
Shipping Date 20 $\triangle \triangle / \triangle \triangle / \triangle \triangle$



OPTOELECTRONICS CO., LTD.

(3C0007)

C/No.  $\triangle \triangle$   
MADE IN  $\blacktriangle \blacktriangle \blacktriangle \blacktriangle \blacktriangle \blacktriangle$

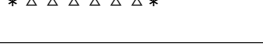
Missing Serial Number	Missing Q'ty $\triangle \triangle$
3	 * $\triangle \triangle \triangle \triangle \triangle \triangle$ *
4	 * $\triangle \triangle \triangle \triangle \triangle \triangle$ *
5	 * $\triangle \triangle \triangle \triangle \triangle \triangle$ *
6	 * $\triangle \triangle \triangle \triangle \triangle \triangle$ *
7	 * $\triangle \triangle \triangle \triangle \triangle \triangle$ *
8	 * $\triangle \triangle \triangle \triangle \triangle \triangle$ *
9	 * $\triangle \triangle \triangle \triangle \triangle \triangle$ *
10	 * $\triangle \triangle \triangle \triangle \triangle \triangle$ *
11	 * $\triangle \triangle \triangle \triangle \triangle \triangle$ *
12	 * $\triangle \triangle \triangle \triangle \triangle \triangle$ *

OPTOELECTRONICS CO., LTD.

【原産国表示】 ~country of origin~  
中国生産 (produced in China) =MADE IN CHINA 日本生産 (produced in Japan) =MADE IN JAPAN

※弊社製品用の梱包箱に貼られております Ro のマークは、当該製品が弊社の判断により RoHS 指令 (The restriction of use of certain hazardous substance in electrical and electronic equipment, 2011/65/EU.) に適合したことを宣言するものです。

Figure 13: 集合梱包図



## 16. Warranty

### 16.1. Warranty period

OPTOELECTRONICS Co., Ltd. warrants that this product is free of defects or malfunctions for a period of twelve (12) months from its shipment. In case of having defects or malfunctions caused by normal usage in accordance with this specification during the foregoing warranty period, OPTOELECTRONICS shall repair or adjust the product free of charge.

Any repair or replacement of the product after the foregoing warranty period shall be charged at regular repair rates.

If defects or malfunctions were caused by customer mishandling, product repairs or replacement will be charged at regular repair rates, even during the foregoing warranty period.

### 16.2. Delivery

Products for maintenance or repair shall be sent back to OPTOELECTRONICS. The sender is responsible for all shipping costs.

### 16.3. Repair Timeframe

Repaired products shall be shipped back to the customer within 20 days after acceptance by OPTOELECTRONICS.

Expedited repairs may be available, subject to terms agreed to by OPTOELECTRONICS and the customer.

### 16.4. Maintenance Period

The maintenance period of this product is 5 years after its shipment.

OPTOELECTRONICS may discontinue maintenance for this product during the 5-year maintenance period if a satisfactory replacement product or maintenance solution is agreed to.

### 16.5. Other

Any additional warranty issues must be discussed with OPTOELECTRONICS on a case-by-case basis.

## 17. Physical Features

### 17.1. Dimensions

83.0(D) × 36.0(W) × 21.5(H) (mm)

### 17.2. Weight

Approx. 52g (Excluding the accessories)

17.3. Mechanical Drawing

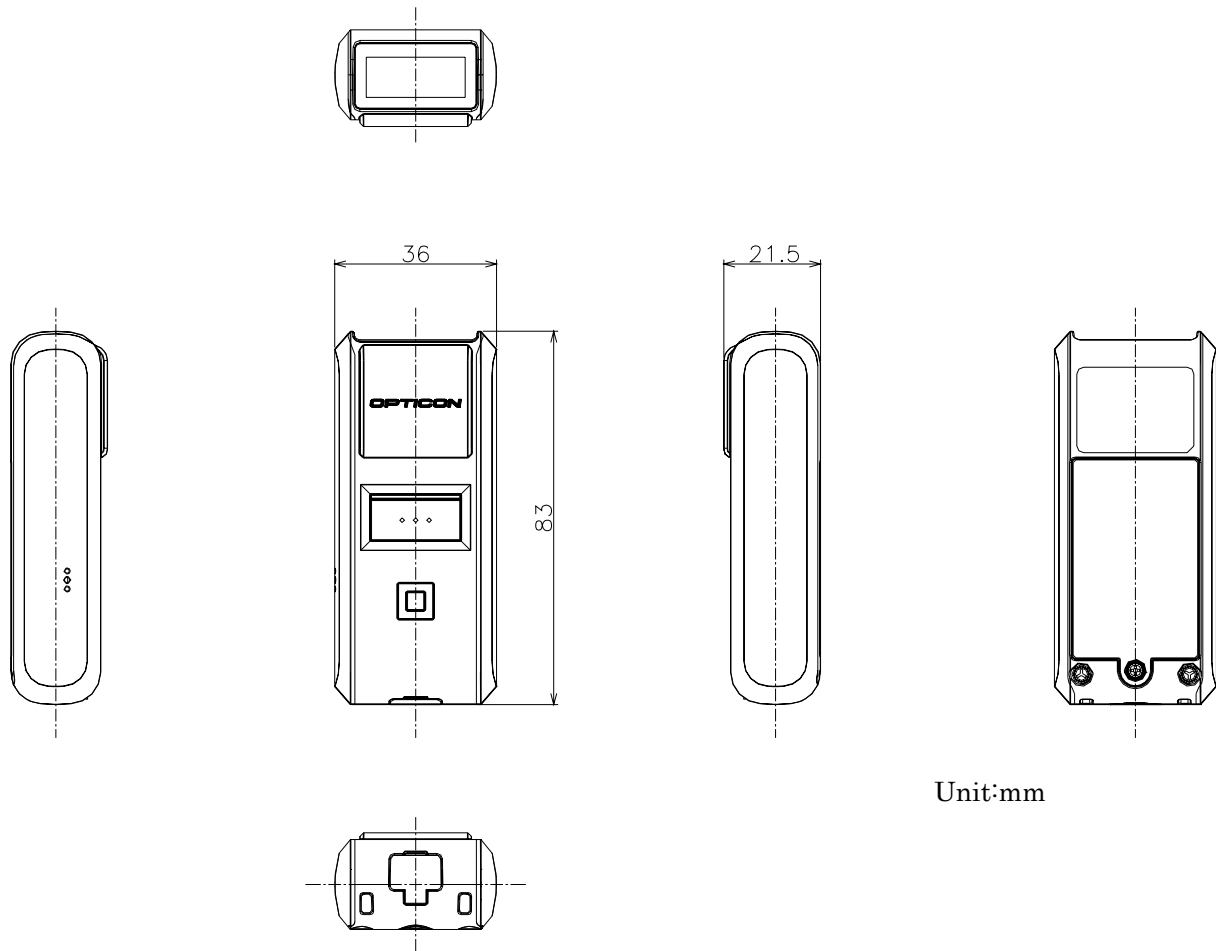





Figure 14: Outline drawing

### 18. Supported Symbologies

#### 18.1. Menu Barcode for Default Setting

Menu barcodes are prepared for the default setting to make the setting easier.

Functions	Menu labels	Menu codes
SET		ZZ
Default		SO
END		ZZ

#### 18.2. Supported Symbologies

##### 18.2.1. 1D symbologies

Code type	Default	Remarks	Code type
UPC	<input type="radio"/>	-	
UPC Add-on 2			
UPC Add-on 5			
EAN(JAN)	<input type="radio"/>	-	
EAN Add-on 2			
EAN Add-on 5			
EAN-13	<input type="radio"/>		
EAN-13 Add-on 2			
EAN-13 Add-on 5			
EAN-8	<input type="radio"/>		
EAN-8 Add-on 2			
EAN-8 Add-on 5			
Code 39	<input type="radio"/>	1	Not transmit ST/SP
Tri-Optic	<input type="radio"/>	-	Not transmit ST/SP
Codabar (NW7)	<input type="radio"/>	5	Not transmit ST/SP
Industrial 2of 5	<input type="radio"/>	5	
Interleaved 2of 5	<input type="radio"/>	6	
S-Code		5	
Code 128	<input type="radio"/>	1	GS1 conversion (setting required)
Code 93	<input type="radio"/>	1	
IATA	<input type="radio"/>	5	
MSI/Plessey	<input type="radio"/>	3	
UK/Plessey		2	
Telepen	<input type="radio"/>	1	
Code 11		1	
Matrix 2 of 5		5	
Chinese Post Matrix 2 of 5		-	
Korean Postal Authority		-	

18.2.2. GS1 Databar, Composite Code

Code type	Default	Remarks
<b>GS1 DataBar</b> •GS1 DataBar Omnidirectional •GS1 DataBar Truncated •GS1 DataBar Stacked •GS1 DataBar Stacked Omnidirectional		GS1 conversion (setting required)
<b>GS1 DataBar Limited</b>		
<b>GS1 DataBar Expanded</b> •GS1 DataBar Expanded •GS1 DataBar Expanded Stacked		