

Master Specification			
Data Collector with Bluetooth			
Model No.	OPN-3002n		
Manufacturing Specification No.	XF2OPN3002	DOC_ID	SS13022
Issue No.		Edition	1 st
Issue Date	2013- -		

Approved by

Optoelectronics Co., Ltd.
 4-12-17 Tsukagoshi Warabi-shi, Saitama
 335-0002 Japan
 TEL +81-48-446-1183
 FAX +81-48-446-1184

営業	営業管理	CS	QA/QC	照査	作成

Revision History

DOC_ID :SS13022

Model No. :OPN-3002n

Edition	Date	Section	Description of Changes
1 st	2013- -	-	(Initial Issue)

Index	page
1. ABSTRACT	1
2. OVERVIEW.....	1
3. BASIC SPECIFICATION	2
4. DETAILED VIEW.....	5
5. ELECTRICAL SPECIFICATIONS.....	6
5.1. USB.....	6
5.2. Charging Cradle.....	6
6. INTERFACE	6
6.1. USB.....	6
6.1.1. Connector.....	6
6.1.2. USB Interface Circuit.....	6
6.2. Bluetooth	7
7. OPTICAL SPECIFICATIONS	7
7.1. Basic Optical Specifications	7
7.2. Aiming Pattern.....	8
7.3. Imaging Range	8
8. TECHNICAL SPECIFICATIONS	9
8.1. Bar code Test Sample.....	9
8.2. Scan Area and Depth of Field	11
8.3. Printed Contrast Signal (PCS).....	11
8.4. Minimum Resolution	12
8.5. Wide Barcode	12
8.6. Petch, Skew and Tilt	12
8.7. Curvature	13
9. ENVIRONMENTAL SPECIFICATIONS	14
9.1. Temperature	14
9.2. Humidity.....	14
9.3. Ambient Light Immunity	14
9.4. Dust and Drip Proof.....	14
9.5. Vibration Strength(without packing)	15
9.6. Vibration Strength (in individual packing).....	15
Drop Impact Strength.....	15
9.7. Drop Impact Strength (in individual packaging)	15
9.8. Electrical Specifications	15
10. REGULATORY COMPLIANCE	16
10.1. LED Safety	16
10.2. Product Safety	16
10.3. EMC	16
10.4. Other	17
11. ROHS	17
12. MTBF	17
13. PRECAUTIONS.....	17
13.1. Precaution against Laser Light	17
13.2. Handling.....	17
13.3. Radio Low	18

13.4.	Export Administration Regulations.....	18
13.5.	Bluetooth	18
13.6.	Frequency Band	18
14.	PRODUCT LABEL	20
15.	PACKAGING SPECIFICATIONS	21
15.1.	Individual Packaging Specification	21
15.2.	Collective Packaging Specification	22
16.	WARRANTY.....	23
16.1.	Warranty period	23
16.2.	Delivery.....	23
16.3.	Repair Timeframe	23
16.4.	Maintenance Period	23
16.5.	Other	23
17.	PHYSICAL FEATURES	23
17.1.	Dimensions	23
17.2.	Weight.....	23
17.3.	Mechanical Drawing.....	24
18.	SUPPORTED SYMBOLOGIES.....	25
18.1.	1D symbologies.....	25
18.2.	GS1 Databar, Composite Code.....	26
18.3.	2D codes	26

1. Abstract

This manual provides specifications for the OPN-3002n 2D Imager Barcode Scanner.

2. Overview

The OPN-3002n scanner enables data transmission of barcode using Bluetooth wireless technology.

- The OPN-3002n is handy and simple data collector.
Data transmission is performed via a USB or Bluetooth.
- The OPN-3002n has SPP and HID profiles.
- Power supply is 3.7V, 600mAh(typ.) and Lithium-ion polymer battery is used.
- The power supply charging is done via a USB interface or charging cradle.
- MFi license agreement approved by Apple Inc.

3. Basic Specification

Item		Spedification		Note	
Control Section	CPU	32bit CISC/96MHz			
	FROM	512Kbyte + 32KByte			
	SRAM	96Kbyte			
	FROM(strage)	1Mbyte		For user data	
Input Section	Key type	2 keys: Trigger, Function			
Display section	LED	bi-colors(red and green) 2pcs, a blue LED			
	Beeper	Tone:variable frequency, Volume:3-level variable			
	Vibration motor	Amplitude:3-level variable			
RTC	Contents	year, month, day, hour, minute and second			
	Error	$\leq \pm 90$ seconds per a month			
I/F	Bluetooth	Frequency	2402MHz - 2480MHz		
		Specification	Bluetooth Ver2.1		
		Communication distance	10m		It may shorter depending on usage environments
		Output level	Class 2		4dBm max.(25°C)
		Profile	SPP/HID		
	USB	<ul style="list-style-type: none"> ·Full-Speed 12Mbps (HID/COM) ·Hi-Power Bus-powered 対応 			
Serial interface	2contacts for cradle.				
Optical Section	Scanning method	WVGA (0.36 million-pixel) CMOS area sensor		Frame rate: 60 fps	
	Scanning light source	2 red LEDs			
	Aiming light source	1 green LED			
	Effective pixels	0.36 million pixels (H: 752 x V: 480)			
	View angle	Horizontal: about 40.6° Vertical: about 26.4°			
Supported 1D Symbolgies	Symbologies	UPC-A, UPC-A Add-on, UPC-E, UPC-E Add-on, EAN-13, EAN-13 Add-on, EAN-8, EAN-8 Add-on, JAN-8, JAN-13, Code 39, Tri-Optic, Codabar (NW-7), Industrial 2 of 5, Interleaved 2 of 5, S-Code, IATA, Code 93, Code 128, MSI/Plessey, UK/Plessey, TELEPEN, Matrix 2 of 5, Chinese Post Matrix 2 of 5, Code 11, Korean Postal Authority code, Postal Code			
	Minimum resolution	Code 39 : 0.127 mm		PCS 0.9	
	Curvature	Radius \geq 16 mm (12-digit 0.15mm Codabar) Radius \geq 20 mm (13-digit UPC)		PCS 0.9	
	Wide Bar Code	Possible to read: Code 39 with 100 mm width and resolution 0.2mm (DOF: 135 mm)			

	Motion tolerance		Possible to read: UPC 100% moving at 2 m/s (DOF: 100 mm)		
	Depth of field (mm)	Code 39	Resolution (0.127)	65 - 105	
			Resolution (0.254)	45 - 185	
			Resolution (0.508)	50- 250	
		Code 128	Resolution (0.2)	65 - 150	
UPC	Resolution (0.33)	45 - 175			
GS1/Composite	Symbologies		GS1 DataBar, GS1 DataBar Limited, GS1 DataBar Expanded, Composite GS1-DataBar, Composite GS1-128, Composite EAN, Composite UPC		GS1 DataBar: formerly called "RSS"
	Minimum resolution		GS1 DataBar : 0.169 mm Composite Code: 0.169 mm		
Supported 2D Symbologies	Symbologies		PDF417, MicroPDF417, Codablock F, QR Code , Micro QR Code, DataMatrix (ECC 0 - 140 / ECC 200), MaxiCode (Modes 2 to 5), Aztec Code, Chinese Sensible Code		Disable Code 128 when Codablock F is enabled.
	Minimum resolution (mm)		PDF417 : 0.169 mm QR Code : 0.212 mm DataMatrix : 0.212 mm		PCS 0.9
	Depth of field (mm)	PDF417	Resolution (0.169)	60- 120	PCS 0.9
			Resolution (0.254)	45 - 185	
		QR Code	Resolution (0.212)	70 - 95	
Resolution (0.381)			35 - 165		
DataMatrix	Resolution (0.254)	65 - 120			
Common	Scan angle		Pitch : ±40°		
			Skew : ±50°		
			Tilt : ±180°		
	Minimum PCS		0.3 or more		MRD: 32% or more

Item		Specification	Note
Power	Main Battery	Lithium-ion polymer battery 600mAh(typ.)	
	Up-time	10hours or more	When a barcode is scanned twice in 10 sec. at 25 deg. C
	Range of Operation(Charging) Voltage	4.5 - 5.5 V	
	Current consumption	Charging <500mA	
Environmental Specification	Temperature	Operating 0 - 50 °C	
		Storage -20 - 60 °C	
	Humidity	Operating 20%RH - 85%RH	No frost, no condensation.
		Storage 20%RH - 85%RH	No frost, no condensation.
	Ambient Light Immunity	Fluorenscent 10,000 lx or less	
		Sunlight: 100,000 lx or less	
	Vibration	Increase the frequency of vibration from 10 Hz to 100 Hz at an accelerated velocity of 19.6 m/s ² (2G) for 6 minutes each in X, Y and Z-direction. Repeated this test for 10 times.	
	Drop	Drop 3 times, at each 6 faces (right, left, front, back and top), from a height of 120 cm onto a concrete surface.	
Dust and drip proof	IP42		

Item		Specification	Note
Regulatory	LED safety	IEC 62471-1:2006 Exempt Risk Group	
	Safety standards	EN60950-1:2005 IEC60950-1:2006	
	EMC	EN55022 EN55024 FCC Part 15 Subpart C , Subpart B ClassB VCCI ClassB	For residential, commercial and light-industrial environments
	Product safety	CE Marking	
	Other	Bluetooth logo certification MFi License program	
Immunity test	ESD immunity	No destruction 15kV (Air)	Condition: IEC61000-4-2 compliant
		No malfunction 8kV (Air)	
Physical Features	Dimensions	83.0(D) × 36.0(W) × 21.5(H) (mm)	
	Weight	Approx. 57g	Excluding the accessories

4. Detailed View

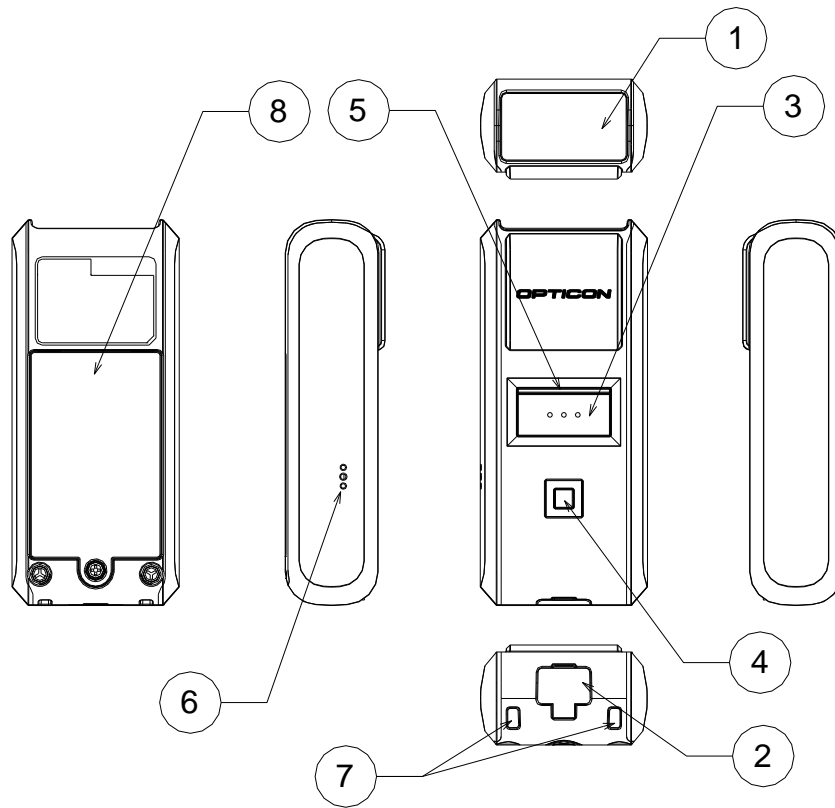

Figure 1:Detailed View

No.	Name	Description
1	Scanning Window	Laser light is emitted through this window to read bar codes.
2	Scanning Window	The laser light is emitted through this window.
3	Trigger Key	A trigger key used to read bar codes
4	Function Key	A function key that can be configured with application
5	LED	Indicator of operating status, such as bar code reading and warnings
6	Buzzer Hole	Sound from a built-in buzzer comes out through these holes.
7	Strap Hole	A hole to attach a hand strap
8	Battery Box Cover	A cover is opened to remove battery.

5. Electrical Specifications

5.1. USB

- Voltage : 4.5-5.5V
- Bus-Power Class : Hi-Power (500mA max)
- Current consumption : <500mA

5.2. Charging Cradle

- Voltage : 4.5-5.5V

6. Interface

The OPN-3002n supports USB, Bluetooth and serial interfaces.

6.1. USB

This interface supported FULL Speed USB.

6.1.1. Connector

Signal	Pin No.
VCC	1
Data(-)	2
Data(+)	3
(NC)	4
GND	5

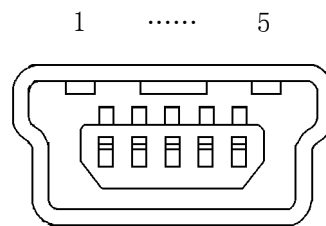

Figure 2 : MINI USB B Connector

6.1.2. USB Interface Circuit

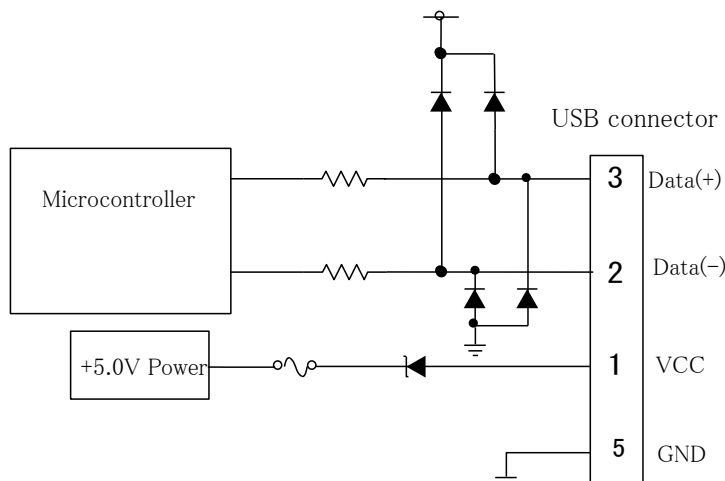

Figure 3:USBInterface Circuit

6.2. Bluetooth

The OPN-3002n supported Bluetooth.

Frequency	: 2402MHz - 2480MHz
Specification	: Bluetooth Ver2.1
Communication distance	: 10m
Output level	: Class 2 (4dBm Max. (25°C))
Supported profiles	: SPP/HID
Topology of connection	: Point-to-point
Operating mode	: Master or Slave mode
Security mode	: Enabled
Encryption	: Enabled

7. Optical Specifications

7.1. Basic Optical Specifications

Item		Characteristics
Scan method	CMOS area sensor (white / black)	-
Number of effective pixel	(Column) × (Row)	752 × 480 dots
Image capture speed (*1)	Frame rate	60 fps
Focal distance	Distance from the front edge of scanner	104 mm
View angle	Horizontal	Approx. 40.6°
	Vertical	Approx. 26.4°
Illumination light source (LED × 2)	Red LED	-
	Peak wavelength	617 nm
	Directivity angle: 2Φ 1/2 (*2)	60°
	Maximum radiation output (*3)	15000 mcd
Aiming light source	Green LED	-
	Peak wavelength	528 nm
	Maximum radiation output (*4)	18700 mcd

*1 The fastest speed of image capture

*2 Reference value extracted from the datasheet.

*3, *4 Reference value based on the datasheet (25°C, IF = 140 mA).

7.2. Aiming Pattern

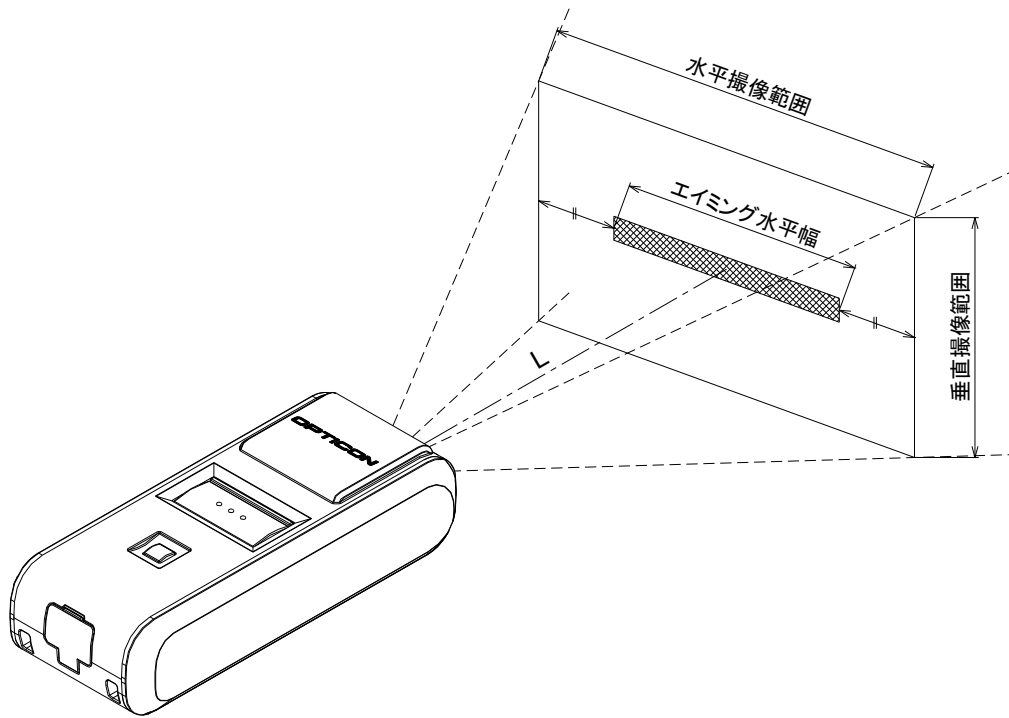

Figure 4 : Aiming Pattern and Imaging Range

7.3. Imaging Range

The range is $\pm 5\%$ from the following values.

L: Distance from the front edge of scanner	[mm]	60	80	100	120	140	160
H: Horizontal imaging range	[mm]	66	82	97	111	125	136
V: Vertical imaging range	[mm]	42	52	62	72	82	93

8. Technical Specifications

Aim the laser light at the center of a code to scan it. For long distance scanning, ambient light entering the angle of view may affect the scanning performance. The conditions for technical specifications are as follows, unless otherwise specified in each section.

<Conditions>

Ambient Temperature and Humidity	Room temperature, room humidity
Ambient Light	100 -200 lux (on the surface of a bar code)
Angles	Pitch: $\alpha = 0^\circ$, Skew: $\beta = 15^\circ$, Tilt: $\gamma = 0^\circ$
Curvature	$R = \infty$
Power Supply Voltage	3.7 V
PCS (1D and 2D)	0.9 or higher
Scanning Test	Accept the performance with 70% or more success rate for 10 tries of scan. One reading should be 2 seconds.
Barcode Test Sample (1D and 2D)	Specified below.

< Test chart >

For 1D codes, OPTOELECTRONICS test samples

For GS1 Databar, stacked codes and 2D codes, printed by a dedicated printer for bar code

8.1. Bar code Test Sample

1D Bar Codes

<Code 39>

Resolution	Symbology	PCS	Size (mm)	No. of Digits
0.127 mm (5 mil)	Code 39	0.9	32 x 10	15
0.20 mm (7.9 mil)			100 x 10	31
0.254 mm (10 mil)			32.5 x 12	7
0.508 mm (20 mil)			36 x 25	4

<Code 128>

Resolution	Symbology	PCS	Size (mm)	No. of Digits
0.20 mm (7.9 mil)	Code 128	0.9	42 x 10	16

<UPC>

Resolution	Symbology	PCS	Size (mm)	No. of Digits
0.330 mm (13 mil)	12-digit UPC	0.9/0.3	31.5 x 25.0	12

<Codabar>

Resolution	Symbology	PCS	Size (mm)	No. of Digits
0.15 mm (6 mil)	Codabar	0.9	20 x 10	10

GS1 Databar/Composite

<GS1-limited>

Resolution	Symbology	PCS	Size (mm)	No. of Digits
0.169 mm (6.7 mil)	Limited	0.9	12 x 1.5	14
0.169 mm (6.7 mil)	Limited-Composite	0.9	12 x 3.0	26

2D Codes**<PDF417>**

Resolution	Error Correction	PCS	Size (mm)	No. of Character
0.169 mm (6.7 mil)	Level-3	0.9	23 × 10	58
0.254 mm (10 mil)			35 × 15	

<QR Code: Model-2>

Resolution	Error Correction	PCS	Size (mm)	No. of Character
0.212 mm (8.4 mil)	M	0.9	6 × 6	44
0.381 mm (15 mil)			11 × 11	

<Data Matrix>

Resolution	Model	PCS	Size (mm)	No. of Character
0.212 mm (8.4 mil)	ECC200	0.9	5 × 5	40
0.254 mm (10 mil)			6 × 6	

* The size is outline dimensions excluding the quiet zones.

8.2. Scan Area and Depth of Field

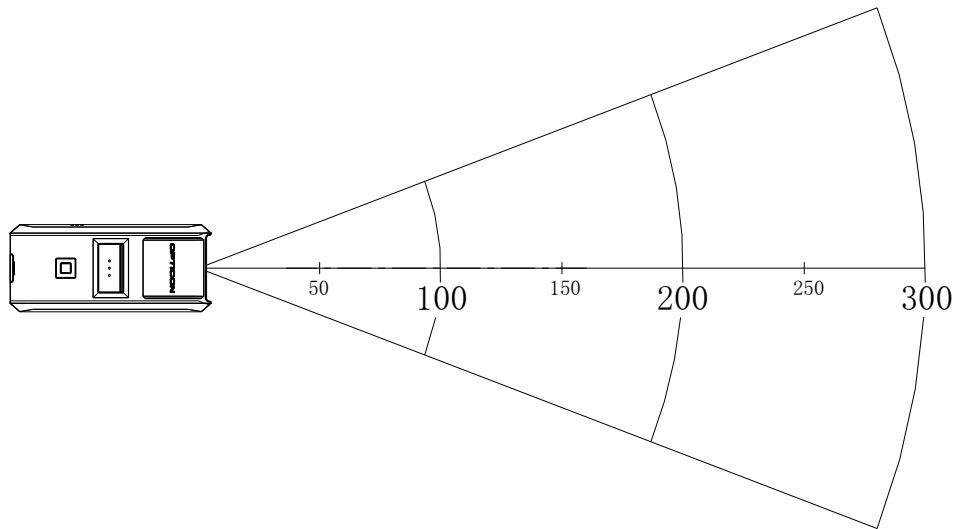

Code 39	[65	↔	0.127	↔	105	
		45	↔	0.254	↔	185	[Unit : mm]
		50	↔	:0.508	↔	250	
Code 128	[65	↔	0.20	↔	150	
UPC 100%	[45	↔	0.33	↔	175	
PDF417	[60	↔	0.169	↔	120	
		40	↔	0.254	↔	165	
QR Code	[70	↔	0.212	↔	95	
		35	↔	0.381	↔	165	
Data Matrix	[65	↔	0.254	↔	120	

Figure 5: Depth of Field

8.3. Printed Contrast Signal (PCS)

0.3 or higher

<Conditions>

- MRD : 32% and higher
(70% or higher reflectivity of space and quiet zone)
- Distance : 105mm from the front edge of the scanner
- Bar Code Sample : UPC specified in Chapter 8. (Resolution: 0.33 mm, PCS: 0.3)
- MRD = Minimum reflectance of white bar - Maximum reflectance of black bar

$$PCS = \frac{\text{Reflectance of white bar} - \text{Reflectance of black bar}}{\text{Reflectance of white bar}}$$

8.4. Minimum Resolution

1D Code	: 0.127 mm (5 mil)	Code 39 specified in Chapter 8.1
GS1-Databar	: 0.169 mm (6.7 mil)	GS1 Databar Limited specified in Chapter 8.1
Stacked Code	: 0.169 mm (6.7 mil)	PDF417, GS1 Databar Limited Composite specified in Chapter 7.1
2D Code	: 0.212 mm (8.4 mil)	QR Code and Data Matrix specified in Chapter 8.1

<Conditions>

Bar Code Sample	: The above codes specified in Chapter 8.1
Distance	: 75 mm from the front edge of the scanner
Angle	: $\alpha = 0^\circ$, $\beta = +15^\circ$, $\gamma = 0^\circ$
Curvature	: $R = \infty$

8.5. Wide Barcode

Code 39 with width of 100 mm and resolution of 0.2 mm can be read

<Conditions>

Bar Code Sample	: 0.20 mm Code 39 / PCS 0.9 specified in Chapter 8.1
Distance	: 135 mm from the front edge of the scanner
Angle	: $\alpha = 0^\circ$, $\beta = +15^\circ$, $\gamma = 0^\circ$
Curvature	: $R = \infty$

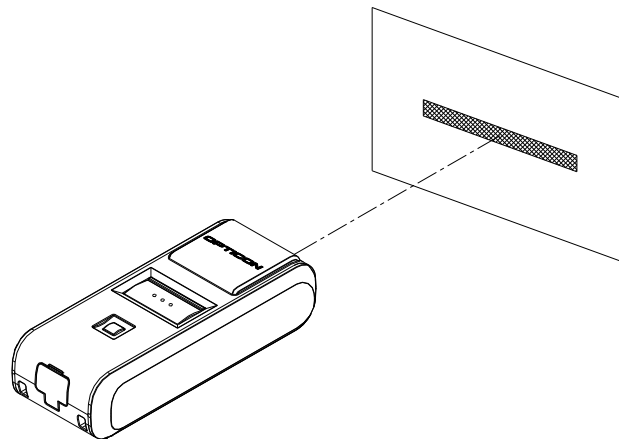

Figure 6 : Wide Barcode

8.6. Pitch, Skew and Tilt

Pitch	: $\alpha = \pm 50^\circ$
Skew	: $\beta = \pm 50^\circ$
Tilt	: $\gamma = \pm 180^\circ$

<Conditions>

Bar Code Sample	: 0.33 mm UPC specified in Chapter 7.1
Distance	: 105 mm from the front edge of the scanner
Curvature	: $R = \infty$

* For the pitch angle and tilt angle measurement, set the skew angle $\beta = +15^\circ$

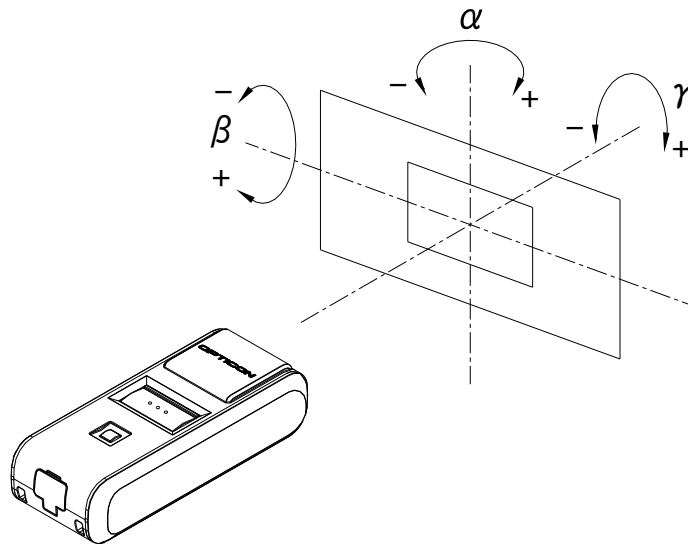

Figure 7 : Pitch, Skew and Tilt

8.7. Curvature

- 0.33 mm 12-digit UPC : $R \geq 20 \text{ mm}$
- 0.15 mm 10-digit Codabar : $R \geq 16 \text{ mm}$

<Conditions>

- Bar Code Sample : 0.33 mm UPC, 0.15 mm Codabar specified in Chapter 7.1
- Distance : 85 mm from the front edge of the scanner
- Angle : $\alpha = 0^\circ, \beta = +15^\circ, \gamma = 0^\circ$

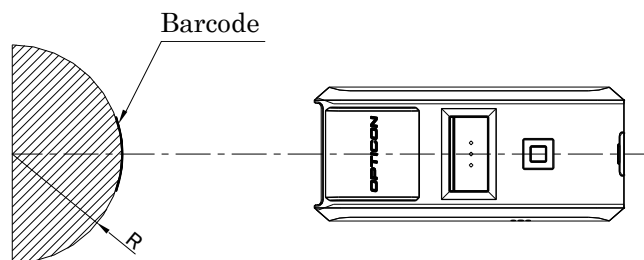

Figure 8 : Curvature

Note: Scanning may fail due to the specular reflection of LED illumination when the reflectivity is high.

9. Environmental Specifications

9.1. Temperature

Operating : 0 - 50 °C
 Storage : -20 - 60 °C

9.2. Humidity

Operating : 20 - 85%RH (no condensation, no frost)
 Storage : 20 - 85%RH (no condensation, no frost)

9.3. Ambient Light Immunity

Scanning performance is guaranteed when the range of illumination on a barcode surface is the following values.

Incandescent light : 0 - 10,000 lx
Fluorescent light : 0 - 10,000 lx
Sunlight : 0 - 100,000 lx

<Conditions>

Bar Code Sample : 0.33 mm UPC specified in Chapter 7.1
Distance : 100 mm from the front edge of the camera module
Angle : $\alpha = 0^\circ$, $\beta = +15^\circ$, $\gamma = 0^\circ$
Curvature : $R = \infty$
Power Supply Voltage : 3.7 V

*** Be sure that the direct light or specular reflection from the light source does not enter the light receiving section of the OPN-3002n.**

9.4. Dust and Drip Proof

IEC IP42 equivalent

Protection against solid objects: Level 4

Protected against solid objects greater than 1.0 mm

Protection against liquids: Level 2 (JIS IPX2)

Protected against dripping water from the vertical when tilted up to 15°

9.5. Vibration Strength(without packing)

There shall be no sign of malfunction after the following vibration test.

Vibration test: Increase the frequency of the vibration from 10Hz to 100Hz at an accelerated velocity of 19.6m/s² (2.0 G) for 30 minutes (60 minutes for a cycle) in the non-operating state. Repeat this in each X, Y and Z direction.

9.6. Vibration Strength (in individual packing)

There shall be no sign of malfunction after the following vibration test.

Vibration test: Increase the frequency of the vibration from 10Hz to 100Hz at an accelerated velocity of 19.6 m/s² (2.0 G) for 30 minutes (60 minutes for a cycle) in individually packaged state. Repeat this in each X, Y and Z direction.

9.7. Drop Impact Strength

There shall be no sign of malfunction after the following drop test.

Drop test: Drop the scanner three times (18 times in total), at each 6 face, from a height of 150cm onto a concrete floor as shown below.

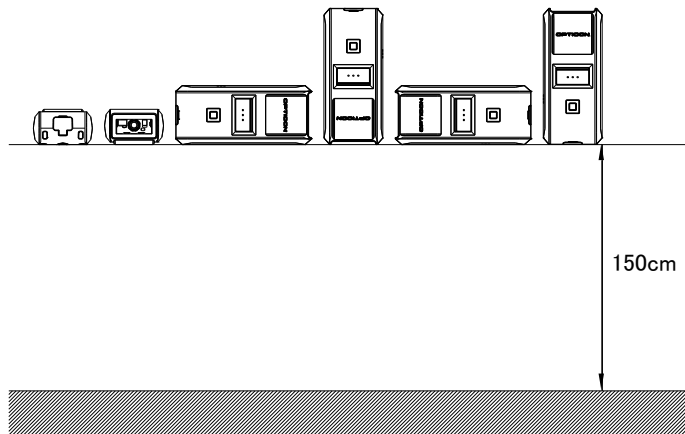

Figure 9: Drop test

9.8. Drop Impact Strength (in individual packaging)

There shall be no sign of malfunction after the following drop test.

Drop test: Drop an individually packaged scanner 10 times in total, at any of 1 corner, 3 edges, and 6 faces, from a height of 150 cm onto a concrete floor.

9.9. Electrical Specifications

Air discharge	±8 kV max. (No malfunction) ±15 kV max. (No destruction)
Measurement environment	An electrostatic testing device compliant with IEC 61000-4-2 is used.
Discharge resistance	330 Ω
Charging capacitor	150 pF

10. Regulatory Compliance

10.1. LED Safety

IEC 62471-1:2006 Exempt Risk Group

10.2. Product Safety

EN60950-1:2005

IEC60950-1:2006

10.3. EMC

EN55022

EN55024

FCC Part 15 Subpart C , Subpart B ClassB

Federal Communications Commission Notices

This product complies with Part 15 of the FCC Rules. Operation is subject to the following two conditions:

- (1) this device may not cause harmful interference, and
- (2) this device must accept any interference received, including interference that may cause undesired operation.

Harmful Interference Notice

This product has been tested and complies with the specifications for a Class B digital device, pursuant to Part 15 of the FCC Rules. These limits are designed to provide reasonable protection against harmful interference in a residential installation. This equipment generates, uses, and can radiate radio frequency energy and, if not installed and used according to the instructions, may cause harmful interference to radio communications. However, there is no guarantee that interference will not occur in a particular installation. If this equipment does cause harmful interference to radio or television reception, which is found by turning the equipment off and on, the user is encouraged to try to correct the interference by one or more of the following measures:

- Reorient or relocate the receiving antenna
- Increase the separation between the equipment or devices
- Connect the equipment to an outlet other than the receiver's
- Consult a dealer or an experienced radio/TV technician for assistance

Changes or modifications to this equipment that have not been approved by Ruckus Wireless may void the user's authority to operate this equipment.

RF Exposure

The OPN-2002n unit (FCC ID: UFOOPN2002n) complies with FCC radiation exposure limits set forth for uncontrolled environment and meets the FCC radio frequency (RF) Exposure Guidelines in Supplement C to OET65. The unit has very low level of RF energy that it is deemed to comply without testing of specific absorption ratio (SAR).

VCCI Class B

This is a Class B product, to be used in a domestic environment, based on the Technical Requirement of the Voluntary Control Council for Interference from Information Technology Equipment (VCCI). If this is used near a radio or television receiver in a domestic environment, it may cause radio interference.

10.4. Other

Bluetooth logo certification

MFi License Program

The OPN-3002n uses Bluetooth module which qualifies as radio equipment for low-power radio stations as specified in the Radio Law 38-24-1.

Specified Radio Equipment:

Low power data communications system in the 2.4GHz band in Article 2 paragraph 1 item (19), Ordinance of MPT.

Model type of Bluetooth module: OPA-26X1

Number of certification: 201-125603

11. RoHS

The OPN-3002n is compliant with RoHS.

RoHS: The restriction of the use of certain hazardous substances in electrical and electronic equipment, 2002/95/EC

12. MTBF

MTBF (Mean Time Between Failures) 10,000 hours

13. Precautions

13.1. Precaution against Laser Light

***Use of controls or adjustments or performance of procedures other than those specified herein may result in hazardous radiation exposure.**

Caution - Do not stare into the laser light from a scanning window. It may harm your eyes.

Do not point the laser directly at others' eyes. It may harm your eyes.

Do not stare into the beam with optical instruments. It may harm your eyes.

13.2. Handling

Handle this product carefully. Do not deliberately subject it to any of the following:

(1) Shock:

- Do not drop this product from a height greater than specified in this manual.
- Do not place this product under or between any heavy items.
- Do not swing this product around holding the hand strap.

(2) Temperature Conditions:

- Do not use this product at temperatures outside the specified range.
- Do not pour boiling water on this product.
- Do not throw this product into a fire.

(3) Foreign Materials:

- Do not immerse this product in water or other liquid.
- Do not expose this product to chemicals.

(4) Others

- Do not disassemble this product.
- Do not use this product near a radio or a TV. It may cause reception problems.
- This product may be affected by a momentary voltage drop caused by lightning.
- This product may not perform properly in a place where it will be subjected to a flickering light, such as a CRT (computer monitor, television, etc.).

13.3. Radio Low

The OPN-3002n uses Bluetooth module which qualifies as radio equipment for low-power radio stations (2.4 GHz band advanced data communication systems) as specified in the Radio Law 38-24-1.

Therefore it does not need to have a radio station license in Japan.

The following activities are prohibited under the Radio Law:

- Remodeling and disassembly
- Peeling off the certificate label

Do NOT use the scanner under the following environment, as radio interference may affect other device and end up with causing physical or material damage.

- Safety apparatus and medical device for human body protection
- Environment where is concerned to cause serious damage

13.4. Export Administration Regulations

This product is subject to the strategically controlled exports regulated under "Foreign Exchange and Foreign Trade Laws". Therefore, **export of this product may require an export permission of Japanese government.**

13.5. Bluetooth

To communicate via Bluetooth, the device which OPN-3002n is connected to must support the same Bluetooth version and profile as OPN-3002n's.

- OPN-3002n is compliant to Bluetooth standards. However, we cannot assure the connection between OPN-3002n and other Bluetooth devices which have not been tested.
- Bluetooth supporting devices use 2.4 GHz frequency band. However, many other sorts of devices also utilize this frequency band. It may have an effect on the communication speed or communication range of this data collector.
- The use of OPN-3002n outside of the European Union, the United States and Canada is punishable under the law.
- Communication speed and communication range of OPN-3002n may differ due to the obstacles and radio wave conditions between OPN-3002n and the device, which OPN-3002n is connected to.
- Conditions of the device, which OPN-3002n is connected to, may also affect the communication speed and communication range of OPN-3002n.

13.6. Frequency Band

The frequency band 2.4 GHz is utilized by this product. Read carefully the followings before using this product.

In the frequency band of this product, scientific, medical and industrial devices including microwaves are used. Also other radio stations including local private radio station for mobile object identification requiring

license for such as manufacturing lines at factories, specific power-saving radio station requiring no license and amateur radio station are managed.

1. Please make sure that “other radio stations” are not managed in the frequency band 2.4 GHz before using this product.
2. In case that radio interference occurs between this product and “other radio stations,” change the service space immediately, or stop transmitting radio wave to avoid the interference.
3. If you have any questions or troubles, please contact our sales office.

*** This specification manual is subject to change without prior notice.**

14. Product Label

The labels shown below are attached to the back side of the data collector.

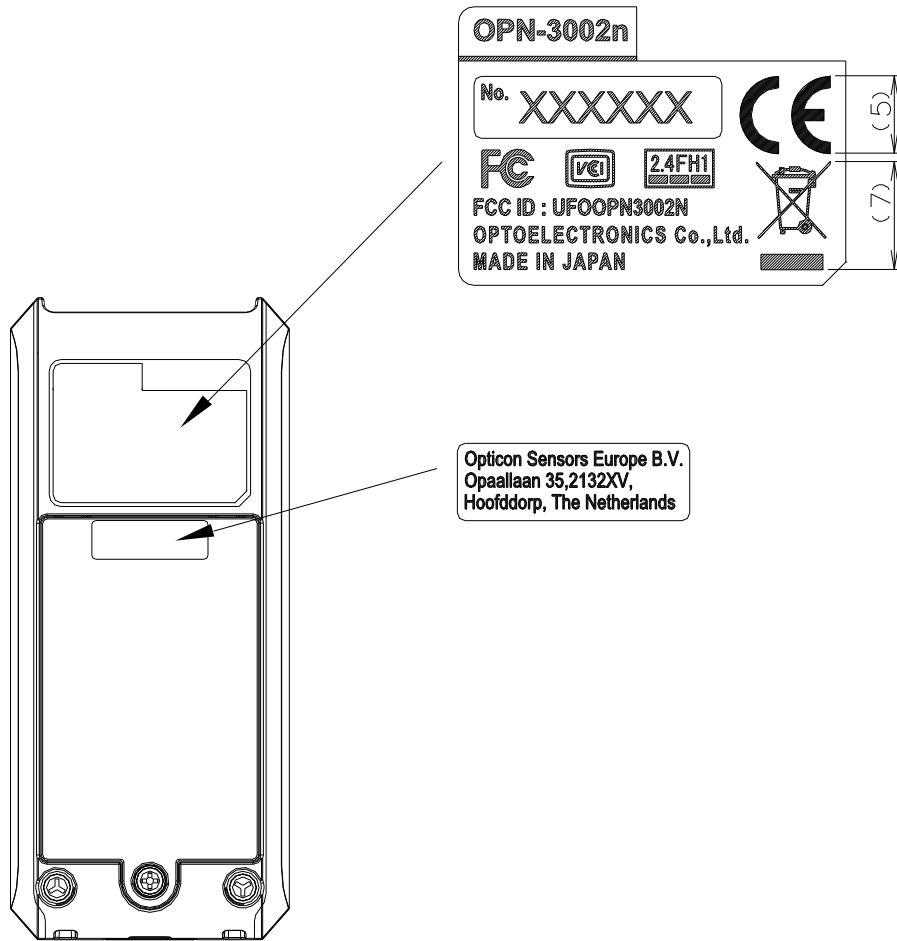

Figure 10: Product & Laser Caution Label

15. Packaging Specifications

15.1. Individual Packaging Specification

Assembled package size: 125 x 112 x 40 (WDH mm)

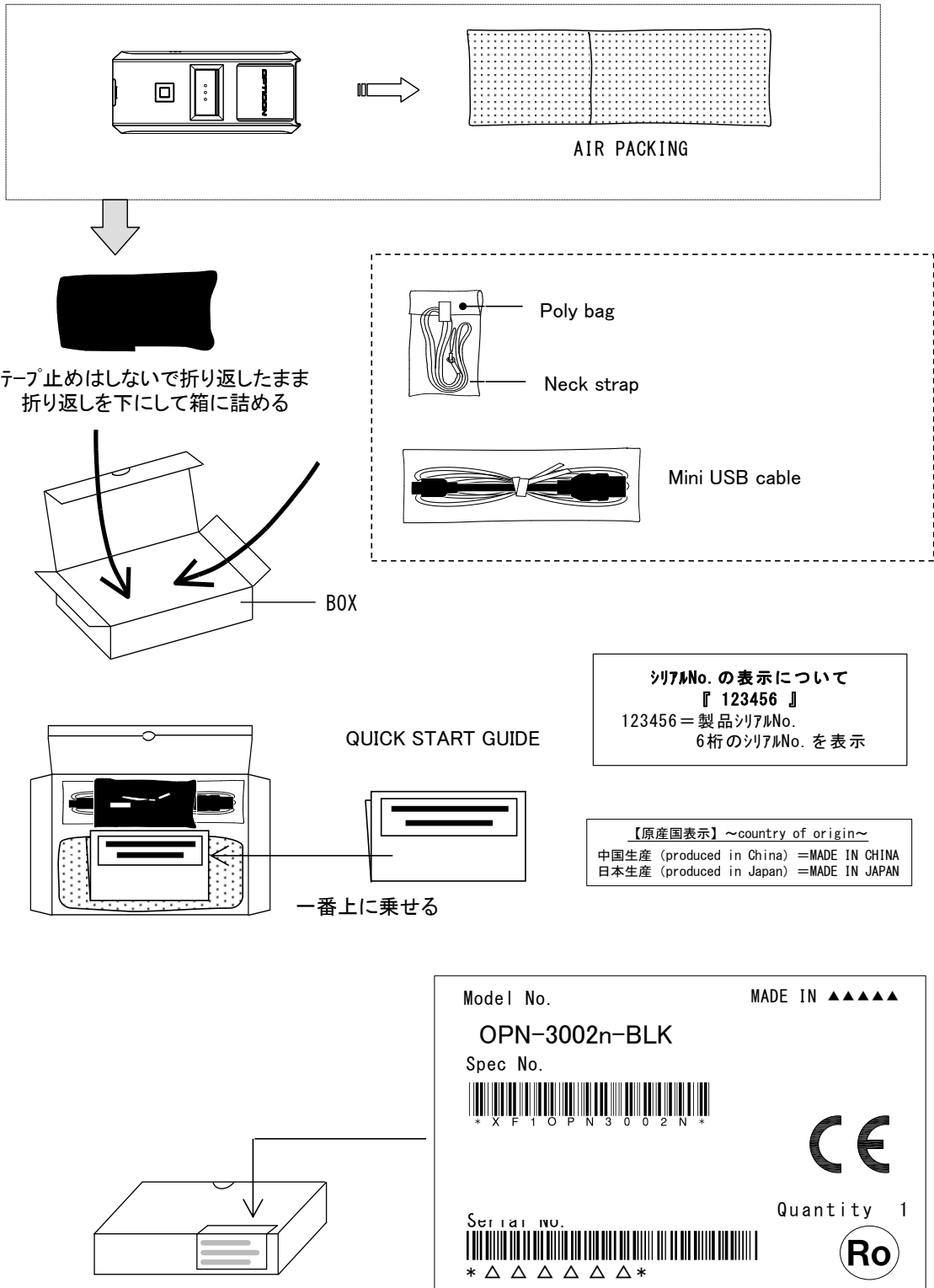
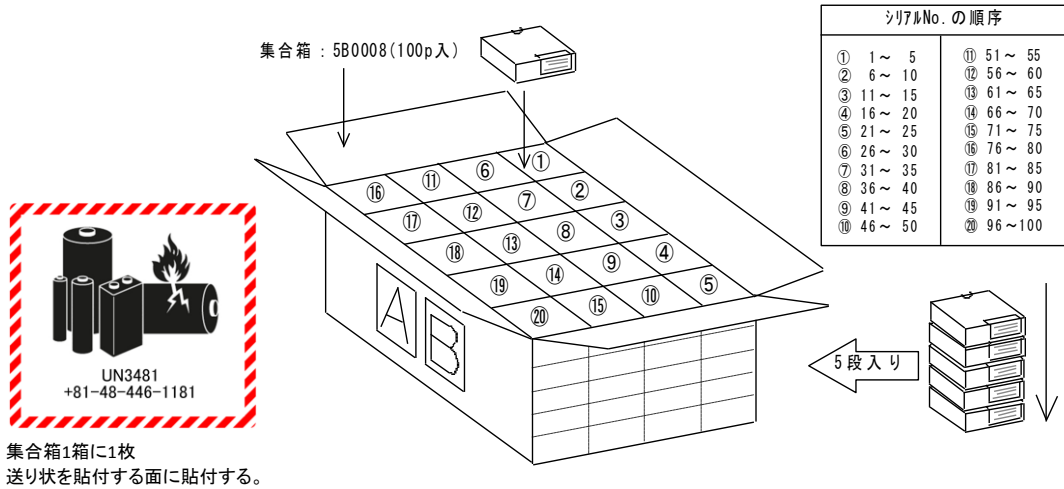

Figure 11: Individual Packaging

15.2. Collective Packaging Specification

Assembled package size: 595 x 520 x 245 (WDH mm), 100 pieces/box



A : 外装箱バーコードラベル
正面と背面の2ヶ所に貼付(面の中央付近)

B : Missing Serial Numberラベル
欠品が3つ以上の場合にのみ貼付する
Aラベルと並べ正面と背面の2ヶ所に貼付(面の中央付近)

(3C0006)

(3C0007)

C/No. $\triangle \triangle$
MADE IN $\triangle \triangle \triangle \triangle$

Product OPN-3002i-WHT

P0#

Spec#JPN

Q'ty S/N (from)

$\triangle \triangle / \triangle \triangle \triangle$ S/N (to)

Missing Serial Number	Missing Q'ty \triangle
1	
2	

ROM Ver. (MAIN) TC02JXX
ROM Ver. (Bluetooth) TD01JXX
ROM Ver. (Module CPU) BA01JXX
ROM Ver. (Module Sub CPU) BC01JXX

Shipping Date 20 $\triangle \triangle / \triangle \triangle / \triangle \triangle$
OPTOELECTRONICS CO., LTD.

C/No. $\triangle \triangle$
MADE IN $\triangle \triangle \triangle \triangle$

Missing Serial Number	Missing Q'ty $\triangle \triangle$
3	
4	
5	
6	
7	
8	
9	
10	
11	
12	

OPTOELECTRONICS CO., LTD.

【原産国表示】 ~country of origin~
中国生産 (produced in China) =MADE IN CHINA 日本生産 (produced in Japan) =MADE IN JAPAN

Figure 12: Collective Packaging

16. Warranty

16.1. Warranty period

OPTOELECTRONICS Co., Ltd. warrants that this product is free of defects or malfunctions for a period of twelve (12) months from its shipment. In case of having defects or malfunctions caused by normal usage in accordance with this specification during the foregoing warranty period, OPTOELECTRONICS shall repair or adjust the product free of charge.

Any repair or replacement of the product after the foregoing warranty period shall be charged at regular repair rates.

If defects or malfunctions were caused by customer mishandling, product repairs or replacement will be charged at regular repair rates, even during the foregoing warranty period.

16.2. Delivery

Products for maintenance or repair shall be sent back to OPTOELECTRONICS. The sender is responsible for all shipping costs.

16.3. Repair Timeframe

Repaired products shall be shipped back to the customer within 20 days after acceptance by OPTOELECTRONICS.

Expedited repairs may be available, subject to terms agreed to by OPTOELECTRONICS and the customer.

16.4. Maintenance Period

The maintenance period of this product is 5 years after its shipment.

OPTOELECTRONICS may discontinue maintenance for this product during the 5-year maintenance period if a satisfactory replacement product or maintenance solution is agreed to.

16.5. Other

Any additional warranty issues must be discussed with OPTOELECTRONICS on a case-by-case basis.

17. Physical Features

17.1. Dimensions

83.0(D) × 36.0(W) × 21.5(H) (mm)

17.2. Weight

Approx. 57g (Excluding the accessories)

17.3. Mechanical Drawing

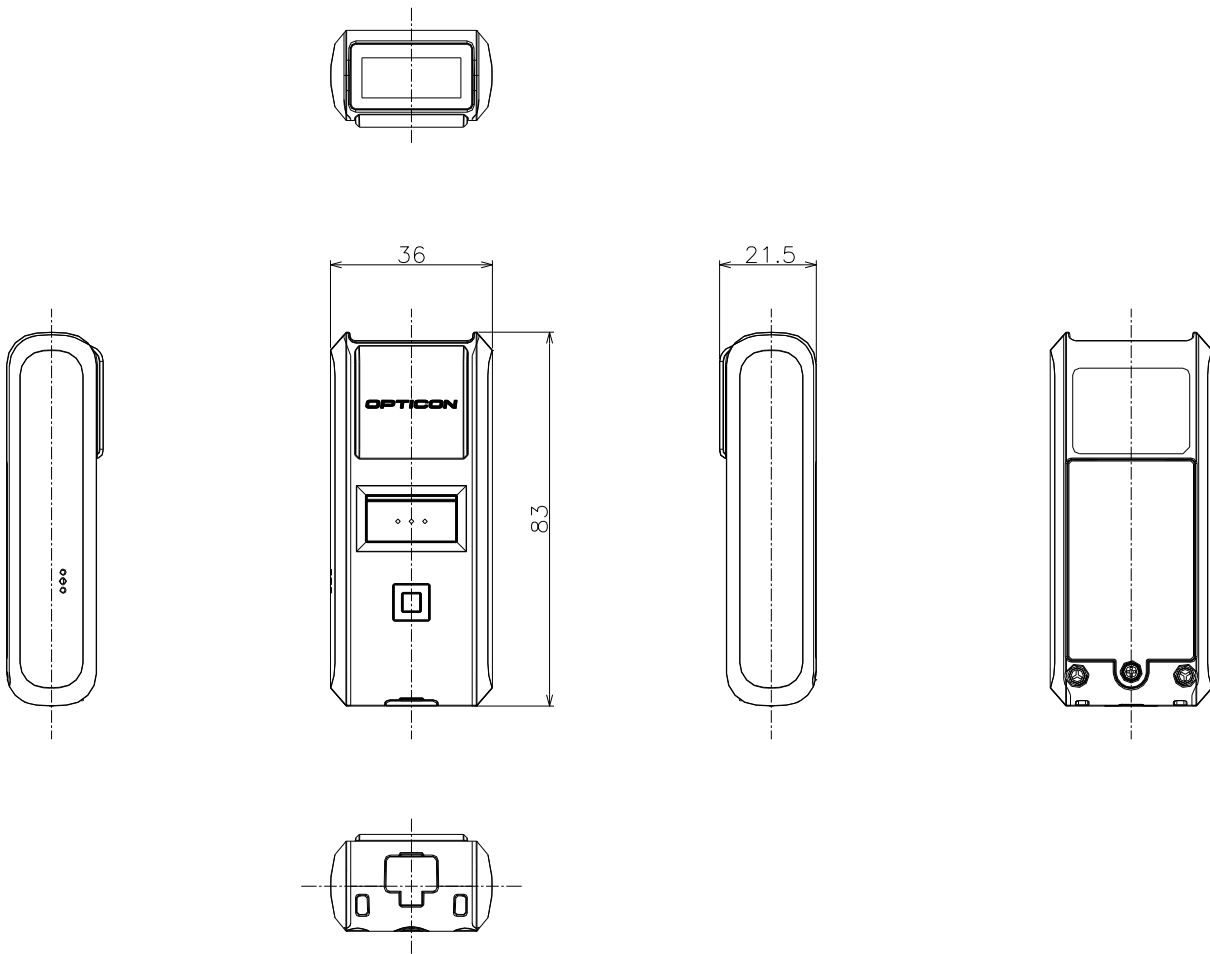
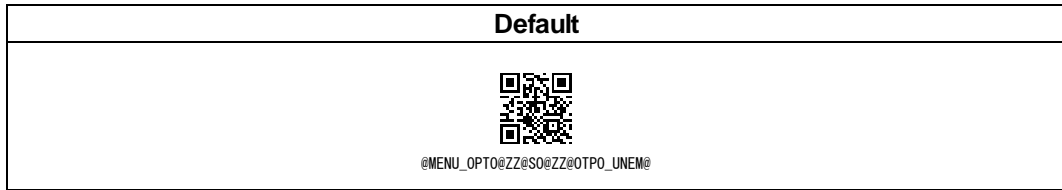

Figure 13: Mechanical Drawing

18. Supported Symbologies

The OPN-3002n is set to default settings by reading the following menu label regardless of the interface types.



18.1. 1D symbologies

Code type	Default	Minimum length	Remarks
UPC	○	-	
UPC Add-on 2			
UPC Add-on 5			
EAN(JAN)	○	-	
EAN Add-on 2			
EAN Add-on 5			
EAN-13	○		
EAN-13 Add-on 2			
EAN-13 Add-on 5			
EAN-8	○		
EAN-8 Add-on 2			
EAN-8 Add-on 5			
Code 39	○	1	Not transmit ST/SP
Tri-Optic	○	-	Not transmit ST/SP
Codabar (NW7)	○	1	Not transmit ST/SP
Industrial 2 of 5	○	5	
Interleaved 2 of 5	○	6	
S-Code		5	
Code 128	○	1	GS1 conversion (setting required)
Code 93	○	1	
IATA	○	5	
MSI/Plessey		3	
UK/Plessey		2	
Telepen		1	
Code 11		1	
Matrix 2 of 5		5	
Chinese Post Matrix 2 of 5		-	
Korean Postal Authority		-	
Intelligent Mail Barcode		-	
POSTNET		-	
JPN (Customer Bar Code)		-	

18.2. GS1 Databar, Composite Code

Code type	Default	Remarks
GS1 DataBar ·GS1 DataBar Omnidirectional ·GS1 DataBar Truncated ·GS1 DataBar Stacked ·GS1 DataBar Stacked Omnidirectional	○	GS1 conversion (setting required)
GS1 DataBar Limited	○	
GS1 DataBar Expanded ·GS1 DataBar Expanded ·GS1 DataBar Expanded Stacked	○	
Composite GS1 DataBar ·CC-A ·CC-B ·Limited CC-A ·Limited CC-B ·Expanded CC-A ·Expanded CC-B		GS1 conversion (setting required)
Composite GS1-128 ·CC-A ·CC-B ·CC-C		GS1 conversion (setting required)
Composite EAN ·EAN-13 CC-A ·EAN-13 CC-B ·EAN-8 CC-A ·EAN-8 CC-B		GS1 conversion (setting required)
Composite UPC ·UPC-A CC-A ·UPC-A CC-B ·UPC-E CC-A ·UPC-E CC-B		GS1 conversion (setting required)

18.3. 2D codes

Code type	Default	Remarks
PDF417	○	
Micro PDF417		
Codablock F		
QR Code	○	GS1 conversion (setting required)
Micro QR	○	
Data Matrix (ECC 200)	○	GS1 conversion (setting required)
Data Matrix (ECC 000-140)		
Aztec Code	○	
Aztec Runes		
Chinese-sensible code		
Maxi Code		