

OPTICON

Handheld Bluetooth 1D CCD Scanner

OPC-3301i



This manual provides specifications for the OPC-3301i handheld Bluetooth 1D CCD scanner.

Specifications Manual

All information subject to change without notice.

Document History

Model Number:	OPC-3301i	Specification Number:	SS14062
Edition:	2nd	Original Spec Number:	SS14018
Date:	2015-07-24		

Copyright 2015 Opticon. All rights reserved.

This manual may not, in whole or in part, be copied, photocopied, reproduced, translated or converted to any electronic or machine readable form without prior written consent of Opticon.

Limited Warranty and Disclaimers

PLEASE READ THIS MANUAL CAREFULLY BEFORE INSTALLING OR USING THE PRODUCT.

Serial Number

A serial number appears on all Opticon products. This official registration number is directly related to the device purchased. Do not remove the serial number from your Opticon device. Removing the serial number voids the warranty.

Warranty

Unless otherwise agreed in a written contract, all Opticon products are warranted against defects in materials and workmanship for two years after purchase. Opticon will repair or, at its option, replace products that are defective in materials or workmanship with proper use during the warranty period. Opticon is not liable for damages caused by modifications made by a customer. In such cases, standard repair charges will apply. If a product is returned under warranty and no defect is found, standard repair charges will apply. Opticon assumes no liability for any direct, indirect, consequential or incidental damages arising out of use or inability to use both the hardware and software, even if Opticon has been informed about the possibility of such damages.

Packaging

The packing materials are recyclable. We recommend that you save all packing material to use should you need to transport your scanner or send it for service. Damage caused by improper packaging during shipment is not covered by the warranty.

Trademarks

Trademarks used are the property of their respective owners.

Opticon Inc. and Opticon Sensors Europe B.V. are wholly owned subsidiaries of OPTOELECTRONICS Co., Ltd., 12-17, Tsukagoshi 4-chome, Warabi-shi, Saitama, Japan 335-0002. TEL +81-(0) 48-446-1183; FAX +81-(0) 48-446-1184

SUPPORT

USA

Phone: 800-636-0090

Email: support@opticonusa.com

Web: www.opticonusa.com

Europe

Email: support@opticon.com

Web: www.opticon.com

Revision History

Specification No. : SS14062
Product name : OPC-3301i

Edition	Date	Page	Section	Description of Changes
First	2014/11/26	-	-	Initial release
Second	2015/07/16	1	2	Deleted: Vibration, Antimicrobial
		2	3	Deleted: Vibration motor
				Corrected: Wide bar code 150mm -> 127mm
				Added: PCS to Note
		3	3	Added: PCS to Depth of field Note
				Corrected: IEC 62471-1:2006 -> IEC 62471:2006
		5	5.1	Corrected: EN60950-1:2005 -> EN60950-1:2006 IEC60950-1:2006 -> IEC60950-1:2005
		6	7.1.	Deleted: "vibration motor activated" from Operating
		15	10.1.	Corrected: IIEC 62471-1:2006 -> IEC 62471:2006
				Corrected: EN60950-1:2005 -> EN60950-1:2006 IEC60950-1:2006 -> IEC60950-1:2005
Added: FCC Part 15 Subpart C, Subpart B ClassB RF Exposure Information.				
18	14.	Changed: Logo label (FCC logo deleted)		

Contents

1. Abstract.....	1
2. Overview	1
3. Basic Specifications	2
4. Detailed View	4
5. Electrical Specifications	5
5.1. Current Consumption	5
5.2. Operating Time and Charging Time	5
6. Interface Specifications	5
6.1. Bluetooth	5
7. Optical Specifications.....	6
7.1. Basic Optical Specifications	6
7.2. Aiming Pattern.....	6
8. Technical Specifications	7
8.1. Bar Code Test Sample	7
8.2. Scan Area and Depth of Field	8
8.3. Printed Contrast Signal (PCS).....	9
8.4. Minimum Resolution	9
8.5. Wide Bar Code	9
8.6. Pitch, Skew and Tilt.....	10
8.7. Curvature.....	10
8.8. Scanning from LCD Screen.....	11
8.9. Auto Trigger.....	11
8.9.1. Stand Detection.....	11
8.9.2. Auto Trigger Operation.....	12
9. Environmental Specifications	13
9.1. Temperature	13
9.2. Humidity	13
9.3. Ambient Light Immunity.....	13
9.4. Dust and Drip Proof.....	13
9.5. Vibration Strength (without packing).....	13
9.6. Vibration Strength (in individual packing)	14
9.7. Drop Impact Strength (without packaging)	14
9.8. Drop Impact Strength (in individual packaging).....	14
9.9. Electrostatic Discharge (ESD) Immunity	14
10. Regulatory Compliance	15

10.1. LED Safety	15
10.2. Product Safety	15
10.3. EMC	15
10.4. Others.....	16
11. RoHS.....	16
12. Reliability	16
13. Precautions.....	16
13.1. Handling	16
13.2. Radio Law	17
13.3. Bluetooth	17
13.4. Frequency Baud	17
14. Product Labels	18
15. Packaging Specifications	19
15.1. Individual Packaging	19
15.2. Collective Packaging	20
16. Physical Features.....	21
16.1. Dimensions.....	21
16.2. Weight	21
16.3. Mechanical Drawing	21
17. Supported Symbologies	22
17.1. Default Setting	22
17.2. Supported Symbologies	22
17.2.1. 1D Bar Codes	22
17.2.2. GS1 Databar, Composite Code.....	23

1. Abstract

This manual provides specifications for the OPC-3301i handheld Bluetooth 1D CCD scanner.

2. Overview

The OPC-3301i is a handheld 1D scanner with a built-in CCD imager that enables high speed scanning of standard linear (1D) symbologies. The scanned data is output via Bluetooth.

- All bar code data scanned is transmitted to a host device through the Bluetooth interface.
- The scanner can work with many Bluetooth-enabled host devices, such as PCs, tablet PCs and smart phones.
- Bluetooth SPP (Serial Port Profile) and HID (Human Interface Device Profile) are implemented.
- The scanner can read bar codes from LCD screens.
- A single red LED aiming line toward a target bar code can help the users find the appropriate scanning position.
- The power source is 3.7 V 1100 mAh (typ.) lithium-ion battery.
- A dedicated charging cradle CHG-3201 is supplied for recharging and easy storage of the scanner.
- The scanner is Apple MFi certified.

3. Basic Specifications

Item		Specification		Note		
Control Section	CPU	32 bit CISC / 96 MHz				
	FROM	512 Kbyte + 32 Kbyte				
	SRAM	96 Kbyte				
	FROM (storage)	1 Mbyte		For data area only		
Input Section	Key type	1 key: trigger				
	Indicator	LED	2 colors (red, green) and 1 color (blue)			
Buzzer		Loudness (3-level) / tone adjustable				
Interface	Bluetooth	Frequency	2402 ~ 2480 MHz			
		Specification	Bluetooth Ver 2.1 compliant			
		Communication distance	10 m		It may be shorter depending on usage environments	
		Output level	Class 2		Max output 4 dBm	
		Profile	SPP / HID			
Optical Section	Scan method	CCD linear image sensor				
	Light source	1 red LED				
	Effective pixels	1500 pixels				
	View angle	Horizontal: approx. 50°				
Supported 1D Symbologies	Symbologies	JAN, EAN, UPC-A, UPC-E, NW-7 (Codabar), Industrial 2 of 5, Interleaved 2 of 5, Code 11, Code 39, Code 93, Code 128 etc.		Refer to Chapter 17. for details		
	Minimum resolution	Code 39 : 0.1 mm		PCS 0.9		
	Curvature	R ≥ 15 mm (8-digit JAN) R ≥ 20 mm (13-digit JAN)		PCS 0.9		
	Wide bar code	110 mm wide 0.2 mm resolution Code 39 (DOF 127 mm) is readable:		PCS 0.9		
	Scan angle	Pitch : ±50°				
		Skew : ±65° (excluding dead zone)				
		Tilt : ±25°				
	Depth of field (mm)	Code 39	Resolution (0.127)	55 ~ 75		PCS 0.9
			Resolution (0.15)	45 ~ 100		
			Resolution (0.25)	35 ~ 175		
Resolution (0.5)			40 ~ 300			
Resolution (1.0)			60 ~ 500			
Minimum PCS	0.3 or more		MRD 32% or more			

Item		Specification		Note
	On LCD screen	Brightness of white space	30 cd/m ² or more	
		Contrast ratio	100:1 or more	
Power Section	Main battery		Lithium-ion 1100 mAh (typ.)	Charge the battery before initial use
	Up-time		48 hours or more	*1
	Operating (charging) voltage		5.0 ~ 6.5V	Charging with charger
	Current consumption	Charging	Less than 1 A	
Environmental Specifications	Temperature	Operating	0 ~ 50°C	
		Storage	-20 ~ 60°C	
	Humidity	Operating	20 ~ 85%	No condensing No frost
		Storage	20 ~ 85%	
	Ambient light immunity	Fluorescent	10,000 lx or less	
		Sunlight	100,000 lx or less	
	Vibration		10 Hz ~ 100 Hz, acceleration of 19.6 m/s ² , 60 minutes per cycle, repeat once in each X, Y and Z-direction	
	Drop		Drop the scanner 30 times (6 faces x 5) from the height of 150 cm onto a concrete floor	
Dust and drip proof		IP42 equivalent		
Regulatory Compliance	LED safety		IEC 62471:2006 Exempt_Group	Peak Wavelength 624 nm
	Product safety		EN60950-1:2006 IEC60950-1:2005	
	EMC		EN 55022:2010 EN 301 489-1 V1.9.2 EN 301 489-17 V2.1.1 EN 300 328 V1.8.1 FCC Part 15 Subpart C, Subpart B ClassB VCCI Class B	For residential, commercial and light-industrial environments
	Other		Bluetooth logo certification MFi license CE Marking Certification for Construction Design of Specified Radio Equipment	
Immunity Test	ESD	No distraction	Air discharge (direct): ±15 kV	Conditions: IEC61000-4-2 compliant
		No malfunction	Contact discharge (direct / indirect): ±6 kV Air discharge (direct): ±8 kV	
Physical Features	Dimensions		113 × 56 × 132 (WDH mm)	
	Weight		Approx. 127 g	Excluding accessories

*1: When a bar code is read twice every 10 seconds at room temperature in a const Bluetooth connection (SPP master mode).

4. Detailed View

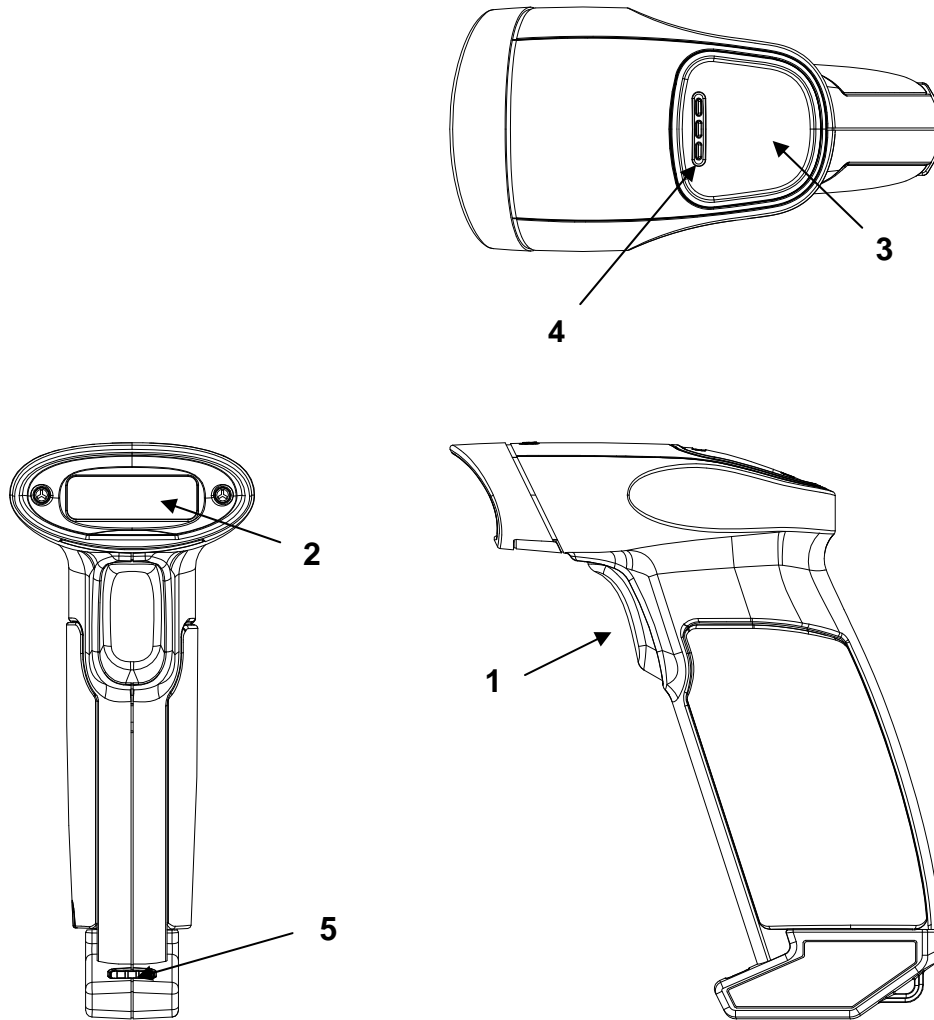

Figure 1: Detailed View of OPC-3301i

No	Name	Description
1	Trigger Key	A key to read bar codes
2	Scan Window	LED illumination is emitted from this window to read bar codes.
3	Status LED	The operating statuses, such as bar code reading, Bluetooth connection and warning, are indicated by different colors.
4	Buzzer Holes	A sound from a built-in buzzer comes out through these holes.
5	Charging terminals	Charging pins connected to the dedicated charging cradle CHG-3201

5. Electrical Specifications

5.1. Current Consumption

Item	Specification	Note
Standby	15 mA or less	With wireless connection
Sleep	1 mA or less	
Operating	200 mA or less	Reading, communications, LED
Measurement condition	Power voltage 3.7 V at 25 °C	

5.2. Operating Time and Charging Time

Item	Specification	Note	
Battery duration	Sleep	200 hours or more	
	Standby	Approx. 72 hours	With wireless connection
	Reading	Approx. 48 hours	1 scan / 5 secs with wireless connection
Charging time	Approx. 3 hours	With AC adaptor power supply	

* The above specifications may not be met when the battery pack has been deteriorated.

6. Interface Specifications

6.1. Bluetooth

Frequency	: 2402 ~ 2480 MHz
Specification	: Bluetooth Ver 2.1 compliant
Communication distance	: 10 m
Output level	: Class 2 (max 4 dBm)
Implemented profile	: SPP / HID
Communication configuration	: 1 to 1
Operating mode in communication	: Master / Slave mode
Security mode	: Authentication supported
Encryption	: Encryption supported

7. Optical Specifications

7.1. Basic Optical Specifications

Item		Characteristics
Scan method	CCD linear image sensor	-
Effective pixel	Horizontal	1500 dots
Image capture speed (*1)	Scan rate	300 scans/sec
Focal distance	Distance from the front edge of scanner	82 mm
View angle	Horizontal	Approx. 50°
Light source	Red LED	-
	Peak wavelength	624 nm
	Maximum radiation output (*2)	12 lm

*1 The fastest speed of image capture

*2 Reference value based on the datasheet (25°C, luminous efficiency 60lm/W, IF = 100 mA).

7.2. Aiming Pattern

The aiming is used for the following purpose:

1. Light source for bar code reading
2. Light source to indicate the appropriate reading range

The aiming specifications are as follows:

- An optical axis of imaging field of view and the center of horizontal aiming width coincide at a distance of $L=60\pm 10$ mm from the front edge of the scanner.
- The horizontal aiming width to the horizontal width of imaging field of view at a distance of $L=60$ mm is $100\%\pm 10\%$.

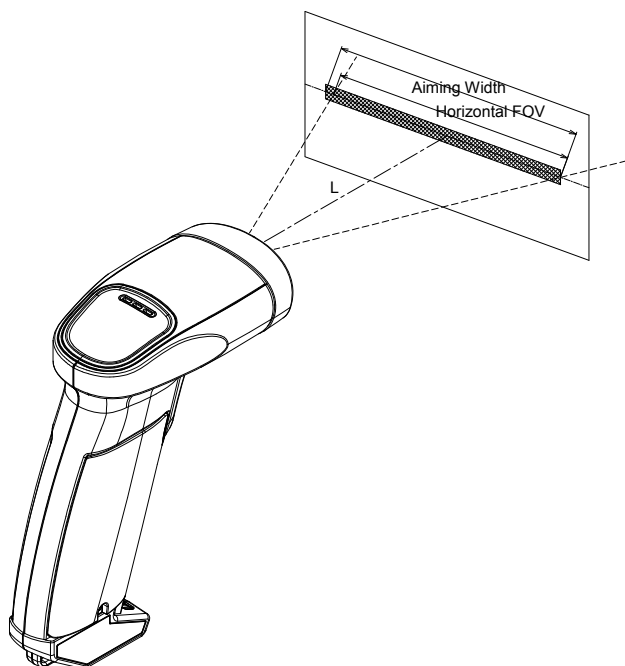

Figure 2: Aiming Pattern and Imaging Range

8. Technical Specifications

The conditions for technical specifications are as follows unless otherwise specified in each section.

<Conditions>

Temperature and humidity	: Room temperature, room humidity
Ambient light	: 200 ~ 300 lx
Angles	: Pitch: $\alpha = 0^\circ$, Skew: $\beta = 15^\circ$, Tilt: $\gamma = 0^\circ$
Curvature	: $R = \infty$
Power supply voltage	: 3.7 V
Reading test	: 1 read in 0.5 sec or less. Accept the performance with 10 consecutive successes
Bar code test sample	: OPTOELECTRONICS test samples. Refer to Section 8.1. for details.

8.1. Bar Code Test Sample

<Code 39>

Resolution	Symbology	PCS	Quiet Zone	No. of Digits
1.0 mm	Code 39	0.9	25 mm	1
0.5 mm			18 mm	3
0.25 mm			10 mm	8
0.2 mm			10 mm	34
0.15 mm			7 mm	10
0.127 mm			5 mm	4
0.1 mm			5 mm	4

<JAN>

Resolution	Symbology	PCS	Quiet Zone	No. of Digits
0.26 mm	JAN	0.9	10 mm	13
0.26 mm			10 mm	8
0.33 mm			10 mm	13

8.2. Scan Area and Depth of Field

The scan area is within the arc centered on the scan origin as shown in each resolution, which is measured from the front edge of the scanner.

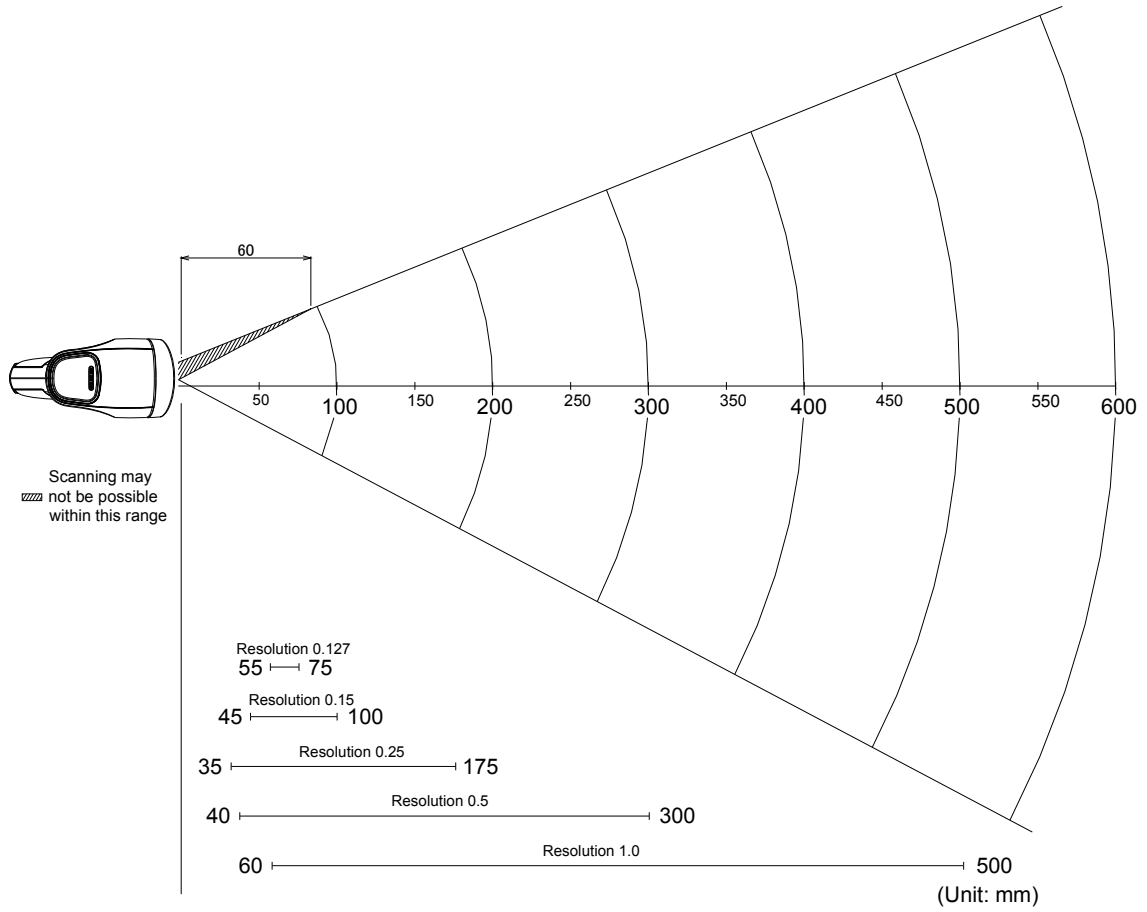

Figure 3: Scan Area and Depth of Field

8.3. Printed Contrast Signal (PCS)

0.3 or higher

<Conditions>

- MRD : 32% and higher
(70% or higher reflectivity of space and quiet zone)
- Distance : 72 mm from the front edge of the scanner
- Bar code** : JAN (resolution 0.26 mm, PCS 0.3) specified in Section 8.1.

MRD = Minimum reflectance of white space - Maximum reflectance of black bar

$$PCS = \frac{\text{Reflectance of white space} - \text{Reflectance of black bar}}{\text{Reflectance of white space}}$$

* Be sure to keep the optical window clean without dirt or scratches, or it may have a bad effect on the reading characteristics.

8.4. Minimum Resolution

0.1 mm or more

<Conditions>

- Bar code** : Code 39 (resolution 0.1 mm) specified in Section 8.1.
- Distance : 72 mm from the front edge of the scanner
- Angle : $\alpha = 0^\circ$, $\beta = +15^\circ$, $\gamma = 0^\circ$
- Curvature : $R = \infty$

8.5. Wide Bar Code

Code 39 with width of 110 mm and resolution of 0.2 mm can be read

<Conditions>

- Bar code** : Code 39 (resolution 0.20 mm, PCS 0.9) specified in Section 8.1.
- Distance : 127 mm from the front edge of the scanner
- Angle : $\alpha = 0^\circ$, $\beta = +15^\circ$, $\gamma = 0^\circ$
- Curvature : $R = \infty$

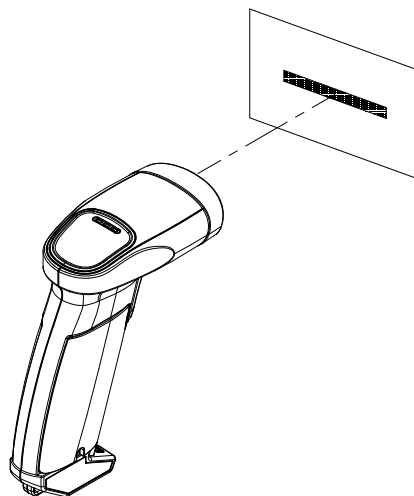

Figure 4: Wide Bar Code

8.6. Pitch, Skew and Tilt

Pitch : $\alpha = \pm 50^\circ$
 Skew : $\beta = \pm 65^\circ$
 Dead zone : $\beta = \pm 8^\circ$
 Tilt : $\gamma = \pm 25^\circ$

<Conditions>

Bar code : JAN (resolution 0.33 mm) specified in Chapter 8.1
 Distance : 72 mm from the front edge of the scanner
 Curvature : $R = \infty$
 Angle : Pitch $\beta = +15^\circ, \gamma = 0^\circ$
 Skew, Dead zone $\alpha = 0^\circ, \gamma = 0^\circ$
 Tilt $\alpha = 0^\circ, \beta = +15^\circ$

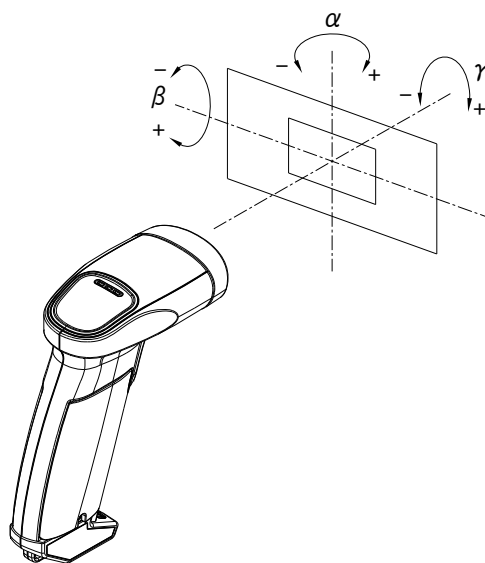

Figure 5: Pitch, Skew and Tilt

8.7. Curvature

0.26 mm 8-digit JAN : $R \geq 15$ mm
 0.26 mm 13-digit JAN : $R \geq 20$ mm

<Conditions>

Bar code : JAN (resolution 0.26 mm) specified in Section 8.1.
 Distance : 127 mm from the front edge of the scanner
 Angle : $\alpha = 0^\circ, \beta = +15^\circ, \gamma = 0^\circ$

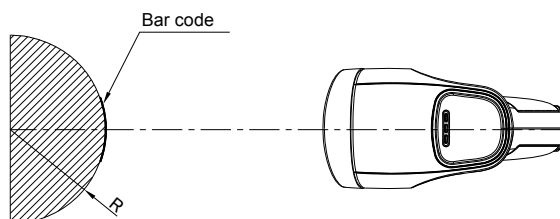

Figure 6: Curvature

* The reading characteristics may deteriorate due to the specular reflection of LED illumination when the reflectivity is high.

8.8. Scanning from LCD Screen

Bar codes displayed on LCD screens (brightness of white part 30 cd/m² or more, contrast ratio 100:1) can be read.

<Conditions>

- Bar code : JAN (resolution 0.26 mm) specified in Section 8.1.
- Ambient light : 100 lx or less
- Distance : 127 mm from the front edge of the scanner
- Angle : $\alpha = 0^\circ, \beta = 0^\circ, \gamma = 0^\circ$
- LCD screen type : Transmissive (backlight) TFT

$$\text{Contrast ratio} = \frac{\text{Brightness of white parts}}{\text{Brightness of black parts}}$$

- * The bar code resolution is the value when displayed on the LCD screen.
- * The width of bar code element is an integral multiple of pixel width of LCD screen.
- * The reading characteristics may deteriorate due to the specular reflection of LED illumination when the reflectivity is high.

8.9. Auto Trigger

When the scanner is placed in a dedicated stand (sold separately) which contains a magnet, it can detect this magnet and enters auto trigger mode. The scanner starts scanning automatically when it detects a change in brightness that occurs when a bar code label is presented in front of it.

8.9.1. Stand Detection

“Stand detection - Auto trigger flow”

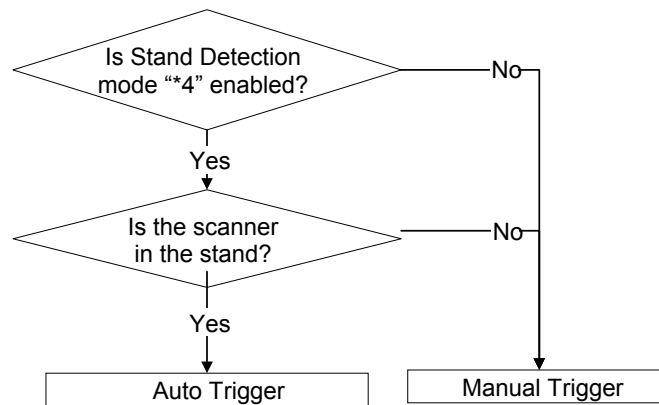

Figure 7: Stand Detection Flow

- * The dedicated stand is an optional accessory that can be purchased separately.
- * The stand detection mode is disabled by default. It must be enabled to be used.

8.9.2. Auto Trigger Operation

The scanner has an optional auto trigger mode in which it starts to read a bar code automatically when it detects one.

When auto trigger mode is enabled, the scanner tries to detect bars at regular intervals and when it detects 18 or more bars, it enters read mode in which it tries to decode a bar code.

When the scanner continues to detect bars after the reading has been done, it will assume those bars are from the same bar code as the previous one and will not attempt to read it.

When the detecting conditions are not met, the scanner will perform the intermittent scanning again until the next bar code is detected.

<Conditions>

Angle of paper : Skew angle, excluding pitch angle and dead zone, specified in Section 8.6

Temperature / Humidity : Room temperature / room humidity

Ambient light : 500 ~ 1000 lx

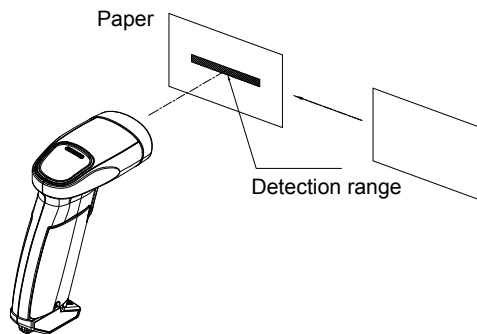

Figure 8: Auto Trigger

9. Environmental Specifications

9.1. Temperature

Scanning performance is guaranteed when the range of ambient temperature around the scanner is the following values:

Operating temperature	: 0 ~ 50 °C
Storage temperature	: -20 ~ 60°C

9.2. Humidity

Scanning performance is guaranteed when the range of ambient humidity around the scanner is the following values:

Operating humidity	: 20 ~ 85% RH (no condensation, no frost)
Storage humidity	: 20 ~ 85% RH (no condensation, no frost)

9.3. Ambient Light Immunity

Scanning performance is guaranteed when the range of illumination on a bar code surface is between zero and the following values:

Incandescent light	: 10,000 lx
Fluorescent light	: 10,000 lx
Sunlight	: 100,000 lx

<Conditions>

Bar code	: JAN (resolution 0.26 mm) specified in Section 8.1.
Distance	: 72 mm from the front edge of the camera module
Angle	: $\alpha = 0^\circ$, $\beta = +15^\circ$, $\gamma = 0^\circ$
Curvature	: $R = \infty$
Power supply voltage	: 3.7 V

* Be sure that the direct light or specular reflection from the light source does not enter the light receiving section of the scanner.

9.4. Dust and Drip Proof

IEC IP42 equivalent

Protection against solid objects: Level 4 equivalent

Protected against solid objects greater than 1.0 mm

Protection against liquids: Level 2 (JIS IPX2) equivalent

Protected against dripping water from the vertical when tilted up to 15°

* () is JIS drip-proof type.

9.5. Vibration Strength (without packing)

There shall be no sign of malfunction after the following vibration test.

Vibration test: Increase the frequency of the vibration from 10Hz to 100Hz at an accelerated velocity of 19.6m/s^2 (2.0 G) for 30 minutes (60 minutes per cycle) in the non-operating state. Repeat this in each X, Y and Z direction.

9.6. Vibration Strength (in individual packing)

There shall be no sign of malfunction after the following vibration test.

Vibration test: Increase the frequency of the vibration from 10Hz to 100Hz at an accelerated velocity of 19.6 m/s^2 (2.0 G) for 30 minutes (60 minutes per cycle) in individually packaged state. Repeat this in each X, Y and Z direction.

9.7. Drop Impact Strength (without packaging)

There shall be no sign of malfunction after the following drop test.

Drop test: Drop the scanner 30 times in total (5 times at each 6 face) from a height of 150 cm onto a concrete floor as shown below.

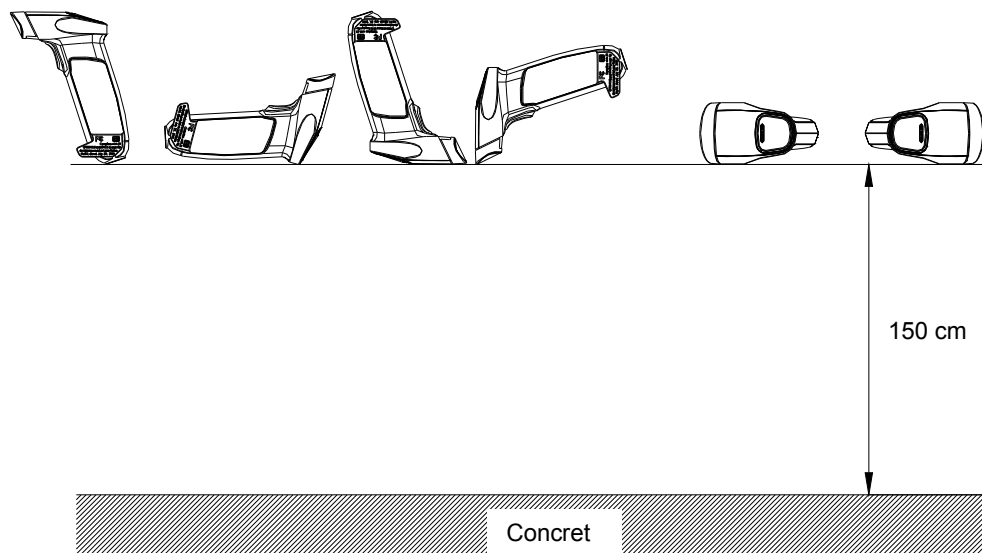

Figure 9: Drop Test

9.8. Drop Impact Strength (in individual packaging)

There shall be no sign of malfunction after the following drop test.

Drop test: Drop an individually packaged scanner 10 times in total, at any of 1 corner, 3 edges, and 6 faces, from a height of 150 cm onto a concrete floor.

9.9. Electrostatic Discharge (ESD) Immunity

Contact discharge	: $\pm 6 \text{ kV}$ max (direct or indirect discharge, no malfunction)
Aerial discharge	: $\pm 8 \text{ kV}$ max (no malfunction)
	$\pm 15 \text{ kV}$ max (no distraction)
Measurement environment	: Testing method compliant with IEC-61000-4-2.
Discharge resistance	: 330Ω
Charging capacitor	: 150 pF

10. Regulatory Compliance

10.1. LED Safety

IEC 62471:2006 Exempt_Group

10.2. Product Safety

EN60950-1:2006
IEC60950-1:2005

10.3. EMC

R&TTE Directive

- EN 55022:2010
- EN 301 489-1 V1.9.2
- EN 301 489-17 V2.1.1
- EN 300 328 V1.8.1

FCC Part 15 Subpart C Class B

Federal Communications Commission Notices

This product complies with Part 15 of the FCC Rules. Operation is subject to the following two conditions:

- (1) this device may not cause harmful interference, and
- (2) this device must accept any interference received, including interference that may cause undesired operation.

Harmful Interference Notice

This product has been tested and complies with the specifications for a Class B digital device, pursuant to Part 15 of the FCC Rules. These limits are designed to provide reasonable protection against harmful interference in a residential installation. This equipment generates, uses, and can radiate radio frequency energy and, if not installed and used according to the instructions, may cause harmful interference to radio communications. However, there is no guarantee that interference will not occur in a particular installation. If this equipment does cause harmful interference to radio or television reception, which is found by turning the equipment off and on, the user is encouraged to try to correct the interference by one or more of the following measures:

- Reorient or relocate the receiving antenna
- Increase the separation between the equipment or devices
- Connect the equipment to an outlet other than the receiver's
- Consult a dealer or an experienced radio/TV technician for assistance

Changes or modifications to this equipment that have not been approved by Ruckus Wireless may void the user's authority to operate this equipment.

RF Exposure Information

This product complies with FCC radiation exposure limits set forth an uncontrolled environment.

VCCI Class B

This is a Class B product, to be used in a domestic environment, based on the Technical Requirement of the Voluntary Control Council for Interference from Information Technology Equipment (VCCI). If this is used near a radio or television receiver in a domestic environment, it may cause radio interference.

10.4. Others

- Bluetooth logo certification
- MFi license

“Made for iPod,” “Made for iPhone,” and “Made for iPad” mean that an electronic accessory has been designed to connect specifically to iPod, iPhone, or iPad, respectively, and has been certified by the developer to meet Apple performance standards. Apple is not responsible for the operation of this device or its compliance with safety and regulatory standards. Please note that the use of this accessory with iPod, iPhone, or iPad may affect wireless performance.



- Certification for Construction Design of Specified Radio Equipment

• Classification of Specified Radio Equipment	Article 2 Paragraph 1, Item 19 Low power data communication system in 2.4 GHz band
• Model Name	OPA-26X1
• Certificate Number	201-125603

11. RoHS

The OPC-3301i is compliant with RoHS.

RoHS: The restriction of the use of certain hazardous substances in electrical and electronic equipment, 2011/65/EU

12. Reliability

MTBF (Mean Time Between Failures) 10,000 hours

13. Precautions

13.1. Handling

Handle this product carefully. Do not deliberately subject it to any of the following.

(1) Shock:

- Do not drop this product from a height greater than specified in this manual.
- Do not place this product under or between any heavy items.
- Do not swing the cable around.

(2) Temperature Conditions:

- Do not use this product at temperatures outside the specified range.
- Do not pour boiling water on this product.
- Do not throw this product into a fire.

(3) Foreign Materials:

- Do not immerse this product in water or other liquid.
- Do not expose this product to chemicals.

(4) Others

- Do not disassemble this product.
- Do not use this product near a radio or a TV. It may cause reception problems.
- This product may be affected by a momentary voltage drop caused by lightning.
- iPhone, iPad and iPod are trademarks of Apple Inc.
- Other company and product names may be trademarks of their respective owners.

13.2. Radio Law

This product qualifies as specified radio equipment for radio stations of 2.4 GHz band data communication system and has obtained the Certification for Construction Design of Specified Radio Equipment. Therefore, radio station license is not required in Japan. The following activities are prohibited under the Radio Law:

- Remodeling and disassembly
- Peeling off the certificate label

Do not use this equipment under the following environment, as radio interference may affect other device and end up with causing physical or material damage.

- Safety apparatus and medical device for human body protection
- Environment where is concerned to cause serious damage

13.3. Bluetooth

- This product supports Bluetooth wireless communication with other Bluetooth devices that have the same profile
- This product complies with Bluetooth standards; however, its communication performance with untested devices is not guaranteed.
- Bluetooth devices use the 2.4 GHz frequency band that is shared among other devices. It may affect the communication speed and distance between this product and the host device.
- The communication speed and distance vary depending on the interference and radio wave condition between this product and the host device.

13.4. Frequency Band

This product uses the 2.4 GHz frequency band. Read carefully the followings before using this product.

In the frequency band of this product, scientific, medical and industrial devices including microwaves are used. Also other radio stations including local private radio station for mobile object identification requiring license for such as manufacturing lines at factories, specific power-saving radio station requiring no license and amateur radio station are managed.

1. Make sure that "other radio stations" are not managed in the frequency band 2.4 GHz before using this product.
2. In case that radio interference occurs between this product and "other radio stations," change the service space immediately, or stop transmitting radio wave to avoid the interference.
3. If you have any questions or troubles, please contact our sales office.

14. Product Labels

The product labels are affixed to the scanner as shown below.

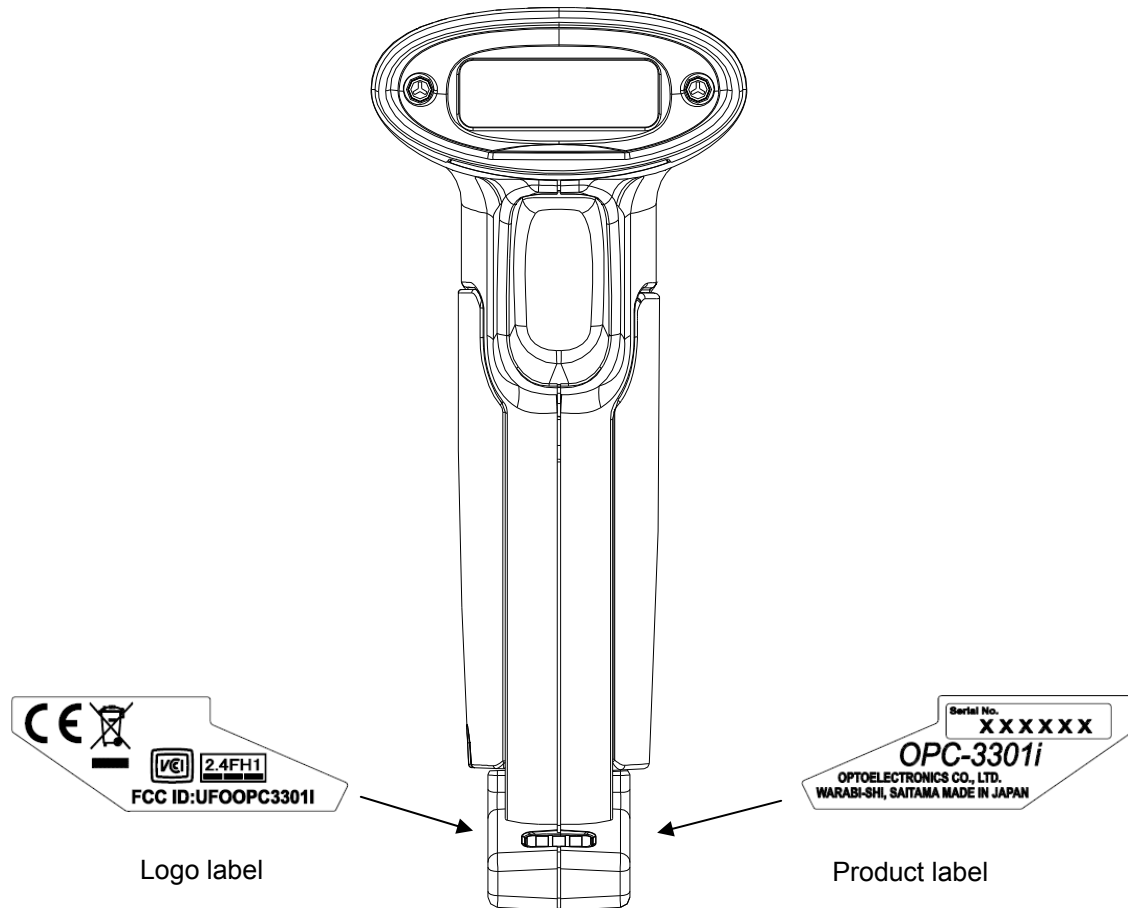

Figure 10: Product Labels

Product label	Shows the product name, serial number, and month and year of manufacture.
Logo label	Shows the standards-compliant languages and logos.

15. Packaging Specifications

15.1. Individual Packaging

Assembled package size: 165 × 110 × 82 (WDH mm)

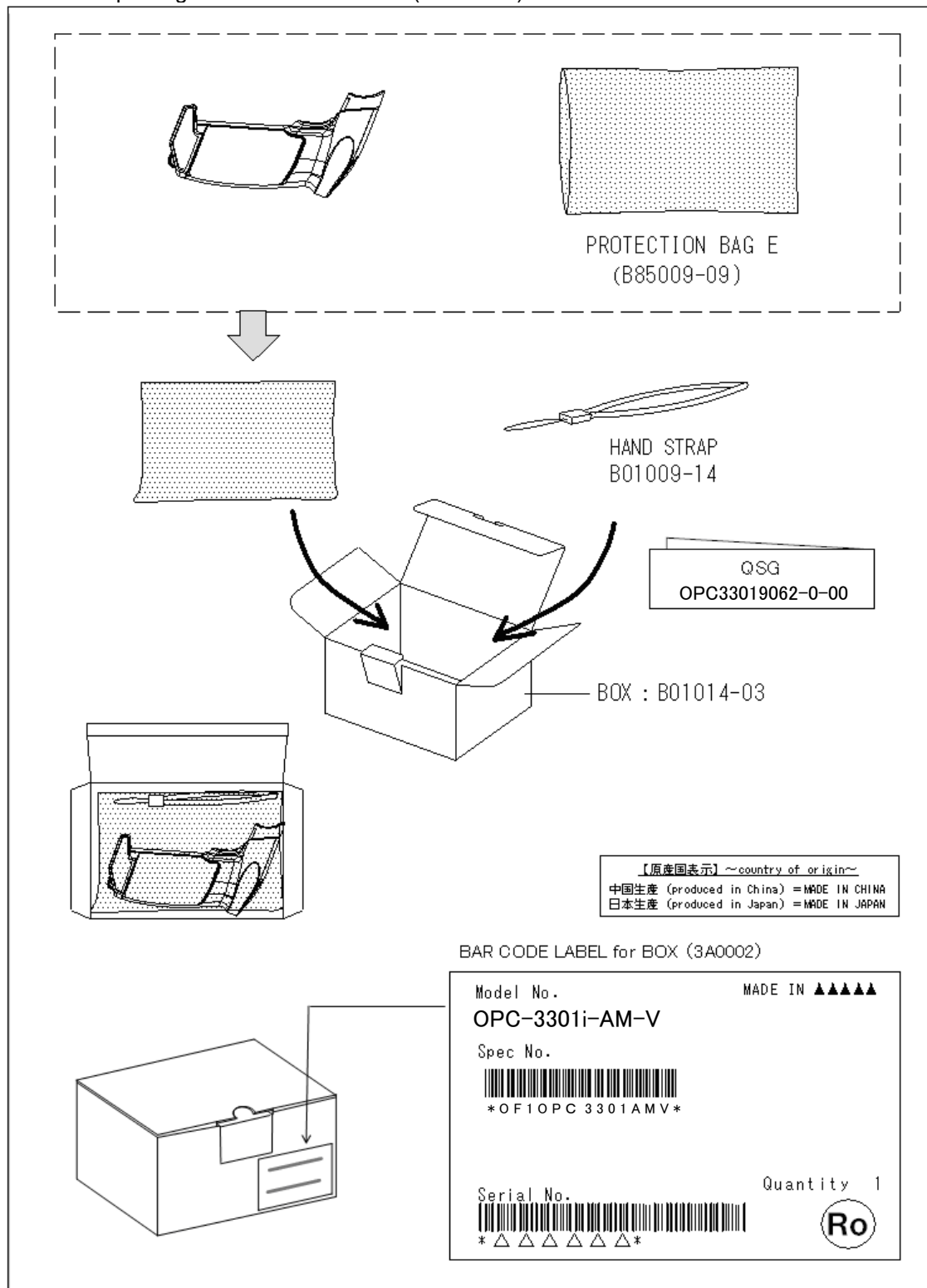

Figure 11: Individual Packaging

15.2. Collective Packaging

Assembled package size : 585 × 520 × 200 (WDH mm)

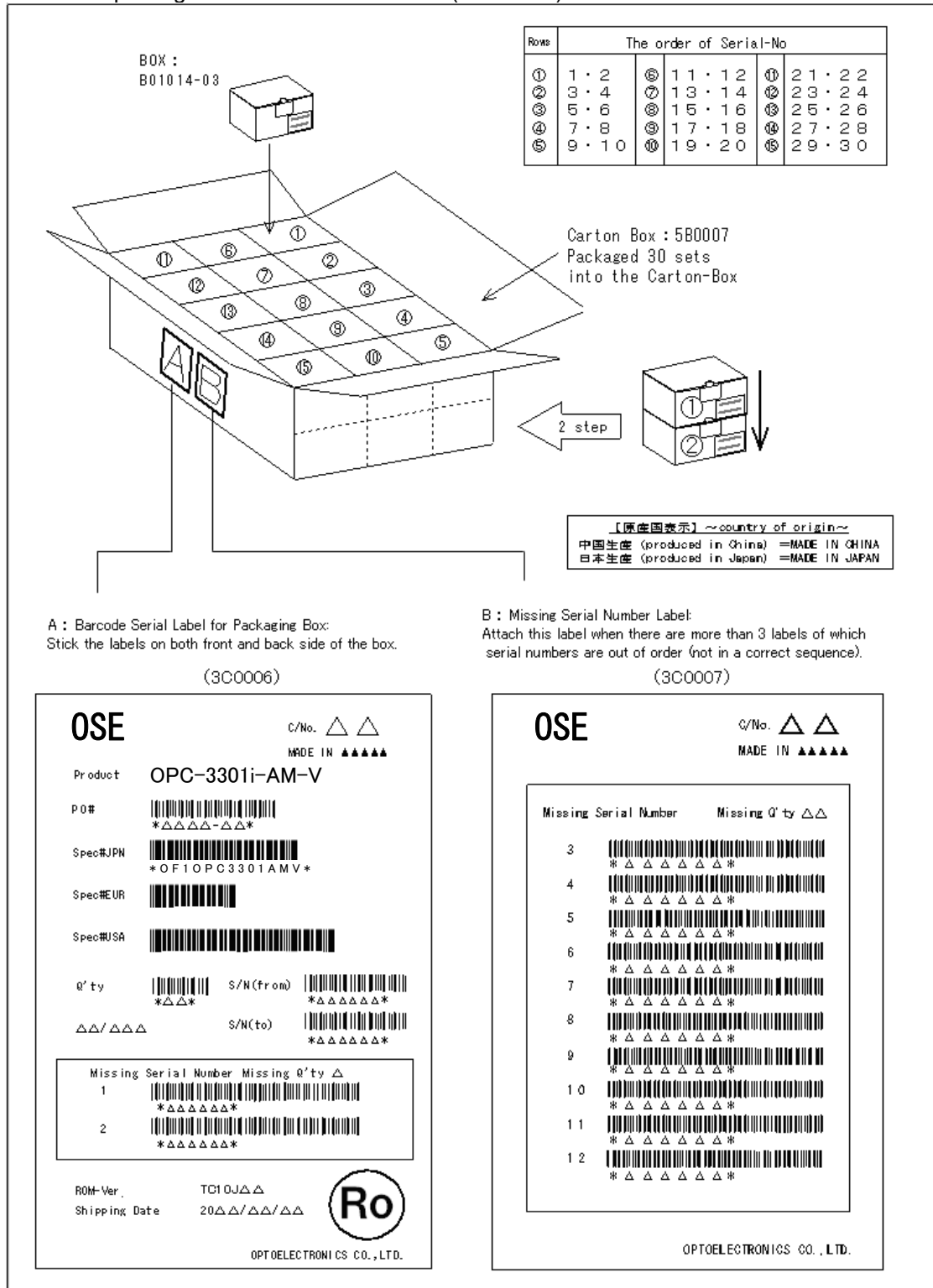

Figure 12: Collective Packaging

* 'Ro mark' on the boxes for the product indicates that the product is RoHS compliant declared by Optoelectronics Co., Ltd.

16. Physical Features

16.1. Dimensions

56 × 113 × 132 (WDH mm / excluding protruding portion)

16.2. Weight

Approx. 127 g (excluding accessories)

16.3. Mechanical Drawing

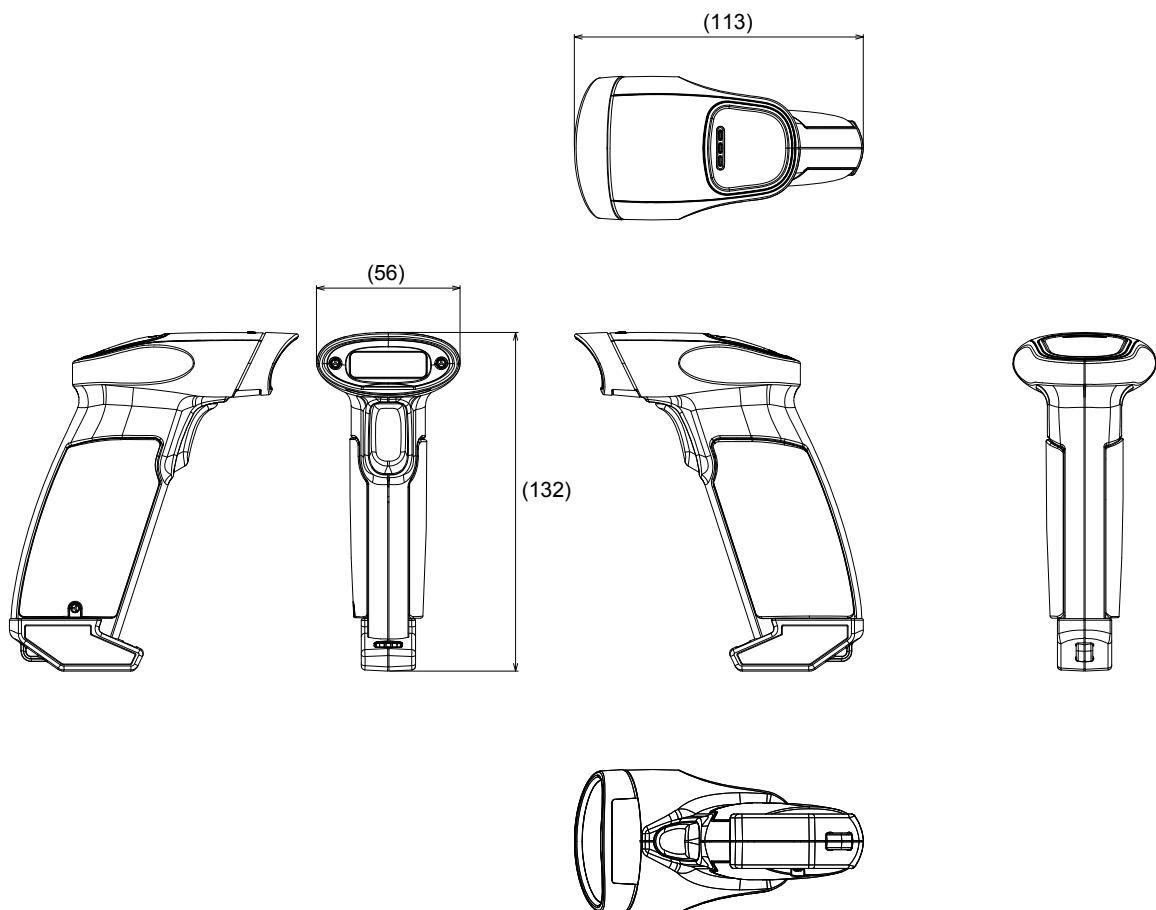





Figure 13: Mechanical Drawing

17. Supported Symbologies

17.1. Default Setting

The scanner is set to default settings by reading the following menu labels.

Function	Menu label	Menu code
SET		ZZ
Default		SO
END		ZZ

17.2. Supported Symbologies

17.2.1. 1D Bar Codes

Code type	Default	Minimum length	Note
UPC	○	-	
UPC Add-on 2			
UPC Add-on 5			
EAN (JAN)	○	-	
EAN Add-on 2			
EAN Add-on 5			
EAN-13	○		
EAN-13 Add-on 2			
EAN-13 Add-on 5			
EAN-8	○		
EAN-8 Add-on 2			
EAN-8 Add-on 5			
Code 39	○	1	Not transmit ST/SP
Tri-Optic	○	-	Not transmit ST/SP
Codabar (NW7)	○	5	Not transmit ST/SP
Industrial 2 of 5	○	5	
Interleaved 2 of 5	○	6	
S-Code	○	5	
Code 128	○	1	GS1 conversion (setting required)
Code 93	○	1	
IATA	○	5	
MSI/Plessey	○	3	
UK/Plessey	○	2	
TELEPEN	○	1	
Code 11		1	
Matrix 2 of 5		5	
Chinese Post Matrix 2 of 5		-	
Korean Postal Authority		-	

17.2.2. GS1 Databar, Composite Code

Code type	Default	Note
GS1 DataBar ·GS1 DataBar Omnidirectional ·GS1 DataBar Truncated ·GS1 DataBar Stacked ·GS1 DataBar Stacked Omnidirectional	○	GS1 conversion (setting required)
GS1 DataBar Limited	○	
GS1 DataBar Expanded ·GS1 DataBar Expanded ·GS1 DataBar Expanded Stacked	○	

* The supported symbologies vary depending on specifications for the application to be loaded.