

FCC PART 15.247  
MEASUREMENT AND TEST REPORT

For

**Gajah International (HK) Co., Ltd**

18/F Bel Trade Commercial Building, 1-3, Burrows Street, Wan Chai, Hong Kong

**FCC ID: UFKTB200200**

<b>Report Type:</b> Original Report	<b>Product Type:</b> TV-BOX
<b>Test Engineer:</b> Mick Yin	<i>Mick Yin</i>
<b>Report Number:</b> RSZ120920003-00B	
<b>Report Date:</b> 2012-10-17	
<b>Reviewed By:</b> Sula Huang RF Engineer	<i>Sula Huang</i>
<b>Test Laboratory:</b>	Bay Area Compliance Laboratories Corp. (Shenzhen) 6/F, the 3rd Phase of WanLi Industrial Building ShiHua Road, FuTian Free Trade Zone Shenzhen, Guangdong, China Tel: +86-755-33320018 Fax: +86-755-33320008 <a href="http://www.baclcorp.com.cn">www.baclcorp.com.cn</a>

Note: This test report is prepared for the customer shown above and for the equipment described herein. It may not be duplicated or used in part without prior written consent from Bay Area Compliance Laboratories Corp. This report must not be used by the customer to claim product certification, approval, or endorsement by NVLAP\*, or any agency of the Federal Government.

\* This report may contain data that are not covered by the NVLAP accreditation and shall be marked with an asterisk "★"

## TABLE OF CONTENTS

<b>GENERAL INFORMATION.....</b>	<b>4</b>
PRODUCT DESCRIPTION FOR EQUIPMENT UNDER TEST (EUT).....	4
OBJECTIVE .....	4
RELATED SUBMITTAL(S)/GRANT(S).....	4
TEST METHODOLOGY .....	4
TEST FACILITY .....	5
<b>SYSTEM TEST CONFIGURATION.....</b>	<b>6</b>
DESCRIPTION OF TEST CONFIGURATION .....	6
EUT EXERCISE SOFTWARE .....	6
EQUIPMENT MODIFICATIONS .....	6
REMOTE OR SUPPORT EQUIPMENT LIST AND DETAILS.....	6
EXTERNAL I/O CABLE.....	7
BLOCK DIAGRAM OF TEST SETUP .....	7
<b>SUMMARY OF TEST RESULTS .....</b>	<b>9</b>
<b>§15.247 (i) &amp; §1.1307 (b) (1), §2.1091 – MAXIMUM PERMISSIBLE EXPOSURE (MPE) .....</b>	<b>10</b>
APPLICABLE STANDARD .....	10
<b>FCC §15.203 - ANTENNA REQUIREMENT.....</b>	<b>11</b>
APPLICABLE STANDARD .....	11
ANTENNA CONNECTOR CONSTRUCTION .....	11
<b>FCC §15.207 (a) - CONDUCTED EMISSIONS .....</b>	<b>12</b>
APPLICABLE STANDARD .....	12
MEASUREMENT UNCERTAINTY .....	12
EUT SETUP.....	12
EMI TEST RECEIVER SETUP.....	13
TEST EQUIPMENT LIST AND DETAILS.....	13
TEST PROCEDURE .....	13
TEST RESULTS SUMMARY.....	13
TEST DATA .....	14
<b>FCC §15.209, §15.205 &amp; §15.247(d) - SPURIOUS EMISSIONS.....</b>	<b>17</b>
APPLICABLE STANDARD .....	17
MEASUREMENT UNCERTAINTY .....	17
EUT SETUP.....	17
EMI TEST RECEIVER & SPECTRUM ANALYZER SETUP .....	18
TEST EQUIPMENT LIST AND DETAILS.....	18
TEST PROCEDURE .....	18
CORRECTED AMPLITUDE & MARGIN CALCULATION .....	19
TEST RESULTS SUMMARY.....	19
TEST DATA .....	19
<b>FCC §15.247(a) (2) – 6 dB BANDWIDTH TESTING .....</b>	<b>31</b>
APPLICABLE STANDARD .....	31
TEST EQUIPMENT LIST AND DETAILS.....	31
TEST PROCEDURE .....	31
TEST DATA .....	31
<b>FCC §15.247(b) (3) - MAXIMUM PEAK OUTPUT POWER .....</b>	<b>38</b>

APPLICABLE STANDARD .....38  
TEST EQUIPMENT LIST AND DETAILS.....38  
TEST PROCEDURE .....38  
TEST DATA .....38

**FCC §15.247(d) – 100 kHz BANDWIDTH OF FREQUENCY BAND EDGE.....44**

APPLICABLE STANDARD .....44  
TEST EQUIPMENT LIST AND DETAILS.....44  
TEST PROCEDURE .....44  
TEST DATA .....44

**FCC §15.247(e) - POWER SPECTRAL DENSITY .....49**

APPLICABLE STANDARD .....49  
TEST EQUIPMENT LIST AND DETAILS.....49  
TEST PROCEDURE .....49  
TEST DATA .....49

---

## GENERAL INFORMATION

---

### Product Description for Equipment under Test (EUT)

The *Gajah International (HK) Co., Ltd*'s product, model number: *TB2002 (FCC ID: UFKTB200200)* or the "EUT" as referred to in this report was a *TV-BOX*, which was measured approximately: 179.7 cm (L) x 119.6 cm (W) x 29.6 cm (H), rated input voltage: DC 5V from adapter.

Adapter Information: AC ADAPTER  
Model: HND050200U;  
Input: 100-240V~ 50/60Hz 0.35A MAX;  
Output: DC 5.0V 2.0A

*\* All measurement and test data in this report was gathered from production sample serial number: 1209106 (Assigned by BACL, Shenzhen). The EUT supplied by applicant was received on 2012-09-20.*

### Objective

This report is prepared on behalf of *Gajah International (HK) Co., Ltd* in accordance with Part 2, Subpart J, Part 15, Subparts A, B and C of the Federal Communication Commissions rules.

The tests were performed in order to determine compliance with FCC Part 15, Subpart C, and section 15.203, 15.205, 15.207, 15.209 and 15.247 rules.

### Related Submittal(s)/Grant(s)

FCC Part 15B JBP submission with FCC ID: UFKTB200200.

### Test Methodology

All measurements contained in this report were conducted with ANSI C63.4-2009, American National Standard for Methods of Measurement of Radio-Noise Emissions from Low-Voltage Electrical and Electronic Equipment in the range of 9 kHz to 40 GHz.

All emissions measurement was performed and Bay Area Compliance Laboratories Corp. (Shenzhen). The radiated testing was performed at an antenna-to-EUT distance of 3 meters.

## Test Facility

The Test site used by Bay Area Compliance Laboratories Corp. (Shenzhen) to collect test data is located in the 6/F, the 3rd Phase of WanLi Industrial Building, Shihua Road, Futian Free Trade Zone Shenzhen, Guangdong, China.

Test site at Bay Area Compliance Laboratories Corp. (Shenzhen) has been fully described in reports submitted to the Federal Communication Commission (FCC). The details of these reports have been found to be in compliance with the requirements of Section 2.948 of the FCC Rules on December 06, 2010. The facility also complies with the radiated and AC line conducted test site criteria set forth in ANSI C63.4-2009.

The Federal Communications Commission has the reports on file and is listed under FCC Registration No.: 382179. The test site has been approved by the FCC for public use and is listed in the FCC Public Access Link (PAL) database.

Additionally, Bay Area Compliance Laboratories Corp. (Shenzhen) is a National Institute of Standards and Technology (NIST) accredited laboratory, under the National Voluntary Laboratory Accredited Program (Lab Code 200707-0).



The current scope of accreditations can be found at <http://ts.nist.gov/Standards/scopes/2007070.htm>

## SYSTEM TEST CONFIGURATION

### Description of Test Configuration

For 802.11b, 802.11g mode and 802.11n-HT20, 11 channels are provided to testing:

Channel	Frequency (MHz)	Channel	Frequency (MHz)
1	2412	7	2442
2	2417	8	2447
3	2422	9	2452
4	2427	10	2457
5	2432	11	2462
6	2437	/	/

EUT for 802.11b, 802.11g and 802.11n-HT20 modes were tested with Channel 1, 6 and 11.

The worst-case data rates are determined to be as follows for each mode based upon investigations by measuring the average power and PSD across all data rates bandwidths, and modulations.

### EUT Exercise Software

Test software: RT3352QA (provided by the Applicant)

The test was performed under:

802.11b: Data rate: 1 Mbps.

802.11g: Data rate: 6 Mbps.

802.11N20: Data rate: 6.5 Mbps

### Equipment Modifications

No modification was made to the EUT tested.

### Remote or Support Equipment List and Details

Manufacturer	Description	Model	Serial Number
IBM	Laptop	2371	N/A
SAMSUNG	LCD TV MONITOR	225MS	CR22HVIP401073M
Kingston	USB Storage	2GB	N/A
SAGEMCOM	Modem/Router	F@st 3804	LK11153DP530005
Kingston	SD Card	2GB	--
DELL	Mouse	MOC5UO	G1900NKD

**External I/O Cable**

Cable Description	Length (m)	From/Port	To
Unshielded Detachable RJ45 Cables	10.0	EUT	Laptop
Shielded Detachable HDMI Cable with core	2.0	EUT	LCD TV MONITOR
Unshielded Detachable RJ45 Cables	10.0	EUT	Router
Unshielded DC Power Cable	1.5	EUT	Adapter
Shielded Detachable USB Cable	1.5	EUT	Mouse
Unshielded Detachable AV Cables	1.5	EUT	LCD TV MONITOR

**Block Diagram of Test Setup**

AC power-line conducted emission:

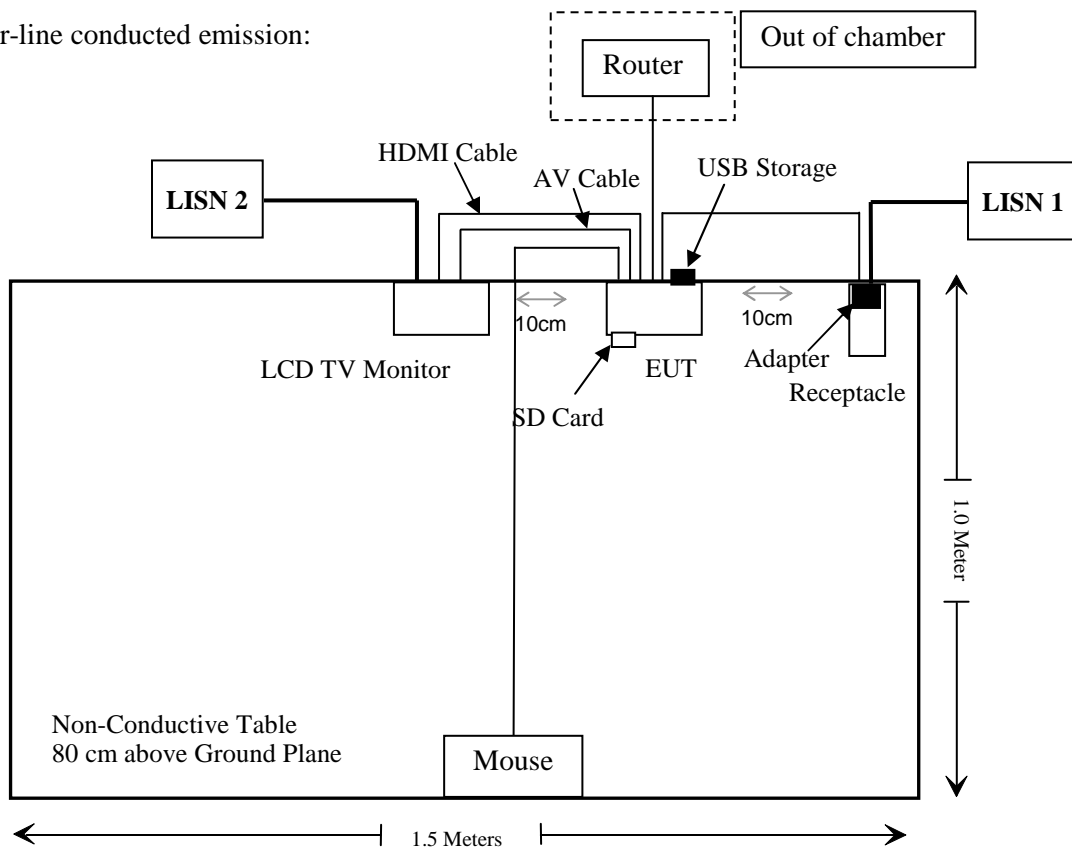

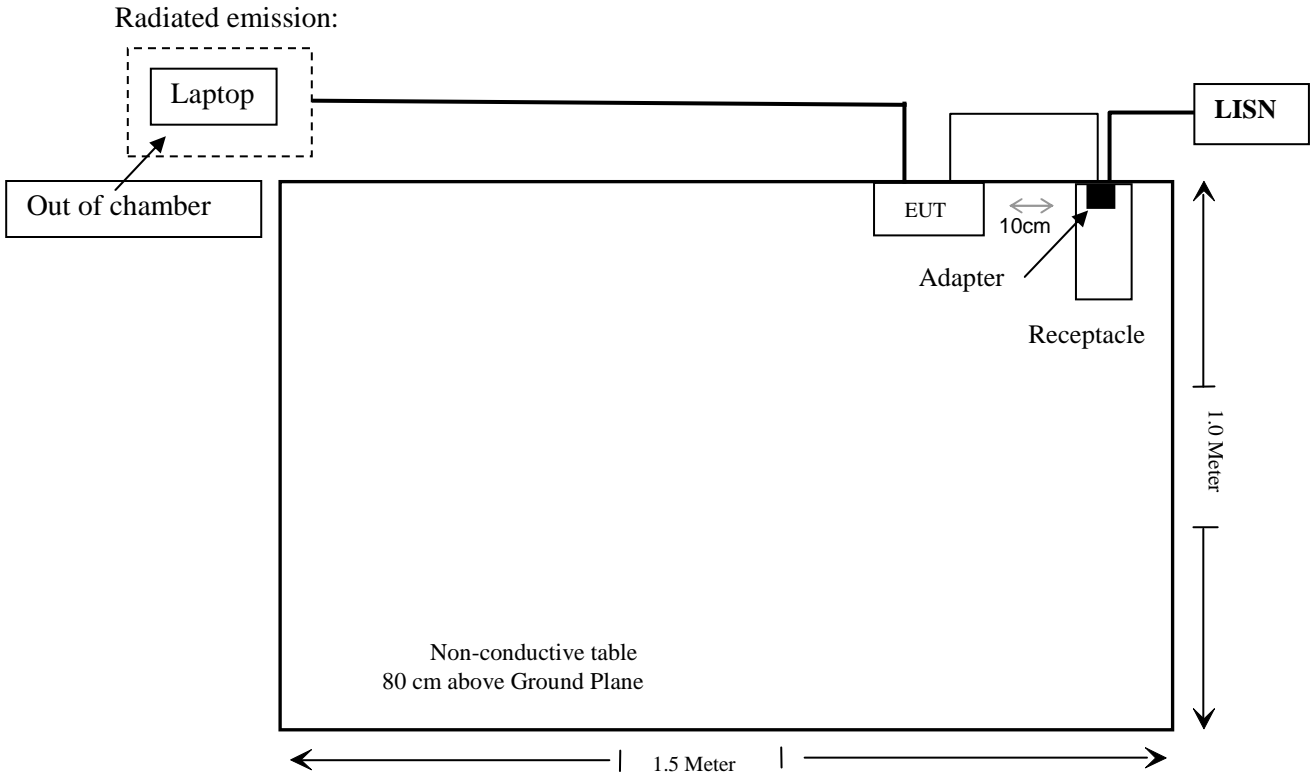



**SUMMARY OF TEST RESULTS**

<b>FCC Rules</b>	<b>Description of Test</b>	<b>Result</b>
§15.247 (i), §1.1307 (b) (1), §2.1091	Maximum Permissible Exposure (MPE)	Compliance
§15.203	Antenna Requirement	Compliance
§15.207 (a),	Conducted Emissions	Compliance
§15.247(d)	Spurious Emissions at Antenna Port	Compliance
§15.205, §15.209, §15.247(d)	Spurious Emissions	Compliance
§15.247 (a)(2)	6 dB Bandwidth	Compliance
§15.247(b)(3)	Maximum Peak Output Power	Compliance
§15.247(d)	100kHz Bandwidth of Frequency Band Edge	Compliance
§15.247(e)	Power Spectral Density	Compliance

**§15.247 (i) & §1.1307 (b) (1), §2.1091 – MAXIMUM PERMISSIBLE EXPOSURE (MPE)**

**Applicable Standard**

According to subpart 15.247(i) and subpart §1.1307(b)(1), systems operating under the provisions of this section shall be operated in a manner that ensures that the public is not exposed to radio frequency energy level in excess of the Commission’s guidelines.

Limits for Maximum Permissible Exposure (MPE) (§1.1310, §2.1091)

<b>(B) Limits for General Population/Uncontrolled Exposure</b>				
Frequency Range (MHz)	Electric Field Strength (V/m)	Magnetic Field Strength (A/m)	Power Density (mW/cm <sup>2</sup> )	Averaging Time (minutes)
0.3–1.34	614	1.63	*(100)	30
1.34–30	824/f	2.19/f	*(180/f <sup>2</sup> )	30
30–300	27.5	0.073	0.2	30
300–1500	/	/	f/1500	30
1500–100,000	/	/	1.0	30

f = frequency in MHz; \* = Plane-wave equivalent power density;

According to §1.1310 and §2.1091 RF exposure is calculated.

**Calculated Formulary:**

Predication of MPE limit at a given distance

$$S = PG/4\pi R^2$$

S = power density (in appropriate units, e.g. mW/cm<sup>2</sup>);

P = power input to the antenna (in appropriate units, e.g., mW);

G = power gain of the antenna in the direction of interest relative to an isotropic radiator, the power gain factor, is normally numeric gain;

R = distance to the center of radiation of the antenna (appropriate units, e.g., cm);

Mode	Frequency (MHz)	Antenna Gain		Conducted Power		Evaluation Distance (cm)	Power Density (mW/cm <sup>2</sup> )	MPE Limit (mW/cm <sup>2</sup> )
		(dBi)	(numeric)	(dBm)	(mW)			
802.11b	2462	2	1.58	12.22	16.672	20	0.00524	1
802.11g	2462	2	1.58	12.00	15.849	20	0.00498	1
802.11n-HT20	2462	2	1.58	11.44	13.932	20	0.00438	1

**Result: Compliance**

---

## **FCC §15.203 - ANTENNA REQUIREMENT**

---

### **Applicable Standard**

According to § 15.203, an intentional radiator shall be designed to ensure that no antenna other than that furnished by the responsible party shall be used with the device. The use of a permanently attached antenna or of an antenna that uses a unique coupling to the intentional radiator shall be considered sufficient to comply with the provisions of this section. The manufacturer may design the unit so that a broken antenna can be replaced by the user, but the user of a standard antenna jack or electrical connector is prohibited. The structure and application of the EUT were analyzed to determine compliance with section §15.203 of the rules. §15.203 state that the subject device must meet the following criteria:

- a. Antenna must be permanently attached to the unit.
- b. Antenna must use a unique type of connector to attach to the EUT.

Unit must be professionally installed, and installer shall be responsible for verifying that the correct antenna is employed with the unit.

And according to FCC 47 CFR section 15.247 (b), if the transmitting antennas of directional gain greater than 6dBi are used, the power shall be reduced by the amount in dB that the directional gain of the antenna exceeds 6 dBi.

### **Antenna Connector Construction**

The EUT has an integrated antenna arrangement, which was permanently attached and the gain was 2 dBi, fulfill the requirement of this section. Please refer to EUT photos.

**Result:** Compliance.

## FCC §15.207 (a) - CONDUCTED EMISSIONS

### Applicable Standard

FCC§15.207

### Measurement Uncertainty

All measurements involve certain levels of uncertainties, especially in field of EMC. The factors contributing to uncertainties are spectrum analyzer, cable loss, and LISN.

Based on CISPR 16-4-4, The Treatment of Uncertainty in EMC Measurements, the best estimate of the uncertainty of any conducted emissions measurement at Bay Area Compliance Laboratory Corp. (Shenzhen) is 2.4 dB (k=2, 95% level of confidence), and the uncertainty will not be taken into consideration for all the test data recorded in the report.

### EUT Setup

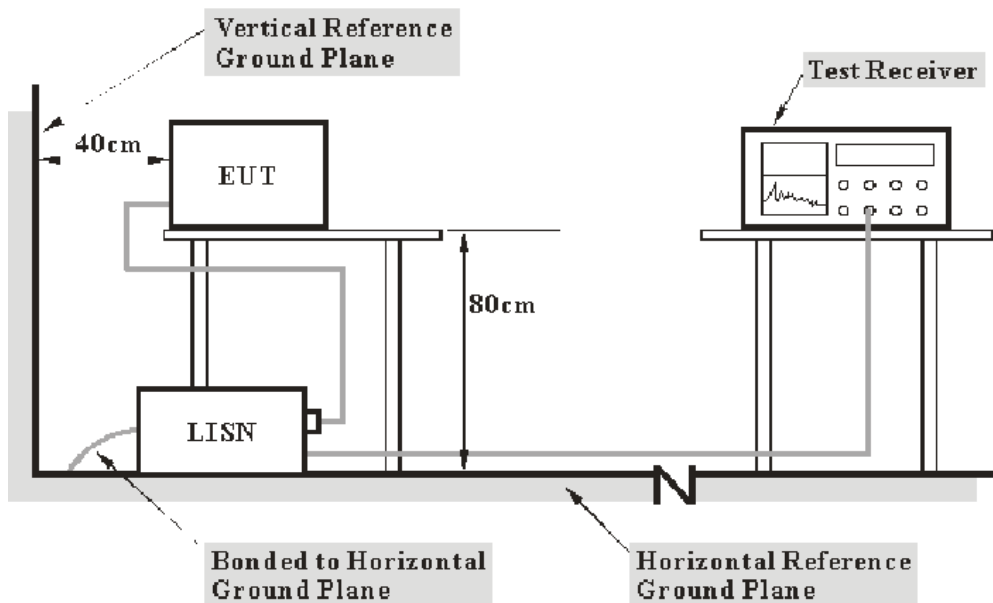

- Note: 1. Support units were connected to second LISN.  
2. Both of LISNs (AMN) 80 cm from EUT and at the least 80 cm from other units and other metal planes support units.

The measurement procedure of EUT setup is according with ANSI C63.4-2009. The related limit was specified in FCC Part 15.207.

The spacing between the peripherals was 10 cm.

The adapter was connected to a 120 VAC/60 Hz power source.

## EMI Test Receiver Setup

The EMI test receiver was set to investigate the spectrum from 150 kHz to 30 MHz.

During the conducted emission test, the EMI test receiver was set with the following configurations:

<b><i>Frequency Range</i></b>	<b><i>IF B/W</i></b>
150 kHz – 30 MHz	9 kHz

## Test Equipment List and Details

Manufacturer	Description	Model	Serial Number	Calibration Date	Calibration Due Date
Rohde & Schwarz	EMI Test Receiver	ESCS30	100176	2011-11-24	2012-11-23
Rohde & Schwarz	L.I.S.N.	ESH2-Z5	892107/021	2011-11-17	2012-11-16
Com-Power	L.I.S.N.	LI-200	12005	N/A	N/A
Rohde & Schwarz	Pulse limiter	ESH3Z2	DE25985	2012-07-08	2013-07-07
BACL	CE Test software	BACL-CE	V1.0	-	-

\* **Statement of Traceability:** Bay Area Compliance Laboratory Corp. (Shenzhen) attests that all calibrations have been performed in accordance to NVLAP requirements, traceable to the NIST.

## Test Procedure

During the conducted emission test, the adapter was connected to the LISN.

Maximizing procedure was performed on the six (6) highest emissions of the EUT.

All data was recorded in the Quasi-peak and average detection mode.

## Test Results Summary

According to the recorded data in following table, the EUT complied with the FCC Part 15.207, with the worst margin reading of:

**15.63 dB at 0.165 MHz** in the **Line** conducted mode

**Test Data****Environmental Conditions**

<b>Temperature:</b>	25 ° C
<b>Relative Humidity:</b>	50 %
<b>ATM Pressure:</b>	100.0 kPa

*The testing was performed by Mick Yin on 2012-09-26.*

The EUT was tested together with the above additional components and configuration, such case produced the worst emission level that was selected to test and recorded in this report.

Test Mode 1: 802.11b

Test Mode 2: 802.11g

Test Mode 3: 802.11n-HT20

After the preliminary scan, the following test mode was found to produce the highest emission level.

Test Mode: 802.11b-Transmitting (worse case)

AC 120V / 60Hz - Line

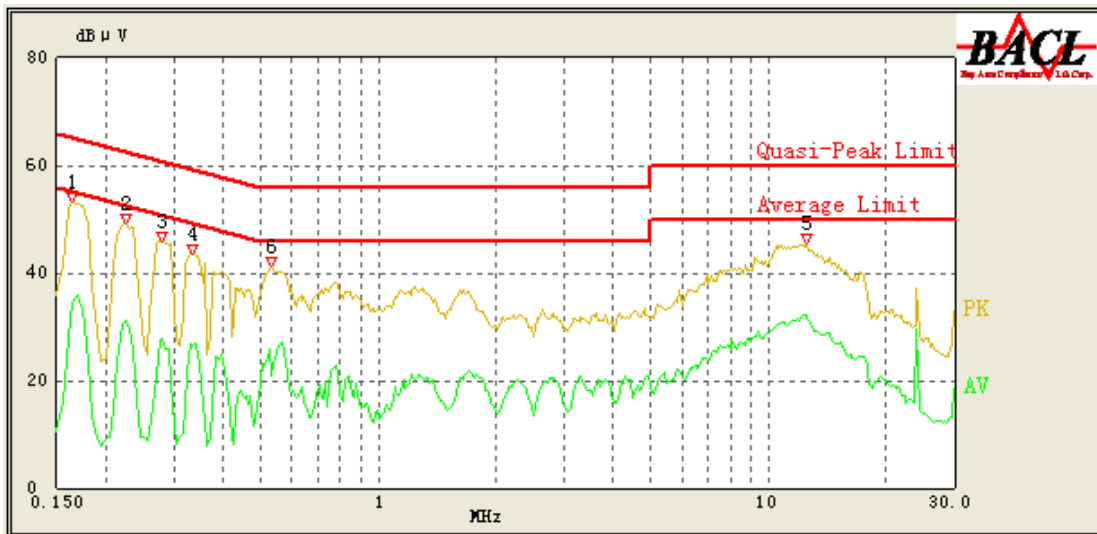

Frequency (MHz)	Corrected Result (dBμV)	Corrected Factor (dB)	Limit (dBμV)	Margin (dB)	Detector (PK /QP/Ave.)
0.165	49.94	10.27	65.57	15.63	QP
12.535	31.55	10.91	50.00	18.45	Ave.
0.225	44.94	10.27	63.86	18.92	QP
0.280	42.49	10.26	62.29	19.80	QP
0.530	35.05	10.25	56.00	20.95	QP
0.165	34.60	10.27	55.57	20.97	Ave.
0.335	39.26	10.26	60.71	21.45	QP
12.535	37.95	10.91	60.00	22.05	QP
0.225	31.17	10.27	53.86	22.69	Ave.
0.335	26.46	10.26	50.71	24.25	Ave.
0.280	27.80	10.26	52.29	24.49	Ave.
0.530	20.88	10.25	46.00	25.12	Ave.

**Neutral:**

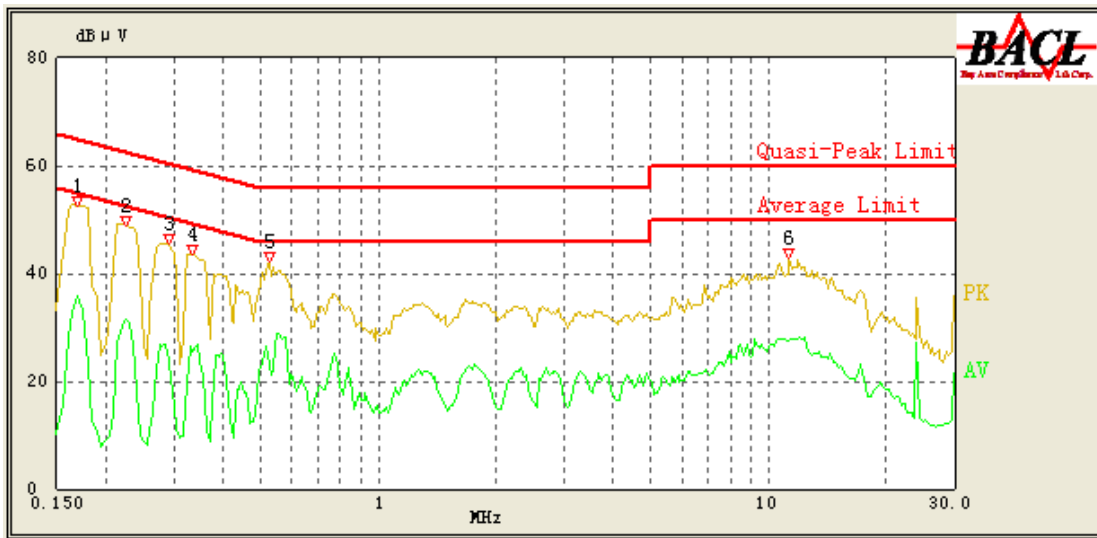

Frequency (MHz)	Corrected Result (dBμV)	Corrected Factor (dB)	Limit (dBμV)	Margin (dB)	Detector (PK /QP/Ave.)
0.170	48.80	10.24	65.43	16.63	QP
0.170	35.99	10.24	55.43	19.44	Ave.
0.525	36.09	10.24	56.00	19.91	QP
0.335	38.84	10.25	60.71	21.87	QP
0.225	31.60	10.24	53.86	22.26	Ave.
11.305	27.38	10.69	50.00	22.62	Ave.
0.225	41.23	10.24	63.86	22.63	QP
0.525	23.09	10.24	46.00	22.91	Ave.
0.290	39.81	10.25	62.00	23.19	QP
11.285	35.60	10.68	60.00	24.40	QP
0.335	25.48	10.25	50.71	25.23	Ave.
0.290	23.94	10.25	52.00	28.06	Ave.

Note:

- 1) Corrected Amplitude = Reading + Correction Factor
- 2) Correction Factor = LISN/ISN VDF (Voltage Division Factor) + Cable Loss + Pulse Limiter Attenuation  
The corrected factor has been input into the transducer of the test software.
- 3) Margin = Limit – Corrected Amplitude



## FCC §15.209, §15.205 & §15.247(d) - SPURIOUS EMISSIONS

### Applicable Standard

FCC §15.247 (d); §15.209; §15.205;

### Measurement Uncertainty

All measurements involve certain levels of uncertainties, especially in field of EMC. The factors contributing to uncertainties are spectrum analyzer, cable loss, antenna factor calibration, antenna directivity, antenna factor variation with height, antenna phase center variation, antenna factor frequency interpolation, measurement distance variation, site imperfections, mismatch (average), and system repeatability.

Based on CISPR 16-4-4, The Treatment of Uncertainty in EMC Measurements, the best estimate of the uncertainty of a radiation emissions measurement at Bay Area Compliance Laboratories Corp. (Shenzhen) is 4.0 dB(k=2, 95% level of confidence), and the uncertainty will not be taken into consideration for all the test data recorded in the report.

### EUT Setup

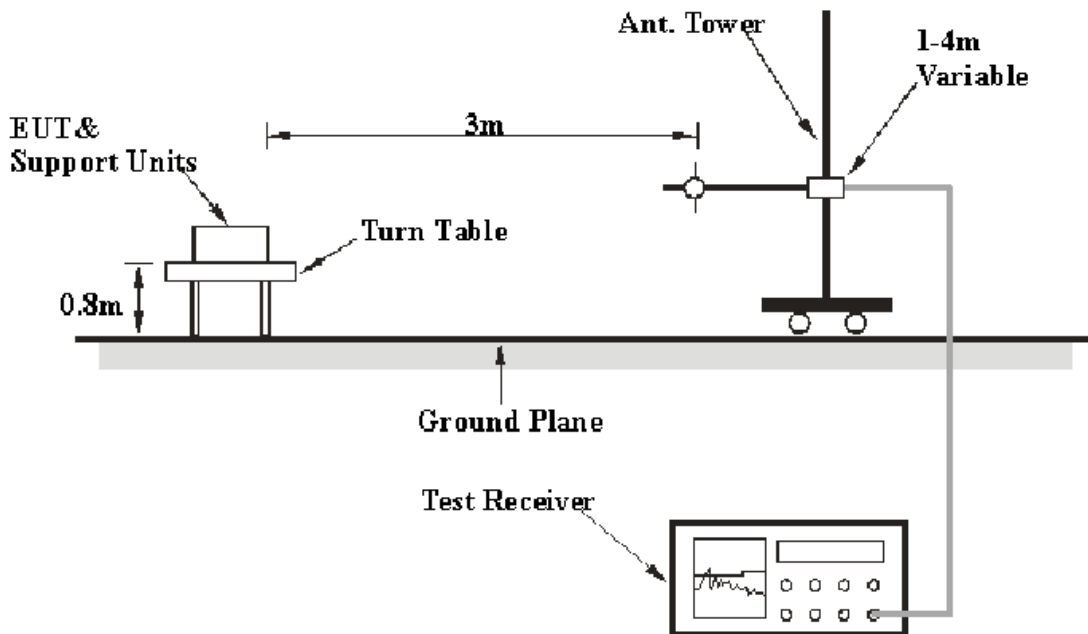

The radiated emission tests were performed in the 3 meters test site, using the setup accordance with the ANSI C63.4-2009. The specification used was the FCC 15.209, and FCC 15.247 limits.

The external I/O cables were draped along the test table and formed a bundle 30 to 40 cm long in the middle.

The spacing between the peripherals was 10 cm.

## EMI Test Receiver & Spectrum Analyzer Setup

The system was investigated from 30 MHz to 25 GHz.

During the radiated emission test, the EMI test receiver & Spectrum Analyzer Setup were set with the following configurations:

<i>Frequency Range</i>	<i>RBW</i>	<i>Video B/W</i>	<i>Detector</i>
30MHz – 1000 MHz	100 kHz	300 kHz	QP
1000 MHz – 25 GHz	1 MHz	3 MHz	PK
1000 MHz – 25 GHz	1 MHz	10 Hz	Ave.

## Test Equipment List and Details

Manufacturer	Description	Model	Serial Number	Calibration Date	Calibration Due Date
HP	Amplifier	8447E	1937A01046	2011-11-24	2012-11-23
Rohde & Schwarz	EMI Test Receiver	ESCI	101122	2012-08-08	2013-08-07
Sunol Sciences	Broadband Antenna	JB1	A040904-2	2011-11-28	2012-11-27
Mini-Circuits	Amplifier	ZVA-213+	N/A	2011-11-24	2012-11-23
Sunol Sciences	Horn Antenna	DRH-118	A052304	2011-12-01	2012-11-30
Rohde & Schwarz	Signal Analyzer	FSIQ26	8386001028	2011-11-24	2012-11-23
the electro-Mechanics Co.	Horn Antenna	3116	9510-2270	2011-10-14	2012-10-13
R&S	Auto test Software	EMC32	V6.30	-	-

\* **Statement of Traceability:** Bay Area Compliance Laboratories Corp. (Shenzhen) attests that all calibrations have been performed in accordance to NVLAP requirements, traceable to the NIST.

## Test Procedure

Maximizing procedure was performed on the highest emissions to ensure that the EUT complied with all installation combinations.

Data was recorded in Quasi-peak detection mode for frequency range of 30 MHz-1 GHz and peak and Average detection modes for frequencies above 1 GHz.

## Corrected Amplitude & Margin Calculation

The Corrected Amplitude is calculated by adding the Antenna Factor and Cable Loss, and subtracting the Amplifier Gain from the Meter Reading. The basic equation is as follows:

$$\text{Corrected Amplitude} = \text{Meter Reading} + \text{Antenna Factor} + \text{Cable Loss} - \text{Amplifier Gain}$$

The “**Margin**” column of the following data tables indicates the degree of compliance with the applicable limit. For example, a margin of 7dB means the emission is 7dB below the limit. The equation for margin calculation is as follows:

$$\text{Margin} = \text{Limit} - \text{Corrected Amplitude}$$

## Test Results Summary

According to the recorded data in following table, the EUT complied with the FCC Title 47, Part 15, Subpart C, section 15.205, 15.209 and 15.247, with the worst margin reading of:

**4.97 dB** at **4924.0 MHz** in the **Vertical** polarization for 802.11b mode, high channel

## Test Data

### Environmental Conditions

<b>Temperature:</b>	23~26 ° C
<b>Relative Humidity:</b>	50~56 %
<b>ATM Pressure:</b>	100.0 kPa

*The testing was performed by Mick Yin from 2012-09-26 to 2012-10-16.*

*Test Mode: Transmitting*

**30 MHz-25 GHz**

**802.11b mode:**

Frequency (MHz)	Receiver		Turntable Degree	Rx Antenna		Corrected Factor (dB)	Corrected Amplitude (dBµV/m)	FCC Part 15.247/15.205/15.209		Comment
	Reading (dBµV/m)	Detector (PK/QP/Ave.)		Height (m)	Polar (H/V)			Limit (dBµV/m)	Margin (dB)	
Low Channel (2412 MHz)										
2412.0	98.98	PK	78	1.1	H	6.13	105.11	/	/	Fund.
2412.0	94.32	Ave.	78	1.1	H	6.13	100.45	/	/	Fund.
2412.0	95.08	PK	61	1.3	V	6.13	101.21	/	/	Fund.
2412.0	90.48	Ave.	61	1.3	V	6.13	96.61	/	/	Fund.
4824.0	35.07	Ave.	93	1.4	V	12.40	47.47	54	6.53	Harmonic
265.3	47.9	QP	89	1.6	H	-15.4	32.5	46	13.50	Spurious
2370.4	32.74	Ave.	115	1.1	H	5.48	38.22	54	15.78	Spurious
2386.2	31.39	Ave.	274	1.2	V	6.13	37.52	54	16.48	Spurious
2497.8	27.44	Ave.	35	1.1	H	7.21	34.65	54	19.35	Spurious
4824.0	40.33	PK	93	1.4	V	12.40	52.73	74	21.27	Harmonic
2370.4	44.02	PK	115	1.1	H	5.48	49.50	74	24.50	Spurious
2497.8	41.68	PK	35	1.1	H	7.21	48.89	74	25.11	Spurious
2386.2	42.59	PK	274	1.2	V	6.13	48.72	74	25.28	Spurious
9648.0	31.44	PK	221	1.5	V	19.29	50.73	85.11	34.38	Harmonic
7236.0	33.28	PK	68	1.2	V	16.62	49.90	85.11	35.21	Harmonic
9648.0	17.51	Ave.	221	1.5	V	19.29	36.80	80.45	43.65	Harmonic
7236.0	19.43	Ave.	68	1.2	V	16.62	36.05	80.45	44.40	Harmonic
Middle Channel (2437 MHz)										
2437.0	100.01	PK	83	1.1	H	6.13	106.14	/	/	Fund.
2437.0	95.35	Ave.	83	1.1	H	6.13	101.48	/	/	Fund.
2437.0	94.93	PK	176	1.3	V	6.13	101.06	/	/	Fund.
2437.0	90.29	Ave.	176	1.3	V	6.13	96.42	/	/	Fund.
4874.0	31.49	Ave.	39	1.2	H	12.46	43.95	54.00	10.05	Harmonic
265.3	49.1	QP	132	1.6	H	-15.4	33.7	46	12.30	Spurious
2356.9	29.27	Ave.	224	1.2	V	5.48	34.75	54.00	19.25	Spurious
7311.0	17.53	Ave.	153	1.6	H	16.49	34.02	54.00	19.98	Harmonic
2492.6	25.54	Ave.	77	1.3	H	7.21	32.75	54.00	21.25	Spurious
2318.2	26.82	Ave.	46	1.1	V	5.48	32.30	54.00	21.70	Spurious
4874.0	37.49	PK	39	1.2	H	12.46	49.95	74.00	24.05	Harmonic
7311.0	31.64	PK	153	1.6	H	16.49	48.13	74.00	25.87	Harmonic
2492.6	39.44	PK	77	1.3	H	7.21	46.65	74.00	27.35	Spurious
2356.9	39.96	PK	224	1.2	V	5.48	45.44	74.00	28.56	Spurious
2318.2	37.85	PK	46	1.1	V	5.48	43.33	74.00	30.67	Spurious
9748.0	31.44	PK	164	1.1	H	19.40	50.84	86.14	35.30	Harmonic
9748.0	16.99	Ave.	164	1.1	H	19.40	36.39	81.48	45.09	Harmonic

Frequency (MHz)	Receiver		Turntable Degree	Rx Antenna		Corrected Factor (dB)	Corrected Amplitude (dBµV/m)	FCC Part 15.247/15.205/15.209		
	Reading (dBµV/m)	Detector (PK/QP/Ave.)		Height (m)	Polar (H/V)			Limit (dBµV/m)	Margin (dB)	Comment
High Channel (2462 MHz)										
2462.0	100.61	PK	35	1.3	H	7.21	107.82	/	/	Fund.
2462.0	95.83	Ave.	35	1.3	H	7.21	103.04	/	/	Fund.
2462.0	96.46	PK	44	1.2	V	7.21	103.67	/	/	Fund.
2462.0	91.93	Ave.	44	1.2	V	7.21	99.14	/	/	Fund.
4924.0	36.53	Ave.	96	1.3	V	12.50	49.03	54	4.97	Harmonic
2483.5	37.64	Ave.	71	1.6	H	7.21	44.85	54	9.15	Spurious
2498.3	34.08	Ave.	68	1.1	H	7.21	41.29	54	12.71	Spurious
265.3	47.3	QP	156	1.6	H	-15.4	31.9	46	14.1	Spurious
2483.5	47.43	PK	71	1.6	H	7.21	54.64	74	19.36	Spurious
7386.0	18.02	Ave.	156	1.2	H	15.91	33.93	54	20.07	Harmonic
4924.0	40.52	PK	96	1.3	V	12.50	53.02	74	20.98	Harmonic
2498.3	44.72	PK	68	1.1	H	7.21	51.93	74	22.07	Spurious
7386.0	32.43	PK	156	1.2	H	15.91	48.34	74	25.66	Harmonic
2346.7	18.71	Ave.	135	1.5	V	5.48	24.19	54	29.81	Spurious
2346.7	32.63	PK	135	1.5	V	5.48	38.11	74	35.89	Spurious
9848.0	32.49	PK	74	1.1	H	19.39	51.88	87.82	35.94	Harmonic
9848.0	17.22	Ave.	74	1.1	H	19.39	36.61	83.04	46.43	Harmonic

**802.11g mode:**

Frequency (MHz)	Receiver		Turntable Degree	Rx Antenna		Corrected Factor (dB)	Corrected Amplitude (dBµV/m)	FCC Part 15.247/15.205/15.209		Comment
	Reading (dBµV/m)	Detector (PK/QP/Ave.)		Height (m)	Polar (H/V)			Limit (dBµV/m)	Margin (dB)	
Low Channel (2412 MHz)										
2412.0	97.94	PK	88	1.2	H	6.13	104.07	/	/	Fund.
2412.0	85.96	Ave.	88	1.2	H	6.13	92.09	/	/	Fund.
2412.0	94.10	PK	13	1.3	V	6.13	100.23	/	/	Fund.
2412.0	80.85	Ave.	13	1.3	V	6.13	86.98	/	/	Fund.
265.3	48.4	QP	211	1.6	H	-15.4	33.00	46	13.00	Spurious
4824.0	28.01	Ave.	74	1.0	V	12.40	40.41	54	13.59	Harmonic
2388.7	32.86	Ave.	117	1.2	H	6.13	38.99	54	15.01	Spurious
2335.2	32.03	Ave.	58	1.5	H	5.48	37.51	54	16.49	Spurious
2388.7	48.04	PK	117	1.2	H	6.13	54.17	74	19.83	Spurious
2494.9	25.75	Ave.	96	1.1	H	7.21	32.96	54	21.04	Spurious
2335.2	45.25	PK	58	1.5	H	5.48	50.73	74	23.27	Spurious
4824.0	36.74	PK	74	1.0	V	12.40	49.14	74	24.86	Harmonic
2494.9	39.66	PK	96	1.1	H	7.21	46.87	74	27.13	Spurious
9648.0	30.64	PK	225	1.3	V	19.29	49.93	84.07	34.14	Harmonic
7236.0	32.32	PK	136	1.1	H	16.62	48.94	84.07	35.13	Harmonic
9648.0	16.99	Ave.	225	1.3	V	19.29	36.28	72.09	35.81	Harmonic
7236.0	17.68	Ave.	136	1.1	H	16.62	34.30	72.09	37.79	Harmonic
Middle Channel (2437 MHz)										
2437.0	96.08	PK	38	1.3	H	7.21	103.29	/	/	Fund.
2437.0	84.34	Ave.	38	1.3	H	7.21	91.55	/	/	Fund.
2437.0	92.33	PK	223	1.2	V	7.21	99.54	/	/	Fund.
2437.0	83.12	Ave.	223	1.2	V	7.21	90.33	/	/	Fund.
4874.0	30.08	Ave.	132	1.3	H	12.46	42.54	54	11.46	Harmonic
265.3	48.2	QP	145	1.6	H	-15.4	32.80	46	13.20	Spurious
7311.0	18.04	Ave.	168	1.2	H	16.49	34.53	54	19.47	Harmonic
2389.3	24.08	Ave.	31	1.1	H	6.13	30.21	54	23.79	Spurious
2483.9	22.76	Ave.	58	1.2	H	7.21	29.97	54	24.03	Spurious
4874.0	37.24	PK	132	1.3	H	12.46	49.70	74	24.30	Harmonic
7311.0	32.59	PK	168	1.2	H	16.49	49.08	74	24.92	Harmonic
2498.7	21.24	Ave.	13	1.1	H	7.59	28.83	54	25.17	Spurious
2389.3	42.27	PK	31	1.1	H	6.13	48.40	74	25.60	Spurious
2498.7	40.69	PK	13	1.1	H	7.59	48.28	74	25.72	Spurious
2483.9	40.52	PK	58	1.2	H	7.21	47.73	74	26.27	Spurious
9748.0	32.27	PK	31	1.1	H	19.40	51.67	83.29	31.62	Harmonic
9748.0	17.42	Ave.	31	1.1	H	19.40	36.82	71.55	34.73	Harmonic

Frequency (MHz)	Receiver		Turntable Degree	Rx Antenna		Corrected Factor (dB)	Corrected Amplitude (dB $\mu$ V/m)	FCC Part 15.247/15.205/15.209		
	Reading (dB $\mu$ V/m)	Detector (PK/QP/Ave.)		Height (m)	Polar (H/V)			Limit (dB $\mu$ V/m)	Margin (dB)	Comment
High Channel (2462 MHz)										
2462.0	98.51	PK	35	1.3	H	7.21	105.72	/	/	Fund.
2462.0	85.95	Ave.	35	1.3	H	7.21	93.16	/	/	Fund.
2462.0	94.67	PK	112	1.2	V	7.21	101.88	/	/	Fund.
2462.0	81.82	Ave.	112	1.2	V	7.21	89.03	/	/	Fund.
4924.0	30.24	Ave.	115	1.1	H	12.50	42.74	54	11.26	Harmonic
265.3	48.5	QP	89	1.6	H	-15.4	33.10	46	12.90	Spurious
2483.8	31.61	Ave.	135	1.4	H	7.21	38.82	54	15.18	Spurious
2483.8	48.71	PK	135	1.4	H	7.21	55.92	74	18.08	Spurious
7386.0	19.03	Ave.	235	1.3	H	15.91	34.94	54	19.06	Harmonic
2385.3	27.24	Ave.	87	1.2	V	6.13	33.37	54	20.63	Spurious
2382.9	27.11	Ave.	35	1.1	V	6.13	33.24	54	20.76	Spurious
4924.0	38.93	PK	115	1.1	H	12.50	51.43	74	22.57	Harmonic
7386.0	32.59	PK	235	1.3	H	15.91	48.50	74	25.50	Harmonic
2382.9	41.65	PK	35	1.1	V	6.13	47.78	74	26.22	Spurious
2385.3	41.47	PK	87	1.2	V	6.13	47.60	74	26.40	Spurious
9848.0	31.93	PK	168	1.2	H	19.39	51.32	85.72	34.40	Harmonic
9848.0	18.04	Ave.	168	1.2	H	19.39	37.43	73.16	35.73	Harmonic

**802.11n-HT20 mode:**

Frequency (MHz)	Receiver		Turntable Degree	Rx Antenna		Corrected Factor (dB)	Corrected Amplitude (dBµV/m)	FCC Part 15.247/15.205/15.209		Comment
	Reading (dBµV/m)	Detector (PK/QP/Ave.)		Height (m)	Polar (H/V)			Limit (dBµV/m)	Margin (dB)	
Low Channel (2412 MHz)										
2412.0	98.06	PK	78	1.1	H	6.13	104.19	/	/	Fund.
2412.0	84.32	Ave.	78	1.1	H	6.13	90.45	/	/	Fund.
2412.0	94.59	PK	112	1.3	V	6.13	100.72	/	/	Fund.
2412.0	80.02	Ave.	112	1.3	V	6.13	86.15	/	/	Fund.
4824.0	31.11	Ave.	254	1.2	H	12.40	43.51	54	10.49	Harmonic
265.3	49	QP	241	1.6	H	-15.4	33.60	46	12.40	Spurious
2485.6	27.69	Ave.	49	1.3	H	7.21	34.90	54	19.10	Spurious
4824.0	39.06	PK	254	1.2	H	12.40	51.46	74	22.54	Harmonic
2485.6	43.55	PK	49	1.3	H	7.21	50.76	74	23.24	Spurious
2330.1	22.49	Ave.	97	1.2	V	5.48	27.97	54	26.03	Spurious
2372.6	21.77	Ave.	33	1.1	V	6.13	27.90	54	26.10	Spurious
2330.1	38.41	PK	97	1.2	V	5.48	43.89	74	30.11	Spurious
2372.6	37.59	PK	33	1.1	V	6.13	43.72	74	30.28	Spurious
9648.0	31.73	PK	42	1.2	H	19.29	51.02	84.19	33.17	Harmonic
9648.0	17.93	Ave.	42	1.2	H	19.29	37.22	70.45	33.23	Harmonic
7236.0	32.04	PK	87	1.1	H	16.62	48.66	84.19	35.53	Harmonic
7236.0	18.06	Ave.	87	1.1	H	16.62	34.68	70.45	35.77	Harmonic
Middle Channel (2437 MHz)										
2437.0	96.58	PK	76	1.1	H	7.21	103.79	/	/	Fund.
2437.0	84.29	Ave.	76	1.1	H	7.21	91.50	/	/	Fund.
2437.0	94.14	PK	114	1.2	V	7.21	101.35	/	/	Fund.
2437.0	82.67	Ave.	114	1.2	V	7.21	89.88	/	/	Fund.
4874.0	30.11	Ave.	59	1.3	H	12.46	42.57	54	11.43	Harmonic
265.3	49.4	QP	231	1.6	H	-15.4	34.00	46	12.00	Spurious
7311.0	19.43	Ave.	71	1.4	H	16.49	35.92	54	18.08	Harmonic
2485.6	26.59	Ave.	38	1.1	H	7.21	33.80	54	20.20	Spurious
2355.2	28.23	Ave.	96	1.4	H	5.48	33.71	54	20.29	Spurious
4874.0	38.32	PK	59	1.3	H	12.46	50.78	74	23.22	Harmonic
2493.7	23.12	Ave.	142	1.2	V	7.21	30.33	54	23.67	Spurious
7311.0	32.19	PK	71	1.4	H	16.49	48.68	74	25.32	Harmonic
2485.6	40.73	PK	38	1.1	H	7.21	47.94	74	26.06	Spurious
2355.2	41.71	PK	96	1.4	H	5.48	47.19	74	26.81	Spurious
2493.7	36.43	PK	142	1.2	V	7.21	43.64	74	30.36	Spurious
9748.0	31.83	PK	233	1.1	H	19.40	51.23	83.79	32.56	Harmonic
9748.0	18.77	Ave.	233	1.1	H	19.40	38.17	71.50	33.33	Harmonic



Frequency (MHz)	Receiver		Turntable Degree	Rx Antenna		Corrected Factor (dB)	Corrected Amplitude (dBµV/m)	FCC Part 15.247/15.205/15.209		
	Reading (dBµV/m)	Detector (PK/QP/Ave.)		Height (m)	Polar (H/V)			Limit (dBµV/m)	Margin (dB)	Comment
High Channel (2462 MHz)										
2462.0	97.54	PK	71	1.2	H	7.21	104.75	/	/	Fund.
2462.0	85.87	Ave.	71	1.2	H	7.21	93.08	/	/	Fund.
2462.0	94.14	PK	224	1.1	V	7.21	101.35	/	/	Fund.
2462.0	81.03	Ave.	224	1.1	V	7.21	88.24	/	/	Fund.
4924.0	30.03	Ave.	187	1.1	H	12.50	42.53	54	11.47	Harmonic
265.3	47.2	QP	162	1.6	H	-15.4	31.80	46	14.20	Spurious
2495.6	30.36	Ave.	46	1.5	V	7.21	37.57	54	16.43	Spurious
2484.2	29.93	Ave.	73	1.4	V	7.21	37.14	54	16.86	Spurious
7386.0	19.03	Ave.	226	1.3	H	15.91	34.94	54	19.06	Harmonic
4924.0	37.69	PK	187	1.1	H	12.50	50.19	74	23.81	Harmonic
2332.5	23.71	Ave.	98	1.3	H	5.48	29.19	54	24.81	Spurious
2484.2	41.32	PK	73	1.4	V	7.21	48.53	74	25.47	Spurious
7386.0	32.44	PK	226	1.3	H	15.91	48.35	74	25.65	Harmonic
2495.6	39.97	PK	46	1.5	V	7.21	47.18	74	26.82	Spurious
2332.5	35.41	PK	98	1.3	H	5.48	40.89	74	33.11	Spurious
9848.0	31.09	PK	98	1.2	H	19.39	50.48	84.75	34.27	Harmonic
9848.0	18.72	Ave.	98	1.2	H	19.39	38.11	73.08	34.97	Harmonic

Note:

Corrected Amplitude = Corrected Factor + Reading

Corrected Factor = Antenna factor (RX) + cable loss – amplifier factor

Margin = Limit - Corrected Amplitude

### Conducted Spurious Emissions at Antenna Port:

#### 802.11b Low Channel

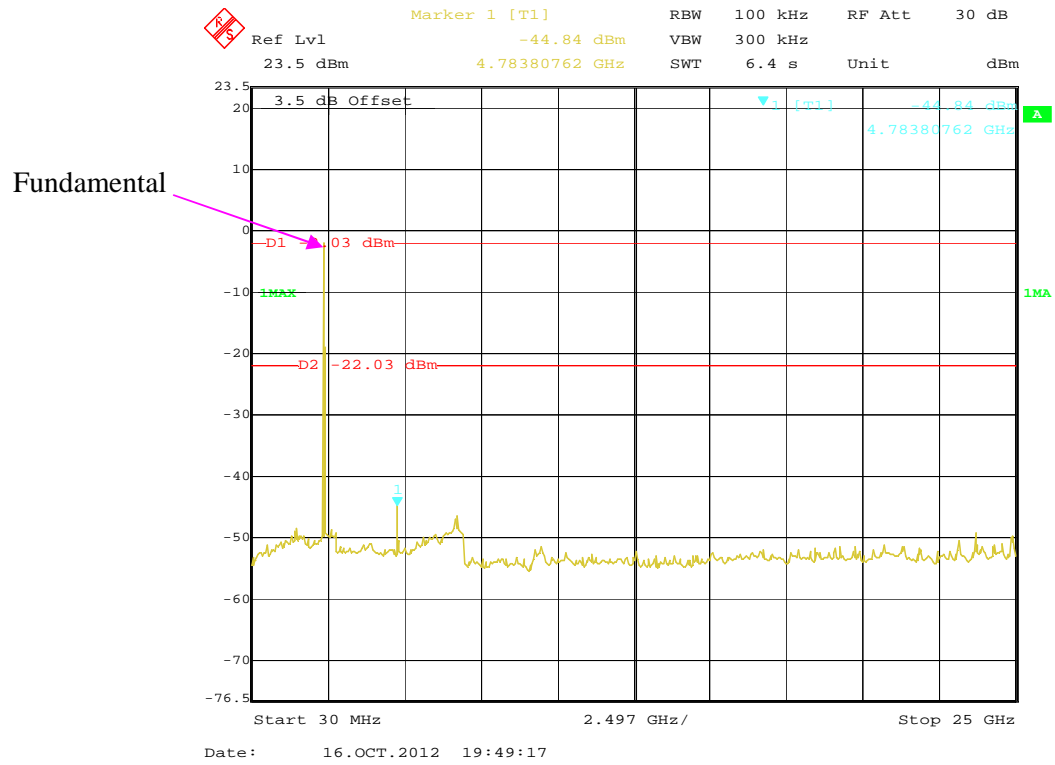

#### 802.11b Middle Channel

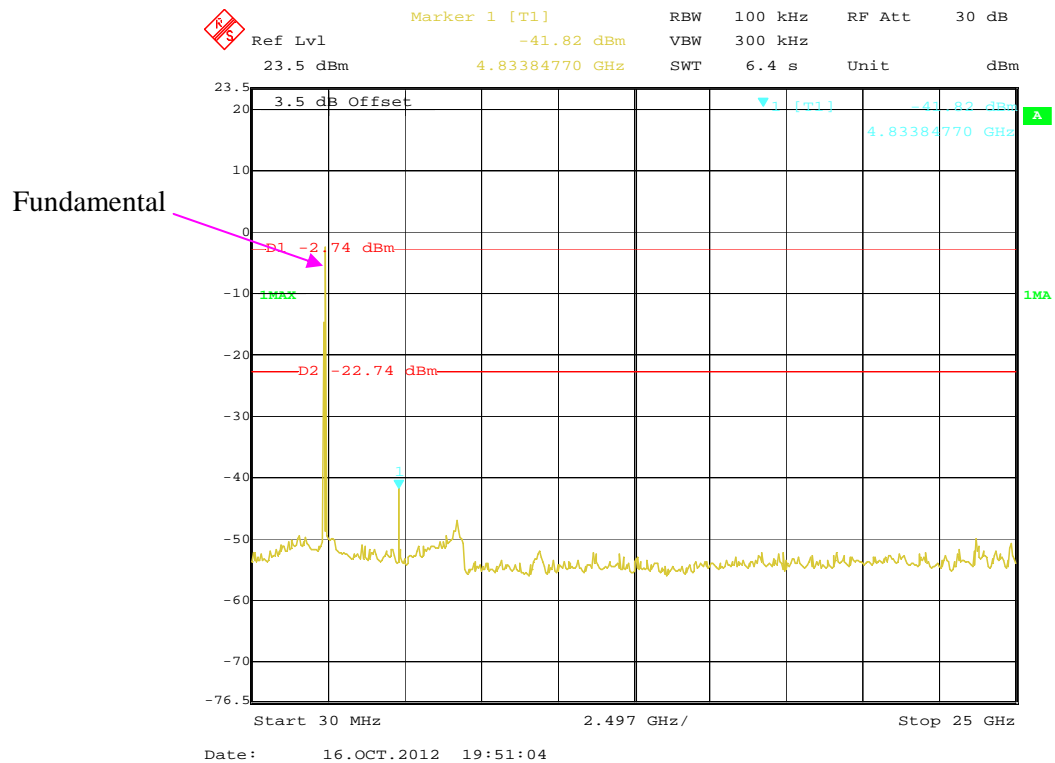

### 802.11b High Channel

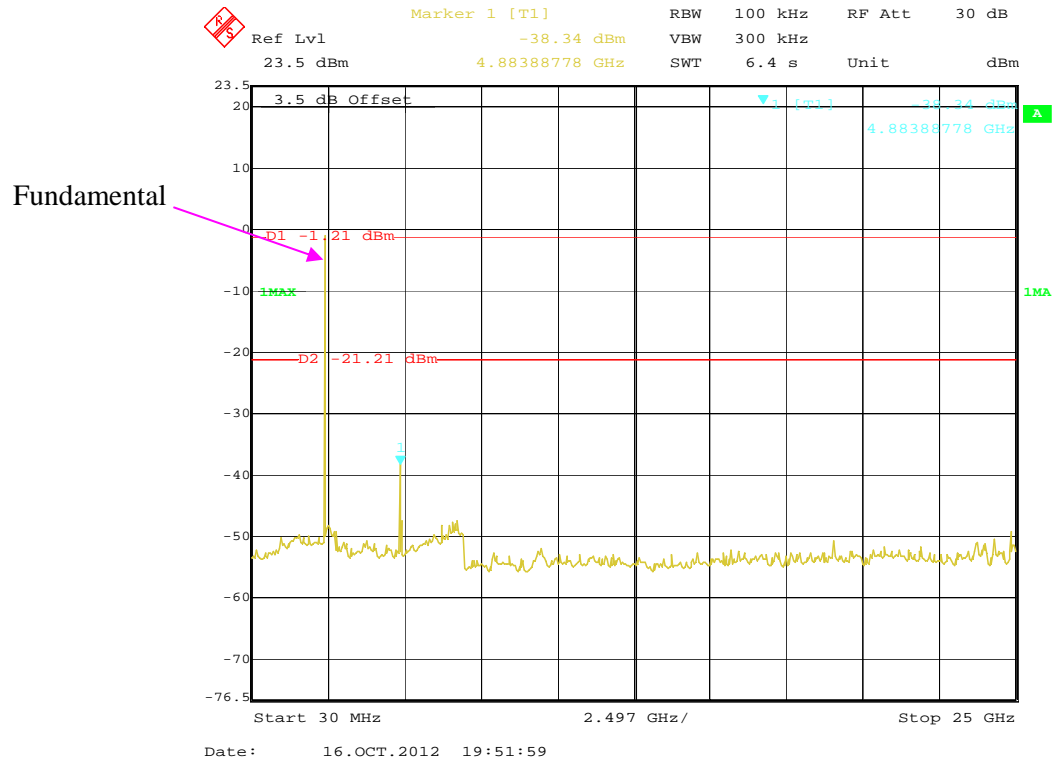

### 802.11g Low Channel

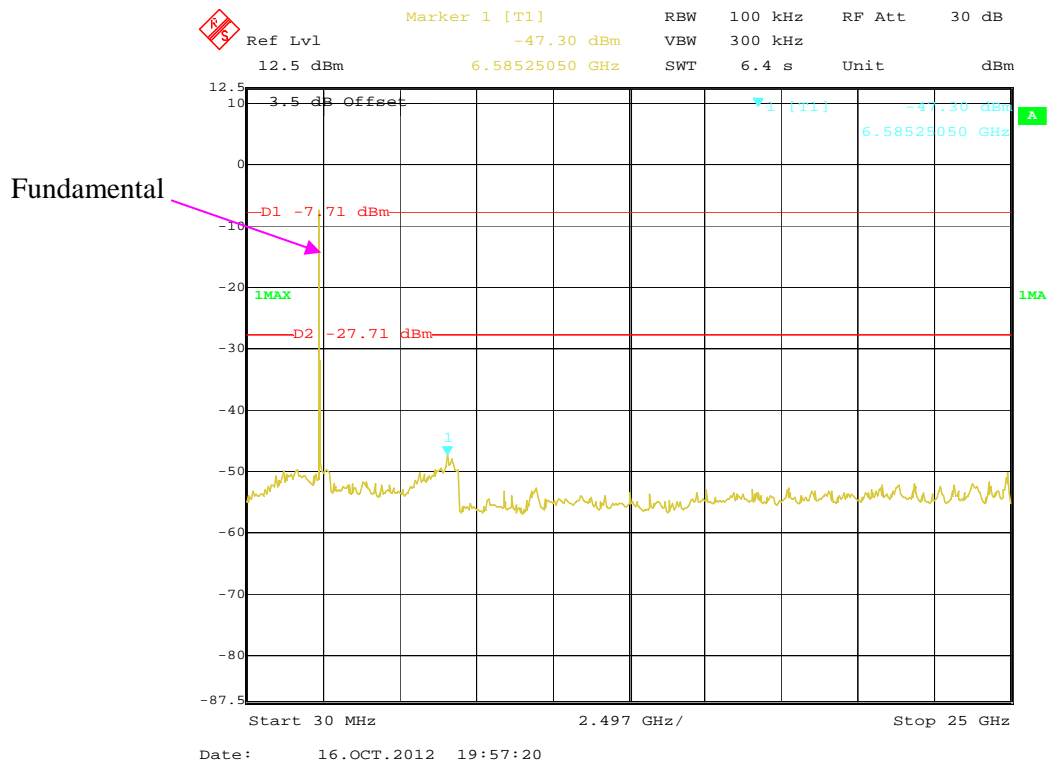

### 802.11g Middle Channel

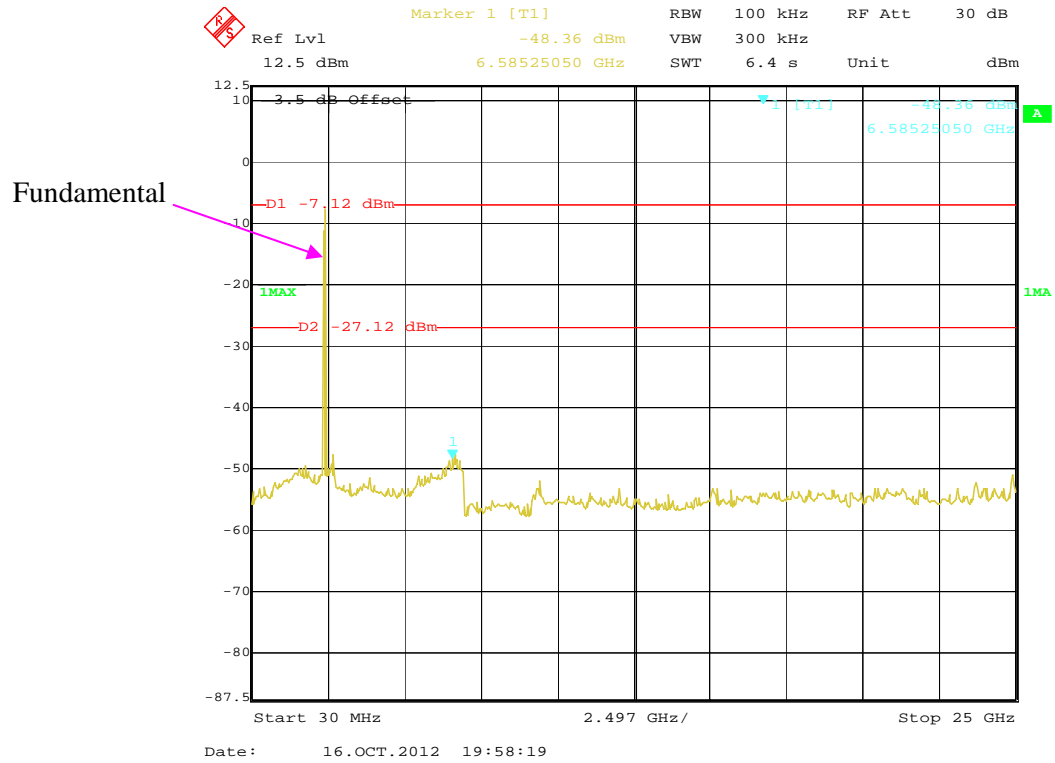

### 802.11g High Channel

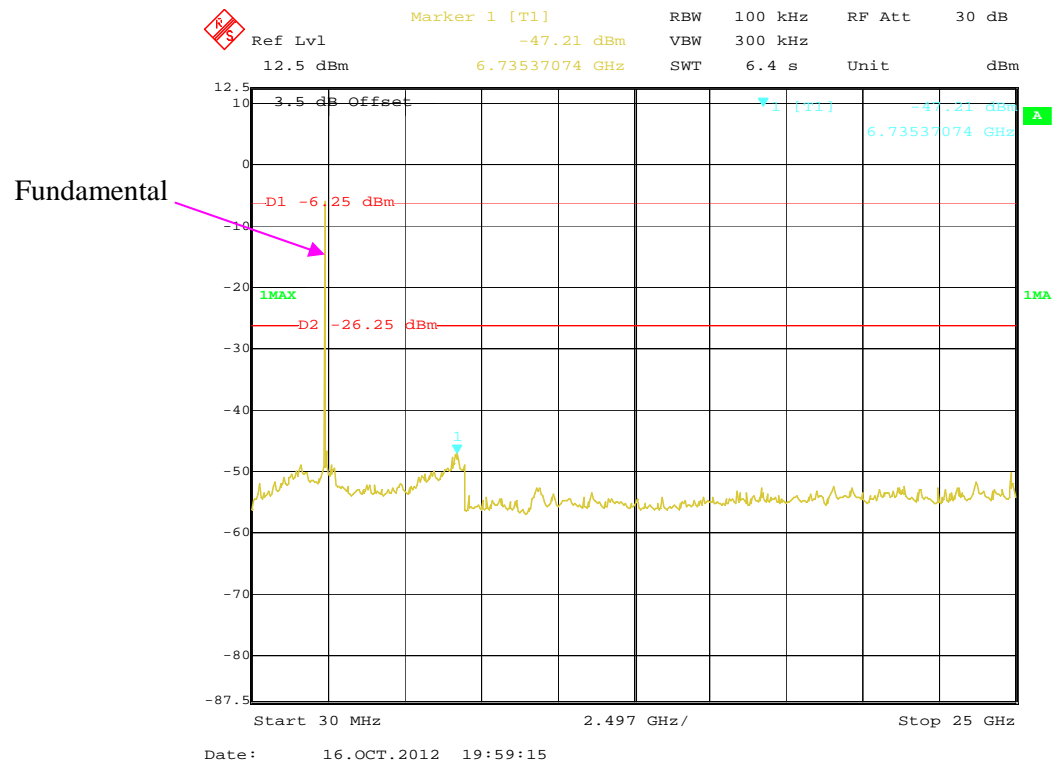

### 802.11n-HT20 Low Channel

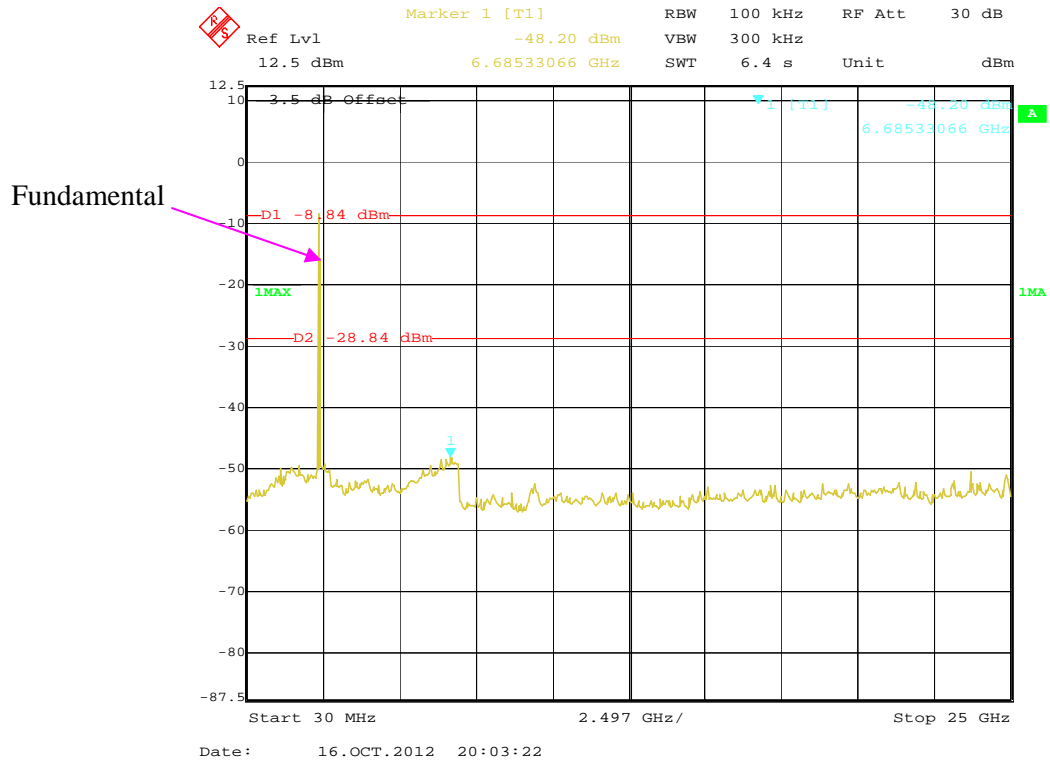

### 802.11n-HT20 Middle Channel

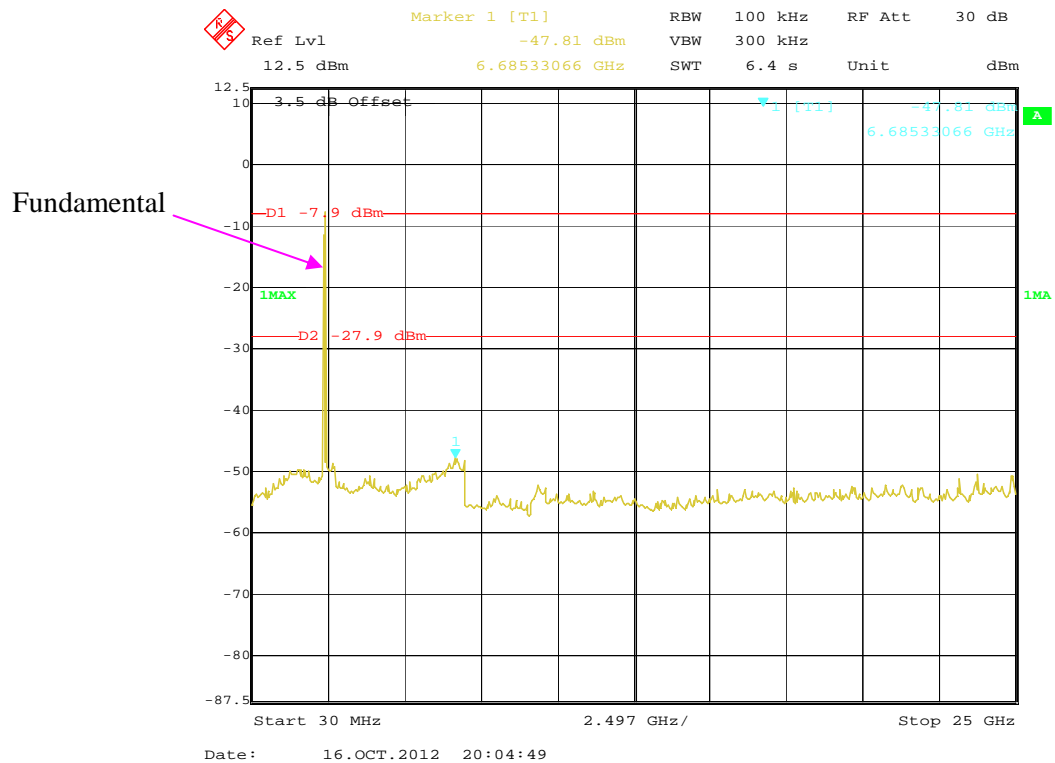

### 802.11n-HT20 High Channel

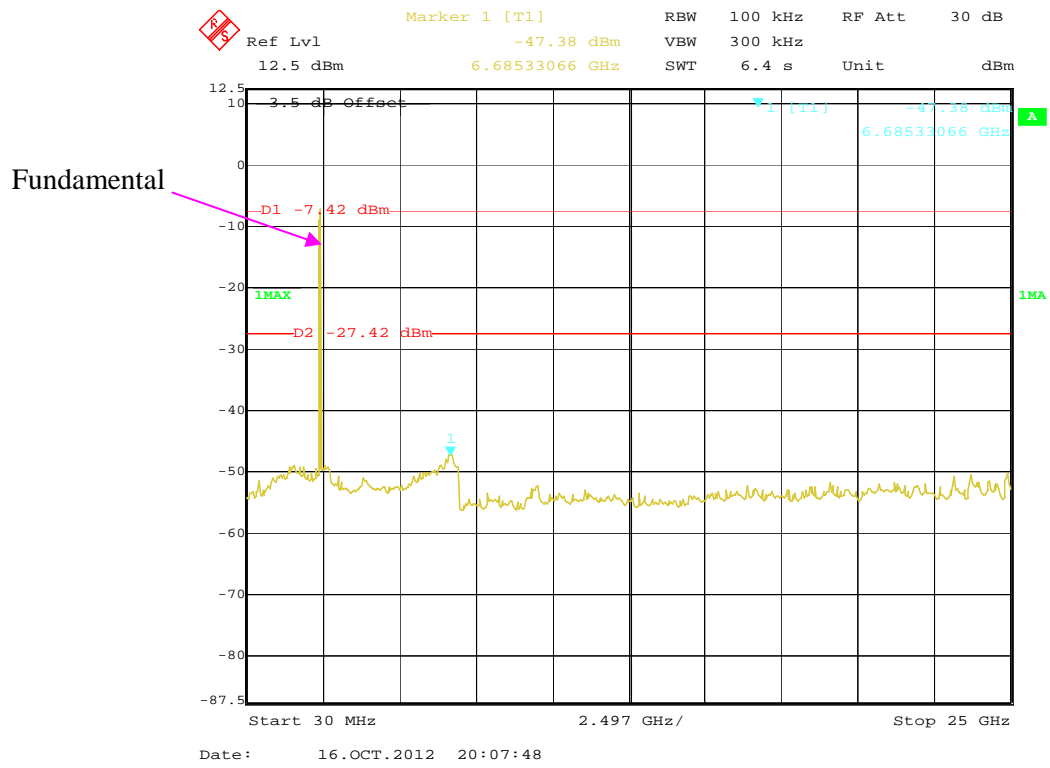

## FCC §15.247(a) (2) – 6 dB BANDWIDTH TESTING

### Applicable Standard

Systems using digital modulation techniques may operate in the 902–928 MHz, 2400–2483.5 MHz, and 5725–5850 MHz bands. The minimum 6 dB bandwidth shall be at least 500 kHz.

### Test Equipment List and Details

Manufacturer	Description	Model	Serial Number	Calibration Date	Calibration Due Date
Rohde & Schwarz	EMI Test Receiver	ESCI	101122	2012-08-08	2013-08-07

\* **Statement of Traceability:** Bay Area Compliance Laboratories Corp. (Shenzhen) attests that all calibrations have been performed in accordance to NVLAP requirements, traceable to the NIST.

### Test Procedure

1. Check the calibration of the measuring instrument using either an internal calibrator or a known signal from an external generator.
2. Position the EUT without connection to measurement instrument. Turn on the EUT and connect it to measurement instrument. Then set it to any one convenient frequency within its operating range. Set a reference level on the measuring instrument equal to the highest peak value.
3. Measure the frequency difference of two frequencies that were attenuated 6 dB from the reference level. Record the frequency difference as the emission bandwidth.
4. Repeat above procedures until all frequencies measured were complete.

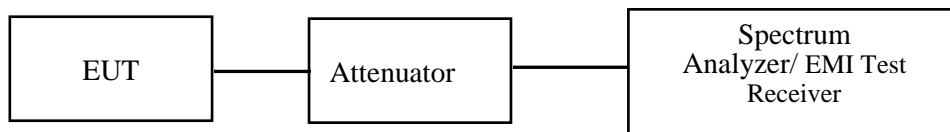

### Test Data

#### Environmental Conditions

<b>Temperature:</b>	25 °C
<b>Relative Humidity:</b>	56 %
<b>ATM Pressure:</b>	100.0 kPa

*The testing was performed by Mick Yin on 2012-10-09.*

*Test Mode: Transmitting*

**Test Result:** Pass.

Please refer to the following tables and plots.

Channel	Frequency (MHz)	Data Rate (Mbps)	6dB bandwidth (MHz)	Limit (kHz)	Result
<b>802.11b mode</b>					
Low	2412	1	10.24	$\geq 500$	Pass
Middle	2437	1	10.24	$\geq 500$	Pass
High	2462	1	10.24	$\geq 500$	Pass
<b>802.11g mode</b>					
Low	2412	6	16.64	$\geq 500$	Pass
Middle	2437	6	16.64	$\geq 500$	Pass
High	2462	6	16.64	$\geq 500$	Pass
<b>802.11n-HT20 mode</b>					
Low	2412	6.5	17.76	$\geq 500$	Pass
Middle	2437	6.5	17.76	$\geq 500$	Pass
High	2462	6.5	17.76	$\geq 500$	Pass



### 802.11b Low Channel

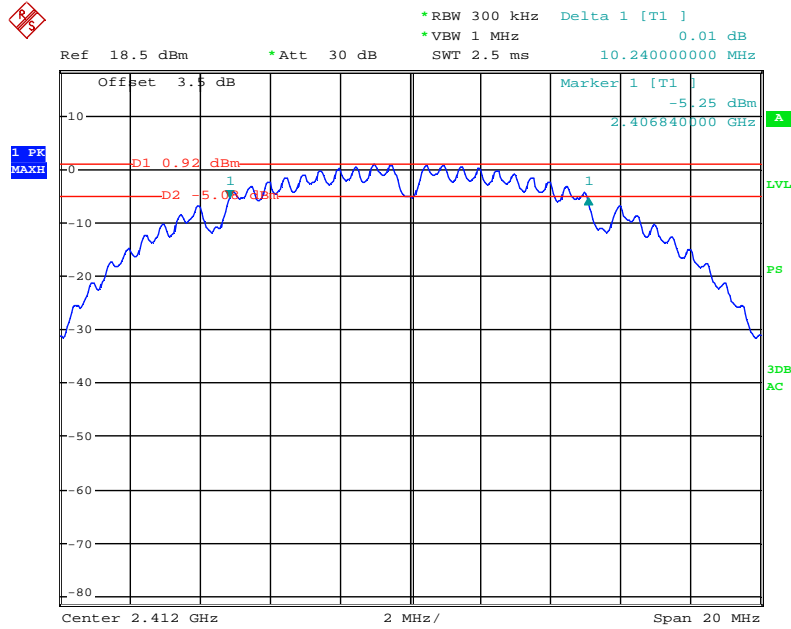

Date: 9.OCT.2012 22:11:40

### 802.11b Middle Channel

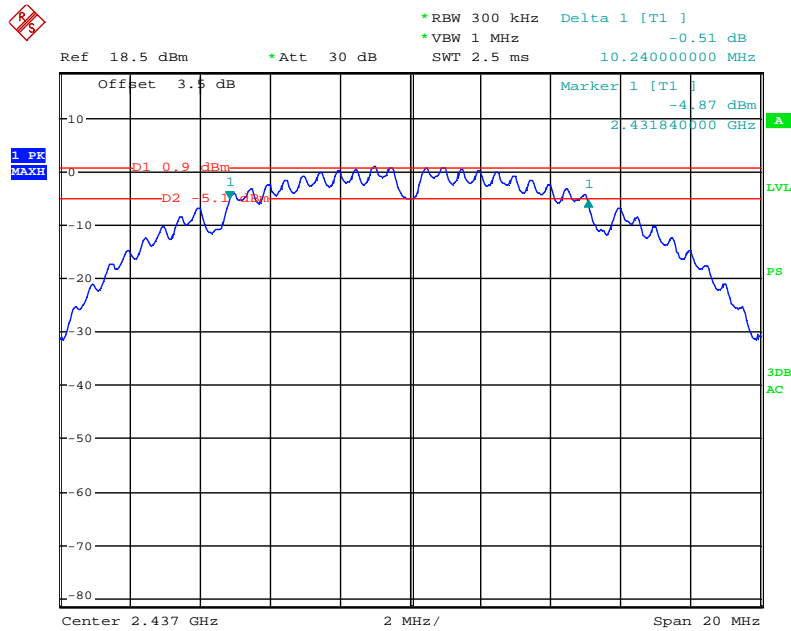

Date: 9.OCT.2012 22:12:25

### 802.11b High Channel

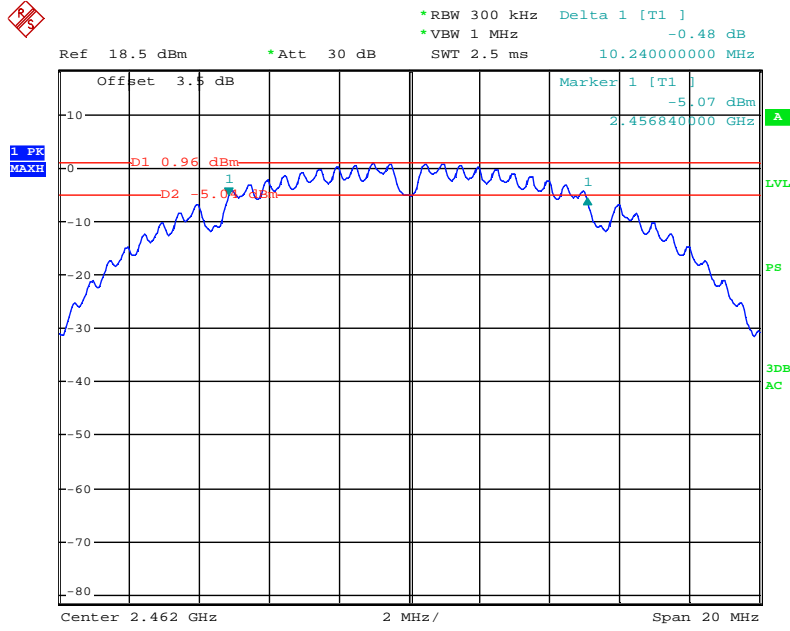

Date: 9.OCT.2012 22:13:11

### 802.11g Low Channel

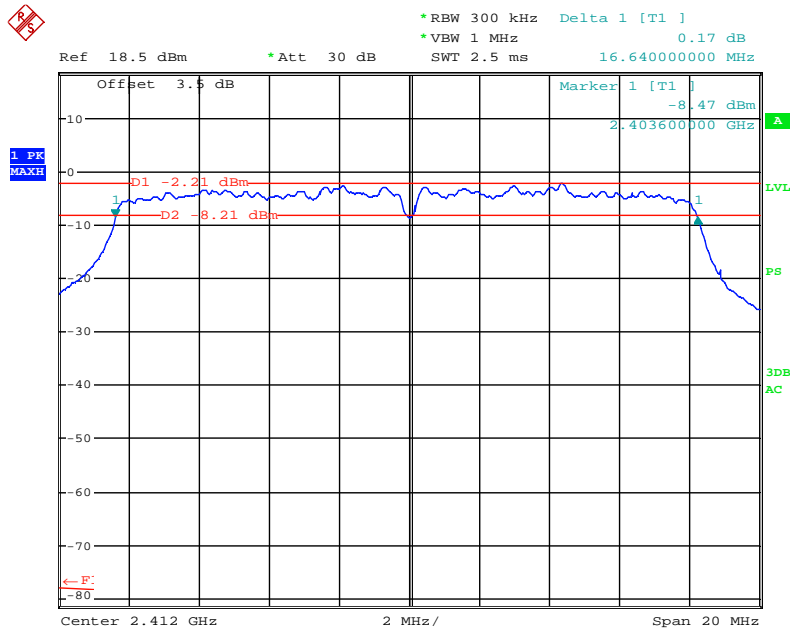

Date: 9.OCT.2012 22:37:54

### 802.11g Middle Channel

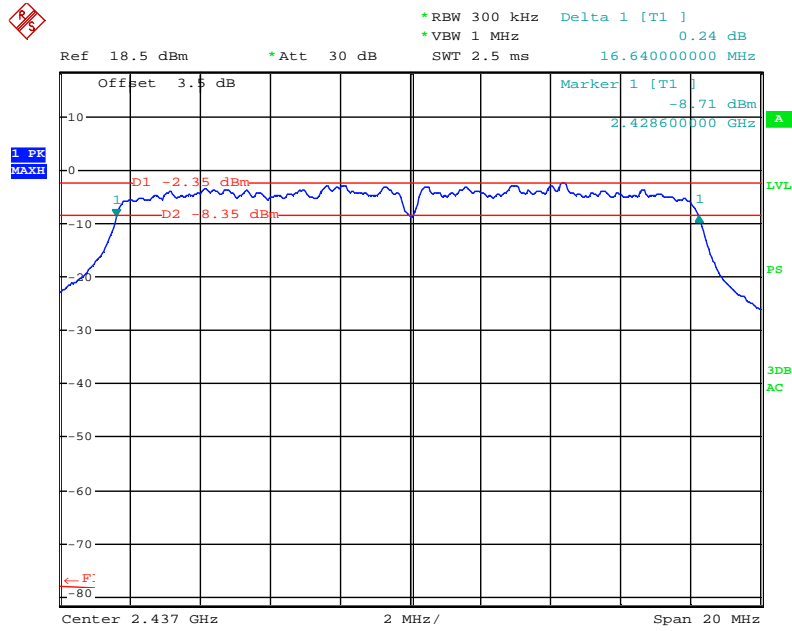

Date: 9.OCT.2012 22:39:01

### 802.11g High Channel

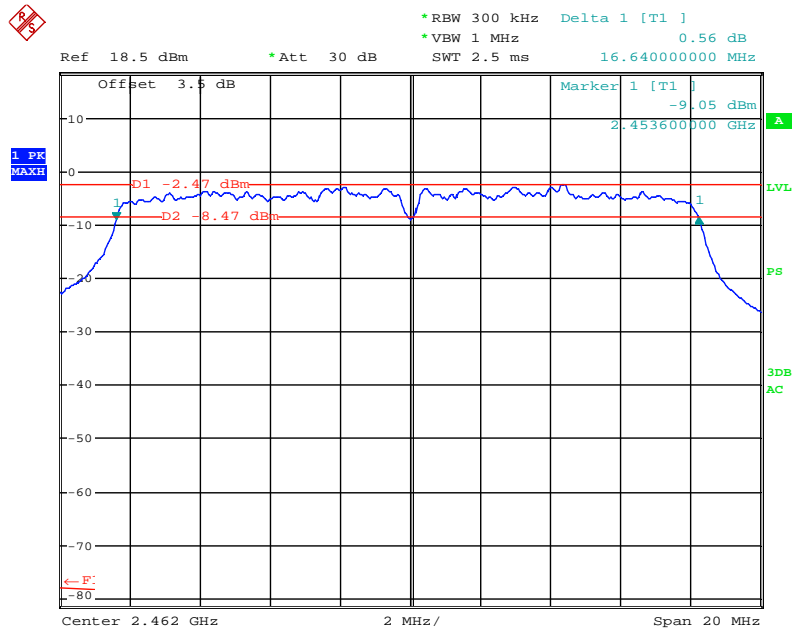

Date: 9.OCT.2012 22:39:40

### 802.11n-HT20 Low Channel

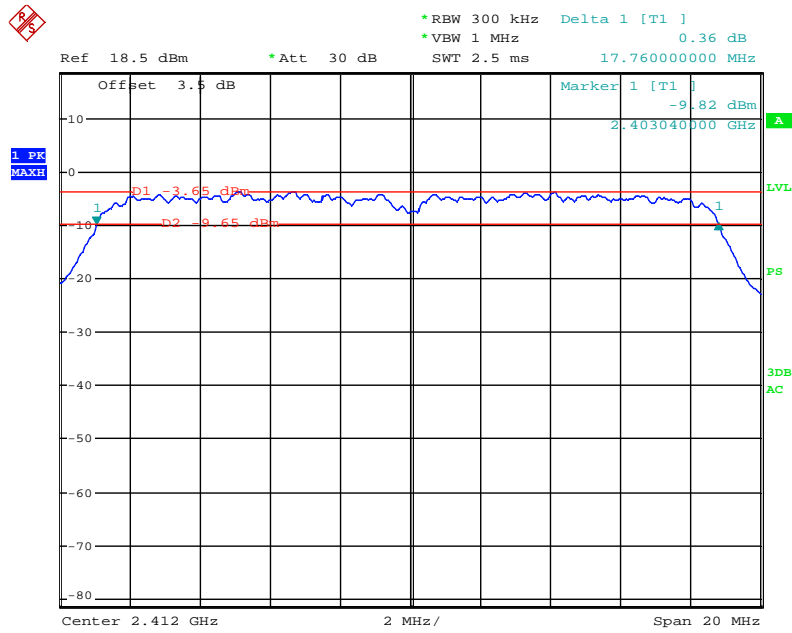

Date: 9.OCT.2012 22:56:57

### 802.11n-HT20 Middle Channel

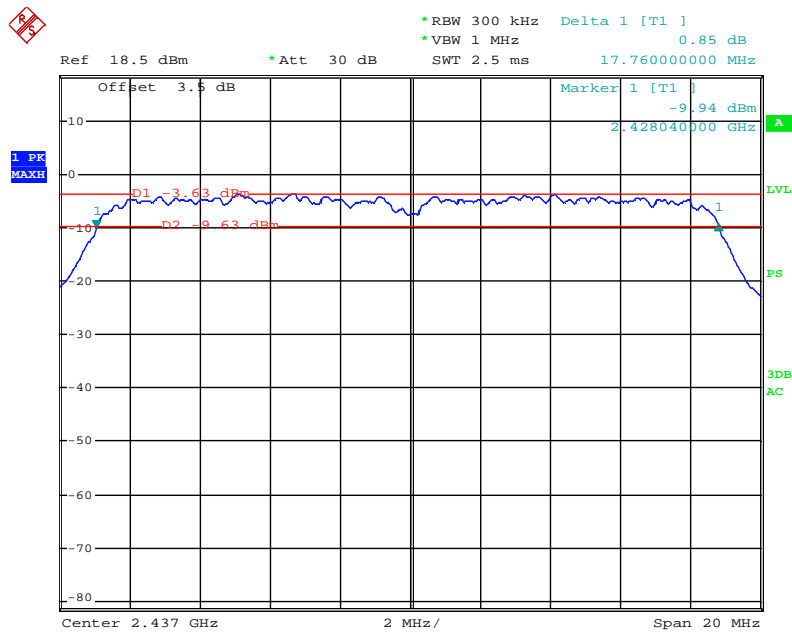

Date: 9.OCT.2012 22:56:01

### 802.11n-HT20 High Channel

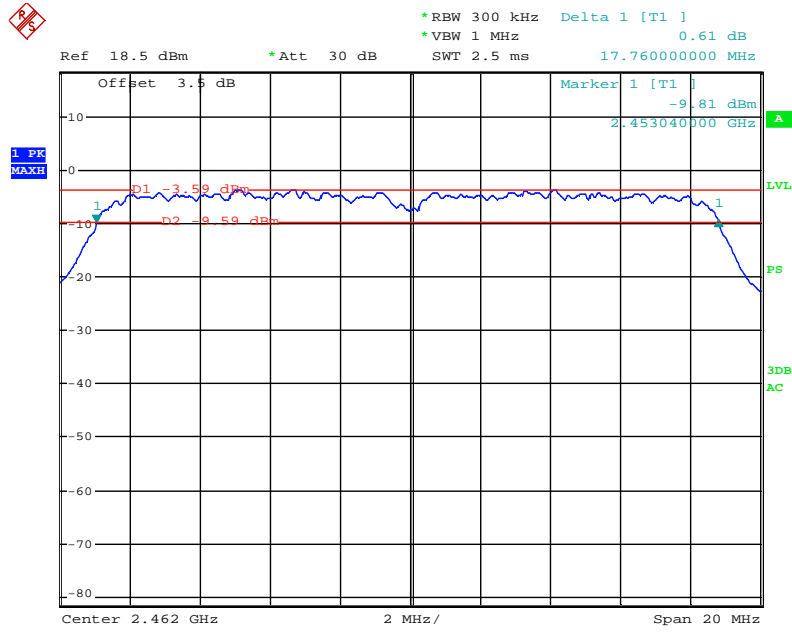

Date: 9.OCT.2012 22:57:51

## FCC §15.247(b) (3) - MAXIMUM PEAK OUTPUT POWER

### Applicable Standard

According to §15.247(b) (3), for systems using digital modulation in the 902-928 MHz, 2400-2483.5 MHz, and 5725-5850 MHz bands: 1 Watt. As an alternative to a peak power measurement, compliance with the one Watt limit can be based on a measurement of the maximum conducted output power. Maximum Conducted Output Power is defined as the total transmit power delivered to all antennas and antenna elements averaged across all symbols in the signaling alphabet when the transmitter is operating at its maximum power control level. Power must be summed across all antennas and antenna elements. The average must not include any time intervals during which the transmitter is off or is transmitting at a reduced power level. If multiple modes of operation are possible (e.g., alternative modulation methods), the maximum conducted output power is the highest total transmit power occurring in any mode.

### Test Equipment List and Details

Manufacturer	Description	Model	Serial Number	Calibration Date	Calibration Due Date
Rohde & Schwarz	EMI Test Receiver	ESCI	101122	2012-08-08	2013-08-07

\* **Statement of Traceability:** Bay Area Compliance Laboratories Corp. (Shenzhen) attests that all calibrations have been performed in accordance to NVLAP requirements, traceable to the NIST.

### Test Procedure

1. Place the EUT on a bench and set it in transmitting mode.
2. Remove the antenna from the EUT and then connect a low loss RF cable from the antenna port to an EMI Test Receiver.
3. Add a correction factor to the display.

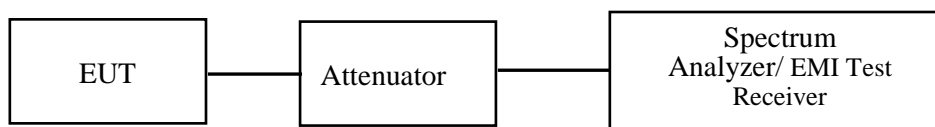

### Test Data

#### Environmental Conditions

Temperature:	23~25 ° C
Relative Humidity:	50~56 %
ATM Pressure:	100.0 kPa

*The testing was performed by Mick Yin on 2012-10-09 and 2012-10-11.*

*Test Mode: Transmitting*

Channel	Frequency (MHz)	Data Rate (Mbps)	Output Power (dBm)	Limit (dBm)	Result
<b>802.11b mode</b>					
Low	2412	1	12.13	30	Pass
Middle	2437	1	12.13	30	Pass
High	2462	1	12.22	30	Pass
<b>802.11g mode</b>					
Low	2412	6	12.00	30	Pass
Middle	2437	6	11.84	30	Pass
High	2462	6	11.88	30	Pass
<b>802.11n-HT20 mode</b>					
Low	2412	6.5	11.11	30	Pass
Middle	2437	6.5	11.36	30	Pass
High	2462	6.5	11.44	30	Pass

### 802.11b RF Output Power, Low Channel

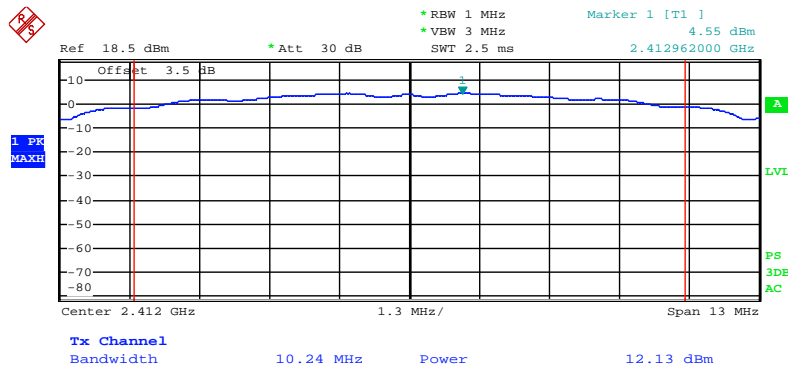

Date: 9.OCT.2012 22:15:17

### 802.11b RF Output Power, Middle Channel

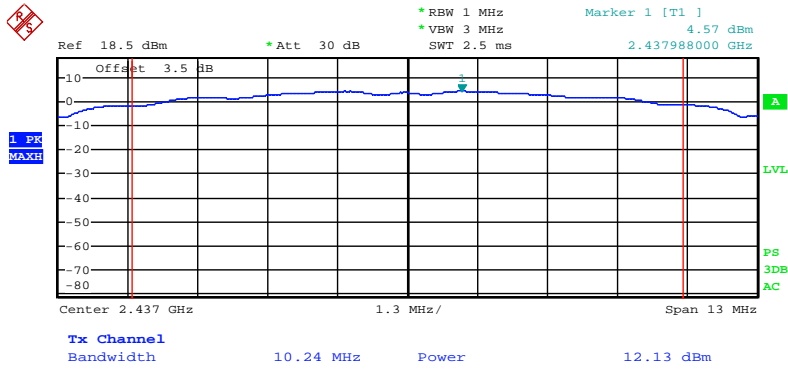

Date: 9.OCT.2012 22:14:46

### 802.11b RF Output Power, High Channel

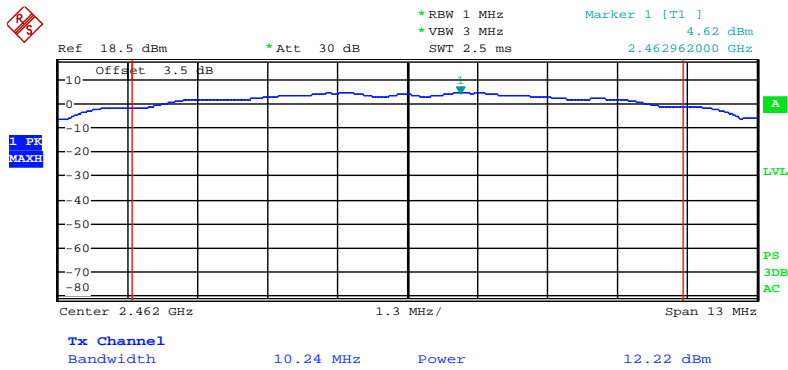

Date: 9.OCT.2012 22:14:20



### 802.11g RF Output Power, Low Channel

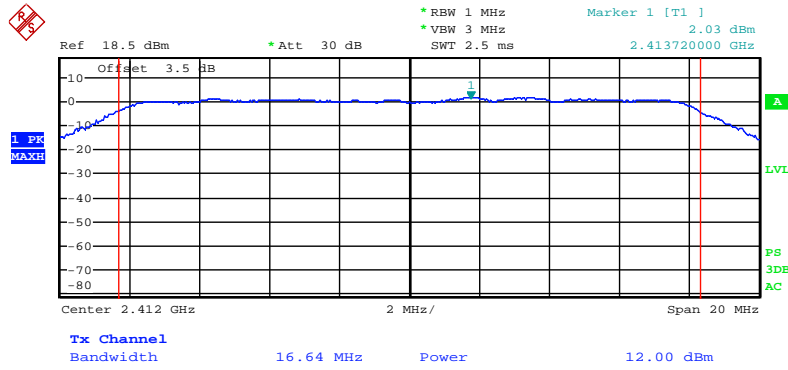

Date: 11.OCT.2012 20:13:03

### 802.11g RF Output Power, Middle Channel

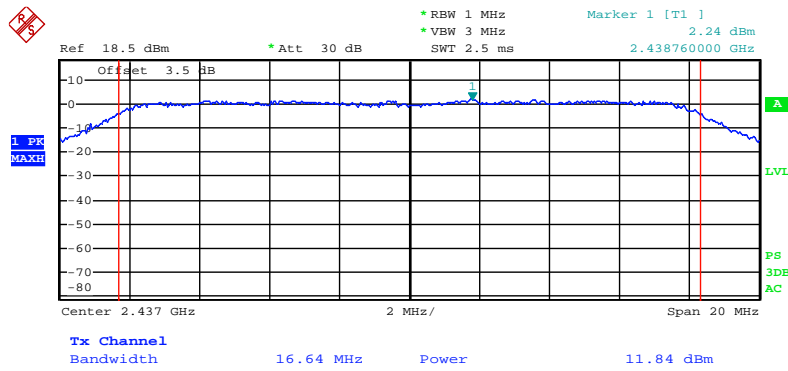

Date: 11.OCT.2012 20:14:15

### 802.11g RF Output Power, High Channel

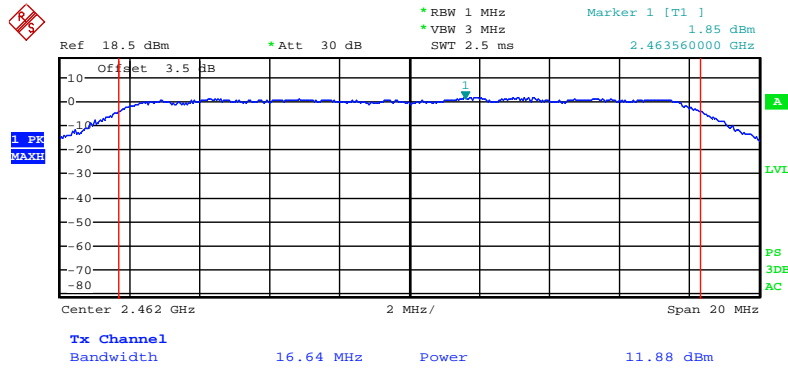

Date: 11.OCT.2012 20:14:38

### 802.11n-HT20 RF Output Power, Low Channel

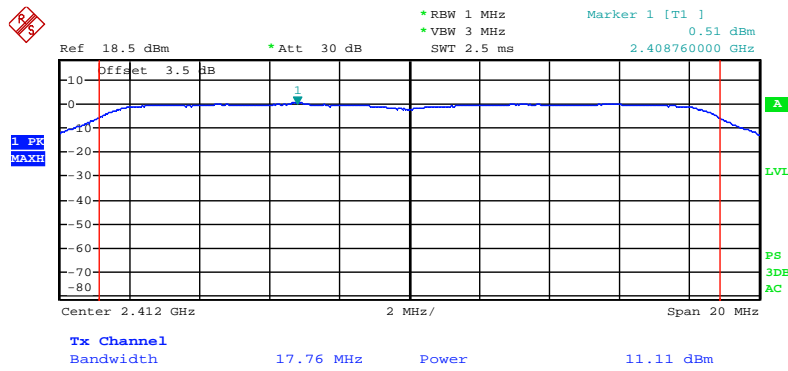

Date: 9.OCT.2012 23:02:54

### 802.11n-HT20 RF Output Power, Middle Channel

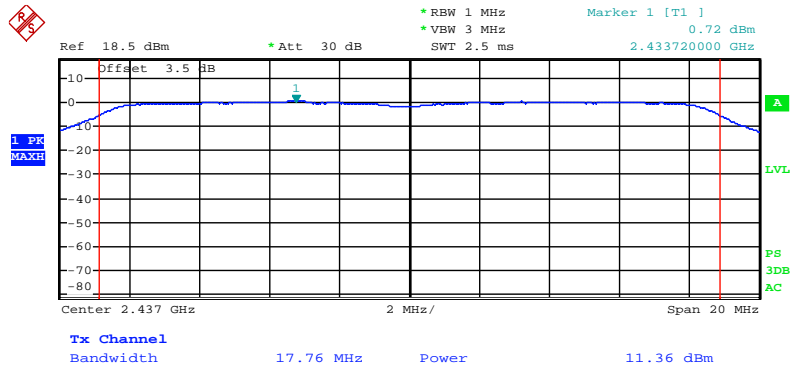

Date: 9.OCT.2012 23:03:23

### 802.11n-HT20 RF Output Power, High Channel

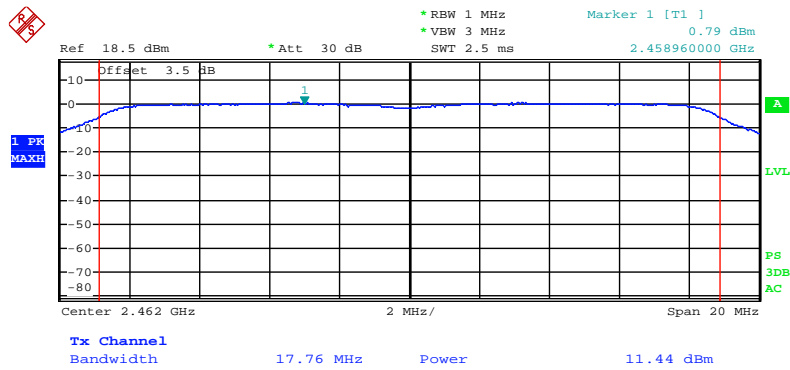

Date: 9.OCT.2012 23:02:18

## FCC §15.247(d) – 100 kHz BANDWIDTH OF FREQUENCY BAND EDGE

### Applicable Standard

In any 100 kHz bandwidth outside the frequency band in which the spread spectrum or digitally modulated intentional radiator is operating, the radio frequency power that is produced by the intentional radiator shall be at least 20 dB below that in the 100 kHz bandwidth within the band that contains the highest level of the desired power, based on either an RF conducted or a radiated measurement, provided the transmitter demonstrates compliance with the peak conducted power limits. If the transmitter complies with the conducted power limits based on the use of RMS averaging over a time interval, as permitted under paragraph (b)(3) of this section, the attenuation required under this paragraph shall be 30 dB instead of 20 dB. Attenuation below the general limits specified in §15.209(a) is not required. In addition, radiated emissions which fall in the restricted bands, as defined in §15.205(a), must also comply with the radiated emission limits specified in §15.209(a) (see §15.205(c)).

### Test Equipment List and Details

Manufacturer	Description	Model	Serial Number	Calibration Date	Calibration Due Date
Rohde & Schwarz	EMI Test Receiver	ESCI	101122	2012-08-08	2013-08-07

\* **Statement of Traceability:** Bay Area Compliance Laboratories Corp. (Shenzhen) attests that all calibrations have been performed in accordance to NVLAP requirements, traceable to the NIST.

### Test Procedure

1. Check the calibration of the measuring instrument using either an internal calibrator or a known signal from an external generator.
2. Position the EUT without connection to measurement instrument. Turn on the EUT and connect its antenna terminal to measurement instrument via a low loss cable. Then set it to any one measured frequency within its operating range, and make sure the instrument is operated in its linear range.
3. Set RBW to 100 kHz and VBW of spectrum analyzer to 300 kHz with a convenient frequency span including 100 kHz bandwidth from band edge.
4. Measure the highest amplitude appearing on spectral display and set it as a reference level. Plot the graph with marking the highest point and edge frequency.
5. Repeat above procedures until all measured frequencies were complete.

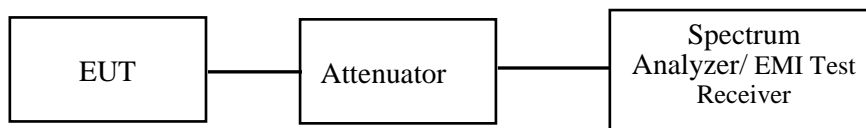

### Test Data

#### Environmental Conditions

Temperature:	25 °C
Relative Humidity:	56 %
ATM Pressure:	100.0 kPa

*The testing was performed by Mick Yin on 2012-10-09.*

*Test Mode: Transmitting*

**Test Result:** *Compliance.*

Band edge	Delta Peak to band emission (dBc)	Delta Limit (dBc)	Result
<b>802.11b mode</b>			
Left side	37.72	20	Pass
Right side	48.49	20	Pass
<b>802.11g mode</b>			
Left side	32.21	20	Pass
Right side	41.08	20	Pass
<b>802.11n-HT20 mode</b>			
Left side	29.48	20	Pass
Right side	39.42	20	Pass

Please refer to following plots.

### 802.11b Band Edge, Left Side

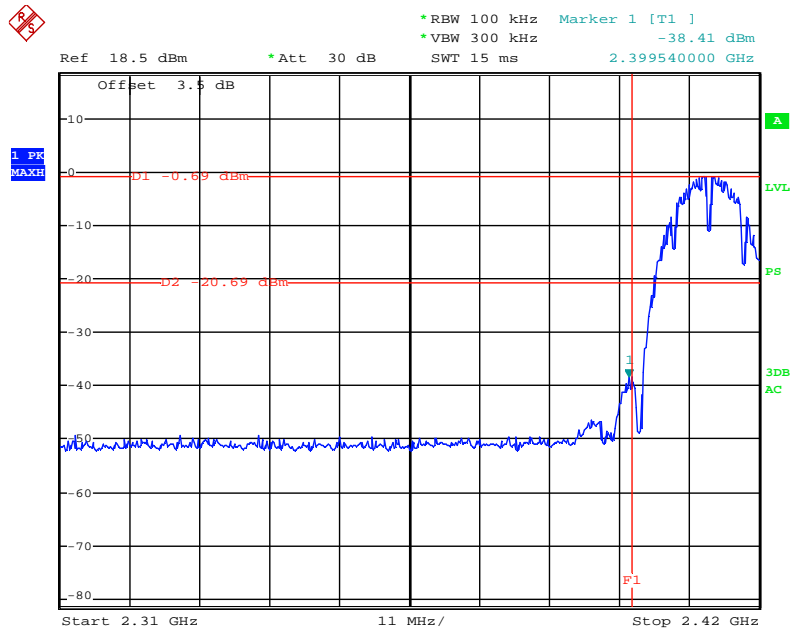

Date: 9.OCT.2012 22:22:23

### 802.11b Band Edge, Right Side

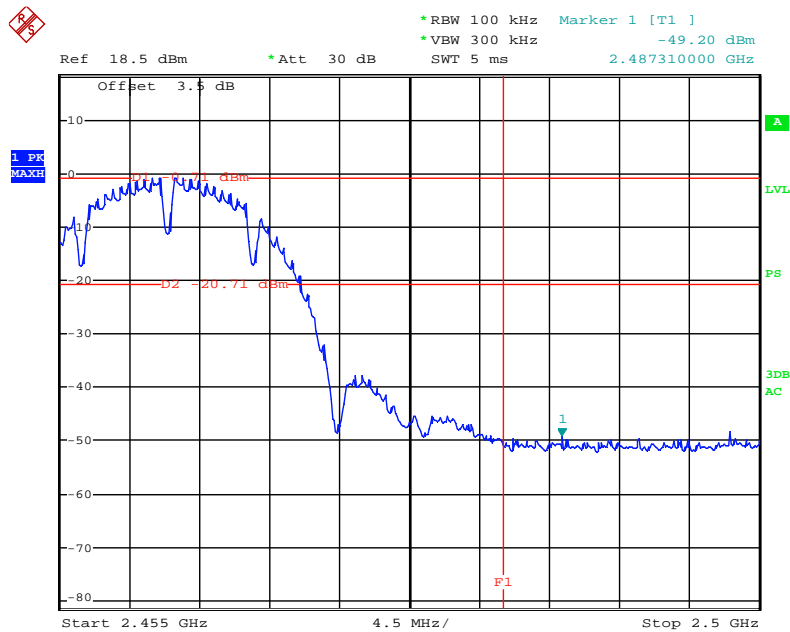

Date: 9.OCT.2012 22:20:53

### 802.11g Band Edge, Left Side

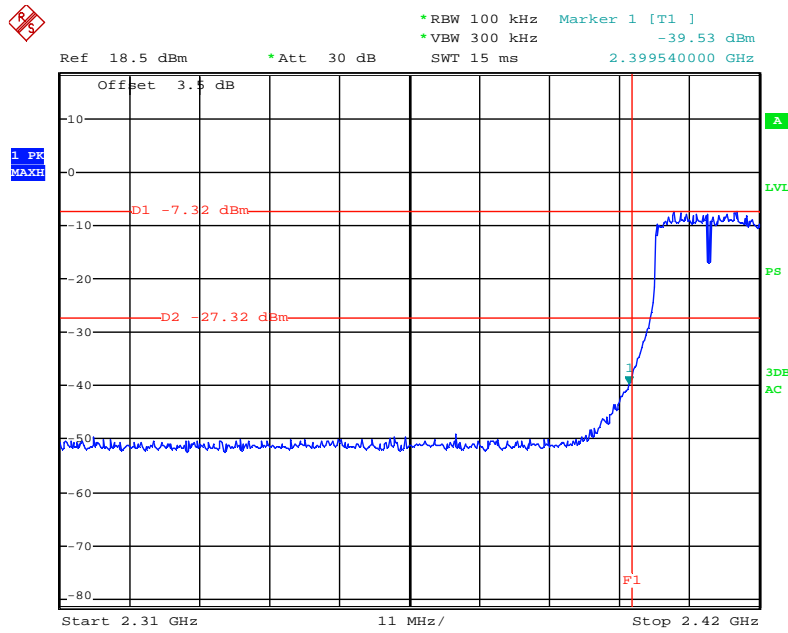

Date: 9.OCT.2012 22:50:58

### 802.11g Band Edge, Right Side

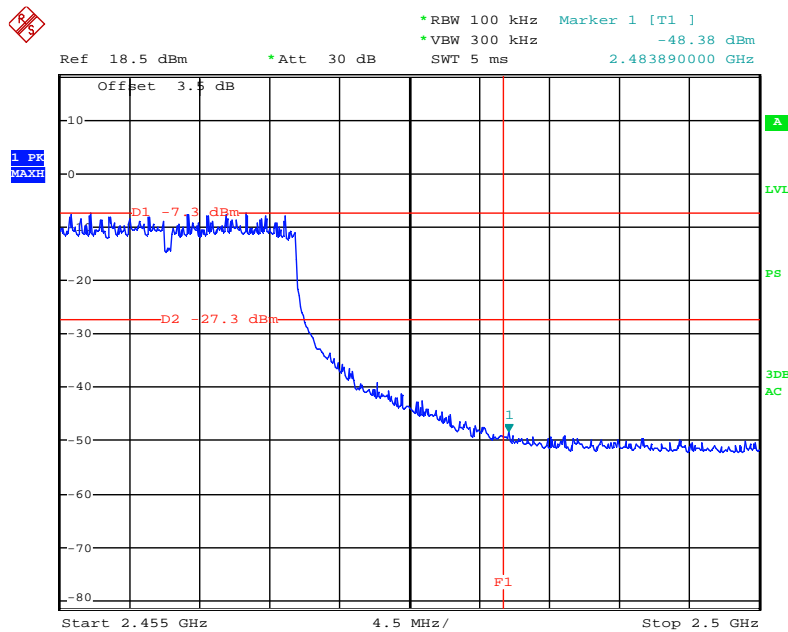

Date: 11.OCT.2012 20:08:14

### 802.11n-HT20 Band Edge, Left Side

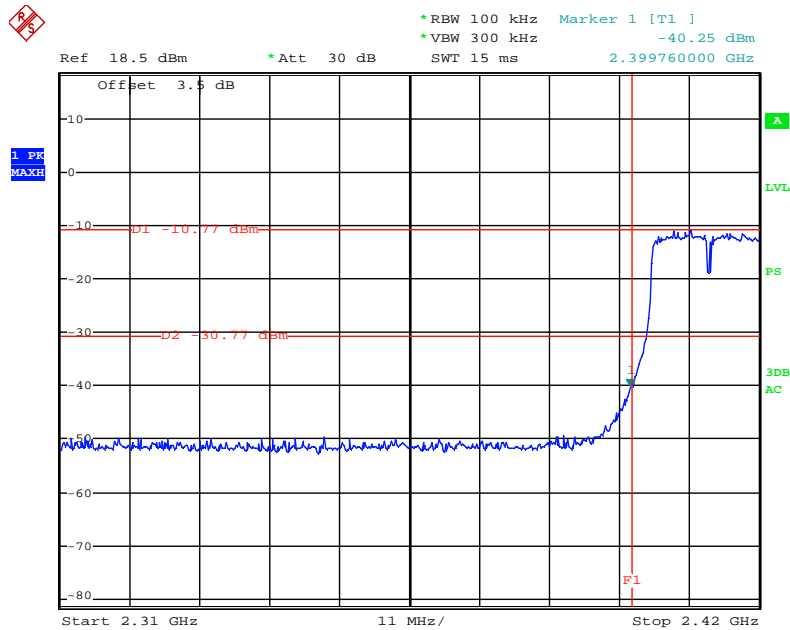

Date: 9.OCT.2012 23:07:08

### 802.11n-HT20 Band Edge, Right Side

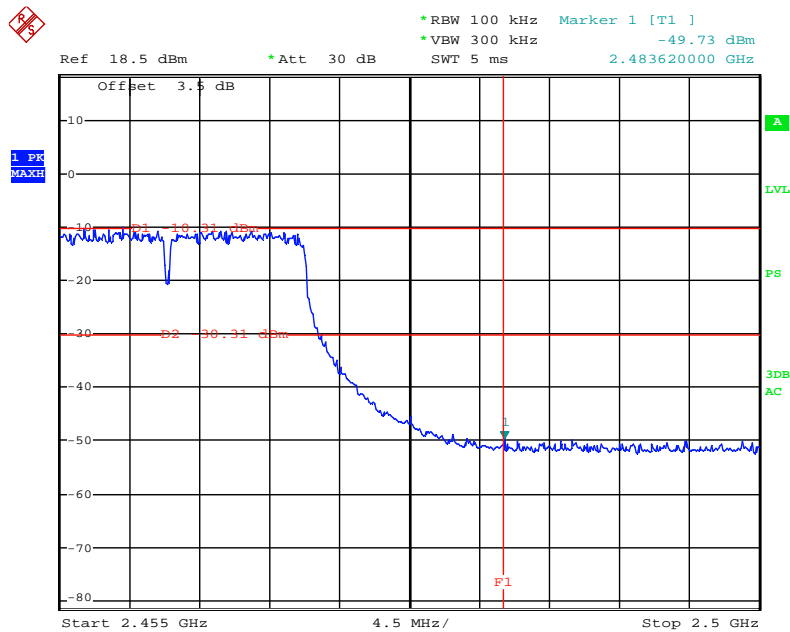

Date: 9.OCT.2012 23:05:58



## FCC §15.247(e) - POWER SPECTRAL DENSITY

### Applicable Standard

For digitally modulated systems, the power spectral density conducted from the intentional radiator to the antenna shall not be greater than 8 dBm in any 3 kHz band during any time interval of continuous transmission. This power spectral density shall be determined in accordance with the provisions of paragraph (b) of this section. The same method of determining the conducted output power shall be used to determine the power spectral density.

### Test Equipment List and Details

Manufacturer	Description	Model	Serial Number	Calibration Date	Calibration Due Date
Rohde & Schwarz	EMI Test Receiver	ESCI	101122	2012-08-08	2013-08-07

\* **Statement of Traceability:** Bay Area Compliance Lab Corp. (Shenzhen) attests that all calibrations have been performed in accordance to NVLAP requirements, traceable to the NIST.

### Test Procedure

1. Use this procedure when the maximum peak conducted output power in the fundamental emission is used to demonstrate compliance.
2. Set the RBW = 100 kHz.
3. Set the VBW  $\geq$  300 kHz.
4. Set the span to 5-30 % greater than the EBW.
5. Detector = peak.
6. Sweep time = auto couple.
7. Trace mode = max hold.
8. Allow trace to fully stabilize.
9. Use the peak marker function to determine the maximum power level in any 100 kHz band segment within the fundamental EBW.
10. Scale the observed power level to an equivalent value in 3 kHz by adjusting (reducing) the measured power by a bandwidth correction factor (BWCF) where  $BWCF = 10\log(3\text{ kHz}/100\text{ kHz} = -15.2\text{ dB})$ .
11. The resulting peak PSD level must be  $\leq$  8 dBm.

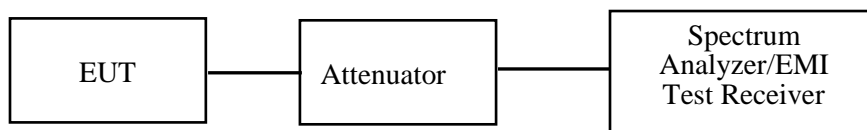

### Test Data

#### Environmental Conditions

Temperature:	25 °C
Relative Humidity:	56 %
ATM Pressure:	100.0 kPa

*The testing was performed by Mick Yin on 2012-10-09.*

Test Mode: Transmitting

Test Result: Pass

Channel	Frequency (MHz)	Data Rate (Mbps)	Power spectral density (dBm/100kHz)	BWCF (dB)	Power spectral density (dBm/3kHz)	Limit (dBm/3kHz)
<b>802.11b mode</b>						
Low	2412	1	-0.68	-15.2	-15.88	8
Middle	2437	1	-0.62	-15.2	-15.72	8
High	2462	1	-0.65	-15.2	-15.85	8
<b>802.11g mode</b>						
Low	2412	6	-7.47	-15.2	-22.67	8
Middle	2437	6	-7.27	-15.2	-22.47	8
High	2462	6	-7.34	-15.2	-22.54	8
<b>802.11n-HT20 mode</b>						
Low	2412	6.5	-10.53	-15.2	-25.73	8
Middle	2437	6.5	-10.28	-15.2	-25.48	8
High	2462	6.5	-10.14	-15.2	-25.34	8

**Power Spectral Density, 802.11b Low Channel**

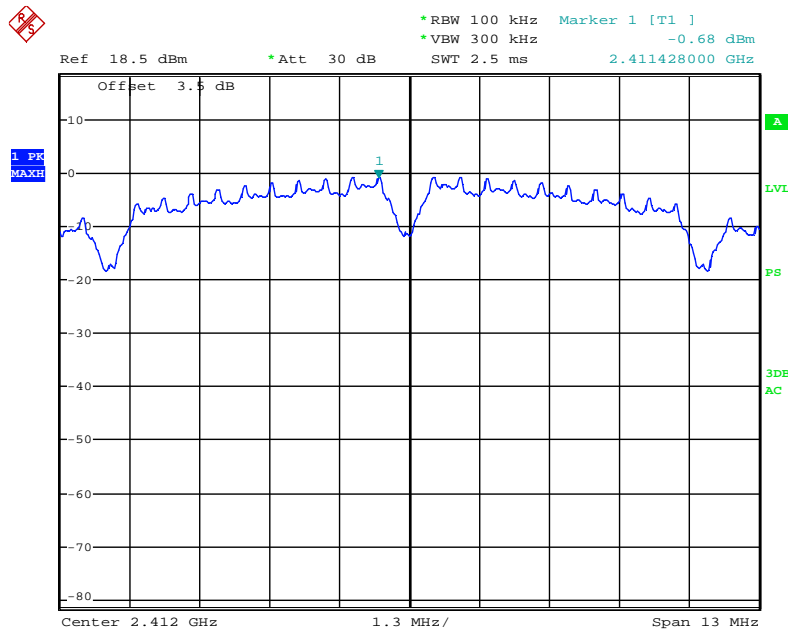

Date: 9.OCT.2012 22:16:30

### Power Spectral Density, 802.11b Middle Channel

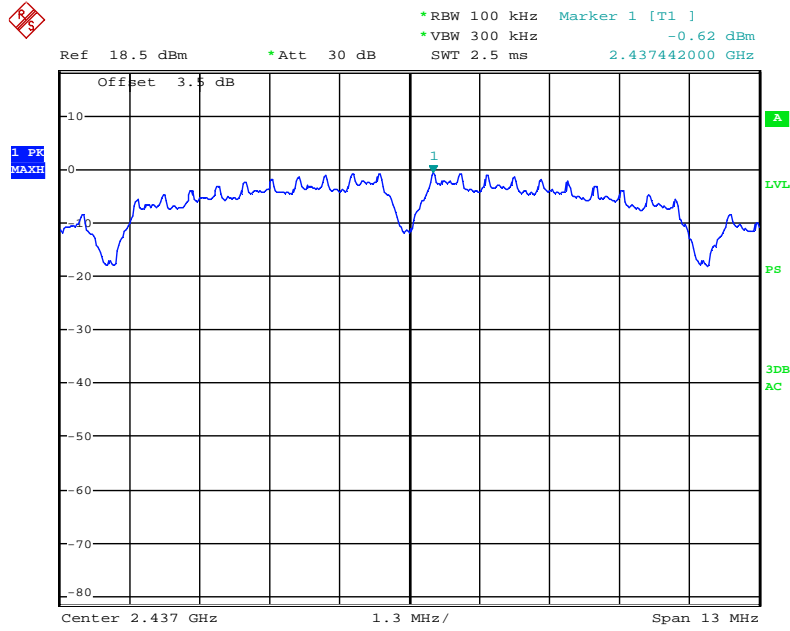

Date: 9.OCT.2012 22:17:52

### Power Spectral Density, 802.11b High Channel

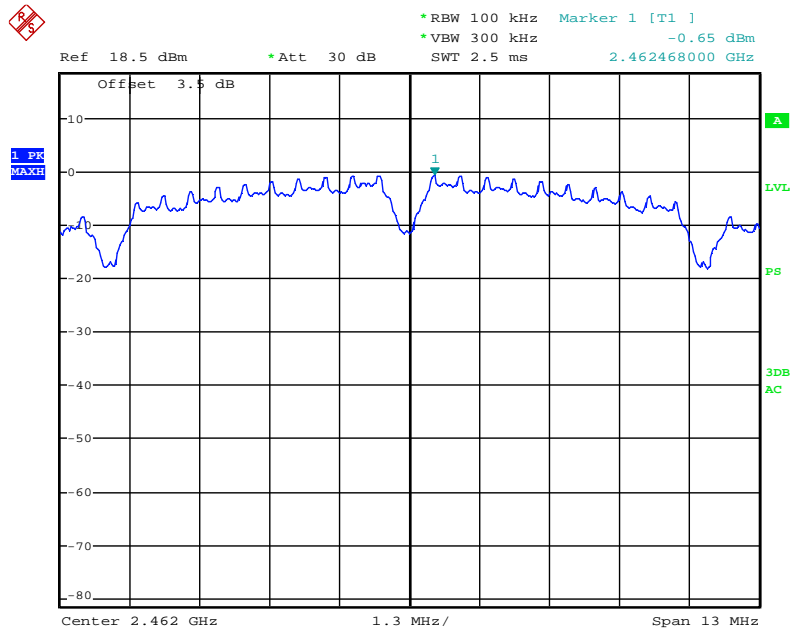

Date: 9.OCT.2012 22:18:57

### Power Spectral Density, 802.11g Low Channel

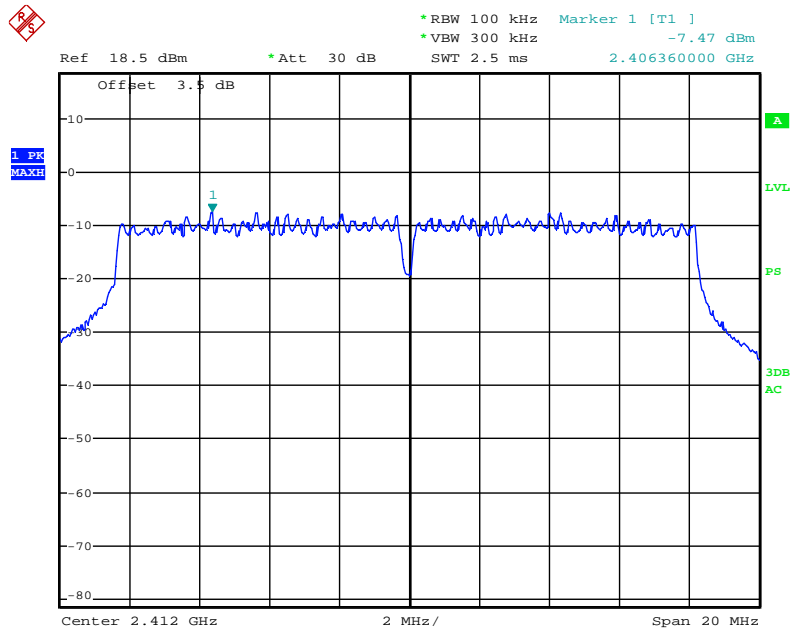

Date: 9.OCT.2012 22:49:14

### Power Spectral Density, 802.11g Middle Channel

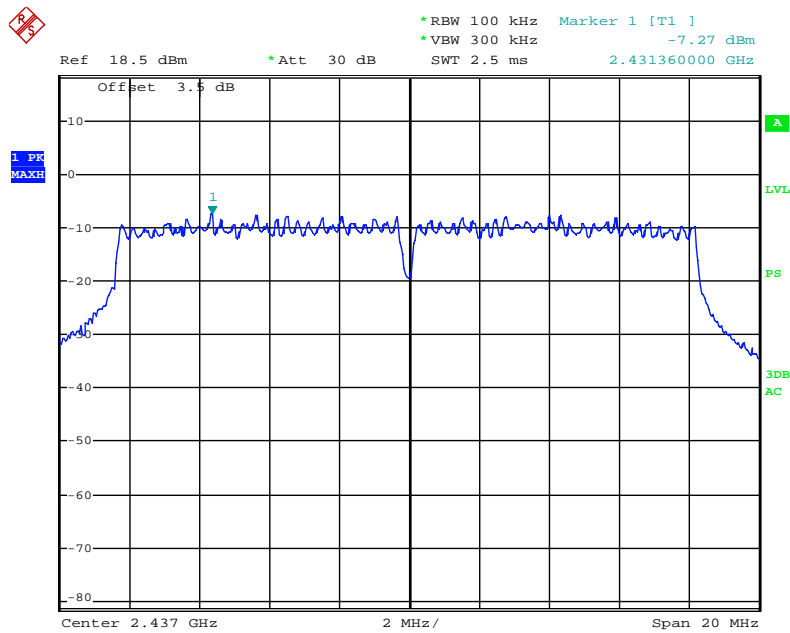

Date: 9.OCT.2012 22:48:19

### Power Spectral Density, 802.11g High Channel

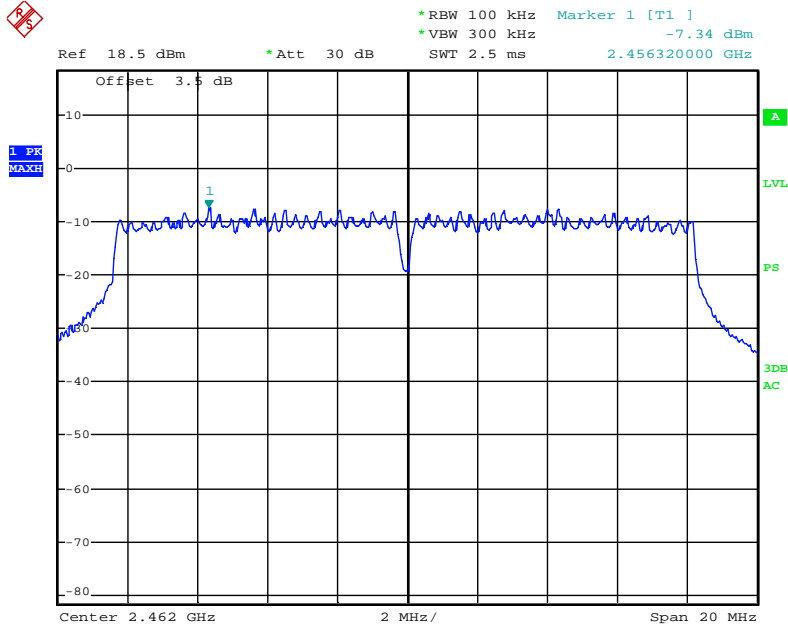

Date: 9.OCT.2012 22:48:45

### Power Spectral Density, 802.11n-HT20 Low Channel

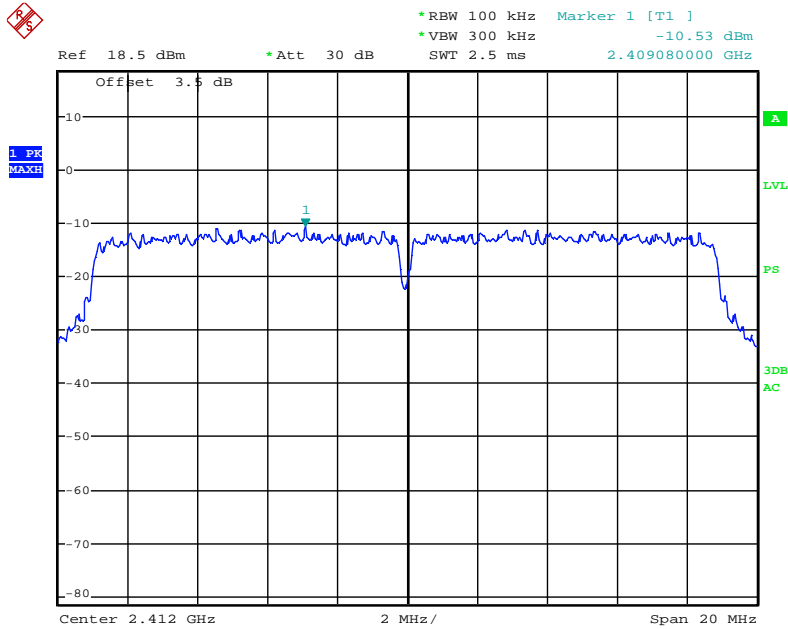

Date: 9.OCT.2012 23:04:28

### Power Spectral Density, 802.11n-HT20 Middle Channel

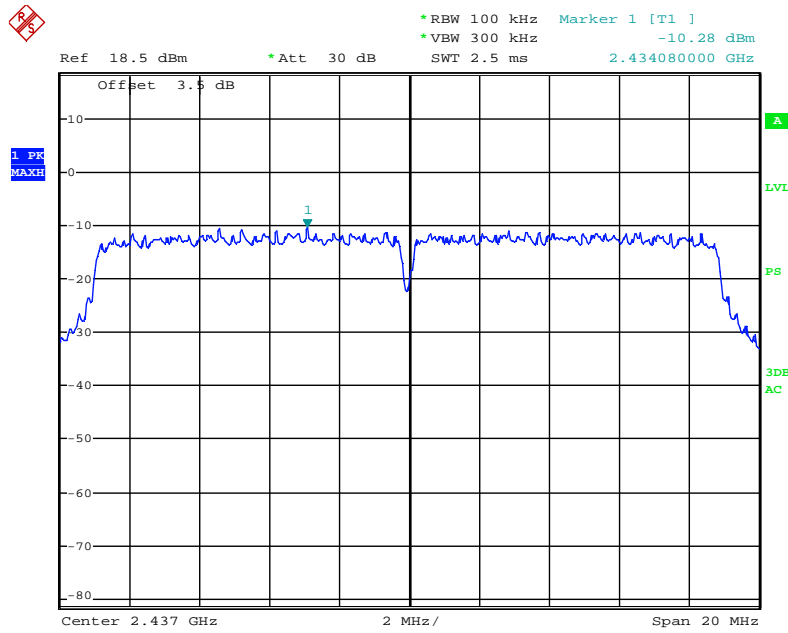

Date: 9.OCT.2012 23:03:55

### Power Spectral Density, 802.11n-HT20 High Channel

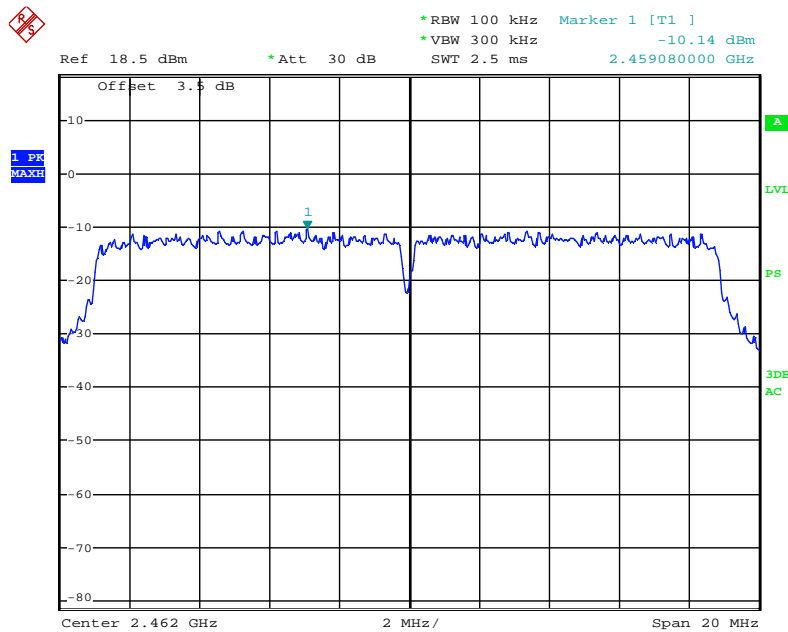

Date: 9.OCT.2012 23:04:49

\*\*\*\*\* END OF REPORT \*\*\*\*\*