

**COMPLIANCE WORLDWIDE INC.
TEST REPORT 276-19**

In Accordance with the Requirements of
FCC PART 15.247, SUBPART C
Innovation, Science and Economic Development Canada
RSS-247, Issue 2

Low Power License-Exempt Radio Communication Devices
Intentional Radiators

Issued to
iRobot Corporation
8 Crosby Drive
Bedford, MA 01730
781-430-3284

for the
Terra Remote
Model # AXA-Y1, Part # 4515706
2.4 GHz Bluetooth Low Energy Radio

FCC ID: UFEAXA-Y1

Report Issued on July 12, 2019

Tested by

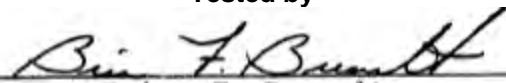

Brian F. Breault

Reviewed by



Larry K. Stillings

Table of Contents

1. Scope.....	3
2. Product Details.....	3
2.1 Manufacturer	3
2.2 Model Number	3
2.3 Serial Number.....	3
2.4 Description.....	3
2.5 Power Source	3
2.6 Hardware Revision	3
2.7 Software Revision.....	3
2.8 Modulation Type.....	3
2.9 Operating Frequency.....	3
2.10 EMC Modifications.....	3
3. Product Configuration	3
3.1 Operational Characteristics & Software.....	4
3.2 EUT Hardware.....	4
3.3 EUT Cables/Transducers	4
3.4 Support Equipment.....	4
3.5 Block Diagram	5
4. Measurements Parameters.....	5
4.1 Measurement Equipment Used to Perform Test.....	5
4.2 Measurement Software.....	6
4.3 Measurement & Equipment Setup.....	7
4.4 Measurement Procedures	7
4.5 Measurement Uncertainty.....	7
5. Choice of Equipment for Test Suits.....	7
5.1 Choice of Model.....	7
5.2 Presentation	7
5.3 Choice of Operating Frequencies	7
5.4 Mode of Operation	8
6. Measurement Summary.....	8
7. Measurement Data	9
7.1 Antenna Requirement.....	9
7.2 Minimum DTS Bandwidth	10
7.3 Maximum Peak Conducted Output Power.....	12
7.4 Operation with directional antenna gains greater than 6 dBi	14
7.5 Transmitter Spurious Radiated Emissions.....	15
7.6 Band Edge and Out of Band Measurements	17
7.7 Emissions in Non-restricted Frequency Bands	21
7.8 Peak Power Spectral Density	22
7.9 Duty Cycle	25
7.11 99% (Occupied) Bandwidth	27
7.12 Public Exposure to Radio Frequency Energy Levels.....	29
8. Test Site Description.....	37
Appendix A - Transmitter Spurious Radiated Emissions Test Data	38

1. Scope

This test report certifies that the the iRobot Corporation Terra Remote, model AXA-Y1, 2.4 GHz Bluetooth Low Energy radio, as tested, meets the FCC Part 15, Subpart requirements. The scope of this test report is limited to the test sample provided by the client, only in as much as that sample represents other production units. If any significant changes are made to the unit, the changes shall be evaluated and a retest may be required.

2. Product Details

- 2.1. Manufacturer:** iRobot
2.2. Model Number: AXA-Y1
2.3. Serial Number: P5C-2
2.4. Description: The robot's remote control communicates with the robot using Bluetooth Low Energy (BLE). This remote control is used during installation to train the robot to the user's yard shape. The remote control can also be used anytime by the user to drive the robot manually (not while mowing) when the robot is in "remote" mode
2.5. Power Source: DC 3.0 Volts (2 X AA batteries)
2.6. Hardware Revision: Rev F
2.7. Firmware Version: Remote Control Firmware BLE v1.12
2.8. Modulation Type: GFSK
2.9. Operating Frequency: 2.402 to 2.480 GHz Nominal
2.10. EMC Modifications: None

3. Product Configuration

3.1. Operational Characteristics & Software

For the transmitter measurement testing of the iRobot Terra Remote, the onboard processor firmware was modified to accept test commands for frequency, modulation, etc. The commands were executed via a terminal emulator. Connection to the device was accomplished using a USB to FTDI cable from the PC. Testing was performed at the default power setting of 0 dBm.

The commands in the following table were used during the transmitter measurements in this test report. For each test, the worst case setting for amplitude and bandwidth was determined at the time the test was performed.

TM 00	Disable transmission		
TM 01	2402 MHz, unmodulated	TM 05	2402 MHz, modulated
TM 02	2426 MHz, unmodulated	TM 06	2426 MHz, modulated
TM 03	2440 MHz, unmodulated	TM 07	2440 MHz, modulated
TM 04	2480 MHz, unmodulated	TM 08	2480 MHz, modulated

3. Product Configuration (continued)

3.1. Operational Characteristics & Software (continued)

During all radiated emissions measurement testing, the product was mounted on a polystyrene form to facilitate rotating the device through three orthogonal axes, as required by ANSI C63.10, section 5.10.1, for a hand held or body worn device. The three axes were defined as follows:

- | | | |
|--------|--|--|
| X Axis | Device on left side. | Joystick side (front) faces the antenna at 0°. |
| Y Axis | Device is vertical with joystick at the top. | Joystick side (front) faces the antenna at 0°. |
| Z Axis | Joystick side (front) faces up. | Side furthest from joystick faces antenna at 0°. |



X-Axis



Y-Axis



Z-Axis

3.2. EUT Hardware

Manufacturer	Model	Serial Number	Input Volts	Frq (Hz) Or DC	Description/Function
iRobot	AXA-Y1	P5C-2	3.0	DC	Robotic lawnmower remote control

3.3. Support Equipment

Device	Manufacturer	Model	Serial No.	Comment
Laptop Computer	Dell	Vostro E1505	5573349937	BLE Radio Configuration

3.4. Cables

Cable Type	Length	Shield	From	To
USB - FTDI	1 Meter	Yes	EUT	Laptop for Configuration

3. Product Configuration

3.5. Block Diagram

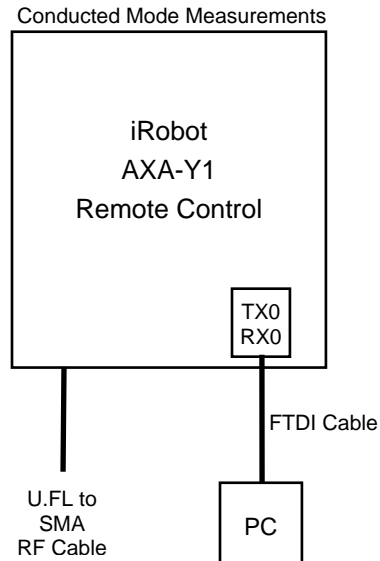

For radiated mode measurements, the U.FL to SMA RF cable was omitted and the production antenna was installed as designed.

Power to the device under test was provided by two AA batteries.

4. Measurements Parameters

4.1. Measurement Equipment Used to Perform Test

Device	Manufacturer	Model No.	Serial No.	Cal Due	Interval
EMI Test Receiver, 9kHz - 7GHz ¹	Rohde & Schwarz	ESR7	101156	9/10/2020	2 Years
EMI Test Receiver, 10 Hz - 7GHz ¹	Rohde & Schwarz	ESR7	101770	10/3/2020	2 Years
Spectrum Analyzer, 2 Hz to 26.5 GHz ²	Rohde & Schwarz	FSW26	102057	9/13/2020	2 Years
Spectrum Analyzer, 9 kHz to 40 GHz ³	Rohde & Schwarz	FSV40	100899	9/10/2020	2 Years
EMI Receiver 9 kHz - 1 GHz	Hewlett Packard	8546A	3650A00360	9/11/2020	2 Years
Loop Antenna 9 kHz - 30 MHz	EMCO	6512	9309-1139	1/28/2022	3 Years
Biconilog Antenna, 30 MHz - 2 GHz	Sunol Sciences	JB1	A050913	6/5/2021	2 Years
Horn Antenna, 960 MHz to 18 GHz	Electro-Metrics	EM-6961	6337	10/3/2020	2 Years
Horn Antenna, 18 GHz to 40 GHz	Com-Power	AH-840	101032	9/28/2020	2 Years
Preamplifier, 1 GHz to 26.5 GHz	Hewlett Packard	8449B	3008A01323	9/11/2020	2 Years
Preamplifier 18 to 40 GHz	Miteq	JSD42-21004200-40-5P	649199/649219	10/31/2019	1 Year
Digital Barometer	Control Company	4195	ID236	4/3/2020	2 Years
Temperature Chamber	Associated Environmental	SD-308	10782	CNR	

¹ ESR7 Firmware revision: V3.46 SP1, Date installed: 12/22/2018 Previous V3.36 SP2, installed 12/5/2018.
² FSW26 Firmware revision: V4.30 SP1, Date installed: 02/22/2019 Previous V3.36 SP2, installed 10/26/2018.
³ FSV40 Firmware revision: V2.30 SP4, Date installed: 05/04/2016 Previous V2.30 SP1, installed 10/22/2014.

4. Measurements Parameters (continued)

4.2. Measurement Software

Manufacturer	Software Description	Title or Model #	Rev.	Report Sections
Compliance Worldwide	Test Report Generation Software	Test Report Generator	1.0	Not used for this test

4.2. Measurement & Equipment Setup

Test Dates:	6/26/2019, 7/12/2019
Test Engineers:	Brian Breault
Normal Site Temperature (15 - 35°C):	21.2
Relative Humidity (20 -75%RH):	35
Frequency Range:	32 kHz to 25 GHz
Measurement Distance:	3 Meters
EMI Receiver IF Bandwidth:	120 kHz - 30 MHz to 1 GHz 1 MHz - Above 1 GHz
EMI Receiver Average Bandwidth:	300 kHz - 30 MHz to 1 GHz 3 MHz - Above 1 GHz
Detector Function:	Peak, Quasi-Peak & Average

4.3. Measurement Procedure

Test measurements were made in accordance FCC Part 15.247, Operation within the bands 902–928 MHz, 2400–2483.5 MHz, and 5725–5850 MHz.

The test methods used to generate the data in this test report are in accordance with ANSI C63.10: 2013, American National Standard for Testing Unlicensed Wireless Devices.

4.4. Choice of Operating Frequencies

Low Channel	37	2402 MHz
Middle Channel	17	2440 MHz
High Channel	39	2480 MHz

4.5. Measurement Uncertainty

The following uncertainties are expressed for an expansion/coverage factor of K=2.

RF Frequency	$\pm 1 \times 10^{-8}$
Radiated Emission of Transmitter	± 4.55 dB
Radiated Emission of Receiver	± 4.55 dB
Temperature	$\pm 0.91^{\circ}$ C
Humidity	$\pm 5\%$

5. Choice of Equipment for Test Suits

5.1 Choice of Model

This test report is based on the one test sample supplied by the manufacturer. These units are reported by the manufacturer to be equivalent to the production units.

5.2 Presentation

The test samples were tested complete with all required ancillary equipment. Refer to Section 3 of this report for product equipment configuration.

5.3 Choice of Operating Frequencies

The iRobot Terra Remote 2.4 GHz Bluetooth Low Energy Radio, as tested, operates on 40 channels, from channels 0 to 39 in the 2.4 GHz band.

In accordance with ANSI C63.10-2013, section 5.6, and FCC Part 15.31 (m), the choice of operating frequencies selected for the testing detailed in this report are as follows:

Channel	Frequency (MHz)	Channel	Frequency (MHz)	Channel	Frequency (MHz)	Channel	Frequency (MHz)
37	2402	9	2422	18	2442	28	2462
0	2404	10	2424	19	2444	29	2464
1	2406	38	2426	20	2446	30	2466
2	2408	11	2428	21	2448	31	2468
3	2410	12	2430	22	2450	32	2470
4	2412	13	2432	23	2452	33	2472
5	2414	14	2434	24	2454	34	2474
6	2416	15	2436	25	2456	35	2476
7	2418	16	2438	26	2458	36	2478
8	2420	17	2440	27	2460	39	2480

5. Choice of Equipment for Test Suits (continued)

5.4 Mode of Operation

Modulation type : GFSK
 Payload pattern : PRB29
 Payload Length : 37 bytes

For band edge measurements (section 7.6), the DTS bandwidth measurements were taken into consideration for the worst case examples.

6. Measurement Summary

Test Requirement	FCC Rule Requirement	ISED Rule Requirement	Test Report Section	Result
Antenna Requirement	15.203	---	7.1	Compliant
Minimum DTS Bandwidth	15.247 (a) (2)	RSS-247 5.2 a)	7.2	Compliant
Maximum Peak Conducted Output Power	15.247 (b) (1)	RSS-247 5.4 d)	7.3	Compliant
Operation with directional antenna gains greater than 6 dBi	15.247 (b) (4)	---	7.4	Compliant
Spurious Radiated Emissions	15.247 (d)	RSS-GEN 6.13	7.5	Compliant
Spurious Radiated Emissions (> GHz) - Harmonic Measurements	15.247 (d)	RSS-GEN 6.13		Compliant
Lower and Upper Band Edges	15.247 (d)	RSS-GEN 6.13	7.6	Compliant
Emissions in Non-restricted Frequency Bands	15.247(e)	RSS-GEN 6.13	7.7	Compliant
Peak Power Spectral Density	15.247(e)	RSS-247 5.2 b)	7.8	Compliant
AC Power Line Conducted Emissions	15.207	RSS-GEN 7.2	--	Battery operated device
Duty Cycle	15.207	N/A	7.9	Compliant
99% (Occupied) Bandwidth	1.1307 (b) (1)	RSS-GEN 6.7	7.10	Compliant
Public Exposure to Radio Frequency Energy Levels	1.1307 (b) (1)	RSS-GEN, Issue 5, Section 3.4, RSS 102	7.11	Compliant

7. Measurement Data

7.1. Antenna Requirement (15.203)

Requirement: An intentional radiator shall be designed to ensure that no antenna other than that furnished by the responsible party shall be used with the device. The use of a permanently attached antenna or of an antenna that uses a unique coupling to the intentional radiator shall be considered sufficient to comply with the provisions of this Section.

Results: The the iRobot Terra Remote utilizes a an etch antenna which is not user replaceable.

7. Measurement Data

7.2. Minimum DTS Bandwidth (15.247 (a) (2), ISED_RSS-247 5.2 a))

Requirement: 15.247 (a) (2)

Systems using digital modulation techniques may operate in the 902 - 928 MHz, 2400 - 2483.5 MHz, and 5725 - 5850 MHz bands. The minimum 6 dB bandwidth shall be at least 500 kHz.

Procedure: This test was performed in accordance with the procedure detailed in FCC OET publication number 558074, Section 8.1 Option 1, DTS (6 dB) Channel Bandwidth.

Results: The device under test meets the minimum 500 kHz DTS (6 dB) bandwidth requirement.

Channel	Frequency (MHz)	-6 dB Bandwidth (kHz)	Minimum -6 dB Bandwidth (kHz)	Result
37	2402	674.27	>500	Compliant
17	2440	693.06	>500	Compliant
39	2480	706.66	>500	Compliant

7.2.1. Low Channel – 37, 2402 MHz

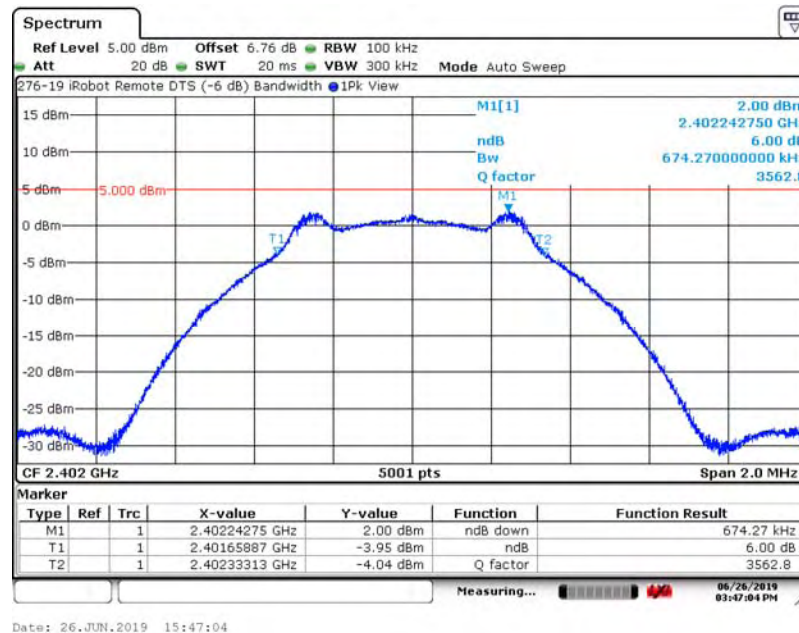

7. Measurement Data

7.2. Minimum DTS Bandwidth (15.247 (a) (2)) (continued)

7.2.2. Middle Channel – 38, 2426 MHz

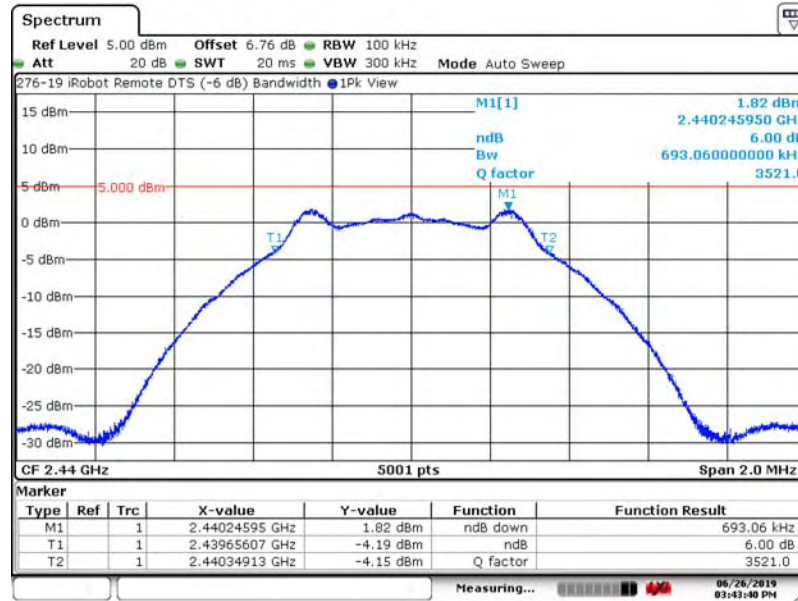

Date: 26 JUN.2019 15:43:40

7.2.3. High Channel – 39, 2480 MHz

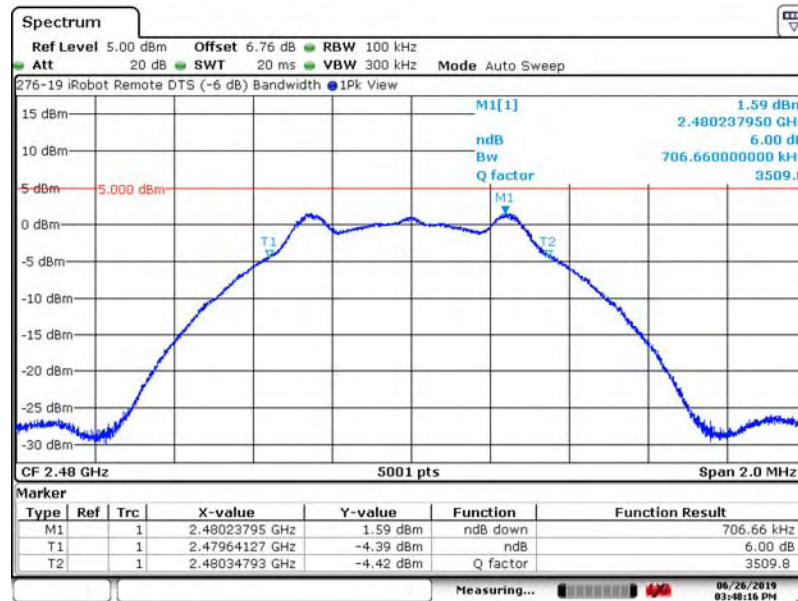

Date: 26 JUN.2019 15:48:16

7. Measurement Data (continued)

7.3. Maximum Peak Conducted Output Power (FCC 15.247 (b)(3), ISED RSS-247 5.4 d)

Requirement: (15.247 (b) (3))

The maximum peak conducted output power of the intentional radiator shall not exceed the following: For systems using digital modulation in the 902–928 MHz, 2400–2483.5 MHz, and 5725–5850 MHz bands: 1 Watt (+30 dBm).

Procedure: This test was performed in accordance with the procedure detailed in FCC OET publication number KDB 558074, Section 9.1.1.

Test Note: A spectrum analyzer resolution bandwidth of 1 MHz and a video bandwidth of 3 MHz were used to meet the requirements of FCC OET publication number 558074, Section 9.1.1 and the measured product DTS bandwidth.

Results: The device under test meets the required maximum peak conducted output power level of 1 Watt (125.2 dB μ V/m at 3 Meters).

Channel	Frequency	Maximum Peak Radiated Output Power	Peak Limit	Margin	Result
	(MHz)	(m)	(dBm)	(dB)	
37	2402	2.21	30	-27.79	Compliant
17	2440	2.07	30	-27.93	Compliant
39	2480	1.87	30	-28.13	Compliant

7.3.1. Low Channel – 37, 2402 MHz

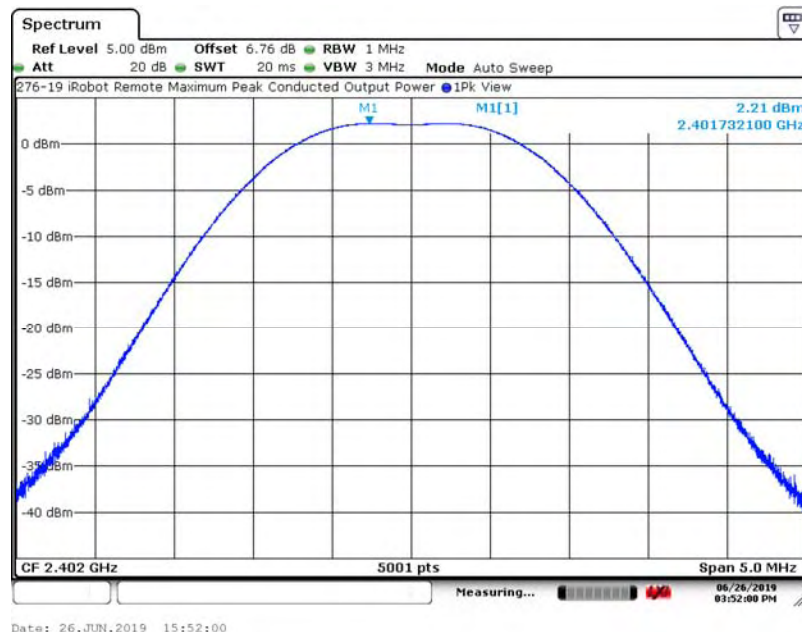

7. Measurement Data

7.3. Maximum Peak Conducted Output Power (continued)

7.3.2. Middle Channel – 38, 2426 MHz

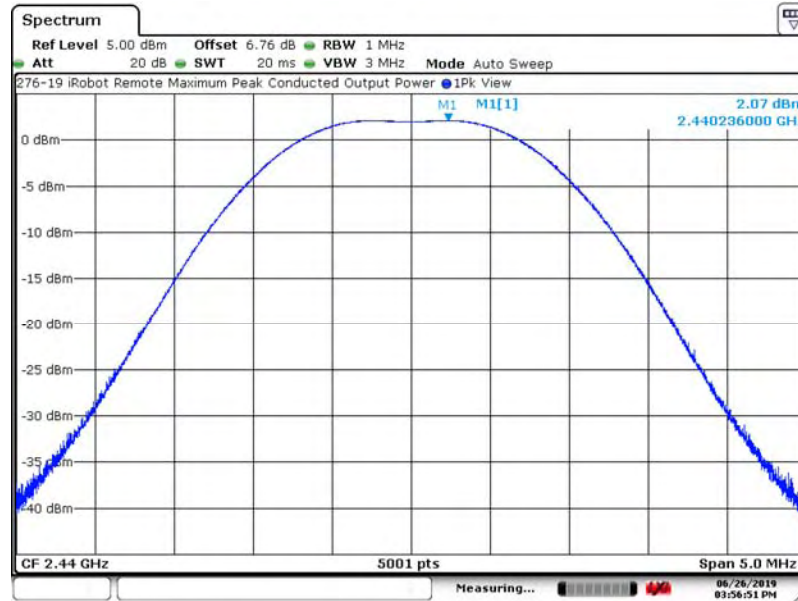

Date: 26.JUN.2019 15:56:51

7.3.3. High Channel – 39, 2480 MHz

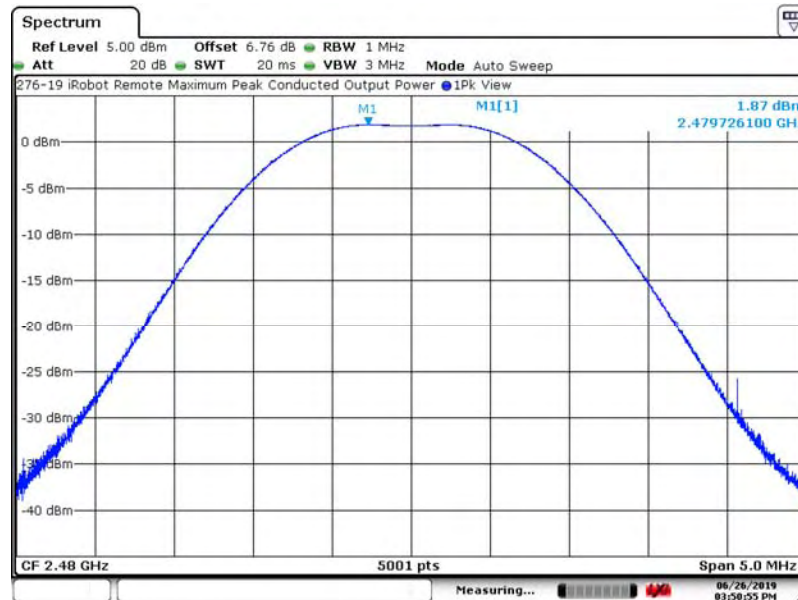

Date: 26.JUN.2019 15:50:55

7. Measurement Data

7.4. Operation with directional antenna gains greater than 6 dBi (15.247 (b)(4))

Requirement: If transmitting antennas of directional gain greater than 6 dBi are used, the conducted output power from the intentional radiator shall be reduced below the stated values in paragraphs (b)(1), (b)(2), and (b)(3) of FCC Part 15.247, as appropriate, by the amount in dB that the directional gain of the antenna exceeds 6 dBi.

Systems operating in the 2400 – 2483.5 MHz band that are used exclusively for fixed, point-to-point operations may employ transmitting antennas with directional gain greater than 6 dBi provided the maximum peak output power of the intentional radiator is reduced by 1 dB for every 3 dB that the directional gain of the antenna exceeds 6 dBi.

Systems operating in the 5725 – 5850 MHz band that are used exclusively for fixed, point-to-point operations may employ transmitting antennas with directional gain greater than 6 dBi without any corresponding reduction in transmitter peak output power.

Procedure: Not applicable for the device under test.

DUT Status: The DUT utilizes an antenna with a gain of less than 1 dBi and therefore is exempt from this requirement.

7. Measurement Data (continued)

7.5. Transmitter Spurious Radiated Emissions (30 kHz to 40 GHz) (FCC 15.209, ISED RSS-GEN 6.13)

7.5.1 Transmitter Spurious Radiated Emissions

Requirement: (15.209) The Emissions from an intentional radiator shall not exceed the field strength levels specified in the following table:

Frequency Range (MHz)	Distance (Meters)	Limit (dBµV/m) ¹
0.009 to 0.490	3	128.5 to 93.8
0.490 to 1.705	3	73.8 to 63.0
1.705 to 30	3	69.5
30 to 88	3	40.0
88 to 216	3	43.5
216 to 960	3	46.0
>960	3	54.0

¹Measurements in the 9 to 90 kHz, 110 to 490 kHz and above 1000 MHz ranges employ an average detector. Otherwise a quasi-peak detector is used.

Procedure: This test was performed in accordance with the procedure detailed in FCC OET publication number 558074, Section 12.0: Emissions in restricted frequency bands and FCC 47CFR Part 15.209: Radiated Emission Limits; General Requirements.

The test methods used to generate the data in this test report is in accordance with ANSI C63.10:2013, American National Standard for Testing Unlicensed Wireless Devices.

Test Notes: Measurements were made from the lowest oscillator frequency as stated by the manufacturer (32.768 kHz) to the 10th harmonic of the highest transmitter frequency or 40 GHz, whichever is lower.

Reference FCC Part 15.33(a) and FCC Part 15.33(a)(1).

Each of the test modes documented within the test report were evaluated and the worst case of each of the test modes is detailed in this section. A full set of measurement scans are presented in Appendix A of this test report.

Results: The Emissions from the DUT did not exceed the field strength levels specified in the above table.

Frequency Range	Worst-Case Measured Frequency	Field Strength	FCC Part 15.209 Limit	Margin	Reference	Receive Antenna Polarity
	(MHz)	(dBµV/m)	(dBµV/m)	(dB)	Appendix A	(H/V)
30 kHz - 150 kHz	0.03050	70.38	117.90	-47.52	A1.2.5	Perpendicular
150 kHz - 30 MHz	1.09725	52.14	66.85	-14.71	A2.3.4	Parallel
30 MHz - 1000 MHz	946.32000	40.07	46.00	-5.93	A3.3.1	H
1000 MHz - 10000 MHz	9925.750	47.69	74.00	-26.31	A4.2.1	H
10000 MHz - 18000 MHz	17908.190	47.96	74.00	-26.04	A5.1.4	V
18000 MHz - 25000 MHz	23725.580	46.81	74.00	-27.19	A6.2.5	H

7. Measurement Data (continued)

7.5. Transmitter Spurious Radiated Emissions (30 kHz to 40 GHz) (FCC 15.209, ISED RSS-GEN 6.13)

7.5.2. Transmitter Spurious Radiated Emissions (Harmonic Meas.) Test Results

Worst case measurements of Harmonics that fall into the restricted bands.

Freq. (MHz)	Field Strength (dB μ V/m)		Limit (dB μ V/m)		Margin (dB μ V/m)		Antenna Polarity (H/V)	Result
	Peak	Average	Peak	Average	Peak	Average		
4804	50.33	36.60	74.00	54.00	-23.67	-17.40	V	Compliant
4880	49.66	35.43	74.00	54.00	-24.34	-18.57	V	Compliant
4960	49.96	36.00	74.00	54.00	-24.04	-18.00	H	Compliant
7320	52.18	37.80	74.00	54.00	-21.82	-16.20	V	Compliant
7440	52.59	38.51	74.00	54.00	-21.41	-15.49	H	Compliant
12010	60.42	46.60	74.00	54.00	-13.58	-7.40	V	Compliant
12200	59.85	45.57	74.00	54.00	-14.15	-8.43	V	Compliant
12400	60.08	46.07	74.00	54.00	-13.92	-7.93	V	Compliant
19216	61.67	47.59	74.00	54.00	-12.33	-6.41	V	Compliant
19520	61.83	47.58	74.00	54.00	-12.17	-6.42	H	Compliant
19840	61.35	47.08	74.00	54.00	-12.65	-6.92	H	Compliant
22320	63.76	49.30	74.00	54.00	-10.24	-4.70	V	Compliant

¹ All correction factors are stored in the spectrum analyzer and applied to these column entries.

7. Measurement Data (continued)

7.6. Band Edge and Out of Band Measurements (FCC 15.209, ISED RSS-GEN 6.13)

Requirement: 15.247(d) In any 100 kHz bandwidth outside the frequency band in which the spread spectrum or digitally modulated intentional radiator is operating, the radio frequency power that is produced by the intentional radiator shall be at least 20 dB below that in the 100 kHz bandwidth within the band that contains the highest level of the desired power, based on either an RF conducted or a radiated measurement, provided the transmitter demonstrates compliance with the peak conducted power limits. If the transmitter complies with the conducted power limits based on the use of RMS averaging over a time interval, as permitted under paragraph (b)(3) of this section, the attenuation required under this paragraph shall be 30 dB instead of 20 dB. Attenuation below the general limits specified in Section 15.209(a) is not required. In addition, radiated emissions which fall in the restricted bands, as defined in Section 15.205(a), must also comply with the radiated emission limits specified in Section 15.209(a) (see Section 15.205(c)).

Procedure: For the lower band edge, this measurement was performed in accordance with the procedure detailed in FCC OET publication number 558074, Section 11: Emissions in non-restricted frequency bands.

For the upper band edge, this measurement was performed as a typical restricted band radiated emissions measurement above 1 GHz. Peak and CISPR average detectors and a 1 MHz resolution and 3 MHz video bandwidth were utilized.

Test Note: The radiated band edge and worst case out of band measurements in this report represent the measurements made with the worst case receive antenna polarity and product orthogonal position. In addition, the DTS bandwidth measurements were taken into consideration for the worst case examples.

Results: The DUT met the 20 dB requirement at the lower band edge and the Part 15.209 requirements at the upper band edge.

7.6.1. Lower Band Edge

Band Edge Frequency	Lowest Transmitter Frequency	Maximum PSD (100 kHz)	Band Edge Delta to Max PSD (100 kHz)	Minimum Required Delta	Result
(MHz)	(MHz)	(dBm)	(dB)	(dB)	
2400	2402	1.91	-45.28	-20	Compliant

Note: Reference the plot on the following page.

7. Measurement Data (continued)

7.6. Band Edge and Out of Band Measurements (continued)

Lower Band Edge

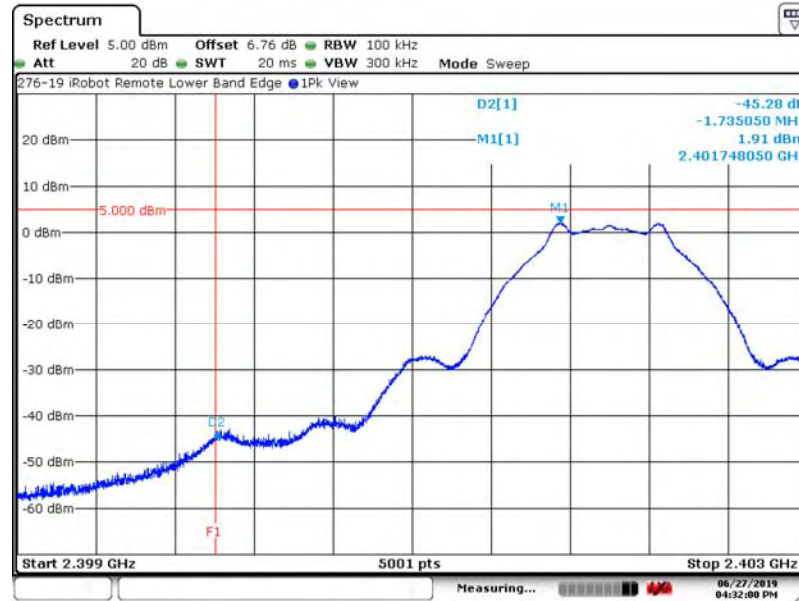

7.6.2. Upper Band Edge and Worst Case Out of Band

Upper Band Edge

Band Edge Frequency (MHz)	Field Strength (dB μ V/m)		Limit (dB μ V/m)		Margin (dB)		Result
	Peak	Average	Peak	Average	Peak	Average	
2483.5	64.61	48.82	74	54	-9.39	-5.18	Compliant

Worst Case Out of Band

Band Edge Frequency (MHz)	Out of Band Frequency (MHz)	Field Strength (dB μ V/m)		Limit (dB μ V/m)		Margin (dB μ V/m)		Result
		Peak	Average	Peak	Average	Peak	Average	
2483.5	2486.9322	65.97	48.97	74	54	-8.03	-5.03	Compliant

Note: Reference the plot on the following page.

7. Measurement Data (continued)

7.6. Band Edge and Out of Band Measurements (continued)

Upper Band Edge and Worst Case Out of Band

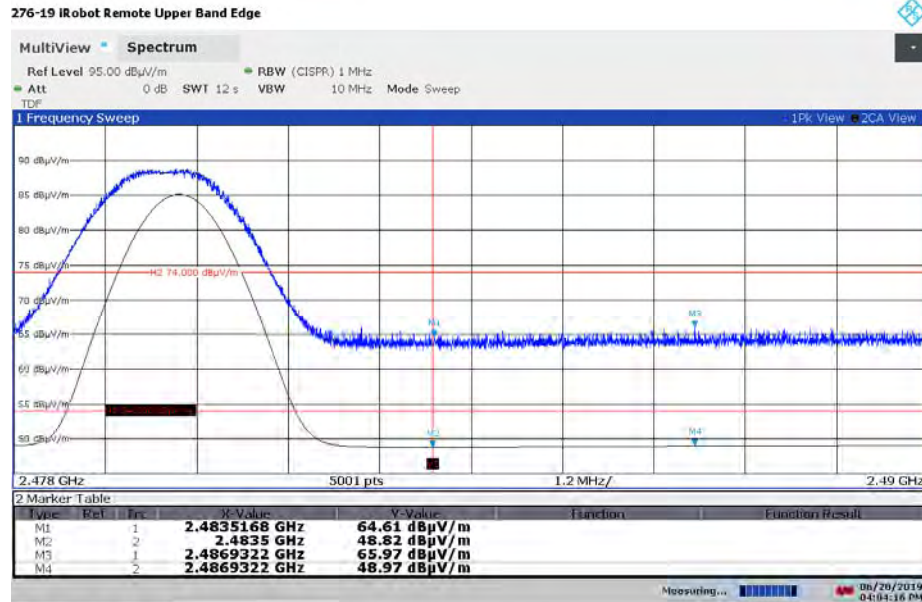

04:04:16 PM 06/28/2019

7.6.3. Lower Restricted Band, 2,310 MHz to 2390 MHz

Field Strength (dBµV/m)		Limit (dBµV/m)		Margin (dB)		Result
Peak	Average	Peak	Average	Peak	Average	
2351.36	65.41	52.14	74	54	-8.59	Compliant

Note: Reference the plot on the following page.

7.6.4. Upper Restricted Band, 2483.5 MHz, to 2500 MHz

Field Strength (dBµV/m)		Limit (dBµV/m)		Margin (dB)		Result
Peak	Average	Peak	Average	Peak	Average	
2495.6993	60.86	49.19	74	54	-13.14	Compliant

Reference the plot on the following page.

7. Measurement Data (continued)

7.6. Band Edge and Out of Band Measurements (continued)

Lower Restricted Band, 2310 MHz, to 2390 MHz

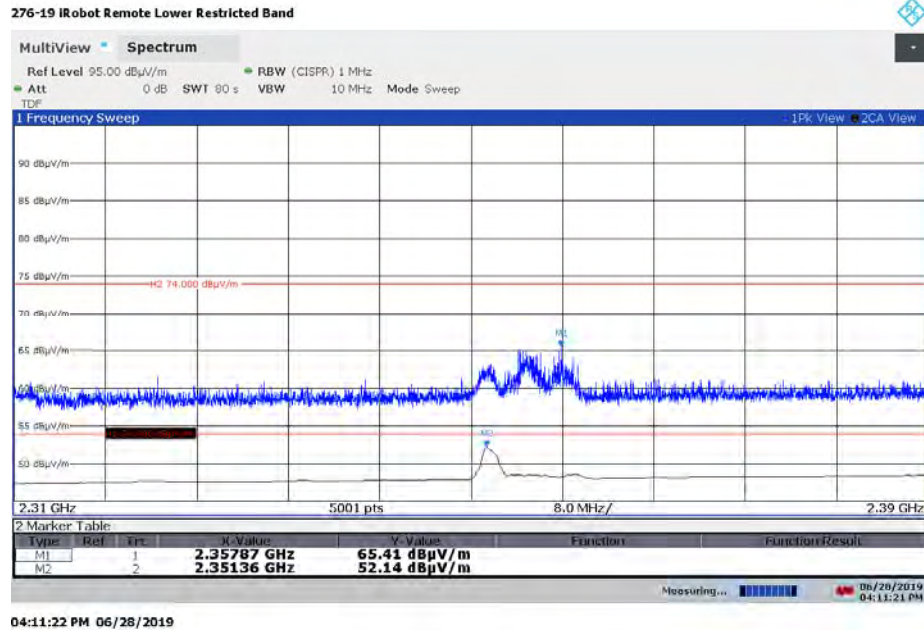

Upper Restricted Band, 2483.5 MHz, to 2500 MHz

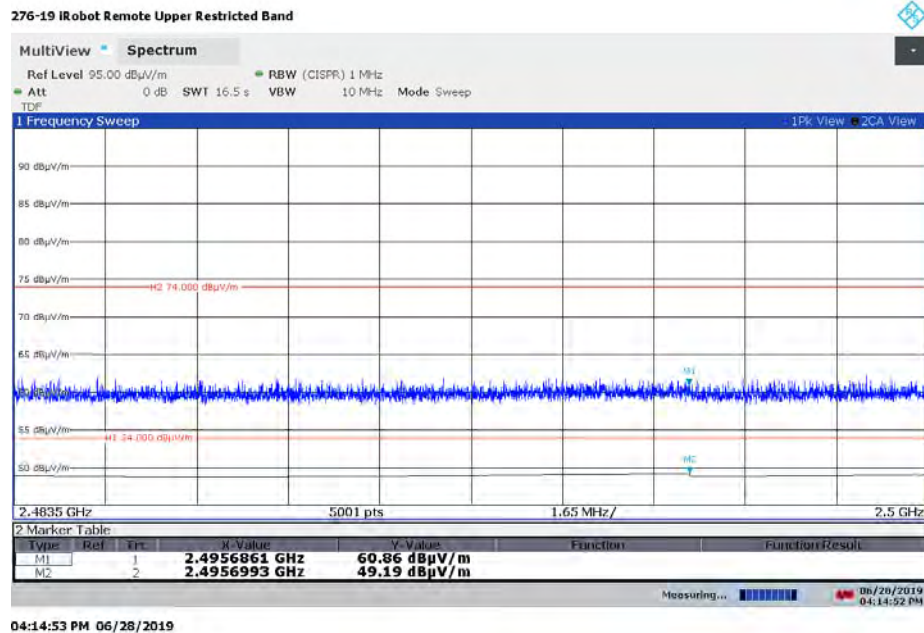

7. Measurement Data (continued)

7.7. Emissions in Non-restricted Frequency Bands

Requirement: 15.247(d) In any 100 kHz bandwidth outside the frequency band in which the spread spectrum or digitally modulated intentional radiator is operating, the radio frequency power that is produced by the intentional radiator shall be at least 20 dB below that in the 100 kHz bandwidth within the band that contains the highest level of the desired power, based on either an RF conducted or a radiated measurement, provided the transmitter demonstrates compliance with the peak conducted power limits.

Test Notes: Peak in-band measurements were taken at the time the DTS (-6 dB) bandwidth measurements were made. These values were used as the reference levels for the following measurements. Refer to section 7.2 of this report for these values.

Results: The DUT met the 20 dB requirement emission level delta requirement in the non restricted frequency bands.

Emissions in Non-restricted Frequency Bands

Maximum PSD (100 kHz) In-Band ¹ (dBμV/m)	Worst Case Out-of-Band Frequency (MHz)	Maximum PSD (100 kHz) Out-of-Band (dBμV/m)	Delta to Maximum PSD (dB)	Minimum Required Delta (dB)	Result
2.00	4804.5	-52.61	-54.61	-18.00	Compliant

¹Taken from Section 7.2 - DTS Bandwidth

7. Measurement Data (continued)

7.8. Peak Power Spectral Density (FCC 15.247(e), ISED RSS-247, 5.2 b))

Requirement: For digitally modulated systems, the power spectral density conducted from the intentional radiator to the antenna shall not be greater than 8 dBm (103.2 dBµV/m) in any 3 kHz band during any time interval of continuous transmission. This power spectral density shall be determined in accordance with the provisions of paragraph (b) of FCC Part 15.247. The same method of determining the conducted output power shall be used to determine the power spectral density.

Procedure: FCC OET publication number 558074, Section 10.2: Method PKPSD (peak PSD). FCC OET 662911 was referenced to determine the procedure for measuring in-band power spectral density of transmitters with multiple outputs in the same band.

Results: The DUT met the required power spectral density limit at the tested frequencies.

Measurement Results in 2400 MHz to 2483.5 MHz Band

Channel	Frequency	Maximum PSD Frequency	Maximum Power Spectral Density	Limit	Margin	Result
	(MHz)	(MHz)	(dBµV/m)	(dBµV/m)	(dB)	
37	2402	2402.0064	-7.77	8	-15.77	Compliant
17	2440	2425.9787	-8.10	8	-16.10	Compliant
39	2480	2480.1515	-8.01	8	-16.01	Compliant

7. Measurement Data (continued)

7.8. Peak Power Spectral Density (15.247(e)), ISED RSS-247, 5.2 b)) (continued)

7.8.1. Low Channel – 37, 2402 MHz

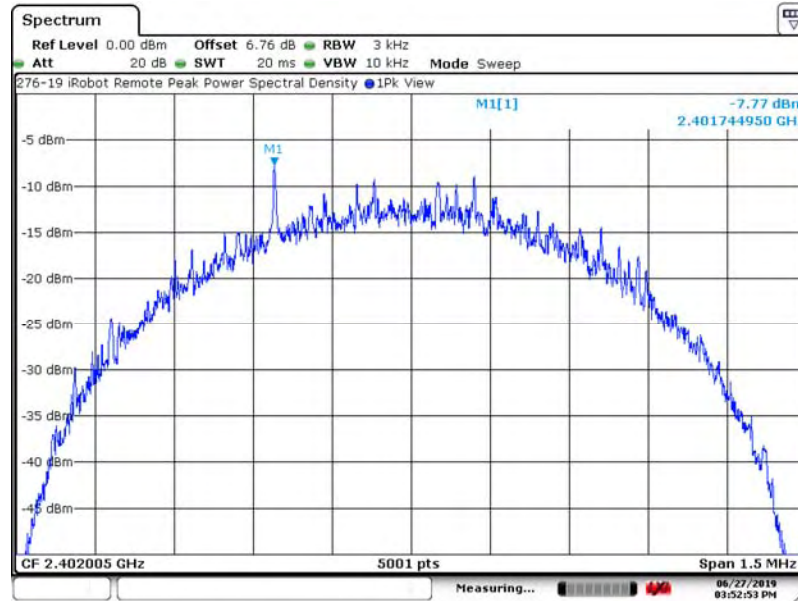

7.8.2. Middle Channel – 38, 2426 MHz

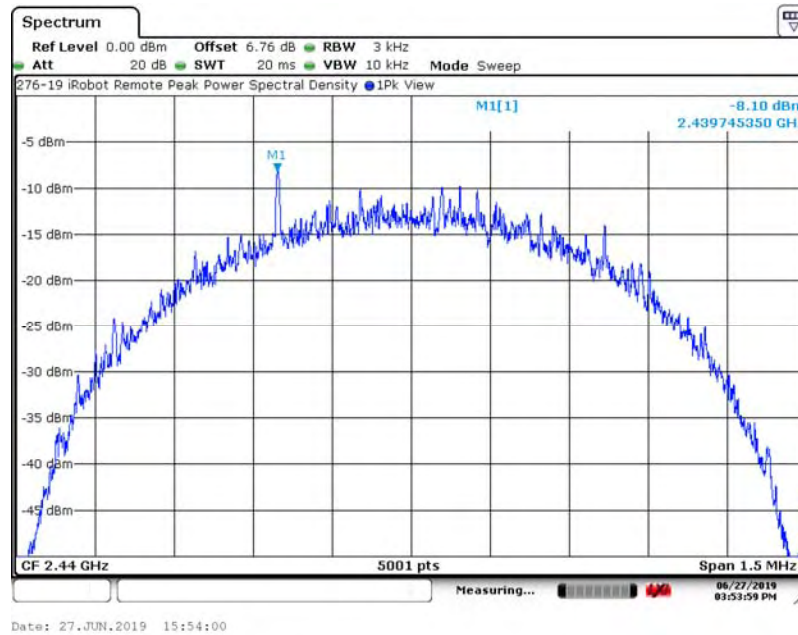

7. Measurement Data

7.8. Peak Power Spectral Density (15.247(e)), ISED RSS-247, 5.2 b)) (continued)

7.8.3. High Channel – 39, 2480 MHz

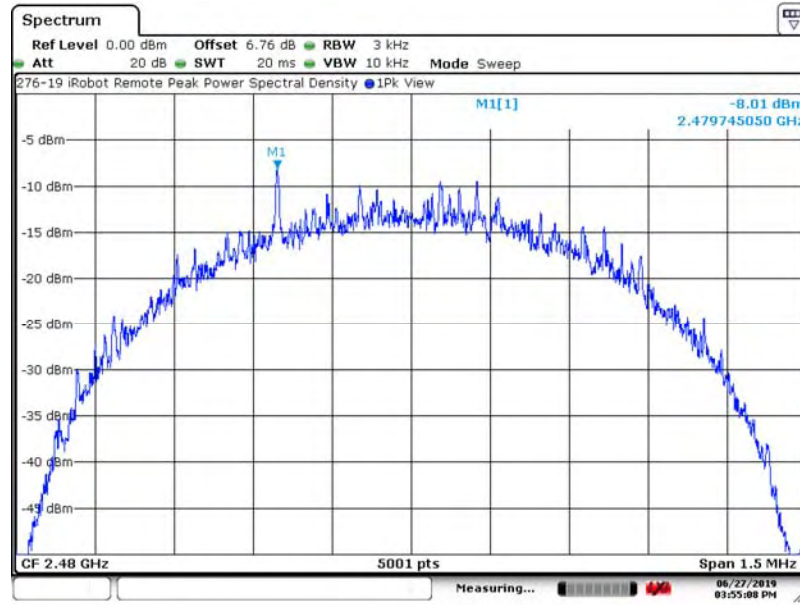

Date: 27.JUN.2019 15:55:09

7. Measurement Data (continued)

7.9. Duty Cycle

Requirement: (FCC OET publication number 558074)

Preferably, all measurements of maximum conducted (average) output power will be performed with the EUT transmitting continuously (i.e., with a duty cycle of greater than or equal to 98%).

Procedure: Duty cycle measurements were made according to the procedure detailed ANSI C63.10-2013, Section 11.6(b)

Results: Duty cycle measurements are listed in the following table.

All power and power spectral density measurements for this report are peak mode measurements. Ample peak hold time was provided to ensure maximum peak measurements.

Channel	Frequency	Time High	Time per Period	Duty Cycle	
				(Numeric)	(%)
37	2402	100.000	100.000	1.0	100.00
17	2440	100.000	100.000	1.0	100.00
39	2480	100.000	100.000	1.0	100.00

7.9.1. Low Channel – 37, 2402 MHz

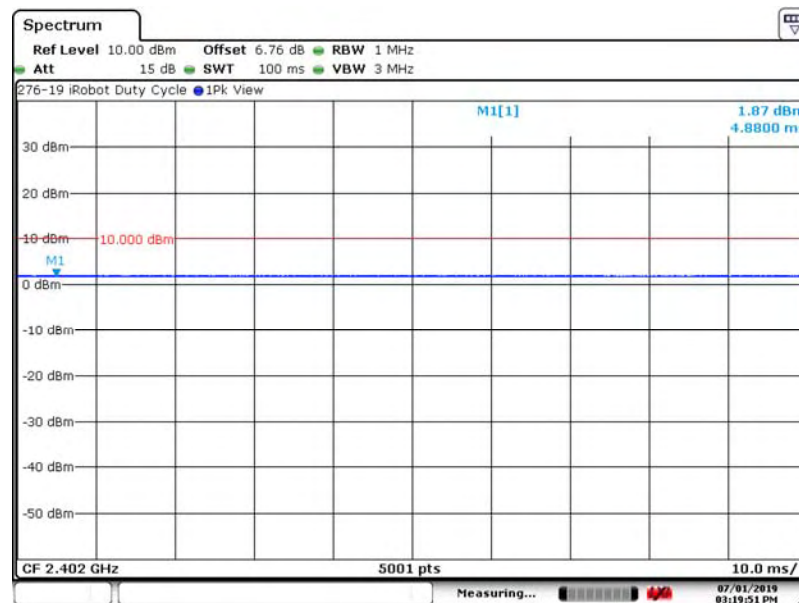

Date: 1.JUL.2019 15:19:52

7. Measurement Data (continued)

7.9. Duty Cycle (continued)

7.9.2. Middle Channel – 38, 2426 MHz

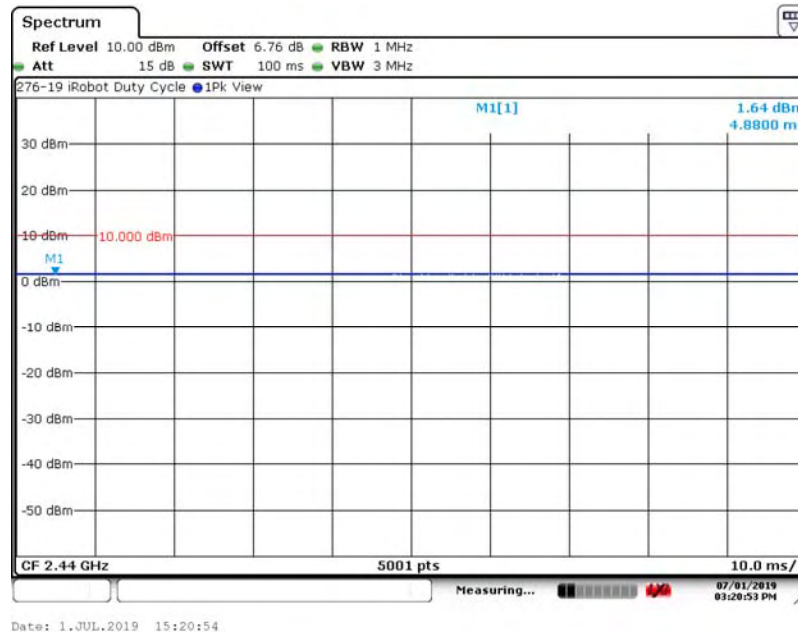

7.9.3. High Channel – 39, 2480 MHz

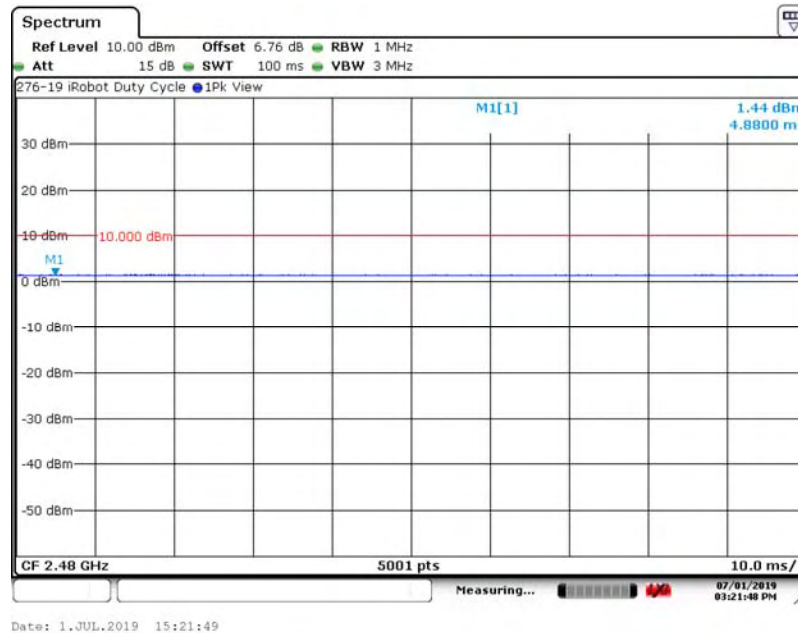

7. Measurement Data (continued)

7.10. 99% (Occupied) Bandwidth (RSS-GEN 6.7)

Requirement: The occupied bandwidth shall be reported for all equipment in addition to the specified bandwidth required in the applicable RSSs.

The resolution bandwidth (RBW) shall be in the range of 1% to 5% of the actual occupied / x dB bandwidth and the video bandwidth (VBW) shall not be smaller than three times the RBW value.

The sample detector of the spectrum analyzer shall be used to make the measurement.

7.10.1. Measurement Results

Channel	Channel Frequency (MHz)	99% Power Bandwidth (MHz)
Low	2402	1.0606
Middle	2440	1.0630
High	2480	1.0858

7.10.1.1. 99% Power Bandwidth – Low Frequency (2402 MHz)

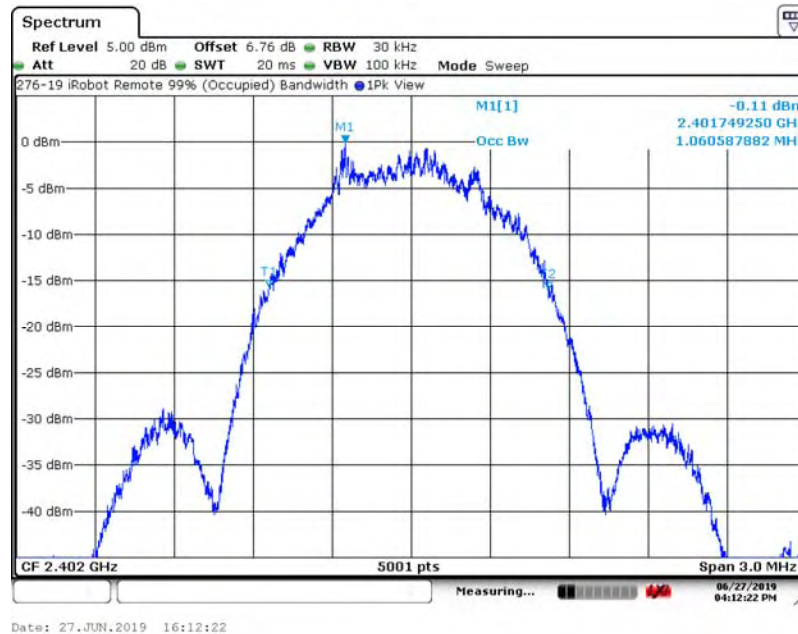

7. Measurement Data (continued)

7.10. 99% (Occupied) Bandwidth (RSS-GEN 6.7)

7.10.1.2. 99% Power Bandwidth – Middle Frequency (2441 MHz)

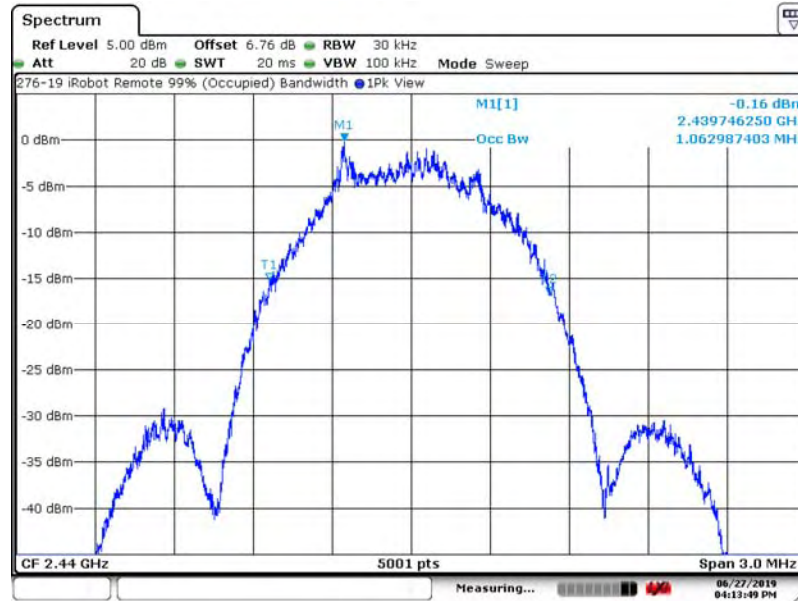

7.10.1.3. 99% Power Bandwidth – High Frequency (2480 MHz)

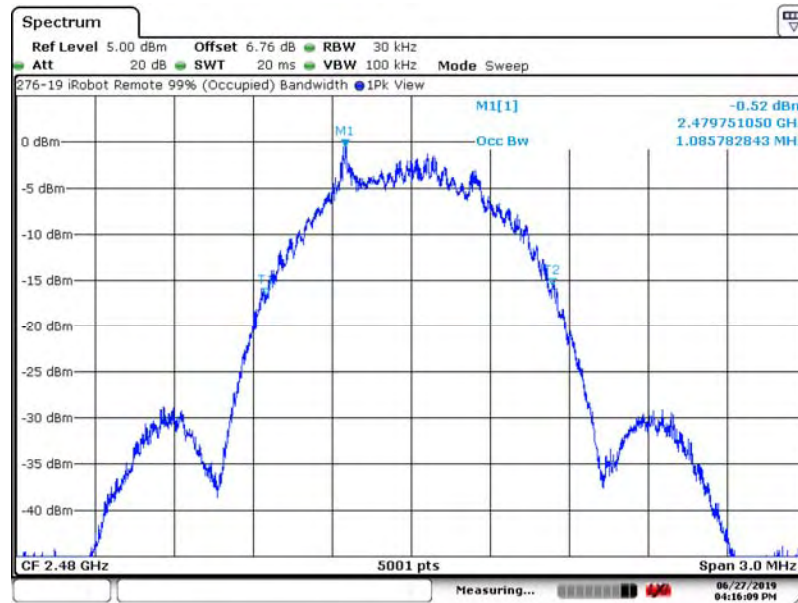

7. Measurement Data (continued)

**7.11. Public Exposure to Radio Frequency Energy Levels (15.247(i) (1.1307 (b)(1))
RSS-GEN, ISSUE 4 5.5, RSS-102)**

7.11.1. 15.247(i) (1.1307 (b)(1) Requirements

Requirement: Portable devices are subject to radio frequency radiation exposure requirements.

For a 1-g head or body SAR, the test exclusion result must be ≤ 3.0 .

For a 10-g extremity SAR, the test exclusion result must be ≤ 7.5 .

Test Notes: The 1-g and 10-g SAR test exclusion thresholds for 100 MHz to 6 GHz at test separation distances ≤ 50 mm are determined by the following formula:

$$\text{SAR Test Exclusion} = \frac{P_{\text{MAX}}}{d_{\text{MIN}}} \times \sqrt{f_{(\text{GHz})}} \quad (1)$$

P_{MAX} mW Maximum power of channel, including tune-up tolerance

d_{MIN} mm Minimum test separation distance, mm (≤ 50 mm)

$f_{(\text{GHz})}$ GHz $f_{(\text{GHz})}$ is the RF channel transmit frequency in GHz (>100 MHz and <6 GHz)

(1) FCC OET 447498 - Mobile and Portable Devices RF Exposure Procedures and Equipment Authorization Policies.

Results: Passed - The device under test meets the exclusion requirement detailed in FCC OET 447498.

Channel:		37	17	39	
Input ¹ :	P_{MAX}	1.663	1.611	1.538	mW
	d_{MIN}^2	5.00	5.00	5.00	mm
	$f_{(\text{GHz})}$	2.402	2.440	2.480	GHz
Test Exclusion:		0.52	0.50	0.48	
Limit Exemption:		3.0	3.0	3.0	
Measurement Result:		Compliant	Compliant	Compliant	

¹ Taken from column 3 of the table in Section 7.3 of this test report.

² When the minimum test separation distance is < 5 mm, a distance of 5 mm according to KDB 447498, 4.1 f) is applied to determine SAR test exclusion.

Note: BLE and UWB Radios do not transmit simultaneously.

7.11.2. IC RSS-102 Issue 5 SAR Evaluation (Reference RSS-102, Table 1)

Frequency	Separation Distance	Maximum Power	RSS-102 Limit	Result
MHz	mm	mW	mW	
2402	≤ 5	1.66	10.65	Compliant
2440	≤ 5	1.61	10.14	Compliant
2480	≤ 5	1.54	9.86	Compliant

8. Test Site Description

Compliance Worldwide is located at 357 Main Street in Sandown, New Hampshire. The test sites at Compliance Worldwide are used for conducted and radiated emissions testing in accordance with the Federal Communications Commission (FCC) and Industry Canada standards. Through our American Association for Laboratory Accreditation (A2LA) ISO Guide 17025:2005 Accreditation our test sites are designated with the FCC (designation number **US1091**), Industry Canada (file number **IC 3023A-1**) and VCCI (Member number 3168) under registration number A-0274.

Compliance Worldwide is also designated as a Phase 1 CAB under APEC-MRA (US0132) for Australia/New Zealand AS/NZS CISPR 22, Chinese-Taipei (Taiwan) BSMI CNS 13438 and Korea (RRA) KN 11, KN 13, KN 14-1, KN 22, KN 32, KN 61000-6-3, KN 61000-6-4.

The radiated emissions test site is a 3 and 10 meter enclosed open area test site (OATS). Personnel, support equipment and test equipment are located in the basement beneath the OATS ground plane.

The conducted emissions site is part of a 16' x 20' x 12' ferrite tile chamber and uses one of the walls for the vertical ground plane. A second conducted emissions site is also located in the basement of the OATS site with a 2.3 x 2.5 meter ground plane and a 2.4 x 2.4 meter vertical wall.

Both sites are designed to test products or systems 1.5 meters W x 1.5 meters L x 2.0 meters H, floor standing or table top.

Appendix A - Transmitter Spurious Radiated Emissions (30 kHz to 25 GHz)

A1. Spurious Radiated Emissions (30 kHz – 150 kHz) Test Results

A1.1. Channel 37, 2402 MHz

A1.1.1. Measurement Results: X-Axis, Parallel Antenna

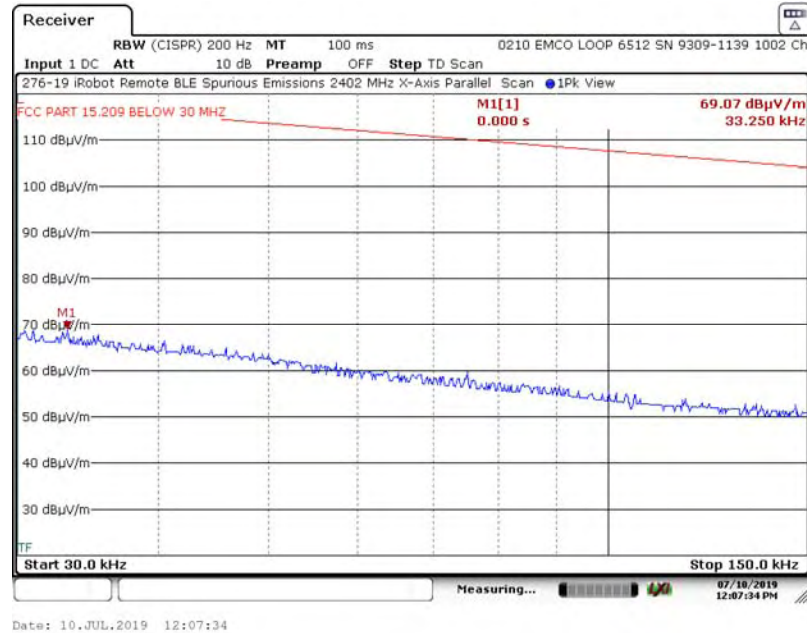

A1.1.2. Measurement Results: X-Axis, Perpendicular Antenna

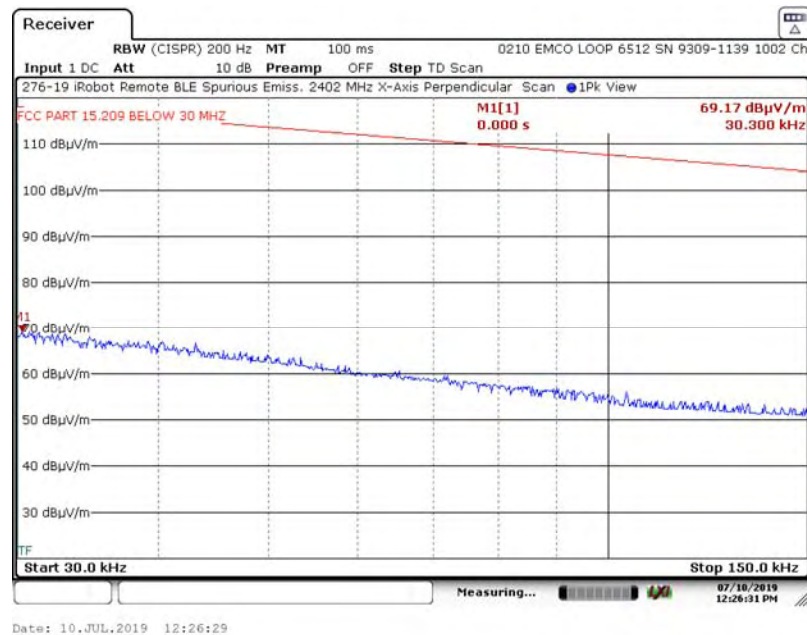

Appendix A - Transmitter Spurious Radiated Emissions (30 kHz to 25 GHz)

A1. Spurious Radiated Emissions (30 kHz – 150 kHz) Test Results

A1.1. Channel 37, 2402 MHz

A1.1.3. Measurement Results: X-Axis, Ground-Parallel Antenna

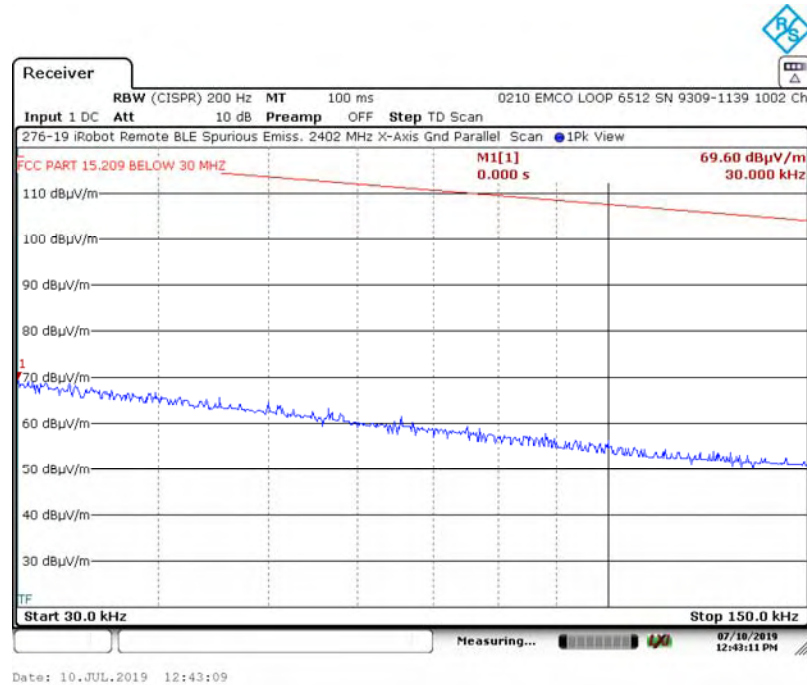

A1.1.4. Measurement Results: Y-Axis, Parallel Antenna

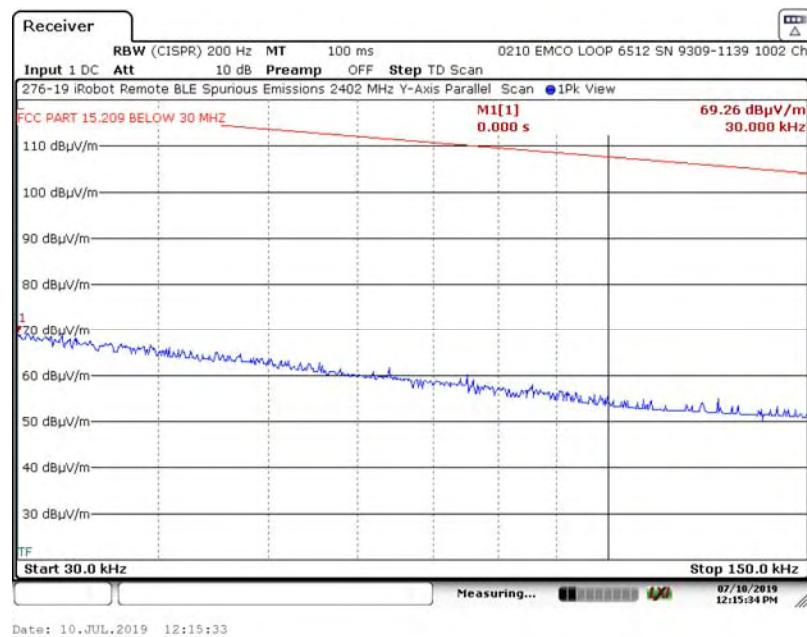

Appendix A - Transmitter Spurious Radiated Emissions (30 kHz to 25 GHz)

A1. Spurious Radiated Emissions (30 kHz – 150 kHz) Test Results

A1.1. Channel 37, 2402 MHz

A1.1.5. Measurement Results: Y-Axis, Perpendicular Antenna

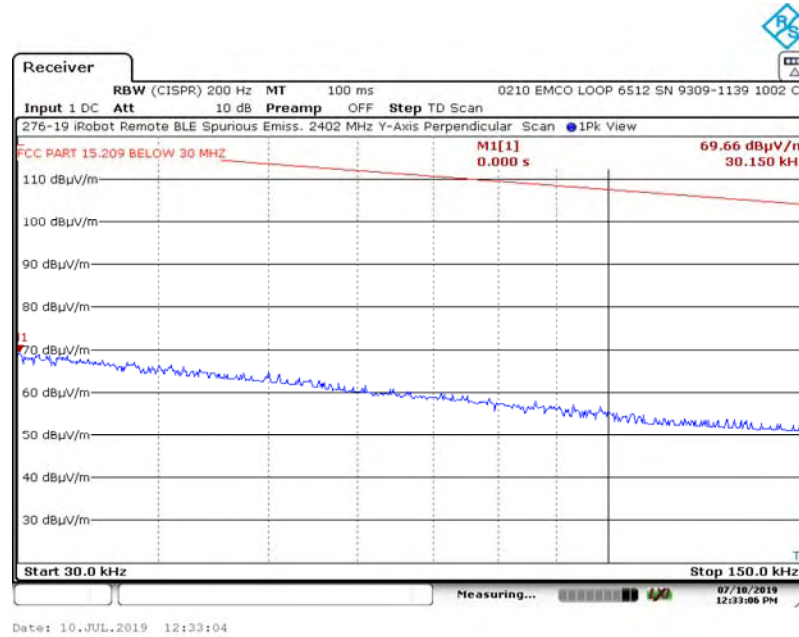

A1.1.6. Measurement Results: Y-Axis, Ground-Parallel Antenna

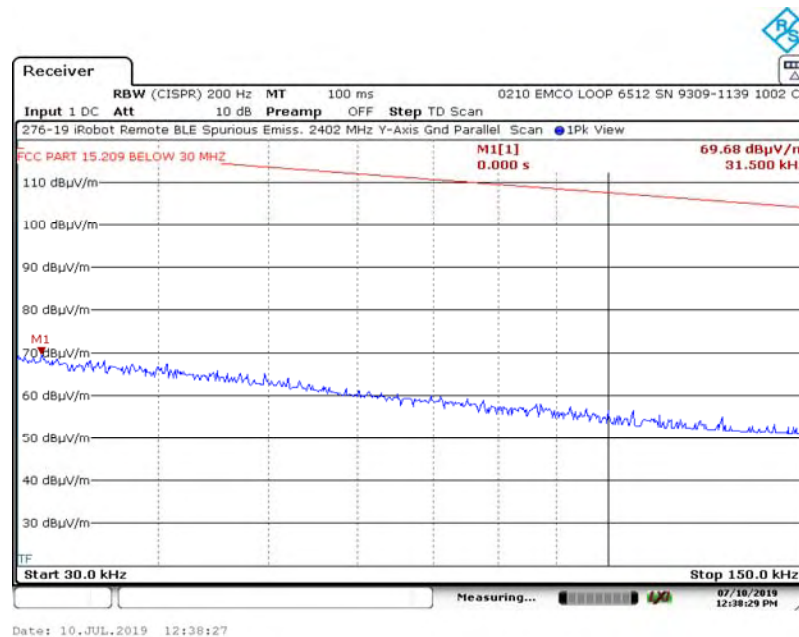

Appendix A - Transmitter Spurious Radiated Emissions (30 kHz to 25 GHz)

A1. Spurious Radiated Emissions (30 kHz – 150 kHz) Test Results

A1.1. Channel 37, 2402 MHz

A1.1.7. Measurement Results: Z-Axis, Parallel Antenna

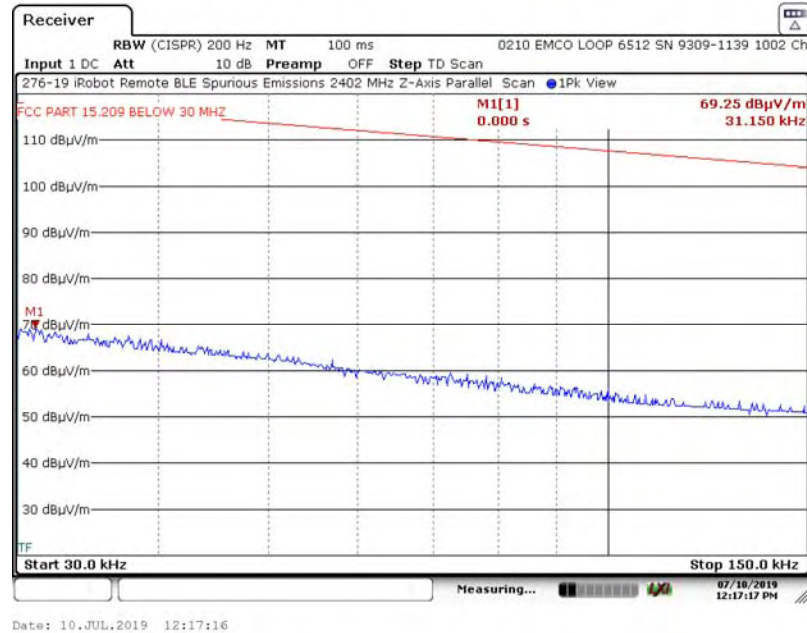

A1.1.8. Measurement Results: Z-Axis, Perpendicular Antenna

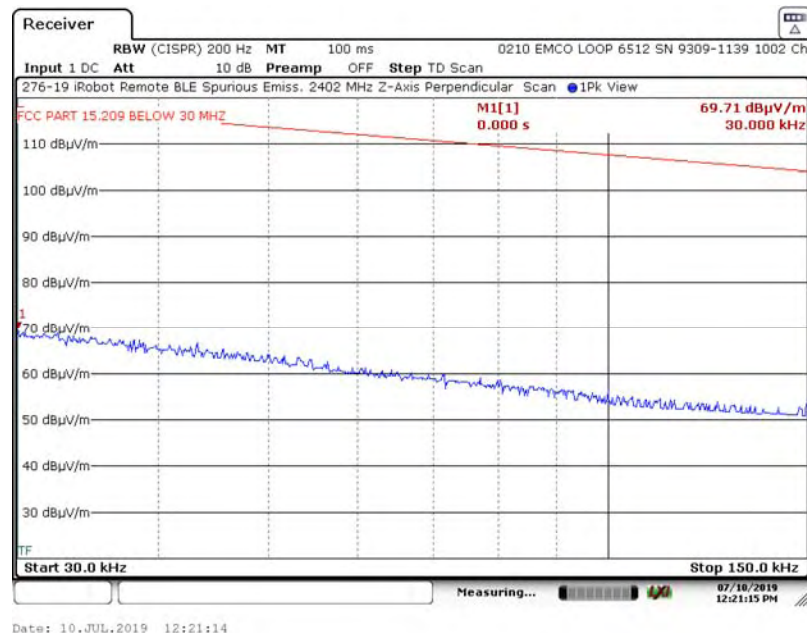

Appendix A - Transmitter Spurious Radiated Emissions (30 kHz to 25 GHz)

A1. Spurious Radiated Emissions (30 kHz – 150 kHz) Test Results

A1.1. Channel 37, 2402 MHz

A1.1.9. Measurement Results: Z-Axis, Ground Parallel Antenna

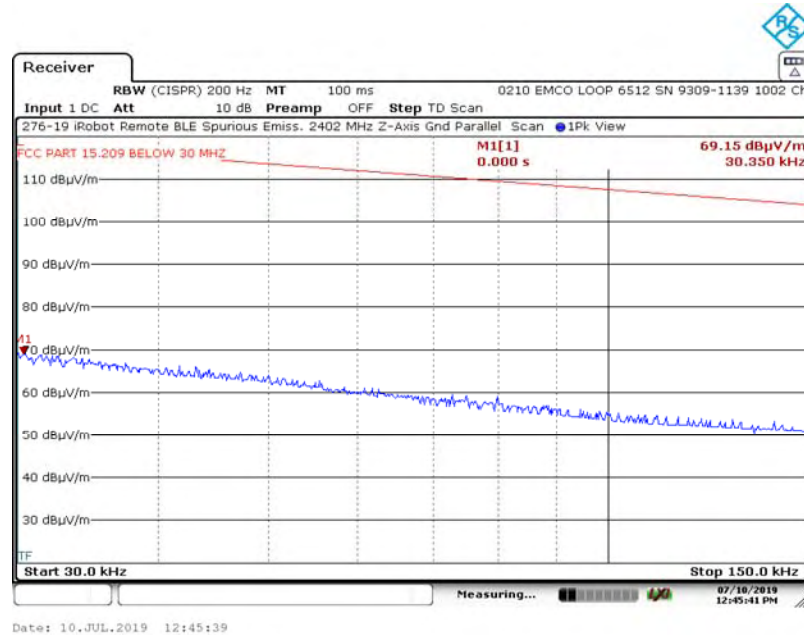

Appendix A - Transmitter Spurious Radiated Emissions (30 kHz to 25 GHz)

A1. Spurious Radiated Emissions (30 kHz – 150 kHz) Test Results

A1.2. Channel 17, 2440 MHz

A1.2.1. Measurement Results: X-Axis, Parallel Antenna

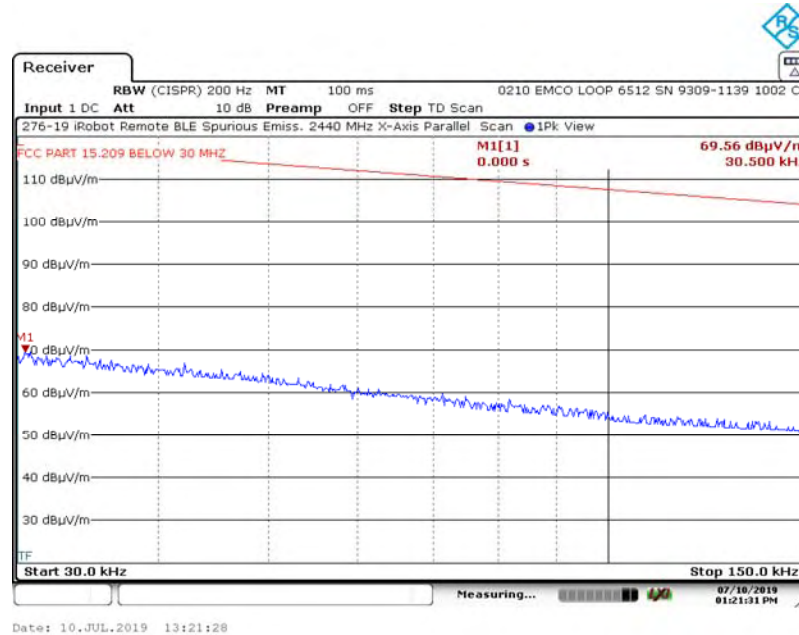

A1.2.2. Measurement Results: X-Axis, Perpendicular Antenna

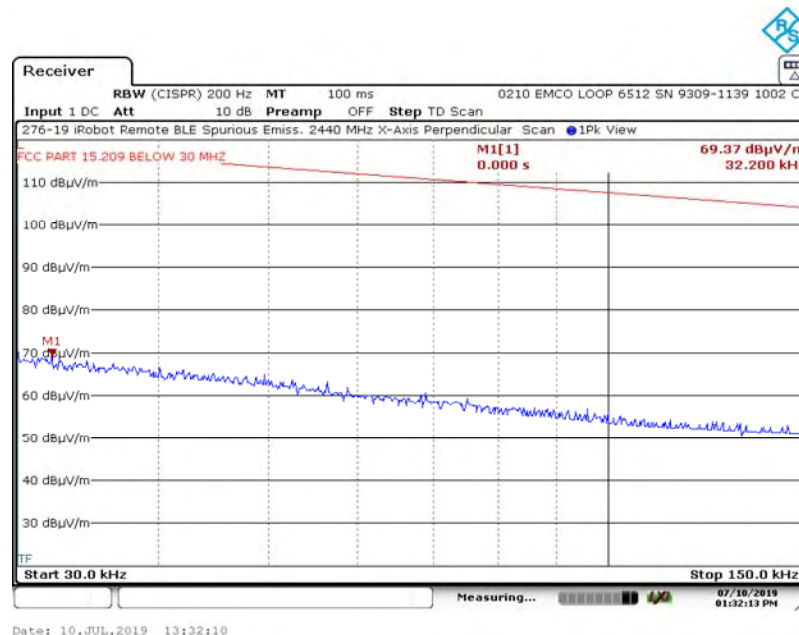

Appendix A - Transmitter Spurious Radiated Emissions (30 kHz to 25 GHz)

A1. Spurious Radiated Emissions (30 kHz – 150 kHz) Test Results

A1.2. Channel 17, 2440 MHz

A1.2.3. Measurement Results: X-Axis, Ground-Parallel Antenna

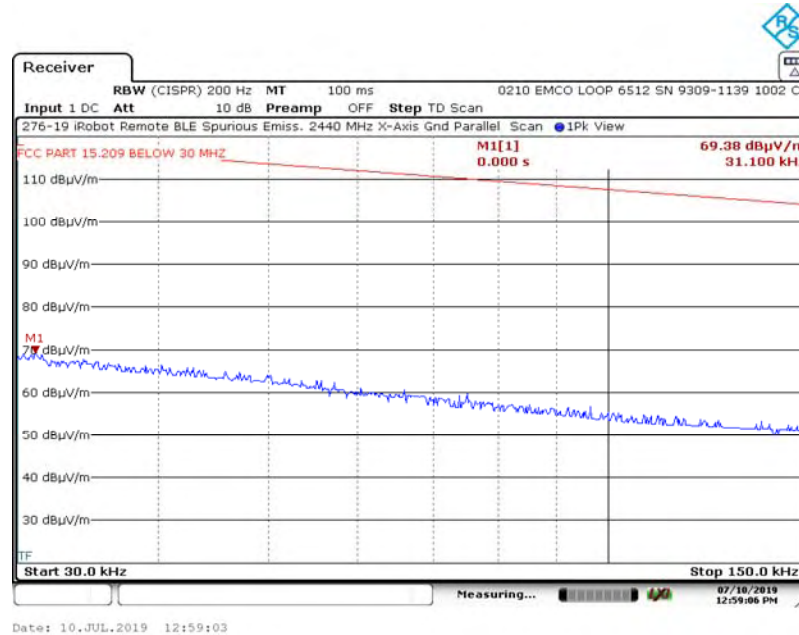

A1.2.4. Measurement Results: Y-Axis, Parallel Antenna

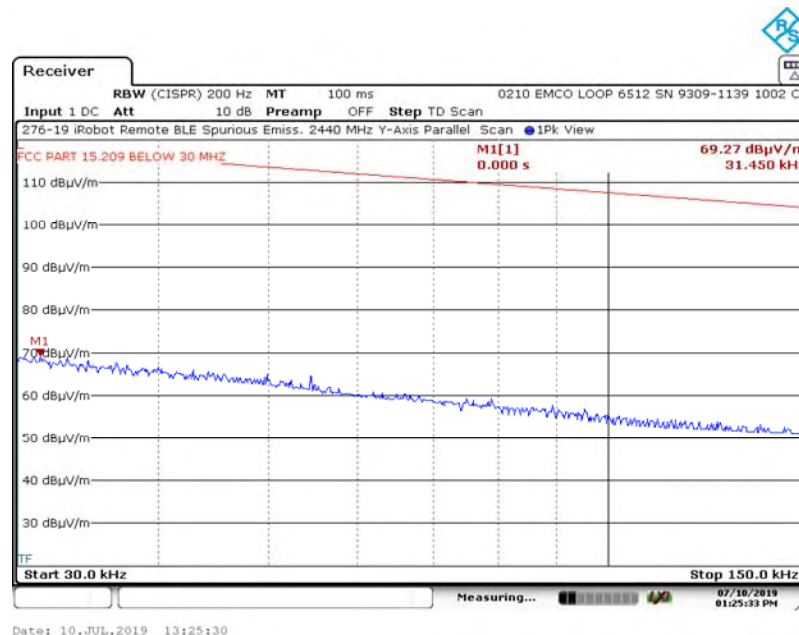

Appendix A - Transmitter Spurious Radiated Emissions (30 kHz to 25 GHz)

A1. Spurious Radiated Emissions (30 kHz – 150 kHz) Test Results

A1.2. Channel 17, 2440 MHz

A1.2.5. Measurement Results: Y-Axis, Perpendicular Antenna

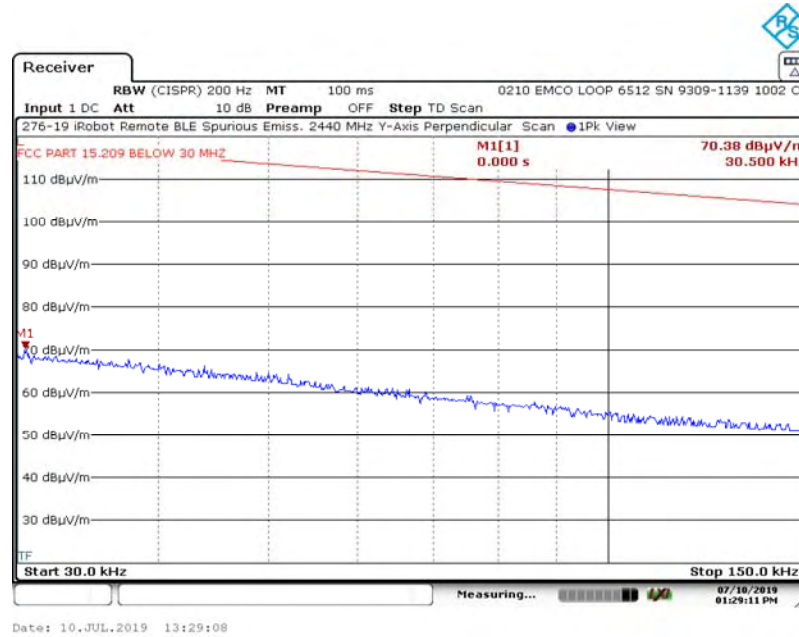

A1.2.6. Measurement Results: Y-Axis, Ground-Parallel Antenna

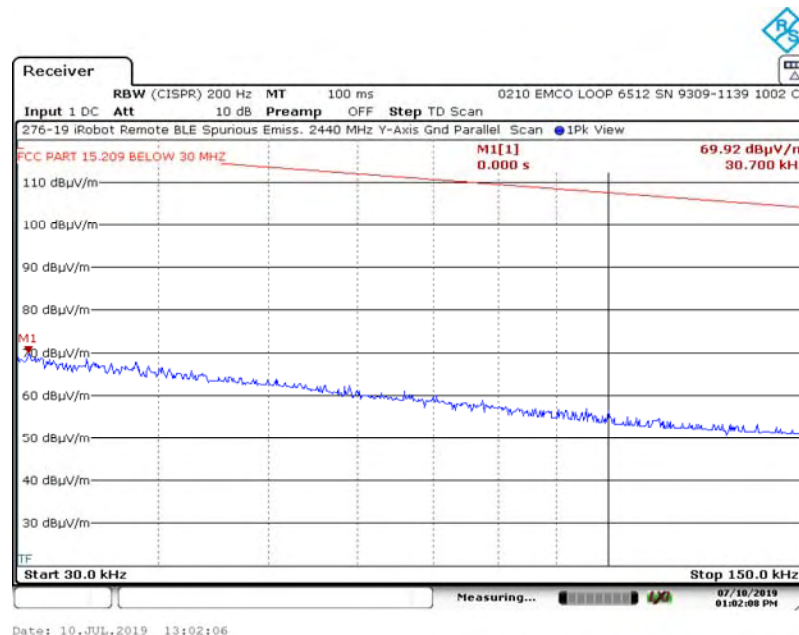

Appendix A - Transmitter Spurious Radiated Emissions (30 kHz to 25 GHz)

A1. Spurious Radiated Emissions (30 kHz – 150 kHz) Test Results

A1.2. Channel 17, 2440 MHz

A1.2.7. Measurement Results: Z-Axis, Parallel Antenna

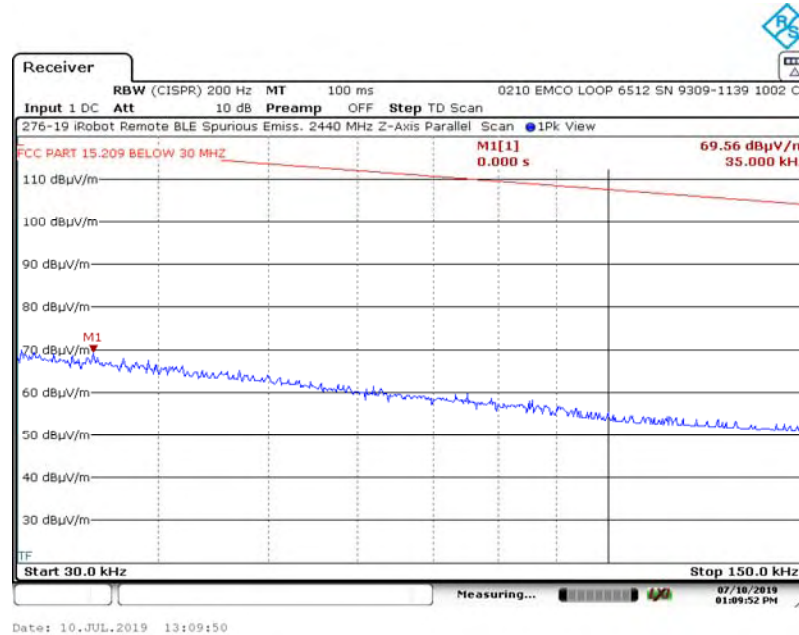

A1.2.8. Measurement Results: Z-Axis, Perpendicular Antenna

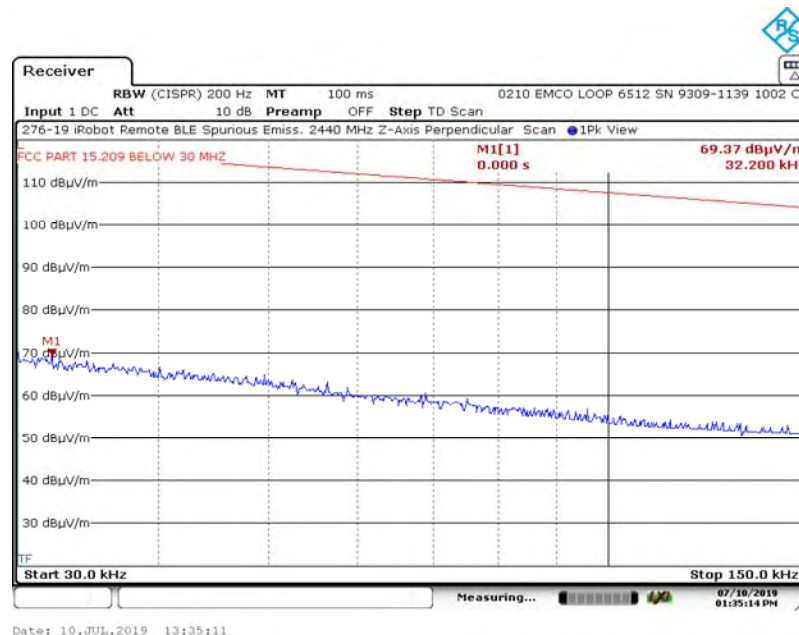

Appendix A - Transmitter Spurious Radiated Emissions (30 kHz to 25 GHz)

A1. Spurious Radiated Emissions (30 kHz – 150 kHz) Test Results

A1.2. Channel 17, 2440 MHz

A1.2.9. Measurement Results: Z-Axis, Ground Parallel Antenna

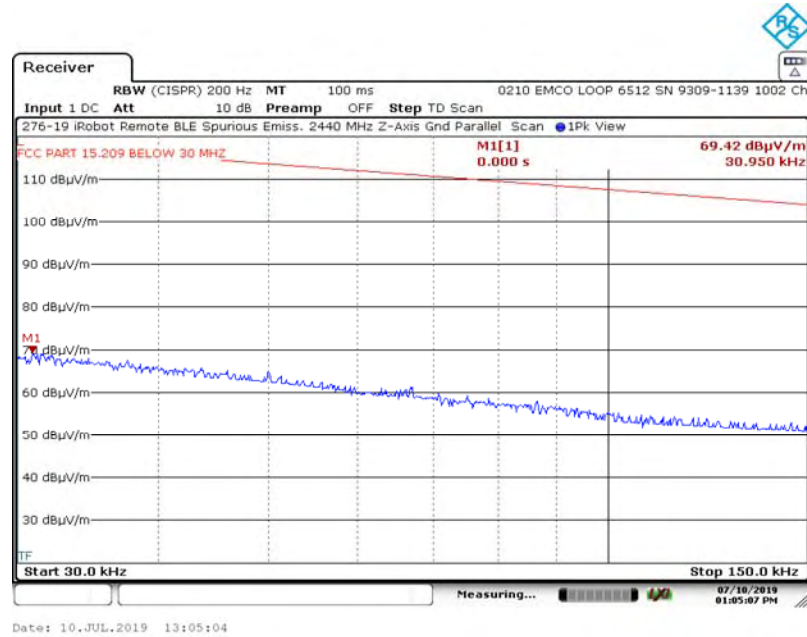

Appendix A - Transmitter Spurious Radiated Emissions (30 kHz to 25 GHz)

A1. Spurious Radiated Emissions (30 kHz – 150 kHz) Test Results

A1.3. Channel 39, 2480 MHz

A1.3.1. Measurement Results: X-Axis, Parallel Antenna

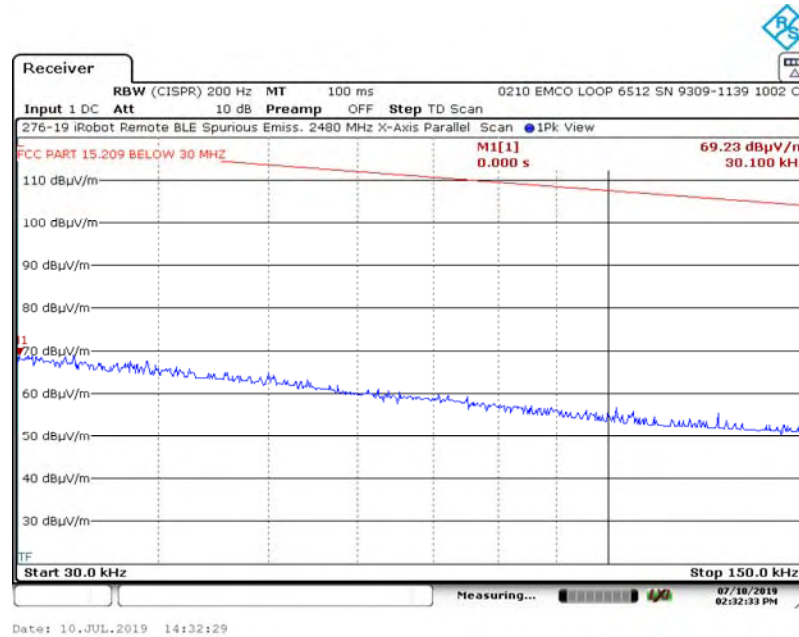

A1.3.2. Measurement Results: X-Axis, Perpendicular Antenna

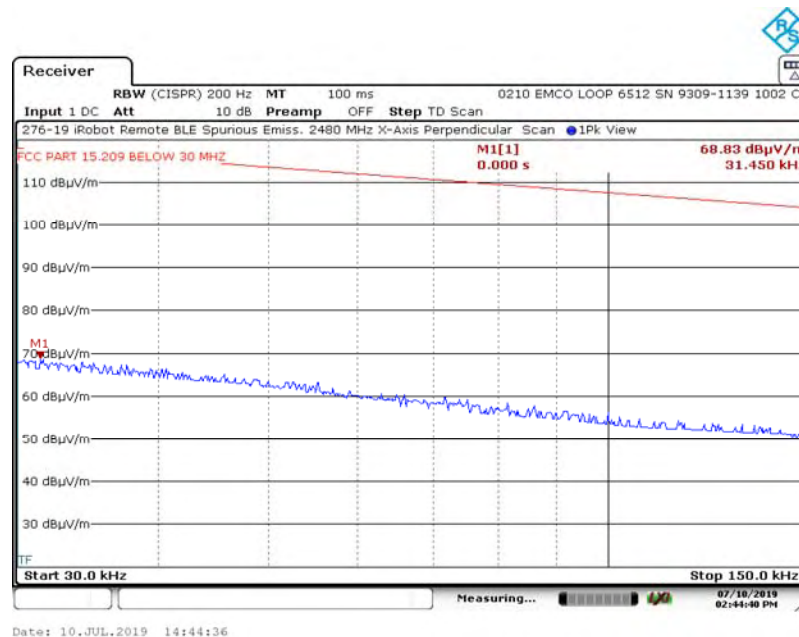

Appendix A - Transmitter Spurious Radiated Emissions (30 kHz to 25 GHz)

A1. Spurious Radiated Emissions (30 kHz – 150 kHz) Test Results

A1.3. Channel 39, 2480 MHz

A1.3.3. Measurement Results: X-Axis, Ground-Parallel Antenna

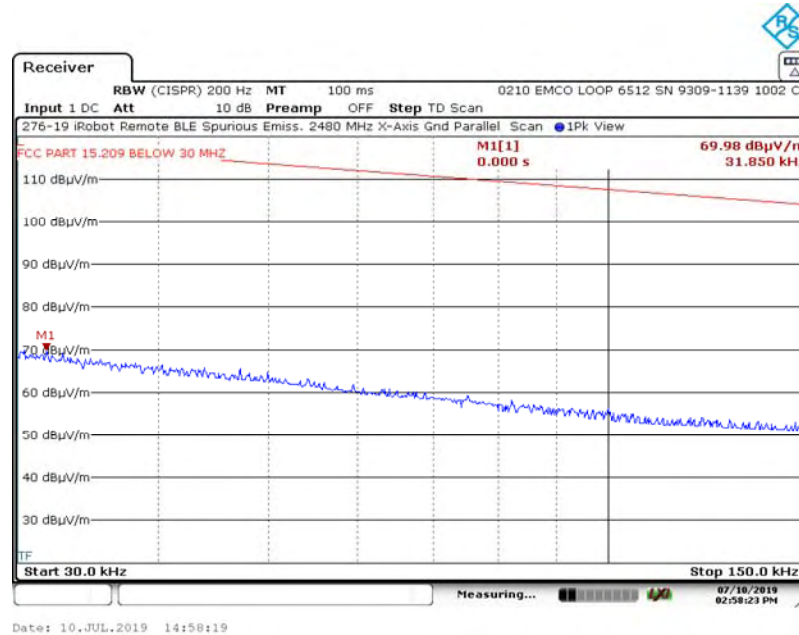

A1.3.4. Measurement Results: Y-Axis, Parallel Antenna

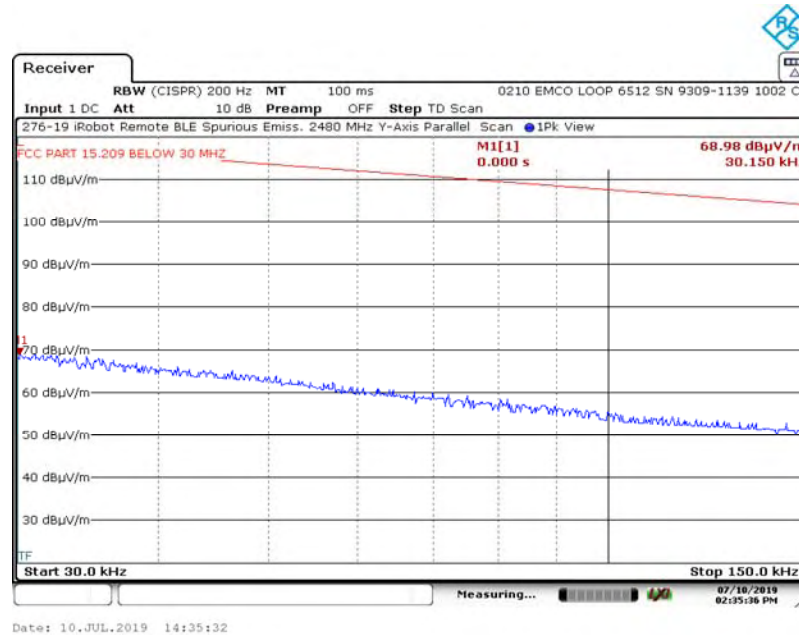

Appendix A - Transmitter Spurious Radiated Emissions (30 kHz to 25 GHz)

A1. Spurious Radiated Emissions (30 kHz – 150 kHz) Test Results

A1.3. Channel 39, 2480 MHz

A1.3.5. Measurement Results: Y-Axis, Perpendicular Antenna

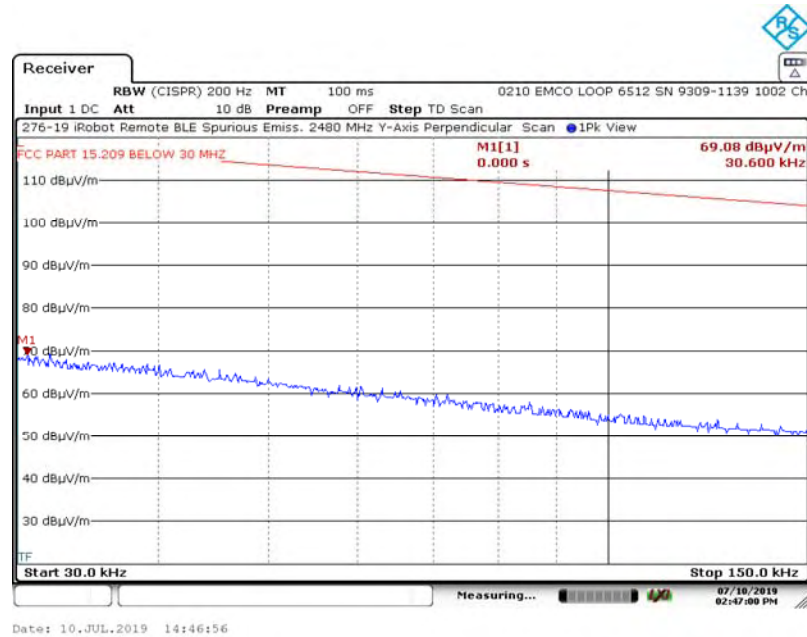

A1.3.6. Measurement Results: Y-Axis, Ground-Parallel Antenna

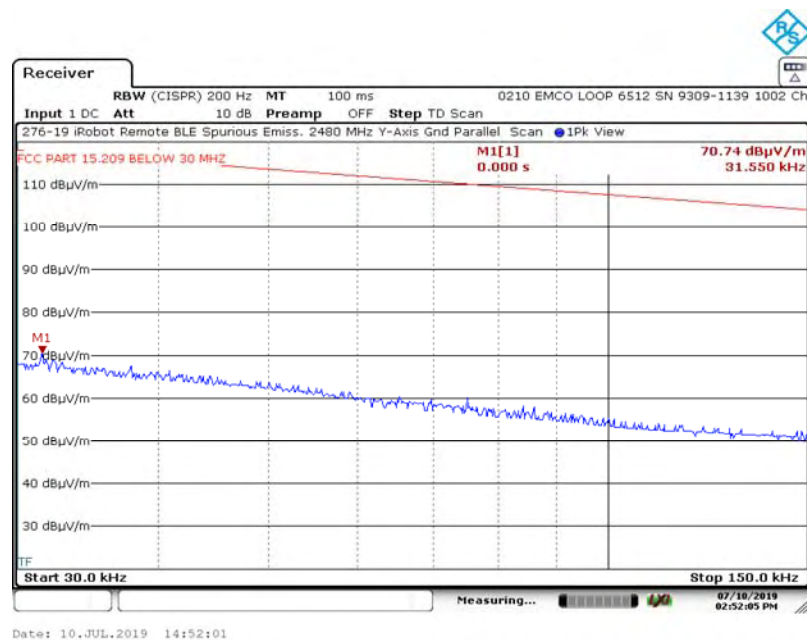

Appendix A - Transmitter Spurious Radiated Emissions (30 kHz to 25 GHz)

A1. Spurious Radiated Emissions (30 kHz – 150 kHz) Test Results

A1.3. Channel 39, 2480 MHz

A1.3.7. Measurement Results: Z-Axis, Parallel Antenna

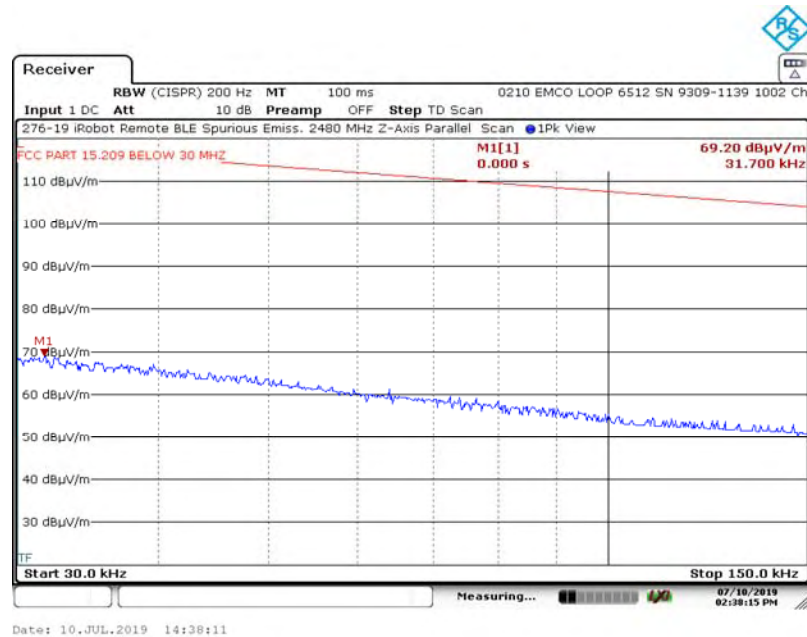

A1.3.8. Measurement Results: Z-Axis, Perpendicular Antenna

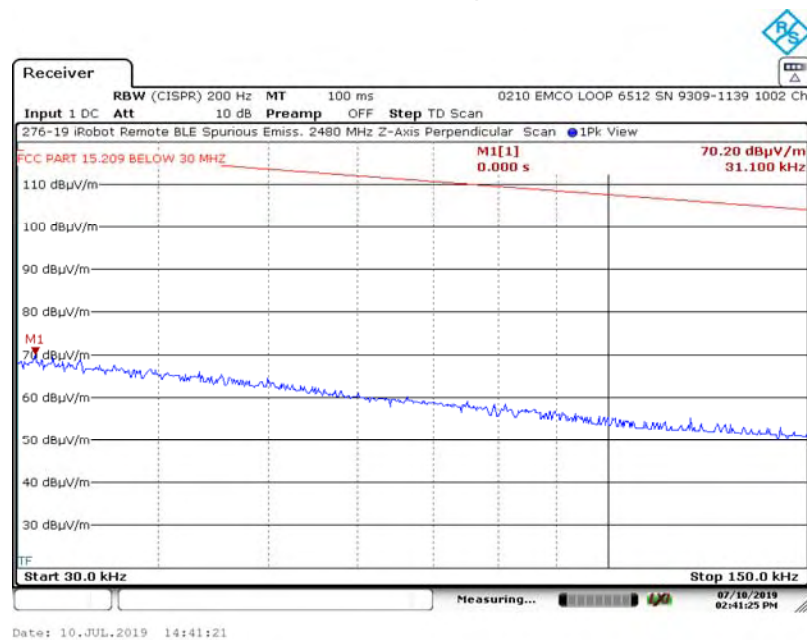

Appendix A - Transmitter Spurious Radiated Emissions (30 kHz to 25 GHz)

A1. Spurious Radiated Emissions (30 kHz – 150 kHz) Test Results

A1.3. Channel 39, 2480 MHz

A1.3.9. Measurement Results: Z-Axis, Ground Parallel Antenna

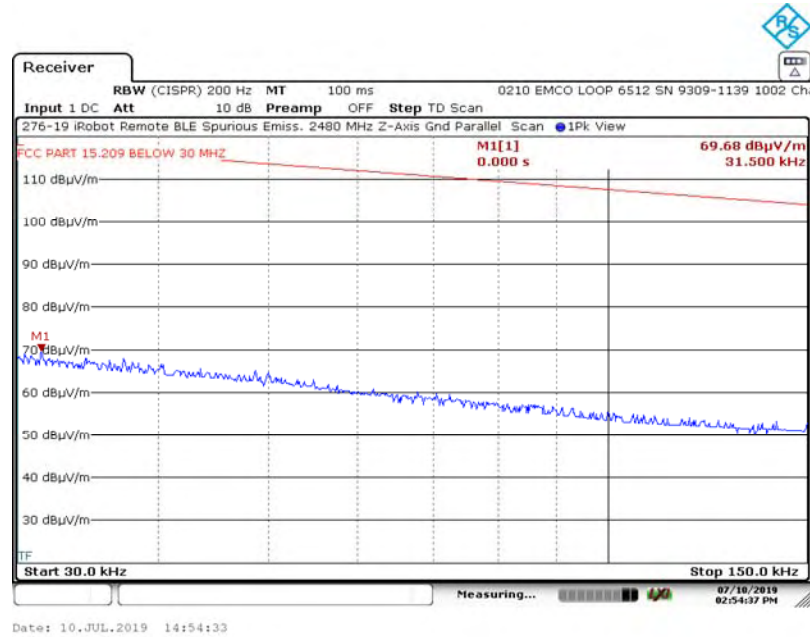

Appendix A - Transmitter Spurious Radiated Emissions (30 kHz to 25 GHz)

A2. Spurious Radiated Emissions (150 kHz – 30 MHz) Test Results

A2.1. Channel 37, 2402 MHz

A2.1.1. Measurement Results: X-Axis, Parallel Antenna

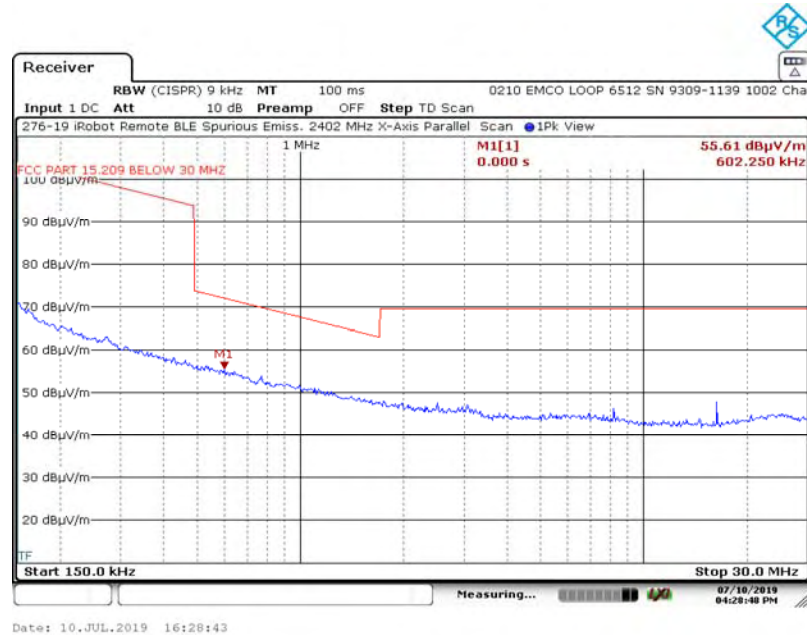

A2.1.2. Measurement Results: X-Axis, Perpendicular Antenna

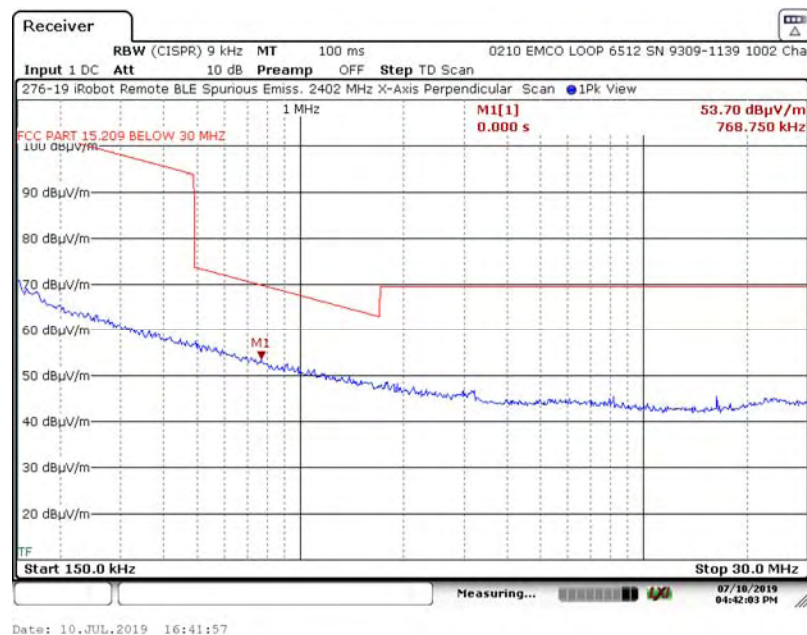

Appendix A - Transmitter Spurious Radiated Emissions (30 kHz to 25 GHz)

A2. Spurious Radiated Emissions (150 kHz – 30 MHz) Test Results

A2.1. Channel 37, 2402 MHz

A2.1.3. Measurement Results: X-Axis, Ground-Parallel Antenna

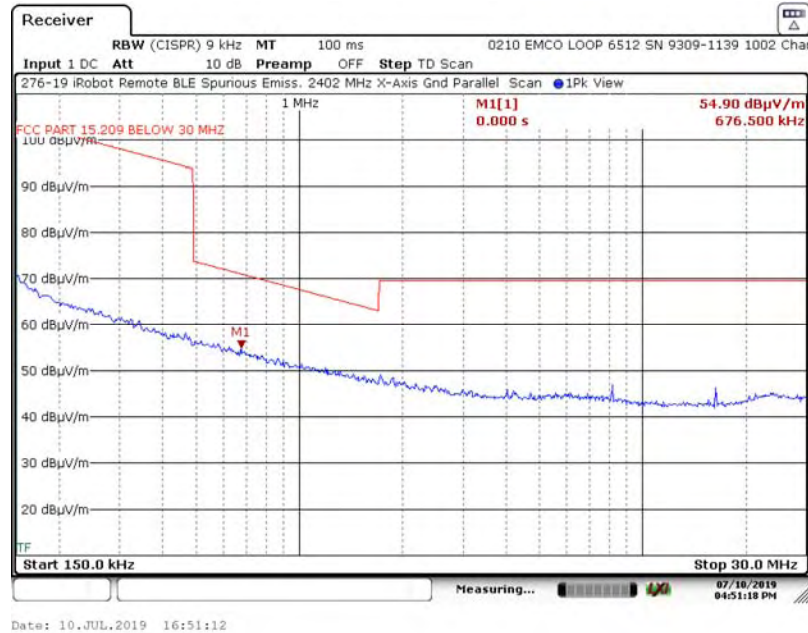

A2.1.4. Measurement Results: Y-Axis, Parallel Antenna

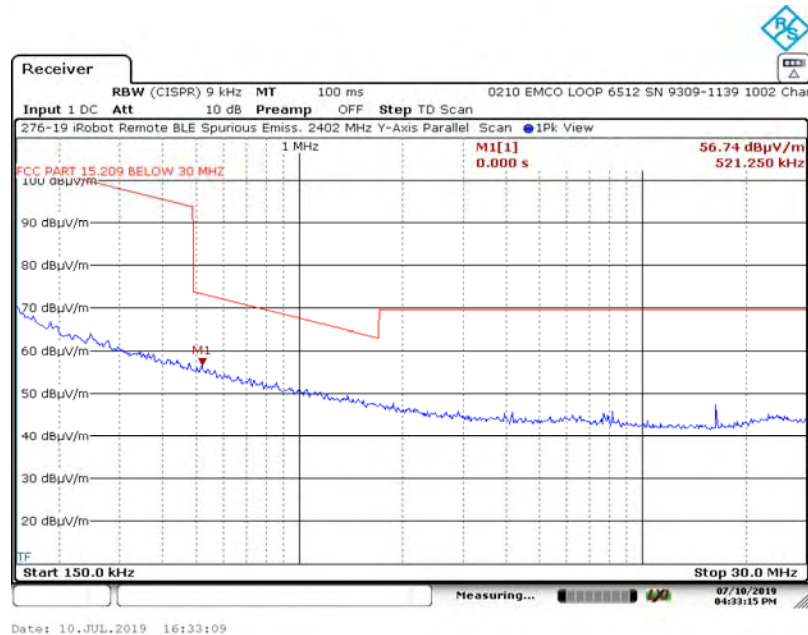

Appendix A - Transmitter Spurious Radiated Emissions (30 kHz to 25 GHz)

A2. Spurious Radiated Emissions (150 kHz – 30 MHz) Test Results

A2.1. Channel 37, 2402 MHz

A2.1.5. Measurement Results: Y-Axis, Perpendicular Antenna

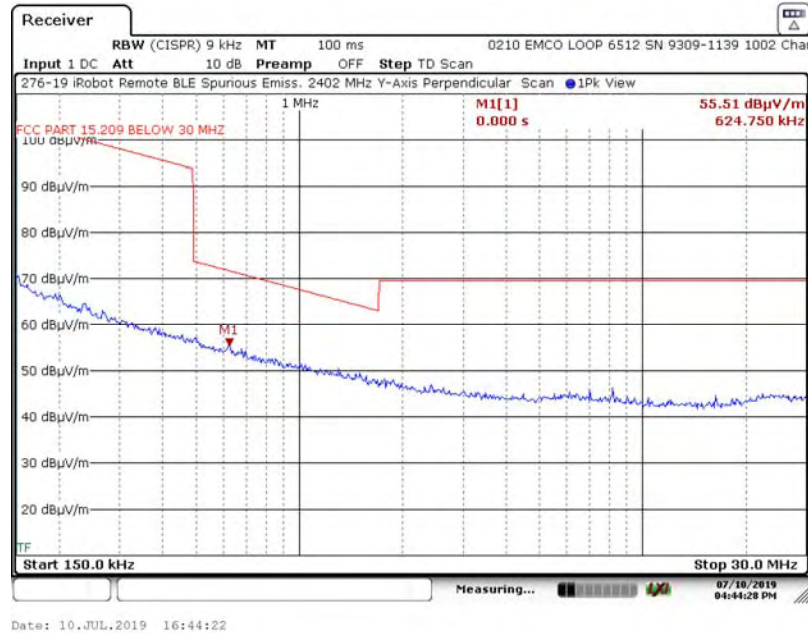

A2.1.6. Measurement Results: Y-Axis, Ground-Parallel Antenna

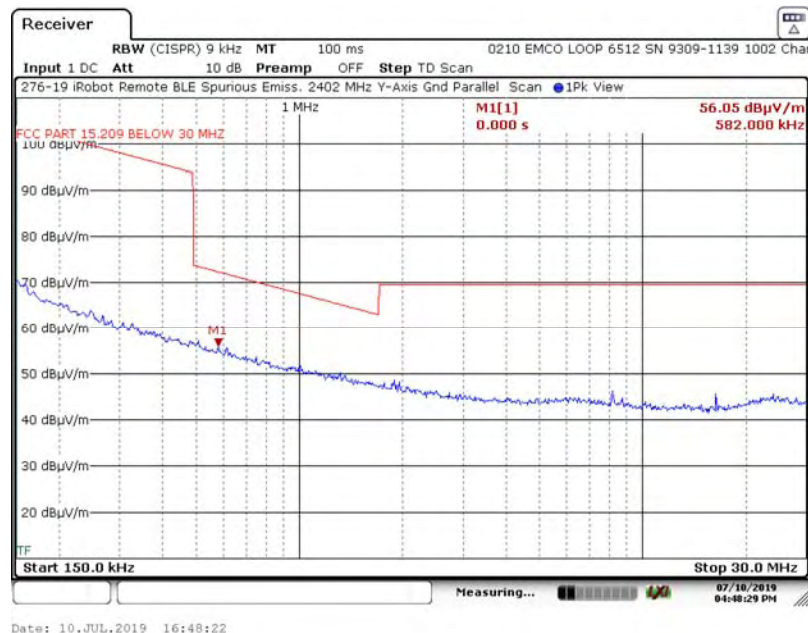

Appendix A - Transmitter Spurious Radiated Emissions (30 kHz to 25 GHz)

A2. Spurious Radiated Emissions (150 kHz – 30 MHz) Test Results

A2.1. Channel 37, 2402 MHz

A2.1.7. Measurement Results: Z-Axis, Parallel Antenna

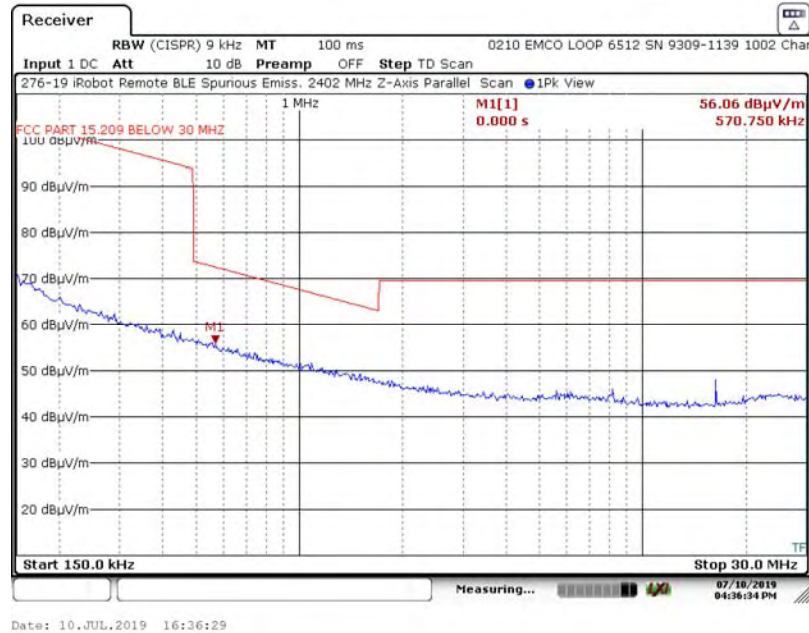

A2.1.8. Measurement Results: Z-Axis, Perpendicular Antenna

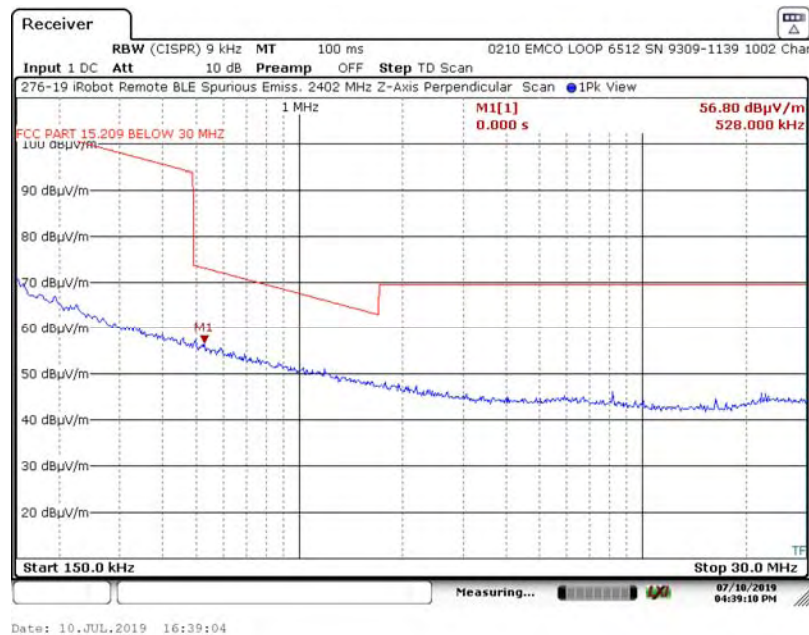

Appendix A - Transmitter Spurious Radiated Emissions (30 kHz to 25 GHz)

A2. Spurious Radiated Emissions (150 kHz – 30 MHz) Test Results

A2.1. Channel 37, 2402 MHz

A2.1.9. Measurement Results: Z-Axis, Ground Parallel Antenna

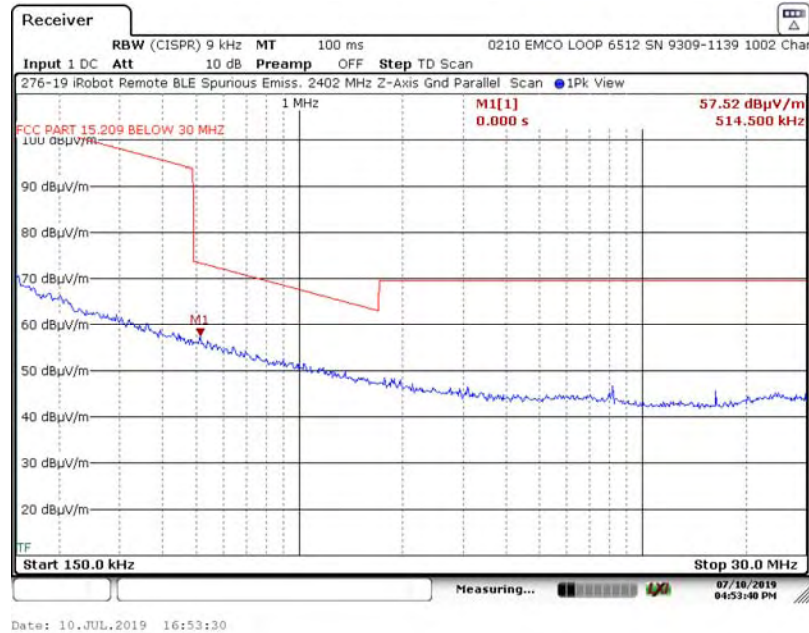

Appendix A - Transmitter Spurious Radiated Emissions (30 kHz to 25 GHz)

A2. Spurious Radiated Emissions (150 kHz – 30 MHz) Test Results

A2.2. Channel 17, 2440 MHz

A2.2.1. Measurement Results: X-Axis, Parallel Antenna

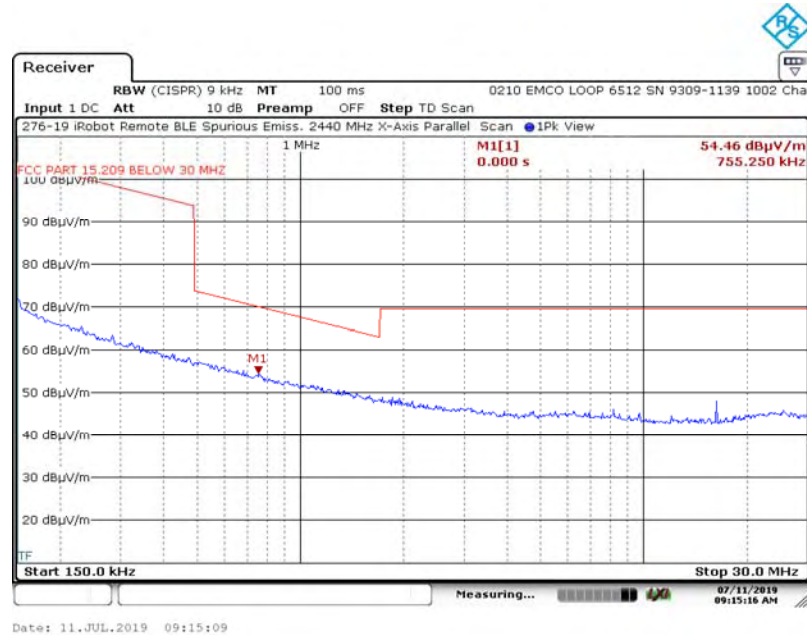

A2.2.2. Measurement Results: X-Axis, Perpendicular Antenna

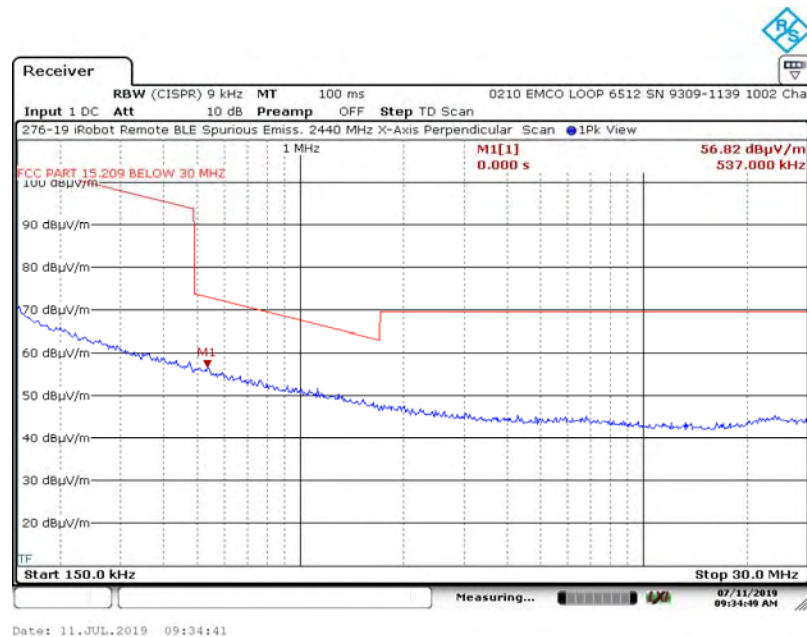

Appendix A - Transmitter Spurious Radiated Emissions (30 kHz to 25 GHz)

A2. Spurious Radiated Emissions (150 kHz – 30 MHz) Test Results

A2.2. Channel 17, 2440 MHz

A2.2.3. Measurement Results: X-Axis, Ground-Parallel Antenna

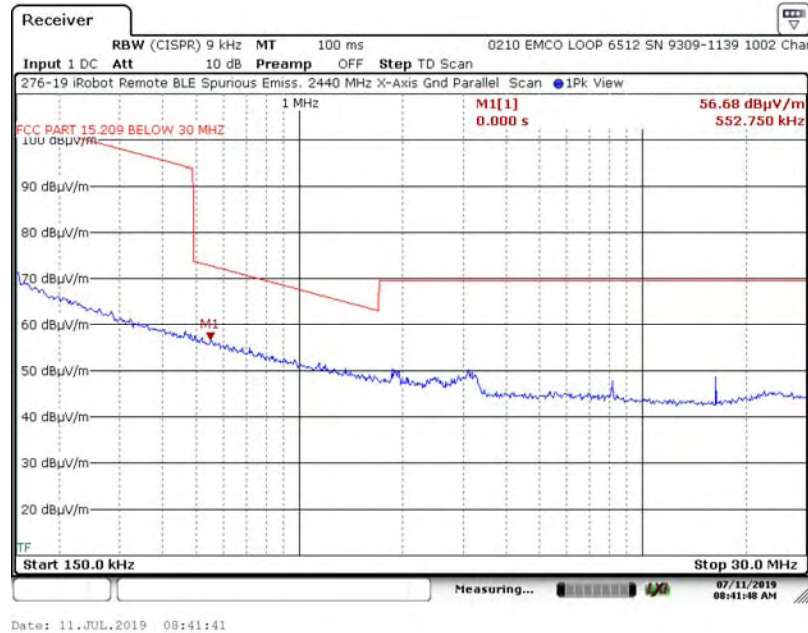

A2.2.4. Measurement Results: Y-Axis, Parallel Antenna

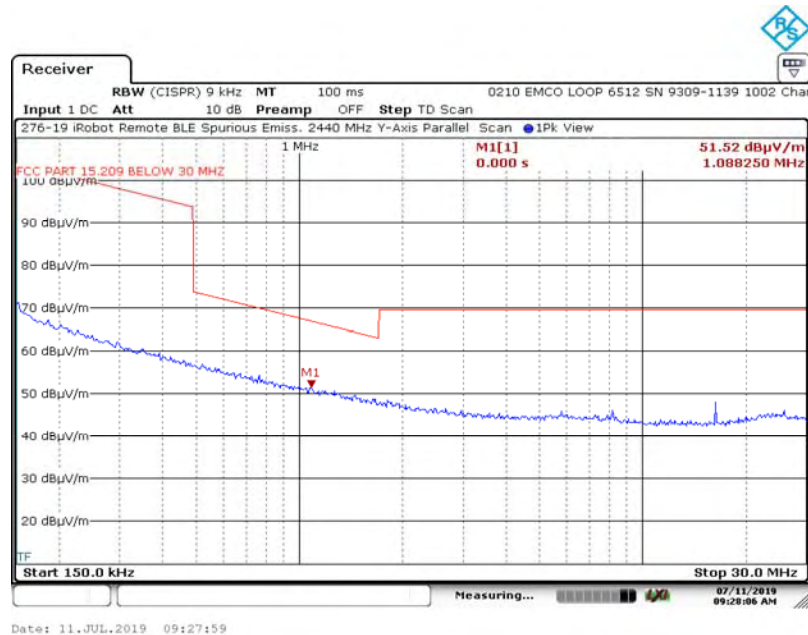

Appendix A - Transmitter Spurious Radiated Emissions (30 kHz to 25 GHz)

A2. Spurious Radiated Emissions (150 kHz – 30 MHz) Test Results

A2.2. Channel 17, 2440 MHz

A2.2.5. Measurement Results: Y-Axis, Perpendicular Antenna

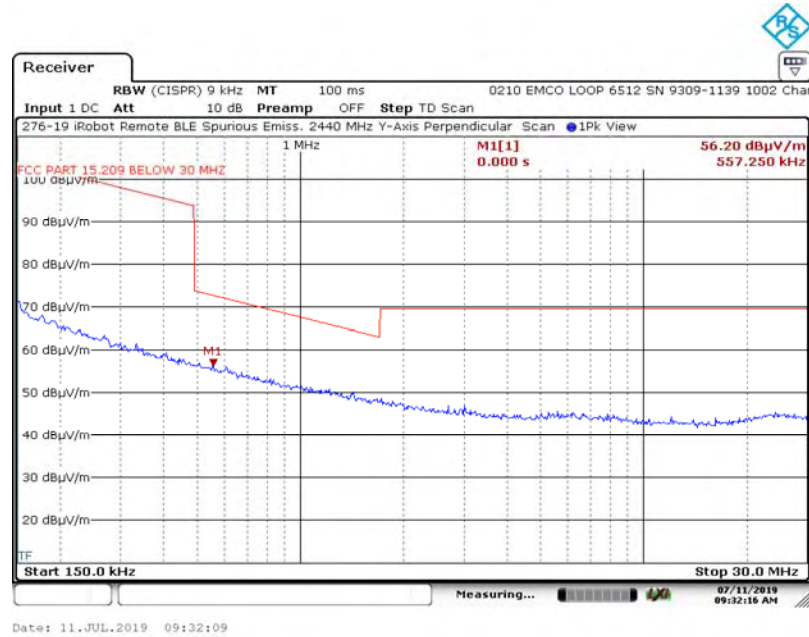

A2.2.6. Measurement Results: Y-Axis, Ground-Parallel Antenna

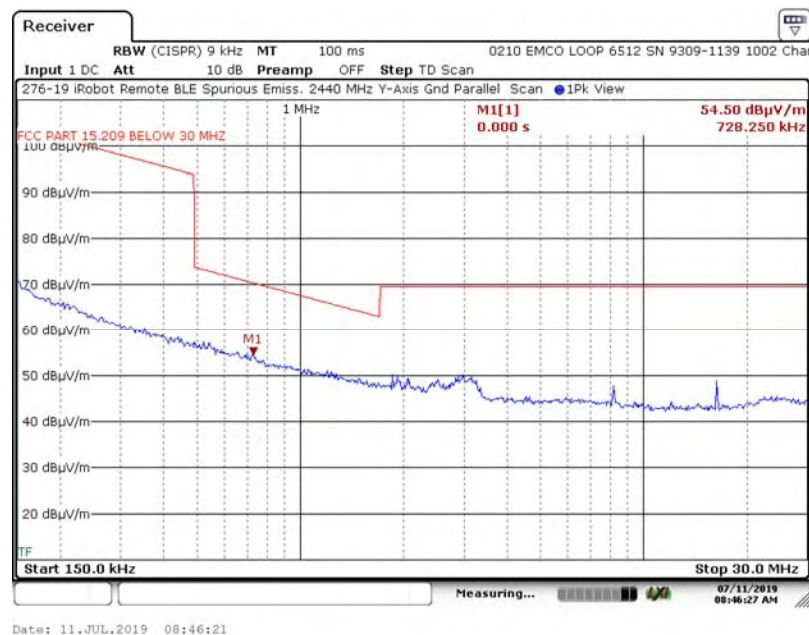

Appendix A - Transmitter Spurious Radiated Emissions (30 kHz to 25 GHz)

A2. Spurious Radiated Emissions (150 kHz – 30 MHz) Test Results

A2.2. Channel 17, 2440 MHz

A2.2.7. Measurement Results: Z-Axis, Parallel Antenna

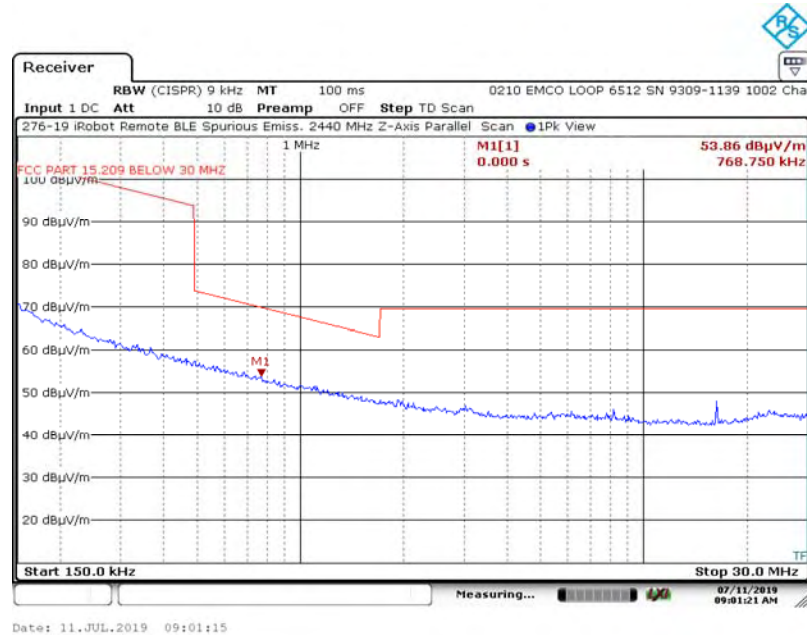

A2.2.8. Measurement Results: Z-Axis, Perpendicular Antenna

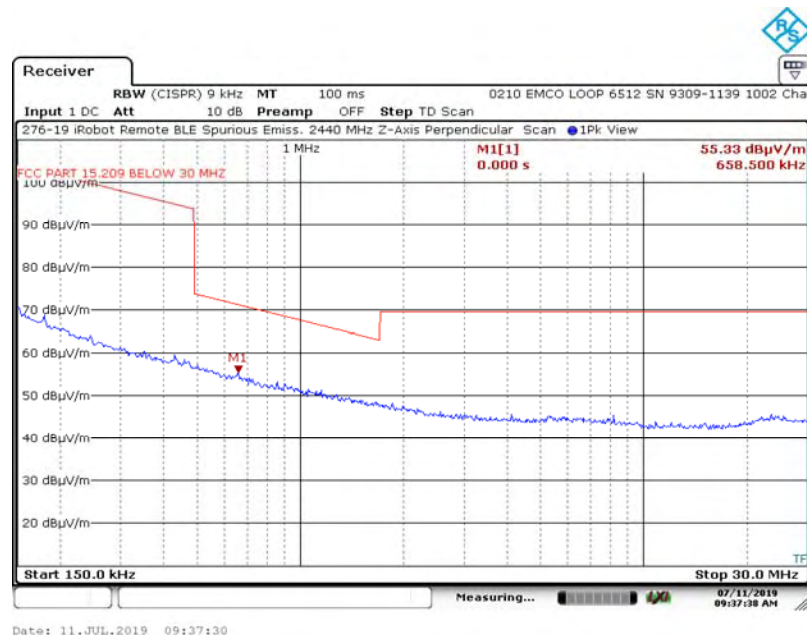

Appendix A - Transmitter Spurious Radiated Emissions (30 kHz to 25 GHz)

A2. Spurious Radiated Emissions (150 kHz – 30 MHz) Test Results

A2.2. Channel 17, 2440 MHz

A2.2.9. Measurement Results: Z-Axis, Ground Parallel Antenna

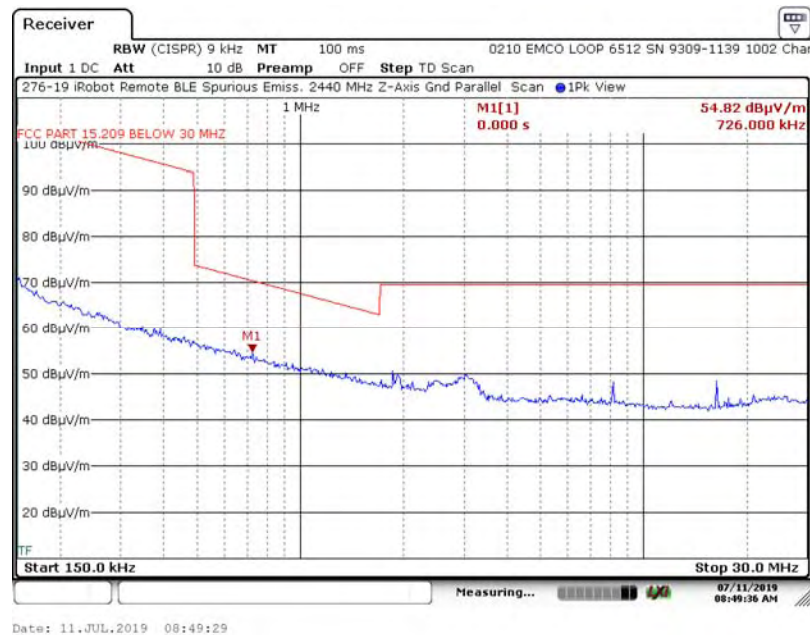

Appendix A - Transmitter Spurious Radiated Emissions (30 kHz to 25 GHz)

A2. Spurious Radiated Emissions (150 kHz – 30 MHz) Test Results

A2.3. Channel 39, 2480 MHz

A2.3.1. Measurement Results: X-Axis, Parallel Antenna

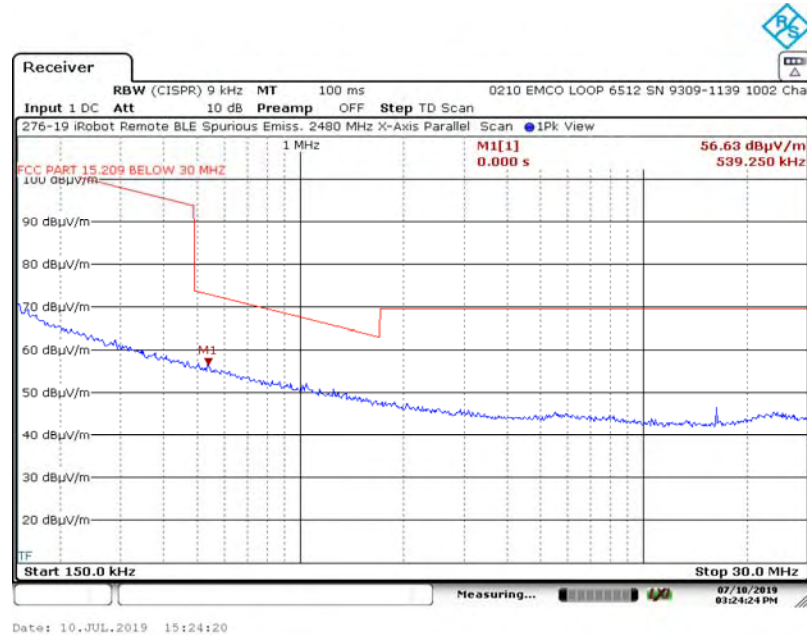

A2.3.2. Measurement Results: X-Axis, Perpendicular Antenna

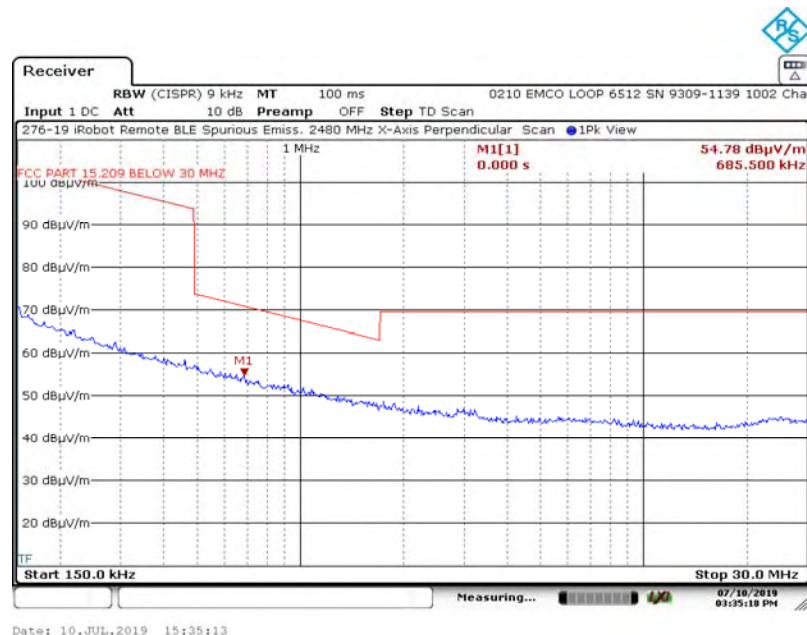

Appendix A - Transmitter Spurious Radiated Emissions (30 kHz to 25 GHz)

A2. Spurious Radiated Emissions (150 kHz – 30 MHz) Test Results

A2.3. Channel 39, 2480 MHz

A2.3.3. Measurement Results: X-Axis, Ground-Parallel Antenna

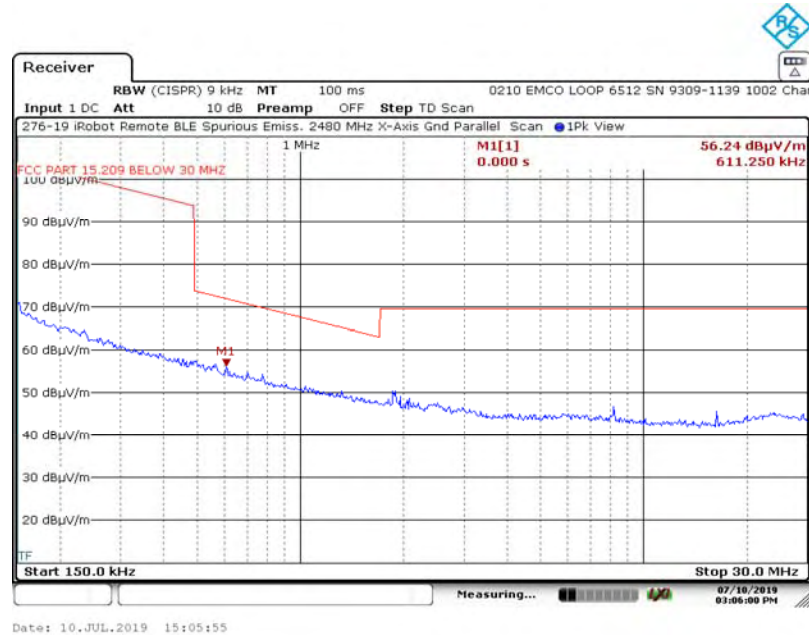

A2.3.4. Measurement Results: Y-Axis, Parallel Antenna

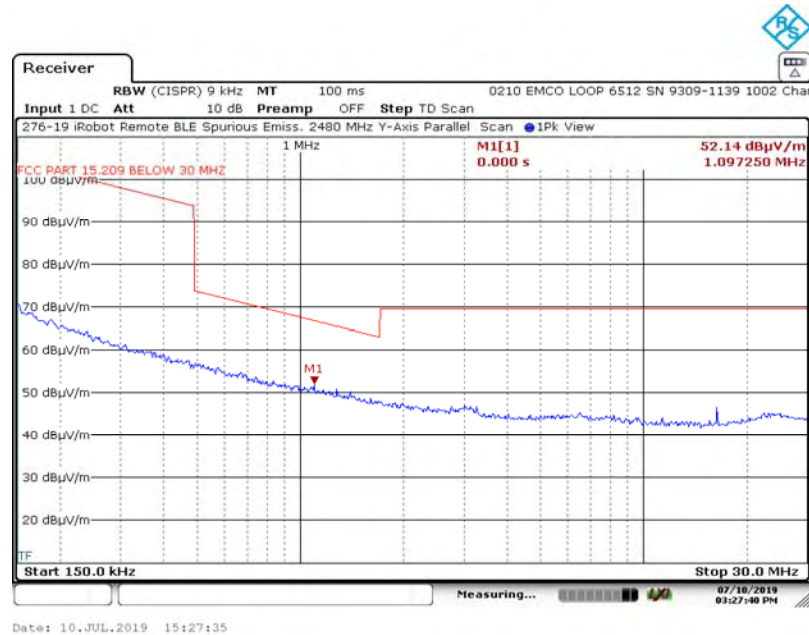

Appendix A - Transmitter Spurious Radiated Emissions (30 kHz to 25 GHz)

A2. Spurious Radiated Emissions (150 kHz – 30 MHz) Test Results

A2.3. Channel 39, 2480 MHz

A2.3.5. Measurement Results: Y-Axis, Perpendicular Antenna

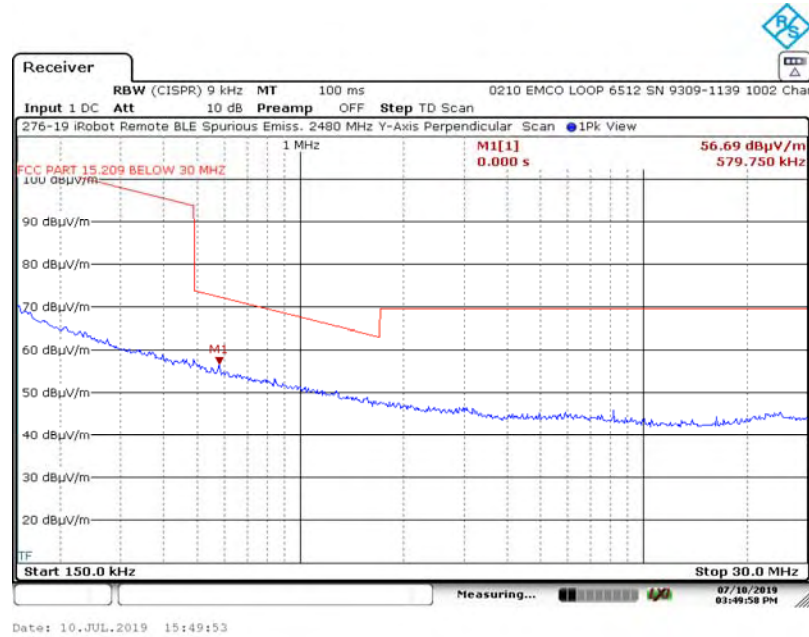

A2.3.6. Measurement Results: Y-Axis, Ground-Parallel Antenna

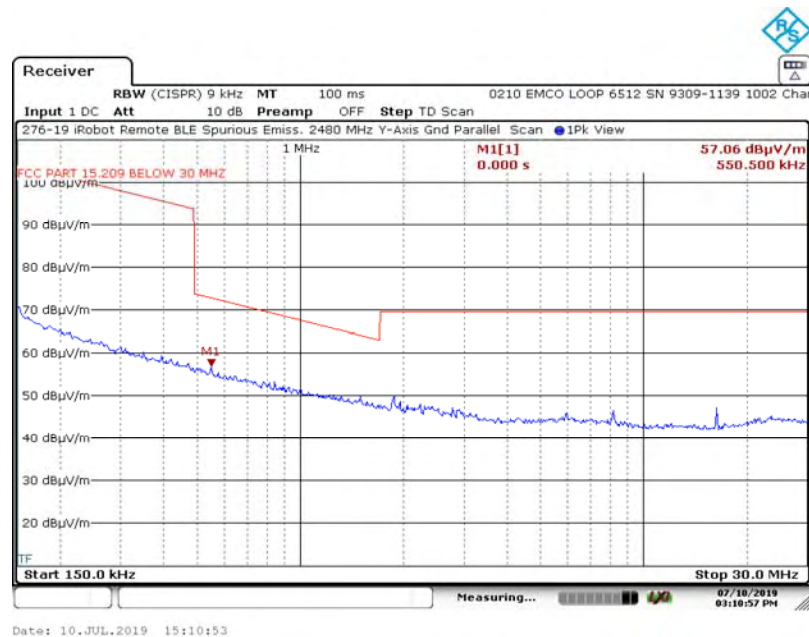

Appendix A - Transmitter Spurious Radiated Emissions (30 kHz to 25 GHz)

A2. Spurious Radiated Emissions (150 kHz – 30 MHz) Test Results

A2.3. Channel 39, 2480 MHz

A2.3.7. Measurement Results: Z-Axis, Parallel Antenna

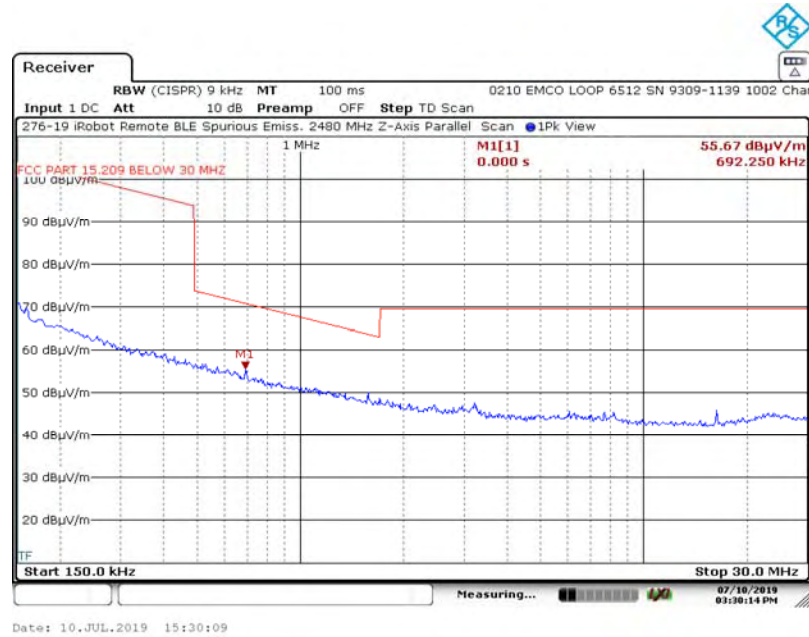

A2.3.8. Measurement Results: Z-Axis, Perpendicular Antenna

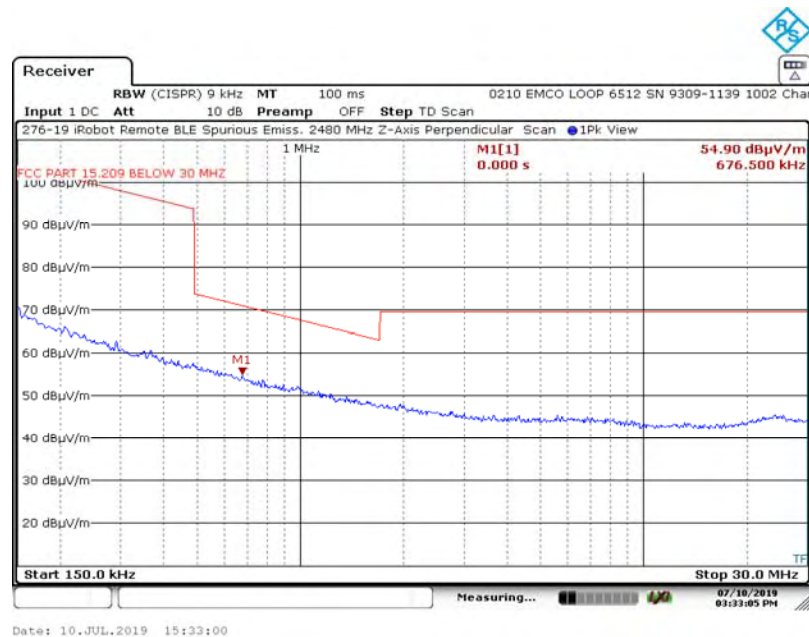

Appendix A - Transmitter Spurious Radiated Emissions (30 kHz to 25 GHz)

A2. Spurious Radiated Emissions (150 kHz – 30 MHz) Test Results

A2.3. Channel 39, 2480 MHz

A2.3.9. Measurement Results: Z-Axis, Ground Parallel Antenna

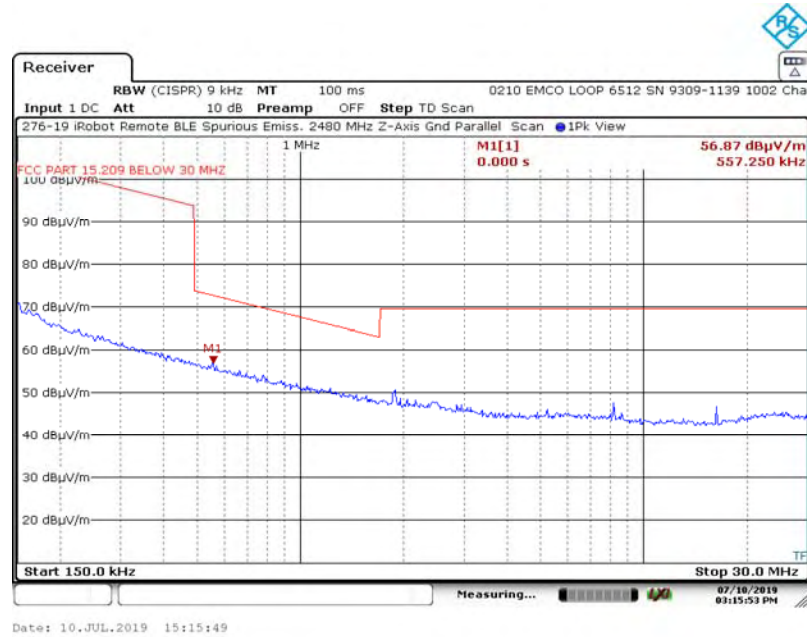

Appendix A - Transmitter Spurious Radiated Emissions (30 kHz to 25 GHz)

A3. Spurious Radiated Emissions (30 MHz – 1 GHz) Test Results

A3.1. Channel 37, 2402 MHz

A3.1.1. Measurement Results: X-Axis, Horizontal Antenna

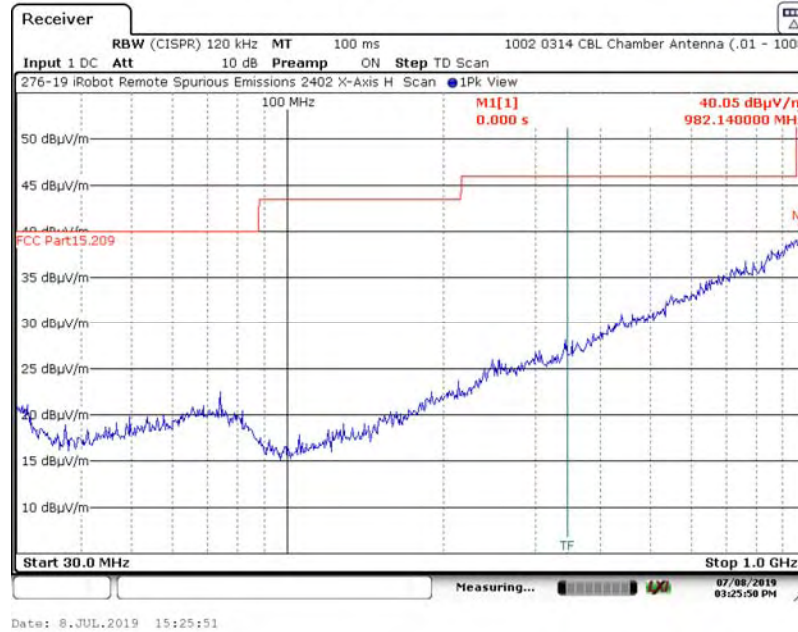

A3.1.2. Measurement Results: X-Axis, Vertical Antenna

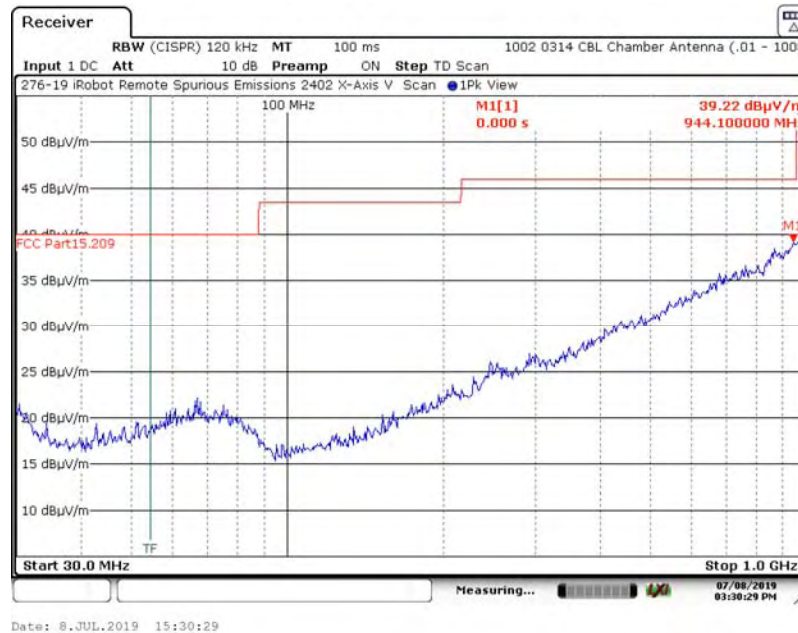

Appendix A - Transmitter Spurious Radiated Emissions (30 kHz to 25 GHz)

A3. Spurious Radiated Emissions (30 MHz – 1 GHz) Test Results

A3.1. Channel 37, 2402 MHz

A3.1.3. Measurement Results: Y-Axis, Horizontal Antenna

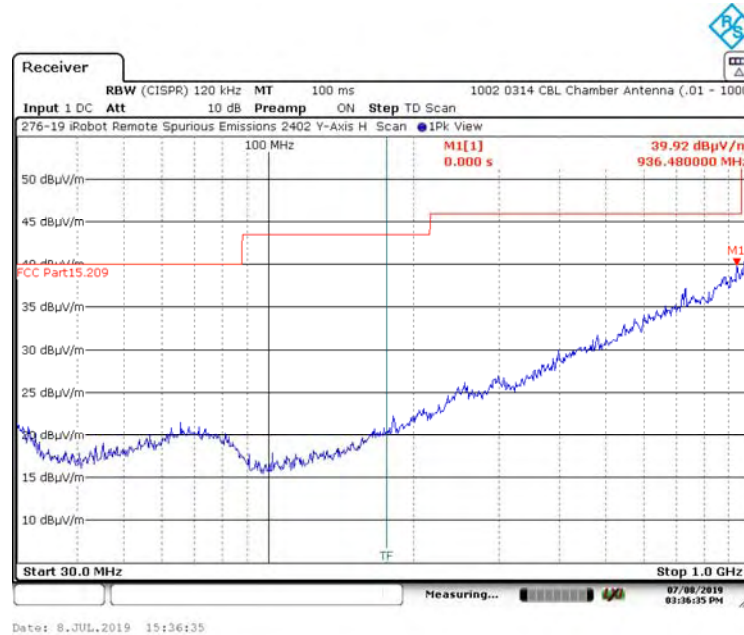

A3.1.4. Measurement Results: Y-Axis, Vertical Antenna

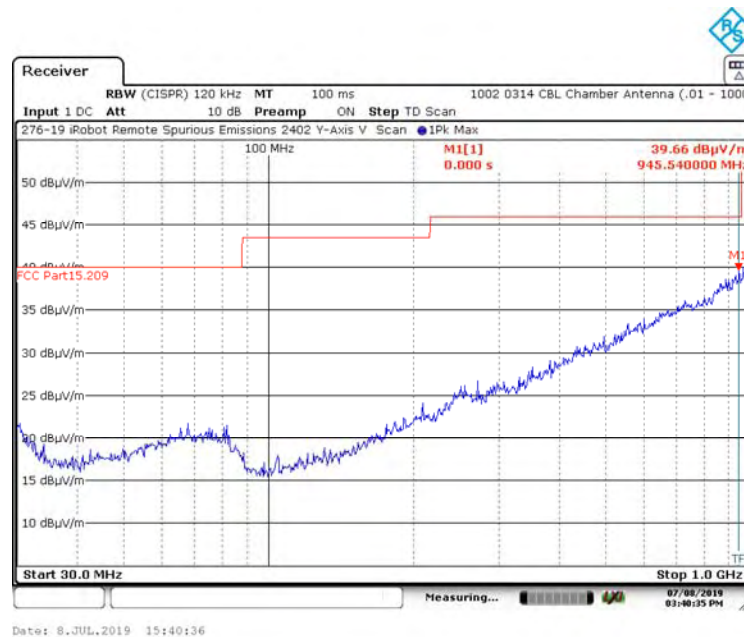

Appendix A - Transmitter Spurious Radiated Emissions (30 kHz to 25 GHz)

A3. Spurious Radiated Emissions (30 MHz – 1 GHz) Test Results

A3.1. Channel 37, 2402 MHz

A3.1.5. Measurement Results: Z-Axis, Horizontal Antenna

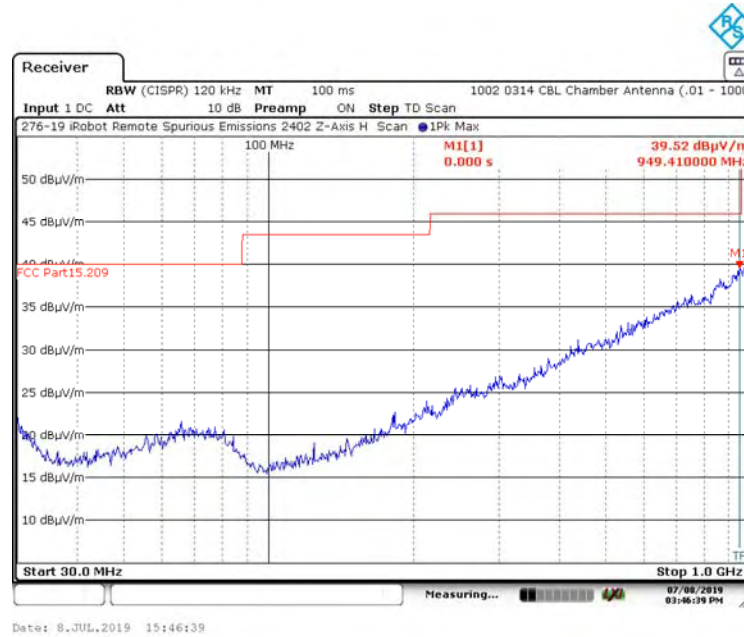

A3.1.6. Measurement Results: Z-Axis, Vertical Antenna

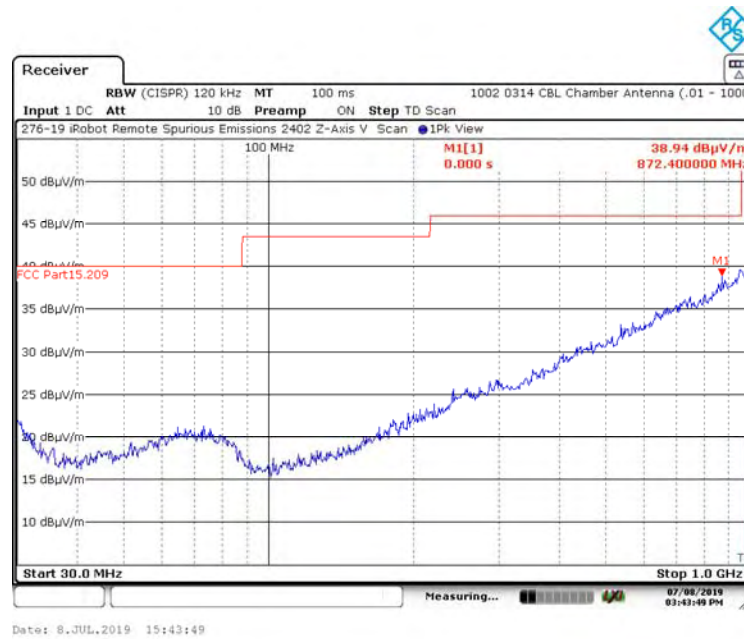

Appendix A - Transmitter Spurious Radiated Emissions (30 kHz to 25 GHz)

A3. Spurious Radiated Emissions (30 MHz – 1 GHz) Test Results

A3.2. Channel 17, 2440 MHz

A3.2.1. Measurement Results: X-Axis, Horizontal Antenna

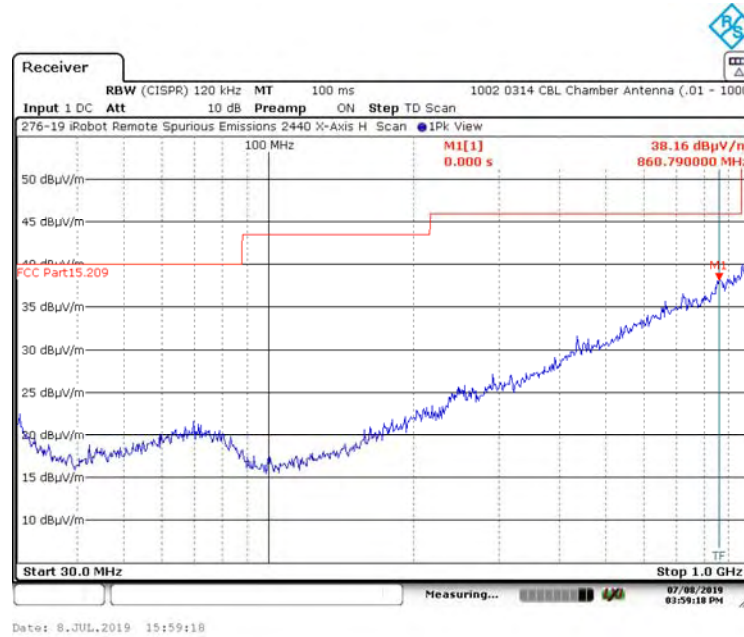

A3.2.2. Measurement Results: X-Axis, Vertical Antenna

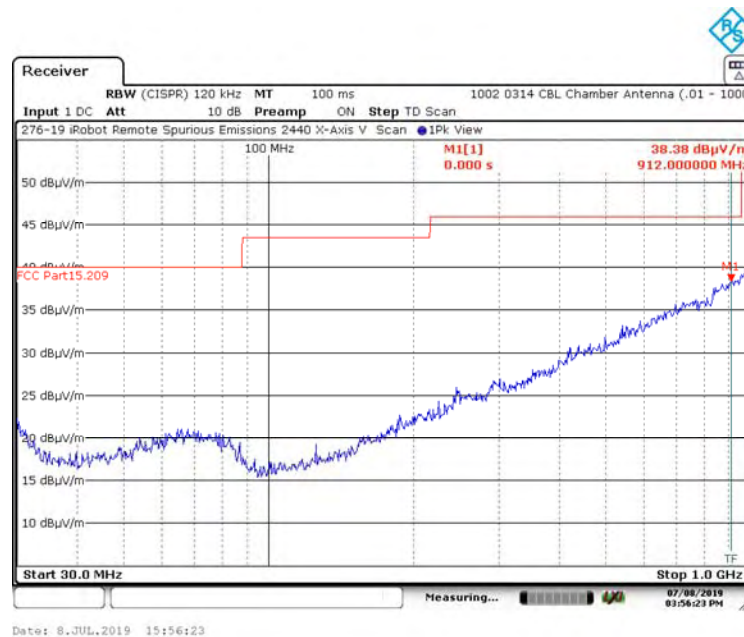

Appendix A - Transmitter Spurious Radiated Emissions (30 kHz to 25 GHz)

A3. Spurious Radiated Emissions (30 MHz – 1 GHz) Test Results

A3.2. Channel 17, 2440 MHz

A3.2.3. Measurement Results: Y-Axis, Horizontal Antenna

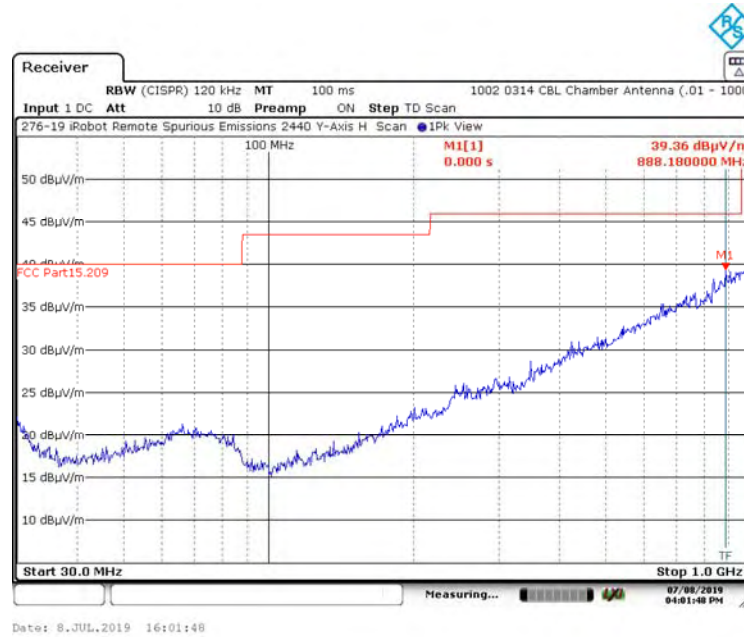

A3.2.4. Measurement Results: Y-Axis, Vertical Antenna

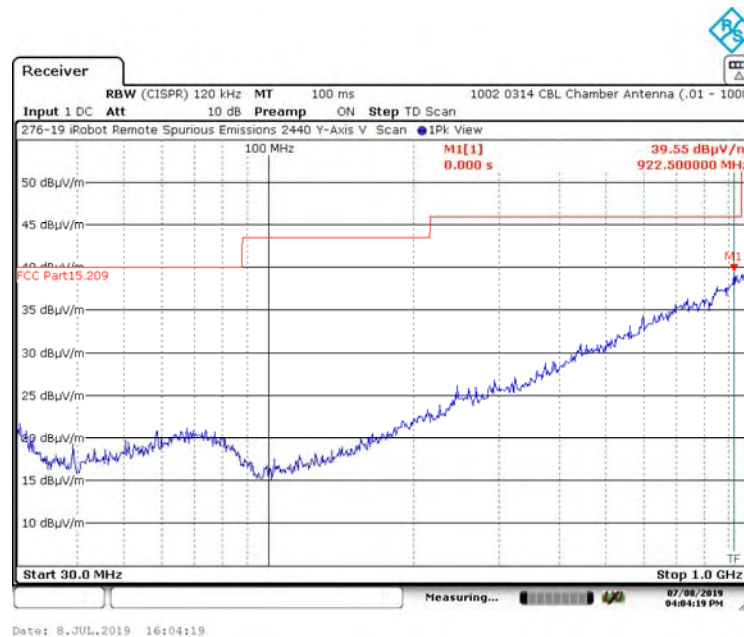

Appendix A - Transmitter Spurious Radiated Emissions (30 kHz to 25 GHz)

A3. Spurious Radiated Emissions (30 MHz – 1 GHz) Test Results

A3.2. Channel 17, 2440 MHz

A3.2.5. Measurement Results: Z-Axis, Horizontal Antenna

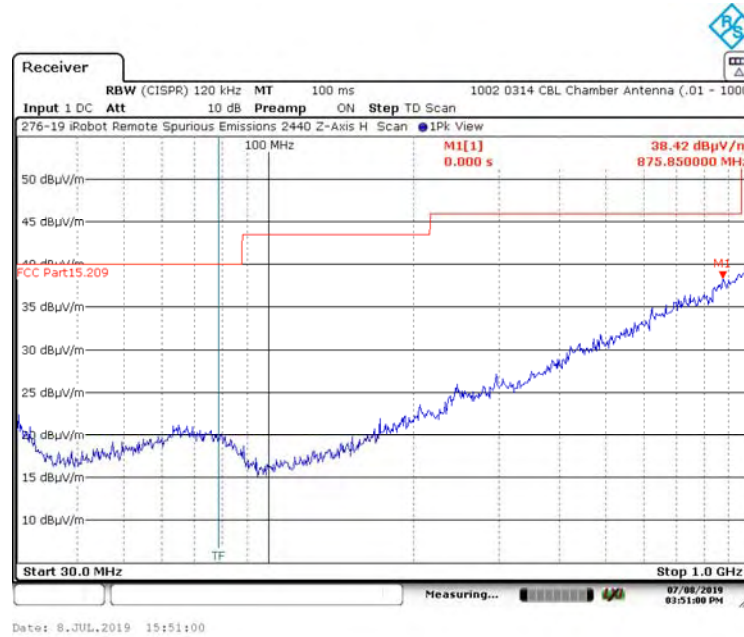

A3.2.6. Measurement Results: Z-Axis, Vertical Antenna

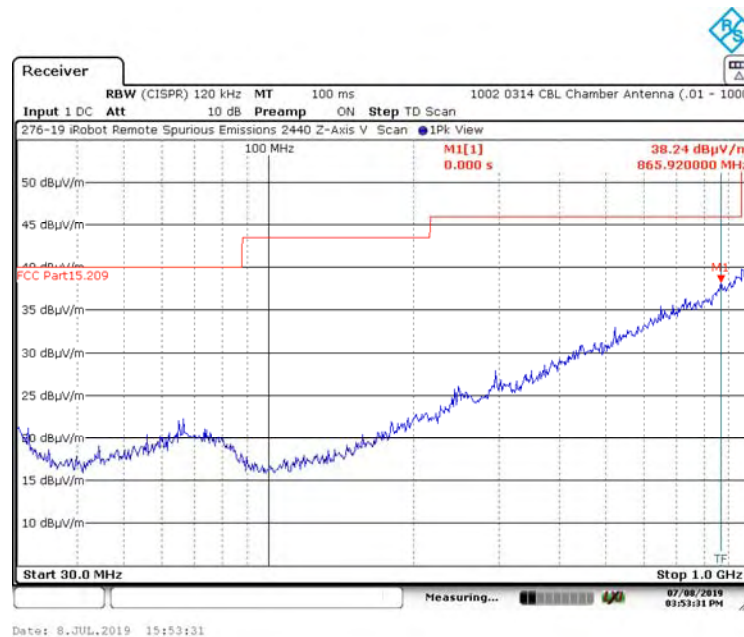

Appendix A - Transmitter Spurious Radiated Emissions (30 kHz to 25 GHz)

A3. Spurious Radiated Emissions (30 MHz – 1 GHz) Test Results

A3.3. Channel 39, 2480 MHz

A3.3.1. Measurement Results: X-Axis, Horizontal Antenna

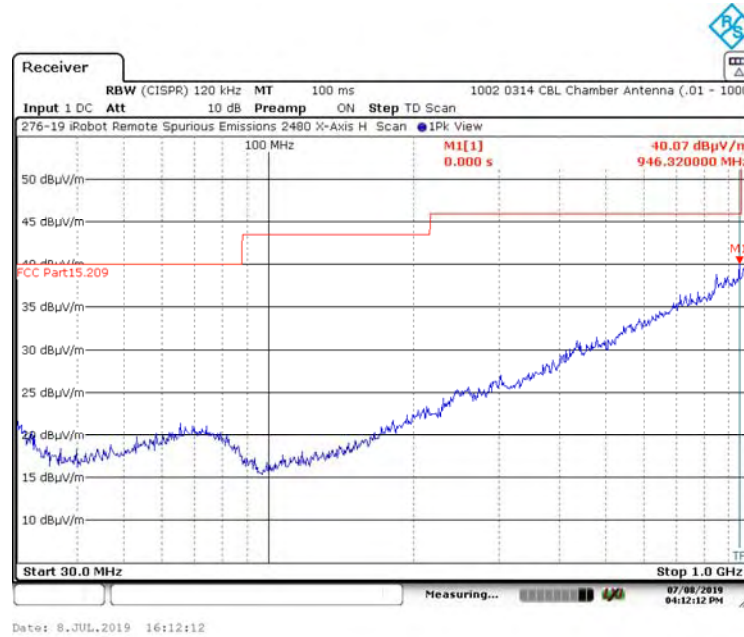

A3.3.2. Measurement Results: X-Axis, Vertical Antenna

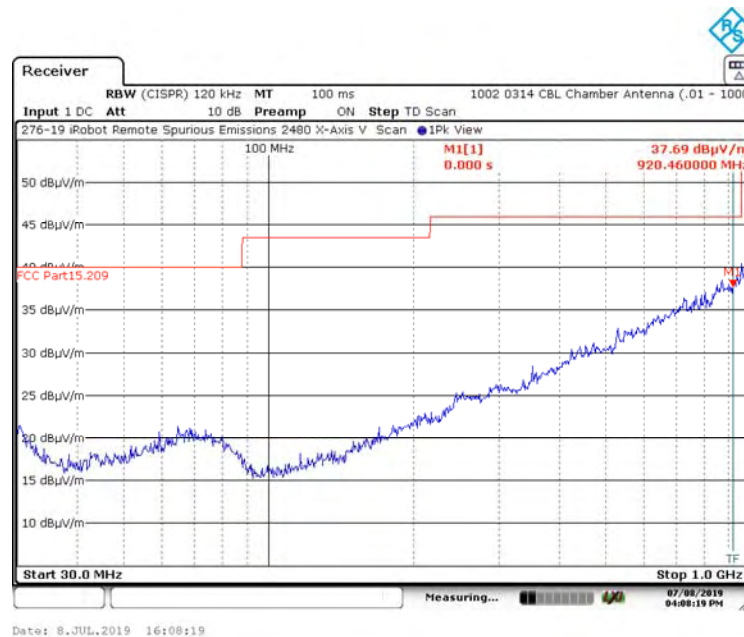

Appendix A - Transmitter Spurious Radiated Emissions (30 kHz to 25 GHz)

A3. Spurious Radiated Emissions (30 MHz – 1 GHz) Test Results

A3.3. Channel 39, 2480 MHz

A3.3.3. Measurement Results: Y-Axis, Horizontal Antenna

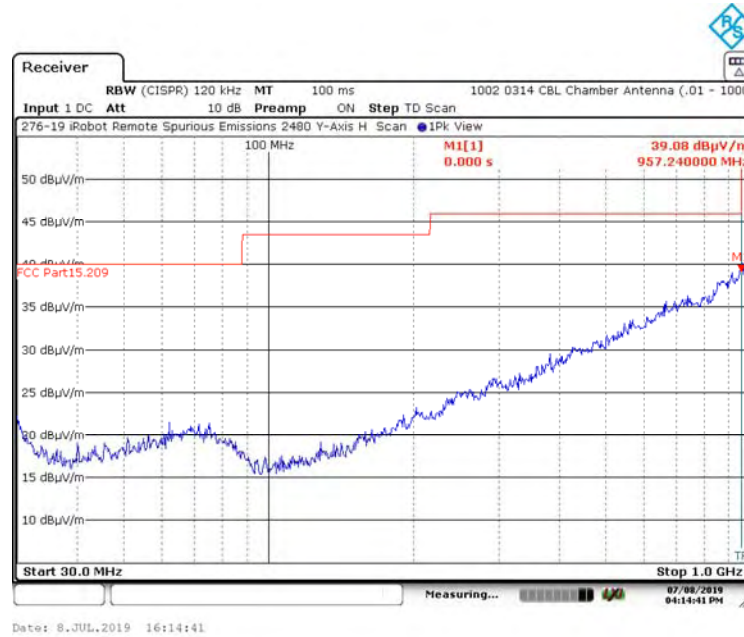

A3.3.4. Measurement Results: Y-Axis, Vertical Antenna

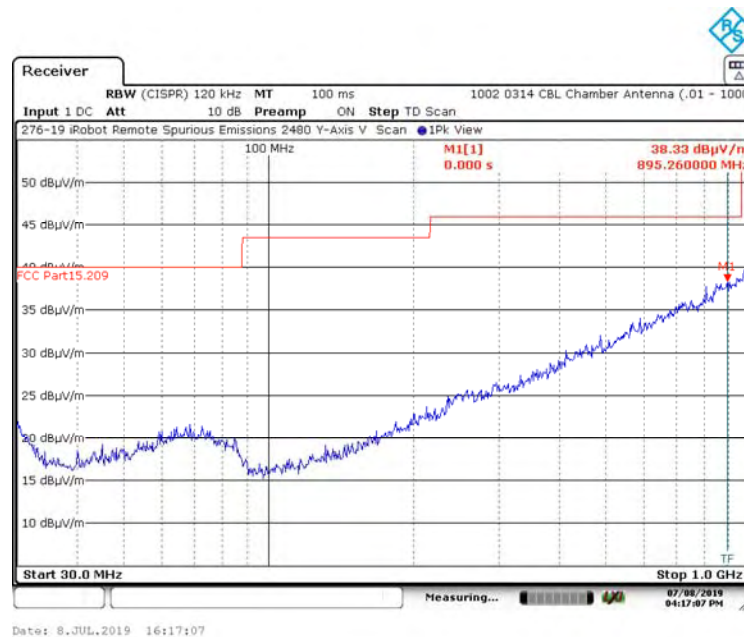

Appendix A - Transmitter Spurious Radiated Emissions (30 kHz to 25 GHz)

A3. Spurious Radiated Emissions (30 MHz – 1 GHz) Test Results

A3.3. Channel 39, 2480 MHz

A3.3.5. Measurement Results: Z-Axis, Horizontal Antenna

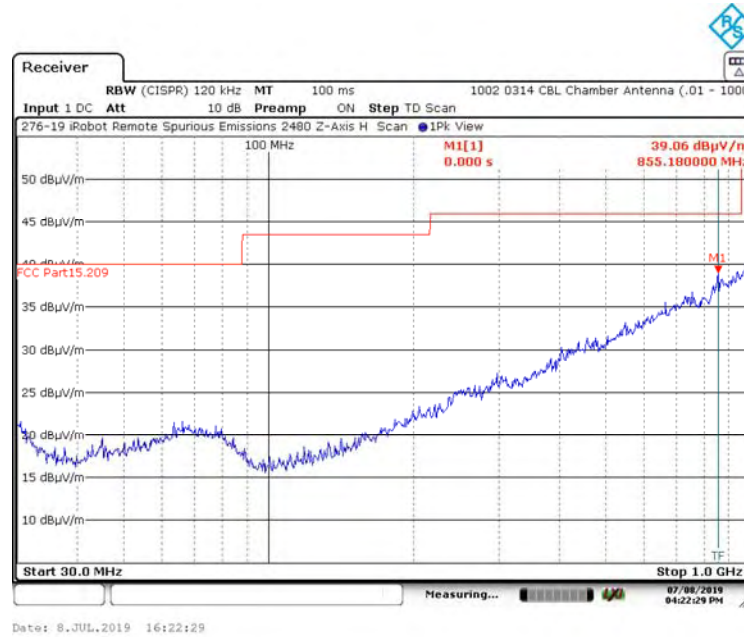

A3.3.6. Measurement Results: Z-Axis, Vertical Antenna

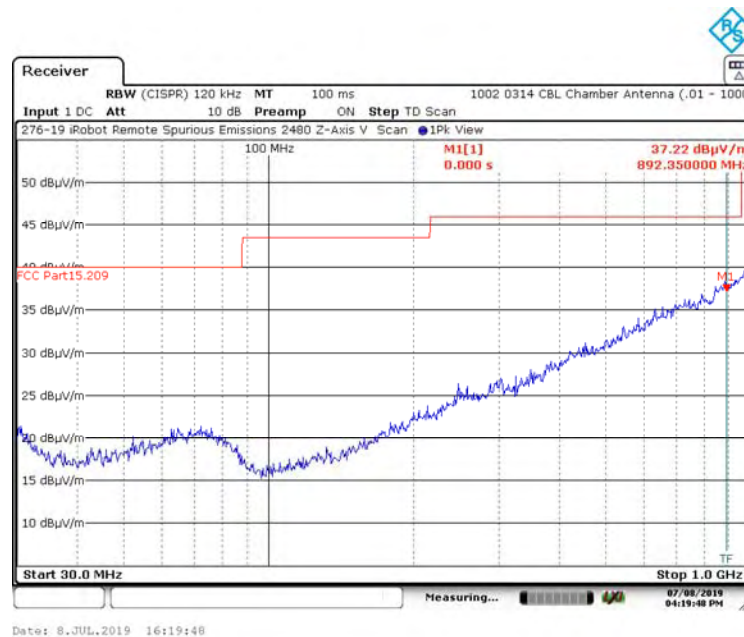

Appendix A - Transmitter Spurious Radiated Emissions (30 kHz to 25 GHz)

A4. Spurious Radiated Emissions (1 GHz – 10 GHz) Test Results

A4.1. Channel 37, 2402 MHz

A4.1.1. Measurement Results: X-Axis, Horizontal Antenna

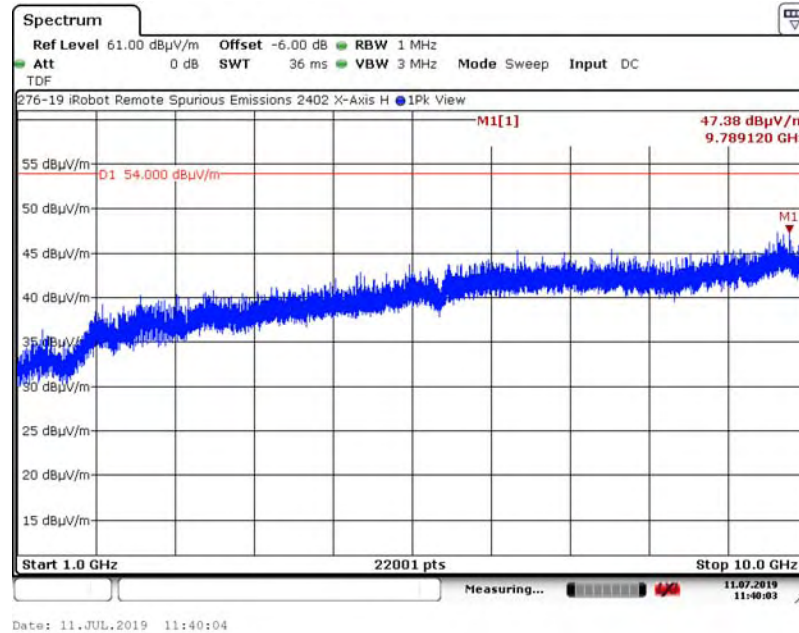

A4.1.2. Measurement Results: X-Axis, Vertical Antenna

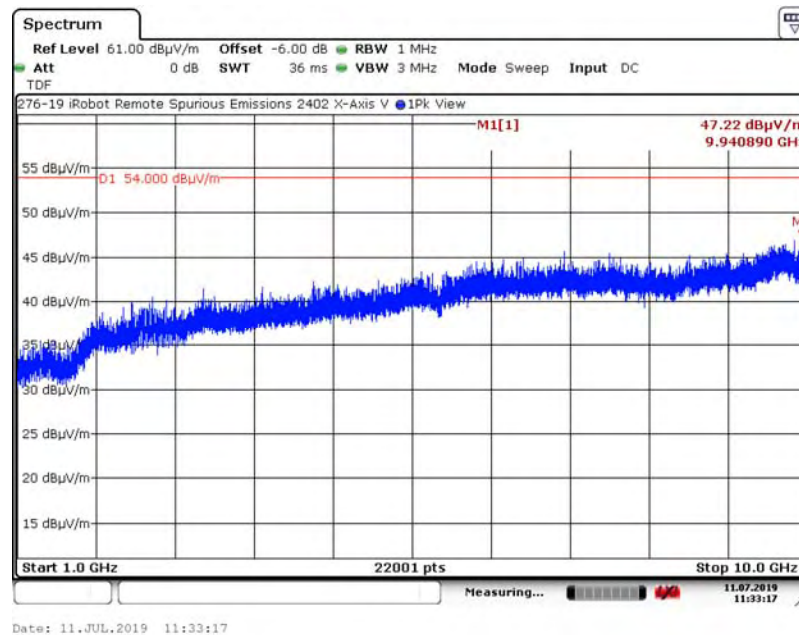

Appendix A - Transmitter Spurious Radiated Emissions (30 kHz to 25 GHz)

A4. Spurious Radiated Emissions (1 GHz – 10 GHz) Test Results

A4.1. Channel 37, 2402 MHz

A4.1.3. Measurement Results: Y-Axis, Horizontal Antenna

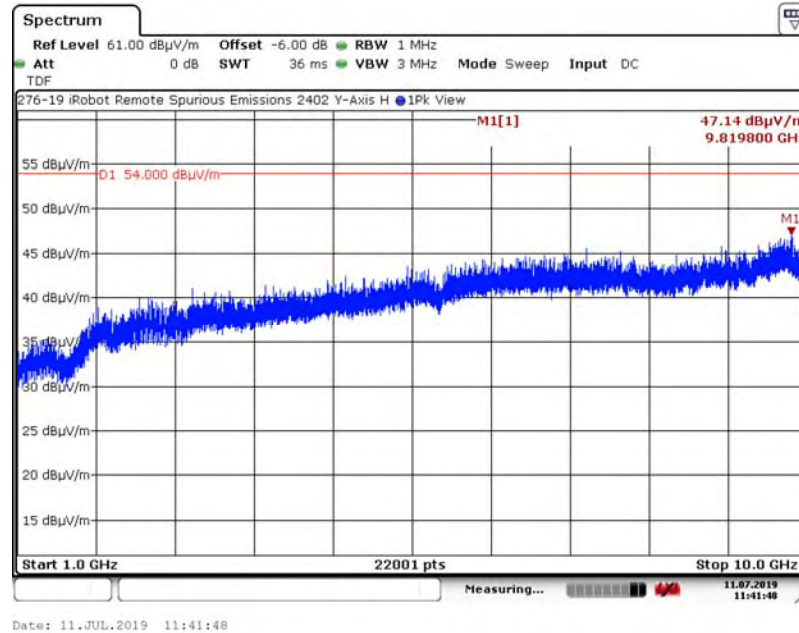

A4.1.4. Measurement Results: Y-Axis, Vertical Antenna

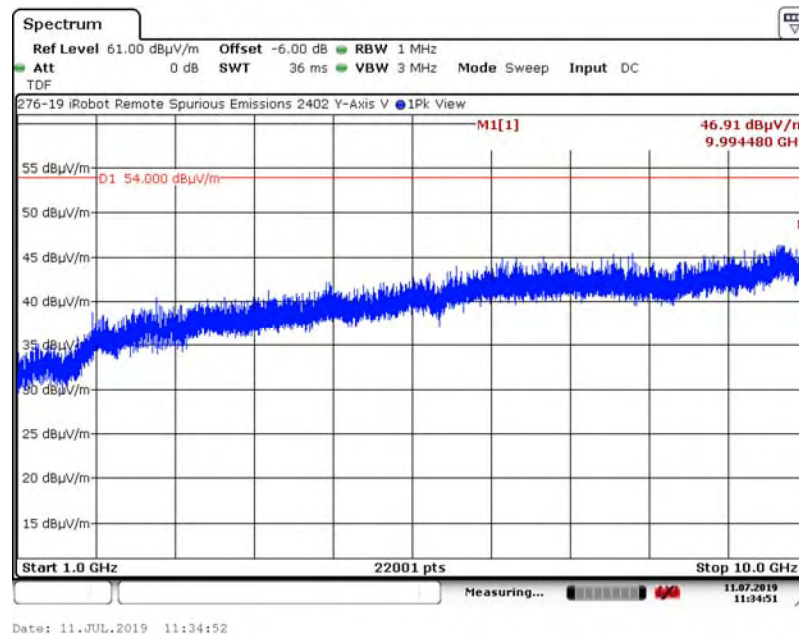

Appendix A - Transmitter Spurious Radiated Emissions (30 kHz to 25 GHz)

A4. Spurious Radiated Emissions (1 GHz – 10 GHz) Test Results

A4.1. Channel 37, 2402 MHz

A4.1.5. Measurement Results: Z-Axis, Horizontal Antenna

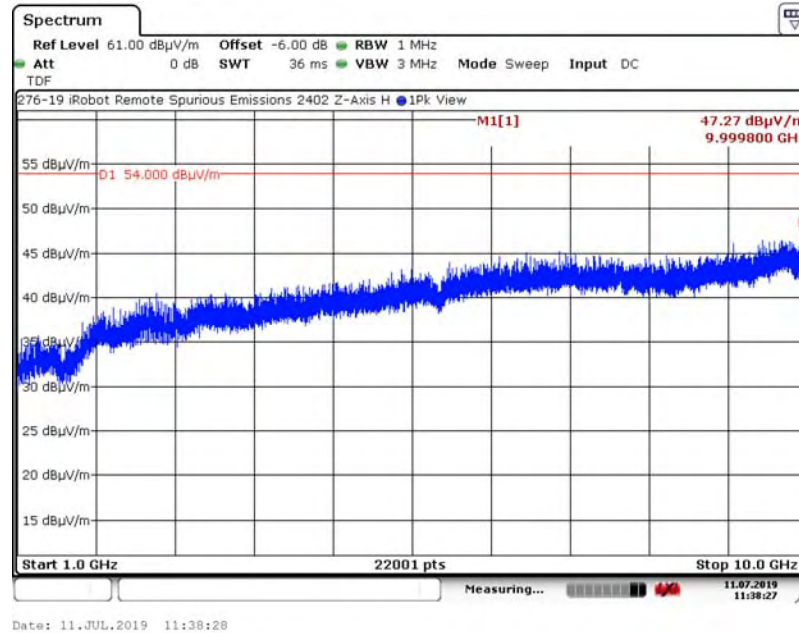

A4.1.6. Measurement Results: Z-Axis, Vertical Antenna

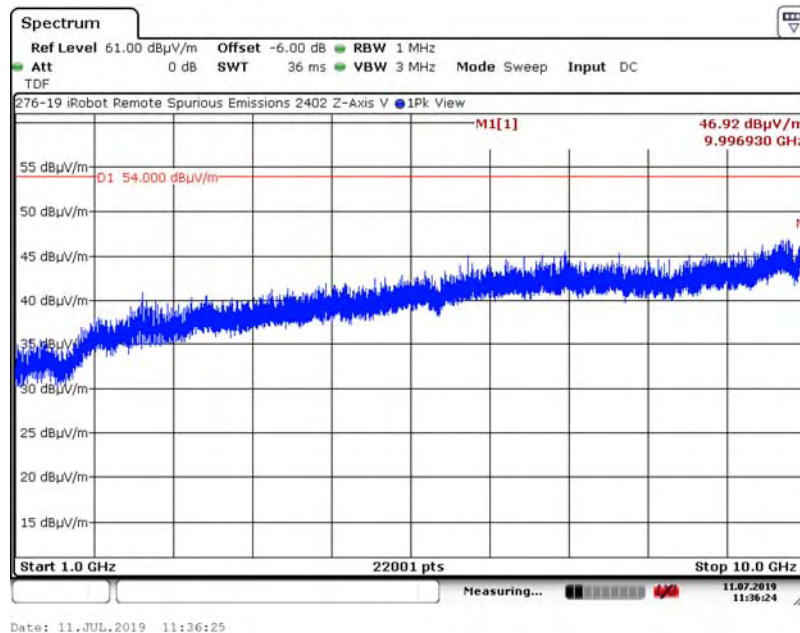

Appendix A - Transmitter Spurious Radiated Emissions (30 kHz to 25 GHz)

A4. Spurious Radiated Emissions (1 GHz – 10 GHz) Test Results

A4.2. Channel 17, 2440 MHz

A4.2.1. Measurement Results: X-Axis, Horizontal Antenna

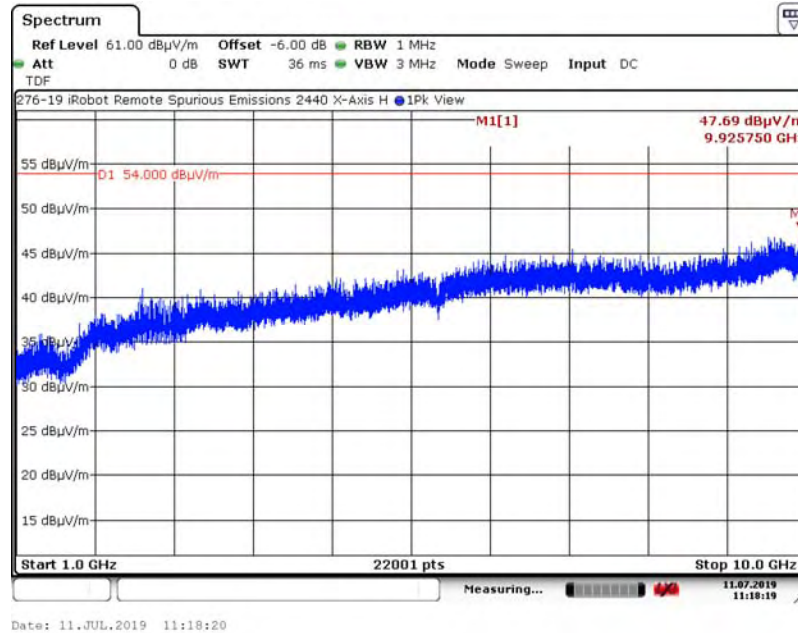

A4.2.2. Measurement Results: X-Axis, Vertical Antenna

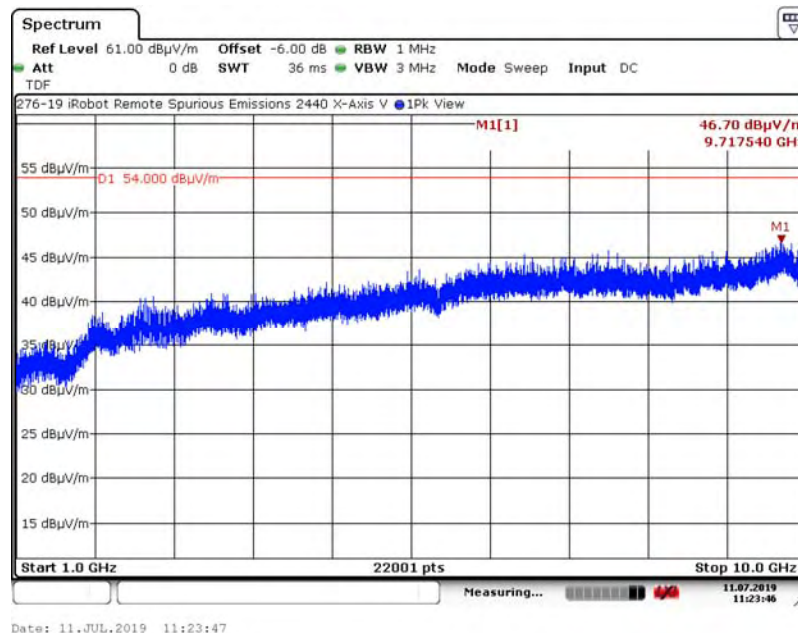

Appendix A - Transmitter Spurious Radiated Emissions (30 kHz to 25 GHz)

A4. Spurious Radiated Emissions (1 GHz – 10 GHz) Test Results

A4.2. Channel 17, 2440 MHz

A4.2.3. Measurement Results: Y-Axis, Horizontal Antenna

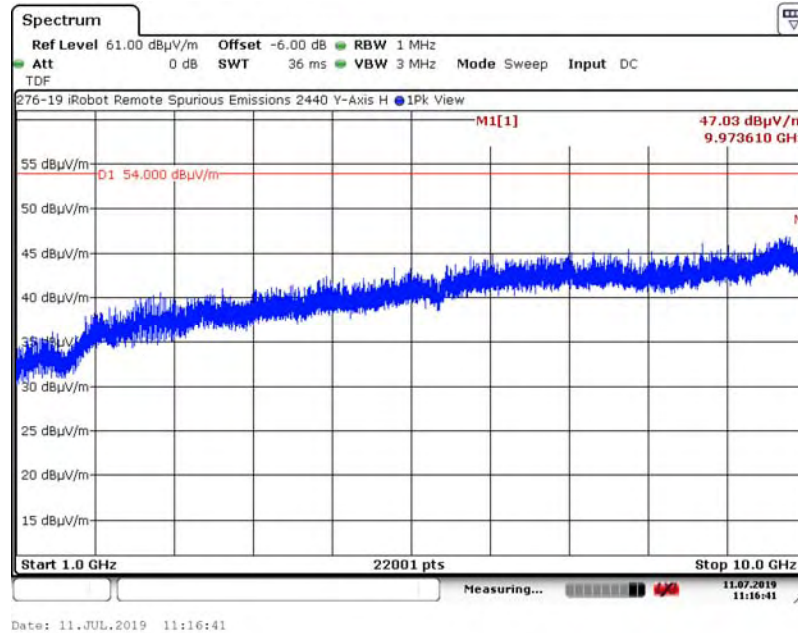

A4.2.4. Measurement Results: Y-Axis, Vertical Antenna

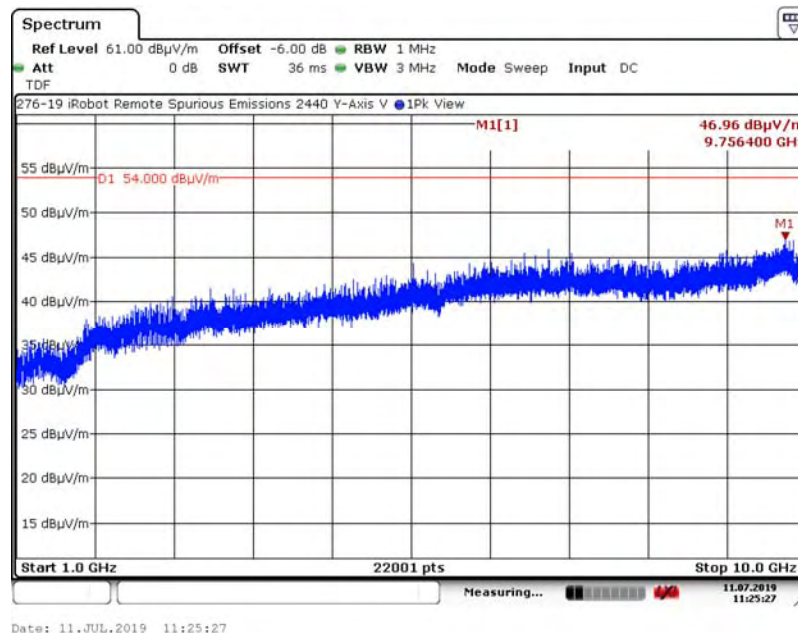

Appendix A - Transmitter Spurious Radiated Emissions (30 kHz to 25 GHz)

A4. Spurious Radiated Emissions (1 GHz – 10 GHz) Test Results

A4.2. Channel 17, 2440 MHz

A4.2.5. Measurement Results: Z-Axis, Horizontal Antenna

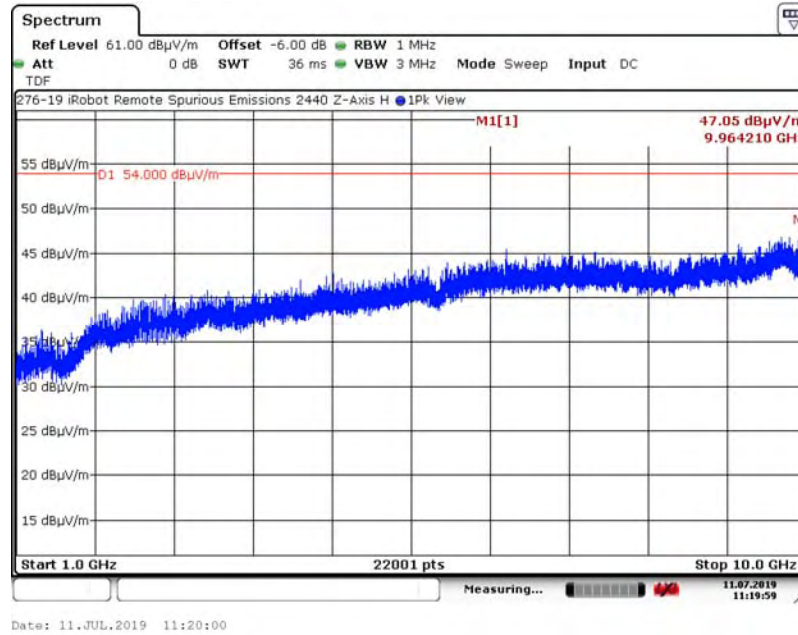

A4.2.6. Measurement Results: Z-Axis, Vertical Antenna

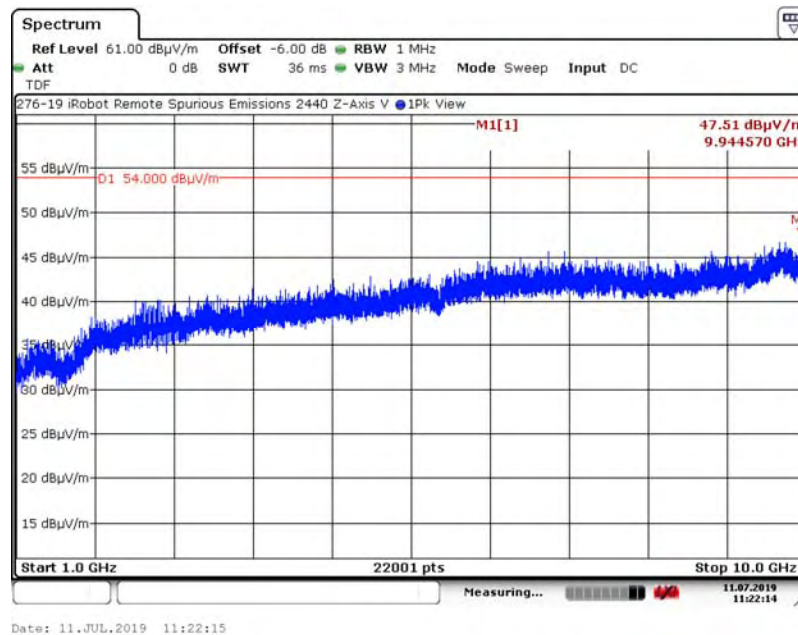

Appendix A - Transmitter Spurious Radiated Emissions (30 kHz to 25 GHz)

A4. Spurious Radiated Emissions (1 GHz – 10 GHz) Test Results

A4.3. Channel 39, 2480 MHz

A4.3.1. Measurement Results: X-Axis, Horizontal Antenna

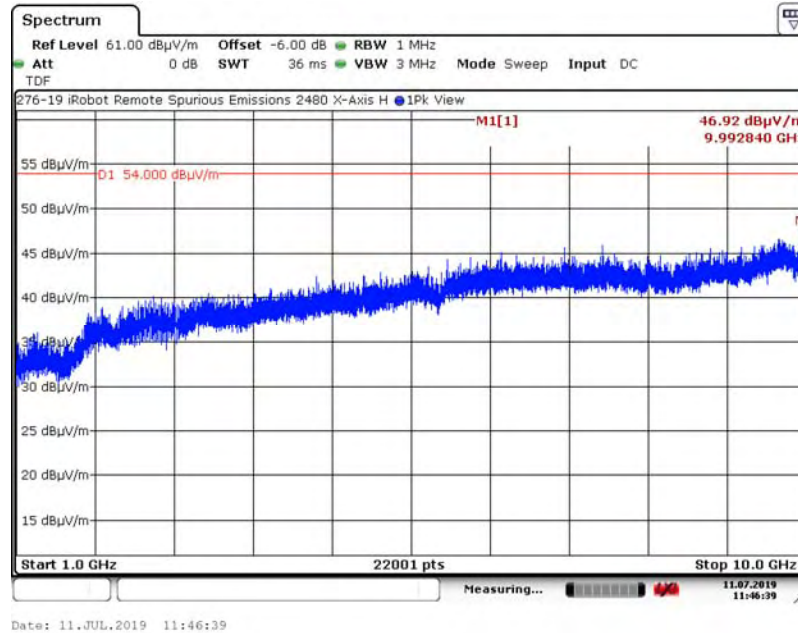

A4.3.2. Measurement Results: X-Axis, Vertical Antenna

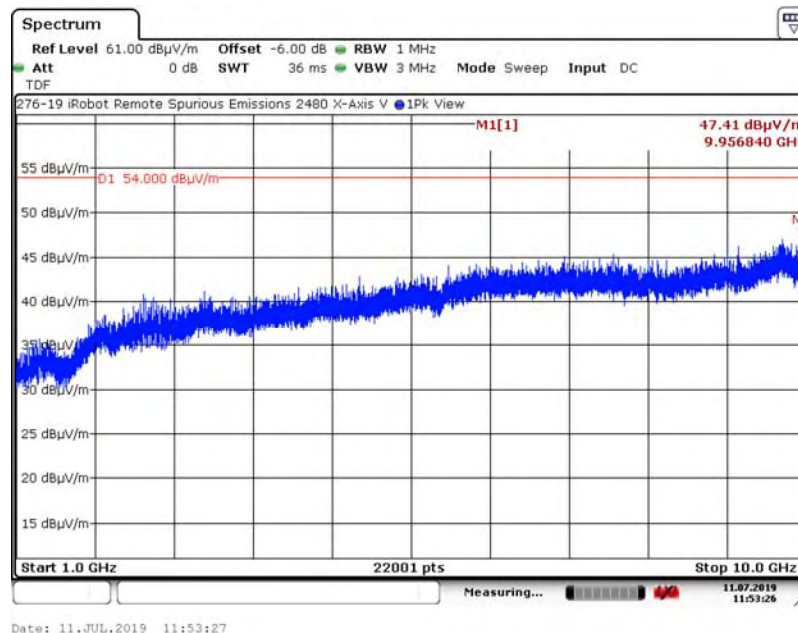

Appendix A - Transmitter Spurious Radiated Emissions (30 kHz to 25 GHz)

A4. Spurious Radiated Emissions (1 GHz – 10 GHz) Test Results

A4.3. Channel 39, 2480 MHz

A4.3.3. Measurement Results: Y-Axis, Horizontal Antenna

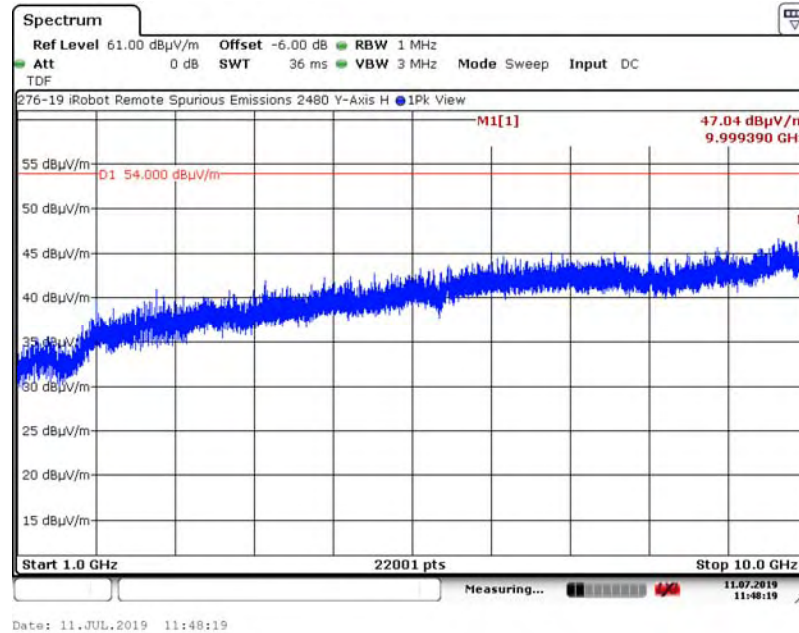

A4.3.4. Measurement Results: Y-Axis, Vertical Antenna

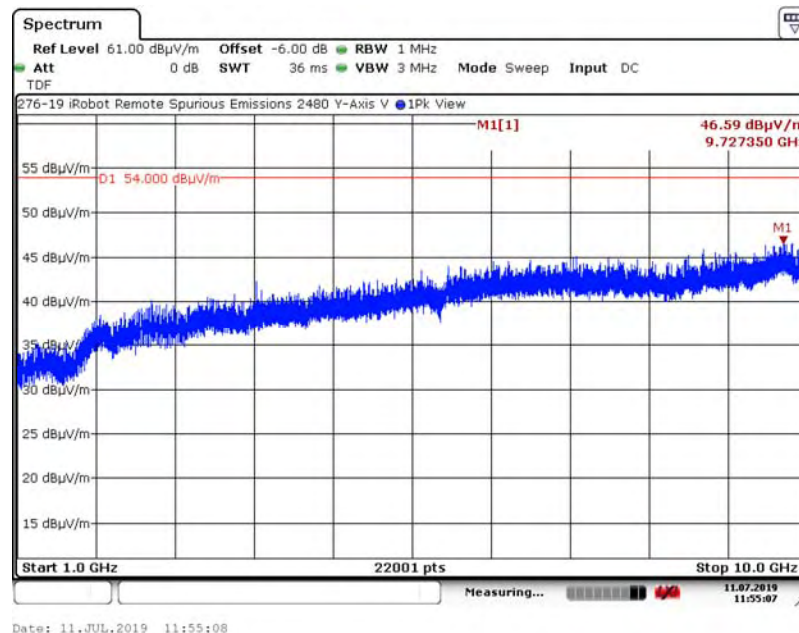

Appendix A - Transmitter Spurious Radiated Emissions (30 kHz to 25 GHz)

A4. Spurious Radiated Emissions (1 GHz – 10 GHz) Test Results

A4.3. Channel 39, 2480 MHz

A4.3.5. Measurement Results: Z-Axis, Horizontal Antenna

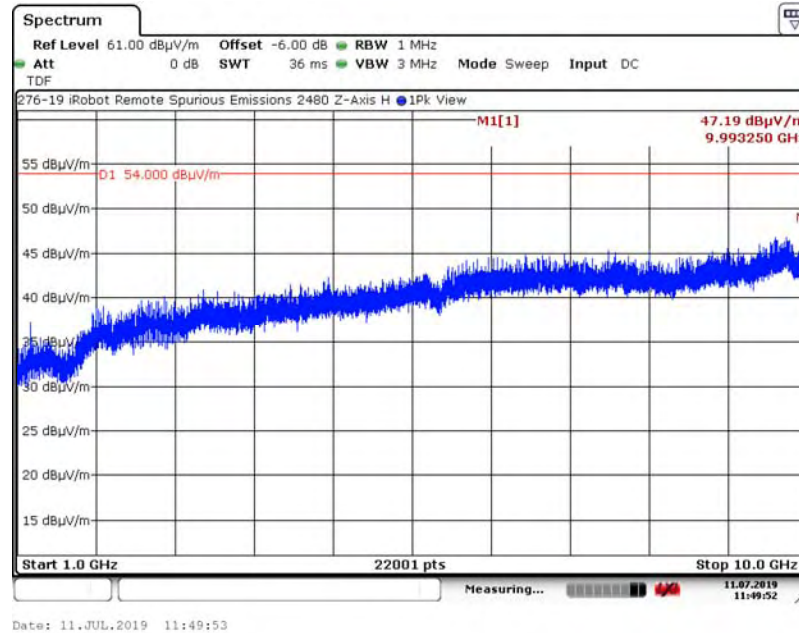

A4.3.6. Measurement Results: Z-Axis, Vertical Antenna

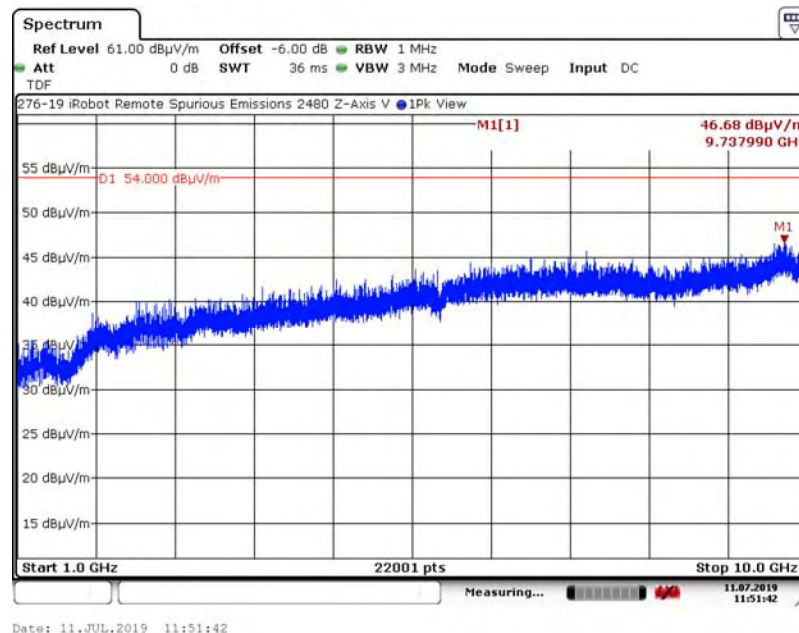

Appendix A - Transmitter Spurious Radiated Emissions (30 kHz to 25 GHz)

A5. Spurious Radiated Emissions (10 GHz – 18 GHz) Test Results

A5.1. Channel 37, 2402 MHz

A5.1.1. Measurement Results: X-Axis, Horizontal Antenna

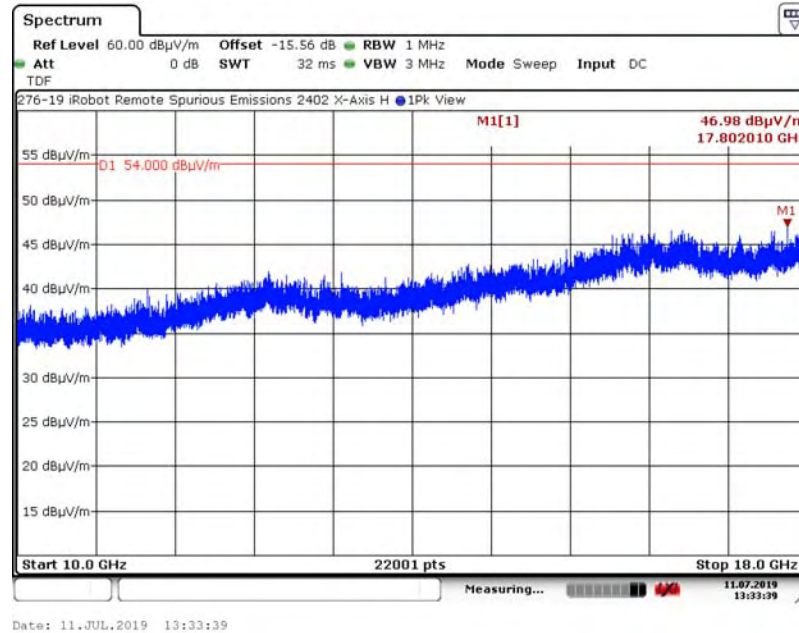

A5.1.2. Measurement Results: X-Axis, Vertical Antenna

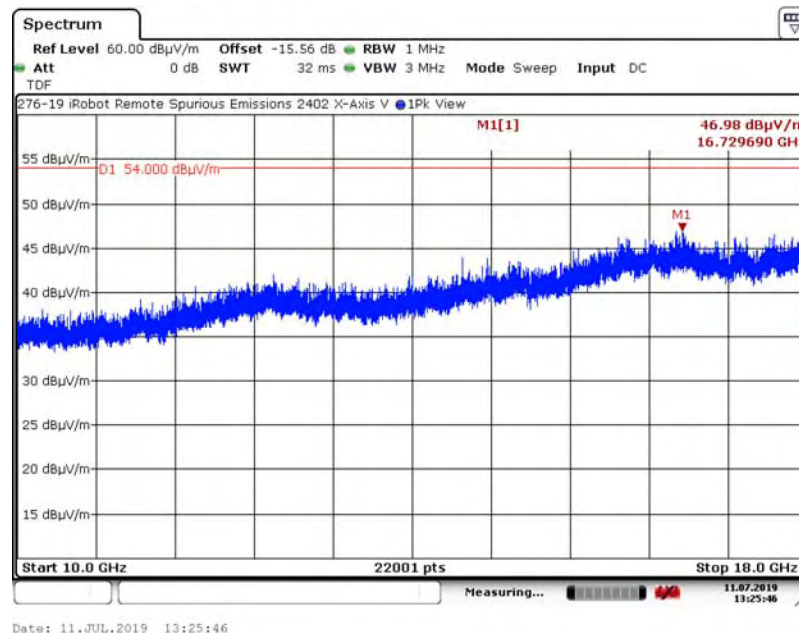

Appendix A - Transmitter Spurious Radiated Emissions (30 kHz to 25 GHz)

A5. Spurious Radiated Emissions (10 GHz – 18 GHz) Test Results

A5.1. Channel 37, 2402 MHz

A5.1.3. Measurement Results: Y-Axis, Horizontal Antenna

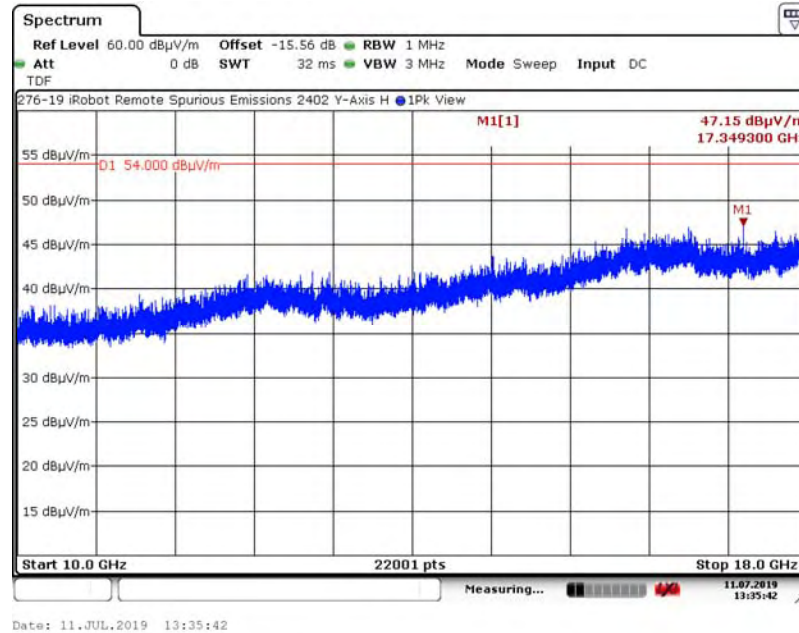

A5.1.4. Measurement Results: Y-Axis, Vertical Antenna

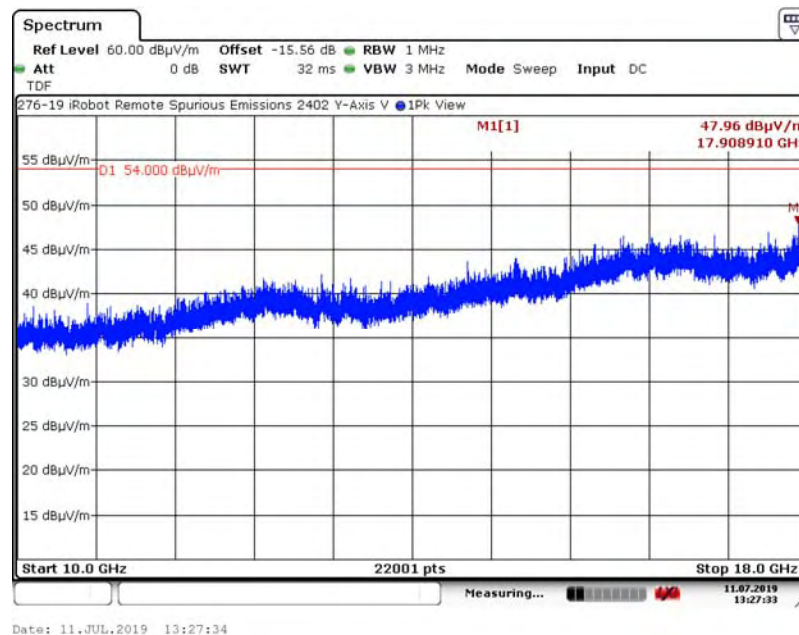

Appendix A - Transmitter Spurious Radiated Emissions (30 kHz to 25 GHz)

A5. Spurious Radiated Emissions (10 GHz – 18 GHz) Test Results

A5.1. Channel 37, 2402 MHz

A5.1.5. Measurement Results: Z-Axis, Horizontal Antenna

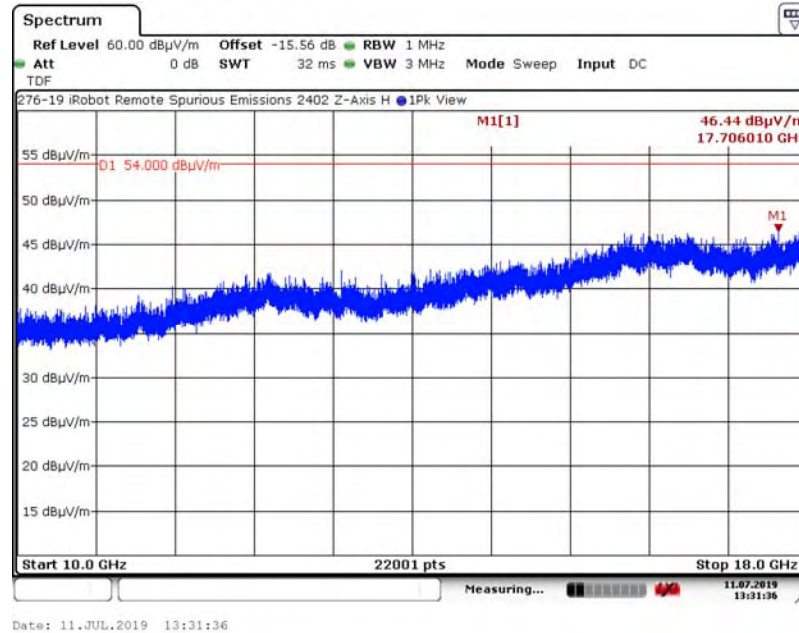

A5.1.6. Measurement Results: Z-Axis, Vertical Antenna

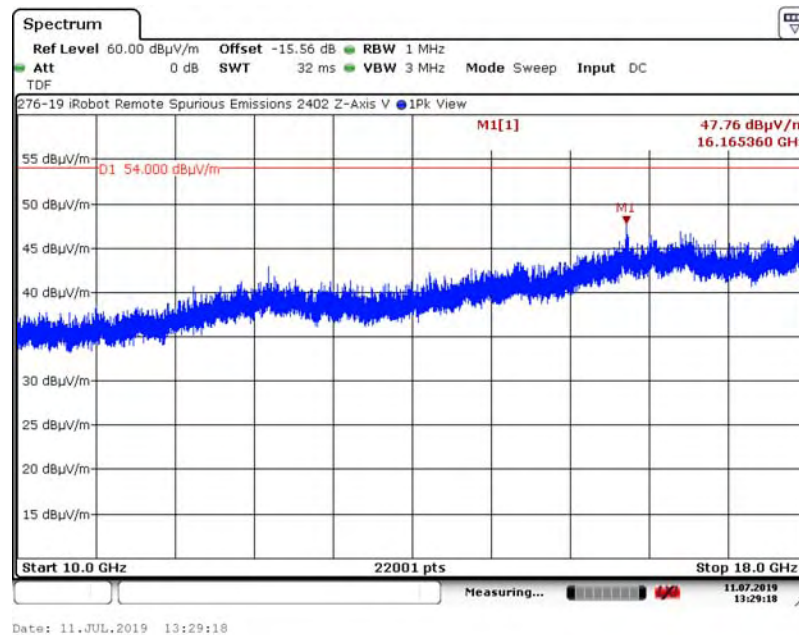

Appendix A - Transmitter Spurious Radiated Emissions (30 kHz to 25 GHz)

A5. Spurious Radiated Emissions (10 GHz – 18 GHz) Test Results

A5.2. Channel 17, 2440 MHz

A5.2.1. Measurement Results: X-Axis, Horizontal Antenna

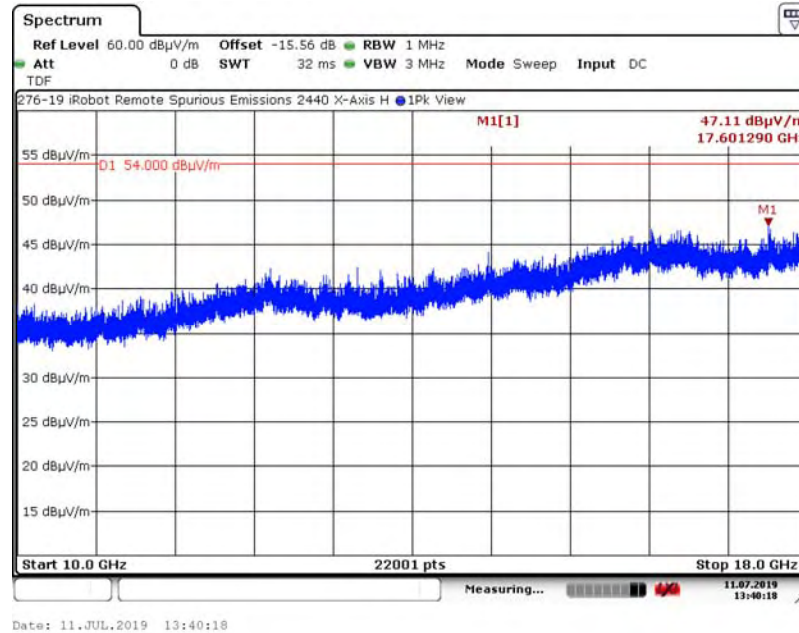

A5.2.2. Measurement Results: X-Axis, Vertical Antenna

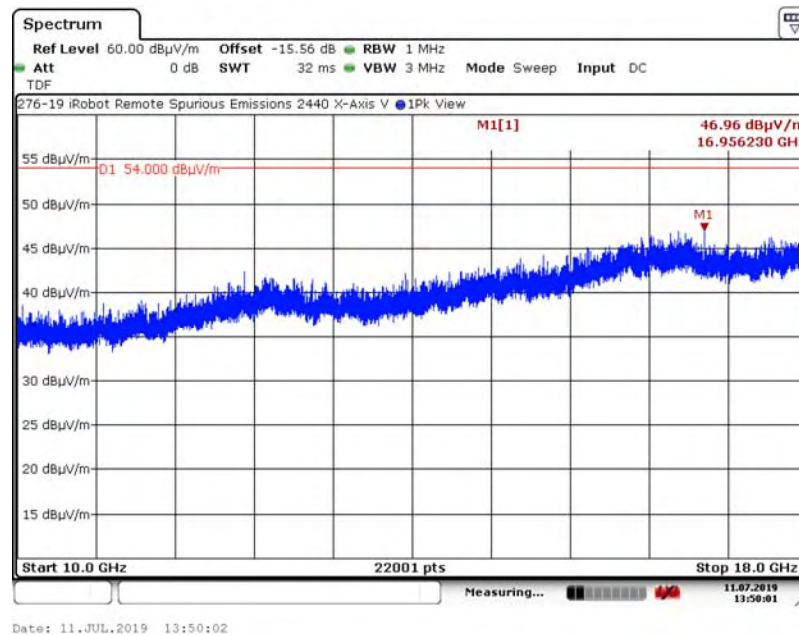

Appendix A - Transmitter Spurious Radiated Emissions (30 kHz to 25 GHz)

A5. Spurious Radiated Emissions (10 GHz – 18 GHz) Test Results

A5.2. Channel 17, 2440 MHz

A5.2.3. Measurement Results: Y-Axis, Horizontal Antenna

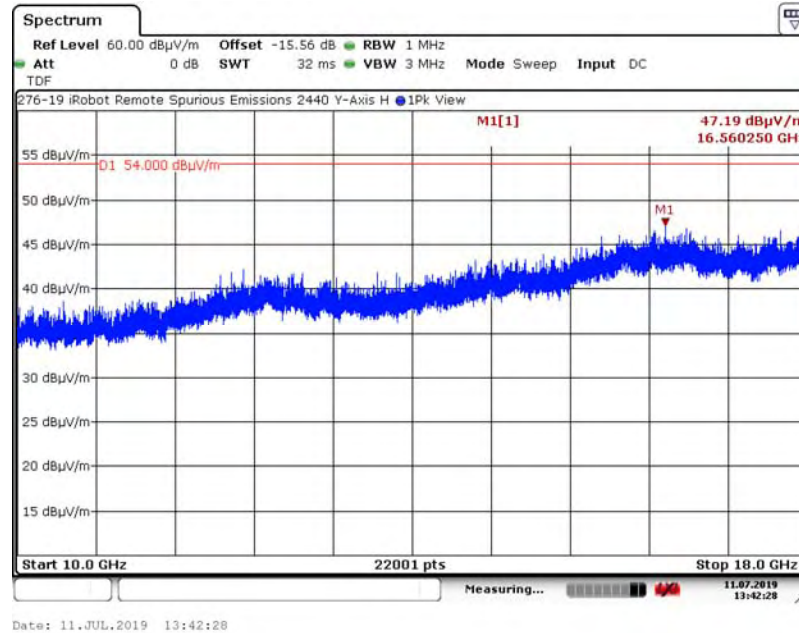

A5.2.4. Measurement Results: Y-Axis, Vertical Antenna

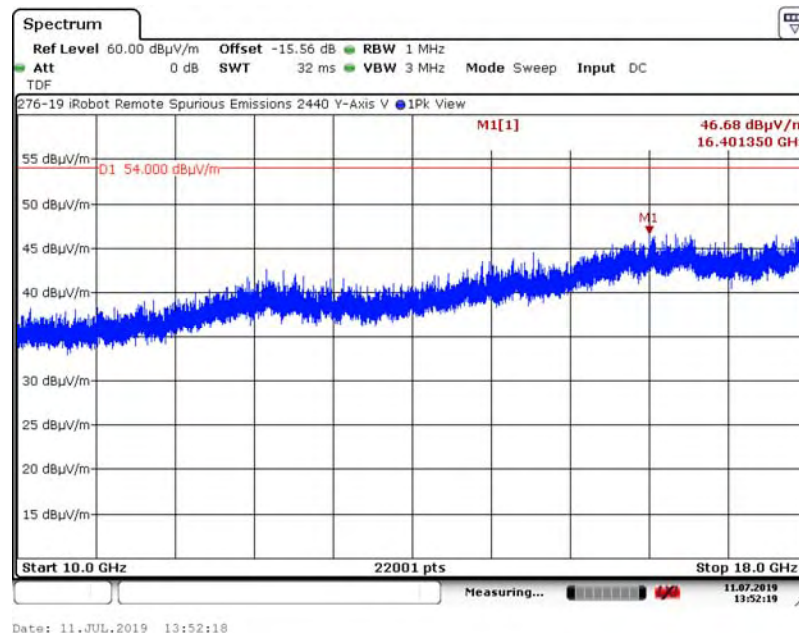

Appendix A - Transmitter Spurious Radiated Emissions (30 kHz to 25 GHz)

A5. Spurious Radiated Emissions (10 GHz – 18 GHz) Test Results

A5.2. Channel 17, 2440 MHz

A5.2.5. Measurement Results: Z-Axis, Horizontal Antenna

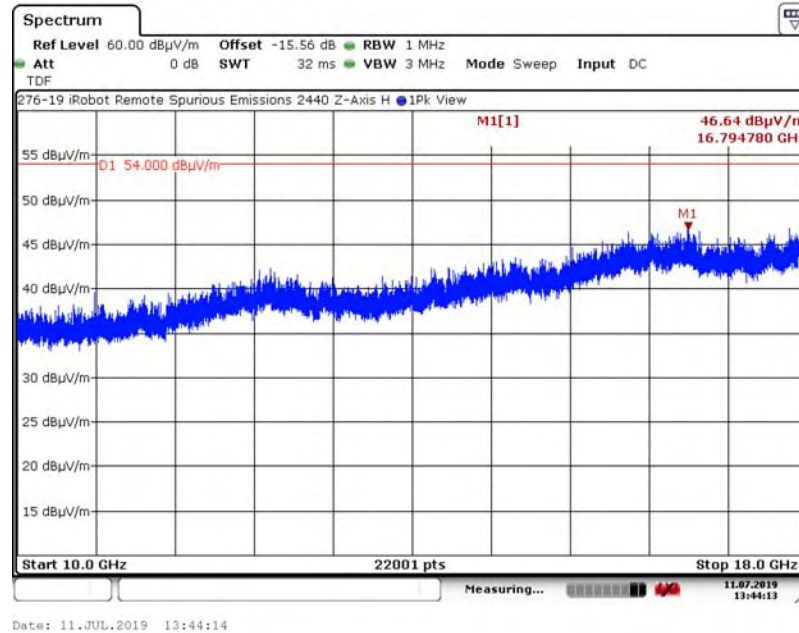

A5.2.6. Measurement Results: Z-Axis, Vertical Antenna

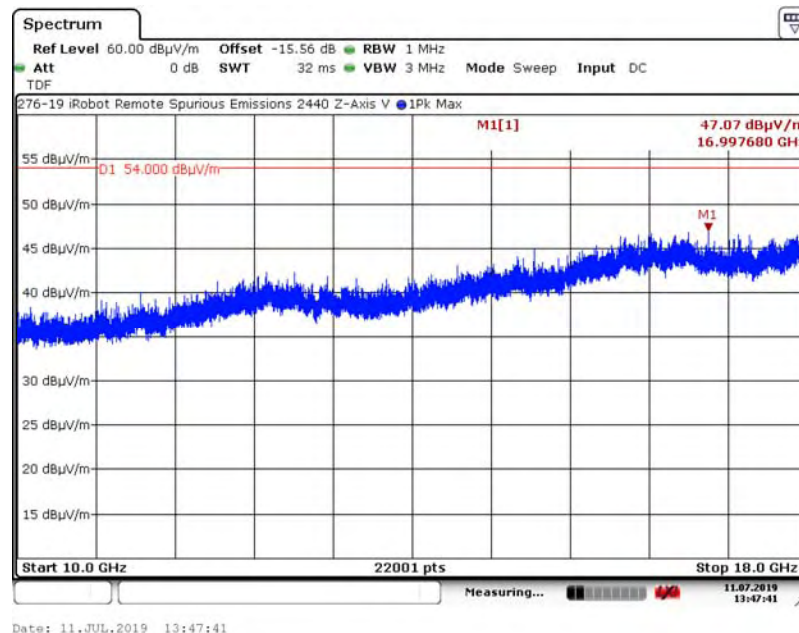

Appendix A - Transmitter Spurious Radiated Emissions (30 kHz to 25 GHz)

A5. Spurious Radiated Emissions (10 GHz – 18 GHz) Test Results

A5.3. Channel 39, 2480 MHz

A5.3.1. Measurement Results: X-Axis, Horizontal Antenna

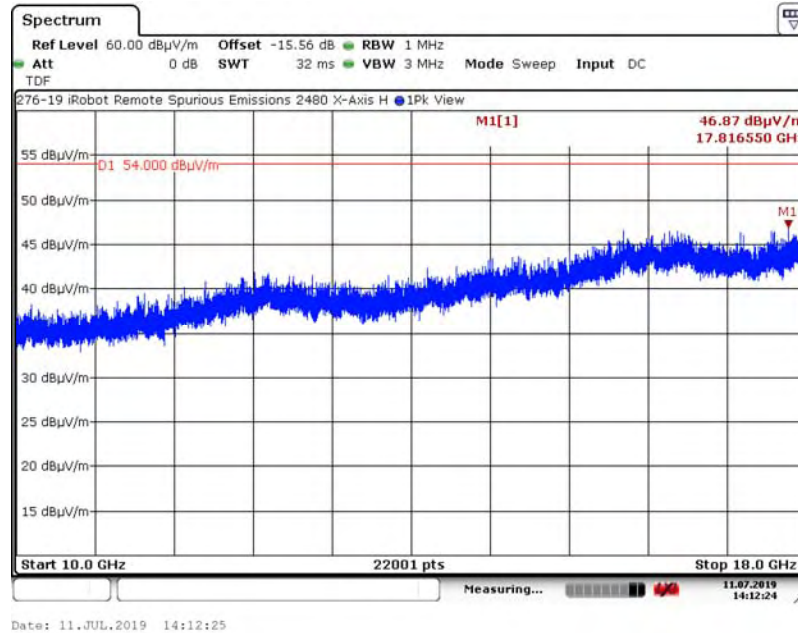

A5.3.2. Measurement Results: X-Axis, Vertical Antenna

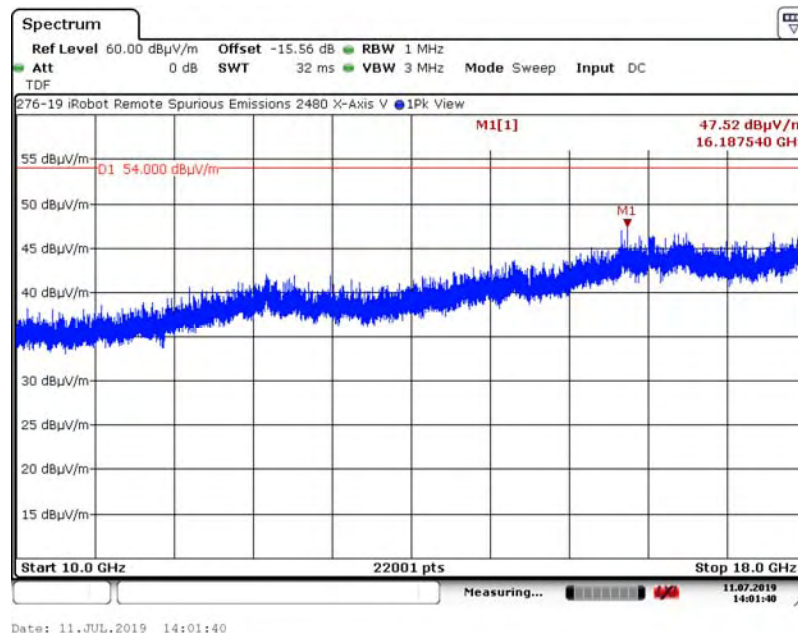

Appendix A - Transmitter Spurious Radiated Emissions (30 kHz to 25 GHz)

A5. Spurious Radiated Emissions (10 GHz – 18 GHz) Test Results

A5.3. Channel 39, 2480 MHz

A5.3.3. Measurement Results: Y-Axis, Horizontal Antenna

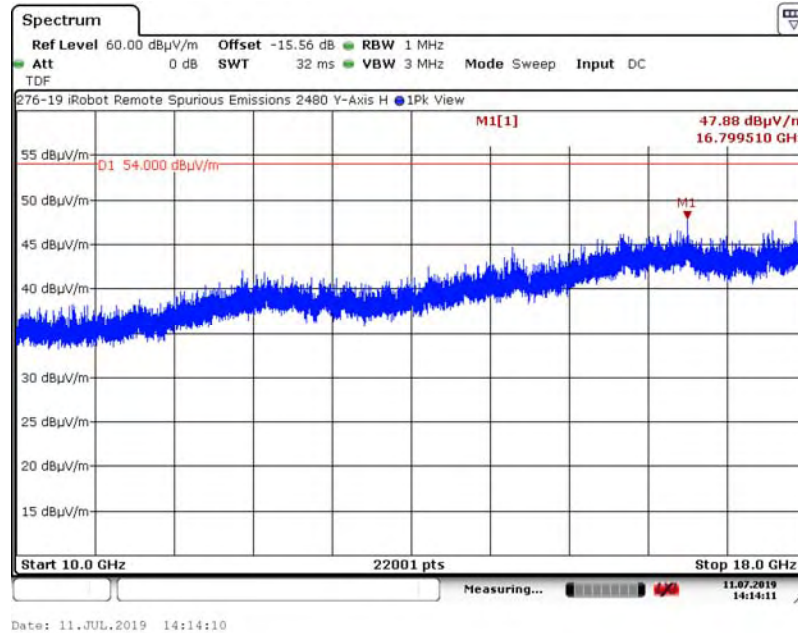

A5.3.4. Measurement Results: Y-Axis, Vertical Antenna

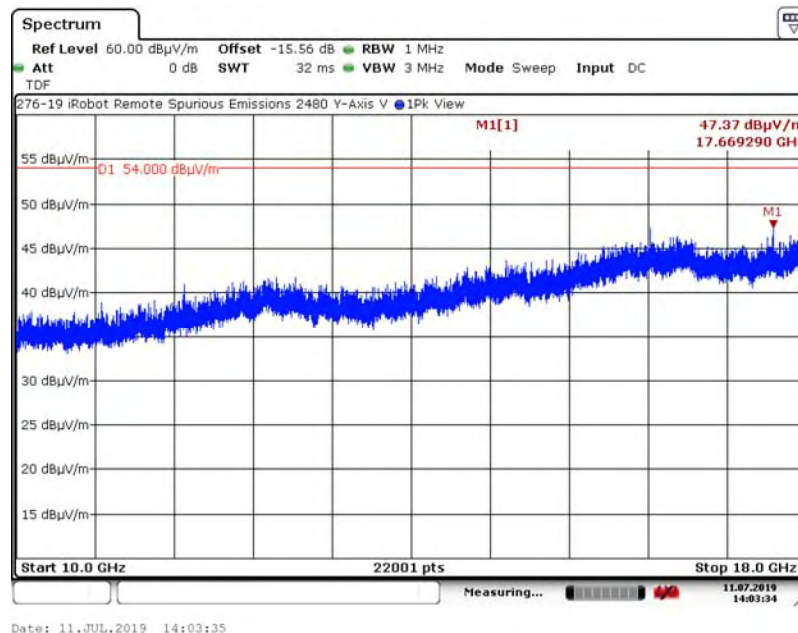

Appendix A - Transmitter Spurious Radiated Emissions (30 kHz to 25 GHz)

A5. Spurious Radiated Emissions (10 GHz – 18 GHz) Test Results

A5.3. Channel 39, 2480 MHz

A5.3.5. Measurement Results: Z-Axis, Horizontal Antenna

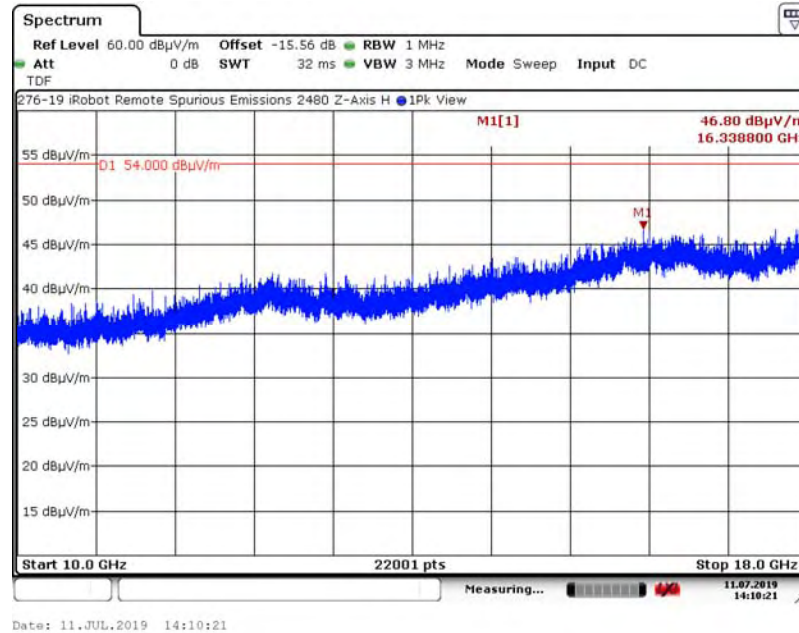

A5.3.6. Measurement Results: Z-Axis, Vertical Antenna

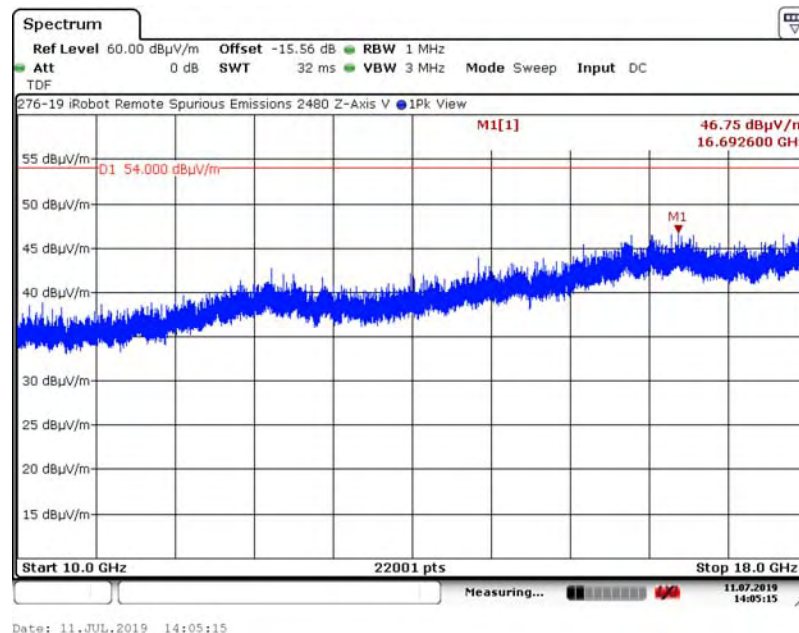

Appendix A - Transmitter Spurious Radiated Emissions (30 kHz to 25 GHz)

A6. Spurious Radiated Emissions (18 GHz – 25 GHz) Test Results

A6.1. Channel 37, 2402 MHz

A6.1.1. Measurement Results: X-Axis, Horizontal Antenna

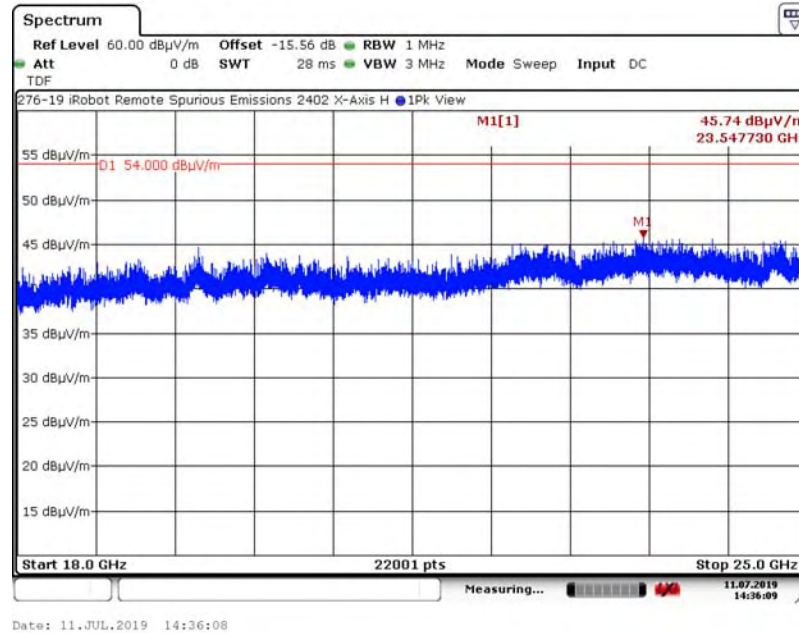

A6.1.2. Measurement Results: X-Axis, Vertical Antenna

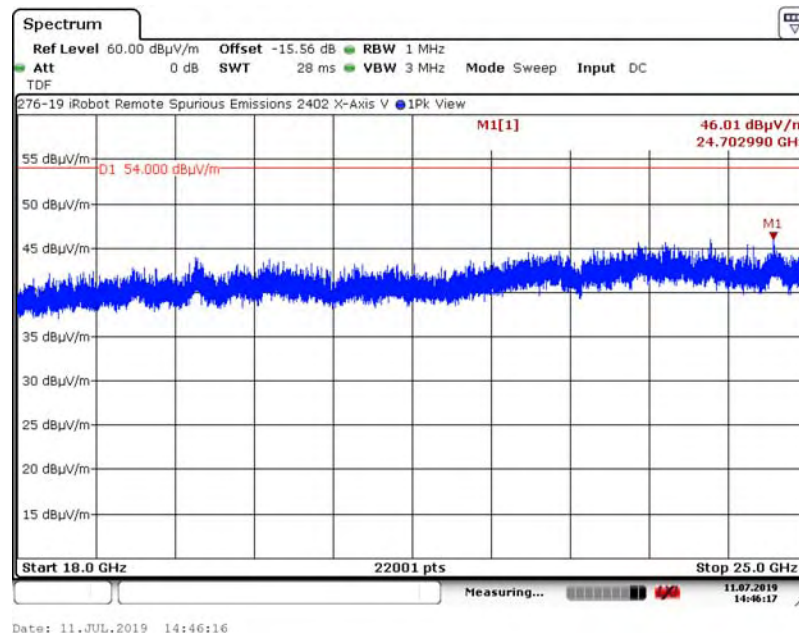

Appendix A - Transmitter Spurious Radiated Emissions (30 kHz to 25 GHz)

A6. Spurious Radiated Emissions (18 GHz – 25 GHz) Test Results

A6.1. Channel 37, 2402 MHz

A6.1.3. Measurement Results: Y-Axis, Horizontal Antenna

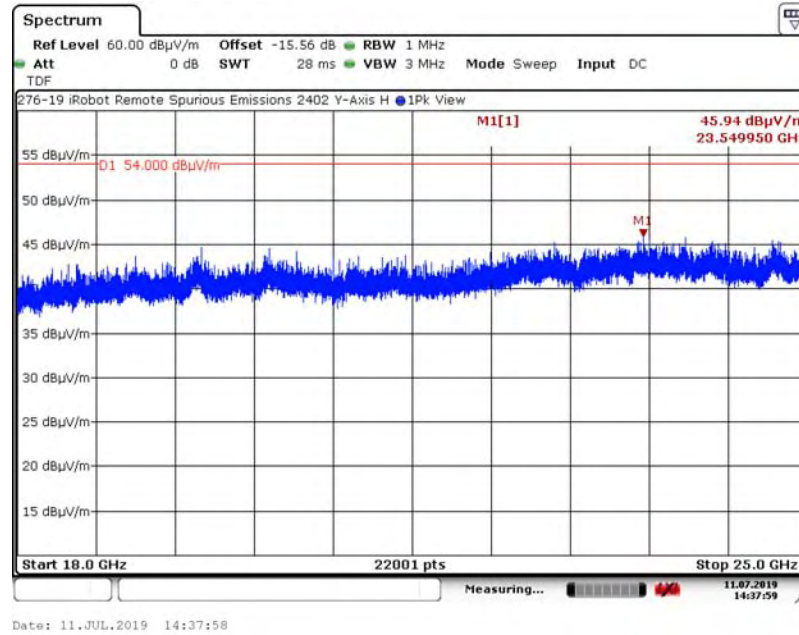

A6.1.4. Measurement Results: Y-Axis, Vertical Antenna

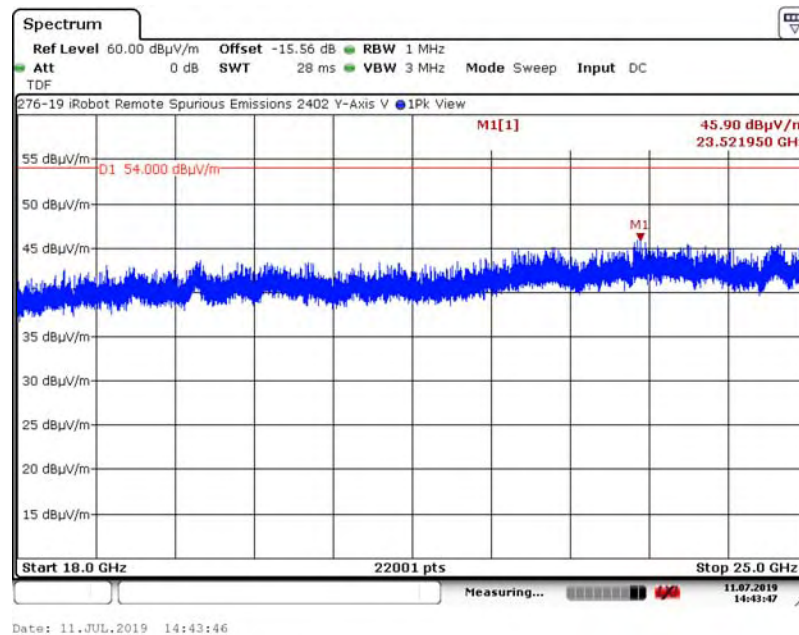

Appendix A - Transmitter Spurious Radiated Emissions (30 kHz to 25 GHz)

A6. Spurious Radiated Emissions (18 GHz – 25 GHz) Test Results

A6.1. Channel 37, 2402 MHz

A6.1.5. Measurement Results: Z-Axis, Horizontal Antenna

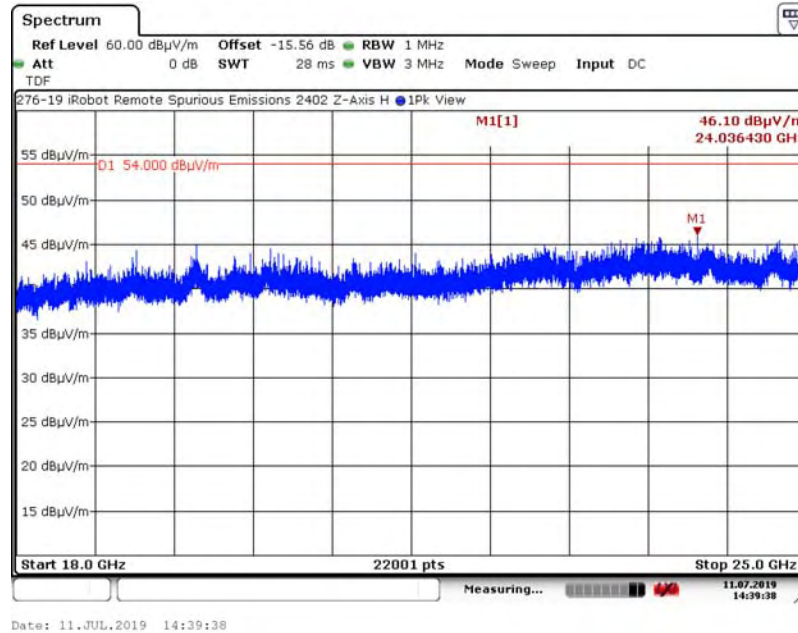

A6.1.6. Measurement Results: Z-Axis, Vertical Antenna

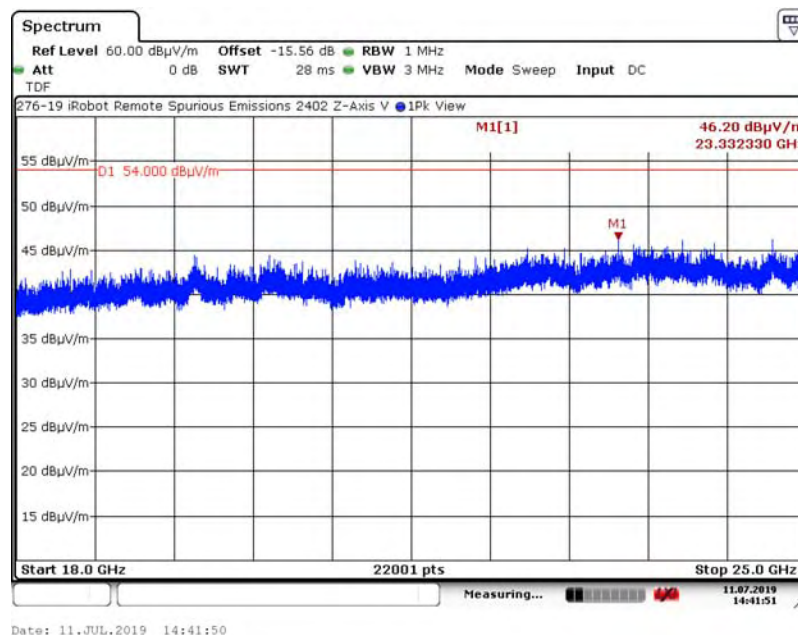

Appendix A - Transmitter Spurious Radiated Emissions (30 kHz to 25 GHz)

A6. Spurious Radiated Emissions (18 GHz – 25 GHz) Test Results

A6.2. Channel 39, 2480 MHz

A6.2.1. Measurement Results: X-Axis, Horizontal Antenna

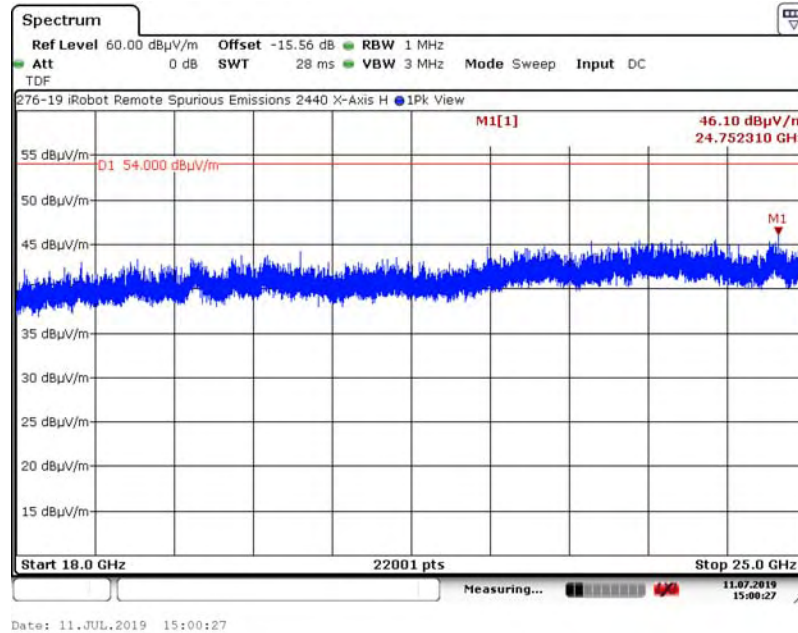

A6.2.2. Measurement Results: X-Axis, Vertical Antenna

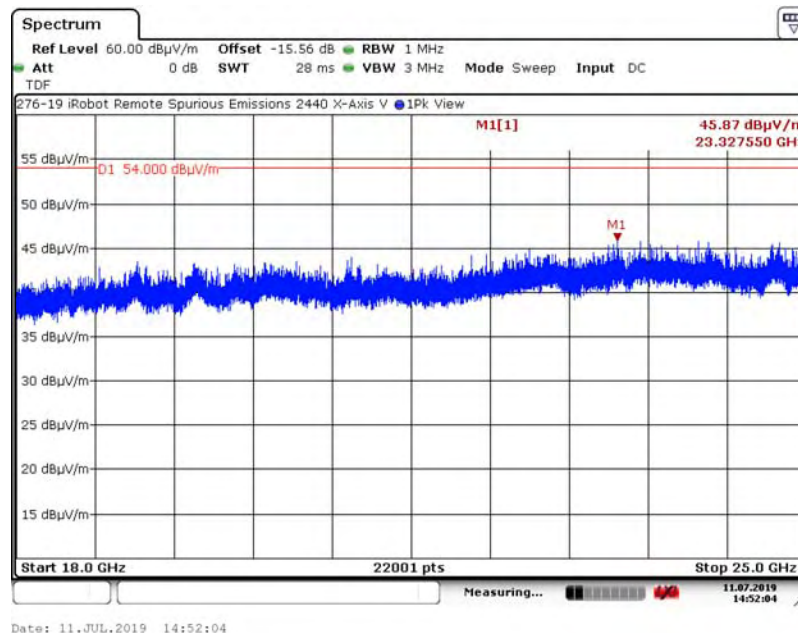

Appendix A - Transmitter Spurious Radiated Emissions (30 kHz to 25 GHz)

A6. Spurious Radiated Emissions (18 GHz – 25 GHz) Test Results

A6.2. Channel 17, 2440 MHz

A6.2.3. Measurement Results: Y-Axis, Horizontal Antenna

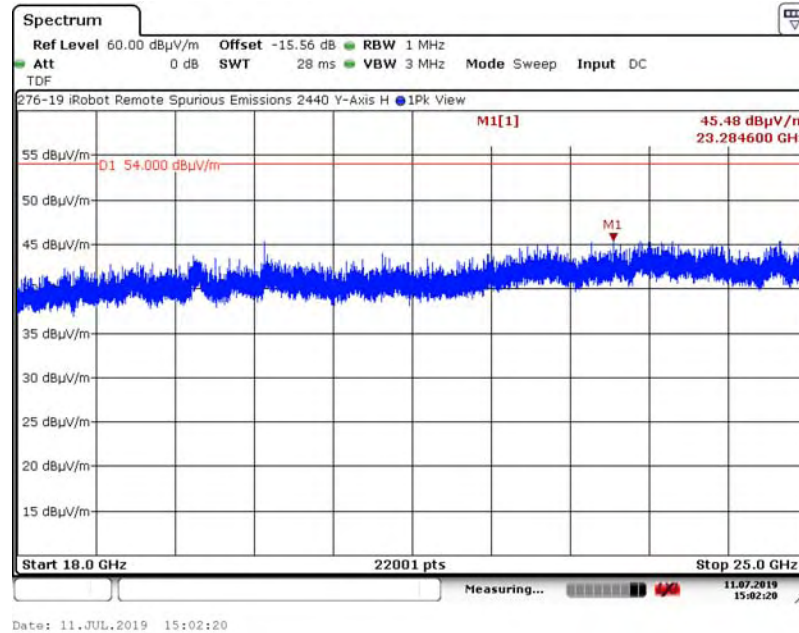

A6.2.4. Measurement Results: Y-Axis, Vertical Antenna

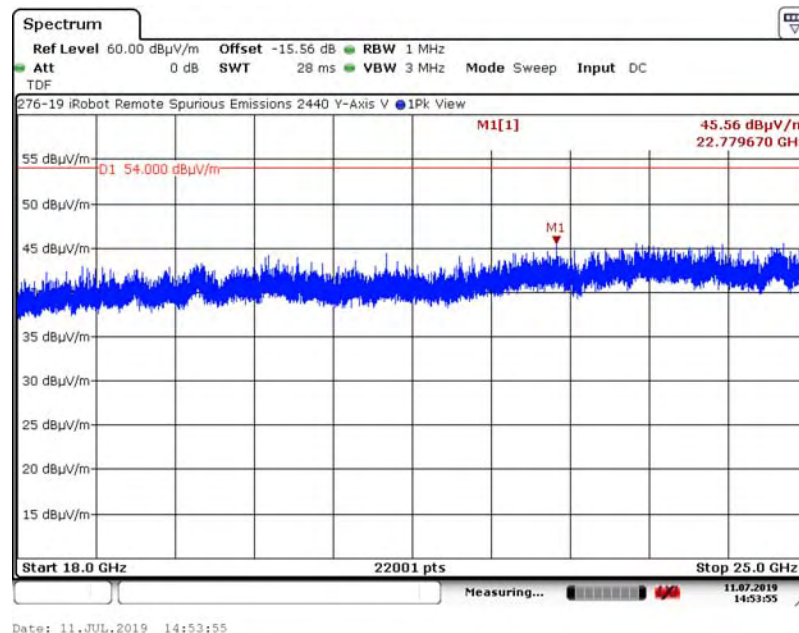

Appendix A - Transmitter Spurious Radiated Emissions (30 kHz to 25 GHz)

A6. Spurious Radiated Emissions (18 GHz – 25 GHz) Test Results

A6.2. Channel 17, 2440 MHz

A6.2.5. Measurement Results: Z-Axis, Horizontal Antenna

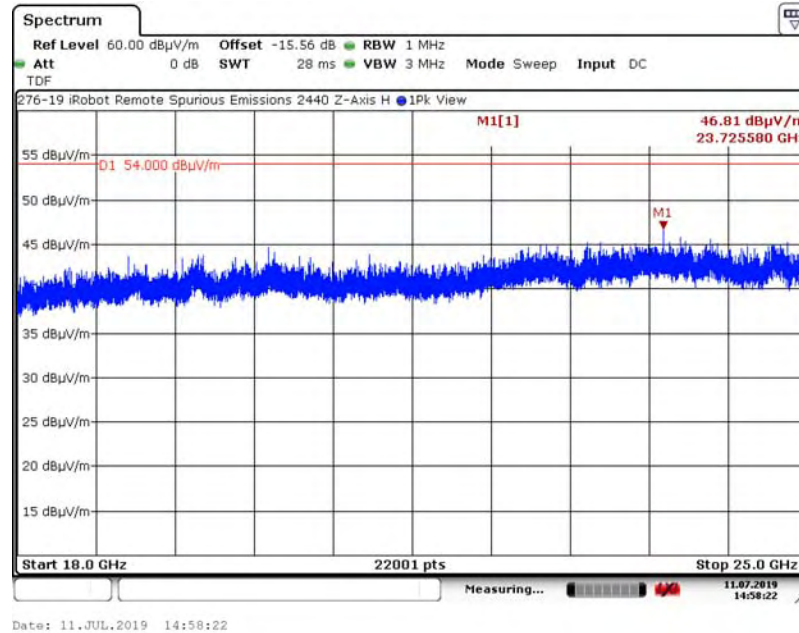

A6.2.6. Measurement Results: Z-Axis, Vertical Antenna

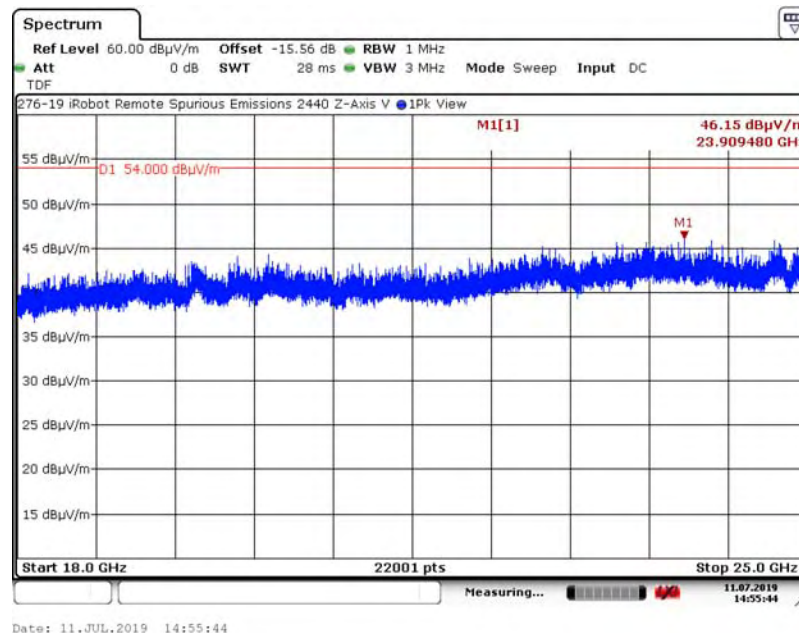

Appendix A - Transmitter Spurious Radiated Emissions (30 kHz to 25 GHz)

A6. Spurious Radiated Emissions (18 GHz – 25 GHz) Test Results

A6.2. Channel 39, 2480 MHz

A6.3.1. Measurement Results: X-Axis, Horizontal Antenna

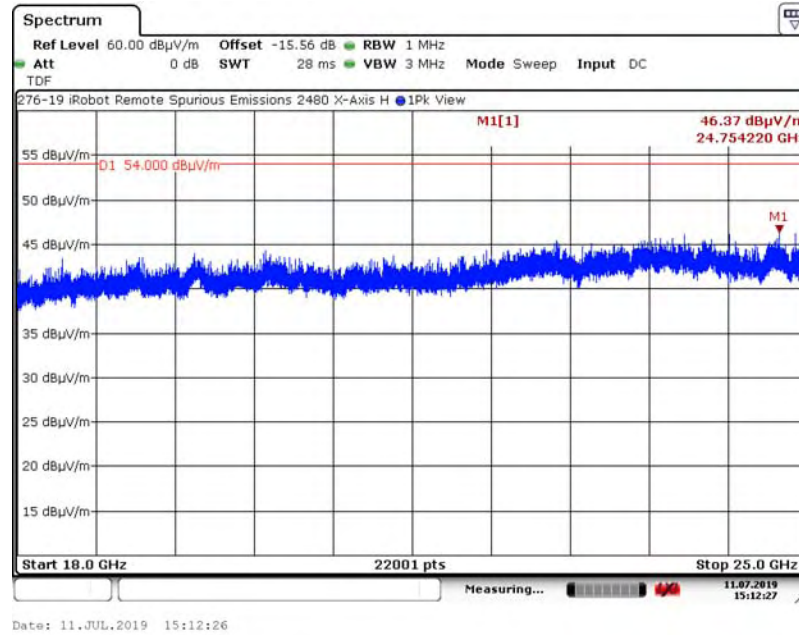

A6.3.2. Measurement Results: X-Axis, Vertical Antenna

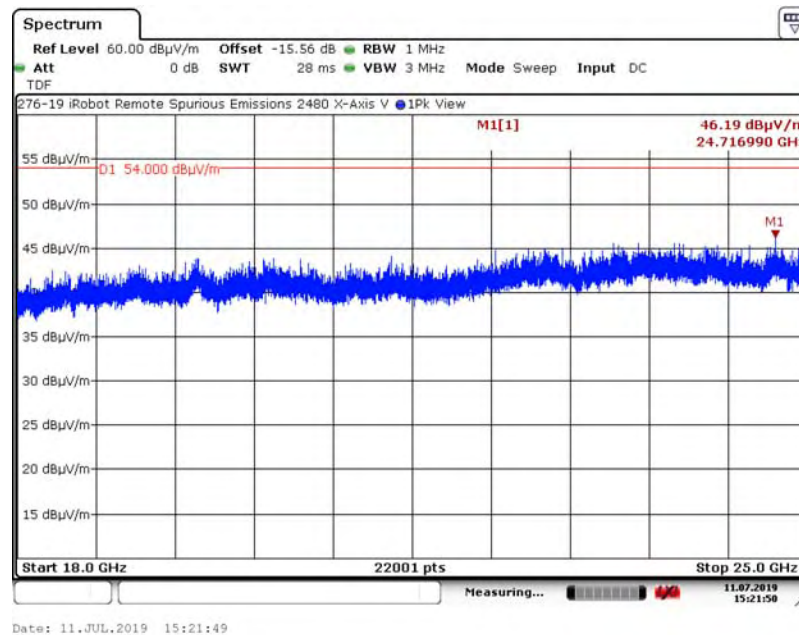

Appendix A - Transmitter Spurious Radiated Emissions (30 kHz to 25 GHz)

A6.2. Channel 39, 2480 MHz

A6.3.3. Measurement Results: Y-Axis, Horizontal Antenna

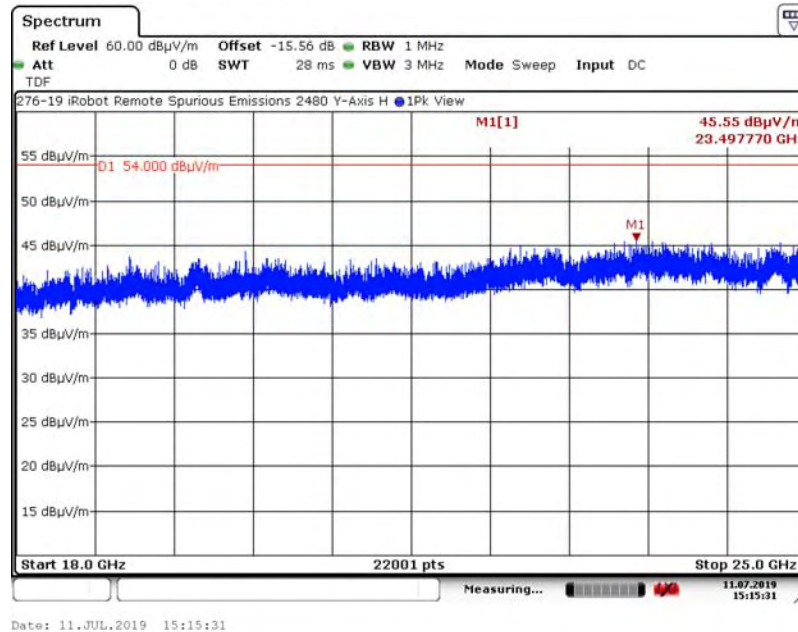

A6.3.4. Measurement Results: Y-Axis, Vertical Antenna

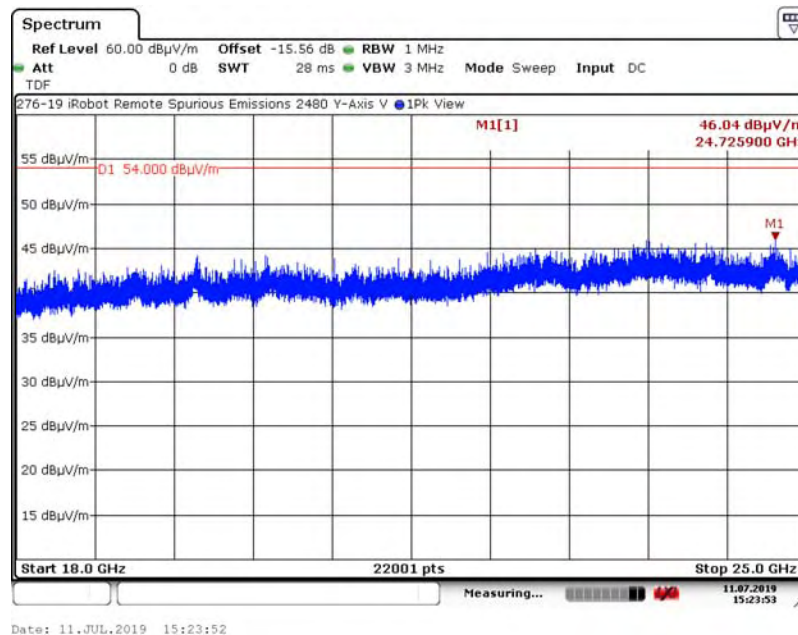

Appendix A - Transmitter Spurious Radiated Emissions (30 kHz to 25 GHz)

A6. Spurious Radiated Emissions (18 GHz – 25 GHz) Test Results

A6.2. Channel 39, 2480 MHz

A6.3.5. Measurement Results: Z-Axis, Horizontal Antenna

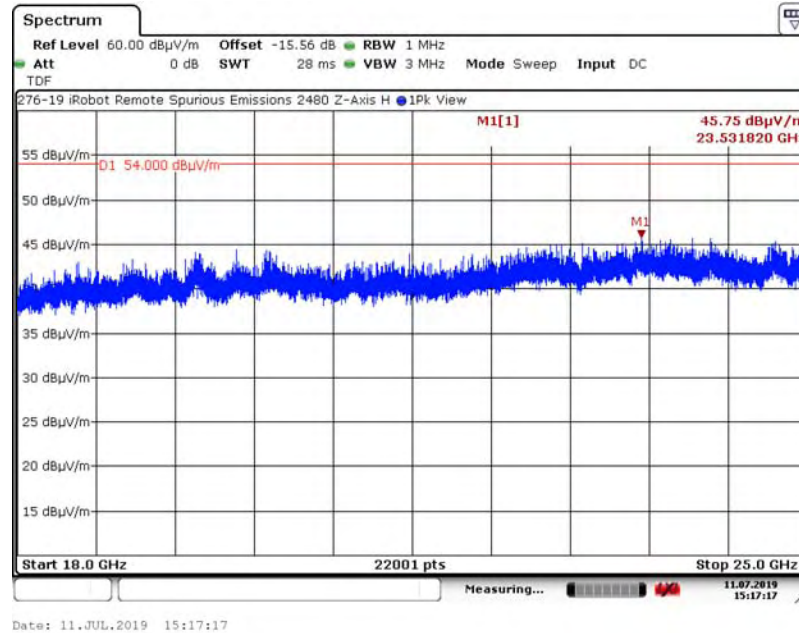

A6.3.6. Measurement Results: Z-Axis, Vertical Antenna

