



# RADIO TEST REPORT

**FCC ID** : UDX-60069010  
**Equipment** : Network Camera  
**Brand Name** : CISCO  
**Model Name** : MV2-HW  
**Applicant** : Cisco Systems, Inc.  
170 West Tasman Drive, San Jose, CA 95134, USA  
**Manufacturer** : Cisco Systems, Inc.  
170 West Tasman Drive, San Jose, CA 95134, USA  
**Factory** : LITE-ON Technology Corp. Networking Plant  
No. 101, Neihuan N. Rd., Nanzi Processing Export,  
Nanzi Dist., Kaohsiung City 811, Taiwan  
**Standard** : 47 CFR FCC Part 15.247

The product was received on Jan. 28, 2021, and testing was started from Jan. 29, 2021 and completed on Apr. 08, 2021. We, Sporton International Inc. Hsinchu Laboratory, would like to declare that the tested sample has been evaluated in accordance with the procedures given in ANSI C63.10-2013 and shown compliance with the applicable technical standards.

The test results in this report apply exclusively to the tested model / sample. Without written approval of Sporton International Inc. Hsinchu Laboratory, the test report shall not be reproduced except in full.

Approved by: Sam Chen

**Sporton International Inc. Hsinchu Laboratory**

No.8, Ln. 724, Bo'ai St., Zhubei City, Hsinchu County 302010, Taiwan (R.O.C.)



## Table of Contents

**History of this test report.....3**

**Summary of Test Result.....4**

**1 General Description .....5**

1.1 Information.....5

1.2 Applicable Standards .....8

1.3 Testing Location Information.....8

1.4 Measurement Uncertainty .....8

**2 Test Configuration of EUT .....9**

2.1 Test Channel Mode .....9

2.2 Test Voltage .....9

2.3 The Worst Case Measurement Configuration.....10

2.4 EUT Operation during Test .....11

2.5 Accessories .....12

2.6 Support Equipment.....12

2.7 Test Setup Diagram .....13

**3 Transmitter Test Result .....16**

3.1 AC Power-line Conducted Emissions .....16

3.2 DTS Bandwidth .....18

3.3 Maximum Conducted Output Power .....19

3.4 Power Spectral Density .....22

3.5 Emissions in Non-restricted Frequency Bands .....24

3.6 Emissions in Restricted Frequency Bands.....25

**4 Test Equipment and Calibration Data .....29**

**Appendix A. Test Results of AC Power-line Conducted Emissions**

**Appendix B. Test Results of DTS Bandwidth**

**Appendix C. Test Results of Maximum Conducted Output Power**

**Appendix D. Test Results of Power Spectral Density**

**Appendix E. Test Results of Emissions in Non-restricted Frequency Bands**

**Appendix F. Test Results of Emissions in Restricted Frequency Bands**

**Appendix G. Test Photos**

**Photographs of EUT v01**





## Summary of Test Result

Report Clause	Ref Std. Clause	Test Items	Result (PASS/FAIL)	Remark
1.1.2	15.203	Antenna Requirement	PASS	-
3.1	15.207	AC Power-line Conducted Emissions	PASS	-
3.2	15.247(a)	DTS Bandwidth	PASS	-
3.3	15.247(b)	Maximum Conducted Output Power	PASS	-
3.4	15.247(e)	Power Spectral Density	PASS	-
3.5	15.247(d)	Emissions in Non-restricted Frequency Bands	PASS	-
3.6	15.247(d)	Emissions in Restricted Frequency Bands	PASS	-

**Declaration of Conformity:**

The test results with all measurement uncertainty excluded are presented in accordance with the regulation limits or requirements declared by manufacturers.

**Comments and Explanations:**

The declared of product specification for EUT presented in the report are provided by the manufacturer, and the manufacturer takes all the responsibilities for the accuracy of product specification.

**Reviewed by: Sam Chen**

**Report Producer: Viola Huang**



# 1 General Description

## 1.1 Information

### 1.1.1 RF General Information

Frequency Range (MHz)	Bluetooth Mode	Ch. Frequency (MHz)	Channel Number
2400-2483.5	LE	2402-2480	0-39 [40]

Band	Mode	BWch (MHz)	Nant
2.4-2.4835GHz	BT-LE(1Mbps)	1	1

Note:

- ♦ Bluetooth LE uses a GFSK modulation.
- ♦ BWch is the nominal channel bandwidth.



1.1.2 Antenna Information

Ant.	Port			Brand	Model Name	Antenna Type	Connector	Gain (dBi)
	WLAN 2.4GHz	WLAN 5GHz	Bluetooth					
1	2	2	2	Aristotle	RFA-25-10159-P1-V3	PIFA Antenna	I-PEX	Note 1
2	1	1	1	Aristotle	RFA-25-10159-P2	PIFA Antenna	I-PEX	

Note 1:

Ant.	Gain (dBi)		
	WLAN 2.4GHz	WLAN 5GHz	Bluetooth
1	1.3	2.25	1.3
2	2.68	2.67	2.68

Note 2: The above information was declared by manufacturer.

Note 3: The EUT has two antennas.

**For 2.4GHz WLAN function**

**IEEE 802.11b/g/n mode (1TX/1RX):**

The EUT supports the antenna with TX and RX diversity functions.

Both port 1 and port 2 support transmit and receive functions, but only one of them will be used at one time.

The port 1 generated the worst case, so it was selected to test and record in the report.

**For 5GHz WLAN function**

**IEEE 802.11a/n/ac mode (1TX/1RX):**

The EUT supports the antenna with TX and RX diversity functions.

Both port 1 and port 2 support transmit and receive functions, but only one of them will be used at one time.

The port 1 generated the worst case, so it was selected to test and record in the report.

**For Bluetooth function (1TX/1RX):**

The EUT supports the antenna with TX and RX diversity functions.

Both port 1 and port 2 support transmit and receive functions, but only one of them will be used at one time.

The port 1 generated the worst case, so it was selected to test and record in the report.



**1.1.3 Mode Test Duty Cycle**

Mode	DC	DCF(dB)	T(s)	VBW(Hz) ≥ 1/T
BT-LE(1Mbps)	0.628	2.02	392.5u	3k

Note:

- ◆ DC is Duty Cycle.
- ◆ DCF is Duty Cycle Factor.

**1.1.4 EUT Operational Condition**

<b>EUT Power Type</b>	From Power Adapter		
<b>Function</b>	<input checked="" type="checkbox"/> Point-to-multipoint	<input type="checkbox"/> Point-to-point	
<b>Test Software Version</b>	QRCT.exe Version 4.0.00156.0		
<b>Support Mode</b>	<input checked="" type="checkbox"/> LE 1M PHY: 1 Mb/s		
	<input type="checkbox"/> LE Coded PHY (S=2): 500 Kb/s		
	<input type="checkbox"/> LE Coded PHY (S=8): 125 Kb/s		
	<input type="checkbox"/> LE 2M PHY: 2 Mb/s		

Note: The above information was declared by manufacturer.



### 1.2 Applicable Standards

According to the specifications of the manufacturer, the EUT must comply with the requirements of the following standards:

- ♦ 47 CFR FCC Part 15
- ♦ ANSI C63.10-2013

The following reference test guidance is not within the scope of accreditation of TAF.

- ♦ FCC KDB 558074 D01 v05r02
- ♦ FCC KDB 414788 D01 v01r01

### 1.3 Testing Location Information

Testing Location Information	
Test Lab. : Sporton International Inc. Hsinchu Laboratory	
Hsinchu	ADD: No.8, Ln. 724, Bo'ai St., Zhubei City, Hsinchu County 302010, Taiwan (R.O.C.)
(TAF: 3787)	TEL: 886-3-656-9065 FAX: 886-3-656-9085
	Test site Designation No. TW3787 with FCC.
	Conformity Assessment Body Identifier (CABID) TW3787 with ISED.

Test Condition	Test Site No.	Test Engineer	Test Environment (°C / %)	Test Date
RF Conducted	TH03-CB	Nyle Chang	20.4~21.2 / 54~57	Feb. 02, 2021~Feb. 03, 2021
Radiated (for below 1GHz)	03CH05-CB	Cola Fan	21.3~22.5 / 55~58	Apr. 08, 2021
Radiated (for above 1GHz)	03CH01-CB	Brian Sun	21~22.2 / 55~57	Jan. 29, 2021~Feb. 01, 2021
AC Conduction	CO02-CB	Ryo Fan	21~22 / 58~59	Feb. 26, 2021

### 1.4 Measurement Uncertainty

ISO/IEC 17025 requires that an estimate of the measurement uncertainties associated with the emissions test results be included in the report. The measurement uncertainties given below are based on a 95% confidence level (based on a coverage factor (k=2))

Test Items	Uncertainty	Remark
Conducted Emission (150kHz ~ 30MHz)	2.0 dB	Confidence levels of 95%
Radiated Emission (9kHz ~ 30MHz)	3.8 dB	Confidence levels of 95%
Radiated Emission (30MHz ~ 1,000MHz)	5.6 dB	Confidence levels of 95%
Radiated Emission (1GHz ~ 18GHz)	5.0 dB	Confidence levels of 95%
Radiated Emission (18GHz ~ 40GHz)	4.9 dB	Confidence levels of 95%
Conducted Emission	2.8 dB	Confidence levels of 95%
Output Power Measurement	1.4 dB	Confidence levels of 95%
Power Density Measurement	2.8 dB	Confidence levels of 95%
Bandwidth Measurement	0.4%	Confidence levels of 95%





## 2 Test Configuration of EUT

### 2.1 Test Channel Mode

Mode	Power Setting
BT-LE(1Mbps)	-
2402MHz	Default
2440MHz	Default
2480MHz	Default

### 2.2 Test Voltage

120 V / 60 Hz



### 2.3 The Worst Case Measurement Configuration

The Worst Case Mode for Following Conformance Tests	
<b>Tests Item</b>	AC power-line conducted emissions
<b>Condition</b>	AC power-line conducted measurement for line and neutral
<b>Operating Mode</b>	Normal Link
1	EUT_2.4GHz + powered from adapter
2	EUT_5GHz + powered from adapter
Mode 2 has been evaluated to be the worst case among Mode 1~2, thus measurement for Mode 3 will follow this same test mode.	
3	EUT_5GHz + powered from host system
For operating mode 2 is the worst case and it was record in this test report.	

The Worst Case Mode for Following Conformance Tests	
<b>Tests Item</b>	DTS Bandwidth Maximum Conducted Output Power Power Spectral Density Emissions in Non-restricted Frequency Bands
<b>Test Condition</b>	Conducted measurement at transmit chains

The Worst Case Mode for Following Conformance Tests	
<b>Tests Item</b>	Emissions in Restricted Frequency Bands
<b>Test Condition</b>	Radiated measurement If EUT consist of multiple antenna assembly (multiple antenna are used in EUT regardless of spatial multiplexing MIMO configuration), the radiated test should be performed with highest antenna gain of each antenna type.
<b>Operating Mode &lt; 1GHz</b>	Normal Link
1	EUT in Z axis_2.4GHz + powered from adapter
2	EUT in Y axis _2.4GHz + powered from adapter
Mode 2 has been evaluated to be the worst case among Mode 1~2, thus measurement for Mode 3 will follow this same test mode.	
3	EUT in Y axis _5GHz + powered from adapter
Mode 2 has been evaluated to be the worst case among Mode 1~3, thus measurement for Mode 4 will follow this same test mode.	
4	EUT in Y axis _2.4GHz + powered from host system
For operating mode 4 is the worst case and it was record in this test report.	



<b>Operating Mode &gt; 1GHz</b>	CTX
	The EUT was performed at Y axis and Z axis position and the worst case was found at Z axis. So the measurement will follow this same test
1	EUT in Z axis

## 2.4 EUT Operation during Test

For CTX Mode:

The EUT was programmed to be in continuously transmitting mode.

For Normal Link:

During the test, the EUT operation to normal function.



## 2.5 Accessories

Accessories			
Equipment Name	Brand Name	Model Name	Rating
AC Adapter	CISCO	MA-PWR-USB-US	INPUT: 100-240V, 50-60Hz, 0.32A max OUTPUT: 5.0V, 2.0A
Others			
USB cable*1, Shielded, 3m			
Wall Mount*1			

## 2.6 Support Equipment

### For AC Conduction:

Support Equipment				
No.	Equipment	Brand Name	Model Name	FCC ID
A	AP Router	ASUS	RP-N53	MSQ-RPN53
B	AP NB	DELL	E6430	N/A
C	Smart phone	Samsung	Galaxy J2	N/A

### For Radiated (below 1GHz):

Support Equipment				
No.	Equipment	Brand Name	Model Name	FCC ID
A	Notebook	DELL	E4300	N/A
B	Notebook	DELL	E4300	N/A
C	WLAN AP	D-LINK	DIR860L	KA2IR860LA1
D	Smart phone	Samsung	Galaxy J2	N/A
E	Earphone	e-Power	S90W	N/A
F	Mouse	Logitech	M-U0026	N/A

### For Radiated (above 1GHz) and RF Conducted:

Support Equipment				
No.	Equipment	Brand Name	Model Name	FCC ID
A	Notebook	DELL	E4300	N/A

## 2.7 Test Setup Diagram

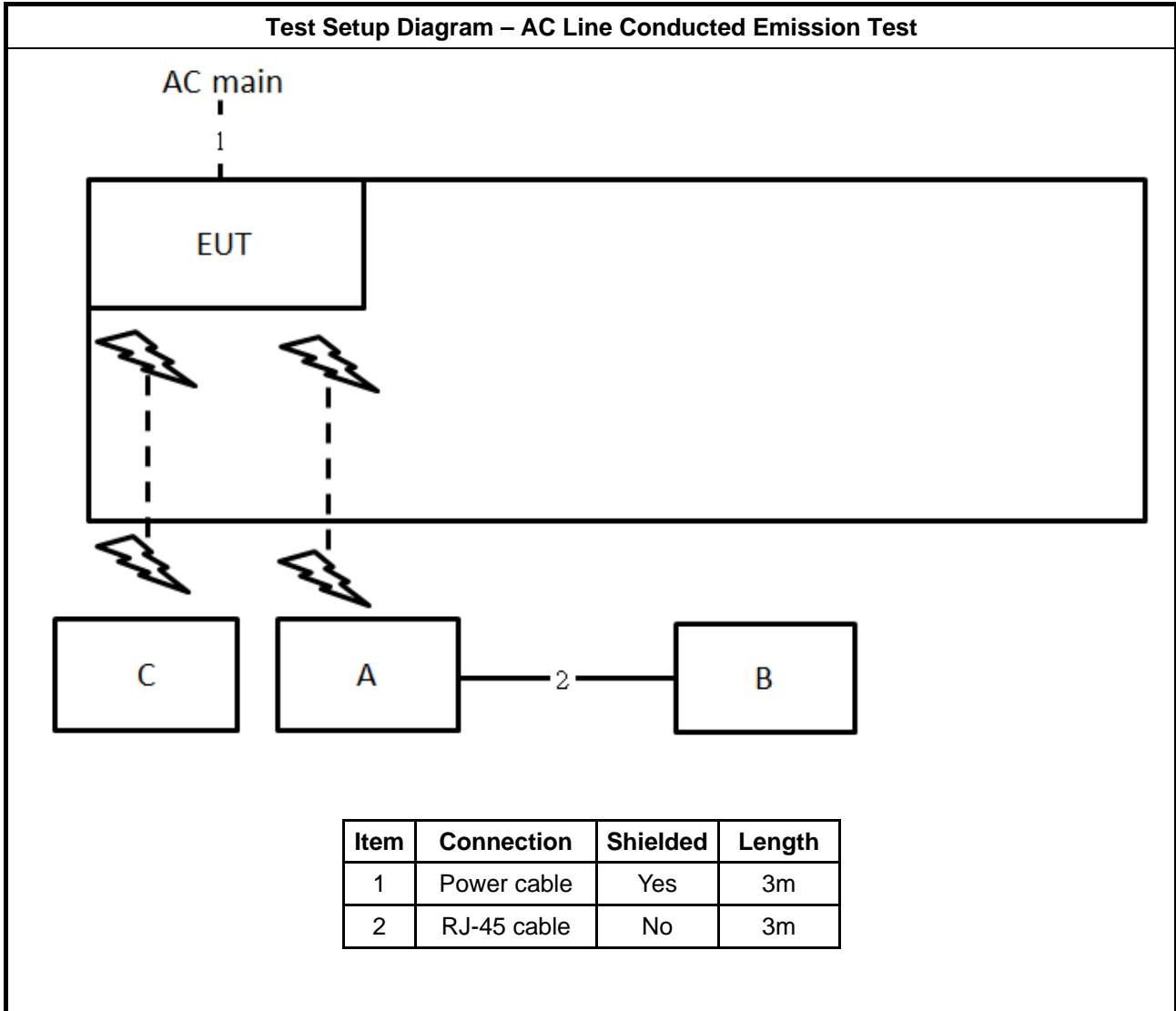

**Test Setup Diagram - Radiated Test < 1GHz**

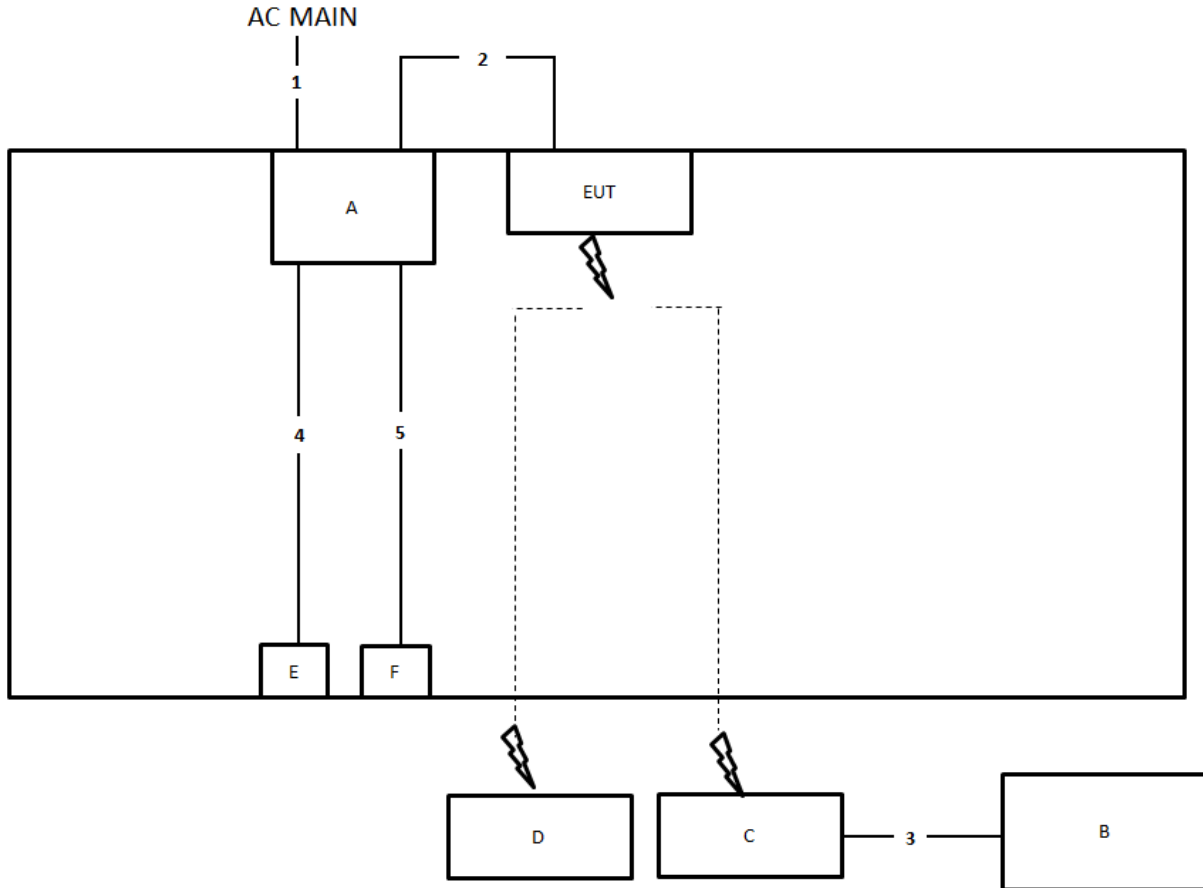

Item	Connection	Shielded	Length
1	Power cable	No	2.6m
2	USB cable	Yes	3m
3	RJ-45 cable	No	1.5m
4	Audio cable	No	1.1m
5	USB cable	Yes	1.5m

**Test Setup Diagram - Radiated Test > 1GHz**

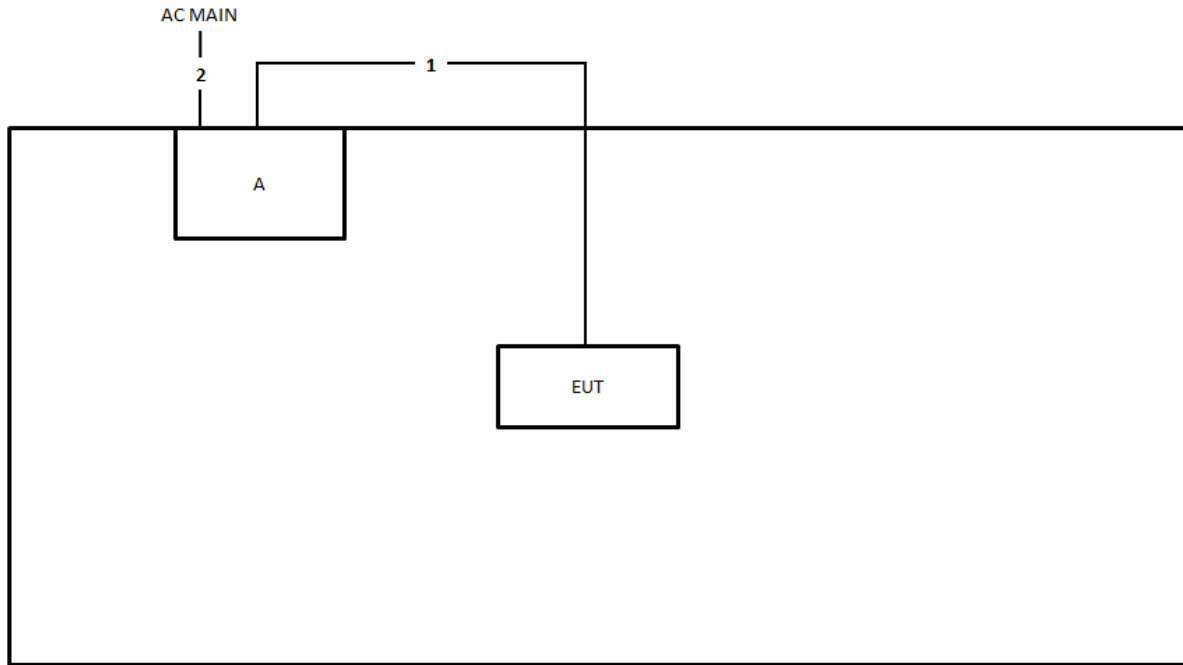

Item	Connection	Shielded	Length
1	USB cable	Yes	1m
2	Power cable	No	2.6m



### 3 Transmitter Test Result

#### 3.1 AC Power-line Conducted Emissions

##### 3.1.1 AC Power-line Conducted Emissions Limit

AC Power-line Conducted Emissions Limit		
Frequency Emission (MHz)	Quasi-Peak	Average
0.15-0.5	66 - 56 *	56 - 46 *
0.5-5	56	46
5-30	60	50

Note 1: \* Decreases with the logarithm of the frequency.

##### 3.1.2 Measuring Instruments

Refer a test equipment and calibration data table in this test report.

##### 3.1.3 Test Procedures

Test Method
▪ Refer as ANSI C63.10-2013, clause 6.2 for AC power-line conducted emissions.



**3.1.4 Test Setup**

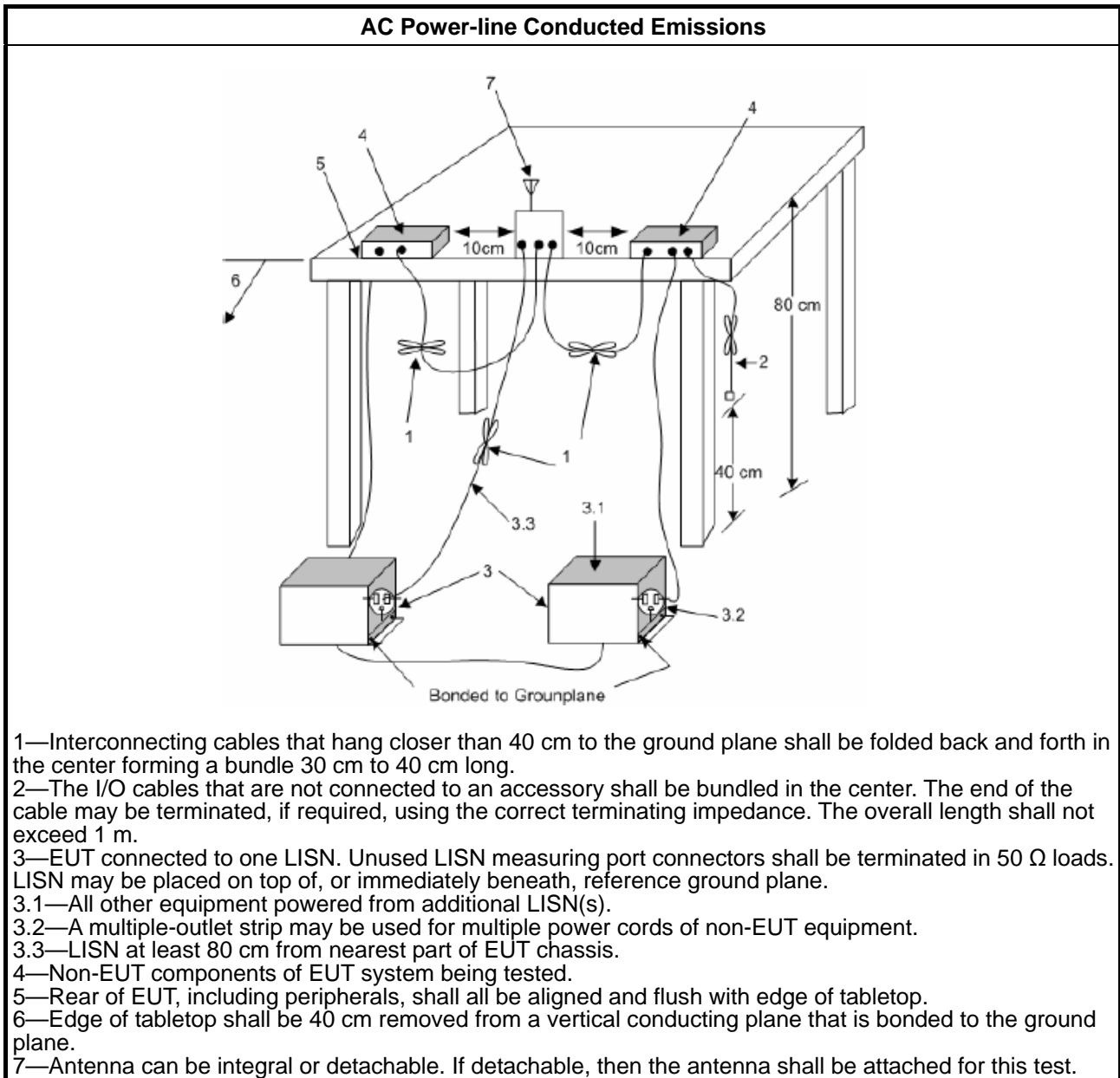

**1.1.1. Measurement Results Calculation**

The measured Level is calculated using:

- a. Corrected Reading: LISN Factor (LISN) + Attenuator (AT/AUX) + Cable Loss (CL) + Read Level (Raw) = Level
- b. Margin = -Limit + Level

**3.1.5 Test Result of AC Power-line Conducted Emissions**

Refer as Appendix A

### 3.2 DTS Bandwidth

#### 3.2.1 6dB Bandwidth Limit

6dB Bandwidth Limit
<b>Systems using digital modulation techniques:</b>
<ul style="list-style-type: none"> <li>▪ 6 dB bandwidth <math>\geq</math> 500 kHz.</li> </ul>

#### 3.2.2 Measuring Instruments

Refer a test equipment and calibration data table in this test report.

#### 3.2.3 Test Procedures

Test Method
<ul style="list-style-type: none"> <li>▪ For the emission bandwidth shall be measured using one of the options below:</li> </ul>
<input checked="" type="checkbox"/> Refer as FCC KDB 558074, clause 8.2 & C63.10 clause 11.8.1 Option 1 for 6 dB bandwidth measurement.
<input type="checkbox"/> Refer as FCC KDB 558074, clause 8.2 & C63.10 clause 11.8.2 Option 2 for 6 dB bandwidth measurement.
<input type="checkbox"/> Refer as ANSI C63.10, clause 6.9.1 for occupied bandwidth testing.

#### 3.2.4 Test Setup

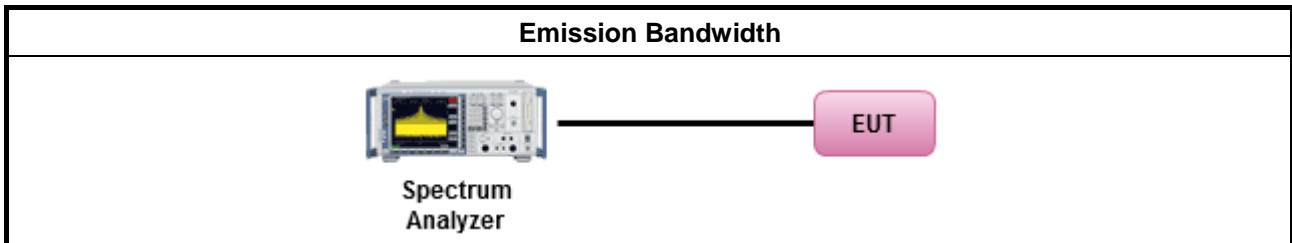

#### 3.2.5 Test Result of Emission Bandwidth

Refer as Appendix B



### 3.3 Maximum Conducted Output Power

#### 3.3.1 Maximum Conducted Output Power Limit

Maximum Conducted Output Power Limit	
	<ul style="list-style-type: none"><li>▪ If <math>G_{TX} \leq 6</math> dBi, then <math>P_{Out} \leq 30</math> dBm (1 W)</li></ul>
	<ul style="list-style-type: none"><li>▪ Point-to-multipoint systems (P2M): If <math>G_{TX} &gt; 6</math> dBi, then <math>P_{Out} = 30 - (G_{TX} - 6)</math> dBm</li></ul>
	<ul style="list-style-type: none"><li>▪ Point-to-point systems (P2P): If <math>G_{TX} &gt; 6</math> dBi, then <math>P_{Out} = 30 - (G_{TX} - 6)/3</math> dBm</li></ul>
	<ul style="list-style-type: none"><li>▪ Smart antenna system (SAS):</li></ul>
	<ul style="list-style-type: none"><li>- Single beam: If <math>G_{TX} &gt; 6</math> dBi, then <math>P_{Out} = 30 - (G_{TX} - 6)/3</math> dBm</li></ul>
	<ul style="list-style-type: none"><li>- Overlap beam: If <math>G_{TX} &gt; 6</math> dBi, then <math>P_{Out} = 30 - (G_{TX} - 6)/3</math> dBm</li></ul>
	<ul style="list-style-type: none"><li>- Aggregate power on all beams: If <math>G_{TX} &gt; 6</math> dBi, then <math>P_{Out} = 30 - (G_{TX} - 6)/3 + 8</math> dB dBm</li></ul>
$P_{Out}$ = maximum peak conducted output power or maximum conducted output power in dBm, $G_{TX}$ = the maximum transmitting antenna directional gain in dBi.	

#### 3.3.2 Measuring Instruments

Refer a test equipment and calibration data table in this test report.



3.3.3 Test Procedures

Test Method	
<ul style="list-style-type: none"> <li>▪ Maximum Peak Conducted Output Power</li> </ul>	
<input type="checkbox"/>	Refer as FCC KDB 558074, clause 8.3.1.1 & C63.10 clause 11.9.1.1 (RBW ≥ EBW method).
<input type="checkbox"/>	Refer as FCC KDB 558074, clause 8.3.1.3 & C63.10 clause 11.9.1.3 (peak power meter).
<ul style="list-style-type: none"> <li>▪ Maximum Conducted Output Power</li> </ul>	
[duty cycle ≥ 98% or external video / power trigger]	
<input type="checkbox"/>	Refer as FCC KDB 558074, clause 8.3.2.2 & C63.10 clause 11.9.2.2.2 Method AVGSA-1.
<input type="checkbox"/>	Refer as FCC KDB 558074, clause 8.3.2.2 & C63.10 clause 11.9.2.2.3 Method AVGSA-1A. (alternative)
duty cycle < 98% and average over on/off periods with duty factor	
<input type="checkbox"/>	Refer as FCC KDB 558074, clause 8.3.2.2 & C63.10 clause 11.9.2.2.4 Method AVGSA-2.
<input type="checkbox"/>	Refer as FCC KDB 558074, clause 8.3.2.2 & C63.10 clause 11.9.2.2.5 Method AVGSA-2A (alternative)
<input type="checkbox"/>	Refer as FCC KDB 558074, clause 8.3.2.2 & C63.10 clause 11.9.2.2.6 Method AVGSA-3
<input type="checkbox"/>	Refer as FCC KDB 558074, clause 8.3.2.2 & C63.10 clause 11.9.2.2.7 Method AVGSA-3A (alternative)
Measurement using a power meter (PM)	
<input type="checkbox"/>	Refer as FCC KDB 558074, clause 8.3.2.3 & C63.10 clause 11.9.2.3.1 Method AVGPM (using an RF average power meter).
<input checked="" type="checkbox"/>	Refer as FCC KDB 558074, clause 8.3.2.3 & C63.10 clause 11.9.2.3.2 Method AVGPM-G (using an gate RF average power meter).
<ul style="list-style-type: none"> <li>▪ For conducted measurement.</li> </ul>	
<ul style="list-style-type: none"> <li>▪ If the EUT supports multiple transmit chains using options given below: Refer as FCC KDB 662911, In-band power measurements. Using the measure-and-sum approach, measured all transmit ports individually. Sum the power (in linear power units e.g., mW) of all ports for each individual sample and save them.</li> </ul>	
<ul style="list-style-type: none"> <li>▪ If multiple transmit chains, EIRP calculation could be following as methods:  <math display="block">P_{total} = P_1 + P_2 + \dots + P_n</math> (calculated in linear unit [mW] and transfer to log unit [dBm])  <math display="block">EIRP_{total} = P_{total} + DG</math> </li> </ul>	

### 3.3.4 Test Setup

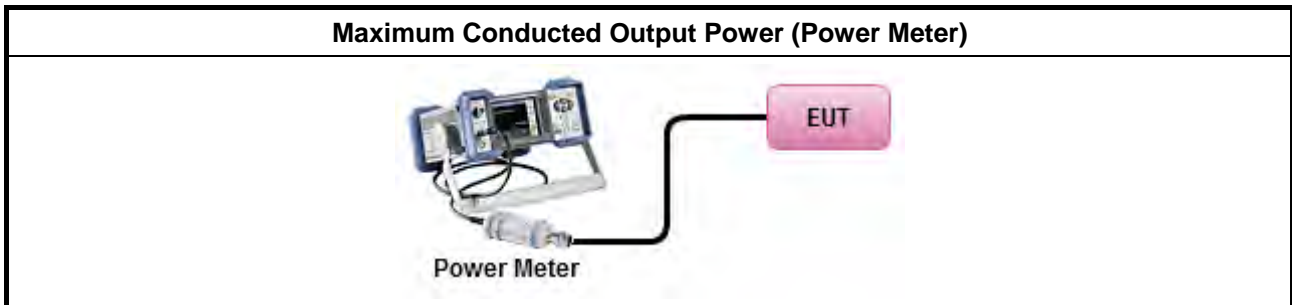

### 3.3.5 Test Result of Maximum Conducted Output Power

Refer as Appendix C



### 3.4 Power Spectral Density

#### 3.4.1 Power Spectral Density Limit

Power Spectral Density Limit
<ul style="list-style-type: none"> <li>Power Spectral Density (PSD) ≤ 8 dBm/3kHz</li> </ul>

#### 3.4.2 Measuring Instruments

Refer a test equipment and calibration data table in this test report.

#### 3.4.3 Test Procedures

Test Method
<ul style="list-style-type: none"> <li>Peak power spectral density procedures that the same method as used to determine the conducted output power. If maximum peak conducted output power was measured to demonstrate compliance to the output power limit, then the peak PSD procedure below (Method PKPSD) shall be used. If maximum conducted output power was measured to demonstrate compliance to the output power limit, then one of the average PSD procedures shall be used, as applicable based on the following criteria (the peak PSD procedure is also an acceptable option).</li> </ul>
<input checked="" type="checkbox"/> Refer as FCC KDB 558074, clause 8.4 & C63.10 clause 11.10 Method Max. PSD. [duty cycle ≥ 98% or external video / power trigger]
<ul style="list-style-type: none"> <li>For conducted measurement.</li> </ul>
<ul style="list-style-type: none"> <li>If The EUT supports multiple transmit chains using options given below: <ul style="list-style-type: none"> <li><input type="checkbox"/> Option 1: Measure and sum the spectra across the outputs. Refer as FCC KDB 662911, In-band power spectral density (PSD). Sample all transmit ports simultaneously using a spectrum analyzer for each transmit port. Where the trace bin-by-bin of each transmit port summing can be performed. (i.e., in the first spectral bin of output 1 is summed with that in the first spectral bin of output 2 and that from the first spectral bin of output 3, and so on up to the NTX output to obtain the value for the first frequency bin of the summed spectrum.). Add up the amplitude (power) values for the different transmit chains and use this as the new data trace.</li> <li><input type="checkbox"/> Option 2: Measure and sum spectral maxima across the outputs. With this technique, spectra are measured at each output of the device at the required resolution bandwidth. The maximum value (peak) of each spectrum is determined. These maximum values are then summed mathematically in linear power units across the outputs. These operations shall be performed separately over frequency spans that have different out-of-band or spurious emission limits,</li> <li><input type="checkbox"/> Option 3: Measure and add 10 log(N) dB, where N is the number of transmit chains. Refer as FCC KDB 662911, In-band power spectral density (PSD). Performed at each transmit chains and each transmit chains shall be compared with the limit have been reduced with 10 log(N). Or each transmit chains shall be add 10 log(N) to compared with the limit.</li> </ul> </li> </ul>

### 3.4.4 Test Setup

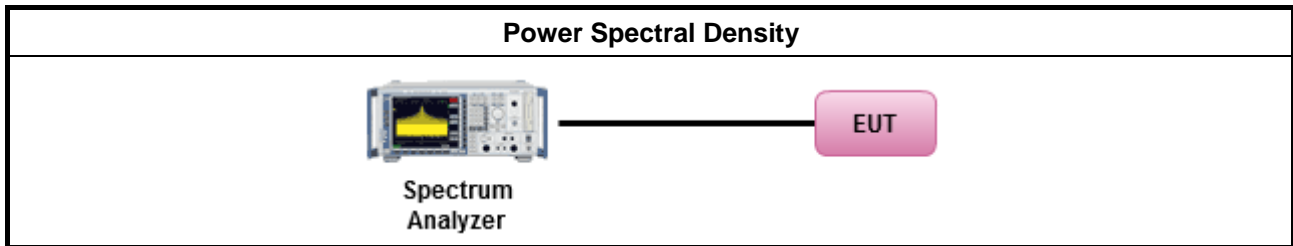

### 3.4.5 Test Result of Power Spectral Density

Refer as Appendix D

### 3.5 Emissions in Non-restricted Frequency Bands

#### 3.5.1 Emissions in Non-restricted Frequency Bands Limit

Un-restricted Band Emissions Limit	
RF output power procedure	Limit (dBc)
Peak output power procedure	20
Average output power procedure	30

Note 1: If the peak output power procedure is used to measure the fundamental emission power to demonstrate compliance to requirements, then the peak conducted output power measured within any 100 kHz outside the authorized frequency band shall be attenuated by at least 20 dB relative to the maximum measured in-band peak PSD level.

Note 2: If the average output power procedure is used to measure the fundamental emission power to demonstrate compliance to requirements, then the power in any 100 kHz outside of the authorized frequency band shall be attenuated by at least 30 dB relative to the maximum measured in-band average PSD level.

#### 3.5.2 Measuring Instruments

Refer a test equipment and calibration data table in this test report.

#### 3.5.3 Test Procedures

Test Method
<ul style="list-style-type: none"> <li>Refer as FCC KDB 558074, clause 8.5 for unwanted emissions into non-restricted bands.</li> </ul>

#### 3.5.4 Test Setup

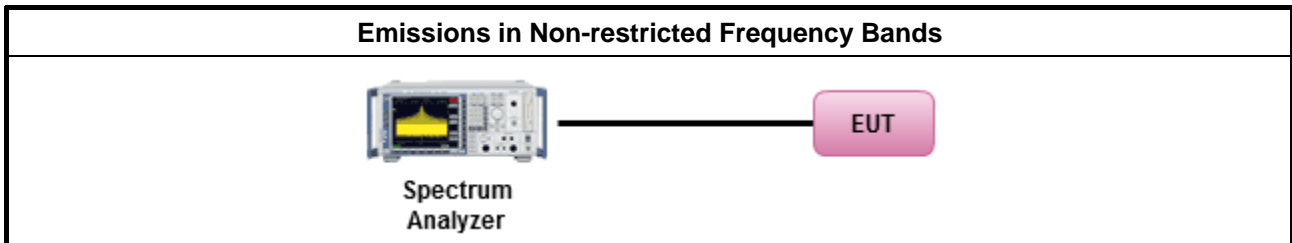

#### 3.5.5 Test Result of Emissions in Non-restricted Frequency Bands

Refer as Appendix E





### 3.6 Emissions in Restricted Frequency Bands

#### 3.6.1 Emissions in Restricted Frequency Bands Limit

Restricted Band Emissions Limit			
Frequency Range (MHz)	Field Strength (uV/m)	Field Strength (dBuV/m)	Measure Distance (m)
0.009~0.490	2400/F(kHz)	48.5 - 13.8	300
0.490~1.705	24000/F(kHz)	33.8 - 23	30
1.705~30.0	30	29	30
30~88	100	40	3
88~216	150	43.5	3
216~960	200	46	3
Above 960	500	54	3

Note 1: Test distance for frequencies at or above 30 MHz, measurements may be performed at a distance other than the limit distance provided they are not performed in the near field and the emissions to be measured can be detected by the measurement equipment. When performing measurements at a distance other than that specified, the results shall be extrapolated to the specified distance using an extrapolation factor of 20 dB/decade (inverse of linear distance for field-strength measurements, inverse of linear distance-squared for power-density measurements).

Note 2: Test distance for frequencies at below 30 MHz, measurements may be performed at a distance closer than the EUT limit distance; however, an attempt should be made to avoid making measurements in the near field. When performing measurements below 30 MHz at a closer distance than the limit distance, the results shall be extrapolated to the specified distance by either making measurements at a minimum of two or more distances on at least one radial to determine the proper extrapolation factor or by using the square of an inverse linear distance extrapolation factor (40 dB / decade). The test report shall specify the extrapolation method used to determine compliance of the EUT.

Note 3: Using the distance of 1m during the test for above 18 GHz, and the test value to correct for the distance factor at 3m.

#### 3.6.2 Measuring Instruments

Refer a test equipment and calibration data table in this test report.



**3.6.3 Test Procedures**

<b>Test Method</b>	
<ul style="list-style-type: none"> <li>▪ The average emission levels shall be measured in [duty cycle <math>\geq</math> 98 or duty factor].</li> </ul>	
<ul style="list-style-type: none"> <li>▪ Refer as ANSI C63.10, clause 6.10.3 band-edge testing shall be performed at the lowest frequency channel and highest frequency channel within the allowed operating band.</li> </ul>	
<ul style="list-style-type: none"> <li>▪ For the transmitter unwanted emissions shall be measured using following options below:</li> </ul>	
	<ul style="list-style-type: none"> <li>▪ Refer as FCC KDB 558074, clause 8.6 for unwanted emissions into restricted bands.</li> </ul>
	<input type="checkbox"/> Refer as FCC KDB 558074, clause 8.6 & C63.10 clause 11.12.2.5.1(trace averaging for duty cycle $\geq$ 98%).
	<input type="checkbox"/> Refer as FCC KDB 558074, clause 8.6 & C63.10 clause 11.12.2.5.2(trace averaging + duty factor).
	<input checked="" type="checkbox"/> Refer as FCC KDB 558074, clause 8.6 & C63.10 clause 11.12.2.5.3(Reduced VBW $\geq$ 1/T).
	<input type="checkbox"/> Refer as ANSI C63.10, clause 11.12.2.5.3 (Reduced VBW). VBW $\geq$ 1/T, where T is pulse time.
	<input type="checkbox"/> Refer as ANSI C63.10, clause 7.5 average value of pulsed emissions.
	<input checked="" type="checkbox"/> Refer as FCC KDB 558074, clause 8.6 & C63.10 clause 11.12.2.4 measurement procedure peak limit.
<ul style="list-style-type: none"> <li>▪ For the transmitter band-edge emissions shall be measured using following options below:</li> </ul>	
	<ul style="list-style-type: none"> <li>▪ Refer as FCC KDB 558074 clause 8.7 &amp; c63.10 clause 11.13.1, When the performing peak or average radiated measurements, emissions within 2 MHz of the authorized band edge may be measured using the marker-delta method described below.</li> </ul>
	<ul style="list-style-type: none"> <li>▪ Refer as FCC KDB 558074, clause 8.7 (ANSI C63.10, clause 6.10.6) for marker-delta method for band-edge measurements.</li> </ul>
	<ul style="list-style-type: none"> <li>▪ Refer as FCC KDB 558074, clause 8.7 for narrower resolution bandwidth (100kHz) using the band power and summing the spectral levels (i.e., 1 MHz).</li> </ul>
	<ul style="list-style-type: none"> <li>▪ For conducted unwanted emissions into restricted bands (absolute emission limits). Devices with multiple transmit chains using options given below: (1) Measure and sum the spectra across the outputs or (2) Measure and add 10 log(N) dB</li> </ul>
	<ul style="list-style-type: none"> <li>▪ For FCC KDB 662911 The methodology described here may overestimate array gain, thereby resulting in apparent failures to satisfy the out-of-band limits even if the device is actually compliant. In such cases, compliance may be demonstrated by performing radiated tests around the frequencies at which the apparent failures occurred.</li> </ul>

**3.6.4 Test Setup**

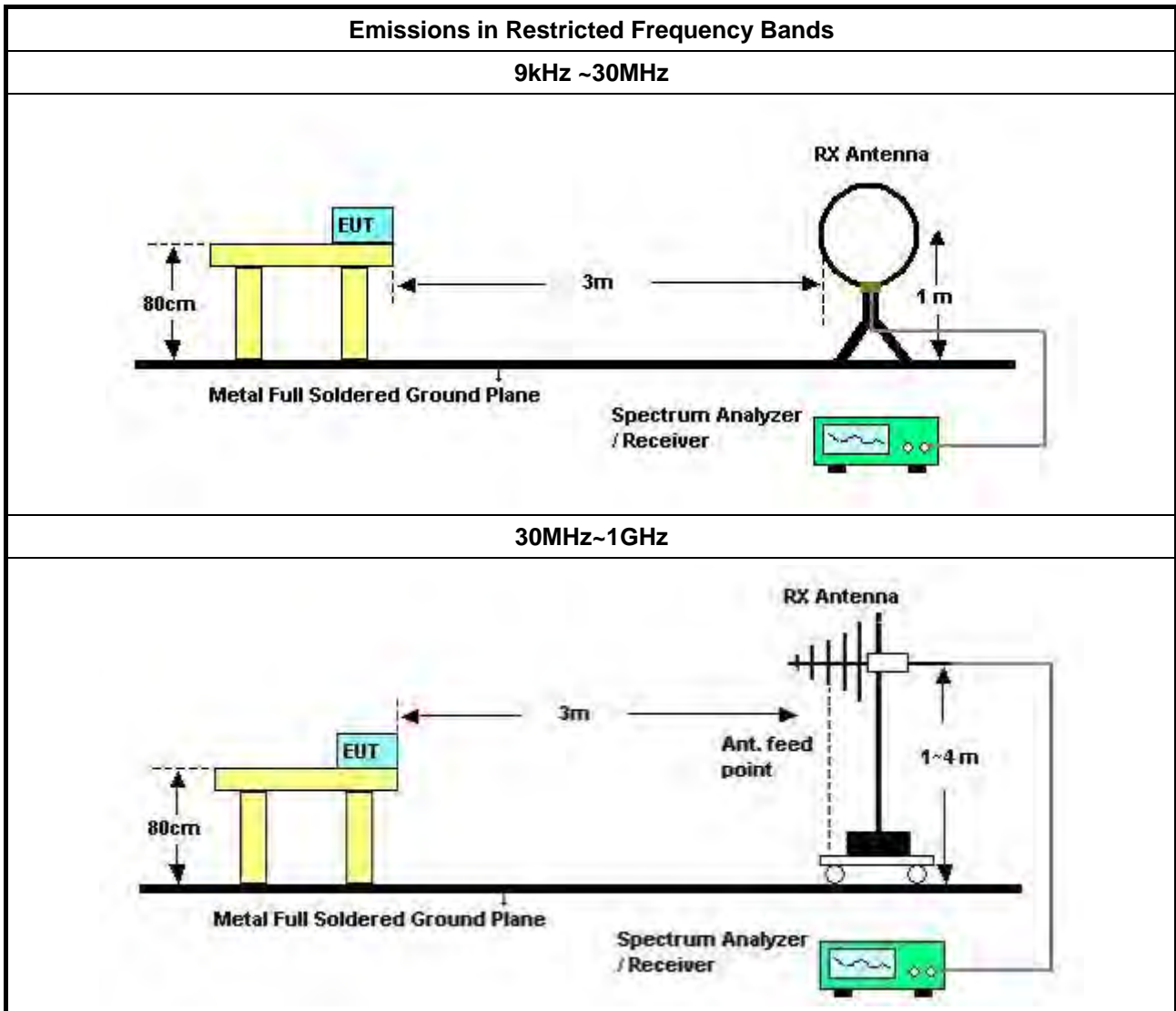

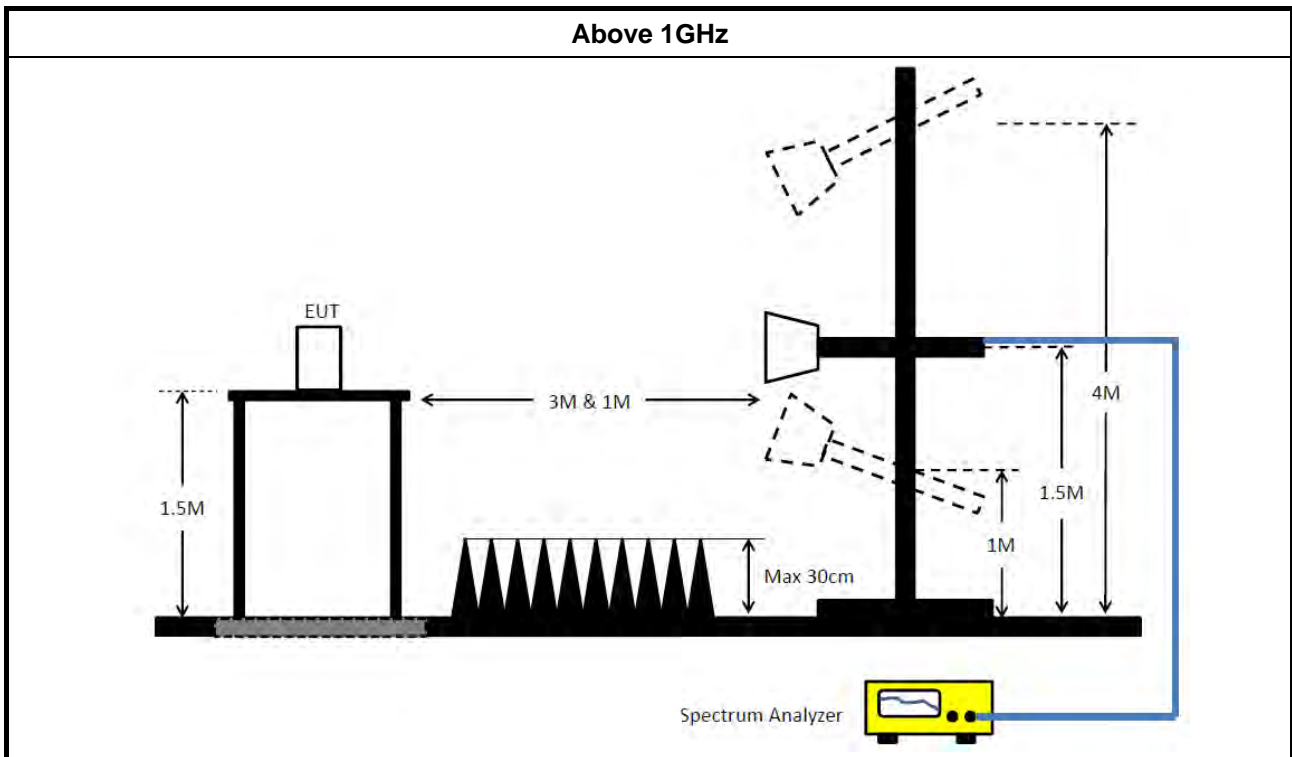

### 3.6.5 Measurement Results Calculation

The measured Level is calculated using:

Corrected Reading: Antenna factor (AF) + Cable loss (CL) + Read level (Raw) - Preamp factor (PA)(if applicable) = Level.

### 3.6.6 Emissions in Restricted Frequency Bands (Below 30MHz)

There is a comparison data of both open-field test site and alternative test site - semi-Anechoic chamber according to KDB414788 Radiated Test Site, and the result came out very similar.

All amplitude of spurious emissions that are attenuated by more than 20 dB below the permissible value has no need to be reported.

The radiated emissions were investigated from 9 kHz or the lowest frequency generated within the device, up to the 10th harmonic or 40 GHz, whichever is appropriate.

### 3.6.7 Test Result of Emissions in Restricted Frequency Bands

Refer as Appendix F



## 4 Test Equipment and Calibration Data

Instrument	Brand	Model No.	Serial No.	Characteristics	Calibration Date	Calibration Due Date	Remark
LISN	Schwarzbeck	NSLK 8127	8127650	9kHz ~ 30MHz	Dec. 04, 2020	Dec. 03, 2021	Conduction (CO02-CB)
LISN	Schwarzbeck	NSLK 8127	8127478	9kHz ~ 30MHz	Nov. 20, 2020	Nov. 19, 2021	Conduction (CO02-CB)
EMI Receiver	Agilent	N9038A	MY52260140	9kHz ~ 8.4GHz	Mar. 10, 2020	Mar. 09, 2021	Conduction (CO02-CB)
COND Cable	Woken	Cable	2	0.15MHz~30MHz	Oct. 20, 2020	Oct. 19, 2021	Conduction (CO02-CB)
Software	SPORTON	SENSE	V5.10	-	N.C.R.	N.C.R.	Conduction (CO02-CB)
Pulse Limiter	Schwarzbeck	VTSD 9561F-N	00378	9kHz ~ 30MHz	Mar. 19, 2020	Mar. 18, 2021	Conduction (CO02-CB)
Loop Antenna	Teseq	HLA 6120	24155	9kHz - 30 MHz	Apr. 13, 2020	Apr. 12, 2021	Radiation (03CH05-CB)
3m Semi Anechoic Chamber NSA	TDK	SAC-3M	03CH05-CB	30 MHz ~ 1 GHz	Aug. 10, 2020	Aug. 09, 2021	Radiation (03CH05-CB)
Bilog Antenna with 6dB Attenuator	TESEQ & EMCI	CBL 6112D & N-6-06	35236 & AT-N0610	30MHz ~ 2GHz	Mar. 26, 2021	Mar. 25, 2022	Radiation (03CH05-CB)
Pre-Amplifier	EMCI	EMC330N	980331	20MHz ~ 3GHz	Apr. 28, 2020	Apr. 27, 2021	Radiation (03CH05-CB)
Spectrum Analyzer	R&S	FSP40	100304	9kHz ~ 40GHz	Nov. 10, 2020	Nov. 09, 2021	Radiation (03CH05-CB)
EMI Test Receiver	R&S	ESCS	826547/017	9kHz ~ 2.75GHz	May 13, 2020	May 12, 2021	Radiation (03CH05-CB)
RF Cable-low	Woken	RG402	Low Cable-04+23	30MHz~1GHz	Oct. 05, 2020	Oct. 04, 2021	Radiation (03CH05-CB)
Test Software	SPORTON	SENSE	V5.10	-	N.C.R.	N.C.R.	Radiation (03CH05-CB)
3m Semi Anechoic Chamber VSWR	TDK	SAC-3M	03CH01-CB	1GHz ~18GHz 3m	May 29, 2020	May 28, 2021	Radiation (03CH01-CB)
Horn Antenna	ETS-LINDGR EN	3115	00075790	750MHz ~ 18GHz	Nov. 06, 2020	Nov. 05, 2021	Radiation (03CH01-CB)
Horn Antenna	Schwarzbeck	BBHA 9170	BBHA9170252	15GHz ~ 40GHz	Jul. 21, 2020	Jul. 20, 2021	Radiation (03CH01-CB)
Pre-Amplifier	Agilent	8449B	3008A02310	1GHz ~ 26.5GHz	Jan. 07, 2021	Jan. 06, 2022	Radiation (03CH01-CB)
Pre-Amplifier	MITEQ	TTA1840-35-HG	1864479	18GHz ~ 40GHz	Jul. 08, 2020	Jul. 07, 2021	Radiation (03CH01-CB)
Spectrum Analyzer	R&S	FSP40	100056	9kHz ~ 40GHz	Apr. 16, 2020	Apr. 15, 2021	Radiation (03CH01-CB)
RF Cable-high	Woken	RG402	High Cable-16	1 GHz ~ 18 GHz	Oct. 05, 2020	Oct. 04, 2021	Radiation (03CH01-CB)



Instrument	Brand	Model No.	Serial No.	Characteristics	Calibration Date	Calibration Due Date	Remark
RF Cable-high	Woken	RG402	High Cable-16+17	1 GHz ~ 18 GHz	Oct. 05, 2020	Oct. 04, 2021	Radiation (03CH01-CB)
RF Cable-high	Woken	RG402	High Cable-40G#1	18GHz ~ 40 GHz	Jul. 16, 2020	Jul. 15, 2021	Radiation (03CH01-CB)
RF Cable-high	Woken	RG402	High Cable-40G#2	18GHz ~ 40 GHz	Jul. 16, 2020	Jul. 15, 2021	Radiation (03CH01-CB)
Test Software	SPORTON	SENSE	V5.10	-	N.C.R.	N.C.R.	Radiation (03CH01-CB)
Spectrum analyzer	R&S	FSV40	101028	9kHz~40GHz	Dec. 31, 2020	Dec. 30, 2021	Conducted (TH03-CB)
Power Sensor	Anritsu	MA2411B	1726195	300MHz~40GHz	Aug. 17, 2020	Aug. 16, 2021	Conducted (TH03-CB)
Power Meter	Anritsu	ML2495A	1035008	300MHz~40GHz	Aug. 17, 2020	Aug. 16, 2021	Conducted (TH03-CB)
RF Cable-high	Woken	RG402	High Cable-11	1 GHz ~18 GHz	Oct. 05, 2020	Oct. 04, 2021	Conducted (TH03-CB)
RF Cable-high	Woken	RG402	High Cable-12	1 GHz ~18 GHz	Oct. 05, 2020	Oct. 04, 2021	Conducted (TH03-CB)
RF Cable-high	Woken	RG402	High Cable-13	1 GHz ~18 GHz	Oct. 05, 2020	Oct. 04, 2021	Conducted (TH03-CB)
RF Cable-high	Woken	RG402	High Cable-14	1 GHz ~18 GHz	Oct. 05, 2020	Oct. 04, 2021	Conducted (TH03-CB)
RF Cable-high	Woken	RG402	High Cable-15	1 GHz ~18 GHz	Oct. 05, 2020	Oct. 04, 2021	Conducted (TH03-CB)
Test Software	SPORTON	SENSE	V5.10	-	N.C.R.	N.C.R.	Conducted (TH03-CB)

Note: Calibration Interval of instruments listed above is one year.

N.C.R. means Non-Calibration required.



**Summary**

Mode	Result	Type	Freq (Hz)	Level (dBuV)	Limit (dBuV)	Margin (dB)	Condition
Mode 2	Pass	AV	11.76M	38.89	50.00	-11.11	Line

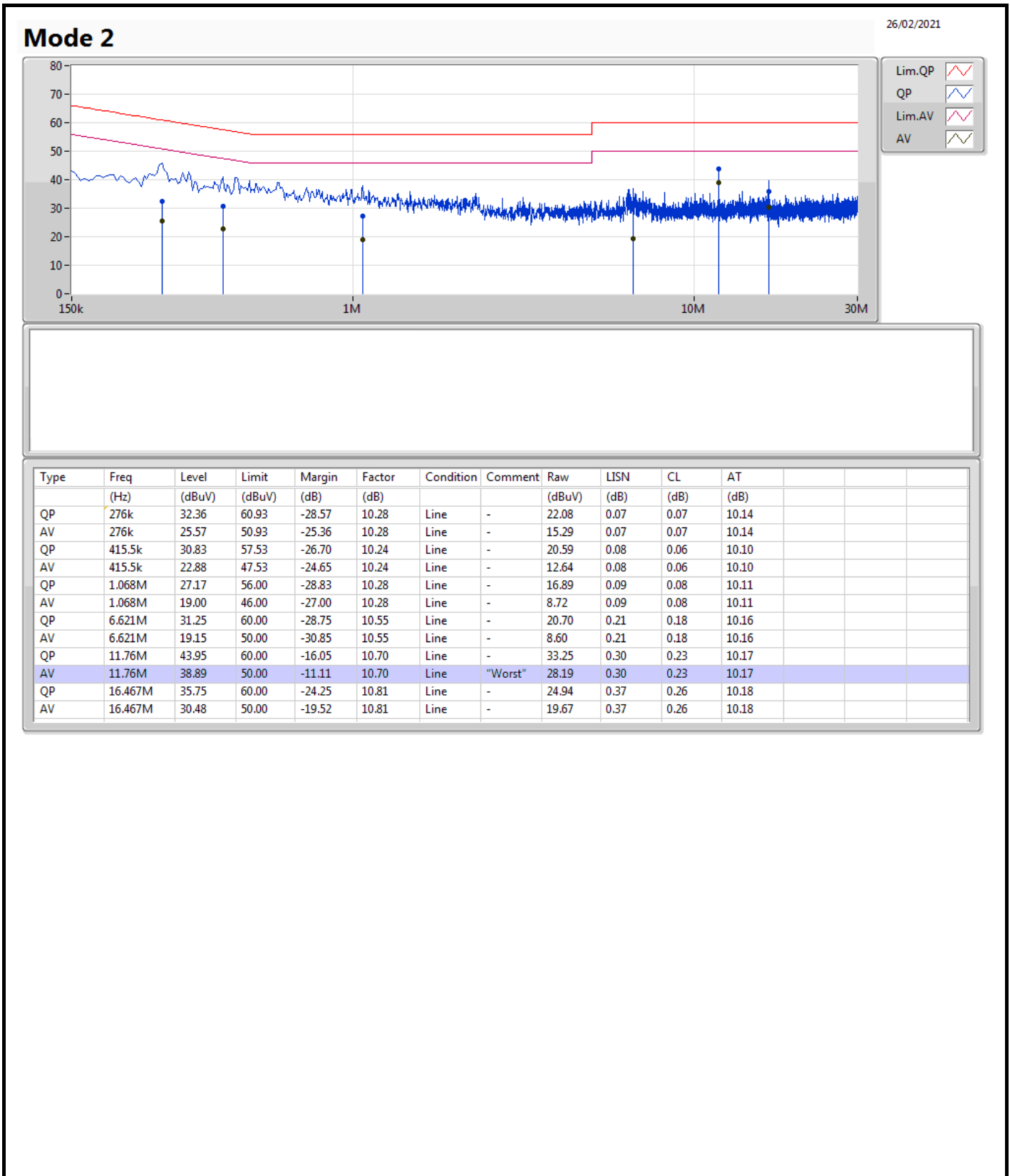



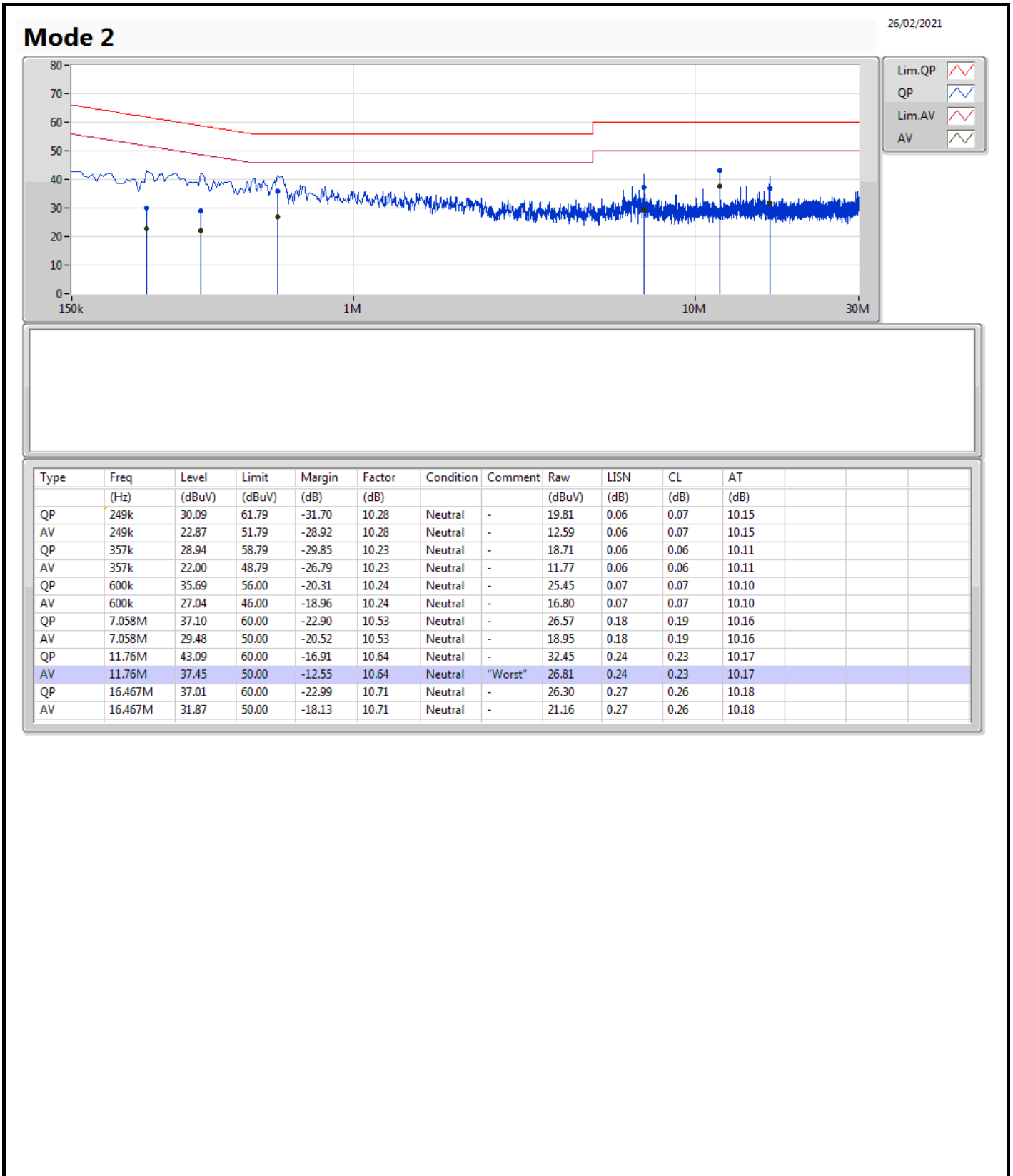



Summary

Mode	Max-N dB (Hz)	Max-OBW (Hz)	ITU-Code	Min-N dB (Hz)	Min-OBW (Hz)
2.4-2.4835GHz	-	-	-	-	-
BT-LE(1Mbps)	672.5k	1.057M	1M06F1D	670k	1.057M

**Max-N dB** = Maximum 6dB down bandwidth; **Max-OBW** = Maximum 99% occupied bandwidth;  
**Min-N dB** = Minimum 6dB down bandwidth; **Min-OBW** = Minimum 99% occupied bandwidth;

**Result**

Mode	Result	Limit (Hz)	Port 1-N dB (Hz)	Port 1-OBW (Hz)
BT-LE(1Mbps)	-	-	-	-
2402MHz	Pass	500k	670k	1.057M
2440MHz	Pass	500k	671.25k	1.057M
2480MHz	Pass	500k	672.5k	1.057M

**Port X-N dB** = Port X 6dB down bandwidth; **Port X-OBW** = Port X 99% occupied bandwidth;

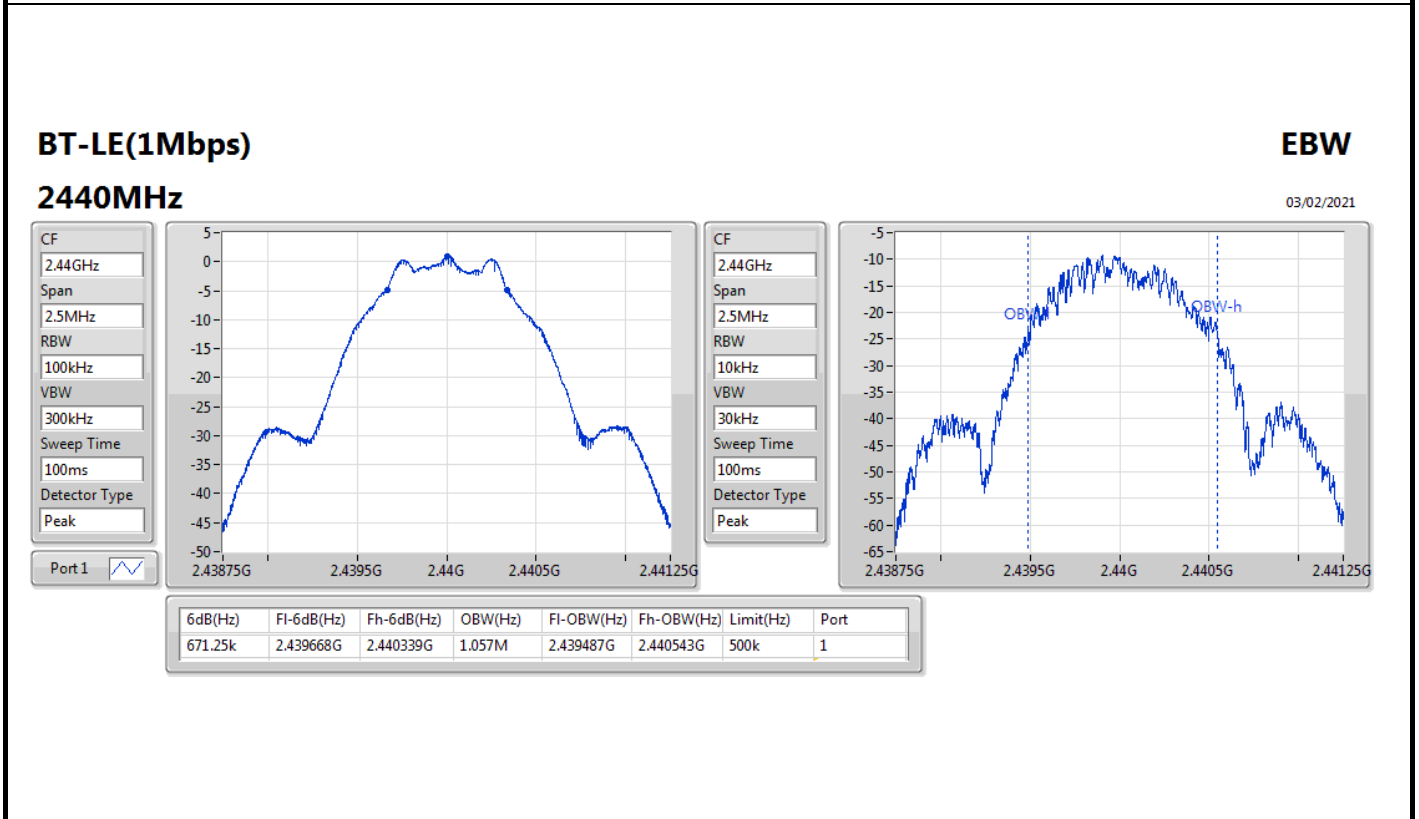
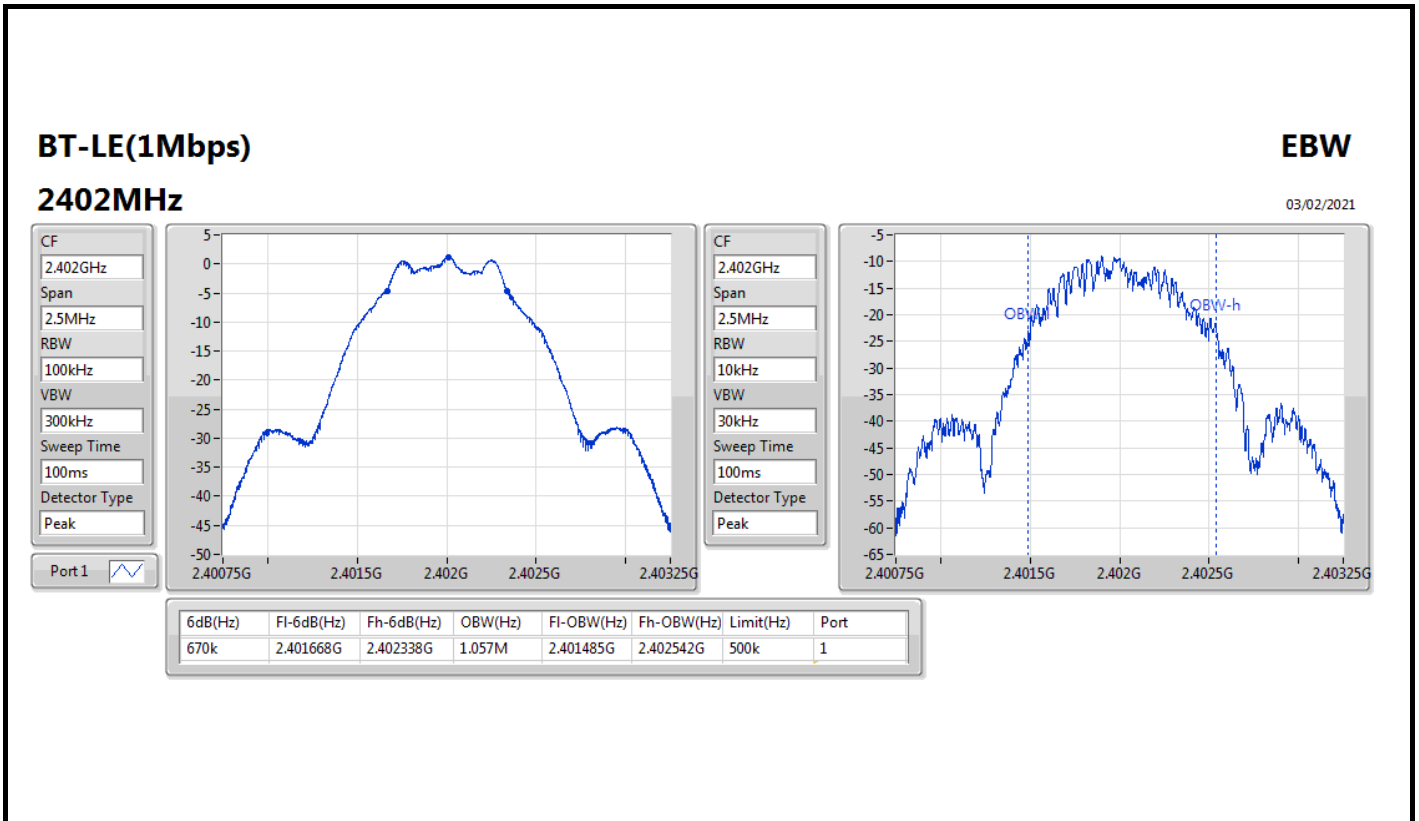

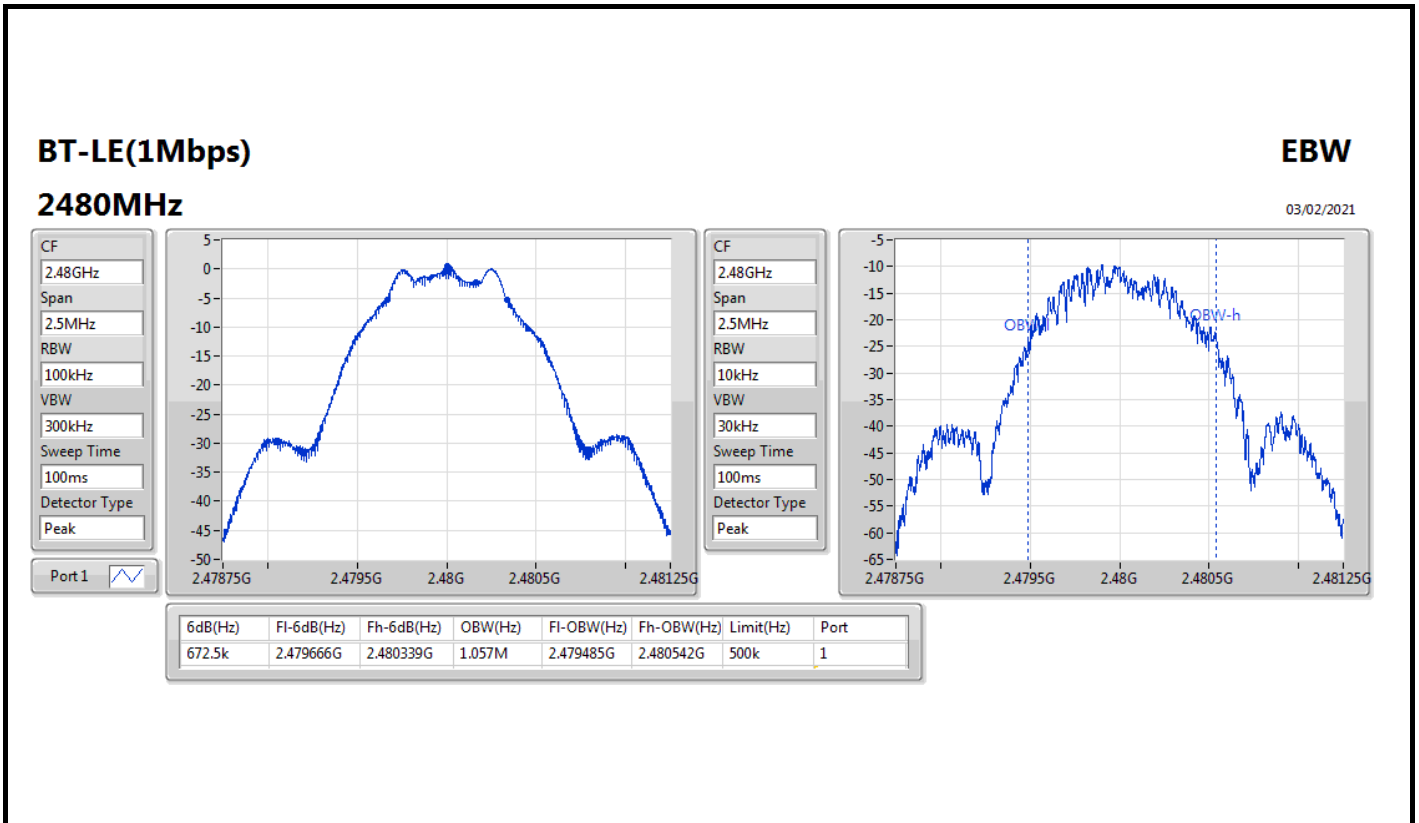



**Summary**

Mode	Power (dBm)	Power (W)
2.4-2.4835GHz	-	-
BT-LE(1Mbps)	1.01	0.00126



**Result**

Mode	Result	Gain (dBi)	Power (dBm)	Power Limit (dBm)
BT-LE(1Mbps)	-	-	-	-
2402MHz	Pass	2.68	0.90	30.00
2440MHz	Pass	2.68	1.01	30.00
2480MHz	Pass	2.68	0.53	30.00

**DG** = Directional Gain; **Port X** = Port X output power



Summary

Mode	PD (dBm/RBW)
2.4-2.4835GHz	-
BT-LE(1Mbps)	-13.77

RBW=3 kHz.





Result

Mode	Result	Gain (dBi)	PD (dBm/RBW)	PD Limit (dBm/RBW)
BT-LE(1Mbps)	-	-	-	-
2402MHz	Pass	2.68	-13.77	8.00
2440MHz	Pass	2.68	-14.57	8.00
2480MHz	Pass	2.68	-14.34	8.00

DG = Directional Gain; RBW=3 kHz;

PD = trace bin-by-bin of each transmits port summing can be performed maximum power density; Port X = Port X power density;

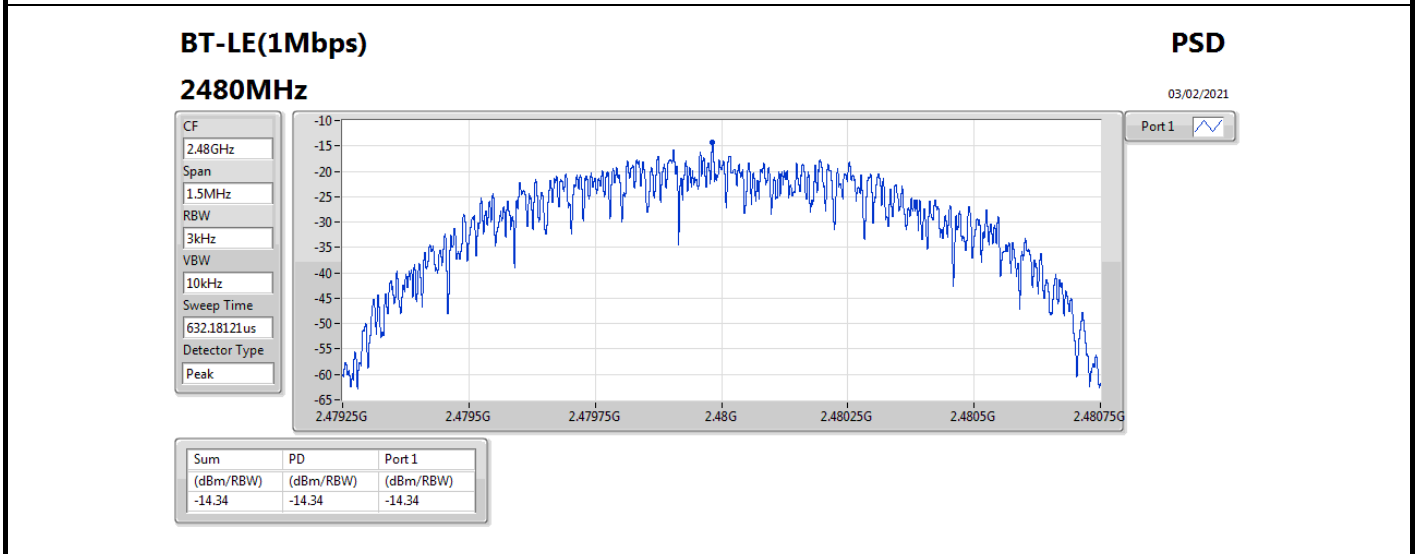
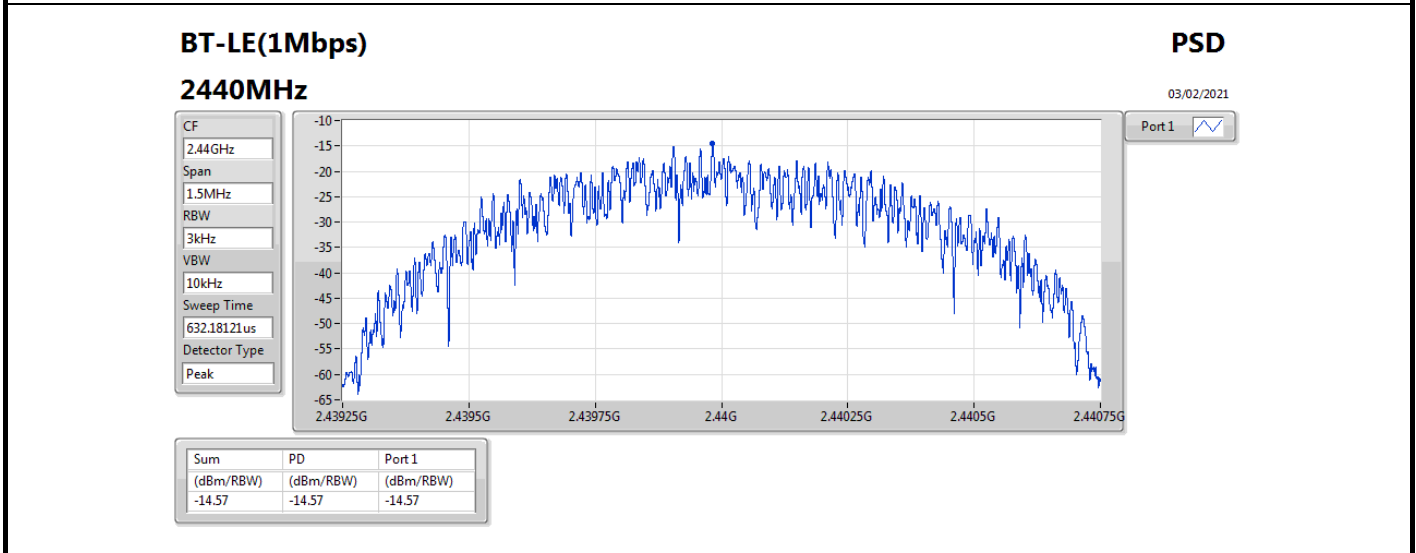
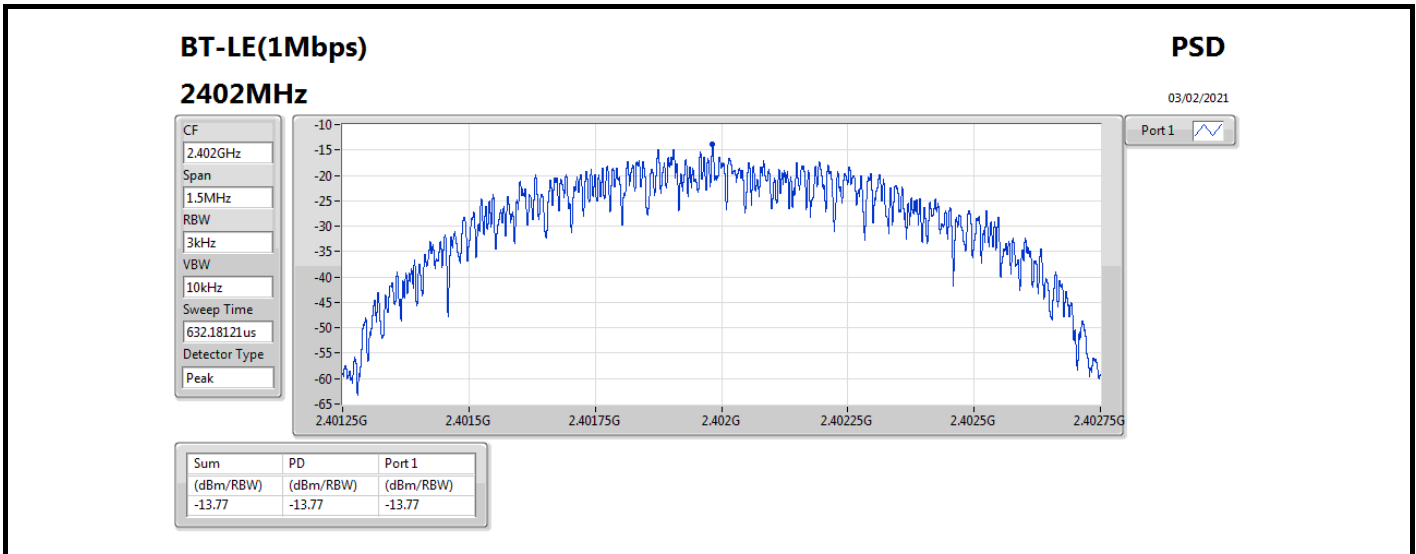



Summary

Mode	Result	Ref (Hz)	Ref (dBm)	Limit (dBm)	Freq (Hz)	Level (dBm)	Freq (Hz)	Level (dBm)	Freq (Hz)	Level (dBm)	Freq (Hz)	Level (dBm)	Freq (Hz)	Level (dBm)	Port
2.4-2.4835GHz	-	-	-	-	-	-	-	-	-	-	-	-	-	-	-
BT-LE(1Mbps)	Pass	2.44004G	0.77	-29.23	223.88M	-49.80	2.39714G	-51.78	2.4835G	-53.58	2.49097G	-51.52	16.20668G	-46.24	1



Result

Mode	Result	Ref (Hz)	Ref (dBm)	Limit (dBm)	Freq (Hz)	Level (dBm)	Freq (Hz)	Level (dBm)	Freq (Hz)	Level (dBm)	Freq (Hz)	Level (dBm)	Freq (Hz)	Level (dBm)	Port
BT-LE(1Mbps)	-	-	-	-	-	-	-	-	-	-	-	-	-	-	-
2402MHz	Pass	2.44004G	0.77	-29.23	544.06M	-51.81	2.39954G	-52.35	2.4G	-53.54	2.50137G	-52.10	16.35853G	-46.28	1
2440MHz	Pass	2.44004G	0.77	-29.23	735.88M	-52.79	2.39112G	-52.42	2.4G	-55.95	2.49071G	-51.88	15.14372G	-46.69	1
2480MHz	Pass	2.44004G	0.77	-29.23	223.88M	-49.80	2.39714G	-51.78	2.4835G	-53.58	2.49097G	-51.52	16.20668G	-46.24	1

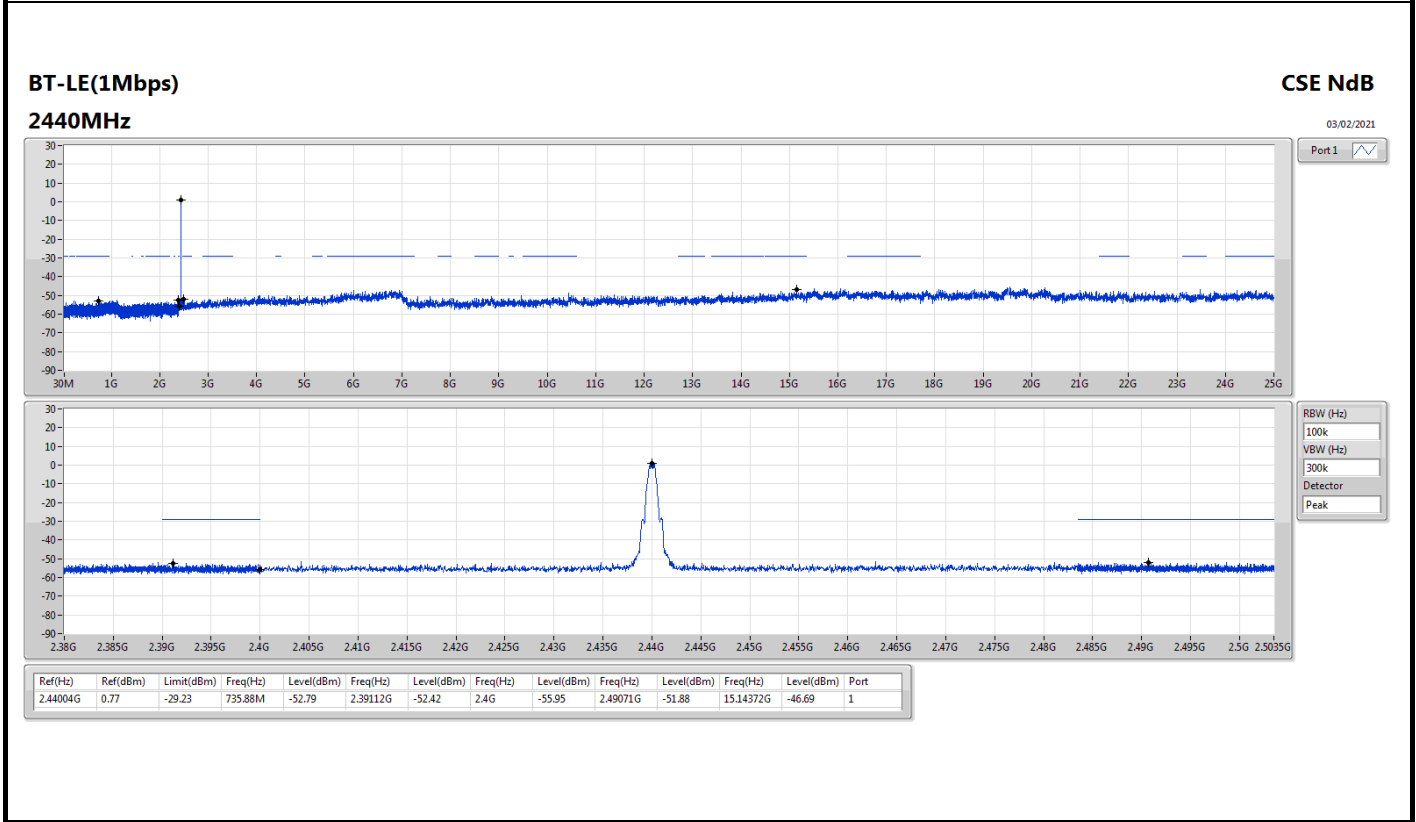
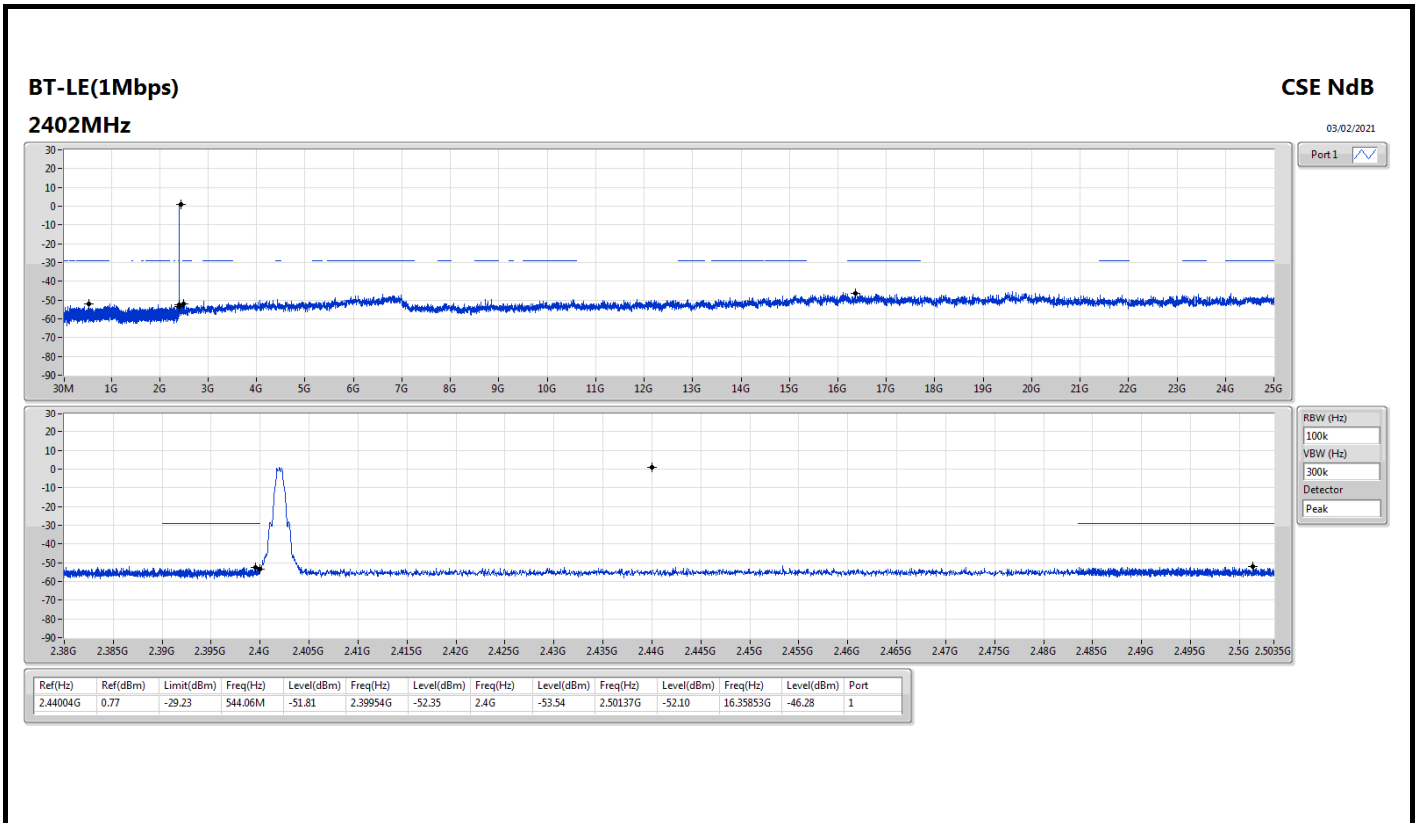

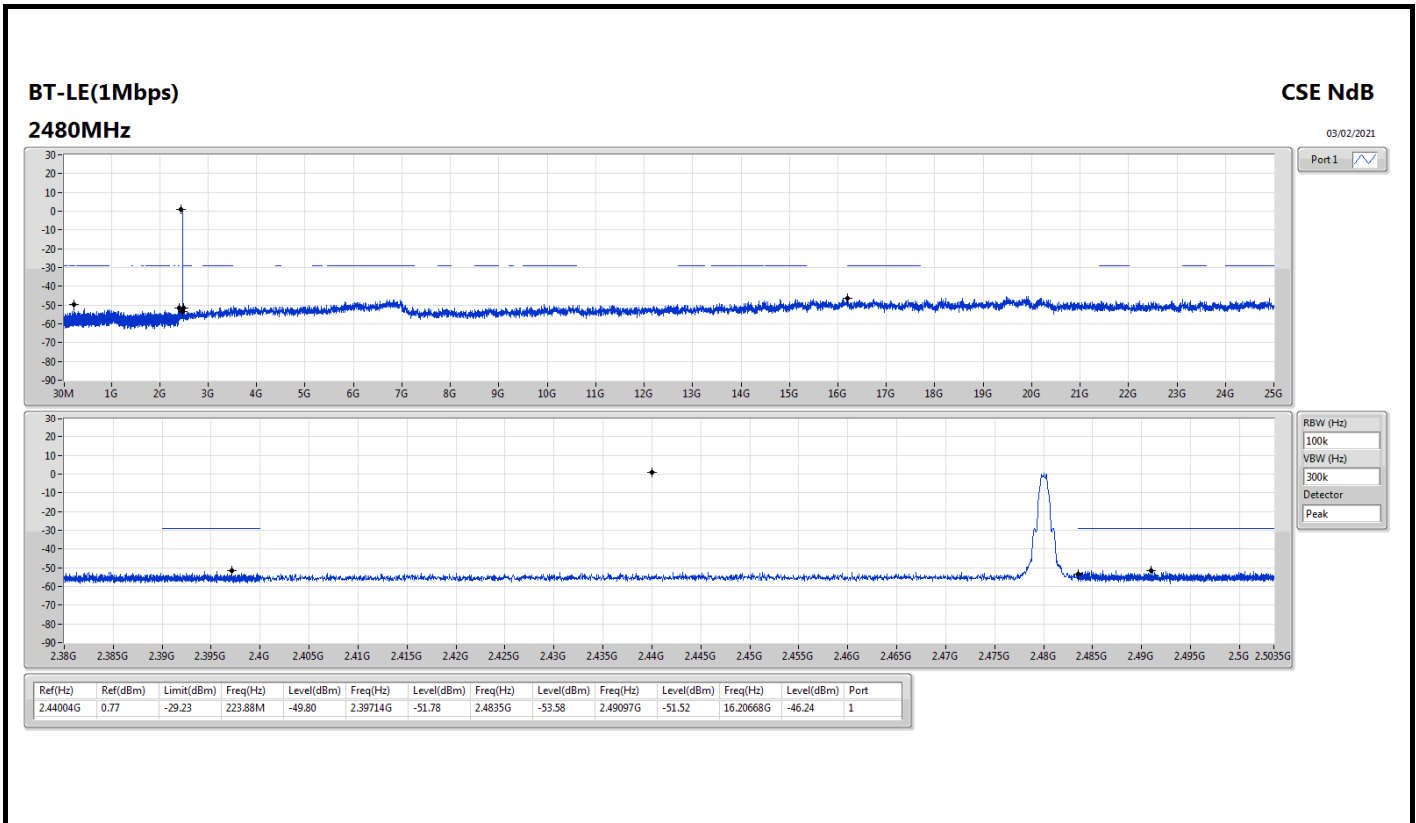



**Summary**

Mode	Result	Type	Freq (Hz)	Level (dBuV/m)	Limit (dBuV/m)	Margin (dB)	Condition
Mode 4	Pass	PK	149.31M	39.45	43.50	-4.05	Vertical

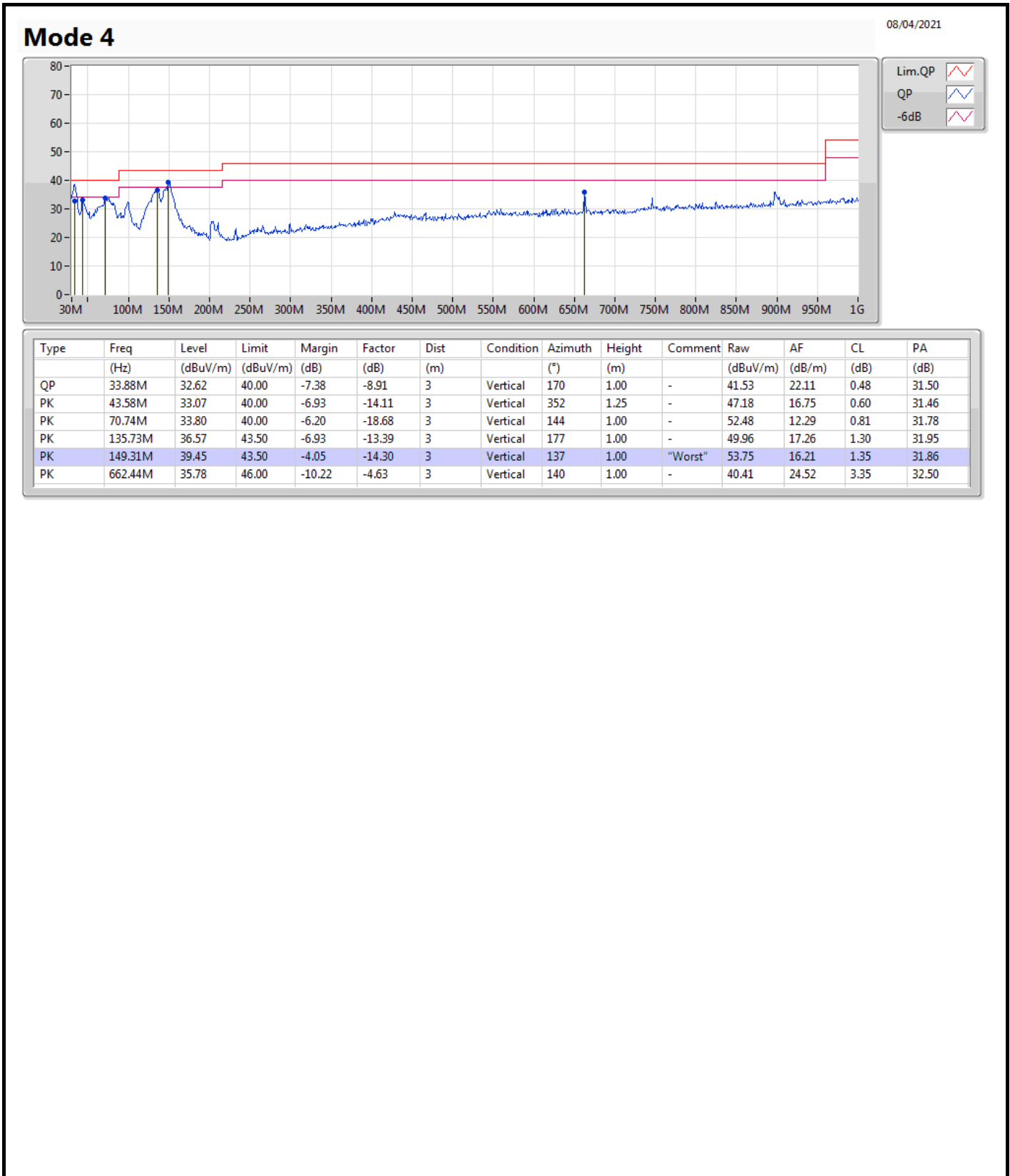



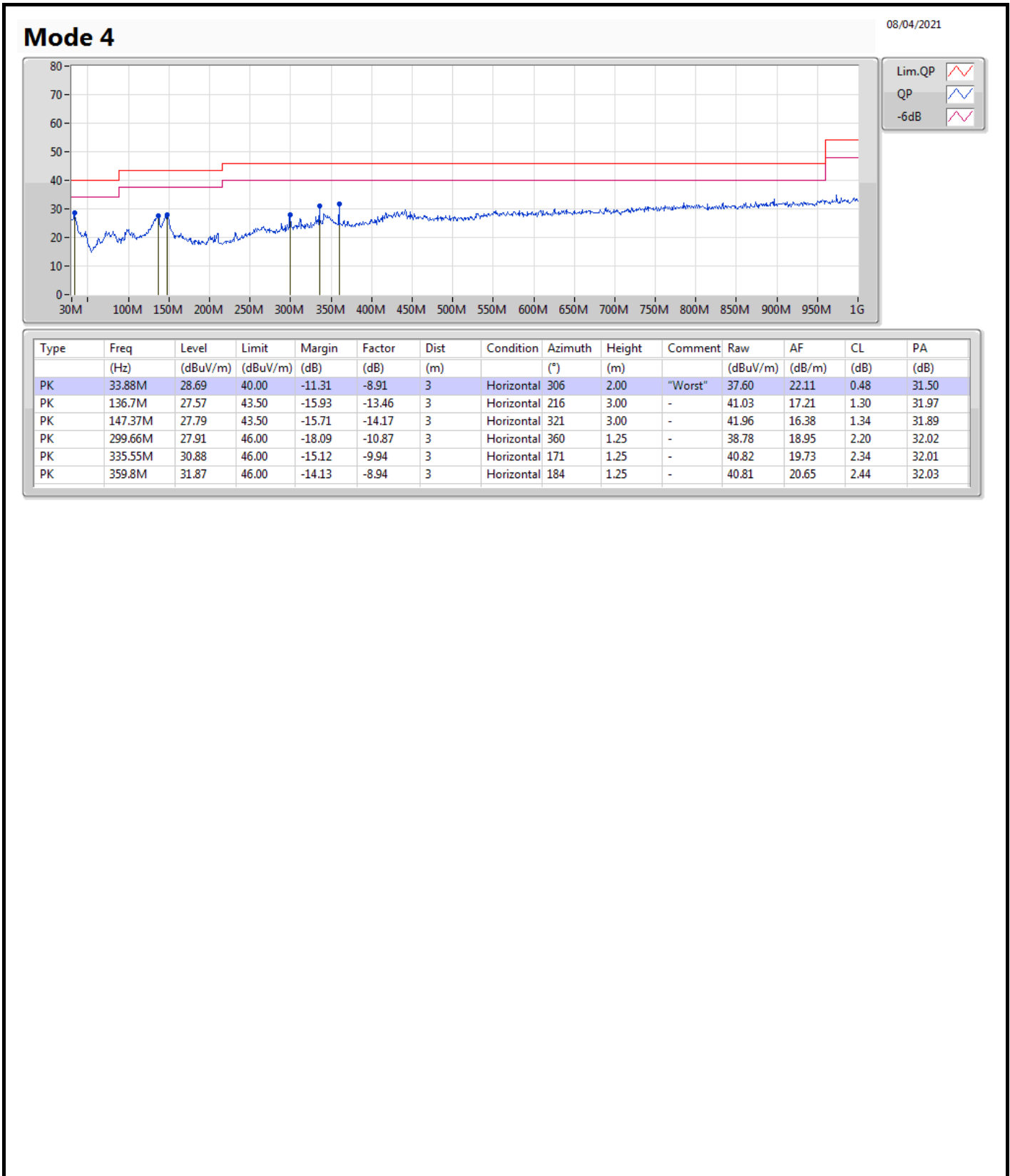



Summary





Mode	Result	Type	Freq (Hz)	Level (dBuV/m)	Limit (dBuV/m)	Margin (dB)	Dist (m)	Condition	Azimuth (°)	Height (m)	Comments
2.4-2.4835GHz	-	-	-	-	-	-	-	-	-	-	-
BT-LE(1Mbps)	Pass	AV	2.4835G	41.92	54.00	-12.08	3	Horizontal	33	1.03	-

**BT-LE(1Mbps)**

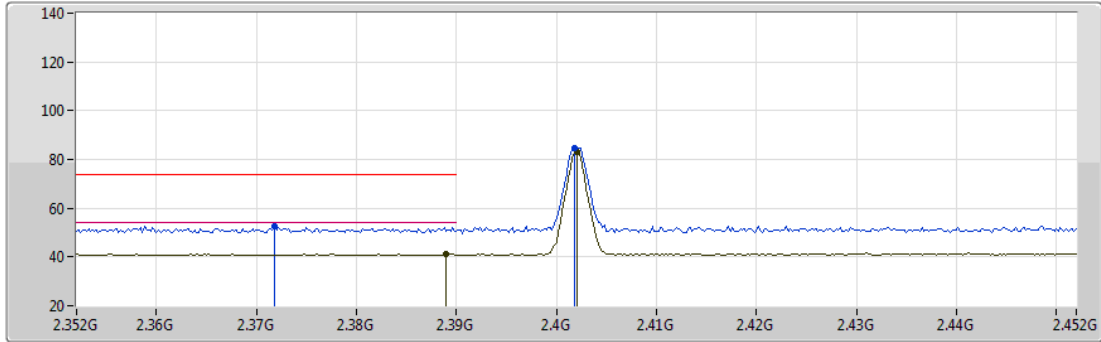
01/02/2021

**2402MHz\_TX**



Lim.PK   
 PK   
 Lim.AV   
 AV 

EUT Z\_1TX  
 Setting Default  
 01-A-B-4

Type	Freq (Hz)	Level (dBuV/m)	Limit (dBuV/m)	Margin (dB)	Raw (dBuV)	Dist (m)	Condition	Azimuth (°)	Height (m)	Comment	AF (dB)	CL (dB)	PA (dB)
PK	2.3718G	52.55	74.00	-21.45	23.04	3	Vertical	346	1.62	-	27.34	2.17	-
AV	2.389G	41.20	54.00	-12.80	11.63	3	Vertical	346	1.62	-	27.38	2.19	-
PK	2.4018G	84.62	Inf	-Inf	55.02	3	Vertical	346	1.62	-	27.40	2.20	-
AV	2.402G	83.04	Inf	-Inf	53.44	3	Vertical	346	1.62	-	27.40	2.20	-

**BT-LE(1Mbps)**

01/02/2021

**2402MHz\_TX**

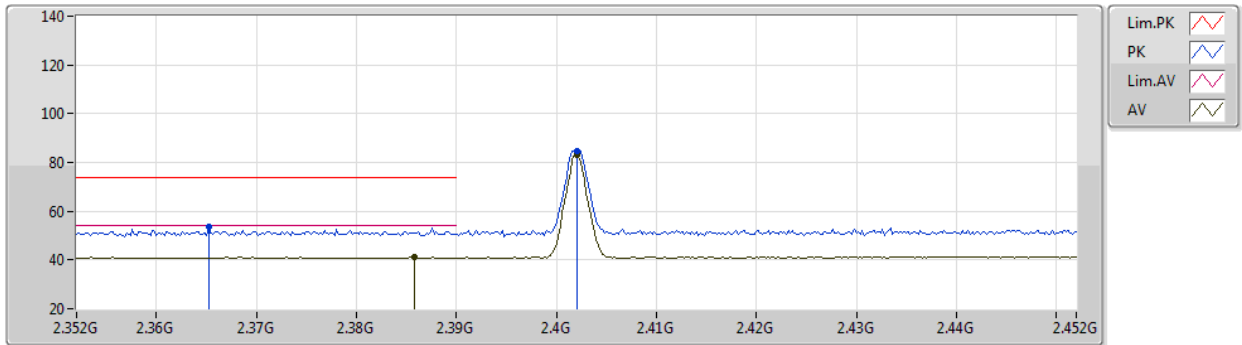

EUT Z\_1TX  
Setting Default  
01-A-B-4

Type	Freq (Hz)	Level (dBuV/m)	Limit (dBuV/m)	Margin (dB)	Raw (dBuV)	Dist (m)	Condition	Azimuth (°)	Height (m)	Comment	AF (dB)	CL (dB)	PA (dB)
PK	2.3652G	53.41	74.00	-20.59	23.91	3	Horizontal	0	1.36	-	27.33	2.17	-
AV	2.3858G	41.17	54.00	-12.83	11.61	3	Horizontal	0	1.36	-	27.37	2.19	-
PK	2.402G	84.73	Inf	-Inf	55.13	3	Horizontal	0	1.36	-	27.40	2.20	-
AV	2.402G	83.24	Inf	-Inf	53.64	3	Horizontal	0	1.36	-	27.40	2.20	-

**BT-LE(1Mbps)**

01/02/2021

**2402MHz\_TX**

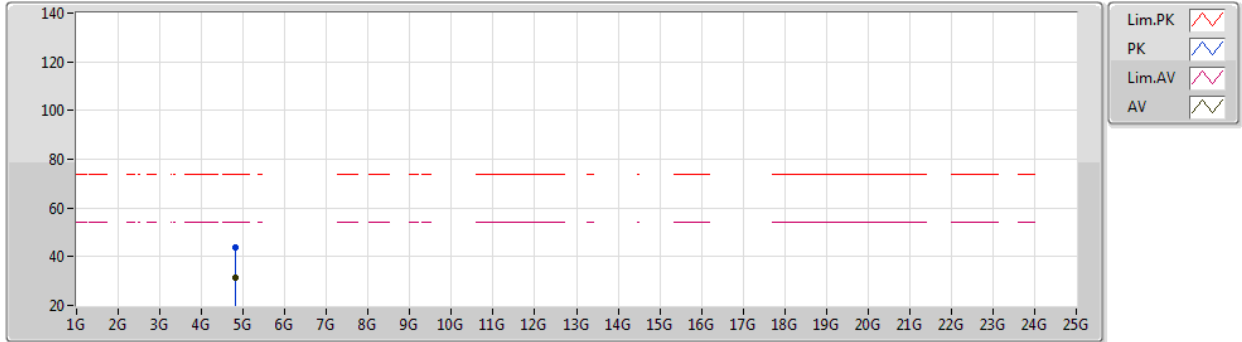

EUT Z\_1TX  
Setting Default  
01-A-B-4

Type	Freq (Hz)	Level (dBuV/m)	Limit (dBuV/m)	Margin (dB)	Raw (dBuV)	Dist (m)	Condition	Azimuth (°)	Height (m)	Comment	AF (dB)	CL (dB)	PA (dB)
PK	4.80726G	43.54	74.00	-30.46	40.95	3	Vertical	305	1.50	-	32.14	5.00	34.55
AV	4.80394G	31.41	54.00	-22.59	28.85	3	Vertical	305	1.50	-	32.12	5.00	34.56

**BT-LE(1Mbps)**

01/02/2021

**2402MHz\_TX**

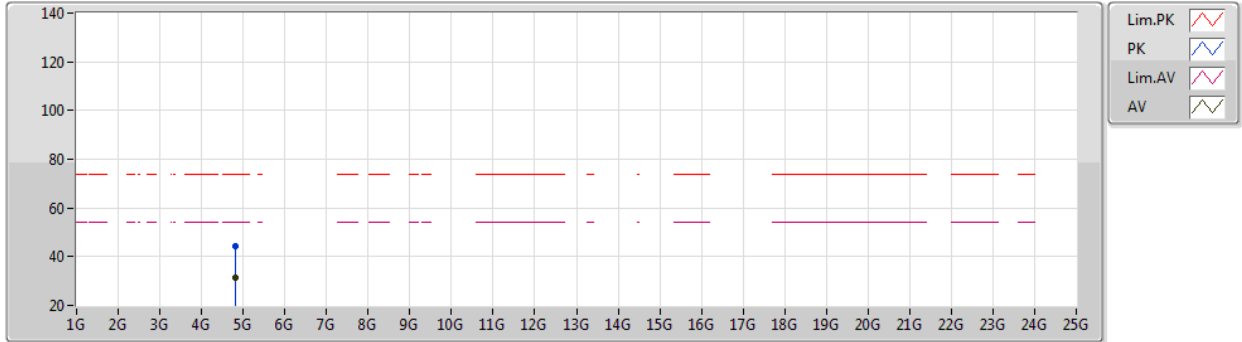

EUT Z\_1TX  
Setting Default  
01-A-B-4

Type	Freq (Hz)	Level (dBuV/m)	Limit (dBuV/m)	Margin (dB)	Raw (dBuV)	Dist (m)	Condition	Azimuth (°)	Height (m)	Comment	AF (dB)	CL (dB)	PA (dB)
PK	4.80382G	44.15	74.00	-29.85	41.59	3	Horizontal	297	2.13	-	32.12	5.00	34.56
AV	4.80346G	31.54	54.00	-22.46	28.98	3	Horizontal	297	2.13	-	32.12	5.00	34.56

**BT-LE(1Mbps)**

01/02/2021

**2440MHz\_TX**

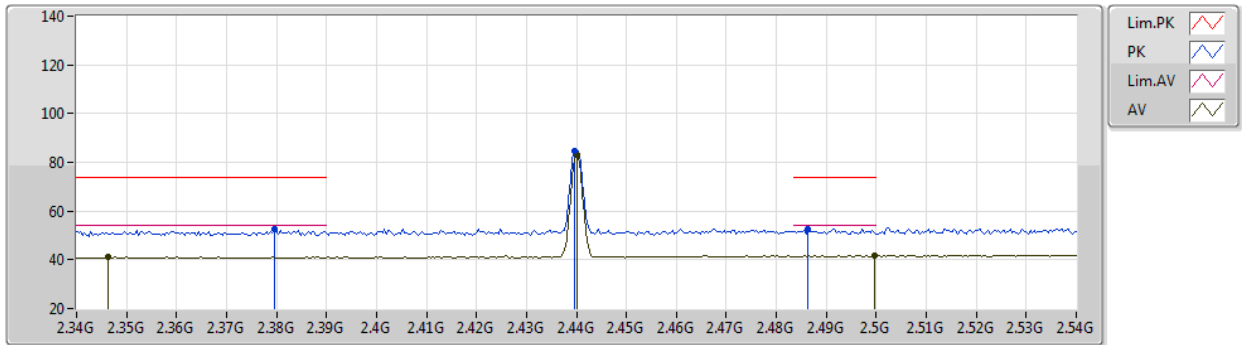

EUT Z\_1TX  
Setting Default  
01-A-B-4

Type	Freq (Hz)	Level (dBuV/m)	Limit (dBuV/m)	Margin (dB)	Raw (dBuV)	Dist (m)	Condition	Azimuth (°)	Height (m)	Comment	AF (dB)	CL (dB)	PA (dB)
PK	2.3796G	52.34	74.00	-21.66	22.80	3	Vertical	338	1.80	-	27.36	2.18	-
AV	2.3464G	41.14	54.00	-12.86	11.69	3	Vertical	338	1.80	-	27.30	2.15	-
PK	2.4396G	84.71	Inf	-Inf	54.99	3	Vertical	338	1.80	-	27.48	2.24	-
AV	2.44G	83.21	Inf	-Inf	53.49	3	Vertical	338	1.80	-	27.48	2.24	-
PK	2.4864G	52.84	74.00	-21.16	22.83	3	Vertical	338	1.80	-	27.72	2.29	-
AV	2.4996G	41.74	54.00	-12.26	11.64	3	Vertical	338	1.80	-	27.80	2.30	-

**BT-LE(1Mbps)**

01/02/2021

**2440MHz\_TX**

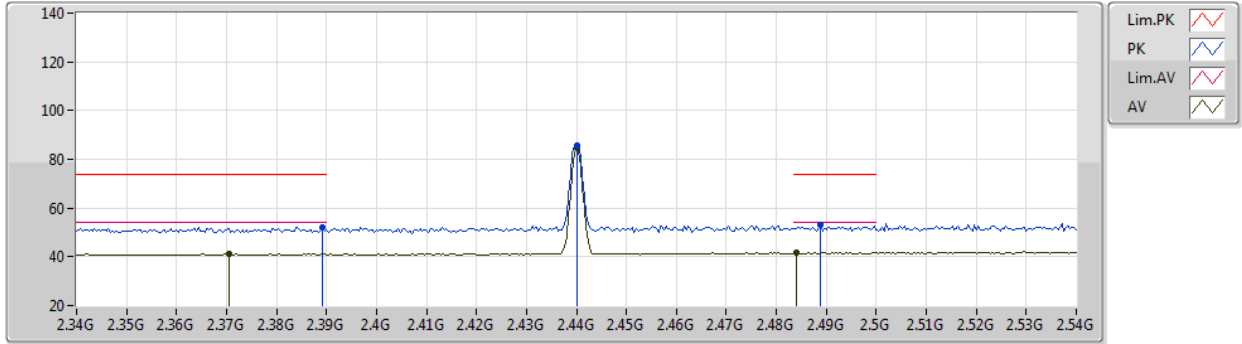

EUT Z\_1TX  
Setting Default  
01-A-B-4

Type	Freq (Hz)	Level (dBuV/m)	Limit (dBuV/m)	Margin (dB)	Raw (dBuV)	Dist (m)	Condition	Azimuth (°)	Height (m)	Comment	AF (dB)	CL (dB)	PA (dB)
PK	2.3892G	52.26	74.00	-21.74	22.69	3	Horizontal	33	1.14	-	27.38	2.19	-
AV	2.3704G	41.16	54.00	-12.84	11.65	3	Horizontal	33	1.14	-	27.34	2.17	-
PK	2.44G	85.94	Inf	-Inf	56.22	3	Horizontal	33	1.14	-	27.48	2.24	-
AV	2.44G	84.44	Inf	-Inf	54.72	3	Horizontal	33	1.14	-	27.48	2.24	-
PK	2.4888G	53.30	74.00	-20.70	23.28	3	Horizontal	33	1.14	-	27.73	2.29	-
AV	2.484G	41.60	54.00	-12.40	11.62	3	Horizontal	33	1.14	-	27.70	2.28	-



**BT-LE(1Mbps)**

01/02/2021

**2440MHz\_TX**

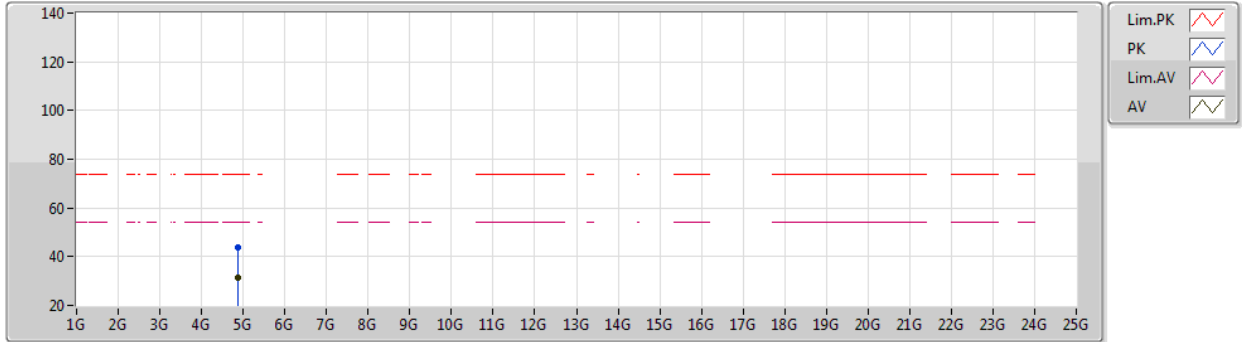

EUT Z\_1TX  
Setting Default  
01-A-B-4

Type	Freq (Hz)	Level (dBuV/m)	Limit (dBuV/m)	Margin (dB)	Raw (dBuV)	Dist (m)	Condition	Azimuth (°)	Height (m)	Comment	AF (dB)	CL (dB)	PA (dB)
PK	4.8814G	43.66	74.00	-30.34	40.68	3	Vertical	46	1.41	-	32.46	5.04	34.52
AV	4.87996G	31.23	54.00	-22.77	28.25	3	Vertical	46	1.41	-	32.46	5.04	34.52

**BT-LE(1Mbps)**

01/02/2021

**2440MHz\_TX**

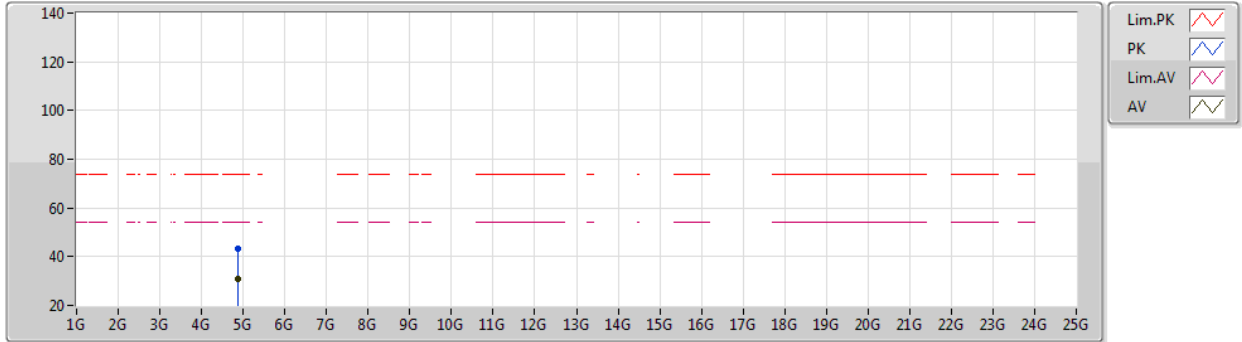

EUT Z\_1TX  
Setting Default  
01-A-B-4

Type	Freq (Hz)	Level (dBuV/m)	Limit (dBuV/m)	Margin (dB)	Raw (dBuV)	Dist (m)	Condition	Azimuth (°)	Height (m)	Comment	AF (dB)	CL (dB)	PA (dB)
PK	4.88384G	43.35	74.00	-30.65	40.36	3	Horizontal	235	2.41	-	32.47	5.04	34.52
AV	4.88398G	30.87	54.00	-23.13	27.88	3	Horizontal	235	2.41	-	32.47	5.04	34.52

**BT-LE(1Mbps)**

01/02/2021

**2480MHz\_TX**

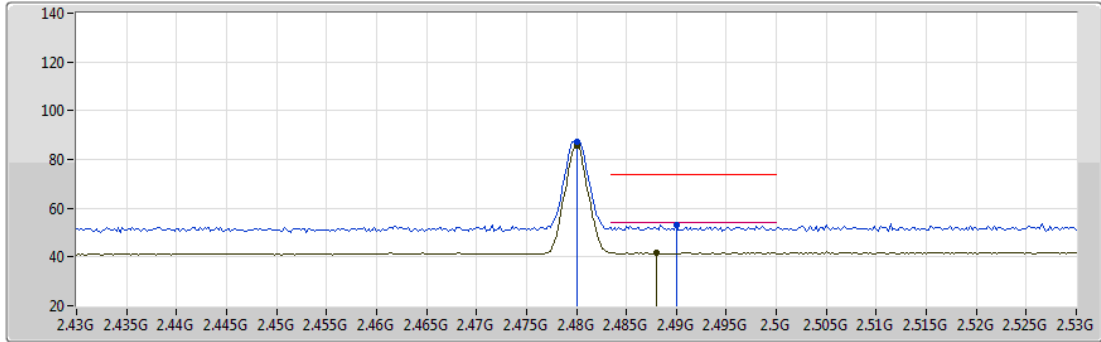

EUT Z\_1TX  
Setting Default  
01-A-B-4

Type	Freq (Hz)	Level (dBuV/m)	Limit (dBuV/m)	Margin (dB)	Raw (dBuV)	Dist (m)	Condition	Azimuth (°)	Height (m)	Comment	AF (dB)	CL (dB)	PA (dB)
PK	2.48G	87.11	Inf	-Inf	57.15	3	Vertical	60	1.00	-	27.68	2.28	-
AV	2.48G	85.58	Inf	-Inf	55.62	3	Vertical	60	1.00	-	27.68	2.28	-
PK	2.49G	53.30	74.00	-20.70	23.27	3	Vertical	60	1.00	-	27.74	2.29	-
AV	2.488G	41.76	54.00	-12.24	11.74	3	Vertical	60	1.00	-	27.73	2.29	-

**BT-LE(1Mbps)**

01/02/2021

**2480MHz\_TX**

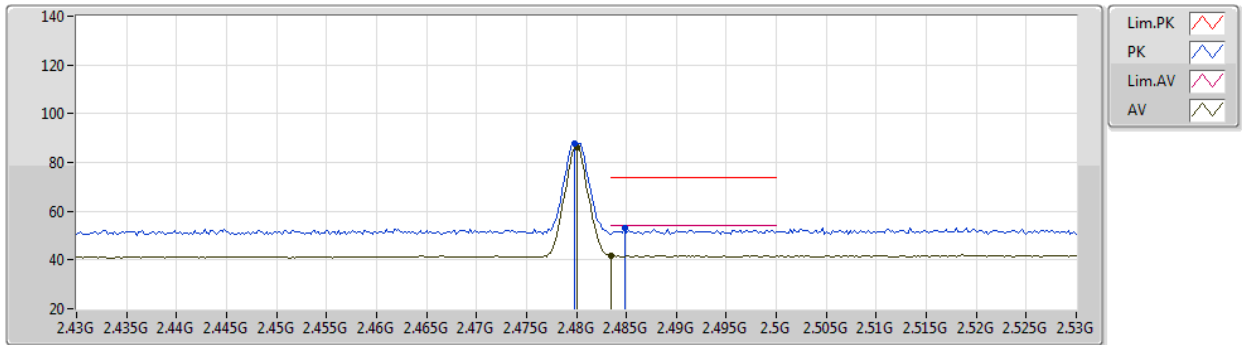

EUT Z\_1TX  
Setting Default  
01-A-B-4

Type	Freq (Hz)	Level (dBuV/m)	Limit (dBuV/m)	Margin (dB)	Raw (dBuV)	Dist (m)	Condition	Azimuth (°)	Height (m)	Comment	AF (dB)	CL (dB)	PA (dB)
PK	2.4798G	87.76	Inf	-Inf	57.80	3	Horizontal	33	1.03	-	27.68	2.28	-
AV	2.48G	86.10	Inf	-Inf	56.14	3	Horizontal	33	1.03	-	27.68	2.28	-
PK	2.4848G	52.89	74.00	-21.11	22.90	3	Horizontal	33	1.03	-	27.71	2.28	-
AV	2.4835G	41.92	54.00	-12.08	11.94	3	Horizontal	33	1.03	-	27.70	2.28	-

**BT-LE(1Mbps)**

01/02/2021

**2480MHz\_TX**

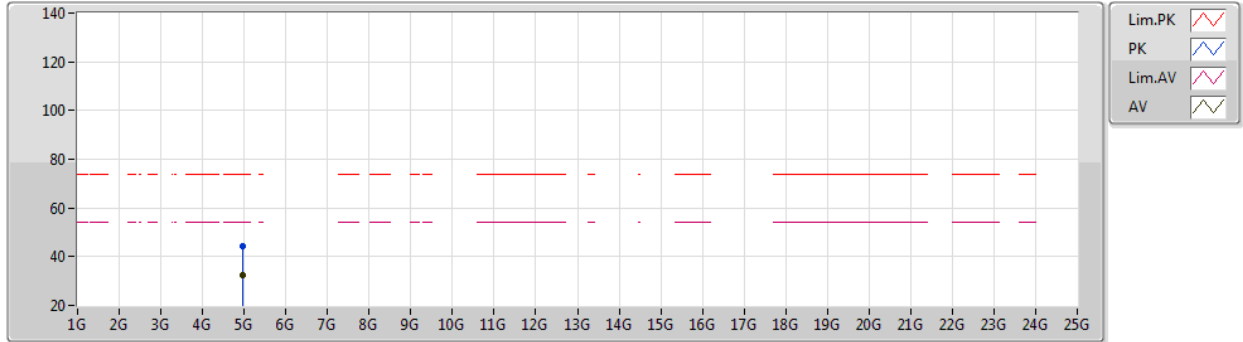

EUT Z\_1TX  
Setting Default  
01-A-B-4

Type	Freq (Hz)	Level (dBuV/m)	Limit (dBuV/m)	Margin (dB)	Raw (dBuV)	Dist (m)	Condition	Azimuth (°)	Height (m)	Comment	AF (dB)	CL (dB)	PA (dB)
PK	4.95924G	44.15	74.00	-29.85	40.78	3	Vertical	350	1.01	-	32.78	5.08	34.49
AV	4.96004G	32.46	54.00	-21.54	29.09	3	Vertical	350	1.01	-	32.78	5.08	34.49

**BT-LE(1Mbps)**

01/02/2021

**2480MHz\_TX**

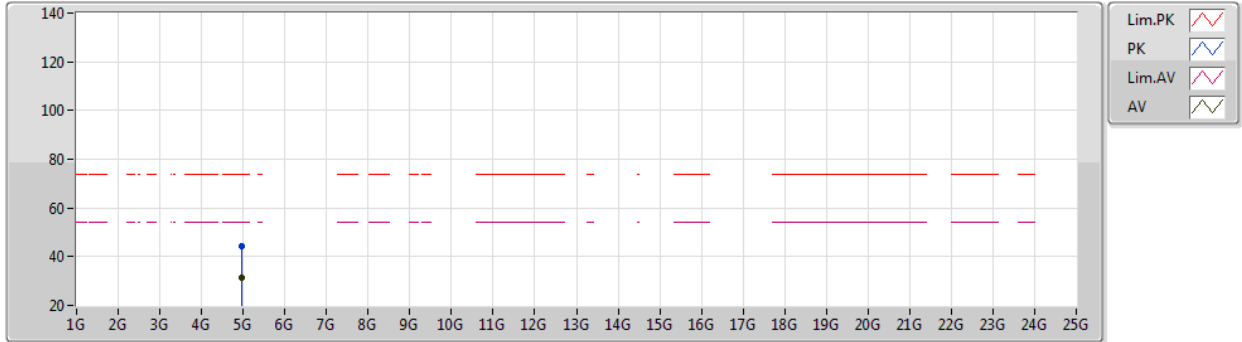

EUT Z\_1TX  
Setting Default  
01-A-B-4

Type	Freq (Hz)	Level (dBuV/m)	Limit (dBuV/m)	Margin (dB)	Raw (dBuV)	Dist (m)	Condition	Azimuth (°)	Height (m)	Comment	AF (dB)	CL (dB)	PA (dB)
PK	4.95763G	44.49	74.00	-29.51	41.12	3	Horizontal	10	2.04	-	32.78	5.08	34.49
AV	4.96201G	31.38	54.00	-22.62	28.01	3	Horizontal	10	2.04	-	32.78	5.08	34.49