

FCC Test Report

Report No.: RF160819C08-1

FCC ID: UDX-60057010

Test Model: MR74-HW

Received Date: Aug. 19, 2016

Test Date: Aug. 31 ~ Nov. 25, 2016

Issued Date: Dec. 05, 2016

Applicant: Cisco Systems, Inc.

Address: 170 West Tasman Drive, San Jose, CA 95134

Issued By: Bureau Veritas Consumer Products Services (H.K.) Ltd., Taoyuan Branch

Lab Address: No. 47-2, 14th Ling, Chia Pau Vil., Lin Kou Dist., New Taipei City, Taiwan (R.O.C.)

Test Location: No. 19, Hwa Ya 2nd Rd., Wen Hwa Vil., Kwei Shan Dist., Taoyuan City 33383, TAIWAN (R.O.C.)



This report is for your exclusive use. Any copying or replication of this report to or for any other person or entity, or use of our name or trademark, is permitted only with our prior written permission. This report sets forth our findings solely with respect to the test samples identified herein. The results set forth in this report are not indicative or representative of the quality or characteristics of the lot from which a test sample was taken or any similar or identical product unless specifically and expressly noted. Our report includes all of the tests requested by you and the results thereof based upon the information that you provided to us. You have 60 days from date of issuance of this report to notify us of any material error or omission caused by our negligence, provided, however, that such notice shall be in writing and shall specifically address the issue you wish to raise. A failure to raise such issue within the prescribed time shall constitute your unqualified acceptance of the completeness of this report, the tests conducted and the correctness of the report contents. Unless specific mention, the uncertainty of measurement has been explicitly taken into account to declare the compliance or non-compliance to the specification. The report must not be used by the client to claim product certification, approval, or endorsement by TAF or any government agencies.

Table of Contents

Release Control Record	4
1 Certificate of Conformity	5
2 Summary of Test Results	6
2.1 Measurement Uncertainty.....	6
2.2 Modification Record.....	6
3 General Information	7
3.1 General Description of EUT.....	7
3.2 Description of Test Modes.....	13
3.2.1 Test Mode Applicability and Tested Channel Detail.....	14
3.3 Duty Cycle of Test Signal.....	17
3.4 Description of Support Units.....	19
3.4.1 Configuration of System under Test.....	19
3.5 General Description of Applied Standards.....	19
4 Test Types and Results	20
4.1 Radiated Emission and Bandedge Measurement.....	20
4.1.1 Limits of Radiated Emission and Bandedge Measurement.....	20
4.1.2 Test Instruments.....	21
4.1.3 Test Procedures.....	22
4.1.4 Deviation from Test Standard.....	22
4.1.5 Test Setup.....	23
4.1.6 EUT Operating Conditions.....	24
4.1.7 Test Results.....	25
4.2 Conducted Emission Measurement.....	139
4.2.1 Limits of Conducted Emission Measurement.....	139
4.2.2 Test Instruments.....	139
4.2.3 Test Procedures.....	140
4.2.4 Deviation from Test Standard.....	140
4.2.5 Test Setup.....	140
4.2.6 EUT Operating Conditions.....	140
4.2.7 Test Results.....	141
4.3 Transmit Power Measurement.....	153
4.3.1 Limits of Transmit Power Measurement.....	153
4.3.2 Test Setup.....	153
4.3.3 Test Instruments.....	154
4.3.4 Test Procedure.....	154
4.3.5 Deviation from Test Standard.....	154
4.3.6 EUT Operating Conditions.....	154
4.3.7 Test Result.....	155
4.4 Occupied Bandwidth Measurement.....	189
4.4.1 Test Setup.....	189
4.4.2 Test Instruments.....	189
4.4.3 Test Procedure.....	189
4.4.4 Test Result.....	190
4.5 Peak Power Spectral Density Measurement.....	202
4.5.1 Limits of Peak Power Spectral Density Measurement.....	202
4.5.2 Test Setup.....	202
4.5.3 Test Instruments.....	202
4.5.4 Test Procedures.....	203
4.5.5 Deviation from Test Standard.....	203
4.5.6 EUT Operating Conditions.....	203
4.5.7 Test Results.....	204
4.6 Frequency Stability.....	233
4.6.1 Limits of Frequency Stability Measurement.....	233

4.6.2	Test Setup.....	233
4.6.3	Test Procedure	233
4.6.4	Deviation from Test Standard	233
4.6.5	EUT Operating Condition	233
4.6.6	Test Results	234
4.7	6dB Bandwidth Measurement.....	240
4.7.1	Limits of 6dB Bandwidth Measurement.....	240
4.7.2	Test Setup.....	240
4.7.3	Test Instruments	240
4.7.4	Test Procedure	240
4.7.5	Deviation from Test Standard	240
4.7.6	EUT Operating Condition	240
4.7.7	Test Results	241
5	Pictures of Test Arrangements.....	253
	Annex A- Radiated Out of Band Emission (OOBE) Measurement (For U-NII-3 band).....	254
	Appendix – Information on the Testing Laboratories	272

Release Control Record

Issue No.	Description	Date Issued
RF160819C08-1	Original release	Dec. 05, 2016

1 Certificate of Conformity

Product: AP Outdoor
Brand: Cisco
Test Model: MR74-HW
Sample Status: Engineering sample
Applicant: Cisco Systems, Inc.
Test Date: Aug. 31 ~ Nov. 25, 2016
Standards: 47 CFR FCC Part 15, Subpart E (Section 15.407)
ANSI C63.10:2013

The above equipment has been tested by **Bureau Veritas Consumer Products Services (H.K.) Ltd., Taoyuan Branch**, and found compliance with the requirement of the above standards. The test record, data evaluation & Equipment Under Test (EUT) configurations represented herein are true and accurate accounts of the measurements of the sample's EMC characteristics under the conditions specified in this report.

Prepared by : *Suntee Liu* , **Date:** Dec. 05, 2016
Suntee Liu / Specialist

Approved by : *Ken Liu* , **Date:** Dec. 05, 2016
Ken Liu / Senior Manager

2 Summary of Test Results

47 CFR FCC Part 15, Subpart E (Section 15.407)			
FCC Clause	Test Item	Result	Remarks
15.407(b)(6)	AC Power Conducted Emissions	Pass	Meet the requirement of limit. Minimum passing margin is -8.11dB at 13.65234MHz.
15.407(b)(1/2/3/4(i/ii)/6)	Radiated Emissions & Band Edge Measurement	Pass	Meet the requirement of limit. Minimum passing margin is -1.1dB at 11650.00MHz.
15.407(a)(1/2/3)	Max Average Transmit Power	Pass	Meet the requirement of limit.
---	Occupied Bandwidth Measurement	-	Reference only.
15.407(a)(1/2/3)	Peak Power Spectral Density	Pass	Meet the requirement of limit.
15.407(e)	6dB bandwidth	Pass	Meet the requirement of limit. (U-NII-3 Band only)
15.407(g)	Frequency Stability	Pass	Meet the requirement of limit.
15.203	Antenna Requirement	Pass	For Omni-direction, Sector, Patch antennas: Antenna connector is N-Type. (The device is professionally installed) For PIFA antenna: No antenna connector is used.

*For U-NII-3 band compliance with rule part 15.407(b)(4)(i), the OOB test plots were recorded in Annex A.

2.1 Measurement Uncertainty

Where relevant, the following measurement uncertainty levels have been estimated for tests performed on the EUT as specified in CISPR 16-4-2:

Measurement	Frequency	Expanded Uncertainty (k=2) (\pm)
Conducted Emissions at mains ports	150kHz ~ 30MHz	2.44 dB
Radiated Emissions up to 1 GHz	30MHz ~ 200MHz	3.86 dB
	200MHz ~ 1000MHz	3.87 dB
Radiated Emissions above 1 GHz	1GHz ~ 18GHz	2.29 dB
	18GHz ~ 40GHz	2.29 dB

2.2 Modification Record

There were no modifications required for compliance.

3 General Information

3.1 General Description of EUT

Product	AP Outdoor
Brand	Cisco
Test Model	MR74-HW
Sample Status	Engineering sample
Power Supply Rating	55Vdc (POE)
Modulation Type	256QAM, 64QAM, 16QAM, QPSK, BPSK
Modulation Technology	OFDM
Transfer Rate	802.11a: 54.0/ 48.0/ 36.0/ 24.0/ 18.0/ 12.0/ 9.0/ 6.0Mbps 802.11n: up to 300Mbps 802.11ac: up to 867Mbps
Operating Frequency	5180 ~ 5240MHz, 5745 ~ 5825MHz
Number of Channel	5180 ~ 5240MHz: 4 for 802.11a, 802.11n (HT20), 802.11ac (VHT20) 2 for 802.11n (HT40), 802.11ac (VHT40) 1 for 802.11ac (VHT80) 5745 ~ 5825MHz: 5 for 802.11a, 802.11n (HT20), 802.11ac (VHT20) 2 for 802.11n (HT40), 802.11ac (VHT40) 1 for 802.11ac (VHT80)

Output Power	<p>Radio 2, Ant. No. 20: CDD Mode 5180 ~ 5240MHz: 154.214mW 5745 ~ 5825MHz: 323.04mW Beamforming Mode 5180 ~ 5240MHz: 77.112mW 5745 ~ 5825MHz: 161.531mW</p> <p>Radio 2, Ant. No. 21: CDD Mode 5180 ~ 5240MHz: 9.533mW 5745 ~ 5825MHz: 184.460mW Beamforming Mode 5180 ~ 5240MHz: 4.767mW 5745 ~ 5825MHz: 92.236mW</p> <p>Radio 2, Ant. No. 25: CDD Mode 5180 ~ 5240MHz: 82.482mW 5745 ~ 5825MHz: 342.921mW Beamforming Mode 5180 ~ 5240MHz: 41.244mW 5745 ~ 5825MHz: 168.551mW</p> <p>Radio 2, Ant. No. 27: CDD Mode 5180 ~ 5240MHz: 13.313mW 5745 ~ 5825MHz: 281.849mW Beamforming Mode 5180 ~ 5240MHz: 6.657mW 5745 ~ 5825MHz: 140.935mW</p> <p>Radio 2, Ant. No. AIR-ANT2513P4M-N: CDD Mode 5180 ~ 5240MHz: 103.896mW 5745 ~ 5825MHz: 184.460mW Beamforming Mode 5180 ~ 5240MHz: 51.952mW 5745 ~ 5825MHz: 92.236mW</p> <p>Radio 3: 5180 ~ 5240MHz: 37.757mW 5745 ~ 5825MHz: 71.614mW</p>
Antenna Type	Refer to Note
Antenna Connector	Refer to Note
Accessory Device	Antenna, 1m non-shielded ground cable w/o core
Data Cable Supplied	NA

Note:

1. The EUT incorporates a MIMO function. Physically, the EUT provides 2 completed transmitters and 2 receivers.

2.4GHz Band			
Modulation Mode	TX Function	Beamforming	Remark
802.11b	2TX	Not Support	Radio 1
802.11g	2TX	Not Support	
802.11n (HT20)	2TX	Support	
802.11n (HT40)	2TX	Support	
802.11b	1TX	Not Support	Radio 3
802.11g	1TX	Not Support	
802.11n (HT20)	1TX	Not Support	
802.11n (HT40)	1TX	Not Support	
5GHz Band			
Modulation Mode	TX Function	Beamforming	Remark
802.11a	2TX	Not Support	Radio 2
802.11n (HT20)	2TX	Support	
802.11n (HT40)	2TX	Support	
802.11ac (VHT20)	2TX	Support	
802.11ac (VHT40)	2TX	Support	
802.11ac (VHT80)	2TX	Support	
802.11a	1TX	Not Support	Radio 3
802.11n (HT20)	1TX	Not Support	
802.11n (HT40)	1TX	Not Support	
802.11ac (VHT20)	1TX	Not Support	
802.11ac (VHT40)	1TX	Not Support	
802.11ac (VHT80)	1TX	Not Support	

* The modulation and bandwidth are similar for 802.11n mode for HT20/HT40 and 802.11ac mode for VHT20/VHT40, therefore investigated worst case to representative mode in test report. (Final test mode refer section 3.2.1)

* For 802.11n and 802.11ac, CDD mode and Beamforming mode are presented in power output test item. For other test items, CDD mode is the worst case for final tests after pretesting.

2. The EUT consumes power from the following POE. (support unit only)

Brand	CISCO
Model	MA-INJ-4
Input Power	100-240Vac, 50/60Hz, 0.67A
Output Power	55Vdc, 0.6A
Power Line	1.4m non-shielded AC cable without core

3. The EUT uses following antennas.

Ant. No.	Ant. Type	Connector	Cable	Antenna Gain (dBi)		Remark							
				Frequency (GHz)									
				2.4	5								
20	Omni-directional	N-Type	-	4	7	Radio 1 (WLAN 2.4G), Radio 2 (WLAN 5G)							
21	Sector	N-Type	0.35m coaxial X2	-	13								
23			0.35m coaxial X2	11	-								
25	Sector	N-Type	0.35m coaxial X2	8.1	7.1								
27	Sector	N-Plug	0.35m coaxial X2	9.8	11.3								
AIR-ANT2513 P4M-N	Patch	N-Female Bulkhead	3m coaxial X2	13	13								
Ant. No.	Ant. Type	Connector	Cable	Antenna Gain (dBi)								Remark	
				Frequency (GHz)									
				2.4	2.45	2.5	4.9	5.15	5.35	5.475	5.725		5.875
-	PIFA	NA	-	3.0	3.7	3.9	6.3	5.2	4.9	4.6	4.8	4.1	Radio 3 (WLAN 2.4G, 5G)
-	PIFA	NA	-	5.3	5.6	4.6	-	-	-	-	-	-	Radio 4 (BT LE)

* The 2.4GHz max. gain of PIFA antenna was chosen for final test.

* The 5GHz max. gain of PIFA antenna was chosen for final test.

4. The EUT will be installed at outdoor area, the highest antenna gains from the horizon above 30 degrees are as below, for more detail information please refer to antenna specification and user manual.

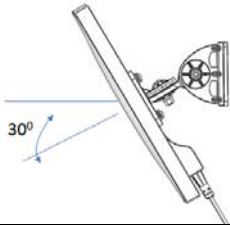
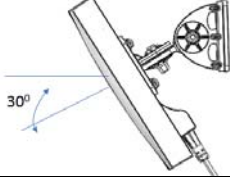
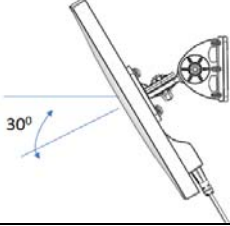
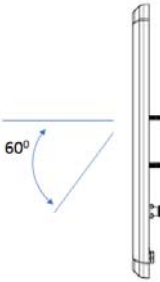
Radio	Ant. No.	Antenna Gain (dBi)	Antenna Install Degree
2	20	-1	
	Due to device Will restricted installation position as above photo, thus consider to above 30 degrees highest antenna gain are chosen from XZ and YZ Plane (antenna specification of 60~-60 degrees and 120~-120 degrees).		
	21	11.2	
	Due to device Will restricted installation position as above photo, thus consider to above 30 degrees highest antenna gain are chosen from XZ and YZ Plane (antenna specification of 30~180 degrees).		
	25	1.8	
	Due to device Will restricted installation position as above photo, thus consider to above 30 degrees highest antenna gain are chosen from XZ and YZ Plane (antenna specification of 60~180 degrees and -150~-180 degrees).		
	27	9.7	
	Due to device Will restricted installation position as above photo, thus consider to above 30 degrees highest antenna gain are chosen from XZ and YZ Plane (antenna specification of 30~180 degrees).		
	AIR-ANT2513P4M-N	0.77	
Due to device Will restricted installation position as above photo, thus consider to above 30 degrees highest antenna gain are chosen from Azimuth and Elevation Plane (antenna specification of 0~30 degrees and 210~360 degrees).			

Radio	Ant. No.	Antenna Gain (dBi)	Antenna Install Degree
3	-	5.20	
Due to device Will restricted installation position as above photo, thus consider to above 30 degrees highest antenna gain are chosen from Max Gain.			

5. 2.4GHz, 5GHz and BT LE technology can transmit at same time.
6. Spurious emission of the simultaneous operation (2.4GHz, 5GHz and BT LE) has been evaluated and no non-compliance was found.

3.2 Description of Test Modes

For 5180 ~ 5240MHz

4 channels are provided for 802.11a, 802.11n (HT20), 802.11ac (VHT20):

Channel	Frequency	Channel	Frequency
36	5180 MHz	44	5220 MHz
40	5200 MHz	48	5240 MHz

2 channels are provided for 802.11n (HT40), 802.11ac (VHT40):

Channel	Frequency	Channel	Frequency
38	5190 MHz	46	5230 MHz

1 channel is provided for 802.11ac (VHT80):

Channel	Frequency
42	5210MHz

For 5745 ~ 5825MHz

5 channels are provided for 802.11a, 802.11n (HT20), 802.11ac (VHT20):

Channel	Frequency	Channel	Frequency
149	5745MHz	161	5805MHz
153	5765MHz	165	5825MHz
157	5785MHz		

2 channels are provided for 802.11n (HT40), 802.11ac (VHT40):

Channel	Frequency	Channel	Frequency
151	5755MHz	159	5795MHz

1 channel is provided for 802.11ac (VHT80):

Channel	Frequency
155	5775MHz

3.2.1 Test Mode Applicability and Tested Channel Detail

EUT Configure Mode	Applicable to				Description
	RE \geq 1G	RE<1G	PLC	APCM	
A	√	√	√	√	EUT with Omni-directional ant. (Ant. 20)
B	√	√	√	√	EUT with sector ant. (Ant. 21)
C	√	√	√	√	EUT with sector ant. (Ant. 25)
D	√	√	√	√	EUT with sector ant. (Ant. 27)
E	√	√	√	√	EUT with Patch ant. (AIR-ANT2513P4M-N)
F	√	√	√	√	EUT with PIFA ant.

Where RE \geq 1G: Radiated Emission above 1GHz & Bandedge Measurement RE<1G: Radiated Emission below 1GHz
 PLC: Power Line Conducted Emission APCM: Antenna Port Conducted Measurement

Note: The EUT had been pre-tested on the positioned of each 3 axis. The worst case was found when positioned on Z-plane.

Radiated Emission Test (Above 1GHz):

- Pre-Scan has been conducted to determine the worst-case mode from all possible combinations between available modulations, data rates and antenna ports (if EUT with antenna diversity architecture).
- Following channel(s) was (were) selected for the final test as listed below.

EUT Configure Mode	Mode	Freq. Band (MHz)	Available Channel	Tested Channel	Modulation Technology	Modulation Type	Data Rate (Mbps)	Remark	
A, B, C, D, E	802.11a	5180-5240	36 to 48	36, 40, 48	OFDM	BPSK	6.0	Radio 2 (2TX)	
F			36 to 48	36, 40, 48	OFDM	BPSK	6.0	Radio 3 (1TX)	
A, B, C, D, E	802.11n (HT20)		36 to 48	36, 40, 48	OFDM	BPSK	7.2	Radio 2 (2TX)	
F			36 to 48	36, 40, 48	OFDM	BPSK	6.5	Radio 3 (1TX)	
A, B, C, D, E	802.11n (HT40)		38 to 46	38, 46	OFDM	BPSK	15.0	Radio 2 (2TX)	
F			38 to 46	38, 46	OFDM	BPSK	13.5	Radio 3 (1TX)	
A, B, C, D, E	802.11ac (VHT80)		42	42	OFDM	BPSK	65.0	Radio 2 (2TX)	
F			42	42	OFDM	BPSK	29.3	Radio 3 (1TX)	
A, B, C, D, E	802.11a		5745-5825	149 to 165	149, 157, 165	OFDM	BPSK	6.0	Radio 2 (2TX)
F				149 to 165	149, 157, 165	OFDM	BPSK	6.0	Radio 3 (1TX)
A, B, C, D, E	802.11n (HT20)			149 to 165	149, 157, 165	OFDM	BPSK	7.2	Radio 2 (2TX)
F				149 to 165	149, 157, 165	OFDM	BPSK	6.5	Radio 3 (1TX)
A, B, C, D, E	802.11n (HT40)	151 to 159		151, 159	OFDM	BPSK	15.0	Radio 2 (2TX)	
F		151 to 159		151, 159	OFDM	BPSK	13.5	Radio 3 (1TX)	
A, B, C, D, E	802.11ac (VHT80)	155		155	OFDM	BPSK	65.0	Radio 2 (2TX)	
F		155		155	OFDM	BPSK	29.3	Radio 3 (1TX)	

Radiated Emission Test (Below 1GHz):

- Pre-Scan has been conducted to determine the worst-case mode from all possible combinations between available modulations, data rates and antenna ports (if EUT with antenna diversity architecture).
- Following channel(s) was (were) selected for the final test as listed below.

EUT Configure Mode	Mode	Freq. Band (MHz)	Available Channel	Tested Channel	Modulation Technology	Modulation Type	Data Rate (Mbps)	Remark
A, B, C, D, E	802.11a	5180-5240	36 to 48	149	OFDM	BPSK	6.0	Radio 2 (2TX)
		5745-5825	149 to 165		OFDM	BPSK	6.0	Radio 2 (2TX)
F	802.11a	5180-5240	36 to 48	149	OFDM	BPSK	6.0	Radio 3 (1TX)
		5745-5825	149 to 165		OFDM	BPSK	6.0	Radio 3 (1TX)

Power Line Conducted Emission Test:

- Pre-Scan has been conducted to determine the worst-case mode from all possible combinations between available modulations, data rates and antenna ports (if EUT with antenna diversity architecture).
- Following channel(s) was (were) selected for the final test as listed below.

EUT Configure Mode	Mode	Freq. Band (MHz)	Available Channel	Tested Channel	Modulation Technology	Modulation Type	Data Rate (Mbps)	Remark
A, B, C, D, E	802.11a	5180-5240	36 to 48	149	OFDM	BPSK	6.0	Radio 2 (2TX)
		5745-5825	149 to 165		OFDM	BPSK	6.0	Radio 2 (2TX)
F	802.11a	5180-5240	36 to 48	149	OFDM	BPSK	6.0	Radio 3 (1TX)
		5745-5825	149 to 165		OFDM	BPSK	6.0	Radio 3 (1TX)

Antenna Port Conducted Measurement:

- This item includes all test value of each mode, but only includes spectrum plot of worst value of each mode.
- Pre-Scan has been conducted to determine the worst-case mode from all possible combinations between available modulations, data rates and antenna ports (if EUT with antenna diversity architecture).
- Following channel(s) was (were) selected for the final test as listed below.

EUT Configure Mode	Mode	Freq. Band (MHz)	Available Channel	Tested Channel	Modulation Technology	Modulation Type	Data Rate (Mbps)	Remark	
A, B, C, D, E	802.11a	5180-5240	36 to 48	36, 40, 48	OFDM	BPSK	6.0	Radio 2 (2TX)	
F			36 to 48	36, 40, 48	OFDM	BPSK	6.0	Radio 3 (1TX)	
A, B, C, D, E	802.11n (HT20)		36 to 48	36, 40, 48	OFDM	BPSK	7.2	Radio 2 (2TX)	
F			36 to 48	36, 40, 48	OFDM	BPSK	6.5	Radio 3 (1TX)	
A, B, C, D, E	802.11n (HT40)		38 to 46	38, 46	OFDM	BPSK	15.0	Radio 2 (2TX)	
F			38 to 46	38, 46	OFDM	BPSK	13.5	Radio 3 (1TX)	
A, B, C, D, E	802.11ac (VHT80)		42	42	OFDM	BPSK	65.0	Radio 2 (2TX)	
F			42	42	OFDM	BPSK	29.3	Radio 3 (1TX)	
A, B, C, D, E	802.11a		5745-5825	149 to 165	149, 157, 165	OFDM	BPSK	6.0	Radio 2 (2TX)
F				149 to 165	149, 157, 165	OFDM	BPSK	6.0	Radio 3 (1TX)
A, B, C, D, E	802.11n (HT20)			149 to 165	149, 157, 165	OFDM	BPSK	7.2	Radio 2 (2TX)
F				149 to 165	149, 157, 165	OFDM	BPSK	6.5	Radio 3 (1TX)
A, B, C, D, E	802.11n (HT40)	151 to 159		151, 159	OFDM	BPSK	15.0	Radio 2 (2TX)	
F		151 to 159		151, 159	OFDM	BPSK	13.5	Radio 3 (1TX)	
A, B, C, D, E	802.11ac (VHT80)	155		155	OFDM	BPSK	65.0	Radio 2 (2TX)	
F		155		155	OFDM	BPSK	29.3	Radio 3 (1TX)	

Test Condition:

Applicable to	Environmental Conditions	Input Power (System)	Tested by
RE\geq1G	19 deg. C, 70% RH 18 deg. C, 70% RH	120Vac, 60Hz	Jones Chang James Yang Nick Hsu
RE<1G	16 deg. C, 70% RH	120Vac, 60Hz	Nick Hsu
PLC	20 deg. C, 70% RH	120Vac, 60Hz	Jones Chang
APCM	25 deg. C, 60% RH	120Vac, 60Hz	Leo Tsai Frank Liu Jones Chang

3.3 Duty Cycle of Test Signal

Duty cycle of test signal is $\geq 98\%$, duty factor is not required.
 Duty cycle of test signal is $< 98\%$, duty factor shall be considered.

Radio 2

802.11a: Duty cycle = $2.055/2.155 = 0.954$, Duty factor = $10 * \log(1/0.954) = 0.21$

802.11n (HT20): Duty cycle = $4.987/5.077 = 0.982$

802.11n (HT40): Duty cycle = $2.425/2.533 = 0.957$, Duty factor = $10 * \log(1/0.957) = 0.19$

802.11ac (VHT80): Duty cycle = $1.14/1.23 = 0.927$, Duty factor = $10 * \log(1/0.927) = 0.33$

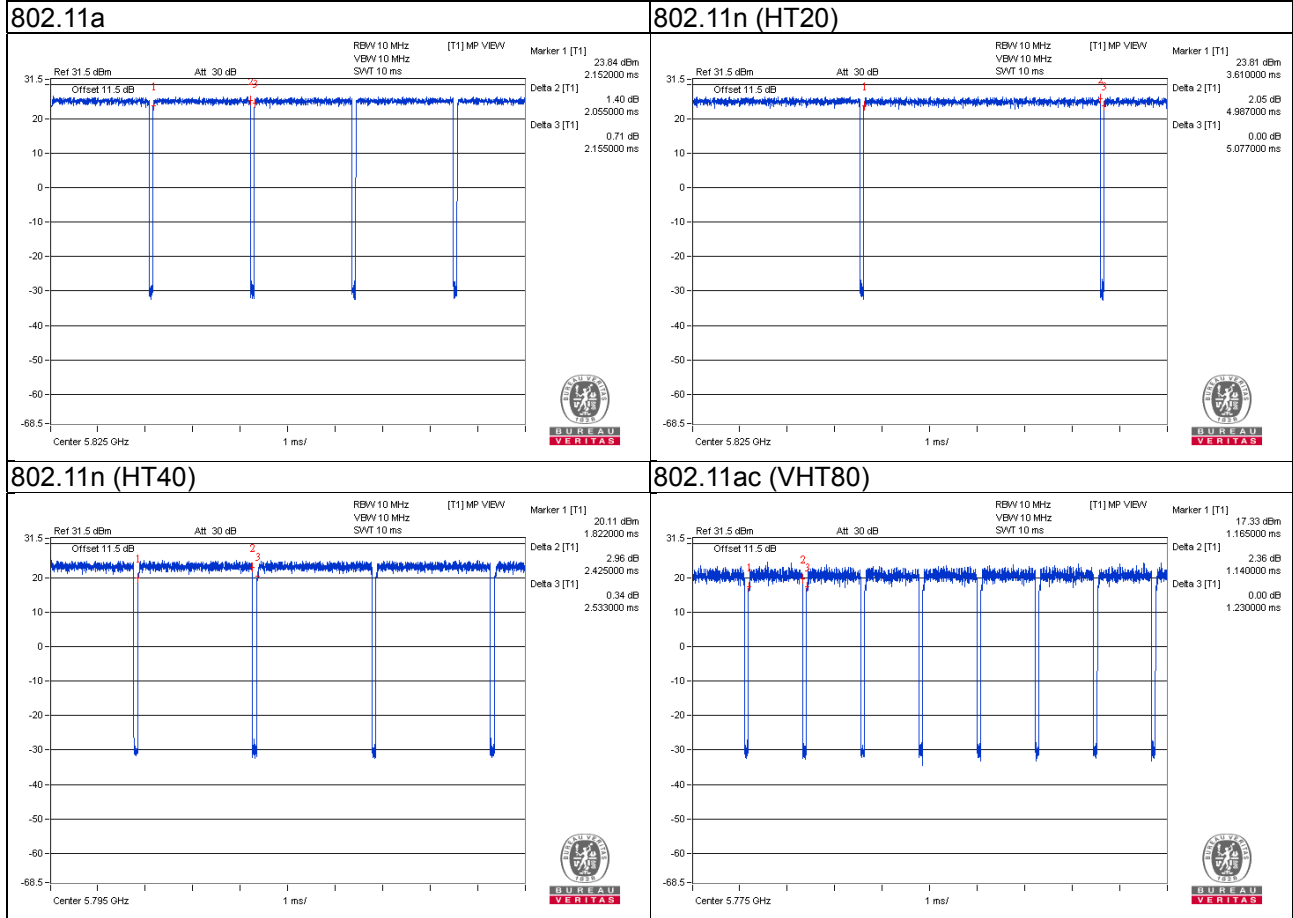

Radio 3

802.11a: Duty cycle = $2.059/2.134 = 0.965$, Duty factor = $10 * \log(1/0.965) = 0.16$

802.11n (HT20): Duty cycle = $1.92/2 = 0.960$, Duty factor = $10 * \log(1/0.960) = 0.18$

802.11n (HT40): Duty cycle = $0.947/1.034 = 0.916$, Duty factor = $10 * \log(1/0.916) = 0.38$

802.11ac (VHT80): Duty cycle = $0.463/0.531 = 0.872$, Duty factor = $10 * \log(1/0.872) = 0.60$

802.11a

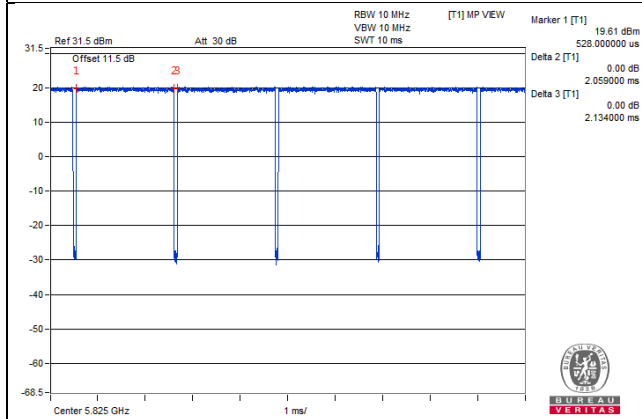

802.11n (HT20)

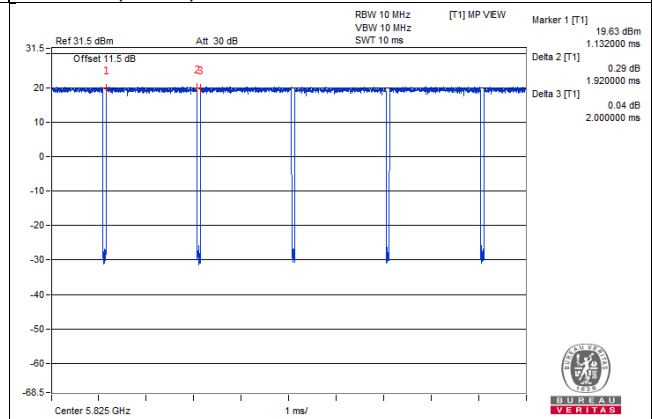

802.11n (HT40)

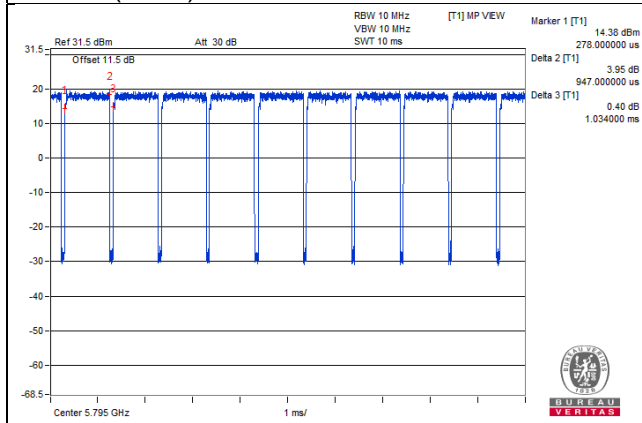

802.11ac (VHT80)

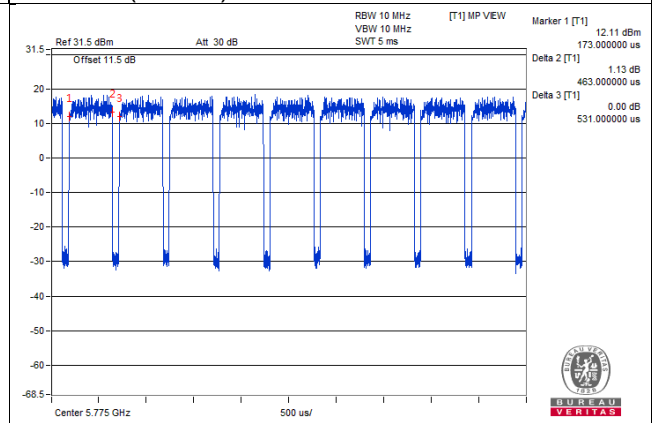

3.4 Description of Support Units

The EUT has been tested as an independent unit together with other necessary accessories or support units. The following support units or accessories were used to form a representative test configuration during the tests.

ID	Product	Brand	Model No.	Serial No.	FCC ID	Remarks
A.	POE	CISCO	MA-INJ-4	N/A	N/A	Provided by manufacturer
B.	Notebook	DELL	Latitude E6420	HPFC5Q1	FCC DoC Approved	-

Note:

1. All power cords of the above support units are non-shielded (1.8m).
2. Item B acted as a communication partner to transfer data.

ID	Descriptions	Qty.	Length (m)	Shielding (Yes/No)	Cores (Qty.)	Remarks
1.	RJ45, Cat5e	1	3	N	0	-
2.	RJ45, Cat5e	1	1.8	N	0	-

3.4.1 Configuration of System under Test

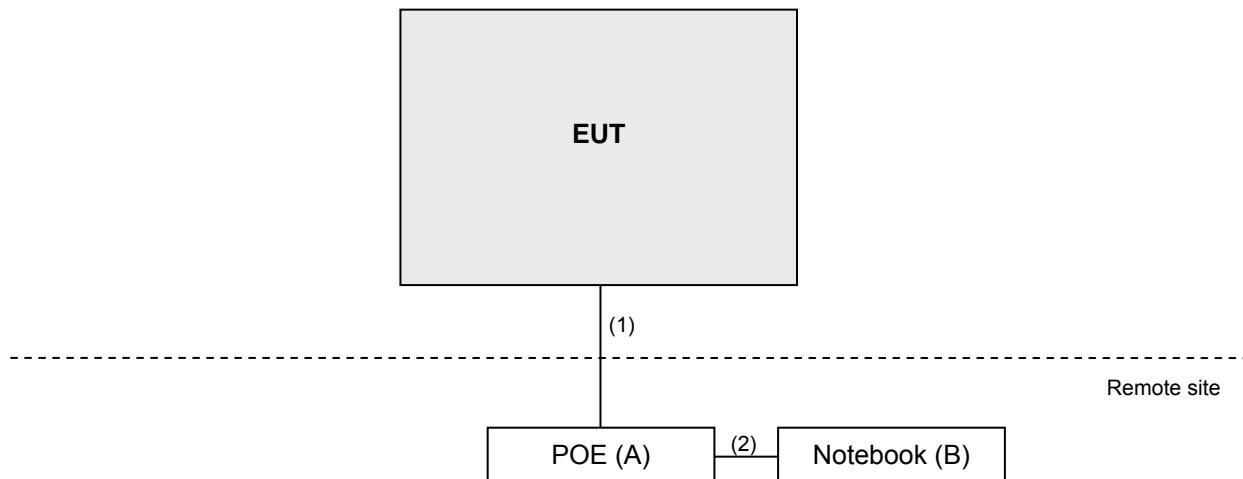

3.5 General Description of Applied Standards

The EUT is a RF Product. According to the specifications of the manufacturer, it must comply with the requirements of the following standards:

FCC Part 15, Subpart E (15.407)

KDB 789033 D02 General UNII Test Procedure New Rules v01r03

KDB 662911 D01 Multiple Transmitter Output v02r01

ANSI C63.10-2013

All test items have been performed and recorded as per the above standards.

4 Test Types and Results

4.1 Radiated Emission and Bandedge Measurement

4.1.1 Limits of Radiated Emission and Bandedge Measurement

Radiated emissions which fall in the restricted bands must comply with the radiated emission limits specified as below table.

Frequencies (MHz)	Field Strength (microvolts/meter)	Measurement Distance (meters)
0.009 ~ 0.490	2400/F(kHz)	300
0.490 ~ 1.705	24000/F(kHz)	30
1.705 ~ 30.0	30	30
30 ~ 88	100	3
88 ~ 216	150	3
216 ~ 960	200	3
Above 960	500	3

NOTE:

1. The lower limit shall apply at the transition frequencies.
2. Emission level (dBuV/m) = 20 log Emission level (uV/m).
3. For frequencies above 1000MHz, the field strength limits are based on average detector, however, the peak field strength of any emission shall not exceed the maximum permitted average limits, specified above by more than 20dB under any condition of modulation.

Limits of unwanted emission out of the restricted bands

Applicable To		Limit	
789033 D02 General UNII Test Procedure New Rules v01r03		Field Strength at 3m	
		PK:74 (dBµV/m)	AV:54 (dBµV/m)
Frequency Band	Applicable To	EIRP Limit	Equivalent Field Strength at 3m
5150~5250 MHz	15.407(b)(1)	PK:-27 (dBm/MHz)	PK:68.2(dBµV/m)
5250~5350 MHz	15.407(b)(2)		
5470~5725 MHz	15.407(b)(3)		
5725~5850 MHz	<input checked="" type="checkbox"/> 15.407(b)(4)(i)	PK:-27 (dBm/MHz) ^{*1} PK:10 (dBm/MHz) ^{*2} PK:15.6 (dBm/MHz) ^{*3} PK:27 (dBm/MHz) ^{*4}	PK: 68.2(dBµV/m) ^{*1} PK:105.2 (dBµV/m) ^{*2} PK: 110.8(dBµV/m) ^{*3} PK:122.2 (dBµV/m) ^{*4}
	<input type="checkbox"/> 15.407(b)(4)(ii)	Emission limits in section 15.247(d)	
^{*1} beyond 75 MHz or more above of the band edge.		^{*2} below the band edge increasing linearly to 10 dBm/MHz at 25 MHz above.	
^{*3} below the band edge increasing linearly to a level of 15.6 dBm/MHz at 5 MHz above.		^{*4} from 5 MHz above or below the band edge increasing linearly to a level of 27 dBm/MHz at the band edge.	

Note: The following formula is used to convert the equipment isotropic radiated power (eirp) to field strength:

$$E = \frac{1000000\sqrt{30P}}{3} \mu\text{V/m, where P is the eirp (Watts).}$$

4.1.2 Test Instruments

Description & Manufacturer	Model No.	Serial No.	Cal. Date	Cal. Due
Test Receiver ROHDE & SCHWARZ	ESIB7	100187	Apr. 18, 2016	Apr. 17, 2017
Spectrum Analyzer ROHDE & SCHWARZ	FSP40	100041	Sep. 02, 2015	Sep. 01, 2016
			Sep. 02, 2016	Sep. 01, 2017
BILOG Antenna SCHWARZBECK	VULB9168	9168-171	Jan. 07, 2016	Jan. 06, 2017
HORN Antenna SCHWARZBECK	9120D	209	Jan. 20, 2016	Jan. 19, 2017
HORN Antenna SCHWARZBECK	BBHA 9170	BBHA9170241	Jan. 18, 2016	Jan. 17, 2017
Loop Antenna	EM-6879	269	Aug. 11, 2016	Aug. 10, 2017
Preamplifier Agilent	8447D	2944A10738	Aug. 22, 2016	Aug. 21, 2017
Preamplifier Agilent	8449B	3008A01964	Aug. 22, 2016	Aug. 21, 2017
RF signal cable HUBER+SUHNER	SUCOFLEX 104	Cable-CH3-03 (214378)	Aug. 22, 2016	Aug. 21, 2017
RF signal cable HUBER+SUHNER	SUCOFLEX 106	Cable-CH3-03 (309224+12738)	Aug. 22, 2016	Aug. 21, 2017
Software BV ADT	ADT_Radiated_ V7.6.15.9.4	NA	NA	NA
Antenna Tower inn-co GmbH	MA 4000	013303	NA	NA
Antenna Tower Controller BV ADT	AT100	AT93021702	NA	NA
Turn Table BV ADT	TT100	TT93021702	NA	NA
Turn Table Controller BV ADT	SC100	SC93021702	NA	NA
High Speed Peak Power Meter	ML2495A	0824011	Jul. 09, 2016	Jul. 08, 2017
Power Sensor	MA2411B	0738171	Aug. 11, 2016	Aug. 10, 2017
26GHz ~ 40GHz Amplifier	EM26400	815221	Oct. 18, 2015	Oct. 17, 2016
			Oct. 17, 2016	Oct. 16, 2017

- Note:
1. The calibration interval of the above test instruments is 12 months and the calibrations are traceable to NML/ROC and NIST/USA.
 2. The test was performed in HwaYa Chamber 3.
 3. The horn antenna and preamplifier (model: 8449B) are used only for the measurement of emission frequency above 1GHz if tested.
 4. The FCC Site Registration No. is 988962.
 5. The IC Site Registration No. is IC 7450F-3.

4.1.3 Test Procedures

For Radiated emission below 30MHz

- a. The EUT was placed on the top of a rotating table 0.8 meters above the ground at a 3 meter chamber room. The table was rotated 360 degrees to determine the position of the highest radiation.
- b. The EUT was set 3 meters away from the interference-receiving antenna, which was mounted on the top of a variable-height antenna tower.
- c. Both X and Y axes of the antenna are set to make the measurement.
- d. For each suspected emission, the EUT was arranged to its worst case and the rotatable table was turned from 0 degrees to 360 degrees to find the maximum reading.
- e. The test-receiver system was set to Quasi-Peak Detect Function and Specified Bandwidth with Maximum Hold Mode.

Note:

1. The resolution bandwidth and video bandwidth of test receiver/spectrum analyzer is 9kHz at frequency below 30MHz.

For Radiated emission above 30MHz

- a. The EUT was placed on the top of a rotating table 0.8 meters (for 30MHz ~ 1GHz) / 1.5 meters (for above 1GHz) above the ground at 3 meter chamber room for test. The table was rotated 360 degrees to determine the position of the highest radiation.
- b. The EUT was set 3 meters away from the interference-receiving antenna, which was mounted on the top of a variable-height antenna tower.
- c. The height of antenna is varied from one meter to four meters above the ground to determine the maximum value of the field strength. Both horizontal and vertical polarizations of the antenna are set to make the measurement.
- d. For each suspected emission, the EUT was arranged to its worst case and then the antenna was tuned to heights from 1 meter to 4 meters and the rotatable table was turned from 0 degrees to 360 degrees to find the maximum reading.
- e. The test-receiver system was set to quasi-peak detect function and specified bandwidth with maximum hold mode when the test frequency is below 1 GHz.
- f. The test-receiver system was set to peak and average detect function and specified bandwidth with maximum hold mode when the test frequency is above 1 GHz. If the peak reading value also meets average limit, measurement with the average detector is unnecessary.

Note:

1. The resolution bandwidth and video bandwidth of test receiver/spectrum analyzer is 120kHz for Quasi-peak detection (QP) at frequency below 1GHz.
2. The resolution bandwidth of test receiver/spectrum analyzer is 1 MHz and the video bandwidth is 3 MHz for Peak detection (PK) at frequency above 1GHz.
3. The resolution bandwidth of test receiver/spectrum analyzer is 1MHz and the video bandwidth is $\geq 1/T$ (Duty cycle < 98%) or 10Hz (Duty cycle $\geq 98\%$) for Average detection (AV) at frequency above 1GHz.
4. All modes of operation were investigated and the worst-case emissions are reported.

4.1.4 Deviation from Test Standard

No deviation.

4.1.5 Test Setup

For Radiated emission below 30MHz

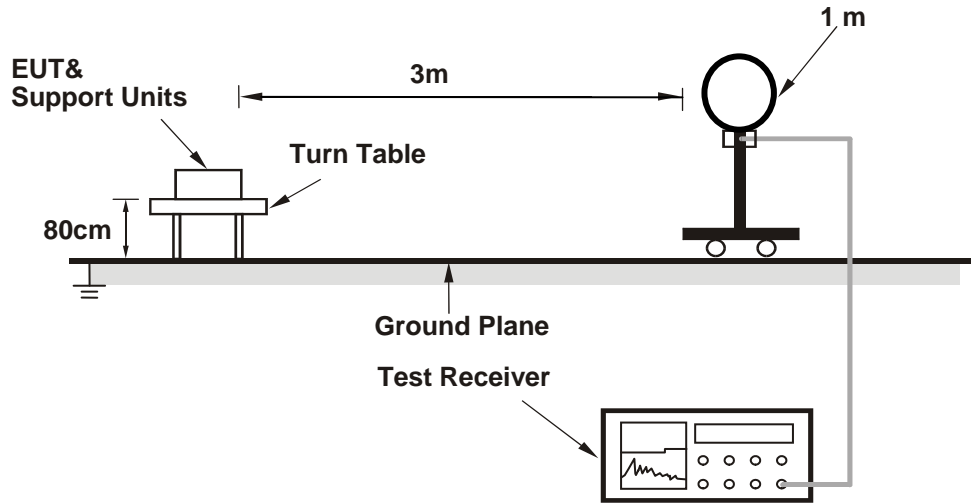

For Radiated emission 30MHz to 1GHz

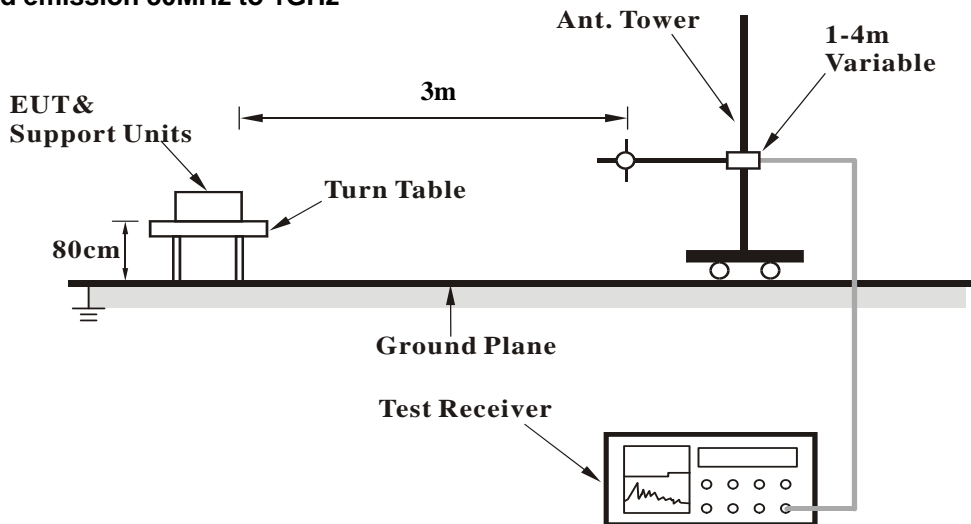

For Radiated emission above 1GHz

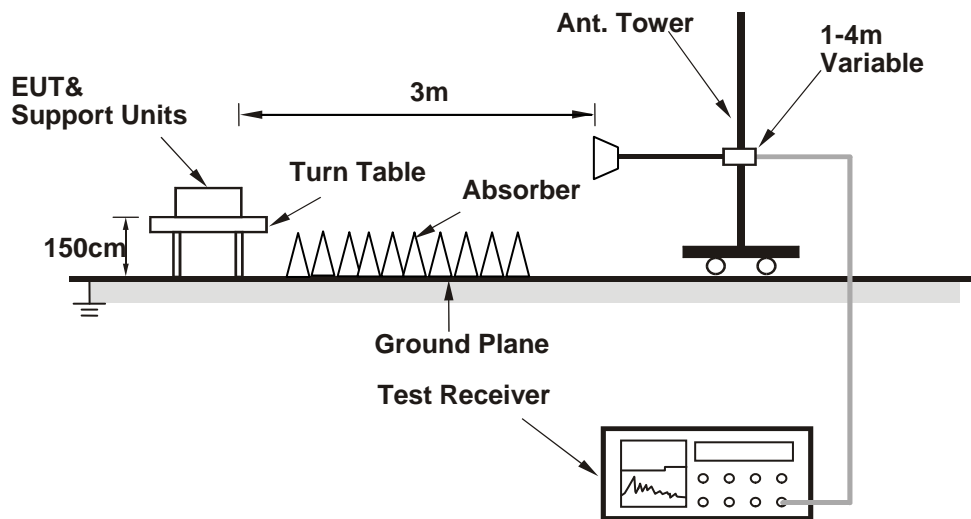

For the actual test configuration, please refer to the attached file (Test Setup Photo).

4.1.6 EUT Operating Conditions

- Placed the EUT on the testing table.
- Prepared a notebook to act as a communication partner and placed it outside of testing area.
- The communication partner connected with EUT via a RJ45 cable and ran a test program (provided by manufacturer) to enable EUT under transmission condition continuously at specific channel frequency.
- The communication partner sent data to EUT by command "PING".

4.1.7 Test Results

Test Mode A

Above 1GHz worst-Case Data:

802.11a

CHANNEL	TX Channel 36	DETECTOR FUNCTION	Peak (PK)
FREQUENCY RANGE	1GHz ~ 40GHz		Average (AV)

ANTENNA POLARITY & TEST DISTANCE: HORIZONTAL AT 3 M								
NO.	FREQ. (MHz)	EMISSION LEVEL (dBuV/m)	LIMIT (dBuV/m)	MARGIN (dB)	ANTENNA HEIGHT (m)	TABLE ANGLE (Degree)	RAW VALUE (dBuV)	CORRECTION FACTOR (dB/m)
1	5150.00	57.6 PK	74.0	-16.4	1.51 H	132	52.8	4.8
2	5150.00	43.8 AV	54.0	-10.2	1.51 H	132	39.0	4.8
3	*5180.00	106.1 PK			1.50 H	131	67.4	38.7
4	*5180.00	95.7 AV			1.50 H	131	57.0	38.7
5	#10360.00	58.4 PK	74.0	-15.6	2.56 H	258	40.8	17.6
6	#10360.00	45.4 AV	54.0	-8.6	2.56 H	258	27.8	17.6

ANTENNA POLARITY & TEST DISTANCE: VERTICAL AT 3 M								
NO.	FREQ. (MHz)	EMISSION LEVEL (dBuV/m)	LIMIT (dBuV/m)	MARGIN (dB)	ANTENNA HEIGHT (m)	TABLE ANGLE (Degree)	RAW VALUE (dBuV)	CORRECTION FACTOR (dB/m)
1	5150.00	68.4 PK	74.0	-5.6	1.67 V	19	63.6	4.8
2	5150.00	51.8 AV	54.0	-2.2	1.67 V	19	47.0	4.8
3	*5180.00	118.4 PK			1.68 V	29	79.7	38.7
4	*5180.00	108.0 AV			1.68 V	29	69.3	38.7
5	#10360.00	59.6 PK	74.0	-14.4	1.85 V	282	42.0	17.6
6	#10360.00	46.6 AV	54.0	-7.4	1.85 V	282	29.0	17.6

Remarks:

1. Emission Level(dBuV/m) = Raw Value(dBuV) + Correction Factor(dB/m)
2. Correction Factor(dB/m) = Antenna Factor(dB/m) + Cable Factor(dB) – Pre-Amplifier Factor(dB)
3. The other emission levels were very low against the limit.
4. Margin value = Emission Level – Limit value
5. " * ": Fundamental frequency.
6. " # ": The radiated frequency is out of the restricted band.

CHANNEL	TX Channel 40	DETECTOR FUNCTION	Peak (PK)
FREQUENCY RANGE	1GHz ~ 40GHz		Average (AV)

ANTENNA POLARITY & TEST DISTANCE: HORIZONTAL AT 3 M								
NO.	FREQ. (MHz)	EMISSION LEVEL (dBuV/m)	LIMIT (dBuV/m)	MARGIN (dB)	ANTENNA HEIGHT (m)	TABLE ANGLE (Degree)	RAW VALUE (dBuV)	CORRECTION FACTOR (dB/m)
1	*5200.00	106.7 PK			1.57 H	131	68.0	38.7
2	*5200.00	96.4 AV			1.57 H	131	57.7	38.7
3	#10400.00	60.2 PK	74.0	-13.8	1.86 H	173	42.6	17.6
4	#10400.00	47.4 AV	54.0	-6.6	1.86 H	173	29.8	17.6
ANTENNA POLARITY & TEST DISTANCE: VERTICAL AT 3 M								
NO.	FREQ. (MHz)	EMISSION LEVEL (dBuV/m)	LIMIT (dBuV/m)	MARGIN (dB)	ANTENNA HEIGHT (m)	TABLE ANGLE (Degree)	RAW VALUE (dBuV)	CORRECTION FACTOR (dB/m)
1	*5200.00	118.5 PK			1.69 V	4	79.8	38.7
2	*5200.00	107.7 AV			1.69 V	4	69.0	38.7
3	#10400.00	59.4 PK	74.0	-14.6	2.04 V	163	41.8	17.6
4	#10400.00	46.0 AV	54.0	-8.0	2.04 V	163	28.4	17.6

Remarks:

1. Emission Level(dBuV/m) = Raw Value(dBuV) + Correction Factor(dB/m)
2. Correction Factor(dB/m) = Antenna Factor(dB/m) + Cable Factor(dB) – Pre-Amplifier Factor(dB)
3. The other emission levels were very low against the limit.
4. Margin value = Emission Level – Limit value
5. " * ": Fundamental frequency.
6. " # ": The radiated frequency is out of the restricted band.

CHANNEL	TX Channel 48	DETECTOR FUNCTION	Peak (PK)
FREQUENCY RANGE	1GHz ~ 40GHz		Average (AV)

ANTENNA POLARITY & TEST DISTANCE: HORIZONTAL AT 3 M

NO.	FREQ. (MHz)	EMISSION LEVEL (dBuV/m)	LIMIT (dBuV/m)	MARGIN (dB)	ANTENNA HEIGHT (m)	TABLE ANGLE (Degree)	RAW VALUE (dBuV)	CORRECTION FACTOR (dB/m)
1	*5240.00	106.5 PK			1.64 H	131	67.6	38.9
2	*5240.00	96.3 AV			1.64 H	131	57.4	38.9
3	5380.00	56.9 PK	74.0	-17.1	1.54 H	134	51.4	5.5
4	5380.00	43.6 AV	54.0	-10.4	1.54 H	134	38.1	5.5
5	#10480.00	60.2 PK	74.0	-13.8	2.08 H	246	41.8	18.4
6	#10480.00	46.2 AV	54.0	-7.8	2.08 H	246	27.8	18.4

ANTENNA POLARITY & TEST DISTANCE: VERTICAL AT 3 M

NO.	FREQ. (MHz)	EMISSION LEVEL (dBuV/m)	LIMIT (dBuV/m)	MARGIN (dB)	ANTENNA HEIGHT (m)	TABLE ANGLE (Degree)	RAW VALUE (dBuV)	CORRECTION FACTOR (dB/m)
1	*5240.00	118.6 PK			1.67 V	35	79.7	38.9
2	*5240.00	108.4 AV			1.67 V	35	69.5	38.9
3	5380.00	58.2 PK	74.0	-15.8	1.60 V	37	52.7	5.5
4	5380.00	46.0 AV	54.0	-8.0	1.60 V	37	40.5	5.5
5	#10460.00	59.7 PK	74.0	-14.3	2.04 V	137	41.5	18.2
6	#10460.00	46.3 AV	54.0	-7.7	2.04 V	137	28.1	18.2

Remarks:

1. Emission Level(dBuV/m) = Raw Value(dBuV) + Correction Factor(dB/m)
2. Correction Factor(dB/m) = Antenna Factor(dB/m) + Cable Factor(dB) – Pre-Amplifier Factor(dB)
3. The other emission levels were very low against the limit.
4. Margin value = Emission Level – Limit value
5. " * ": Fundamental frequency.
6. " # ": The radiated frequency is out of the restricted band.

CHANNEL	TX Channel 149	DETECTOR FUNCTION	Peak (PK)
FREQUENCY RANGE	1GHz ~ 40GHz		Average (AV)

ANTENNA POLARITY & TEST DISTANCE: HORIZONTAL AT 3 M

NO.	FREQ. (MHz)	EMISSION LEVEL (dBuV/m)	LIMIT (dBuV/m)	MARGIN (dB)	ANTENNA HEIGHT (m)	TABLE ANGLE (Degree)	RAW VALUE (dBuV)	CORRECTION FACTOR (dB/m)
1	*5745.00	113.3 PK			1.18 H	129	73.3	40.0
2	*5745.00	103.0 AV			1.18 H	129	63.0	40.0
3	11490.00	61.1 PK	74.0	-12.9	1.48 H	334	41.8	19.3
4	11490.00	48.8 AV	54.0	-5.2	1.48 H	334	29.5	19.3

ANTENNA POLARITY & TEST DISTANCE: VERTICAL AT 3 M

NO.	FREQ. (MHz)	EMISSION LEVEL (dBuV/m)	LIMIT (dBuV/m)	MARGIN (dB)	ANTENNA HEIGHT (m)	TABLE ANGLE (Degree)	RAW VALUE (dBuV)	CORRECTION FACTOR (dB/m)
1	*5745.00	123.0 PK			1.88 V	3	83.0	40.0
2	*5745.00	112.5 AV			1.88 V	3	72.5	40.0
3	11490.00	60.8 PK	74.0	-13.2	1.46 V	284	41.5	19.3
4	11490.00	47.8 AV	54.0	-6.2	1.46 V	284	28.5	19.3

Remarks:

1. Emission Level(dBuV/m) = Raw Value(dBuV) + Correction Factor(dB/m)
2. Correction Factor(dB/m) = Antenna Factor(dB/m) + Cable Factor(dB) – Pre-Amplifier Factor(dB)
3. The other emission levels were very low against the limit.
4. Margin value = Emission Level – Limit value
5. " * ": Fundamental frequency.
6. " # ": The radiated frequency is out of the restricted band.

CHANNEL	TX Channel 157	DETECTOR FUNCTION	Peak (PK)
FREQUENCY RANGE	1GHz ~ 40GHz		Average (AV)

ANTENNA POLARITY & TEST DISTANCE: HORIZONTAL AT 3 M								
NO.	FREQ. (MHz)	EMISSION LEVEL (dBuV/m)	LIMIT (dBuV/m)	MARGIN (dB)	ANTENNA HEIGHT (m)	TABLE ANGLE (Degree)	RAW VALUE (dBuV)	CORRECTION FACTOR (dB/m)
1	*5785.00	112.9 PK			1.35 H	131	72.8	40.1
2	*5785.00	102.8 AV			1.35 H	131	62.7	40.1
3	11570.00	62.9 PK	74.0	-11.1	1.40 H	345	43.7	19.2
4	11570.00	49.9 AV	54.0	-4.1	1.40 H	345	30.7	19.2
ANTENNA POLARITY & TEST DISTANCE: VERTICAL AT 3 M								
NO.	FREQ. (MHz)	EMISSION LEVEL (dBuV/m)	LIMIT (dBuV/m)	MARGIN (dB)	ANTENNA HEIGHT (m)	TABLE ANGLE (Degree)	RAW VALUE (dBuV)	CORRECTION FACTOR (dB/m)
1	*5785.00	124.5 PK			1.60 V	212	84.4	40.1
2	*5785.00	113.8 AV			1.60 V	212	73.7	40.1
3	11570.00	61.6 PK	74.0	-12.4	1.87 V	300	42.4	19.2
4	11570.00	48.9 AV	54.0	-5.1	1.87 V	300	29.7	19.2

Remarks:

1. Emission Level(dBuV/m) = Raw Value(dBuV) + Correction Factor(dB/m)
2. Correction Factor(dB/m) = Antenna Factor(dB/m) + Cable Factor(dB) – Pre-Amplifier Factor(dB)
3. The other emission levels were very low against the limit.
4. Margin value = Emission Level – Limit value
5. " * ": Fundamental frequency.

CHANNEL	TX Channel 165	DETECTOR FUNCTION	Peak (PK)
FREQUENCY RANGE	1GHz ~ 40GHz		Average (AV)

ANTENNA POLARITY & TEST DISTANCE: HORIZONTAL AT 3 M

NO.	FREQ. (MHz)	EMISSION LEVEL (dBuV/m)	LIMIT (dBuV/m)	MARGIN (dB)	ANTENNA HEIGHT (m)	TABLE ANGLE (Degree)	RAW VALUE (dBuV)	CORRECTION FACTOR (dB/m)
1	*5825.00	113.3 PK			1.35 H	132	73.2	40.1
2	*5825.00	102.9 AV			1.35 H	132	62.8	40.1
3	11650.00	66.1 PK	74.0	-7.9	1.44 H	25	46.8	19.3
4	11650.00	52.7 AV	54.0	-1.3	1.44 H	25	33.4	19.3

ANTENNA POLARITY & TEST DISTANCE: VERTICAL AT 3 M

NO.	FREQ. (MHz)	EMISSION LEVEL (dBuV/m)	LIMIT (dBuV/m)	MARGIN (dB)	ANTENNA HEIGHT (m)	TABLE ANGLE (Degree)	RAW VALUE (dBuV)	CORRECTION FACTOR (dB/m)
1	*5825.00	123.7 PK			1.51 V	215	83.6	40.1
2	*5825.00	113.5 AV			1.51 V	215	73.4	40.1
3	11650.00	64.3 PK	74.0	-9.7	1.35 V	358	45.0	19.3
4	11650.00	52.6 AV	54.0	-1.4	1.35 V	358	33.3	19.3

Remarks:

1. Emission Level(dBuV/m) = Raw Value(dBuV) + Correction Factor(dB/m)
2. Correction Factor(dB/m) = Antenna Factor(dB/m) + Cable Factor(dB) – Pre-Amplifier Factor(dB)
3. The other emission levels were very low against the limit.
4. Margin value = Emission Level – Limit value
5. " * ": Fundamental frequency.
6. " # ": The radiated frequency is out of the restricted band.

802.11n (HT20)

CHANNEL	TX Channel 36	DETECTOR FUNCTION	Peak (PK) Average (AV)
FREQUENCY RANGE	1GHz ~ 40GHz		

ANTENNA POLARITY & TEST DISTANCE: HORIZONTAL AT 3 M

NO.	FREQ. (MHz)	EMISSION LEVEL (dBuV/m)	LIMIT (dBuV/m)	MARGIN (dB)	ANTENNA HEIGHT (m)	TABLE ANGLE (Degree)	RAW VALUE (dBuV)	CORRECTION FACTOR (dB/m)
1	5150.00	55.8 PK	74.0	-18.2	1.58 H	124	51.0	4.8
2	5150.00	42.8 AV	54.0	-11.2	1.58 H	124	38.0	4.8
3	*5180.00	106.1 PK			1.41 H	129	67.4	38.7
4	*5180.00	95.7 AV			1.41 H	129	57.0	38.7
5	#10360.00	59.3 PK	74.0	-14.7	1.73 H	284	41.7	17.6
6	#10360.00	45.9 AV	54.0	-8.1	1.73 H	284	28.3	17.6

ANTENNA POLARITY & TEST DISTANCE: VERTICAL AT 3 M

NO.	FREQ. (MHz)	EMISSION LEVEL (dBuV/m)	LIMIT (dBuV/m)	MARGIN (dB)	ANTENNA HEIGHT (m)	TABLE ANGLE (Degree)	RAW VALUE (dBuV)	CORRECTION FACTOR (dB/m)
1	5150.00	66.8 PK	74.0	-7.2	1.49 V	32	62.0	4.8
2	5150.00	51.2 AV	54.0	-2.8	1.49 V	32	46.4	4.8
3	*5180.00	118.8 PK			1.52 V	23	80.1	38.7
4	*5180.00	108.0 AV			1.52 V	23	69.3	38.7
5	#10360.00	58.8 PK	74.0	-15.2	2.96 V	263	41.2	17.6
6	#10360.00	46.0 AV	54.0	-8.0	2.96 V	263	28.4	17.6

Remarks:

1. Emission Level(dBuV/m) = Raw Value(dBuV) + Correction Factor(dB/m)
2. Correction Factor(dB/m) = Antenna Factor(dB/m) + Cable Factor(dB) – Pre-Amplifier Factor(dB)
3. The other emission levels were very low against the limit.
4. Margin value = Emission Level – Limit value
5. " * ": Fundamental frequency.
6. " # ": The radiated frequency is out of the restricted band.

CHANNEL	TX Channel 40	DETECTOR FUNCTION	Peak (PK)
FREQUENCY RANGE	1GHz ~ 40GHz		Average (AV)

ANTENNA POLARITY & TEST DISTANCE: HORIZONTAL AT 3 M

NO.	FREQ. (MHz)	EMISSION LEVEL (dBuV/m)	LIMIT (dBuV/m)	MARGIN (dB)	ANTENNA HEIGHT (m)	TABLE ANGLE (Degree)	RAW VALUE (dBuV)	CORRECTION FACTOR (dB/m)
1	*5200.00	107.3 PK			1.57 H	130	68.6	38.7
2	*5200.00	96.5 AV			1.57 H	130	57.8	38.7
3	#10400.00	59.5 PK	74.0	-14.5	2.56 H	186	41.9	17.6
4	#10400.00	46.1 AV	54.0	-7.9	2.56 H	186	28.5	17.6

ANTENNA POLARITY & TEST DISTANCE: VERTICAL AT 3 M

NO.	FREQ. (MHz)	EMISSION LEVEL (dBuV/m)	LIMIT (dBuV/m)	MARGIN (dB)	ANTENNA HEIGHT (m)	TABLE ANGLE (Degree)	RAW VALUE (dBuV)	CORRECTION FACTOR (dB/m)
1	*5200.00	118.6 PK			1.90 V	47	79.9	38.7
2	*5200.00	107.6 AV			1.90 V	47	68.9	38.7
3	#10400.00	59.4 PK	74.0	-14.6	1.83 V	200	41.8	17.6
4	#10400.00	46.0 AV	54.0	-8.0	1.83 V	200	28.4	17.6

Remarks:

1. Emission Level(dBuV/m) = Raw Value(dBuV) + Correction Factor(dB/m)
2. Correction Factor(dB/m) = Antenna Factor(dB/m) + Cable Factor(dB) – Pre-Amplifier Factor(dB)
3. The other emission levels were very low against the limit.
4. Margin value = Emission Level – Limit value
5. " * ": Fundamental frequency.
6. " # ": The radiated frequency is out of the restricted band.

CHANNEL	TX Channel 48	DETECTOR FUNCTION	Peak (PK)
FREQUENCY RANGE	1GHz ~ 40GHz		Average (AV)

ANTENNA POLARITY & TEST DISTANCE: HORIZONTAL AT 3 M								
NO.	FREQ. (MHz)	EMISSION LEVEL (dBuV/m)	LIMIT (dBuV/m)	MARGIN (dB)	ANTENNA HEIGHT (m)	TABLE ANGLE (Degree)	RAW VALUE (dBuV)	CORRECTION FACTOR (dB/m)
1	*5240.00	107.7 PK			1.66 H	129	68.8	38.9
2	*5240.00	97.3 AV			1.66 H	129	58.4	38.9
3	5350.00	57.1 PK	74.0	-16.9	1.72 H	135	51.6	5.5
4	5350.00	43.8 AV	54.0	-10.2	1.72 H	135	38.3	5.5
5	#10480.00	59.6 PK	74.0	-14.4	2.55 H	320	41.2	18.4
6	#10480.00	46.8 AV	54.0	-7.2	2.55 H	320	28.4	18.4

ANTENNA POLARITY & TEST DISTANCE: VERTICAL AT 3 M								
NO.	FREQ. (MHz)	EMISSION LEVEL (dBuV/m)	LIMIT (dBuV/m)	MARGIN (dB)	ANTENNA HEIGHT (m)	TABLE ANGLE (Degree)	RAW VALUE (dBuV)	CORRECTION FACTOR (dB/m)
1	*5240.00	120.1 PK			1.72 V	10	81.2	38.9
2	*5240.00	108.6 AV			1.72 V	10	69.7	38.9
3	5350.00	58.2 PK	74.0	-15.8	1.70 V	27	52.7	5.5
4	5350.00	45.0 AV	54.0	-9.0	1.70 V	27	39.5	5.5
5	#10480.00	59.5 PK	74.0	-14.5	2.43 V	301	41.1	18.4
6	#10480.00	46.4 AV	54.0	-7.6	2.43 V	301	28.0	18.4

Remarks:

1. Emission Level(dBuV/m) = Raw Value(dBuV) + Correction Factor(dB/m)
2. Correction Factor(dB/m) = Antenna Factor(dB/m) + Cable Factor(dB) – Pre-Amplifier Factor(dB)
3. The other emission levels were very low against the limit.
4. Margin value = Emission Level – Limit value
5. " * ": Fundamental frequency.
6. " # ": The radiated frequency is out of the restricted band.

CHANNEL	TX Channel 149	DETECTOR FUNCTION	Peak (PK)
FREQUENCY RANGE	1GHz ~ 40GHz		Average (AV)

ANTENNA POLARITY & TEST DISTANCE: HORIZONTAL AT 3 M

NO.	FREQ. (MHz)	EMISSION LEVEL (dBuV/m)	LIMIT (dBuV/m)	MARGIN (dB)	ANTENNA HEIGHT (m)	TABLE ANGLE (Degree)	RAW VALUE (dBuV)	CORRECTION FACTOR (dB/m)
1	*5745.00	109.5 PK			1.50 H	236	69.5	40.0
2	*5745.00	98.9 AV			1.50 H	236	58.9	40.0
3	11490.00	60.9 PK	74.0	-13.1	1.57 H	283	41.6	19.3
4	11490.00	48.8 AV	54.0	-5.2	1.57 H	283	29.5	19.3

ANTENNA POLARITY & TEST DISTANCE: VERTICAL AT 3 M

NO.	FREQ. (MHz)	EMISSION LEVEL (dBuV/m)	LIMIT (dBuV/m)	MARGIN (dB)	ANTENNA HEIGHT (m)	TABLE ANGLE (Degree)	RAW VALUE (dBuV)	CORRECTION FACTOR (dB/m)
1	*5745.00	124.9 PK			1.43 V	216	84.9	40.0
2	*5745.00	113.5 AV			1.43 V	216	73.5	40.0
3	11490.00	60.2 PK	74.0	-13.8	1.27 V	40	40.9	19.3
4	11490.00	48.3 AV	54.0	-5.7	1.27 V	40	29.0	19.3

Remarks:

1. Emission Level(dBuV/m) = Raw Value(dBuV) + Correction Factor(dB/m)
2. Correction Factor(dB/m) = Antenna Factor(dB/m) + Cable Factor(dB) – Pre-Amplifier Factor(dB)
3. The other emission levels were very low against the limit.
4. Margin value = Emission Level – Limit value
5. " * ": Fundamental frequency.
6. " # ": The radiated frequency is out of the restricted band.

CHANNEL	TX Channel 157	DETECTOR FUNCTION	Peak (PK)
FREQUENCY RANGE	1GHz ~ 40GHz		Average (AV)

ANTENNA POLARITY & TEST DISTANCE: HORIZONTAL AT 3 M								
NO.	FREQ. (MHz)	EMISSION LEVEL (dBuV/m)	LIMIT (dBuV/m)	MARGIN (dB)	ANTENNA HEIGHT (m)	TABLE ANGLE (Degree)	RAW VALUE (dBuV)	CORRECTION FACTOR (dB/m)
1	*5785.00	112.4 PK			1.11 H	130	72.3	40.1
2	*5785.00	101.3 AV			1.11 H	130	61.2	40.1
3	11570.00	62.3 PK	74.0	-11.7	1.49 H	283	43.1	19.2
4	11570.00	50.1 AV	54.0	-3.9	1.49 H	283	30.9	19.2
ANTENNA POLARITY & TEST DISTANCE: VERTICAL AT 3 M								
NO.	FREQ. (MHz)	EMISSION LEVEL (dBuV/m)	LIMIT (dBuV/m)	MARGIN (dB)	ANTENNA HEIGHT (m)	TABLE ANGLE (Degree)	RAW VALUE (dBuV)	CORRECTION FACTOR (dB/m)
1	*5785.00	125.2 PK			1.39 V	216	85.1	40.1
2	*5785.00	114.0 AV			1.39 V	216	73.9	40.1
3	11570.00	61.8 PK	74.0	-12.2	1.27 V	55	42.6	19.2
4	11570.00	49.2 AV	54.0	-4.8	1.27 V	55	30.0	19.2

Remarks:

1. Emission Level(dBuV/m) = Raw Value(dBuV) + Correction Factor(dB/m)
2. Correction Factor(dB/m) = Antenna Factor(dB/m) + Cable Factor(dB) – Pre-Amplifier Factor(dB)
3. The other emission levels were very low against the limit.
4. Margin value = Emission Level – Limit value
5. " * ": Fundamental frequency.

CHANNEL	TX Channel 165	DETECTOR FUNCTION	Peak (PK)
FREQUENCY RANGE	1GHz ~ 40GHz		Average (AV)

ANTENNA POLARITY & TEST DISTANCE: HORIZONTAL AT 3 M								
NO.	FREQ. (MHz)	EMISSION LEVEL (dBuV/m)	LIMIT (dBuV/m)	MARGIN (dB)	ANTENNA HEIGHT (m)	TABLE ANGLE (Degree)	RAW VALUE (dBuV)	CORRECTION FACTOR (dB/m)
1	*5825.00	112.6 PK			1.22 H	133	72.5	40.1
2	*5825.00	101.8 AV			1.22 H	133	61.7	40.1
3	11650.00	62.5 PK	74.0	-11.5	1.28 H	345	43.2	19.3
4	11650.00	49.6 AV	54.0	-4.4	1.28 H	345	30.3	19.3
ANTENNA POLARITY & TEST DISTANCE: VERTICAL AT 3 M								
NO.	FREQ. (MHz)	EMISSION LEVEL (dBuV/m)	LIMIT (dBuV/m)	MARGIN (dB)	ANTENNA HEIGHT (m)	TABLE ANGLE (Degree)	RAW VALUE (dBuV)	CORRECTION FACTOR (dB/m)
1	*5825.00	123.9 PK			1.48 V	213	83.8	40.1
2	*5825.00	113.5 AV			1.48 V	213	73.4	40.1
3	11650.00	62.4 PK	74.0	-11.6	1.35 V	66	43.1	19.3
4	11650.00	49.7 AV	54.0	-4.3	1.35 V	66	30.4	19.3

Remarks:

1. Emission Level(dBuV/m) = Raw Value(dBuV) + Correction Factor(dB/m)
2. Correction Factor(dB/m) = Antenna Factor(dB/m) + Cable Factor(dB) – Pre-Amplifier Factor(dB)
3. The other emission levels were very low against the limit.
4. Margin value = Emission Level – Limit value
5. " * ": Fundamental frequency.
6. " # ": The radiated frequency is out of the restricted band.

802.11n (HT40)

CHANNEL	TX Channel 38	DETECTOR FUNCTION	Peak (PK) Average (AV)
FREQUENCY RANGE	1GHz ~ 40GHz		

ANTENNA POLARITY & TEST DISTANCE: HORIZONTAL AT 3 M

NO.	FREQ. (MHz)	EMISSION LEVEL (dBuV/m)	LIMIT (dBuV/m)	MARGIN (dB)	ANTENNA HEIGHT (m)	TABLE ANGLE (Degree)	RAW VALUE (dBuV)	CORRECTION FACTOR (dB/m)
1	5150.00	58.2 PK	74.0	-15.8	1.31 H	133	53.4	4.8
2	5150.00	44.5 AV	54.0	-9.5	1.31 H	133	39.7	4.8
3	*5190.00	100.2 PK			1.19 H	128	61.5	38.7
4	*5190.00	90.2 AV			1.19 H	128	51.5	38.7
5	#10380.00	59.0 PK	74.0	-15.0	2.54 H	269	41.4	17.6
6	#10380.00	46.5 AV	54.0	-7.5	2.54 H	269	28.9	17.6

ANTENNA POLARITY & TEST DISTANCE: VERTICAL AT 3 M

NO.	FREQ. (MHz)	EMISSION LEVEL (dBuV/m)	LIMIT (dBuV/m)	MARGIN (dB)	ANTENNA HEIGHT (m)	TABLE ANGLE (Degree)	RAW VALUE (dBuV)	CORRECTION FACTOR (dB/m)
1	5150.00	67.0 PK	74.0	-7.0	1.61 V	50	62.2	4.8
2	5150.00	52.7 AV	54.0	-1.3	1.61 V	50	47.9	4.8
3	*5190.00	112.0 PK			1.69 V	29	73.3	38.7
4	*5190.00	102.2 AV			1.69 V	29	63.5	38.7
5	#10380.00	60.1 PK	74.0	-13.9	1.72 V	253	42.5	17.6
6	#10380.00	46.0 AV	54.0	-8.0	1.72 V	253	28.4	17.6

Remarks:

1. Emission Level(dBuV/m) = Raw Value(dBuV) + Correction Factor(dB/m)
2. Correction Factor(dB/m) = Antenna Factor(dB/m) + Cable Factor(dB) – Pre-Amplifier Factor(dB)
3. The other emission levels were very low against the limit.
4. Margin value = Emission Level – Limit value
5. " * ": Fundamental frequency.
6. " # ": The radiated frequency is out of the restricted band.

CHANNEL	TX Channel 46	DETECTOR FUNCTION	Peak (PK)
FREQUENCY RANGE	1GHz ~ 40GHz		Average (AV)

ANTENNA POLARITY & TEST DISTANCE: HORIZONTAL AT 3 M								
NO.	FREQ. (MHz)	EMISSION LEVEL (dBuV/m)	LIMIT (dBuV/m)	MARGIN (dB)	ANTENNA HEIGHT (m)	TABLE ANGLE (Degree)	RAW VALUE (dBuV)	CORRECTION FACTOR (dB/m)
1	5150.00	55.8 PK	74.0	-18.2	1.85 H	115	51.0	4.8
2	5150.00	42.5 AV	54.0	-11.5	1.85 H	115	37.7	4.8
3	*5230.00	103.8 PK			1.48 H	131	64.9	38.9
4	*5230.00	94.2 AV			1.48 H	131	55.3	38.9
5	#10460.00	59.2 PK	74.0	-14.8	2.43 H	186	41.0	18.2
6	#10460.00	46.7 AV	54.0	-7.3	2.43 H	186	28.5	18.2

ANTENNA POLARITY & TEST DISTANCE: VERTICAL AT 3 M								
NO.	FREQ. (MHz)	EMISSION LEVEL (dBuV/m)	LIMIT (dBuV/m)	MARGIN (dB)	ANTENNA HEIGHT (m)	TABLE ANGLE (Degree)	RAW VALUE (dBuV)	CORRECTION FACTOR (dB/m)
1	5150.00	57.8 PK	74.0	-16.2	1.62 V	57	53.0	4.8
2	5150.00	45.3 AV	54.0	-8.7	1.62 V	57	40.5	4.8
3	*5230.00	115.3 PK			1.55 V	39	76.4	38.9
4	*5230.00	105.9 AV			1.55 V	39	67.0	38.9
5	#10460.00	58.9 PK	74.0	-15.1	1.86 V	288	40.7	18.2
6	#10460.00	46.3 AV	54.0	-7.7	1.86 V	288	28.1	18.2

Remarks:

1. Emission Level(dBuV/m) = Raw Value(dBuV) + Correction Factor(dB/m)
2. Correction Factor(dB/m) = Antenna Factor(dB/m) + Cable Factor(dB) – Pre-Amplifier Factor(dB)
3. The other emission levels were very low against the limit.
4. Margin value = Emission Level – Limit value
5. " * ": Fundamental frequency.
6. " # ": The radiated frequency is out of the restricted band.

CHANNEL	TX Channel 151	DETECTOR FUNCTION	Peak (PK)
FREQUENCY RANGE	1GHz ~ 40GHz		Average (AV)

ANTENNA POLARITY & TEST DISTANCE: HORIZONTAL AT 3 M								
NO.	FREQ. (MHz)	EMISSION LEVEL (dBuV/m)	LIMIT (dBuV/m)	MARGIN (dB)	ANTENNA HEIGHT (m)	TABLE ANGLE (Degree)	RAW VALUE (dBuV)	CORRECTION FACTOR (dB/m)
1	*5755.00	108.7 PK			1.17 H	131	68.7	40.0
2	*5755.00	99.1 AV			1.17 H	131	59.1	40.0
3	11510.00	60.8 PK	74.0	-13.2	1.04 H	344	41.5	19.3
4	11510.00	47.8 AV	54.0	-6.2	1.04 H	344	28.5	19.3
ANTENNA POLARITY & TEST DISTANCE: VERTICAL AT 3 M								
NO.	FREQ. (MHz)	EMISSION LEVEL (dBuV/m)	LIMIT (dBuV/m)	MARGIN (dB)	ANTENNA HEIGHT (m)	TABLE ANGLE (Degree)	RAW VALUE (dBuV)	CORRECTION FACTOR (dB/m)
1	*5755.00	120.9 PK			1.36 V	216	80.9	40.0
2	*5755.00	111.4 AV			1.36 V	216	71.4	40.0
3	11510.00	60.5 PK	74.0	-13.5	1.42 V	13	41.2	19.3
4	11510.00	47.8 AV	54.0	-6.2	1.42 V	13	28.5	19.3

Remarks:

1. Emission Level(dBuV/m) = Raw Value(dBuV) + Correction Factor(dB/m)
2. Correction Factor(dB/m) = Antenna Factor(dB/m) + Cable Factor(dB) – Pre-Amplifier Factor(dB)
3. The other emission levels were very low against the limit.
4. Margin value = Emission Level – Limit value
5. " * ": Fundamental frequency.
6. " # ": The radiated frequency is out of the restricted band.

CHANNEL	TX Channel 159	DETECTOR FUNCTION	Peak (PK)
FREQUENCY RANGE	1GHz ~ 40GHz		Average (AV)

ANTENNA POLARITY & TEST DISTANCE: HORIZONTAL AT 3 M

NO.	FREQ. (MHz)	EMISSION LEVEL (dBuV/m)	LIMIT (dBuV/m)	MARGIN (dB)	ANTENNA HEIGHT (m)	TABLE ANGLE (Degree)	RAW VALUE (dBuV)	CORRECTION FACTOR (dB/m)
1	*5795.00	109.0 PK			1.34 H	129	68.9	40.1
2	*5795.00	99.1 AV			1.34 H	129	59.0	40.1
3	11590.00	62.2 PK	74.0	-11.8	1.53 H	282	43.0	19.2
4	11590.00	49.1 AV	54.0	-4.9	1.53 H	282	29.9	19.2

ANTENNA POLARITY & TEST DISTANCE: VERTICAL AT 3 M

NO.	FREQ. (MHz)	EMISSION LEVEL (dBuV/m)	LIMIT (dBuV/m)	MARGIN (dB)	ANTENNA HEIGHT (m)	TABLE ANGLE (Degree)	RAW VALUE (dBuV)	CORRECTION FACTOR (dB/m)
1	*5795.00	120.8 PK			1.45 V	215	80.7	40.1
2	*5795.00	111.4 AV			1.45 V	215	71.3	40.1
3	11590.00	60.5 PK	74.0	-13.5	1.34 V	346	41.3	19.2
4	11590.00	48.3 AV	54.0	-5.7	1.34 V	346	29.1	19.2

Remarks:

1. Emission Level(dBuV/m) = Raw Value(dBuV) + Correction Factor(dB/m)
2. Correction Factor(dB/m) = Antenna Factor(dB/m) + Cable Factor(dB) – Pre-Amplifier Factor(dB)
3. The other emission levels were very low against the limit.
4. Margin value = Emission Level – Limit value
5. " * ": Fundamental frequency.
6. " # ": The radiated frequency is out of the restricted band.

802.11ac (VHT80)

CHANNEL	TX Channel 42	DETECTOR FUNCTION	Peak (PK) Average (AV)
FREQUENCY RANGE	1GHz ~ 40GHz		

ANTENNA POLARITY & TEST DISTANCE: HORIZONTAL AT 3 M

NO.	FREQ. (MHz)	EMISSION LEVEL (dBuV/m)	LIMIT (dBuV/m)	MARGIN (dB)	ANTENNA HEIGHT (m)	TABLE ANGLE (Degree)	RAW VALUE (dBuV)	CORRECTION FACTOR (dB/m)
1	5150.00	57.6 PK	74.0	-16.4	1.53 H	131	52.8	4.8
2	5150.00	44.3 AV	54.0	-9.7	1.53 H	131	39.5	4.8
3	*5210.00	94.1 PK			1.49 H	131	55.4	38.7
4	*5210.00	84.2 AV			1.49 H	131	45.5	38.7
5	#10420.00	59.7 PK	74.0	-14.3	1.68 H	228	41.9	17.8
6	#10420.00	46.4 AV	54.0	-7.6	1.68 H	228	28.6	17.8

ANTENNA POLARITY & TEST DISTANCE: VERTICAL AT 3 M

NO.	FREQ. (MHz)	EMISSION LEVEL (dBuV/m)	LIMIT (dBuV/m)	MARGIN (dB)	ANTENNA HEIGHT (m)	TABLE ANGLE (Degree)	RAW VALUE (dBuV)	CORRECTION FACTOR (dB/m)
1	5150.00	65.8 PK	74.0	-8.2	1.82 V	22	61.0	4.8
2	5150.00	52.6 AV	54.0	-1.4	1.82 V	22	47.8	4.8
3	*5210.00	106.9 PK			1.62 V	39	68.2	38.7
4	*5210.00	96.6 AV			1.62 V	39	57.9	38.7
5	#10420.00	59.5 PK	74.0	-14.5	1.76 V	284	41.7	17.8
6	#10420.00	46.4 AV	54.0	-7.6	1.76 V	284	28.6	17.8

Remarks:

1. Emission Level(dBuV/m) = Raw Value(dBuV) + Correction Factor(dB/m)
2. Correction Factor(dB/m) = Antenna Factor(dB/m) + Cable Factor(dB) – Pre-Amplifier Factor(dB)
3. The other emission levels were very low against the limit.
4. Margin value = Emission Level – Limit value
5. " * ": Fundamental frequency.
6. " # ": The radiated frequency is out of the restricted band.

CHANNEL	TX Channel 155	DETECTOR FUNCTION	Peak (PK)
FREQUENCY RANGE	1GHz ~ 40GHz		Average (AV)

ANTENNA POLARITY & TEST DISTANCE: HORIZONTAL AT 3 M								
NO.	FREQ. (MHz)	EMISSION LEVEL (dBuV/m)	LIMIT (dBuV/m)	MARGIN (dB)	ANTENNA HEIGHT (m)	TABLE ANGLE (Degree)	RAW VALUE (dBuV)	CORRECTION FACTOR (dB/m)
1	*5775.00	101.9 PK			1.19 H	133	61.9	40.0
2	*5775.00	91.7 AV			1.19 H	133	51.7	40.0
3	11550.00	59.7 PK	74.0	-14.3	1.32 H	342	40.5	19.2
4	11550.00	47.3 AV	54.0	-6.7	1.32 H	342	28.1	19.2
ANTENNA POLARITY & TEST DISTANCE: VERTICAL AT 3 M								
NO.	FREQ. (MHz)	EMISSION LEVEL (dBuV/m)	LIMIT (dBuV/m)	MARGIN (dB)	ANTENNA HEIGHT (m)	TABLE ANGLE (Degree)	RAW VALUE (dBuV)	CORRECTION FACTOR (dB/m)
1	*5775.00	112.8 PK			1.59 V	210	72.8	40.0
2	*5775.00	102.9 AV			1.59 V	210	62.9	40.0
3	11550.00	59.8 PK	74.0	-14.2	1.61 V	347	40.6	19.2
4	11550.00	47.4 AV	54.0	-6.6	1.61 V	347	28.2	19.2

Remarks:

1. Emission Level(dBuV/m) = Raw Value(dBuV) + Correction Factor(dB/m)
2. Correction Factor(dB/m) = Antenna Factor(dB/m) + Cable Factor(dB) – Pre-Amplifier Factor(dB)
3. The other emission levels were very low against the limit.
4. Margin value = Emission Level – Limit value
5. " * ": Fundamental frequency.
6. " # ": The radiated frequency is out of the restricted band.

Below 1GHz Worst-Case Data:

802.11a

CHANNEL	TX Channel 149	DETECTOR FUNCTION	Quasi-Peak (QP)
FREQUENCY RANGE	9kHz ~ 1GHz		

ANTENNA POLARITY & TEST DISTANCE: HORIZONTAL AT 3 M								
NO.	FREQ. (MHz)	EMISSION LEVEL (dBuV/m)	LIMIT (dBuV/m)	MARGIN (dB)	ANTENNA HEIGHT (m)	TABLE ANGLE (Degree)	RAW VALUE (dBuV)	CORRECTION FACTOR (dB/m)
1	57.12	28.6 QP	40.0	-11.4	2.00 H	254	43.2	-14.6
2	187.39	29.8 QP	43.5	-13.7	1.00 H	269	45.7	-15.9
3	249.60	35.2 QP	46.0	-10.8	1.00 H	136	49.2	-14.0
4	374.04	37.9 QP	46.0	-8.1	1.00 H	140	48.4	-10.5
5	624.85	36.8 QP	46.0	-9.2	1.00 H	359	41.5	-4.7
6	875.67	44.1 QP	46.0	-1.9	2.00 H	328	44.2	-0.1
ANTENNA POLARITY & TEST DISTANCE: VERTICAL AT 3 M								
NO.	FREQ. (MHz)	EMISSION LEVEL (dBuV/m)	LIMIT (dBuV/m)	MARGIN (dB)	ANTENNA HEIGHT (m)	TABLE ANGLE (Degree)	RAW VALUE (dBuV)	CORRECTION FACTOR (dB/m)
1	57.12	36.6 QP	40.0	-3.4	1.50 V	16	51.2	-14.6
2	101.84	29.8 QP	43.5	-13.7	1.00 V	69	48.2	-18.4
3	183.50	27.7 QP	43.5	-15.8	1.00 V	127	43.2	-15.5
4	249.60	35.4 QP	46.0	-10.6	2.00 V	172	49.4	-14.0
5	374.04	41.4 QP	46.0	-4.6	1.00 V	199	51.9	-10.5
6	875.67	43.3 QP	46.0	-2.7	1.00 V	5	43.4	-0.1

Remarks:

1. Emission Level(dBuV/m) = Raw Value(dBuV) + Correction Factor(dB/m)
2. Correction Factor(dB/m) = Antenna Factor(dB/m) + Cable Factor(dB) – Pre-Amplifier Factor(dB)
3. The other emission levels were very low against the limit.
4. Margin value = Emission Level – Limit value

Test Mode B

Above 1GHz worst-Case Data:

802.11a

CHANNEL	TX Channel 36	DETECTOR FUNCTION	Peak (PK)
FREQUENCY RANGE	1GHz ~ 40GHz		Average (AV)

ANTENNA POLARITY & TEST DISTANCE: HORIZONTAL AT 3 M

NO.	FREQ. (MHz)	EMISSION LEVEL (dBuV/m)	LIMIT (dBuV/m)	MARGIN (dB)	ANTENNA HEIGHT (m)	TABLE ANGLE (Degree)	RAW VALUE (dBuV)	CORRECTION FACTOR (dB/m)
1	5135.00	58.2 PK	74.0	-15.8	1.57 H	344	53.4	4.8
2	5135.00	45.4 AV	54.0	-8.6	1.57 H	344	40.6	4.8
3	*5180.00	109.8 PK			1.57 H	351	71.1	38.7
4	*5180.00	99.0 AV			1.57 H	351	60.3	38.7
5	#10360.00	59.0 PK	74.0	-15.0	1.41 H	243	41.4	17.6
6	#10360.00	46.2 AV	54.0	-7.8	1.41 H	243	28.6	17.6

ANTENNA POLARITY & TEST DISTANCE: VERTICAL AT 3 M

NO.	FREQ. (MHz)	EMISSION LEVEL (dBuV/m)	LIMIT (dBuV/m)	MARGIN (dB)	ANTENNA HEIGHT (m)	TABLE ANGLE (Degree)	RAW VALUE (dBuV)	CORRECTION FACTOR (dB/m)
1	5135.00	57.3 PK	74.0	-16.7	1.81 V	352	52.5	4.8
2	5135.00	46.6 AV	54.0	-7.4	1.81 V	352	41.8	4.8
3	*5180.00	108.0 PK			1.80 V	357	69.3	38.7
4	*5180.00	97.0 AV			1.80 V	357	58.3	38.7
5	#10360.00	59.0 PK	74.0	-15.0	1.69 V	233	41.4	17.6
6	#10360.00	46.2 AV	54.0	-7.8	1.69 V	233	28.6	17.6

Remarks:

1. Emission Level(dBuV/m) = Raw Value(dBuV) + Correction Factor(dB/m)
2. Correction Factor(dB/m) = Antenna Factor(dB/m) + Cable Factor(dB) – Pre-Amplifier Factor(dB)
3. The other emission levels were very low against the limit.
4. Margin value = Emission Level – Limit value
5. " * ": Fundamental frequency.
6. " # ": The radiated frequency is out of the restricted band.

CHANNEL	TX Channel 40	DETECTOR FUNCTION	Peak (PK)
FREQUENCY RANGE	1GHz ~ 40GHz		Average (AV)

ANTENNA POLARITY & TEST DISTANCE: HORIZONTAL AT 3 M								
NO.	FREQ. (MHz)	EMISSION LEVEL (dBuV/m)	LIMIT (dBuV/m)	MARGIN (dB)	ANTENNA HEIGHT (m)	TABLE ANGLE (Degree)	RAW VALUE (dBuV)	CORRECTION FACTOR (dB/m)
1	*5200.00	109.3 PK			1.68 H	346	70.6	38.7
2	*5200.00	99.2 AV			1.68 H	346	60.5	38.7
3	#10400.00	59.1 PK	74.0	-14.9	1.55 H	294	41.5	17.6
4	#10400.00	46.2 AV	54.0	-7.8	1.55 H	294	28.6	17.6
ANTENNA POLARITY & TEST DISTANCE: VERTICAL AT 3 M								
NO.	FREQ. (MHz)	EMISSION LEVEL (dBuV/m)	LIMIT (dBuV/m)	MARGIN (dB)	ANTENNA HEIGHT (m)	TABLE ANGLE (Degree)	RAW VALUE (dBuV)	CORRECTION FACTOR (dB/m)
1	*5200.00	107.9 PK			1.81 V	352	69.2	38.7
2	*5200.00	97.1 AV			1.81 V	352	58.4	38.7
3	#10400.00	59.4 PK	74.0	-14.6	1.77 V	300	41.8	17.6
4	#10400.00	46.4 AV	54.0	-7.6	1.77 V	300	28.8	17.6

Remarks:

1. Emission Level(dBuV/m) = Raw Value(dBuV) + Correction Factor(dB/m)
2. Correction Factor(dB/m) = Antenna Factor(dB/m) + Cable Factor(dB) – Pre-Amplifier Factor(dB)
3. The other emission levels were very low against the limit.
4. Margin value = Emission Level – Limit value
5. " * ": Fundamental frequency.
6. " # ": The radiated frequency is out of the restricted band.

CHANNEL	TX Channel 48	DETECTOR FUNCTION	Peak (PK)
FREQUENCY RANGE	1GHz ~ 40GHz		Average (AV)

ANTENNA POLARITY & TEST DISTANCE: HORIZONTAL AT 3 M

NO.	FREQ. (MHz)	EMISSION LEVEL (dBuV/m)	LIMIT (dBuV/m)	MARGIN (dB)	ANTENNA HEIGHT (m)	TABLE ANGLE (Degree)	RAW VALUE (dBuV)	CORRECTION FACTOR (dB/m)
1	*5240.00	109.8 PK			1.63 H	349	70.9	38.9
2	*5240.00	99.5 AV			1.63 H	349	60.6	38.9
3	5350.00	57.6 PK	74.0	-16.4	1.72 H	358	52.1	5.5
4	5350.00	45.9 AV	54.0	-8.1	1.72 H	358	40.4	5.5
5	#10480.00	59.8 PK	74.0	-14.2	1.64 H	281	41.4	18.4
6	#10480.00	46.6 AV	54.0	-7.4	1.64 H	281	28.2	18.4

ANTENNA POLARITY & TEST DISTANCE: VERTICAL AT 3 M

NO.	FREQ. (MHz)	EMISSION LEVEL (dBuV/m)	LIMIT (dBuV/m)	MARGIN (dB)	ANTENNA HEIGHT (m)	TABLE ANGLE (Degree)	RAW VALUE (dBuV)	CORRECTION FACTOR (dB/m)
1	*5240.00	107.7 PK			1.85 V	339	68.8	38.9
2	*5240.00	96.8 AV			1.85 V	339	57.9	38.9
3	5350.00	58.2 PK	74.0	-15.8	1.90 V	325	52.7	5.5
4	5350.00	45.4 AV	54.0	-8.6	1.90 V	325	39.9	5.5
5	#10480.00	60.2 PK	74.0	-13.8	1.72 V	215	41.8	18.4
6	#10480.00	46.6 AV	54.0	-7.4	1.72 V	215	28.2	18.4

Remarks:

1. Emission Level(dBuV/m) = Raw Value(dBuV) + Correction Factor(dB/m)
2. Correction Factor(dB/m) = Antenna Factor(dB/m) + Cable Factor(dB) – Pre-Amplifier Factor(dB)
3. The other emission levels were very low against the limit.
4. Margin value = Emission Level – Limit value
5. " * ": Fundamental frequency.
6. " # ": The radiated frequency is out of the restricted band.

CHANNEL	TX Channel 149	DETECTOR FUNCTION	Peak (PK)
FREQUENCY RANGE	1GHz ~ 40GHz		Average (AV)

ANTENNA POLARITY & TEST DISTANCE: HORIZONTAL AT 3 M								
NO.	FREQ. (MHz)	EMISSION LEVEL (dBuV/m)	LIMIT (dBuV/m)	MARGIN (dB)	ANTENNA HEIGHT (m)	TABLE ANGLE (Degree)	RAW VALUE (dBuV)	CORRECTION FACTOR (dB/m)
1	*5745.00	124.0 PK			1.69 H	5	84.0	40.0
2	*5745.00	113.5 AV			1.69 H	5	73.5	40.0
3	11490.00	59.3 PK	74.0	-14.7	1.54 H	313	40.0	19.3
4	11490.00	46.3 AV	54.0	-7.7	1.54 H	313	27.0	19.3
ANTENNA POLARITY & TEST DISTANCE: VERTICAL AT 3 M								
NO.	FREQ. (MHz)	EMISSION LEVEL (dBuV/m)	LIMIT (dBuV/m)	MARGIN (dB)	ANTENNA HEIGHT (m)	TABLE ANGLE (Degree)	RAW VALUE (dBuV)	CORRECTION FACTOR (dB/m)
1	*5745.00	118.6 PK			1.87 V	352	78.6	40.0
2	*5745.00	108.2 AV			1.87 V	352	68.2	40.0
3	11490.00	60.5 PK	74.0	-13.5	1.57 V	175	41.2	19.3
4	11490.00	47.9 AV	54.0	-6.1	1.57 V	175	28.6	19.3

Remarks:

1. Emission Level(dBuV/m) = Raw Value(dBuV) + Correction Factor(dB/m)
2. Correction Factor(dB/m) = Antenna Factor(dB/m) + Cable Factor(dB) – Pre-Amplifier Factor(dB)
3. The other emission levels were very low against the limit.
4. Margin value = Emission Level – Limit value
5. " * ": Fundamental frequency.
6. " # ": The radiated frequency is out of the restricted band.

CHANNEL	TX Channel 157	DETECTOR FUNCTION	Peak (PK)
FREQUENCY RANGE	1GHz ~ 40GHz		Average (AV)

ANTENNA POLARITY & TEST DISTANCE: HORIZONTAL AT 3 M

NO.	FREQ. (MHz)	EMISSION LEVEL (dBuV/m)	LIMIT (dBuV/m)	MARGIN (dB)	ANTENNA HEIGHT (m)	TABLE ANGLE (Degree)	RAW VALUE (dBuV)	CORRECTION FACTOR (dB/m)
1	*5785.00	124.1 PK			1.72 H	0	84.0	40.1
2	*5785.00	113.6 AV			1.72 H	0	73.5	40.1
3	11570.00	60.8 PK	74.0	-13.2	1.64 H	87	41.6	19.2
4	11570.00	48.1 AV	54.0	-5.9	1.64 H	87	28.9	19.2

ANTENNA POLARITY & TEST DISTANCE: VERTICAL AT 3 M

NO.	FREQ. (MHz)	EMISSION LEVEL (dBuV/m)	LIMIT (dBuV/m)	MARGIN (dB)	ANTENNA HEIGHT (m)	TABLE ANGLE (Degree)	RAW VALUE (dBuV)	CORRECTION FACTOR (dB/m)
1	*5785.00	119.3 PK			1.88 V	333	79.2	40.1
2	*5785.00	108.7 AV			1.88 V	333	68.6	40.1
3	11570.00	62.7 PK	74.0	-11.3	1.38 V	175	43.5	19.2
4	11570.00	49.7 AV	54.0	-4.3	1.38 V	175	30.5	19.2

Remarks:

1. Emission Level(dBuV/m) = Raw Value(dBuV) + Correction Factor(dB/m)
2. Correction Factor(dB/m) = Antenna Factor(dB/m) + Cable Factor(dB) – Pre-Amplifier Factor(dB)
3. The other emission levels were very low against the limit.
4. Margin value = Emission Level – Limit value
5. " * " : Fundamental frequency.

CHANNEL	TX Channel 165	DETECTOR FUNCTION	Peak (PK)
FREQUENCY RANGE	1GHz ~ 40GHz		Average (AV)

ANTENNA POLARITY & TEST DISTANCE: HORIZONTAL AT 3 M								
NO.	FREQ. (MHz)	EMISSION LEVEL (dBuV/m)	LIMIT (dBuV/m)	MARGIN (dB)	ANTENNA HEIGHT (m)	TABLE ANGLE (Degree)	RAW VALUE (dBuV)	CORRECTION FACTOR (dB/m)
1	*5825.00	124.2 PK			1.78 H	0	84.1	40.1
2	*5825.00	114.1 AV			1.78 H	0	74.0	40.1
3	11650.00	59.6 PK	74.0	-14.4	1.64 H	91	40.3	19.3
4	11650.00	47.8 AV	54.0	-6.2	1.64 H	91	28.5	19.3
ANTENNA POLARITY & TEST DISTANCE: VERTICAL AT 3 M								
NO.	FREQ. (MHz)	EMISSION LEVEL (dBuV/m)	LIMIT (dBuV/m)	MARGIN (dB)	ANTENNA HEIGHT (m)	TABLE ANGLE (Degree)	RAW VALUE (dBuV)	CORRECTION FACTOR (dB/m)
1	*5825.00	120.2 PK			1.93 V	331	80.1	40.1
2	*5825.00	109.4 AV			1.93 V	331	69.3	40.1
3	11650.00	62.9 PK	74.0	-11.1	1.74 V	138	43.6	19.3
4	11650.00	50.8 AV	54.0	-3.2	1.74 V	138	31.5	19.3

Remarks:

1. Emission Level(dBuV/m) = Raw Value(dBuV) + Correction Factor(dB/m)
2. Correction Factor(dB/m) = Antenna Factor(dB/m) + Cable Factor(dB) – Pre-Amplifier Factor(dB)
3. The other emission levels were very low against the limit.
4. Margin value = Emission Level – Limit value
5. " * ": Fundamental frequency.
6. " # ": The radiated frequency is out of the restricted band.

802.11n (HT20)

CHANNEL	TX Channel 36	DETECTOR FUNCTION	Peak (PK) Average (AV)
FREQUENCY RANGE	1GHz ~ 40GHz		

ANTENNA POLARITY & TEST DISTANCE: HORIZONTAL AT 3 M

NO.	FREQ. (MHz)	EMISSION LEVEL (dBuV/m)	LIMIT (dBuV/m)	MARGIN (dB)	ANTENNA HEIGHT (m)	TABLE ANGLE (Degree)	RAW VALUE (dBuV)	CORRECTION FACTOR (dB/m)
1	5135.00	56.8 PK	74.0	-17.2	1.54 H	348	52.0	4.8
2	5135.00	45.2 AV	54.0	-8.8	1.54 H	348	40.4	4.8
3	*5180.00	110.1 PK			1.55 H	356	71.4	38.7
4	*5180.00	98.9 AV			1.55 H	356	60.2	38.7
5	#10360.00	59.0 PK	74.0	-15.0	1.39 H	251	41.4	17.6
6	#10360.00	46.2 AV	54.0	-7.8	1.39 H	251	28.6	17.6

ANTENNA POLARITY & TEST DISTANCE: VERTICAL AT 3 M

NO.	FREQ. (MHz)	EMISSION LEVEL (dBuV/m)	LIMIT (dBuV/m)	MARGIN (dB)	ANTENNA HEIGHT (m)	TABLE ANGLE (Degree)	RAW VALUE (dBuV)	CORRECTION FACTOR (dB/m)
1	5150.00	57.6 PK	74.0	-16.4	1.79 V	333	52.8	4.8
2	5150.00	47.5 AV	54.0	-6.5	1.79 V	333	42.7	4.8
3	*5180.00	106.9 PK			1.89 V	341	68.2	38.7
4	*5180.00	96.5 AV			1.89 V	341	57.8	38.7
5	#10360.00	59.2 PK	74.0	-14.8	1.71 V	198	41.6	17.6
6	#10360.00	46.4 AV	54.0	-7.6	1.71 V	198	28.8	17.6

Remarks:

1. Emission Level(dBuV/m) = Raw Value(dBuV) + Correction Factor(dB/m)
2. Correction Factor(dB/m) = Antenna Factor(dB/m) + Cable Factor(dB) – Pre-Amplifier Factor(dB)
3. The other emission levels were very low against the limit.
4. Margin value = Emission Level – Limit value
5. " * ": Fundamental frequency.
6. " # ": The radiated frequency is out of the restricted band.

CHANNEL	TX Channel 40	DETECTOR FUNCTION	Peak (PK)
FREQUENCY RANGE	1GHz ~ 40GHz		Average (AV)

ANTENNA POLARITY & TEST DISTANCE: HORIZONTAL AT 3 M								
NO.	FREQ. (MHz)	EMISSION LEVEL (dBuV/m)	LIMIT (dBuV/m)	MARGIN (dB)	ANTENNA HEIGHT (m)	TABLE ANGLE (Degree)	RAW VALUE (dBuV)	CORRECTION FACTOR (dB/m)
1	*5200.00	109.7 PK			1.67 H	1	71.0	38.7
2	*5200.00	98.6 AV			1.67 H	1	59.9	38.7
3	#10400.00	58.8 PK	74.0	-15.2	1.55 H	288	41.2	17.6
4	#10400.00	46.0 AV	54.0	-8.0	1.55 H	288	28.4	17.6
ANTENNA POLARITY & TEST DISTANCE: VERTICAL AT 3 M								
NO.	FREQ. (MHz)	EMISSION LEVEL (dBuV/m)	LIMIT (dBuV/m)	MARGIN (dB)	ANTENNA HEIGHT (m)	TABLE ANGLE (Degree)	RAW VALUE (dBuV)	CORRECTION FACTOR (dB/m)
1	*5200.00	107.4 PK			1.76 V	329	68.7	38.7
2	*5200.00	96.7 AV			1.76 V	329	58.0	38.7
3	#10400.00	59.2 PK	74.0	-14.8	1.66 V	202	41.6	17.6
4	#10400.00	46.2 AV	54.0	-7.8	1.66 V	202	28.6	17.6

Remarks:

1. Emission Level(dBuV/m) = Raw Value(dBuV) + Correction Factor(dB/m)
2. Correction Factor(dB/m) = Antenna Factor(dB/m) + Cable Factor(dB) – Pre-Amplifier Factor(dB)
3. The other emission levels were very low against the limit.
4. Margin value = Emission Level – Limit value
5. " * ": Fundamental frequency.
6. " # ": The radiated frequency is out of the restricted band.

CHANNEL	TX Channel 48	DETECTOR FUNCTION	Peak (PK)
FREQUENCY RANGE	1GHz ~ 40GHz		Average (AV)

ANTENNA POLARITY & TEST DISTANCE: HORIZONTAL AT 3 M								
NO.	FREQ. (MHz)	EMISSION LEVEL (dBuV/m)	LIMIT (dBuV/m)	MARGIN (dB)	ANTENNA HEIGHT (m)	TABLE ANGLE (Degree)	RAW VALUE (dBuV)	CORRECTION FACTOR (dB/m)
1	*5240.00	110.7 PK			1.63 H	359	71.8	38.9
2	*5240.00	99.5 AV			1.63 H	359	60.6	38.9
3	5350.00	57.7 PK	74.0	-16.3	1.61 H	1	52.2	5.5
4	5350.00	46.6 AV	54.0	-7.4	1.61 H	1	41.1	5.5
5	#10480.00	59.3 PK	74.0	-14.7	1.43 H	255	40.9	18.4
6	#10480.00	46.7 AV	54.0	-7.3	1.43 H	255	28.3	18.4

ANTENNA POLARITY & TEST DISTANCE: VERTICAL AT 3 M								
NO.	FREQ. (MHz)	EMISSION LEVEL (dBuV/m)	LIMIT (dBuV/m)	MARGIN (dB)	ANTENNA HEIGHT (m)	TABLE ANGLE (Degree)	RAW VALUE (dBuV)	CORRECTION FACTOR (dB/m)
1	*5240.00	106.5 PK			1.76 V	342	67.6	38.9
2	*5240.00	96.2 AV			1.76 V	342	57.3	38.9
3	5350.00	56.4 PK	74.0	-17.6	1.88 V	326	50.9	5.5
4	5350.00	45.1 AV	54.0	-8.9	1.88 V	326	39.6	5.5
5	#10480.00	59.6 PK	74.0	-14.4	1.74 V	211	41.2	18.4
6	#10480.00	46.6 AV	54.0	-7.4	1.74 V	211	28.2	18.4

Remarks:

1. Emission Level(dBuV/m) = Raw Value(dBuV) + Correction Factor(dB/m)
2. Correction Factor(dB/m) = Antenna Factor(dB/m) + Cable Factor(dB) – Pre-Amplifier Factor(dB)
3. The other emission levels were very low against the limit.
4. Margin value = Emission Level – Limit value
5. " * ": Fundamental frequency.
6. " # ": The radiated frequency is out of the restricted band.

CHANNEL	TX Channel 149	DETECTOR FUNCTION	Peak (PK)
FREQUENCY RANGE	1GHz ~ 40GHz		Average (AV)

ANTENNA POLARITY & TEST DISTANCE: HORIZONTAL AT 3 M								
NO.	FREQ. (MHz)	EMISSION LEVEL (dBuV/m)	LIMIT (dBuV/m)	MARGIN (dB)	ANTENNA HEIGHT (m)	TABLE ANGLE (Degree)	RAW VALUE (dBuV)	CORRECTION FACTOR (dB/m)
1	*5745.00	123.2 PK			1.78 H	358	83.2	40.0
2	*5745.00	112.7 AV			1.78 H	358	72.7	40.0
3	11490.00	59.0 PK	74.0	-15.0	1.66 H	226	39.7	19.3
4	11490.00	46.2 AV	54.0	-7.8	1.66 H	226	26.9	19.3
ANTENNA POLARITY & TEST DISTANCE: VERTICAL AT 3 M								
NO.	FREQ. (MHz)	EMISSION LEVEL (dBuV/m)	LIMIT (dBuV/m)	MARGIN (dB)	ANTENNA HEIGHT (m)	TABLE ANGLE (Degree)	RAW VALUE (dBuV)	CORRECTION FACTOR (dB/m)
1	*5745.00	119.6 PK			1.80 V	353	79.6	40.0
2	*5745.00	108.4 AV			1.80 V	353	68.4	40.0
3	11490.00	59.1 PK	74.0	-14.9	1.38 V	171	39.8	19.3
4	11490.00	47.2 AV	54.0	-6.8	1.38 V	171	27.9	19.3

Remarks:

1. Emission Level(dBuV/m) = Raw Value(dBuV) + Correction Factor(dB/m)
2. Correction Factor(dB/m) = Antenna Factor(dB/m) + Cable Factor(dB) – Pre-Amplifier Factor(dB)
3. The other emission levels were very low against the limit.
4. Margin value = Emission Level – Limit value
5. " * ": Fundamental frequency.
6. " # ": The radiated frequency is out of the restricted band.

CHANNEL	TX Channel 157	DETECTOR FUNCTION	Peak (PK)
FREQUENCY RANGE	1GHz ~ 40GHz		Average (AV)

ANTENNA POLARITY & TEST DISTANCE: HORIZONTAL AT 3 M

NO.	FREQ. (MHz)	EMISSION LEVEL (dBuV/m)	LIMIT (dBuV/m)	MARGIN (dB)	ANTENNA HEIGHT (m)	TABLE ANGLE (Degree)	RAW VALUE (dBuV)	CORRECTION FACTOR (dB/m)
1	*5785.00	123.2 PK			1.77 H	3	83.1	40.1
2	*5785.00	112.6 AV			1.77 H	3	72.5	40.1
3	11570.00	59.6 PK	74.0	-14.4	1.86 H	127	40.4	19.2
4	11570.00	47.2 AV	54.0	-6.8	1.86 H	127	28.0	19.2

ANTENNA POLARITY & TEST DISTANCE: VERTICAL AT 3 M

NO.	FREQ. (MHz)	EMISSION LEVEL (dBuV/m)	LIMIT (dBuV/m)	MARGIN (dB)	ANTENNA HEIGHT (m)	TABLE ANGLE (Degree)	RAW VALUE (dBuV)	CORRECTION FACTOR (dB/m)
1	*5785.00	119.8 PK			1.81 V	346	79.7	40.1
2	*5785.00	108.6 AV			1.81 V	346	68.5	40.1
3	11570.00	63.0 PK	74.0	-11.0	1.36 V	177	43.8	19.2
4	11570.00	48.9 AV	54.0	-5.1	1.36 V	177	29.7	19.2

Remarks:

1. Emission Level(dBuV/m) = Raw Value(dBuV) + Correction Factor(dB/m)
2. Correction Factor(dB/m) = Antenna Factor(dB/m) + Cable Factor(dB) – Pre-Amplifier Factor(dB)
3. The other emission levels were very low against the limit.
4. Margin value = Emission Level – Limit value
5. " * " : Fundamental frequency.

CHANNEL	TX Channel 165	DETECTOR FUNCTION	Peak (PK)
FREQUENCY RANGE	1GHz ~ 40GHz		Average (AV)

ANTENNA POLARITY & TEST DISTANCE: HORIZONTAL AT 3 M

NO.	FREQ. (MHz)	EMISSION LEVEL (dBuV/m)	LIMIT (dBuV/m)	MARGIN (dB)	ANTENNA HEIGHT (m)	TABLE ANGLE (Degree)	RAW VALUE (dBuV)	CORRECTION FACTOR (dB/m)
1	*5825.00	124.6 PK			1.70 H	2	84.5	40.1
2	*5825.00	113.9 AV			1.70 H	2	73.8	40.1
3	11650.00	59.5 PK	74.0	-14.5	1.73 H	320	40.2	19.3
4	11650.00	46.8 AV	54.0	-7.2	1.73 H	320	27.5	19.3

ANTENNA POLARITY & TEST DISTANCE: VERTICAL AT 3 M

NO.	FREQ. (MHz)	EMISSION LEVEL (dBuV/m)	LIMIT (dBuV/m)	MARGIN (dB)	ANTENNA HEIGHT (m)	TABLE ANGLE (Degree)	RAW VALUE (dBuV)	CORRECTION FACTOR (dB/m)
1	*5825.00	120.1 PK			1.81 V	341	80.0	40.1
2	*5825.00	109.6 AV			1.81 V	341	69.5	40.1
3	11650.00	63.0 PK	74.0	-11.0	1.32 V	178	43.7	19.3
4	11650.00	49.0 AV	54.0	-5.0	1.32 V	178	29.7	19.3

Remarks:

1. Emission Level(dBuV/m) = Raw Value(dBuV) + Correction Factor(dB/m)
2. Correction Factor(dB/m) = Antenna Factor(dB/m) + Cable Factor(dB) – Pre-Amplifier Factor(dB)
3. The other emission levels were very low against the limit.
4. Margin value = Emission Level – Limit value
5. " * ": Fundamental frequency.
6. " # ": The radiated frequency is out of the restricted band.

802.11n (HT40)

CHANNEL	TX Channel 38	DETECTOR FUNCTION	Peak (PK) Average (AV)
FREQUENCY RANGE	1GHz ~ 40GHz		

ANTENNA POLARITY & TEST DISTANCE: HORIZONTAL AT 3 M

NO.	FREQ. (MHz)	EMISSION LEVEL (dBuV/m)	LIMIT (dBuV/m)	MARGIN (dB)	ANTENNA HEIGHT (m)	TABLE ANGLE (Degree)	RAW VALUE (dBuV)	CORRECTION FACTOR (dB/m)
1	5150.00	58.3 PK	74.0	-15.7	1.52 H	348	53.5	4.8
2	5150.00	45.5 AV	54.0	-8.5	1.52 H	348	40.7	4.8
3	*5190.00	106.4 PK			1.67 H	352	67.7	38.7
4	*5190.00	97.0 AV			1.67 H	352	58.3	38.7
5	#10380.00	59.0 PK	74.0	-15.0	1.59 H	213	41.4	17.6
6	#10380.00	46.3 AV	54.0	-7.7	1.59 H	213	28.7	17.6

ANTENNA POLARITY & TEST DISTANCE: VERTICAL AT 3 M

NO.	FREQ. (MHz)	EMISSION LEVEL (dBuV/m)	LIMIT (dBuV/m)	MARGIN (dB)	ANTENNA HEIGHT (m)	TABLE ANGLE (Degree)	RAW VALUE (dBuV)	CORRECTION FACTOR (dB/m)
1	5150.00	58.2 PK	74.0	-15.8	1.82 V	332	53.4	4.8
2	5150.00	47.6 AV	54.0	-6.4	1.82 V	332	42.8	4.8
3	*5190.00	104.2 PK			1.74 V	338	65.5	38.7
4	*5190.00	94.5 AV			1.74 V	338	55.8	38.7
5	#10380.00	58.5 PK	74.0	-15.5	1.72 V	206	40.9	17.6
6	#10380.00	46.4 AV	54.0	-7.6	1.72 V	206	28.8	17.6

Remarks:

1. Emission Level(dBuV/m) = Raw Value(dBuV) + Correction Factor(dB/m)
2. Correction Factor(dB/m) = Antenna Factor(dB/m) + Cable Factor(dB) – Pre-Amplifier Factor(dB)
3. The other emission levels were very low against the limit.
4. Margin value = Emission Level – Limit value
5. " * ": Fundamental frequency.
6. " # ": The radiated frequency is out of the restricted band.

CHANNEL	TX Channel 46	DETECTOR FUNCTION	Peak (PK)
FREQUENCY RANGE	1GHz ~ 40GHz		Average (AV)

ANTENNA POLARITY & TEST DISTANCE: HORIZONTAL AT 3 M

NO.	FREQ. (MHz)	EMISSION LEVEL (dBuV/m)	LIMIT (dBuV/m)	MARGIN (dB)	ANTENNA HEIGHT (m)	TABLE ANGLE (Degree)	RAW VALUE (dBuV)	CORRECTION FACTOR (dB/m)
1	*5230.00	106.7 PK			1.72 H	357	67.8	38.9
2	*5230.00	97.4 AV			1.72 H	357	58.5	38.9
3	5350.00	58.0 PK	74.0	-16.0	1.85 H	0	52.5	5.5
4	5350.00	45.9 AV	54.0	-8.1	1.85 H	0	40.4	5.5
5	#10460.00	59.6 PK	74.0	-14.4	1.61 H	244	41.4	18.2
6	#10460.00	46.7 AV	54.0	-7.3	1.61 H	244	28.5	18.2

ANTENNA POLARITY & TEST DISTANCE: VERTICAL AT 3 M

NO.	FREQ. (MHz)	EMISSION LEVEL (dBuV/m)	LIMIT (dBuV/m)	MARGIN (dB)	ANTENNA HEIGHT (m)	TABLE ANGLE (Degree)	RAW VALUE (dBuV)	CORRECTION FACTOR (dB/m)
1	*5230.00	104.3 PK			1.79 V	355	65.4	38.9
2	*5230.00	94.8 AV			1.79 V	355	55.9	38.9
3	5350.00	57.0 PK	74.0	-17.0	1.67 V	332	51.5	5.5
4	5350.00	45.4 AV	54.0	-8.6	1.67 V	332	39.9	5.5
5	#10460.00	60.3 PK	74.0	-13.7	1.75 V	196	42.1	18.2
6	#10460.00	46.5 AV	54.0	-7.5	1.75 V	196	28.3	18.2

Remarks:

1. Emission Level(dBuV/m) = Raw Value(dBuV) + Correction Factor(dB/m)
2. Correction Factor(dB/m) = Antenna Factor(dB/m) + Cable Factor(dB) – Pre-Amplifier Factor(dB)
3. The other emission levels were very low against the limit.
4. Margin value = Emission Level – Limit value
5. " * ": Fundamental frequency.
6. " # ": The radiated frequency is out of the restricted band.

CHANNEL	TX Channel 151	DETECTOR FUNCTION	Peak (PK)
FREQUENCY RANGE	1GHz ~ 40GHz		Average (AV)

ANTENNA POLARITY & TEST DISTANCE: HORIZONTAL AT 3 M								
NO.	FREQ. (MHz)	EMISSION LEVEL (dBuV/m)	LIMIT (dBuV/m)	MARGIN (dB)	ANTENNA HEIGHT (m)	TABLE ANGLE (Degree)	RAW VALUE (dBuV)	CORRECTION FACTOR (dB/m)
1	*5755.00	120.2 PK			1.72 H	3	80.2	40.0
2	*5755.00	110.4 AV			1.72 H	3	70.4	40.0
3	11510.00	59.3 PK	74.0	-14.7	1.72 H	169	40.0	19.3
4	11510.00	46.4 AV	54.0	-7.6	1.72 H	169	27.1	19.3
ANTENNA POLARITY & TEST DISTANCE: VERTICAL AT 3 M								
NO.	FREQ. (MHz)	EMISSION LEVEL (dBuV/m)	LIMIT (dBuV/m)	MARGIN (dB)	ANTENNA HEIGHT (m)	TABLE ANGLE (Degree)	RAW VALUE (dBuV)	CORRECTION FACTOR (dB/m)
1	*5755.00	115.8 PK			1.90 V	0	75.8	40.0
2	*5755.00	106.4 AV			1.90 V	0	66.4	40.0
3	11510.00	58.9 PK	74.0	-15.1	1.38 V	165	39.6	19.3
4	11510.00	46.8 AV	54.0	-7.2	1.38 V	165	27.5	19.3

Remarks:

1. Emission Level(dBuV/m) = Raw Value(dBuV) + Correction Factor(dB/m)
2. Correction Factor(dB/m) = Antenna Factor(dB/m) + Cable Factor(dB) – Pre-Amplifier Factor(dB)
3. The other emission levels were very low against the limit.
4. Margin value = Emission Level – Limit value
5. " * ": Fundamental frequency.
6. " # ": The radiated frequency is out of the restricted band.

CHANNEL	TX Channel 159	DETECTOR FUNCTION	Peak (PK)
FREQUENCY RANGE	1GHz ~ 40GHz		Average (AV)

ANTENNA POLARITY & TEST DISTANCE: HORIZONTAL AT 3 M								
NO.	FREQ. (MHz)	EMISSION LEVEL (dBuV/m)	LIMIT (dBuV/m)	MARGIN (dB)	ANTENNA HEIGHT (m)	TABLE ANGLE (Degree)	RAW VALUE (dBuV)	CORRECTION FACTOR (dB/m)
1	*5795.00	120.5 PK			1.78 H	0	80.4	40.1
2	*5795.00	111.0 AV			1.78 H	0	70.9	40.1
3	11590.00	59.2 PK	74.0	-14.8	1.37 H	153	40.0	19.2
4	11590.00	46.6 AV	54.0	-7.4	1.37 H	153	27.4	19.2
ANTENNA POLARITY & TEST DISTANCE: VERTICAL AT 3 M								
NO.	FREQ. (MHz)	EMISSION LEVEL (dBuV/m)	LIMIT (dBuV/m)	MARGIN (dB)	ANTENNA HEIGHT (m)	TABLE ANGLE (Degree)	RAW VALUE (dBuV)	CORRECTION FACTOR (dB/m)
1	*5795.00	116.0 PK			1.91 V	359	75.9	40.1
2	*5795.00	106.7 AV			1.91 V	359	66.6	40.1
3	11590.00	61.6 PK	74.0	-12.4	1.42 V	173	42.4	19.2
4	11590.00	48.5 AV	54.0	-5.5	1.42 V	173	29.3	19.2

Remarks:

1. Emission Level(dBuV/m) = Raw Value(dBuV) + Correction Factor(dB/m)
2. Correction Factor(dB/m) = Antenna Factor(dB/m) + Cable Factor(dB) – Pre-Amplifier Factor(dB)
3. The other emission levels were very low against the limit.
4. Margin value = Emission Level – Limit value
5. " * ": Fundamental frequency.
6. " # ": The radiated frequency is out of the restricted band.

802.11ac (VHT80)

CHANNEL	TX Channel 42	DETECTOR FUNCTION	Peak (PK) Average (AV)
FREQUENCY RANGE	1GHz ~ 40GHz		

ANTENNA POLARITY & TEST DISTANCE: HORIZONTAL AT 3 M

NO.	FREQ. (MHz)	EMISSION LEVEL (dBuV/m)	LIMIT (dBuV/m)	MARGIN (dB)	ANTENNA HEIGHT (m)	TABLE ANGLE (Degree)	RAW VALUE (dBuV)	CORRECTION FACTOR (dB/m)
1	5150.00	59.2 PK	74.0	-14.8	1.57 H	357	54.4	4.8
2	5150.00	46.3 AV	54.0	-7.7	1.57 H	357	41.5	4.8
3	*5210.00	102.7 PK			1.63 H	353	64.0	38.7
4	*5210.00	93.0 AV			1.63 H	353	54.3	38.7
5	5350.00	57.4 PK	74.0	-16.6	1.76 H	353	51.9	5.5
6	5350.00	45.6 AV	54.0	-8.4	1.76 H	353	40.1	5.5
7	#10420.00	59.9 PK	74.0	-14.1	1.41 H	231	42.1	17.8
8	#10420.00	46.5 AV	54.0	-7.5	1.41 H	231	28.7	17.8

ANTENNA POLARITY & TEST DISTANCE: VERTICAL AT 3 M

NO.	FREQ. (MHz)	EMISSION LEVEL (dBuV/m)	LIMIT (dBuV/m)	MARGIN (dB)	ANTENNA HEIGHT (m)	TABLE ANGLE (Degree)	RAW VALUE (dBuV)	CORRECTION FACTOR (dB/m)
1	5150.00	57.0 PK	74.0	-17.0	1.74 V	334	52.2	4.8
2	5150.00	46.9 AV	54.0	-7.1	1.74 V	334	42.1	4.8
3	*5210.00	101.0 PK			1.70 V	339	62.3	38.7
4	*5210.00	90.4 AV			1.70 V	339	51.7	38.7
5	5350.00	57.6 PK	74.0	-16.4	1.80 V	338	52.1	5.5
6	5350.00	45.6 AV	54.0	-8.4	1.80 V	338	40.1	5.5
7	#10420.00	59.3 PK	74.0	-14.7	1.68 V	211	41.5	17.8
8	#10420.00	46.5 AV	54.0	-7.5	1.68 V	211	28.7	17.8

Remarks:

1. Emission Level(dBuV/m) = Raw Value(dBuV) + Correction Factor(dB/m)
2. Correction Factor(dB/m) = Antenna Factor(dB/m) + Cable Factor(dB) – Pre-Amplifier Factor(dB)
3. The other emission levels were very low against the limit.
4. Margin value = Emission Level – Limit value
5. " * ": Fundamental frequency.
6. " # ": The radiated frequency is out of the restricted band.

CHANNEL	TX Channel 155	DETECTOR FUNCTION	Peak (PK)
FREQUENCY RANGE	1GHz ~ 40GHz		Average (AV)

ANTENNA POLARITY & TEST DISTANCE: HORIZONTAL AT 3 M								
NO.	FREQ. (MHz)	EMISSION LEVEL (dBuV/m)	LIMIT (dBuV/m)	MARGIN (dB)	ANTENNA HEIGHT (m)	TABLE ANGLE (Degree)	RAW VALUE (dBuV)	CORRECTION FACTOR (dB/m)
1	*5775.00	114.0 PK			1.74 H	1	74.0	40.0
2	*5775.00	104.2 AV			1.74 H	1	64.2	40.0
3	11550.00	58.6 PK	74.0	-15.4	1.41 H	167	39.4	19.2
4	11550.00	46.8 AV	54.0	-7.2	1.41 H	167	27.6	19.2
ANTENNA POLARITY & TEST DISTANCE: VERTICAL AT 3 M								
NO.	FREQ. (MHz)	EMISSION LEVEL (dBuV/m)	LIMIT (dBuV/m)	MARGIN (dB)	ANTENNA HEIGHT (m)	TABLE ANGLE (Degree)	RAW VALUE (dBuV)	CORRECTION FACTOR (dB/m)
1	*5775.00	119.9 PK			1.85 V	353	79.9	40.0
2	*5775.00	109.8 AV			1.85 V	353	69.8	40.0
3	11550.00	59.7 PK	74.0	-14.3	1.50 V	158	40.5	19.2
4	11550.00	47.0 AV	54.0	-7.0	1.50 V	158	27.8	19.2

Remarks:

1. Emission Level(dBuV/m) = Raw Value(dBuV) + Correction Factor(dB/m)
2. Correction Factor(dB/m) = Antenna Factor(dB/m) + Cable Factor(dB) – Pre-Amplifier Factor(dB)
3. The other emission levels were very low against the limit.
4. Margin value = Emission Level – Limit value
5. " * ": Fundamental frequency.
6. " # ": The radiated frequency is out of the restricted band.

Below 1GHz Worst-Case Data:

802.11a

CHANNEL	TX Channel 149	DETECTOR FUNCTION	Quasi-Peak (QP)
FREQUENCY RANGE	9kHz ~ 1GHz		

ANTENNA POLARITY & TEST DISTANCE: HORIZONTAL AT 3 M								
NO.	FREQ. (MHz)	EMISSION LEVEL (dBuV/m)	LIMIT (dBuV/m)	MARGIN (dB)	ANTENNA HEIGHT (m)	TABLE ANGLE (Degree)	RAW VALUE (dBuV)	CORRECTION FACTOR (dB/m)
1	35.73	32.2 QP	40.0	-7.8	1.50 H	72	47.8	-15.6
2	109.62	30.0 QP	43.5	-13.5	1.50 H	86	47.4	-17.4
3	185.44	30.8 QP	43.5	-12.7	1.50 H	85	46.6	-15.8
4	249.60	37.2 QP	46.0	-8.8	1.00 H	100	51.2	-14.0
5	374.04	38.5 QP	46.0	-7.5	1.00 H	229	49.0	-10.5
6	875.67	41.0 QP	46.0	-5.0	1.50 H	40	41.1	-0.1
ANTENNA POLARITY & TEST DISTANCE: VERTICAL AT 3 M								
NO.	FREQ. (MHz)	EMISSION LEVEL (dBuV/m)	LIMIT (dBuV/m)	MARGIN (dB)	ANTENNA HEIGHT (m)	TABLE ANGLE (Degree)	RAW VALUE (dBuV)	CORRECTION FACTOR (dB/m)
1	35.73	38.3 QP	40.0	-1.7	1.50 V	16	53.9	-15.6
2	55.18	37.6 QP	40.0	-2.4	1.00 V	319	52.0	-14.4
3	201.00	28.8 QP	43.5	-14.7	1.00 V	124	45.3	-16.5
4	249.60	33.7 QP	46.0	-12.3	1.00 V	85	47.7	-14.0
5	374.04	40.6 QP	46.0	-5.4	1.50 V	177	51.1	-10.5
6	875.67	41.0 QP	46.0	-5.0	1.00 V	107	41.1	-0.1

Remarks:

1. Emission Level(dBuV/m) = Raw Value(dBuV) + Correction Factor(dB/m)
2. Correction Factor(dB/m) = Antenna Factor(dB/m) + Cable Factor(dB) – Pre-Amplifier Factor(dB)
3. The other emission levels were very low against the limit.
4. Margin value = Emission Level – Limit value

Test Mode C

Above 1GHz worst-Case Data:

802.11a

CHANNEL	TX Channel 36	DETECTOR FUNCTION	Peak (PK)
FREQUENCY RANGE	1GHz ~ 40GHz		Average (AV)

ANTENNA POLARITY & TEST DISTANCE: HORIZONTAL AT 3 M

NO.	FREQ. (MHz)	EMISSION LEVEL (dBuV/m)	LIMIT (dBuV/m)	MARGIN (dB)	ANTENNA HEIGHT (m)	TABLE ANGLE (Degree)	RAW VALUE (dBuV)	CORRECTION FACTOR (dB/m)
1	4822.00	54.7 PK	74.0	-19.3	1.70 H	151	50.9	3.8
2	4822.00	43.7 AV	54.0	-10.3	1.70 H	151	39.9	3.8
3	*5180.00	110.4 PK			1.42 H	329	71.7	38.7
4	*5180.00	99.8 AV			1.42 H	329	61.1	38.7
5	#10360.00	58.3 PK	74.0	-15.7	1.28 H	217	40.7	17.6
6	#10360.00	46.0 AV	54.0	-8.0	1.28 H	217	28.4	17.6

ANTENNA POLARITY & TEST DISTANCE: VERTICAL AT 3 M

NO.	FREQ. (MHz)	EMISSION LEVEL (dBuV/m)	LIMIT (dBuV/m)	MARGIN (dB)	ANTENNA HEIGHT (m)	TABLE ANGLE (Degree)	RAW VALUE (dBuV)	CORRECTION FACTOR (dB/m)
1	4822.00	56.9 PK	74.0	-17.1	1.19 V	346	53.1	3.8
2	4822.00	46.8 AV	54.0	-7.2	1.19 V	346	43.0	3.8
3	*5180.00	112.4 PK			1.29 V	353	73.7	38.7
4	*5180.00	101.4 AV			1.29 V	353	62.7	38.7
5	#10360.00	58.7 PK	74.0	-15.3	1.85 V	80	41.1	17.6
6	#10360.00	46.0 AV	54.0	-8.0	1.85 V	80	28.4	17.6

Remarks:

1. Emission Level(dBuV/m) = Raw Value(dBuV) + Correction Factor(dB/m)
2. Correction Factor(dB/m) = Antenna Factor(dB/m) + Cable Factor(dB) – Pre-Amplifier Factor(dB)
3. The other emission levels were very low against the limit.
4. Margin value = Emission Level – Limit value
5. " * ": Fundamental frequency.
6. " # ": The radiated frequency is out of the restricted band.

CHANNEL	TX Channel 40	DETECTOR FUNCTION	Peak (PK)
FREQUENCY RANGE	1GHz ~ 40GHz		Average (AV)

ANTENNA POLARITY & TEST DISTANCE: HORIZONTAL AT 3 M								
NO.	FREQ. (MHz)	EMISSION LEVEL (dBuV/m)	LIMIT (dBuV/m)	MARGIN (dB)	ANTENNA HEIGHT (m)	TABLE ANGLE (Degree)	RAW VALUE (dBuV)	CORRECTION FACTOR (dB/m)
1	*5200.00	110.0 PK			1.50 H	328	71.3	38.7
2	*5200.00	99.4 AV			1.50 H	328	60.7	38.7
3	#10400.00	58.4 PK	74.0	-15.6	1.69 H	221	40.8	17.6
4	#10400.00	46.2 AV	54.0	-7.8	1.69 H	221	28.6	17.6
ANTENNA POLARITY & TEST DISTANCE: VERTICAL AT 3 M								
NO.	FREQ. (MHz)	EMISSION LEVEL (dBuV/m)	LIMIT (dBuV/m)	MARGIN (dB)	ANTENNA HEIGHT (m)	TABLE ANGLE (Degree)	RAW VALUE (dBuV)	CORRECTION FACTOR (dB/m)
1	*5200.00	113.1 PK			1.35 V	353	74.4	38.7
2	*5200.00	101.8 AV			1.35 V	353	63.1	38.7
3	#10400.00	58.4 PK	74.0	-15.6	1.43 V	221	40.8	17.6
4	#10400.00	46.1 AV	54.0	-7.9	1.43 V	221	28.5	17.6

Remarks:

1. Emission Level(dBuV/m) = Raw Value(dBuV) + Correction Factor(dB/m)
2. Correction Factor(dB/m) = Antenna Factor(dB/m) + Cable Factor(dB) – Pre-Amplifier Factor(dB)
3. The other emission levels were very low against the limit.
4. Margin value = Emission Level – Limit value
5. " * ": Fundamental frequency.
6. " # ": The radiated frequency is out of the restricted band.

CHANNEL	TX Channel 48	DETECTOR FUNCTION	Peak (PK)
FREQUENCY RANGE	1GHz ~ 40GHz		Average (AV)

ANTENNA POLARITY & TEST DISTANCE: HORIZONTAL AT 3 M

NO.	FREQ. (MHz)	EMISSION LEVEL (dBuV/m)	LIMIT (dBuV/m)	MARGIN (dB)	ANTENNA HEIGHT (m)	TABLE ANGLE (Degree)	RAW VALUE (dBuV)	CORRECTION FACTOR (dB/m)
1	*5240.00	111.4 PK			1.95 H	334	72.5	38.9
2	*5240.00	100.4 AV			1.95 H	334	61.5	38.9
3	5350.00	57.4 PK	74.0	-16.6	1.59 H	327	51.9	5.5
4	5350.00	45.5 AV	54.0	-8.5	1.59 H	327	40.0	5.5
5	#10480.00	58.8 PK	74.0	-15.2	1.71 H	36	40.4	18.4
6	#10480.00	46.5 AV	54.0	-7.5	1.71 H	36	28.1	18.4

ANTENNA POLARITY & TEST DISTANCE: VERTICAL AT 3 M

NO.	FREQ. (MHz)	EMISSION LEVEL (dBuV/m)	LIMIT (dBuV/m)	MARGIN (dB)	ANTENNA HEIGHT (m)	TABLE ANGLE (Degree)	RAW VALUE (dBuV)	CORRECTION FACTOR (dB/m)
1	*5240.00	114.2 PK			1.42 V	352	75.3	38.9
2	*5240.00	102.9 AV			1.42 V	352	64.0	38.9
3	5350.00	57.6 PK	74.0	-16.4	1.35 V	2	52.1	5.5
4	5350.00	45.8 AV	54.0	-8.2	1.35 V	2	40.3	5.5
5	#10480.00	59.1 PK	74.0	-14.9	1.26 V	261	40.7	18.4
6	#10480.00	46.4 AV	54.0	-7.6	1.26 V	261	28.0	18.4

Remarks:

1. Emission Level(dBuV/m) = Raw Value(dBuV) + Correction Factor(dB/m)
2. Correction Factor(dB/m) = Antenna Factor(dB/m) + Cable Factor(dB) – Pre-Amplifier Factor(dB)
3. The other emission levels were very low against the limit.
4. Margin value = Emission Level – Limit value
5. " * ": Fundamental frequency.
6. " # ": The radiated frequency is out of the restricted band.

CHANNEL	TX Channel 149	DETECTOR FUNCTION	Peak (PK)
FREQUENCY RANGE	1GHz ~ 40GHz		Average (AV)

ANTENNA POLARITY & TEST DISTANCE: HORIZONTAL AT 3 M

NO.	FREQ. (MHz)	EMISSION LEVEL (dBuV/m)	LIMIT (dBuV/m)	MARGIN (dB)	ANTENNA HEIGHT (m)	TABLE ANGLE (Degree)	RAW VALUE (dBuV)	CORRECTION FACTOR (dB/m)
1	*5745.00	116.9 PK			1.66 H	351	76.9	40.0
2	*5745.00	107.3 AV			1.66 H	351	67.3	40.0
3	11490.00	60.4 PK	74.0	-13.6	1.82 H	143	41.1	19.3
4	11490.00	47.7 AV	54.0	-6.3	1.82 H	143	28.4	19.3

ANTENNA POLARITY & TEST DISTANCE: VERTICAL AT 3 M

NO.	FREQ. (MHz)	EMISSION LEVEL (dBuV/m)	LIMIT (dBuV/m)	MARGIN (dB)	ANTENNA HEIGHT (m)	TABLE ANGLE (Degree)	RAW VALUE (dBuV)	CORRECTION FACTOR (dB/m)
1	*5745.00	119.5 PK			1.53 V	343	79.5	40.0
2	*5745.00	108.9 AV			1.53 V	343	68.9	40.0
3	11490.00	63.1 PK	74.0	-10.9	2.22 V	157	43.8	19.3
4	11490.00	50.8 AV	54.0	-3.2	2.22 V	157	31.5	19.3

Remarks:

1. Emission Level(dBuV/m) = Raw Value(dBuV) + Correction Factor(dB/m)
2. Correction Factor(dB/m) = Antenna Factor(dB/m) + Cable Factor(dB) – Pre-Amplifier Factor(dB)
3. The other emission levels were very low against the limit.
4. Margin value = Emission Level – Limit value
5. " * ": Fundamental frequency.
6. " # ": The radiated frequency is out of the restricted band.

CHANNEL	TX Channel 157	DETECTOR FUNCTION	Peak (PK)
FREQUENCY RANGE	1GHz ~ 40GHz		Average (AV)

ANTENNA POLARITY & TEST DISTANCE: HORIZONTAL AT 3 M

NO.	FREQ. (MHz)	EMISSION LEVEL (dBuV/m)	LIMIT (dBuV/m)	MARGIN (dB)	ANTENNA HEIGHT (m)	TABLE ANGLE (Degree)	RAW VALUE (dBuV)	CORRECTION FACTOR (dB/m)
1	*5785.00	117.2 PK			1.67 H	347	77.1	40.1
2	*5785.00	106.9 AV			1.67 H	347	66.8	40.1
3	11570.00	62.5 PK	74.0	-11.5	2.17 H	139	43.3	19.2
4	11570.00	49.6 AV	54.0	-4.4	2.17 H	139	30.4	19.2

ANTENNA POLARITY & TEST DISTANCE: VERTICAL AT 3 M

NO.	FREQ. (MHz)	EMISSION LEVEL (dBuV/m)	LIMIT (dBuV/m)	MARGIN (dB)	ANTENNA HEIGHT (m)	TABLE ANGLE (Degree)	RAW VALUE (dBuV)	CORRECTION FACTOR (dB/m)
1	*5785.00	118.8 PK			1.89 V	343	78.7	40.1
2	*5785.00	107.7 AV			1.89 V	343	67.6	40.1
3	11570.00	62.6 PK	74.0	-11.4	2.50 V	158	43.4	19.2
4	11570.00	52.5 AV	54.0	-1.5	2.50 V	158	33.3	19.2

Remarks:

1. Emission Level(dBuV/m) = Raw Value(dBuV) + Correction Factor(dB/m)
2. Correction Factor(dB/m) = Antenna Factor(dB/m) + Cable Factor(dB) – Pre-Amplifier Factor(dB)
3. The other emission levels were very low against the limit.
4. Margin value = Emission Level – Limit value
5. " * ": Fundamental frequency.

CHANNEL	TX Channel 165	DETECTOR FUNCTION	Peak (PK)
FREQUENCY RANGE	1GHz ~ 40GHz		Average (AV)

ANTENNA POLARITY & TEST DISTANCE: HORIZONTAL AT 3 M								
NO.	FREQ. (MHz)	EMISSION LEVEL (dBuV/m)	LIMIT (dBuV/m)	MARGIN (dB)	ANTENNA HEIGHT (m)	TABLE ANGLE (Degree)	RAW VALUE (dBuV)	CORRECTION FACTOR (dB/m)
1	*5825.00	117.5 PK			2.08 H	345	77.4	40.1
2	*5825.00	107.3 AV			2.08 H	345	67.2	40.1
3	11650.00	62.0 PK	74.0	-12.0	2.24 H	139	42.7	19.3
4	11650.00	49.6 AV	54.0	-4.4	2.24 H	139	30.3	19.3
ANTENNA POLARITY & TEST DISTANCE: VERTICAL AT 3 M								
NO.	FREQ. (MHz)	EMISSION LEVEL (dBuV/m)	LIMIT (dBuV/m)	MARGIN (dB)	ANTENNA HEIGHT (m)	TABLE ANGLE (Degree)	RAW VALUE (dBuV)	CORRECTION FACTOR (dB/m)
1	*5825.00	119.2 PK			2.01 V	343	79.1	40.1
2	*5825.00	108.0 AV			2.01 V	343	67.9	40.1
3	11650.00	64.3 PK	74.0	-9.7	2.24 V	152	45.0	19.3
4	11650.00	51.6 AV	54.0	-2.4	2.24 V	152	32.3	19.3

Remarks:

1. Emission Level(dBuV/m) = Raw Value(dBuV) + Correction Factor(dB/m)
2. Correction Factor(dB/m) = Antenna Factor(dB/m) + Cable Factor(dB) – Pre-Amplifier Factor(dB)
3. The other emission levels were very low against the limit.
4. Margin value = Emission Level – Limit value
5. " * ": Fundamental frequency.
6. " # ": The radiated frequency is out of the restricted band.

802.11n (HT20)

CHANNEL	TX Channel 36	DETECTOR FUNCTION	Peak (PK) Average (AV)
FREQUENCY RANGE	1GHz ~ 40GHz		

ANTENNA POLARITY & TEST DISTANCE: HORIZONTAL AT 3 M

NO.	FREQ. (MHz)	EMISSION LEVEL (dBuV/m)	LIMIT (dBuV/m)	MARGIN (dB)	ANTENNA HEIGHT (m)	TABLE ANGLE (Degree)	RAW VALUE (dBuV)	CORRECTION FACTOR (dB/m)
1	4822.00	54.5 PK	74.0	-19.5	1.32 H	141	50.7	3.8
2	4822.00	43.6 AV	54.0	-10.4	1.32 H	141	39.8	3.8
3	*5180.00	111.2 PK			1.78 H	336	72.5	38.7
4	*5180.00	100.5 AV			1.78 H	336	61.8	38.7
5	#10360.00	58.5 PK	74.0	-15.5	1.32 H	88	40.9	17.6
6	#10360.00	45.7 AV	54.0	-8.3	1.32 H	88	28.1	17.6

ANTENNA POLARITY & TEST DISTANCE: VERTICAL AT 3 M

NO.	FREQ. (MHz)	EMISSION LEVEL (dBuV/m)	LIMIT (dBuV/m)	MARGIN (dB)	ANTENNA HEIGHT (m)	TABLE ANGLE (Degree)	RAW VALUE (dBuV)	CORRECTION FACTOR (dB/m)
1	4822.00	56.5 PK	74.0	-17.5	1.52 V	348	52.7	3.8
2	4822.00	46.7 AV	54.0	-7.3	1.52 V	348	42.9	3.8
3	*5180.00	111.4 PK			1.07 V	341	72.7	38.7
4	*5180.00	101.1 AV			1.07 V	341	62.4	38.7
5	#10360.00	58.3 PK	74.0	-15.7	1.27 V	238	40.7	17.6
6	#10360.00	45.8 AV	54.0	-8.2	1.27 V	238	28.2	17.6

Remarks:

1. Emission Level(dBuV/m) = Raw Value(dBuV) + Correction Factor(dB/m)
2. Correction Factor(dB/m) = Antenna Factor(dB/m) + Cable Factor(dB) – Pre-Amplifier Factor(dB)
3. The other emission levels were very low against the limit.
4. Margin value = Emission Level – Limit value
5. " * ": Fundamental frequency.
6. " # ": The radiated frequency is out of the restricted band.

CHANNEL	TX Channel 40	DETECTOR FUNCTION	Peak (PK)
FREQUENCY RANGE	1GHz ~ 40GHz		Average (AV)

ANTENNA POLARITY & TEST DISTANCE: HORIZONTAL AT 3 M								
NO.	FREQ. (MHz)	EMISSION LEVEL (dBuV/m)	LIMIT (dBuV/m)	MARGIN (dB)	ANTENNA HEIGHT (m)	TABLE ANGLE (Degree)	RAW VALUE (dBuV)	CORRECTION FACTOR (dB/m)
1	*5200.00	110.0 PK			1.42 H	337	71.3	38.7
2	*5200.00	99.3 AV			1.42 H	337	60.6	38.7
3	#10400.00	58.9 PK	74.0	-15.1	1.56 H	238	41.3	17.6
4	#10400.00	45.9 AV	54.0	-8.1	1.56 H	238	28.3	17.6
ANTENNA POLARITY & TEST DISTANCE: VERTICAL AT 3 M								
NO.	FREQ. (MHz)	EMISSION LEVEL (dBuV/m)	LIMIT (dBuV/m)	MARGIN (dB)	ANTENNA HEIGHT (m)	TABLE ANGLE (Degree)	RAW VALUE (dBuV)	CORRECTION FACTOR (dB/m)
1	*5200.00	111.9 PK			1.36 V	352	73.2	38.7
2	*5200.00	101.2 AV			1.36 V	352	62.5	38.7
3	#10400.00	58.6 PK	74.0	-15.4	1.29 V	236	41.0	17.6
4	#10400.00	46.0 AV	54.0	-8.0	1.29 V	236	28.4	17.6

Remarks:

1. Emission Level(dBuV/m) = Raw Value(dBuV) + Correction Factor(dB/m)
2. Correction Factor(dB/m) = Antenna Factor(dB/m) + Cable Factor(dB) – Pre-Amplifier Factor(dB)
3. The other emission levels were very low against the limit.
4. Margin value = Emission Level – Limit value
5. " * ": Fundamental frequency.
6. " # ": The radiated frequency is out of the restricted band.

CHANNEL	TX Channel 48	DETECTOR FUNCTION	Peak (PK)
FREQUENCY RANGE	1GHz ~ 40GHz		Average (AV)

ANTENNA POLARITY & TEST DISTANCE: HORIZONTAL AT 3 M								
NO.	FREQ. (MHz)	EMISSION LEVEL (dBuV/m)	LIMIT (dBuV/m)	MARGIN (dB)	ANTENNA HEIGHT (m)	TABLE ANGLE (Degree)	RAW VALUE (dBuV)	CORRECTION FACTOR (dB/m)
1	*5240.00	111.5 PK			1.24 H	341	72.6	38.9
2	*5240.00	100.4 AV			1.24 H	341	61.5	38.9
3	5350.00	56.7 PK	74.0	-17.3	1.38 H	316	51.2	5.5
4	5350.00	44.8 AV	54.0	-9.2	1.38 H	316	39.3	5.5
5	#10480.00	58.8 PK	74.0	-15.2	1.61 H	229	40.4	18.4
6	#10480.00	46.1 AV	54.0	-7.9	1.61 H	229	27.7	18.4
ANTENNA POLARITY & TEST DISTANCE: VERTICAL AT 3 M								
NO.	FREQ. (MHz)	EMISSION LEVEL (dBuV/m)	LIMIT (dBuV/m)	MARGIN (dB)	ANTENNA HEIGHT (m)	TABLE ANGLE (Degree)	RAW VALUE (dBuV)	CORRECTION FACTOR (dB/m)
1	*5240.00	114.0 PK			1.21 V	334	75.1	38.9
2	*5240.00	102.9 AV			1.21 V	334	64.0	38.9
3	5350.00	57.3 PK	74.0	-16.7	1.35 V	352	51.8	5.5
4	5350.00	45.8 AV	54.0	-8.2	1.35 V	352	40.3	5.5
5	#10480.00	59.1 PK	74.0	-14.9	1.84 V	186	40.7	18.4
6	#10480.00	46.3 AV	54.0	-7.7	1.84 V	186	27.9	18.4

Remarks:

1. Emission Level(dBuV/m) = Raw Value(dBuV) + Correction Factor(dB/m)
2. Correction Factor(dB/m) = Antenna Factor(dB/m) + Cable Factor(dB) – Pre-Amplifier Factor(dB)
3. The other emission levels were very low against the limit.
4. Margin value = Emission Level – Limit value
5. " * ": Fundamental frequency.
6. " # ": The radiated frequency is out of the restricted band.

CHANNEL	TX Channel 149	DETECTOR FUNCTION	Peak (PK)
FREQUENCY RANGE	1GHz ~ 40GHz		Average (AV)

ANTENNA POLARITY & TEST DISTANCE: HORIZONTAL AT 3 M								
NO.	FREQ. (MHz)	EMISSION LEVEL (dBuV/m)	LIMIT (dBuV/m)	MARGIN (dB)	ANTENNA HEIGHT (m)	TABLE ANGLE (Degree)	RAW VALUE (dBuV)	CORRECTION FACTOR (dB/m)
1	*5745.00	118.0 PK			2.27 H	349	78.0	40.0
2	*5745.00	107.3 AV			2.27 H	349	67.3	40.0
3	11490.00	60.3 PK	74.0	-13.7	1.77 H	135	41.0	19.3
4	11490.00	47.3 AV	54.0	-6.7	1.77 H	135	28.0	19.3
ANTENNA POLARITY & TEST DISTANCE: VERTICAL AT 3 M								
NO.	FREQ. (MHz)	EMISSION LEVEL (dBuV/m)	LIMIT (dBuV/m)	MARGIN (dB)	ANTENNA HEIGHT (m)	TABLE ANGLE (Degree)	RAW VALUE (dBuV)	CORRECTION FACTOR (dB/m)
1	*5745.00	119.5 PK			2.05 V	343	79.5	40.0
2	*5745.00	108.6 AV			2.05 V	343	68.6	40.0
3	11490.00	61.5 PK	74.0	-12.5	2.08 V	157	42.2	19.3
4	11490.00	49.0 AV	54.0	-5.0	2.08 V	157	29.7	19.3

Remarks:

1. Emission Level(dBuV/m) = Raw Value(dBuV) + Correction Factor(dB/m)
2. Correction Factor(dB/m) = Antenna Factor(dB/m) + Cable Factor(dB) – Pre-Amplifier Factor(dB)
3. The other emission levels were very low against the limit.
4. Margin value = Emission Level – Limit value
5. " * ": Fundamental frequency.
6. " # ": The radiated frequency is out of the restricted band.

CHANNEL	TX Channel 157	DETECTOR FUNCTION	Peak (PK)
FREQUENCY RANGE	1GHz ~ 40GHz		Average (AV)

ANTENNA POLARITY & TEST DISTANCE: HORIZONTAL AT 3 M

NO.	FREQ. (MHz)	EMISSION LEVEL (dBuV/m)	LIMIT (dBuV/m)	MARGIN (dB)	ANTENNA HEIGHT (m)	TABLE ANGLE (Degree)	RAW VALUE (dBuV)	CORRECTION FACTOR (dB/m)
1	*5785.00	116.4 PK			2.24 H	351	76.3	40.1
2	*5785.00	106.3 AV			2.24 H	351	66.2	40.1
3	11570.00	62.1 PK	74.0	-11.9	1.94 H	144	42.9	19.2
4	11570.00	49.1 AV	54.0	-4.9	1.94 H	144	29.9	19.2

ANTENNA POLARITY & TEST DISTANCE: VERTICAL AT 3 M

NO.	FREQ. (MHz)	EMISSION LEVEL (dBuV/m)	LIMIT (dBuV/m)	MARGIN (dB)	ANTENNA HEIGHT (m)	TABLE ANGLE (Degree)	RAW VALUE (dBuV)	CORRECTION FACTOR (dB/m)
1	*5785.00	118.2 PK			1.83 V	343	78.1	40.1
2	*5785.00	107.7 AV			1.83 V	343	67.6	40.1
3	11570.00	65.4 PK	74.0	-8.6	1.93 V	159	46.2	19.2
4	11570.00	51.4 AV	54.0	-2.6	1.93 V	159	32.2	19.2

Remarks:

1. Emission Level(dBuV/m) = Raw Value(dBuV) + Correction Factor(dB/m)
2. Correction Factor(dB/m) = Antenna Factor(dB/m) + Cable Factor(dB) – Pre-Amplifier Factor(dB)
3. The other emission levels were very low against the limit.
4. Margin value = Emission Level – Limit value
5. " * ": Fundamental frequency.

CHANNEL	TX Channel 165	DETECTOR FUNCTION	Peak (PK)
FREQUENCY RANGE	1GHz ~ 40GHz		Average (AV)

ANTENNA POLARITY & TEST DISTANCE: HORIZONTAL AT 3 M								
NO.	FREQ. (MHz)	EMISSION LEVEL (dBuV/m)	LIMIT (dBuV/m)	MARGIN (dB)	ANTENNA HEIGHT (m)	TABLE ANGLE (Degree)	RAW VALUE (dBuV)	CORRECTION FACTOR (dB/m)
1	*5825.00	117.3 PK			1.95 H	350	77.2	40.1
2	*5825.00	106.7 AV			1.95 H	350	66.6	40.1
3	11650.00	60.2 PK	74.0	-13.8	1.99 H	111	40.9	19.3
4	11650.00	48.5 AV	54.0	-5.5	1.99 H	111	29.2	19.3
ANTENNA POLARITY & TEST DISTANCE: VERTICAL AT 3 M								
NO.	FREQ. (MHz)	EMISSION LEVEL (dBuV/m)	LIMIT (dBuV/m)	MARGIN (dB)	ANTENNA HEIGHT (m)	TABLE ANGLE (Degree)	RAW VALUE (dBuV)	CORRECTION FACTOR (dB/m)
1	*5825.00	118.7 PK			1.63 V	344	78.6	40.1
2	*5825.00	107.5 AV			1.63 V	344	67.4	40.1
3	11650.00	63.8 PK	74.0	-10.2	1.90 V	156	44.5	19.3
4	11650.00	50.7 AV	54.0	-3.3	1.90 V	156	31.4	19.3

Remarks:

1. Emission Level(dBuV/m) = Raw Value(dBuV) + Correction Factor(dB/m)
2. Correction Factor(dB/m) = Antenna Factor(dB/m) + Cable Factor(dB) – Pre-Amplifier Factor(dB)
3. The other emission levels were very low against the limit.
4. Margin value = Emission Level – Limit value
5. " * ": Fundamental frequency.
6. " # ": The radiated frequency is out of the restricted band.

802.11n (HT40)

CHANNEL	TX Channel 38	DETECTOR FUNCTION	Peak (PK) Average (AV)
FREQUENCY RANGE	1GHz ~ 40GHz		

ANTENNA POLARITY & TEST DISTANCE: HORIZONTAL AT 3 M

NO.	FREQ. (MHz)	EMISSION LEVEL (dBuV/m)	LIMIT (dBuV/m)	MARGIN (dB)	ANTENNA HEIGHT (m)	TABLE ANGLE (Degree)	RAW VALUE (dBuV)	CORRECTION FACTOR (dB/m)
1	5150.00	64.2 PK	74.0	-9.8	1.84 H	331	59.4	4.8
2	5150.00	49.0 AV	54.0	-5.0	1.84 H	331	44.2	4.8
3	*5190.00	107.0 PK			2.08 H	338	68.3	38.7
4	*5190.00	97.2 AV			2.08 H	338	58.5	38.7
5	#10380.00	58.7 PK	74.0	-15.3	1.71 H	261	41.1	17.6
6	#10380.00	46.0 AV	54.0	-8.0	1.71 H	261	28.4	17.6

ANTENNA POLARITY & TEST DISTANCE: VERTICAL AT 3 M

NO.	FREQ. (MHz)	EMISSION LEVEL (dBuV/m)	LIMIT (dBuV/m)	MARGIN (dB)	ANTENNA HEIGHT (m)	TABLE ANGLE (Degree)	RAW VALUE (dBuV)	CORRECTION FACTOR (dB/m)
1	5150.00	62.7 PK	74.0	-11.3	1.52 V	316	57.9	4.8
2	5150.00	48.7 AV	54.0	-5.3	1.52 V	316	43.9	4.8
3	*5190.00	107.9 PK			1.47 V	326	69.2	38.7
4	*5190.00	98.2 AV			1.47 V	326	59.5	38.7
5	#10380.00	58.8 PK	74.0	-15.2	1.56 V	171	41.2	17.6
6	#10380.00	45.8 AV	54.0	-8.2	1.56 V	171	28.2	17.6

Remarks:

1. Emission Level(dBuV/m) = Raw Value(dBuV) + Correction Factor(dB/m)
2. Correction Factor(dB/m) = Antenna Factor(dB/m) + Cable Factor(dB) – Pre-Amplifier Factor(dB)
3. The other emission levels were very low against the limit.
4. Margin value = Emission Level – Limit value
5. " * ": Fundamental frequency.
6. " # ": The radiated frequency is out of the restricted band.

CHANNEL	TX Channel 46	DETECTOR FUNCTION	Peak (PK)
FREQUENCY RANGE	1GHz ~ 40GHz		Average (AV)

ANTENNA POLARITY & TEST DISTANCE: HORIZONTAL AT 3 M								
NO.	FREQ. (MHz)	EMISSION LEVEL (dBuV/m)	LIMIT (dBuV/m)	MARGIN (dB)	ANTENNA HEIGHT (m)	TABLE ANGLE (Degree)	RAW VALUE (dBuV)	CORRECTION FACTOR (dB/m)
1	*5230.00	105.9 PK			1.67 H	325	67.0	38.9
2	*5230.00	96.6 AV			1.67 H	325	57.7	38.9
3	5350.00	56.8 PK	74.0	-17.2	1.78 H	216	51.3	5.5
4	5350.00	44.0 AV	54.0	-10.0	1.78 H	216	38.5	5.5
5	#10460.00	58.6 PK	74.0	-15.4	1.76 H	234	40.4	18.2
6	#10460.00	46.3 AV	54.0	-7.7	1.76 H	234	28.1	18.2

ANTENNA POLARITY & TEST DISTANCE: VERTICAL AT 3 M								
NO.	FREQ. (MHz)	EMISSION LEVEL (dBuV/m)	LIMIT (dBuV/m)	MARGIN (dB)	ANTENNA HEIGHT (m)	TABLE ANGLE (Degree)	RAW VALUE (dBuV)	CORRECTION FACTOR (dB/m)
1	*5230.00	109.4 PK			1.51 V	326	70.5	38.9
2	*5230.00	99.8 AV			1.51 V	326	60.9	38.9
3	5350.00	56.8 PK	74.0	-17.2	1.34 V	322	51.3	5.5
4	5350.00	44.8 AV	54.0	-9.2	1.34 V	322	39.3	5.5
5	#10460.00	58.5 PK	74.0	-15.5	1.23 V	211	40.3	18.2
6	#10460.00	46.3 AV	54.0	-7.7	1.23 V	211	28.1	18.2

Remarks:

1. Emission Level(dBuV/m) = Raw Value(dBuV) + Correction Factor(dB/m)
2. Correction Factor(dB/m) = Antenna Factor(dB/m) + Cable Factor(dB) – Pre-Amplifier Factor(dB)
3. The other emission levels were very low against the limit.
4. Margin value = Emission Level – Limit value
5. " * ": Fundamental frequency.
6. " # ": The radiated frequency is out of the restricted band.

CHANNEL	TX Channel 151	DETECTOR FUNCTION	Peak (PK)
FREQUENCY RANGE	1GHz ~ 40GHz		Average (AV)

ANTENNA POLARITY & TEST DISTANCE: HORIZONTAL AT 3 M

NO.	FREQ. (MHz)	EMISSION LEVEL (dBuV/m)	LIMIT (dBuV/m)	MARGIN (dB)	ANTENNA HEIGHT (m)	TABLE ANGLE (Degree)	RAW VALUE (dBuV)	CORRECTION FACTOR (dB/m)
1	*5755.00	114.2 PK			2.29 H	2	74.2	40.0
2	*5755.00	105.0 AV			2.29 H	2	65.0	40.0
3	11510.00	59.9 PK	74.0	-14.1	2.56 H	153	40.6	19.3
4	11510.00	47.6 AV	54.0	-6.4	2.56 H	153	28.3	19.3

ANTENNA POLARITY & TEST DISTANCE: VERTICAL AT 3 M

NO.	FREQ. (MHz)	EMISSION LEVEL (dBuV/m)	LIMIT (dBuV/m)	MARGIN (dB)	ANTENNA HEIGHT (m)	TABLE ANGLE (Degree)	RAW VALUE (dBuV)	CORRECTION FACTOR (dB/m)
1	*5755.00	115.9 PK			2.04 V	346	75.9	40.0
2	*5755.00	105.9 AV			2.04 V	346	65.9	40.0
3	11510.00	61.7 PK	74.0	-12.3	1.88 V	158	42.4	19.3
4	11510.00	48.7 AV	54.0	-5.3	1.88 V	158	29.4	19.3

Remarks:

1. Emission Level(dBuV/m) = Raw Value(dBuV) + Correction Factor(dB/m)
2. Correction Factor(dB/m) = Antenna Factor(dB/m) + Cable Factor(dB) – Pre-Amplifier Factor(dB)
3. The other emission levels were very low against the limit.
4. Margin value = Emission Level – Limit value
5. " * ": Fundamental frequency.
6. " # ": The radiated frequency is out of the restricted band.

CHANNEL	TX Channel 159	DETECTOR FUNCTION	Peak (PK)
FREQUENCY RANGE	1GHz ~ 40GHz		Average (AV)

ANTENNA POLARITY & TEST DISTANCE: HORIZONTAL AT 3 M								
NO.	FREQ. (MHz)	EMISSION LEVEL (dBuV/m)	LIMIT (dBuV/m)	MARGIN (dB)	ANTENNA HEIGHT (m)	TABLE ANGLE (Degree)	RAW VALUE (dBuV)	CORRECTION FACTOR (dB/m)
1	*5795.00	110.2 PK			2.30 H	341	70.1	40.1
2	*5795.00	101.3 AV			2.30 H	341	61.2	40.1
3	11590.00	61.7 PK	74.0	-12.3	2.15 H	138	42.5	19.2
4	11590.00	48.1 AV	54.0	-5.9	2.15 H	138	28.9	19.2
ANTENNA POLARITY & TEST DISTANCE: VERTICAL AT 3 M								
NO.	FREQ. (MHz)	EMISSION LEVEL (dBuV/m)	LIMIT (dBuV/m)	MARGIN (dB)	ANTENNA HEIGHT (m)	TABLE ANGLE (Degree)	RAW VALUE (dBuV)	CORRECTION FACTOR (dB/m)
1	*5795.00	115.1 PK			1.96 V	342	75.0	40.1
2	*5795.00	105.0 AV			1.96 V	342	64.9	40.1
3	11590.00	62.9 PK	74.0	-11.1	1.95 V	159	43.7	19.2
4	11590.00	50.7 AV	54.0	-3.3	1.95 V	159	31.5	19.2

Remarks:

1. Emission Level(dBuV/m) = Raw Value(dBuV) + Correction Factor(dB/m)
2. Correction Factor(dB/m) = Antenna Factor(dB/m) + Cable Factor(dB) – Pre-Amplifier Factor(dB)
3. The other emission levels were very low against the limit.
4. Margin value = Emission Level – Limit value
5. " * ": Fundamental frequency.
6. " # ": The radiated frequency is out of the restricted band.

802.11ac (VHT80)

CHANNEL	TX Channel 42	DETECTOR FUNCTION	Peak (PK) Average (AV)
FREQUENCY RANGE	1GHz ~ 40GHz		

ANTENNA POLARITY & TEST DISTANCE: HORIZONTAL AT 3 M

NO.	FREQ. (MHz)	EMISSION LEVEL (dBuV/m)	LIMIT (dBuV/m)	MARGIN (dB)	ANTENNA HEIGHT (m)	TABLE ANGLE (Degree)	RAW VALUE (dBuV)	CORRECTION FACTOR (dB/m)
1	5150.00	64.6 PK	74.0	-9.4	2.60 H	6	59.8	4.8
2	5150.00	51.9 AV	54.0	-2.1	2.60 H	6	47.1	4.8
3	*5210.00	103.2 PK			2.11 H	341	64.5	38.7
4	*5210.00	92.7 AV			2.11 H	341	54.0	38.7
5	5350.00	56.8 PK	74.0	-17.2	2.00 H	324	51.3	5.5
6	5350.00	44.0 AV	54.0	-10.0	2.00 H	324	38.5	5.5
7	#10420.00	58.7 PK	74.0	-15.3	1.81 H	139	40.9	17.8
8	#10420.00	46.2 AV	54.0	-7.8	1.81 H	139	28.4	17.8

ANTENNA POLARITY & TEST DISTANCE: VERTICAL AT 3 M

NO.	FREQ. (MHz)	EMISSION LEVEL (dBuV/m)	LIMIT (dBuV/m)	MARGIN (dB)	ANTENNA HEIGHT (m)	TABLE ANGLE (Degree)	RAW VALUE (dBuV)	CORRECTION FACTOR (dB/m)
1	5150.00	62.7 PK	74.0	-11.3	1.50 V	317	57.9	4.8
2	5150.00	50.8 AV	54.0	-3.2	1.50 V	317	46.0	4.8
3	*5210.00	105.3 PK			1.40 V	332	66.6	38.7
4	*5210.00	95.4 AV			1.40 V	332	56.7	38.7
5	5350.00	56.8 PK	74.0	-17.2	1.86 V	282	51.3	5.5
6	5350.00	44.8 AV	54.0	-9.2	1.86 V	282	39.3	5.5
7	#10420.00	58.7 PK	74.0	-15.3	1.69 V	166	40.9	17.8
8	#10420.00	46.4 AV	54.0	-7.6	1.69 V	166	28.6	17.8

Remarks:

1. Emission Level(dBuV/m) = Raw Value(dBuV) + Correction Factor(dB/m)
2. Correction Factor(dB/m) = Antenna Factor(dB/m) + Cable Factor(dB) – Pre-Amplifier Factor(dB)
3. The other emission levels were very low against the limit.
4. Margin value = Emission Level – Limit value
5. " * ": Fundamental frequency.
6. " # ": The radiated frequency is out of the restricted band.

CHANNEL	TX Channel 155	DETECTOR FUNCTION	Peak (PK)
FREQUENCY RANGE	1GHz ~ 40GHz		Average (AV)

ANTENNA POLARITY & TEST DISTANCE: HORIZONTAL AT 3 M								
NO.	FREQ. (MHz)	EMISSION LEVEL (dBuV/m)	LIMIT (dBuV/m)	MARGIN (dB)	ANTENNA HEIGHT (m)	TABLE ANGLE (Degree)	RAW VALUE (dBuV)	CORRECTION FACTOR (dB/m)
1	#5643.00	65.2 PK	68.2	-3.0	1.98 H	324	59.1	6.1
2	*5775.00	107.7 PK			2.07 H	345	67.7	40.0
3	*5775.00	97.7 AV			2.07 H	345	57.7	40.0
4	11550.00	60.1 PK	74.0	-13.9	1.57 H	138	40.9	19.2
5	11550.00	47.2 AV	54.0	-6.8	1.57 H	138	28.0	19.2

ANTENNA POLARITY & TEST DISTANCE: VERTICAL AT 3 M								
NO.	FREQ. (MHz)	EMISSION LEVEL (dBuV/m)	LIMIT (dBuV/m)	MARGIN (dB)	ANTENNA HEIGHT (m)	TABLE ANGLE (Degree)	RAW VALUE (dBuV)	CORRECTION FACTOR (dB/m)
1	#5644.00	66.9 PK	68.2	-1.3	2.36 V	345	60.8	6.1
2	*5775.00	109.1 PK			1.91 V	340	69.1	40.0
3	*5775.00	99.3 AV			1.91 V	340	59.3	40.0
4	11550.00	60.0 PK	74.0	-14.0	1.79 V	163	40.8	19.2
5	11550.00	47.2 AV	54.0	-6.8	1.79 V	163	28.0	19.2

Remarks:

1. Emission Level(dBuV/m) = Raw Value(dBuV) + Correction Factor(dB/m)
2. Correction Factor(dB/m) = Antenna Factor(dB/m) + Cable Factor(dB) – Pre-Amplifier Factor(dB)
3. The other emission levels were very low against the limit.
4. Margin value = Emission Level – Limit value
5. " * ": Fundamental frequency.
6. " # ": The radiated frequency is out of the restricted band.

Below 1GHz Worst-Case Data:

802.11a

CHANNEL	TX Channel 149	DETECTOR FUNCTION	Quasi-Peak (QP)
FREQUENCY RANGE	9kHz ~ 1GHz		

ANTENNA POLARITY & TEST DISTANCE: HORIZONTAL AT 3 M								
NO.	FREQ. (MHz)	EMISSION LEVEL (dBuV/m)	LIMIT (dBuV/m)	MARGIN (dB)	ANTENNA HEIGHT (m)	TABLE ANGLE (Degree)	RAW VALUE (dBuV)	CORRECTION FACTOR (dB/m)
1	57.12	29.7 QP	40.0	-10.3	1.99 H	230	44.3	-14.6
2	156.28	29.7 QP	43.5	-13.8	1.49 H	109	43.5	-13.8
3	183.50	30.4 QP	43.5	-13.1	1.99 H	95	45.9	-15.5
4	249.60	34.7 QP	46.0	-11.3	1.00 H	172	48.7	-14.0
5	374.04	42.1 QP	46.0	-3.9	1.00 H	144	52.6	-10.5
6	875.67	40.1 QP	46.0	-5.9	1.49 H	44	40.2	-0.1
ANTENNA POLARITY & TEST DISTANCE: VERTICAL AT 3 M								
NO.	FREQ. (MHz)	EMISSION LEVEL (dBuV/m)	LIMIT (dBuV/m)	MARGIN (dB)	ANTENNA HEIGHT (m)	TABLE ANGLE (Degree)	RAW VALUE (dBuV)	CORRECTION FACTOR (dB/m)
1	57.12	36.7 QP	40.0	-3.3	1.00 V	15	51.3	-14.6
2	125.17	29.5 QP	43.5	-14.0	1.00 V	213	45.6	-16.1
3	185.44	28.7 QP	43.5	-14.8	1.00 V	112	44.5	-15.8
4	249.60	32.7 QP	46.0	-13.3	1.00 V	114	46.7	-14.0
5	374.04	43.6 QP	46.0	-2.4	1.50 V	98	54.1	-10.5
6	875.67	40.9 QP	46.0	-5.1	1.00 V	160	41.0	-0.1

Remarks:

1. Emission Level(dBuV/m) = Raw Value(dBuV) + Correction Factor(dB/m)
2. Correction Factor(dB/m) = Antenna Factor(dB/m) + Cable Factor(dB) – Pre-Amplifier Factor(dB)
3. The other emission levels were very low against the limit.
4. Margin value = Emission Level – Limit value

Test Mode D

Above 1GHz worst-Case Data:

802.11a

CHANNEL	TX Channel 36	DETECTOR FUNCTION	Peak (PK)
FREQUENCY RANGE	1GHz ~ 40GHz		Average (AV)

ANTENNA POLARITY & TEST DISTANCE: HORIZONTAL AT 3 M

NO.	FREQ. (MHz)	EMISSION LEVEL (dBuV/m)	LIMIT (dBuV/m)	MARGIN (dB)	ANTENNA HEIGHT (m)	TABLE ANGLE (Degree)	RAW VALUE (dBuV)	CORRECTION FACTOR (dB/m)
1	4823.00	57.0 PK	74.0	-17.0	1.70 H	336	53.2	3.8
2	4823.00	46.3 AV	54.0	-7.7	1.70 H	336	42.5	3.8
3	*5180.00	108.1 PK			1.82 H	339	69.4	38.7
4	*5180.00	97.3 AV			1.82 H	339	58.6	38.7
5	#10360.00	59.0 PK	74.0	-15.0	1.59 H	288	41.4	17.6
6	#10360.00	46.0 AV	54.0	-8.0	1.59 H	288	28.4	17.6

ANTENNA POLARITY & TEST DISTANCE: VERTICAL AT 3 M

NO.	FREQ. (MHz)	EMISSION LEVEL (dBuV/m)	LIMIT (dBuV/m)	MARGIN (dB)	ANTENNA HEIGHT (m)	TABLE ANGLE (Degree)	RAW VALUE (dBuV)	CORRECTION FACTOR (dB/m)
1	4823.00	54.0 PK	74.0	-20.0	1.83 V	346	50.2	3.8
2	4823.00	44.0 AV	54.0	-10.0	1.83 V	346	40.2	3.8
3	*5180.00	107.2 PK			1.79 V	1	68.5	38.7
4	*5180.00	96.7 AV			1.79 V	1	58.0	38.7
5	#10380.00	57.5 PK	74.0	-16.5	1.61 V	264	39.9	17.6
6	#10380.00	45.1 AV	54.0	-8.9	1.61 V	264	27.5	17.6

Remarks:

1. Emission Level(dBuV/m) = Raw Value(dBuV) + Correction Factor(dB/m)
2. Correction Factor(dB/m) = Antenna Factor(dB/m) + Cable Factor(dB) – Pre-Amplifier Factor(dB)
3. The other emission levels were very low against the limit.
4. Margin value = Emission Level – Limit value
5. " * ": Fundamental frequency.
6. " # ": The radiated frequency is out of the restricted band.

CHANNEL	TX Channel 40	DETECTOR FUNCTION	Peak (PK)
FREQUENCY RANGE	1GHz ~ 40GHz		Average (AV)

ANTENNA POLARITY & TEST DISTANCE: HORIZONTAL AT 3 M								
NO.	FREQ. (MHz)	EMISSION LEVEL (dBuV/m)	LIMIT (dBuV/m)	MARGIN (dB)	ANTENNA HEIGHT (m)	TABLE ANGLE (Degree)	RAW VALUE (dBuV)	CORRECTION FACTOR (dB/m)
1	*5200.00	108.4 PK			1.75 H	352	69.7	38.7
2	*5200.00	97.3 AV			1.75 H	352	58.6	38.7
3	#10400.00	58.4 PK	74.0	-15.6	1.67 H	292	40.8	17.6
4	#10400.00	45.8 AV	54.0	-8.2	1.67 H	292	28.2	17.6
ANTENNA POLARITY & TEST DISTANCE: VERTICAL AT 3 M								
NO.	FREQ. (MHz)	EMISSION LEVEL (dBuV/m)	LIMIT (dBuV/m)	MARGIN (dB)	ANTENNA HEIGHT (m)	TABLE ANGLE (Degree)	RAW VALUE (dBuV)	CORRECTION FACTOR (dB/m)
1	*5200.00	108.4 PK			1.75 V	355	69.7	38.7
2	*5200.00	97.0 AV			1.75 V	355	58.3	38.7
3	#10400.00	58.3 PK	74.0	-15.7	1.64 V	283	40.7	17.6
4	#10400.00	45.3 AV	54.0	-8.7	1.64 V	283	27.7	17.6

Remarks:

1. Emission Level(dBuV/m) = Raw Value(dBuV) + Correction Factor(dB/m)
2. Correction Factor(dB/m) = Antenna Factor(dB/m) + Cable Factor(dB) – Pre-Amplifier Factor(dB)
3. The other emission levels were very low against the limit.
4. Margin value = Emission Level – Limit value
5. " * ": Fundamental frequency.
6. " # ": The radiated frequency is out of the restricted band.

CHANNEL	TX Channel 48	DETECTOR FUNCTION	Peak (PK)
FREQUENCY RANGE	1GHz ~ 40GHz		Average (AV)

ANTENNA POLARITY & TEST DISTANCE: HORIZONTAL AT 3 M								
NO.	FREQ. (MHz)	EMISSION LEVEL (dBuV/m)	LIMIT (dBuV/m)	MARGIN (dB)	ANTENNA HEIGHT (m)	TABLE ANGLE (Degree)	RAW VALUE (dBuV)	CORRECTION FACTOR (dB/m)
1	*5240.00	108.8 PK			1.80 H	351	69.9	38.9
2	*5240.00	97.6 AV			1.80 H	351	58.7	38.9
3	5350.00	57.2 PK	74.0	-16.8	1.69 H	342	51.7	5.5
4	5350.00	46.3 AV	54.0	-7.7	1.69 H	342	40.8	5.5
5	#10480.00	58.2 PK	74.0	-15.8	1.63 H	289	39.8	18.4
6	#10480.00	45.7 AV	54.0	-8.3	1.63 H	289	27.3	18.4

ANTENNA POLARITY & TEST DISTANCE: VERTICAL AT 3 M								
NO.	FREQ. (MHz)	EMISSION LEVEL (dBuV/m)	LIMIT (dBuV/m)	MARGIN (dB)	ANTENNA HEIGHT (m)	TABLE ANGLE (Degree)	RAW VALUE (dBuV)	CORRECTION FACTOR (dB/m)
1	*5240.00	107.7 PK			1.80 V	359	68.8	38.9
2	*5240.00	97.3 AV			1.80 V	359	58.4	38.9
3	5350.00	55.9 PK	74.0	-18.1	1.69 V	346	50.4	5.5
4	5350.00	43.6 AV	54.0	-10.4	1.69 V	346	38.1	5.5
5	#10480.00	57.8 PK	74.0	-16.2	1.59 V	288	39.4	18.4
6	#10480.00	45.3 AV	54.0	-8.7	1.59 V	288	26.9	18.4

Remarks:

1. Emission Level(dBuV/m) = Raw Value(dBuV) + Correction Factor(dB/m)
2. Correction Factor(dB/m) = Antenna Factor(dB/m) + Cable Factor(dB) – Pre-Amplifier Factor(dB)
3. The other emission levels were very low against the limit.
4. Margin value = Emission Level – Limit value
5. " * ": Fundamental frequency.
6. " # ": The radiated frequency is out of the restricted band.

CHANNEL	TX Channel 149	DETECTOR FUNCTION	Peak (PK)
FREQUENCY RANGE	1GHz ~ 40GHz		Average (AV)

ANTENNA POLARITY & TEST DISTANCE: HORIZONTAL AT 3 M

NO.	FREQ. (MHz)	EMISSION LEVEL (dBuV/m)	LIMIT (dBuV/m)	MARGIN (dB)	ANTENNA HEIGHT (m)	TABLE ANGLE (Degree)	RAW VALUE (dBuV)	CORRECTION FACTOR (dB/m)
1	*5745.00	121.9 PK			1.72 H	344	81.9	40.0
2	*5745.00	110.3 AV			1.72 H	344	70.3	40.0
3	11490.00	59.6 PK	74.0	-14.4	1.73 H	136	40.3	19.3
4	11490.00	47.4 AV	54.0	-6.6	1.73 H	136	28.1	19.3

ANTENNA POLARITY & TEST DISTANCE: VERTICAL AT 3 M

NO.	FREQ. (MHz)	EMISSION LEVEL (dBuV/m)	LIMIT (dBuV/m)	MARGIN (dB)	ANTENNA HEIGHT (m)	TABLE ANGLE (Degree)	RAW VALUE (dBuV)	CORRECTION FACTOR (dB/m)
1	*5745.00	120.4 PK			1.68 V	352	80.4	40.0
2	*5745.00	109.8 AV			1.68 V	352	69.8	40.0
3	11490.00	61.5 PK	74.0	-12.5	1.80 V	165	42.2	19.3
4	11490.00	49.0 AV	54.0	-5.0	1.80 V	165	29.7	19.3

Remarks:

1. Emission Level(dBuV/m) = Raw Value(dBuV) + Correction Factor(dB/m)
2. Correction Factor(dB/m) = Antenna Factor(dB/m) + Cable Factor(dB) – Pre-Amplifier Factor(dB)
3. The other emission levels were very low against the limit.
4. Margin value = Emission Level – Limit value
5. " * ": Fundamental frequency.
6. " # ": The radiated frequency is out of the restricted band.

CHANNEL	TX Channel 157	DETECTOR FUNCTION	Peak (PK)
FREQUENCY RANGE	1GHz ~ 40GHz		Average (AV)

ANTENNA POLARITY & TEST DISTANCE: HORIZONTAL AT 3 M								
NO.	FREQ. (MHz)	EMISSION LEVEL (dBuV/m)	LIMIT (dBuV/m)	MARGIN (dB)	ANTENNA HEIGHT (m)	TABLE ANGLE (Degree)	RAW VALUE (dBuV)	CORRECTION FACTOR (dB/m)
1	*5785.00	123.6 PK			1.78 H	342	83.5	40.1
2	*5785.00	112.3 AV			1.78 H	342	72.2	40.1
3	11570.00	61.5 PK	74.0	-12.5	2.21 H	53	42.3	19.2
4	11570.00	48.3 AV	54.0	-5.7	2.21 H	53	29.1	19.2
ANTENNA POLARITY & TEST DISTANCE: VERTICAL AT 3 M								
NO.	FREQ. (MHz)	EMISSION LEVEL (dBuV/m)	LIMIT (dBuV/m)	MARGIN (dB)	ANTENNA HEIGHT (m)	TABLE ANGLE (Degree)	RAW VALUE (dBuV)	CORRECTION FACTOR (dB/m)
1	*5785.00	120.7 PK			1.70 V	350	80.6	40.1
2	*5785.00	110.2 AV			1.70 V	350	70.1	40.1
3	11570.00	63.7 PK	74.0	-10.3	1.85 V	171	44.5	19.2
4	11570.00	50.3 AV	54.0	-3.7	1.85 V	171	31.1	19.2

Remarks:

1. Emission Level(dBuV/m) = Raw Value(dBuV) + Correction Factor(dB/m)
2. Correction Factor(dB/m) = Antenna Factor(dB/m) + Cable Factor(dB) – Pre-Amplifier Factor(dB)
3. The other emission levels were very low against the limit.
4. Margin value = Emission Level – Limit value
5. " * ": Fundamental frequency.

CHANNEL	TX Channel 165	DETECTOR FUNCTION	Peak (PK)
FREQUENCY RANGE	1GHz ~ 40GHz		Average (AV)

ANTENNA POLARITY & TEST DISTANCE: HORIZONTAL AT 3 M								
NO.	FREQ. (MHz)	EMISSION LEVEL (dBuV/m)	LIMIT (dBuV/m)	MARGIN (dB)	ANTENNA HEIGHT (m)	TABLE ANGLE (Degree)	RAW VALUE (dBuV)	CORRECTION FACTOR (dB/m)
1	*5825.00	122.6 PK			1.77 H	341	82.5	40.1
2	*5825.00	111.2 AV			1.77 H	341	71.1	40.1
3	11650.00	60.8 PK	74.0	-13.2	1.67 H	139	41.5	19.3
4	11650.00	48.4 AV	54.0	-5.6	1.67 H	139	29.1	19.3
ANTENNA POLARITY & TEST DISTANCE: VERTICAL AT 3 M								
NO.	FREQ. (MHz)	EMISSION LEVEL (dBuV/m)	LIMIT (dBuV/m)	MARGIN (dB)	ANTENNA HEIGHT (m)	TABLE ANGLE (Degree)	RAW VALUE (dBuV)	CORRECTION FACTOR (dB/m)
1	*5825.00	121.2 PK			1.67 V	351	81.1	40.1
2	*5825.00	110.8 AV			1.67 V	351	70.7	40.1
3	11650.00	64.6 PK	74.0	-9.4	1.81 V	169	45.3	19.3
4	11650.00	51.9 AV	54.0	-2.1	1.81 V	169	32.6	19.3

Remarks:

1. Emission Level(dBuV/m) = Raw Value(dBuV) + Correction Factor(dB/m)
2. Correction Factor(dB/m) = Antenna Factor(dB/m) + Cable Factor(dB) – Pre-Amplifier Factor(dB)
3. The other emission levels were very low against the limit.
4. Margin value = Emission Level – Limit value
5. " * ": Fundamental frequency.
6. " # ": The radiated frequency is out of the restricted band.

802.11n (HT20)

CHANNEL	TX Channel 36	DETECTOR FUNCTION	Peak (PK) Average (AV)
FREQUENCY RANGE	1GHz ~ 40GHz		

ANTENNA POLARITY & TEST DISTANCE: HORIZONTAL AT 3 M

NO.	FREQ. (MHz)	EMISSION LEVEL (dBuV/m)	LIMIT (dBuV/m)	MARGIN (dB)	ANTENNA HEIGHT (m)	TABLE ANGLE (Degree)	RAW VALUE (dBuV)	CORRECTION FACTOR (dB/m)
1	4823.00	57.2 PK	74.0	-16.8	1.68 H	335	53.4	3.8
2	4823.00	49.1 AV	54.0	-4.9	1.68 H	335	45.3	3.8
3	*5180.00	107.8 PK			1.81 H	350	69.1	38.7
4	*5180.00	97.2 AV			1.81 H	350	58.5	38.7
5	#10360.00	58.4 PK	74.0	-15.6	1.59 H	293	40.8	17.6
6	#10360.00	45.7 AV	54.0	-8.3	1.59 H	293	28.1	17.6

ANTENNA POLARITY & TEST DISTANCE: VERTICAL AT 3 M

NO.	FREQ. (MHz)	EMISSION LEVEL (dBuV/m)	LIMIT (dBuV/m)	MARGIN (dB)	ANTENNA HEIGHT (m)	TABLE ANGLE (Degree)	RAW VALUE (dBuV)	CORRECTION FACTOR (dB/m)
1	4823.00	53.5 PK	74.0	-20.5	1.80 V	357	49.7	3.8
2	4823.00	44.5 AV	54.0	-9.5	1.80 V	357	40.7	3.8
3	*5180.00	107.6 PK			1.72 V	358	68.9	38.7
4	*5180.00	96.8 AV			1.72 V	358	58.1	38.7
5	#10360.00	58.2 PK	74.0	-15.8	1.69 V	296	40.6	17.6
6	#10360.00	45.4 AV	54.0	-8.6	1.69 V	296	27.8	17.6

Remarks:

1. Emission Level(dBuV/m) = Raw Value(dBuV) + Correction Factor(dB/m)
2. Correction Factor(dB/m) = Antenna Factor(dB/m) + Cable Factor(dB) – Pre-Amplifier Factor(dB)
3. The other emission levels were very low against the limit.
4. Margin value = Emission Level – Limit value
5. " * ": Fundamental frequency.
6. " # ": The radiated frequency is out of the restricted band.

CHANNEL	TX Channel 40	DETECTOR FUNCTION	Peak (PK)
FREQUENCY RANGE	1GHz ~ 40GHz		Average (AV)

ANTENNA POLARITY & TEST DISTANCE: HORIZONTAL AT 3 M

NO.	FREQ. (MHz)	EMISSION LEVEL (dBuV/m)	LIMIT (dBuV/m)	MARGIN (dB)	ANTENNA HEIGHT (m)	TABLE ANGLE (Degree)	RAW VALUE (dBuV)	CORRECTION FACTOR (dB/m)
1	*5200.00	108.3 PK			1.77 H	345	69.6	38.7
2	*5200.00	97.4 AV			1.77 H	345	58.7	38.7
3	#10400.00	58.7 PK	74.0	-15.3	1.70 H	305	41.1	17.6
4	#10400.00	45.4 AV	54.0	-8.6	1.70 H	305	27.8	17.6

ANTENNA POLARITY & TEST DISTANCE: VERTICAL AT 3 M

NO.	FREQ. (MHz)	EMISSION LEVEL (dBuV/m)	LIMIT (dBuV/m)	MARGIN (dB)	ANTENNA HEIGHT (m)	TABLE ANGLE (Degree)	RAW VALUE (dBuV)	CORRECTION FACTOR (dB/m)
1	*5200.00	108.2 PK			1.71 V	2	69.5	38.7
2	*5200.00	97.2 AV			1.71 V	2	58.5	38.7
3	#10400.00	58.5 PK	74.0	-15.5	1.64 V	315	40.9	17.6
4	#10400.00	45.3 AV	54.0	-8.7	1.64 V	315	27.7	17.6

Remarks:

1. Emission Level(dBuV/m) = Raw Value(dBuV) + Correction Factor(dB/m)
2. Correction Factor(dB/m) = Antenna Factor(dB/m) + Cable Factor(dB) – Pre-Amplifier Factor(dB)
3. The other emission levels were very low against the limit.
4. Margin value = Emission Level – Limit value
5. " * ": Fundamental frequency.
6. " # ": The radiated frequency is out of the restricted band.

CHANNEL	TX Channel 48	DETECTOR FUNCTION	Peak (PK)
FREQUENCY RANGE	1GHz ~ 40GHz		Average (AV)

ANTENNA POLARITY & TEST DISTANCE: HORIZONTAL AT 3 M

NO.	FREQ. (MHz)	EMISSION LEVEL (dBuV/m)	LIMIT (dBuV/m)	MARGIN (dB)	ANTENNA HEIGHT (m)	TABLE ANGLE (Degree)	RAW VALUE (dBuV)	CORRECTION FACTOR (dB/m)
1	*5240.00	108.2 PK			1.81 H	347	69.3	38.9
2	*5240.00	97.6 AV			1.81 H	347	58.7	38.9
3	5350.00	57.6 PK	74.0	-16.4	1.90 H	347	52.1	5.5
4	5350.00	46.2 AV	54.0	-7.8	1.90 H	347	40.7	5.5
5	#10480.00	58.3 PK	74.0	-15.7	1.75 H	292	39.9	18.4
6	#10480.00	45.5 AV	54.0	-8.5	1.75 H	292	27.1	18.4

ANTENNA POLARITY & TEST DISTANCE: VERTICAL AT 3 M

NO.	FREQ. (MHz)	EMISSION LEVEL (dBuV/m)	LIMIT (dBuV/m)	MARGIN (dB)	ANTENNA HEIGHT (m)	TABLE ANGLE (Degree)	RAW VALUE (dBuV)	CORRECTION FACTOR (dB/m)
1	*5240.00	108.2 PK			1.76 V	359	69.3	38.9
2	*5240.00	97.1 AV			1.76 V	359	58.2	38.9
3	5350.00	55.8 PK	74.0	-18.2	1.65 V	345	50.3	5.5
4	5350.00	43.9 AV	54.0	-10.1	1.65 V	345	38.4	5.5
5	#10480.00	58.3 PK	74.0	-15.7	1.53 V	269	39.9	18.4
6	#10480.00	45.6 AV	54.0	-8.4	1.53 V	269	27.2	18.4

Remarks:

1. Emission Level(dBuV/m) = Raw Value(dBuV) + Correction Factor(dB/m)
2. Correction Factor(dB/m) = Antenna Factor(dB/m) + Cable Factor(dB) – Pre-Amplifier Factor(dB)
3. The other emission levels were very low against the limit.
4. Margin value = Emission Level – Limit value
5. " * ": Fundamental frequency.
6. " # ": The radiated frequency is out of the restricted band.

CHANNEL	TX Channel 149	DETECTOR FUNCTION	Peak (PK)
FREQUENCY RANGE	1GHz ~ 40GHz		Average (AV)

ANTENNA POLARITY & TEST DISTANCE: HORIZONTAL AT 3 M								
NO.	FREQ. (MHz)	EMISSION LEVEL (dBuV/m)	LIMIT (dBuV/m)	MARGIN (dB)	ANTENNA HEIGHT (m)	TABLE ANGLE (Degree)	RAW VALUE (dBuV)	CORRECTION FACTOR (dB/m)
1	*5745.00	122.0 PK			1.73 H	347	82.0	40.0
2	*5745.00	111.0 AV			1.73 H	347	71.0	40.0
3	11490.00	59.7 PK	74.0	-14.3	1.92 H	85	40.4	19.3
4	11490.00	47.4 AV	54.0	-6.6	1.92 H	85	28.1	19.3
ANTENNA POLARITY & TEST DISTANCE: VERTICAL AT 3 M								
NO.	FREQ. (MHz)	EMISSION LEVEL (dBuV/m)	LIMIT (dBuV/m)	MARGIN (dB)	ANTENNA HEIGHT (m)	TABLE ANGLE (Degree)	RAW VALUE (dBuV)	CORRECTION FACTOR (dB/m)
1	*5745.00	120.5 PK			1.71 V	352	80.5	40.0
2	*5745.00	109.7 AV			1.71 V	352	69.7	40.0
3	11490.00	61.6 PK	74.0	-12.4	1.74 V	164	42.3	19.3
4	11490.00	49.3 AV	54.0	-4.7	1.74 V	164	30.0	19.3

Remarks:

1. Emission Level(dBuV/m) = Raw Value(dBuV) + Correction Factor(dB/m)
2. Correction Factor(dB/m) = Antenna Factor(dB/m) + Cable Factor(dB) – Pre-Amplifier Factor(dB)
3. The other emission levels were very low against the limit.
4. Margin value = Emission Level – Limit value
5. " * ": Fundamental frequency.
6. " # ": The radiated frequency is out of the restricted band.

CHANNEL	TX Channel 157	DETECTOR FUNCTION	Peak (PK)
FREQUENCY RANGE	1GHz ~ 40GHz		Average (AV)

ANTENNA POLARITY & TEST DISTANCE: HORIZONTAL AT 3 M								
NO.	FREQ. (MHz)	EMISSION LEVEL (dBuV/m)	LIMIT (dBuV/m)	MARGIN (dB)	ANTENNA HEIGHT (m)	TABLE ANGLE (Degree)	RAW VALUE (dBuV)	CORRECTION FACTOR (dB/m)
1	*5785.00	123.1 PK			1.70 H	348	83.0	40.1
2	*5785.00	112.3 AV			1.70 H	348	72.2	40.1
3	11570.00	60.6 PK	74.0	-13.4	1.69 H	238	41.4	19.2
4	11570.00	48.0 AV	54.0	-6.0	1.69 H	238	28.8	19.2
ANTENNA POLARITY & TEST DISTANCE: VERTICAL AT 3 M								
NO.	FREQ. (MHz)	EMISSION LEVEL (dBuV/m)	LIMIT (dBuV/m)	MARGIN (dB)	ANTENNA HEIGHT (m)	TABLE ANGLE (Degree)	RAW VALUE (dBuV)	CORRECTION FACTOR (dB/m)
1	*5785.00	120.6 PK			1.73 V	350	80.5	40.1
2	*5785.00	110.3 AV			1.73 V	350	70.2	40.1
3	11570.00	62.8 PK	74.0	-11.2	1.72 V	167	43.6	19.2
4	11570.00	50.0 AV	54.0	-4.0	1.72 V	167	30.8	19.2

Remarks:

1. Emission Level(dBuV/m) = Raw Value(dBuV) + Correction Factor(dB/m)
2. Correction Factor(dB/m) = Antenna Factor(dB/m) + Cable Factor(dB) – Pre-Amplifier Factor(dB)
3. The other emission levels were very low against the limit.
4. Margin value = Emission Level – Limit value
5. " * ": Fundamental frequency.

CHANNEL	TX Channel 165	DETECTOR FUNCTION	Peak (PK)
FREQUENCY RANGE	1GHz ~ 40GHz		Average (AV)

ANTENNA POLARITY & TEST DISTANCE: HORIZONTAL AT 3 M

NO.	FREQ. (MHz)	EMISSION LEVEL (dBuV/m)	LIMIT (dBuV/m)	MARGIN (dB)	ANTENNA HEIGHT (m)	TABLE ANGLE (Degree)	RAW VALUE (dBuV)	CORRECTION FACTOR (dB/m)
1	*5825.00	122.7 PK			1.76 H	348	82.6	40.1
2	*5825.00	111.5 AV			1.76 H	348	71.4	40.1
3	11650.00	59.6 PK	74.0	-14.4	1.76 H	113	40.3	19.3
4	11650.00	47.7 AV	54.0	-6.3	1.76 H	113	28.4	19.3

ANTENNA POLARITY & TEST DISTANCE: VERTICAL AT 3 M

NO.	FREQ. (MHz)	EMISSION LEVEL (dBuV/m)	LIMIT (dBuV/m)	MARGIN (dB)	ANTENNA HEIGHT (m)	TABLE ANGLE (Degree)	RAW VALUE (dBuV)	CORRECTION FACTOR (dB/m)
1	*5825.00	120.9 PK			1.69 V	353	80.8	40.1
2	*5825.00	110.5 AV			1.69 V	353	70.4	40.1
3	11650.00	62.8 PK	74.0	-11.2	1.63 V	180	43.5	19.3
4	11650.00	49.8 AV	54.0	-4.2	1.63 V	180	30.5	19.3

Remarks:

1. Emission Level(dBuV/m) = Raw Value(dBuV) + Correction Factor(dB/m)
2. Correction Factor(dB/m) = Antenna Factor(dB/m) + Cable Factor(dB) – Pre-Amplifier Factor(dB)
3. The other emission levels were very low against the limit.
4. Margin value = Emission Level – Limit value
5. " * ": Fundamental frequency.
6. " # ": The radiated frequency is out of the restricted band.

802.11n (HT40)

CHANNEL	TX Channel 38	DETECTOR FUNCTION	Peak (PK) Average (AV)
FREQUENCY RANGE	1GHz ~ 40GHz		

ANTENNA POLARITY & TEST DISTANCE: HORIZONTAL AT 3 M

NO.	FREQ. (MHz)	EMISSION LEVEL (dBuV/m)	LIMIT (dBuV/m)	MARGIN (dB)	ANTENNA HEIGHT (m)	TABLE ANGLE (Degree)	RAW VALUE (dBuV)	CORRECTION FACTOR (dB/m)
1	4823.00	57.3 PK	74.0	-16.7	1.69 H	337	53.5	3.8
2	4823.00	48.9 AV	54.0	-5.1	1.69 H	337	45.1	3.8
3	*5190.00	105.0 PK			1.80 H	338	66.3	38.7
4	*5190.00	94.6 AV			1.80 H	338	55.9	38.7
5	#10380.00	58.0 PK	74.0	-16.0	1.59 H	279	40.4	17.6
6	#10380.00	45.6 AV	54.0	-8.4	1.59 H	279	28.0	17.6

ANTENNA POLARITY & TEST DISTANCE: VERTICAL AT 3 M

NO.	FREQ. (MHz)	EMISSION LEVEL (dBuV/m)	LIMIT (dBuV/m)	MARGIN (dB)	ANTENNA HEIGHT (m)	TABLE ANGLE (Degree)	RAW VALUE (dBuV)	CORRECTION FACTOR (dB/m)
1	4823.00	54.7 PK	74.0	-19.3	1.80 V	353	50.9	3.8
2	4823.00	44.5 AV	54.0	-9.5	1.80 V	353	40.7	3.8
3	*5190.00	104.3 PK			1.71 V	0	65.6	38.7
4	*5190.00	94.7 AV			1.71 V	0	56.0	38.7
5	#10380.00	58.6 PK	74.0	-15.4	1.74 V	301	41.0	17.6
6	#10380.00	45.0 AV	54.0	-9.0	1.74 V	301	27.4	17.6

Remarks:

1. Emission Level(dBuV/m) = Raw Value(dBuV) + Correction Factor(dB/m)
2. Correction Factor(dB/m) = Antenna Factor(dB/m) + Cable Factor(dB) – Pre-Amplifier Factor(dB)
3. The other emission levels were very low against the limit.
4. Margin value = Emission Level – Limit value
5. " * ": Fundamental frequency.
6. " # ": The radiated frequency is out of the restricted band.

CHANNEL	TX Channel 46	DETECTOR FUNCTION	Peak (PK)
FREQUENCY RANGE	1GHz ~ 40GHz		Average (AV)

ANTENNA POLARITY & TEST DISTANCE: HORIZONTAL AT 3 M

NO.	FREQ. (MHz)	EMISSION LEVEL (dBuV/m)	LIMIT (dBuV/m)	MARGIN (dB)	ANTENNA HEIGHT (m)	TABLE ANGLE (Degree)	RAW VALUE (dBuV)	CORRECTION FACTOR (dB/m)
1	*5230.00	105.2 PK			1.81 H	348	66.3	38.9
2	*5230.00	94.9 AV			1.81 H	348	56.0	38.9
3	5350.00	56.2 PK	74.0	-17.8	1.91 H	332	50.7	5.5
4	5350.00	46.8 AV	54.0	-7.2	1.91 H	332	41.3	5.5
5	#10460.00	58.4 PK	74.0	-15.6	1.82 H	299	40.2	18.2
6	#10460.00	45.6 AV	54.0	-8.4	1.82 H	299	27.4	18.2

ANTENNA POLARITY & TEST DISTANCE: VERTICAL AT 3 M

NO.	FREQ. (MHz)	EMISSION LEVEL (dBuV/m)	LIMIT (dBuV/m)	MARGIN (dB)	ANTENNA HEIGHT (m)	TABLE ANGLE (Degree)	RAW VALUE (dBuV)	CORRECTION FACTOR (dB/m)
1	*5230.00	104.2 PK			1.74 V	0	65.3	38.9
2	*5230.00	94.7 AV			1.74 V	0	55.8	38.9
3	5350.00	55.8 PK	74.0	-18.2	1.65 V	344	50.3	5.5
4	5350.00	43.7 AV	54.0	-10.3	1.65 V	344	38.2	5.5
5	#10460.00	57.7 PK	74.0	-16.3	1.55 V	265	39.5	18.2
6	#10460.00	45.1 AV	54.0	-8.9	1.55 V	265	26.9	18.2

Remarks:

1. Emission Level(dBuV/m) = Raw Value(dBuV) + Correction Factor(dB/m)
2. Correction Factor(dB/m) = Antenna Factor(dB/m) + Cable Factor(dB) – Pre-Amplifier Factor(dB)
3. The other emission levels were very low against the limit.
4. Margin value = Emission Level – Limit value
5. " * ": Fundamental frequency.
6. " # ": The radiated frequency is out of the restricted band.

CHANNEL	TX Channel 151	DETECTOR FUNCTION	Peak (PK)
FREQUENCY RANGE	1GHz ~ 40GHz		Average (AV)

ANTENNA POLARITY & TEST DISTANCE: HORIZONTAL AT 3 M								
NO.	FREQ. (MHz)	EMISSION LEVEL (dBuV/m)	LIMIT (dBuV/m)	MARGIN (dB)	ANTENNA HEIGHT (m)	TABLE ANGLE (Degree)	RAW VALUE (dBuV)	CORRECTION FACTOR (dB/m)
1	*5755.00	118.3 PK			1.76 H	345	78.3	40.0
2	*5755.00	108.7 AV			1.76 H	345	68.7	40.0
3	11510.00	59.7 PK	74.0	-14.3	1.80 H	90	40.4	19.3
4	11510.00	47.4 AV	54.0	-6.6	1.80 H	90	28.1	19.3
ANTENNA POLARITY & TEST DISTANCE: VERTICAL AT 3 M								
NO.	FREQ. (MHz)	EMISSION LEVEL (dBuV/m)	LIMIT (dBuV/m)	MARGIN (dB)	ANTENNA HEIGHT (m)	TABLE ANGLE (Degree)	RAW VALUE (dBuV)	CORRECTION FACTOR (dB/m)
1	*5755.00	116.8 PK			1.77 V	349	76.8	40.0
2	*5755.00	107.2 AV			1.77 V	349	67.2	40.0
3	11510.00	61.1 PK	74.0	-12.9	1.60 V	167	41.8	19.3
4	11510.00	48.5 AV	54.0	-5.5	1.60 V	167	29.2	19.3

Remarks:

1. Emission Level(dBuV/m) = Raw Value(dBuV) + Correction Factor(dB/m)
2. Correction Factor(dB/m) = Antenna Factor(dB/m) + Cable Factor(dB) – Pre-Amplifier Factor(dB)
3. The other emission levels were very low against the limit.
4. Margin value = Emission Level – Limit value
5. " * ": Fundamental frequency.
6. " # ": The radiated frequency is out of the restricted band.

CHANNEL	TX Channel 159	DETECTOR FUNCTION	Peak (PK)
FREQUENCY RANGE	1GHz ~ 40GHz		Average (AV)

ANTENNA POLARITY & TEST DISTANCE: HORIZONTAL AT 3 M								
NO.	FREQ. (MHz)	EMISSION LEVEL (dBuV/m)	LIMIT (dBuV/m)	MARGIN (dB)	ANTENNA HEIGHT (m)	TABLE ANGLE (Degree)	RAW VALUE (dBuV)	CORRECTION FACTOR (dB/m)
1	*5795.00	119.3 PK			1.77 H	345	79.2	40.1
2	*5795.00	109.6 AV			1.77 H	345	69.5	40.1
3	11590.00	59.9 PK	74.0	-14.1	1.65 H	99	40.7	19.2
4	11590.00	47.7 AV	54.0	-6.3	1.65 H	99	28.5	19.2
ANTENNA POLARITY & TEST DISTANCE: VERTICAL AT 3 M								
NO.	FREQ. (MHz)	EMISSION LEVEL (dBuV/m)	LIMIT (dBuV/m)	MARGIN (dB)	ANTENNA HEIGHT (m)	TABLE ANGLE (Degree)	RAW VALUE (dBuV)	CORRECTION FACTOR (dB/m)
1	*5795.00	117.6 PK			1.77 V	346	77.5	40.1
2	*5795.00	108.1 AV			1.77 V	346	68.0	40.1
3	11590.00	62.0 PK	74.0	-12.0	1.75 V	172	42.8	19.2
4	11590.00	49.8 AV	54.0	-4.2	1.75 V	172	30.6	19.2

Remarks:

1. Emission Level(dBuV/m) = Raw Value(dBuV) + Correction Factor(dB/m)
2. Correction Factor(dB/m) = Antenna Factor(dB/m) + Cable Factor(dB) – Pre-Amplifier Factor(dB)
3. The other emission levels were very low against the limit.
4. Margin value = Emission Level – Limit value
5. " * ": Fundamental frequency.
6. " # ": The radiated frequency is out of the restricted band.

802.11ac (VHT80)

CHANNEL	TX Channel 42	DETECTOR FUNCTION	Peak (PK) Average (AV)
FREQUENCY RANGE	1GHz ~ 40GHz		

ANTENNA POLARITY & TEST DISTANCE: HORIZONTAL AT 3 M

NO.	FREQ. (MHz)	EMISSION LEVEL (dBuV/m)	LIMIT (dBuV/m)	MARGIN (dB)	ANTENNA HEIGHT (m)	TABLE ANGLE (Degree)	RAW VALUE (dBuV)	CORRECTION FACTOR (dB/m)
1	5150.00	58.1 PK	74.0	-15.9	1.83 H	343	53.3	4.8
2	5150.00	46.3 AV	54.0	-7.7	1.83 H	343	41.5	4.8
3	*5210.00	101.6 PK			1.78 H	348	62.9	38.7
4	*5210.00	90.6 AV			1.78 H	348	51.9	38.7
5	5350.00	56.4 PK	74.0	-17.6	1.86 H	349	50.9	5.5
6	5350.00	44.8 AV	54.0	-9.2	1.86 H	349	39.3	5.5
7	#10420.00	57.9 PK	74.0	-16.1	1.71 H	322	40.1	17.8
8	#10420.00	45.9 AV	54.0	-8.1	1.71 H	322	28.1	17.8

ANTENNA POLARITY & TEST DISTANCE: VERTICAL AT 3 M

NO.	FREQ. (MHz)	EMISSION LEVEL (dBuV/m)	LIMIT (dBuV/m)	MARGIN (dB)	ANTENNA HEIGHT (m)	TABLE ANGLE (Degree)	RAW VALUE (dBuV)	CORRECTION FACTOR (dB/m)
1	5150.00	56.0 PK	74.0	-18.0	1.73 V	348	51.2	4.8
2	5150.00	44.4 AV	54.0	-9.6	1.73 V	348	39.6	4.8
3	*5210.00	101.0 PK			1.76 V	0	62.3	38.7
4	*5210.00	90.8 AV			1.76 V	0	52.1	38.7
5	5350.00	55.7 PK	74.0	-18.3	1.69 V	345	50.2	5.5
6	5350.00	44.0 AV	54.0	-10.0	1.69 V	345	38.5	5.5
7	#10420.00	57.7 PK	74.0	-16.3	1.59 V	301	39.9	17.8
8	#10420.00	45.6 AV	54.0	-8.4	1.59 V	301	27.8	17.8

Remarks:

1. Emission Level(dBuV/m) = Raw Value(dBuV) + Correction Factor(dB/m)
2. Correction Factor(dB/m) = Antenna Factor(dB/m) + Cable Factor(dB) – Pre-Amplifier Factor(dB)
3. The other emission levels were very low against the limit.
4. Margin value = Emission Level – Limit value
5. " * ": Fundamental frequency.
6. " # ": The radiated frequency is out of the restricted band.

CHANNEL	TX Channel 155	DETECTOR FUNCTION	Peak (PK)
FREQUENCY RANGE	1GHz ~ 40GHz		Average (AV)

ANTENNA POLARITY & TEST DISTANCE: HORIZONTAL AT 3 M								
NO.	FREQ. (MHz)	EMISSION LEVEL (dBuV/m)	LIMIT (dBuV/m)	MARGIN (dB)	ANTENNA HEIGHT (m)	TABLE ANGLE (Degree)	RAW VALUE (dBuV)	CORRECTION FACTOR (dB/m)
1	*5775.00	112.3 PK			1.74 H	341	72.3	40.0
2	*5775.00	101.8 AV			1.74 H	341	61.8	40.0
3	11550.00	59.4 PK	74.0	-14.6	1.64 H	264	40.2	19.2
4	11550.00	47.4 AV	54.0	-6.6	1.64 H	264	28.2	19.2
ANTENNA POLARITY & TEST DISTANCE: VERTICAL AT 3 M								
NO.	FREQ. (MHz)	EMISSION LEVEL (dBuV/m)	LIMIT (dBuV/m)	MARGIN (dB)	ANTENNA HEIGHT (m)	TABLE ANGLE (Degree)	RAW VALUE (dBuV)	CORRECTION FACTOR (dB/m)
1	*5775.00	110.1 PK			1.78 V	351	70.1	40.0
2	*5775.00	100.1 AV			1.78 V	351	60.1	40.0
3	11550.00	59.6 PK	74.0	-14.4	1.69 V	156	40.4	19.2
4	11550.00	47.6 AV	54.0	-6.4	1.69 V	156	28.4	19.2

Remarks:

1. Emission Level(dBuV/m) = Raw Value(dBuV) + Correction Factor(dB/m)
2. Correction Factor(dB/m) = Antenna Factor(dB/m) + Cable Factor(dB) – Pre-Amplifier Factor(dB)
3. The other emission levels were very low against the limit.
4. Margin value = Emission Level – Limit value
5. " * ": Fundamental frequency.
6. " # ": The radiated frequency is out of the restricted band.

Below 1GHz Worst-Case Data:

802.11a

CHANNEL	TX Channel 149	DETECTOR FUNCTION	Quasi-Peak (QP)
FREQUENCY RANGE	9kHz ~ 1GHz		

ANTENNA POLARITY & TEST DISTANCE: HORIZONTAL AT 3 M								
NO.	FREQ. (MHz)	EMISSION LEVEL (dBuV/m)	LIMIT (dBuV/m)	MARGIN (dB)	ANTENNA HEIGHT (m)	TABLE ANGLE (Degree)	RAW VALUE (dBuV)	CORRECTION FACTOR (dB/m)
1	37.68	31.3 QP	40.0	-8.7	2.00 H	94	46.6	-15.3
2	125.17	29.2 QP	43.5	-14.3	1.50 H	252	45.3	-16.1
3	177.67	29.3 QP	43.5	-14.2	1.50 H	67	44.1	-14.8
4	249.60	37.3 QP	46.0	-8.7	1.00 H	123	51.3	-14.0
5	374.04	37.9 QP	46.0	-8.1	2.00 H	160	48.4	-10.5
6	875.67	41.6 QP	46.0	-4.4	1.50 H	48	41.7	-0.1
ANTENNA POLARITY & TEST DISTANCE: VERTICAL AT 3 M								
NO.	FREQ. (MHz)	EMISSION LEVEL (dBuV/m)	LIMIT (dBuV/m)	MARGIN (dB)	ANTENNA HEIGHT (m)	TABLE ANGLE (Degree)	RAW VALUE (dBuV)	CORRECTION FACTOR (dB/m)
1	36.63	37.8 QP	40.0	-2.2	1.00 V	84	53.3	-15.5
2	54.54	36.3 QP	40.0	-3.7	1.00 V	282	50.6	-14.3
3	206.83	32.5 QP	43.5	-11.0	1.00 V	246	48.9	-16.4
4	249.60	33.0 QP	46.0	-13.0	1.00 V	85	47.0	-14.0
5	374.04	40.5 QP	46.0	-5.5	1.00 V	165	51.0	-10.5
6	875.67	44.5 QP	46.0	-1.5	2.00 V	139	44.6	-0.1

Remarks:

1. Emission Level(dBuV/m) = Raw Value(dBuV) + Correction Factor(dB/m)
2. Correction Factor(dB/m) = Antenna Factor(dB/m) + Cable Factor(dB) – Pre-Amplifier Factor(dB)
3. The other emission levels were very low against the limit.
4. Margin value = Emission Level – Limit value

Test Mode E

Above 1GHz worst-Case Data:

802.11a

CHANNEL	TX Channel 36	DETECTOR FUNCTION	Peak (PK)
FREQUENCY RANGE	1GHz ~ 40GHz		Average (AV)

ANTENNA POLARITY & TEST DISTANCE: HORIZONTAL AT 3 M

NO.	FREQ. (MHz)	EMISSION LEVEL (dBuV/m)	LIMIT (dBuV/m)	MARGIN (dB)	ANTENNA HEIGHT (m)	TABLE ANGLE (Degree)	RAW VALUE (dBuV)	CORRECTION FACTOR (dB/m)
1	5150.00	62.9 PK	74.0	-11.1	1.65 H	351	58.1	4.8
2	5150.00	49.9 AV	54.0	-4.1	1.65 H	351	45.1	4.8
3	*5180.00	118.7 PK			1.53 H	352	80.0	38.7
4	*5180.00	107.4 AV			1.53 H	352	68.7	38.7
5	#10360.00	59.2 PK	74.0	-14.8	1.64 H	219	41.6	17.6
6	#10360.00	46.3 AV	54.0	-7.7	1.64 H	219	28.7	17.6

ANTENNA POLARITY & TEST DISTANCE: VERTICAL AT 3 M

NO.	FREQ. (MHz)	EMISSION LEVEL (dBuV/m)	LIMIT (dBuV/m)	MARGIN (dB)	ANTENNA HEIGHT (m)	TABLE ANGLE (Degree)	RAW VALUE (dBuV)	CORRECTION FACTOR (dB/m)
1	5150.00	62.8 PK	74.0	-11.2	1.40 V	344	58.0	4.8
2	5150.00	49.3 AV	54.0	-4.7	1.40 V	344	44.5	4.8
3	*5180.00	117.2 PK			1.63 V	346	78.5	38.7
4	*5180.00	107.5 AV			1.63 V	346	68.8	38.7
5	#10360.00	59.2 PK	74.0	-14.8	1.59 V	166	41.6	17.6
6	#10360.00	45.9 AV	54.0	-8.1	1.59 V	166	28.3	17.6

Remarks:

1. Emission Level(dBuV/m) = Raw Value(dBuV) + Correction Factor(dB/m)
2. Correction Factor(dB/m) = Antenna Factor(dB/m) + Cable Factor(dB) – Pre-Amplifier Factor(dB)
3. The other emission levels were very low against the limit.
4. Margin value = Emission Level – Limit value
5. " * ": Fundamental frequency.
6. " # ": The radiated frequency is out of the restricted band.

CHANNEL	TX Channel 40	DETECTOR FUNCTION	Peak (PK)
FREQUENCY RANGE	1GHz ~ 40GHz		Average (AV)

ANTENNA POLARITY & TEST DISTANCE: HORIZONTAL AT 3 M								
NO.	FREQ. (MHz)	EMISSION LEVEL (dBuV/m)	LIMIT (dBuV/m)	MARGIN (dB)	ANTENNA HEIGHT (m)	TABLE ANGLE (Degree)	RAW VALUE (dBuV)	CORRECTION FACTOR (dB/m)
1	*5200.00	117.6 PK			1.78 H	352	78.9	38.7
2	*5200.00	106.4 AV			1.78 H	352	67.7	38.7
3	#10400.00	58.3 PK	74.0	-15.7	1.62 H	282	40.7	17.6
4	#10400.00	45.9 AV	54.0	-8.1	1.62 H	282	28.3	17.6
ANTENNA POLARITY & TEST DISTANCE: VERTICAL AT 3 M								
NO.	FREQ. (MHz)	EMISSION LEVEL (dBuV/m)	LIMIT (dBuV/m)	MARGIN (dB)	ANTENNA HEIGHT (m)	TABLE ANGLE (Degree)	RAW VALUE (dBuV)	CORRECTION FACTOR (dB/m)
1	*5200.00	117.5 PK			1.49 V	342	78.8	38.7
2	*5200.00	107.5 AV			1.49 V	342	68.8	38.7
3	#10400.00	58.2 PK	74.0	-15.8	1.49 V	186	40.6	17.6
4	#10400.00	45.8 AV	54.0	-8.2	1.49 V	186	28.2	17.6

Remarks:

1. Emission Level(dBuV/m) = Raw Value(dBuV) + Correction Factor(dB/m)
2. Correction Factor(dB/m) = Antenna Factor(dB/m) + Cable Factor(dB) – Pre-Amplifier Factor(dB)
3. The other emission levels were very low against the limit.
4. Margin value = Emission Level – Limit value
5. " * ": Fundamental frequency.
6. " # ": The radiated frequency is out of the restricted band.

CHANNEL	TX Channel 48	DETECTOR FUNCTION	Peak (PK)
FREQUENCY RANGE	1GHz ~ 40GHz		Average (AV)

ANTENNA POLARITY & TEST DISTANCE: HORIZONTAL AT 3 M

NO.	FREQ. (MHz)	EMISSION LEVEL (dBuV/m)	LIMIT (dBuV/m)	MARGIN (dB)	ANTENNA HEIGHT (m)	TABLE ANGLE (Degree)	RAW VALUE (dBuV)	CORRECTION FACTOR (dB/m)
1	*5240.00	118.6 PK			1.67 H	348	79.7	38.9
2	*5240.00	107.9 AV			1.67 H	348	69.0	38.9
3	5440.00	58.1 PK	74.0	-15.9	1.69 H	341	52.4	5.7
4	5440.00	47.7 AV	54.0	-6.3	1.69 H	341	42.0	5.7
5	#10480.00	58.8 PK	74.0	-15.2	1.76 H	281	40.4	18.4
6	#10480.00	46.5 AV	54.0	-7.5	1.76 H	281	28.1	18.4

ANTENNA POLARITY & TEST DISTANCE: VERTICAL AT 3 M

NO.	FREQ. (MHz)	EMISSION LEVEL (dBuV/m)	LIMIT (dBuV/m)	MARGIN (dB)	ANTENNA HEIGHT (m)	TABLE ANGLE (Degree)	RAW VALUE (dBuV)	CORRECTION FACTOR (dB/m)
1	*5240.00	117.9 PK			1.72 V	345	79.0	38.9
2	*5240.00	107.9 AV			1.72 V	345	69.0	38.9
3	5440.00	57.8 PK	74.0	-16.2	1.79 V	348	52.1	5.7
4	5440.00	46.6 AV	54.0	-7.4	1.79 V	348	40.9	5.7
5	#10480.00	59.3 PK	74.0	-14.7	1.78 V	182	40.9	18.4
6	#10480.00	46.5 AV	54.0	-7.5	1.78 V	182	28.1	18.4

Remarks:

1. Emission Level(dBuV/m) = Raw Value(dBuV) + Correction Factor(dB/m)
2. Correction Factor(dB/m) = Antenna Factor(dB/m) + Cable Factor(dB) – Pre-Amplifier Factor(dB)
3. The other emission levels were very low against the limit.
4. Margin value = Emission Level – Limit value
5. " * ": Fundamental frequency.
6. " # ": The radiated frequency is out of the restricted band.

CHANNEL	TX Channel 149	DETECTOR FUNCTION	Peak (PK)
FREQUENCY RANGE	1GHz ~ 40GHz		Average (AV)

ANTENNA POLARITY & TEST DISTANCE: HORIZONTAL AT 3 M								
NO.	FREQ. (MHz)	EMISSION LEVEL (dBuV/m)	LIMIT (dBuV/m)	MARGIN (dB)	ANTENNA HEIGHT (m)	TABLE ANGLE (Degree)	RAW VALUE (dBuV)	CORRECTION FACTOR (dB/m)
1	*5745.00	123.0 PK			1.53 H	351	83.0	40.0
2	*5745.00	112.2 AV			1.53 H	351	72.2	40.0
3	11490.00	59.5 PK	74.0	-14.5	1.34 H	233	40.2	19.3
4	11490.00	47.1 AV	54.0	-6.9	1.34 H	233	27.8	19.3
ANTENNA POLARITY & TEST DISTANCE: VERTICAL AT 3 M								
NO.	FREQ. (MHz)	EMISSION LEVEL (dBuV/m)	LIMIT (dBuV/m)	MARGIN (dB)	ANTENNA HEIGHT (m)	TABLE ANGLE (Degree)	RAW VALUE (dBuV)	CORRECTION FACTOR (dB/m)
1	*5745.00	121.5 PK			1.52 V	348	81.5	40.0
2	*5745.00	111.1 AV			1.52 V	348	71.1	40.0
3	11490.00	60.6 PK	74.0	-13.4	1.67 V	270	41.3	19.3
4	11490.00	48.5 AV	54.0	-5.5	1.67 V	270	29.2	19.3

Remarks:

1. Emission Level(dBuV/m) = Raw Value(dBuV) + Correction Factor(dB/m)
2. Correction Factor(dB/m) = Antenna Factor(dB/m) + Cable Factor(dB) – Pre-Amplifier Factor(dB)
3. The other emission levels were very low against the limit.
4. Margin value = Emission Level – Limit value
5. " * ": Fundamental frequency.
6. " # ": The radiated frequency is out of the restricted band.

CHANNEL	TX Channel 157	DETECTOR FUNCTION	Peak (PK)
FREQUENCY RANGE	1GHz ~ 40GHz		Average (AV)

ANTENNA POLARITY & TEST DISTANCE: HORIZONTAL AT 3 M

NO.	FREQ. (MHz)	EMISSION LEVEL (dBuV/m)	LIMIT (dBuV/m)	MARGIN (dB)	ANTENNA HEIGHT (m)	TABLE ANGLE (Degree)	RAW VALUE (dBuV)	CORRECTION FACTOR (dB/m)
1	*5785.00	122.8 PK			1.60 H	348	82.7	40.1
2	*5785.00	112.2 AV			1.60 H	348	72.1	40.1
3	11570.00	60.2 PK	74.0	-13.8	1.36 H	232	41.0	19.2
4	11570.00	48.0 AV	54.0	-6.0	1.36 H	232	28.8	19.2

ANTENNA POLARITY & TEST DISTANCE: VERTICAL AT 3 M

NO.	FREQ. (MHz)	EMISSION LEVEL (dBuV/m)	LIMIT (dBuV/m)	MARGIN (dB)	ANTENNA HEIGHT (m)	TABLE ANGLE (Degree)	RAW VALUE (dBuV)	CORRECTION FACTOR (dB/m)
1	*5785.00	121.2 PK			1.64 V	347	81.1	40.1
2	*5785.00	111.0 AV			1.64 V	347	70.9	40.1
3	11570.00	62.9 PK	74.0	-11.1	1.76 V	264	43.7	19.2
4	11570.00	51.0 AV	54.0	-3.0	1.76 V	264	31.8	19.2

Remarks:

1. Emission Level(dBuV/m) = Raw Value(dBuV) + Correction Factor(dB/m)
2. Correction Factor(dB/m) = Antenna Factor(dB/m) + Cable Factor(dB) – Pre-Amplifier Factor(dB)
3. The other emission levels were very low against the limit.
4. Margin value = Emission Level – Limit value
5. " * " : Fundamental frequency.

CHANNEL	TX Channel 165	DETECTOR FUNCTION	Peak (PK)
FREQUENCY RANGE	1GHz ~ 40GHz		Average (AV)

ANTENNA POLARITY & TEST DISTANCE: HORIZONTAL AT 3 M								
NO.	FREQ. (MHz)	EMISSION LEVEL (dBuV/m)	LIMIT (dBuV/m)	MARGIN (dB)	ANTENNA HEIGHT (m)	TABLE ANGLE (Degree)	RAW VALUE (dBuV)	CORRECTION FACTOR (dB/m)
1	*5825.00	122.4 PK			1.57 H	348	82.3	40.1
2	*5825.00	111.7 AV			1.57 H	348	71.6	40.1
3	11650.00	61.1 PK	74.0	-12.9	1.52 H	232	41.8	19.3
4	11650.00	48.1 AV	54.0	-5.9	1.52 H	232	28.8	19.3
ANTENNA POLARITY & TEST DISTANCE: VERTICAL AT 3 M								
NO.	FREQ. (MHz)	EMISSION LEVEL (dBuV/m)	LIMIT (dBuV/m)	MARGIN (dB)	ANTENNA HEIGHT (m)	TABLE ANGLE (Degree)	RAW VALUE (dBuV)	CORRECTION FACTOR (dB/m)
1	*5825.00	120.0 PK			1.55 V	344	79.9	40.1
2	*5825.00	110.0 AV			1.55 V	344	69.9	40.1
3	11650.00	65.3 PK	74.0	-8.7	1.86 V	265	46.0	19.3
4	11650.00	52.9 AV	54.0	-1.1	1.86 V	265	33.6	19.3

Remarks:

1. Emission Level(dBuV/m) = Raw Value(dBuV) + Correction Factor(dB/m)
2. Correction Factor(dB/m) = Antenna Factor(dB/m) + Cable Factor(dB) – Pre-Amplifier Factor(dB)
3. The other emission levels were very low against the limit.
4. Margin value = Emission Level – Limit value
5. " * ": Fundamental frequency.
6. " # ": The radiated frequency is out of the restricted band.

802.11n (HT20)

CHANNEL	TX Channel 36	DETECTOR FUNCTION	Peak (PK) Average (AV)
FREQUENCY RANGE	1GHz ~ 40GHz		

ANTENNA POLARITY & TEST DISTANCE: HORIZONTAL AT 3 M

NO.	FREQ. (MHz)	EMISSION LEVEL (dBuV/m)	LIMIT (dBuV/m)	MARGIN (dB)	ANTENNA HEIGHT (m)	TABLE ANGLE (Degree)	RAW VALUE (dBuV)	CORRECTION FACTOR (dB/m)
1	5150.00	61.9 PK	74.0	-12.1	1.60 H	353	57.1	4.8
2	5150.00	48.9 AV	54.0	-5.1	1.60 H	353	44.1	4.8
3	*5180.00	118.9 PK			1.56 H	351	80.2	38.7
4	*5180.00	107.5 AV			1.56 H	351	68.8	38.7
5	#10360.00	58.2 PK	74.0	-15.8	1.59 H	264	40.6	17.6
6	#10360.00	45.9 AV	54.0	-8.1	1.59 H	264	28.3	17.6

ANTENNA POLARITY & TEST DISTANCE: VERTICAL AT 3 M

NO.	FREQ. (MHz)	EMISSION LEVEL (dBuV/m)	LIMIT (dBuV/m)	MARGIN (dB)	ANTENNA HEIGHT (m)	TABLE ANGLE (Degree)	RAW VALUE (dBuV)	CORRECTION FACTOR (dB/m)
1	5150.00	60.2 PK	74.0	-13.8	1.60 V	347	55.4	4.8
2	5150.00	48.3 AV	54.0	-5.7	1.60 V	347	43.5	4.8
3	*5180.00	118.2 PK			1.70 V	345	79.5	38.7
4	*5180.00	107.5 AV			1.70 V	345	68.8	38.7
5	#10360.00	59.4 PK	74.0	-14.6	1.53 V	188	41.8	17.6
6	#10360.00	46.0 AV	54.0	-8.0	1.53 V	188	28.4	17.6

Remarks:

1. Emission Level(dBuV/m) = Raw Value(dBuV) + Correction Factor(dB/m)
2. Correction Factor(dB/m) = Antenna Factor(dB/m) + Cable Factor(dB) – Pre-Amplifier Factor(dB)
3. The other emission levels were very low against the limit.
4. Margin value = Emission Level – Limit value
5. " * ": Fundamental frequency.
6. " # ": The radiated frequency is out of the restricted band.

CHANNEL	TX Channel 40	DETECTOR FUNCTION	Peak (PK)
FREQUENCY RANGE	1GHz ~ 40GHz		Average (AV)

ANTENNA POLARITY & TEST DISTANCE: HORIZONTAL AT 3 M

NO.	FREQ. (MHz)	EMISSION LEVEL (dBuV/m)	LIMIT (dBuV/m)	MARGIN (dB)	ANTENNA HEIGHT (m)	TABLE ANGLE (Degree)	RAW VALUE (dBuV)	CORRECTION FACTOR (dB/m)
1	*5200.00	116.7 PK			1.67 H	351	78.0	38.7
2	*5200.00	106.0 AV			1.67 H	351	67.3	38.7
3	#10400.00	58.2 PK	74.0	-15.8	1.67 H	281	40.6	17.6
4	#10400.00	45.8 AV	54.0	-8.2	1.67 H	281	28.2	17.6

ANTENNA POLARITY & TEST DISTANCE: VERTICAL AT 3 M

NO.	FREQ. (MHz)	EMISSION LEVEL (dBuV/m)	LIMIT (dBuV/m)	MARGIN (dB)	ANTENNA HEIGHT (m)	TABLE ANGLE (Degree)	RAW VALUE (dBuV)	CORRECTION FACTOR (dB/m)
1	*5200.00	117.7 PK			1.75 V	344	79.0	38.7
2	*5200.00	107.1 AV			1.75 V	344	68.4	38.7
3	#10400.00	58.4 PK	74.0	-15.6	1.62 V	171	40.8	17.6
4	#10400.00	46.0 AV	54.0	-8.0	1.62 V	171	28.4	17.6

Remarks:

1. Emission Level(dBuV/m) = Raw Value(dBuV) + Correction Factor(dB/m)
2. Correction Factor(dB/m) = Antenna Factor(dB/m) + Cable Factor(dB) – Pre-Amplifier Factor(dB)
3. The other emission levels were very low against the limit.
4. Margin value = Emission Level – Limit value
5. " * ": Fundamental frequency.
6. " # ": The radiated frequency is out of the restricted band.

CHANNEL	TX Channel 48	DETECTOR FUNCTION	Peak (PK)
FREQUENCY RANGE	1GHz ~ 40GHz		Average (AV)

ANTENNA POLARITY & TEST DISTANCE: HORIZONTAL AT 3 M

NO.	FREQ. (MHz)	EMISSION LEVEL (dBuV/m)	LIMIT (dBuV/m)	MARGIN (dB)	ANTENNA HEIGHT (m)	TABLE ANGLE (Degree)	RAW VALUE (dBuV)	CORRECTION FACTOR (dB/m)
1	*5240.00	118.1 PK			1.68 H	348	79.2	38.9
2	*5240.00	107.4 AV			1.68 H	348	68.5	38.9
3	5440.00	57.8 PK	74.0	-16.2	1.76 H	342	52.1	5.7
4	5440.00	47.5 AV	54.0	-6.5	1.76 H	342	41.8	5.7
5	#10480.00	58.5 PK	74.0	-15.5	1.82 H	271	40.1	18.4
6	#10480.00	46.3 AV	54.0	-7.7	1.82 H	271	27.9	18.4

ANTENNA POLARITY & TEST DISTANCE: VERTICAL AT 3 M

NO.	FREQ. (MHz)	EMISSION LEVEL (dBuV/m)	LIMIT (dBuV/m)	MARGIN (dB)	ANTENNA HEIGHT (m)	TABLE ANGLE (Degree)	RAW VALUE (dBuV)	CORRECTION FACTOR (dB/m)
1	*5240.00	118.6 PK			1.65 V	344	79.7	38.9
2	*5240.00	108.0 AV			1.65 V	344	69.1	38.9
3	5440.00	57.6 PK	74.0	-16.4	1.75 V	347	51.9	5.7
4	5440.00	47.0 AV	54.0	-7.0	1.75 V	347	41.3	5.7
5	#10480.00	58.5 PK	74.0	-15.5	1.72 V	191	40.1	18.4
6	#10480.00	45.7 AV	54.0	-8.3	1.72 V	191	27.3	18.4

Remarks:

1. Emission Level(dBuV/m) = Raw Value(dBuV) + Correction Factor(dB/m)
2. Correction Factor(dB/m) = Antenna Factor(dB/m) + Cable Factor(dB) – Pre-Amplifier Factor(dB)
3. The other emission levels were very low against the limit.
4. Margin value = Emission Level – Limit value
5. " * ": Fundamental frequency.
6. " # ": The radiated frequency is out of the restricted band.

CHANNEL	TX Channel 149	DETECTOR FUNCTION	Peak (PK)
FREQUENCY RANGE	1GHz ~ 40GHz		Average (AV)

ANTENNA POLARITY & TEST DISTANCE: HORIZONTAL AT 3 M								
NO.	FREQ. (MHz)	EMISSION LEVEL (dBuV/m)	LIMIT (dBuV/m)	MARGIN (dB)	ANTENNA HEIGHT (m)	TABLE ANGLE (Degree)	RAW VALUE (dBuV)	CORRECTION FACTOR (dB/m)
1	*5745.00	122.2 PK			1.63 H	350	82.2	40.0
2	*5745.00	111.7 AV			1.63 H	350	71.7	40.0
3	11490.00	60.0 PK	74.0	-14.0	1.55 H	254	40.7	19.3
4	11490.00	47.2 AV	54.0	-6.8	1.55 H	254	27.9	19.3
ANTENNA POLARITY & TEST DISTANCE: VERTICAL AT 3 M								
NO.	FREQ. (MHz)	EMISSION LEVEL (dBuV/m)	LIMIT (dBuV/m)	MARGIN (dB)	ANTENNA HEIGHT (m)	TABLE ANGLE (Degree)	RAW VALUE (dBuV)	CORRECTION FACTOR (dB/m)
1	*5745.00	122.6 PK			1.51 V	348	82.6	40.0
2	*5745.00	111.5 AV			1.51 V	348	71.5	40.0
3	11490.00	61.2 PK	74.0	-12.8	1.65 V	270	41.9	19.3
4	11490.00	48.3 AV	54.0	-5.7	1.65 V	270	29.0	19.3

Remarks:

1. Emission Level(dBuV/m) = Raw Value(dBuV) + Correction Factor(dB/m)
2. Correction Factor(dB/m) = Antenna Factor(dB/m) + Cable Factor(dB) – Pre-Amplifier Factor(dB)
3. The other emission levels were very low against the limit.
4. Margin value = Emission Level – Limit value
5. " * ": Fundamental frequency.
6. " # ": The radiated frequency is out of the restricted band.

CHANNEL	TX Channel 157	DETECTOR FUNCTION	Peak (PK)
FREQUENCY RANGE	1GHz ~ 40GHz		Average (AV)

ANTENNA POLARITY & TEST DISTANCE: HORIZONTAL AT 3 M								
NO.	FREQ. (MHz)	EMISSION LEVEL (dBuV/m)	LIMIT (dBuV/m)	MARGIN (dB)	ANTENNA HEIGHT (m)	TABLE ANGLE (Degree)	RAW VALUE (dBuV)	CORRECTION FACTOR (dB/m)
1	*5785.00	121.5 PK			1.63 H	350	81.4	40.1
2	*5785.00	111.2 AV			1.63 H	350	71.1	40.1
3	11570.00	60.7 PK	74.0	-13.3	1.73 H	232	41.5	19.2
4	11570.00	47.5 AV	54.0	-6.5	1.73 H	232	28.3	19.2
ANTENNA POLARITY & TEST DISTANCE: VERTICAL AT 3 M								
NO.	FREQ. (MHz)	EMISSION LEVEL (dBuV/m)	LIMIT (dBuV/m)	MARGIN (dB)	ANTENNA HEIGHT (m)	TABLE ANGLE (Degree)	RAW VALUE (dBuV)	CORRECTION FACTOR (dB/m)
1	*5785.00	121.7 PK			1.37 V	351	81.6	40.1
2	*5785.00	110.3 AV			1.37 V	351	70.2	40.1
3	11570.00	64.7 PK	74.0	-9.3	1.62 V	269	45.5	19.2
4	11570.00	50.1 AV	54.0	-3.9	1.62 V	269	30.9	19.2

Remarks:

1. Emission Level(dBuV/m) = Raw Value(dBuV) + Correction Factor(dB/m)
2. Correction Factor(dB/m) = Antenna Factor(dB/m) + Cable Factor(dB) – Pre-Amplifier Factor(dB)
3. The other emission levels were very low against the limit.
4. Margin value = Emission Level – Limit value
5. " * ": Fundamental frequency.

CHANNEL	TX Channel 165	DETECTOR FUNCTION	Peak (PK)
FREQUENCY RANGE	1GHz ~ 40GHz		Average (AV)

ANTENNA POLARITY & TEST DISTANCE: HORIZONTAL AT 3 M

NO.	FREQ. (MHz)	EMISSION LEVEL (dBuV/m)	LIMIT (dBuV/m)	MARGIN (dB)	ANTENNA HEIGHT (m)	TABLE ANGLE (Degree)	RAW VALUE (dBuV)	CORRECTION FACTOR (dB/m)
1	*5825.00	121.6 PK			1.93 H	346	81.5	40.1
2	*5825.00	111.1 AV			1.93 H	346	71.0	40.1
3	11650.00	60.0 PK	74.0	-14.0	1.60 H	240	40.7	19.3
4	11650.00	47.7 AV	54.0	-6.3	1.60 H	240	28.4	19.3

ANTENNA POLARITY & TEST DISTANCE: VERTICAL AT 3 M

NO.	FREQ. (MHz)	EMISSION LEVEL (dBuV/m)	LIMIT (dBuV/m)	MARGIN (dB)	ANTENNA HEIGHT (m)	TABLE ANGLE (Degree)	RAW VALUE (dBuV)	CORRECTION FACTOR (dB/m)
1	*5825.00	121.7 PK			1.69 V	344	81.6	40.1
2	*5825.00	110.5 AV			1.69 V	344	70.4	40.1
3	11650.00	66.0 PK	74.0	-8.0	1.70 V	264	46.7	19.3
4	11650.00	52.1 AV	54.0	-1.9	1.70 V	264	32.8	19.3

Remarks:

1. Emission Level(dBuV/m) = Raw Value(dBuV) + Correction Factor(dB/m)
2. Correction Factor(dB/m) = Antenna Factor(dB/m) + Cable Factor(dB) – Pre-Amplifier Factor(dB)
3. The other emission levels were very low against the limit.
4. Margin value = Emission Level – Limit value
5. " * ": Fundamental frequency.
6. " # ": The radiated frequency is out of the restricted band.

802.11n (HT40)

CHANNEL	TX Channel 38	DETECTOR FUNCTION	Peak (PK) Average (AV)
FREQUENCY RANGE	1GHz ~ 40GHz		

ANTENNA POLARITY & TEST DISTANCE: HORIZONTAL AT 3 M

NO.	FREQ. (MHz)	EMISSION LEVEL (dBuV/m)	LIMIT (dBuV/m)	MARGIN (dB)	ANTENNA HEIGHT (m)	TABLE ANGLE (Degree)	RAW VALUE (dBuV)	CORRECTION FACTOR (dB/m)
1	5150.00	66.2 PK	74.0	-7.8	1.59 H	349	61.4	4.8
2	5150.00	52.3 AV	54.0	-1.7	1.59 H	349	47.5	4.8
3	*5190.00	110.5 PK			1.63 H	349	71.8	38.7
4	*5190.00	101.0 AV			1.63 H	349	62.3	38.7
5	#10380.00	58.4 PK	74.0	-15.6	1.55 H	264	40.8	17.6
6	#10380.00	45.7 AV	54.0	-8.3	1.55 H	264	28.1	17.6

ANTENNA POLARITY & TEST DISTANCE: VERTICAL AT 3 M

NO.	FREQ. (MHz)	EMISSION LEVEL (dBuV/m)	LIMIT (dBuV/m)	MARGIN (dB)	ANTENNA HEIGHT (m)	TABLE ANGLE (Degree)	RAW VALUE (dBuV)	CORRECTION FACTOR (dB/m)
1	5150.00	64.7 PK	74.0	-9.3	1.51 V	342	59.9	4.8
2	5150.00	50.8 AV	54.0	-3.2	1.51 V	342	46.0	4.8
3	*5190.00	111.6 PK			1.51 V	342	72.9	38.7
4	*5190.00	102.4 AV			1.51 V	342	63.7	38.7
5	#10380.00	58.9 PK	74.0	-15.1	1.60 V	188	41.3	17.6
6	#10380.00	46.0 AV	54.0	-8.0	1.60 V	188	28.4	17.6

Remarks:

1. Emission Level(dBuV/m) = Raw Value(dBuV) + Correction Factor(dB/m)
2. Correction Factor(dB/m) = Antenna Factor(dB/m) + Cable Factor(dB) – Pre-Amplifier Factor(dB)
3. The other emission levels were very low against the limit.
4. Margin value = Emission Level – Limit value
5. " * ": Fundamental frequency.
6. " # ": The radiated frequency is out of the restricted band.

CHANNEL	TX Channel 46	DETECTOR FUNCTION	Peak (PK)
FREQUENCY RANGE	1GHz ~ 40GHz		Average (AV)

ANTENNA POLARITY & TEST DISTANCE: HORIZONTAL AT 3 M								
NO.	FREQ. (MHz)	EMISSION LEVEL (dBuV/m)	LIMIT (dBuV/m)	MARGIN (dB)	ANTENNA HEIGHT (m)	TABLE ANGLE (Degree)	RAW VALUE (dBuV)	CORRECTION FACTOR (dB/m)
1	*5230.00	114.6 PK			1.62 H	355	75.7	38.9
2	*5230.00	105.1 AV			1.62 H	355	66.2	38.9
3	5440.00	57.7 PK	74.0	-16.3	1.68 H	343	52.0	5.7
4	5440.00	47.9 AV	54.0	-6.1	1.68 H	343	42.2	5.7
5	#10460.00	59.0 PK	74.0	-15.0	1.61 H	259	40.8	18.2
6	#10460.00	46.1 AV	54.0	-7.9	1.61 H	259	27.9	18.2
ANTENNA POLARITY & TEST DISTANCE: VERTICAL AT 3 M								
NO.	FREQ. (MHz)	EMISSION LEVEL (dBuV/m)	LIMIT (dBuV/m)	MARGIN (dB)	ANTENNA HEIGHT (m)	TABLE ANGLE (Degree)	RAW VALUE (dBuV)	CORRECTION FACTOR (dB/m)
1	*5230.00	114.6 PK			1.62 V	345	75.7	38.9
2	*5230.00	105.5 AV			1.62 V	345	66.6	38.9
3	5440.00	57.9 PK	74.0	-16.1	1.70 V	340	52.2	5.7
4	5440.00	46.5 AV	54.0	-7.5	1.70 V	340	40.8	5.7
5	#10460.00	59.2 PK	74.0	-14.8	1.65 V	188	41.0	18.2
6	#10460.00	46.1 AV	54.0	-7.9	1.65 V	188	27.9	18.2

Remarks:

1. Emission Level(dBuV/m) = Raw Value(dBuV) + Correction Factor(dB/m)
2. Correction Factor(dB/m) = Antenna Factor(dB/m) + Cable Factor(dB) – Pre-Amplifier Factor(dB)
3. The other emission levels were very low against the limit.
4. Margin value = Emission Level – Limit value
5. " * ": Fundamental frequency.
6. " # ": The radiated frequency is out of the restricted band.

CHANNEL	TX Channel 151	DETECTOR FUNCTION	Peak (PK)
FREQUENCY RANGE	1GHz ~ 40GHz		Average (AV)

ANTENNA POLARITY & TEST DISTANCE: HORIZONTAL AT 3 M								
NO.	FREQ. (MHz)	EMISSION LEVEL (dBuV/m)	LIMIT (dBuV/m)	MARGIN (dB)	ANTENNA HEIGHT (m)	TABLE ANGLE (Degree)	RAW VALUE (dBuV)	CORRECTION FACTOR (dB/m)
1	*5755.00	119.4 PK			1.77 H	349	79.4	40.0
2	*5755.00	109.5 AV			1.77 H	349	69.5	40.0
3	11510.00	59.4 PK	74.0	-14.6	1.70 H	239	40.1	19.3
4	11510.00	47.0 AV	54.0	-7.0	1.70 H	239	27.7	19.3
ANTENNA POLARITY & TEST DISTANCE: VERTICAL AT 3 M								
NO.	FREQ. (MHz)	EMISSION LEVEL (dBuV/m)	LIMIT (dBuV/m)	MARGIN (dB)	ANTENNA HEIGHT (m)	TABLE ANGLE (Degree)	RAW VALUE (dBuV)	CORRECTION FACTOR (dB/m)
1	*5755.00	117.5 PK			1.62 V	350	77.5	40.0
2	*5755.00	107.8 AV			1.62 V	350	67.8	40.0
3	11510.00	59.6 PK	74.0	-14.4	1.51 V	270	40.3	19.3
4	11510.00	47.5 AV	54.0	-6.5	1.51 V	270	28.2	19.3

Remarks:

1. Emission Level(dBuV/m) = Raw Value(dBuV) + Correction Factor(dB/m)
2. Correction Factor(dB/m) = Antenna Factor(dB/m) + Cable Factor(dB) – Pre-Amplifier Factor(dB)
3. The other emission levels were very low against the limit.
4. Margin value = Emission Level – Limit value
5. " * ": Fundamental frequency.
6. " # ": The radiated frequency is out of the restricted band.

CHANNEL	TX Channel 159	DETECTOR FUNCTION	Peak (PK)
FREQUENCY RANGE	1GHz ~ 40GHz		Average (AV)

ANTENNA POLARITY & TEST DISTANCE: HORIZONTAL AT 3 M								
NO.	FREQ. (MHz)	EMISSION LEVEL (dBuV/m)	LIMIT (dBuV/m)	MARGIN (dB)	ANTENNA HEIGHT (m)	TABLE ANGLE (Degree)	RAW VALUE (dBuV)	CORRECTION FACTOR (dB/m)
1	*5795.00	119.6 PK			1.74 H	350	79.5	40.1
2	*5795.00	109.6 AV			1.74 H	350	69.5	40.1
3	11590.00	59.2 PK	74.0	-14.8	1.82 H	223	40.0	19.2
4	11590.00	47.0 AV	54.0	-7.0	1.82 H	223	27.8	19.2
ANTENNA POLARITY & TEST DISTANCE: VERTICAL AT 3 M								
NO.	FREQ. (MHz)	EMISSION LEVEL (dBuV/m)	LIMIT (dBuV/m)	MARGIN (dB)	ANTENNA HEIGHT (m)	TABLE ANGLE (Degree)	RAW VALUE (dBuV)	CORRECTION FACTOR (dB/m)
1	*5795.00	118.2 PK			1.72 V	345	78.1	40.1
2	*5795.00	107.9 AV			1.72 V	345	67.8	40.1
3	11590.00	62.4 PK	74.0	-11.6	1.57 V	266	43.2	19.2
4	11590.00	49.9 AV	54.0	-4.1	1.57 V	266	30.7	19.2

Remarks:

1. Emission Level(dBuV/m) = Raw Value(dBuV) + Correction Factor(dB/m)
2. Correction Factor(dB/m) = Antenna Factor(dB/m) + Cable Factor(dB) – Pre-Amplifier Factor(dB)
3. The other emission levels were very low against the limit.
4. Margin value = Emission Level – Limit value
5. " * ": Fundamental frequency.
6. " # ": The radiated frequency is out of the restricted band.

802.11ac (VHT80)

CHANNEL	TX Channel 42	DETECTOR FUNCTION	Peak (PK) Average (AV)
FREQUENCY RANGE	1GHz ~ 40GHz		

ANTENNA POLARITY & TEST DISTANCE: HORIZONTAL AT 3 M								
NO.	FREQ. (MHz)	EMISSION LEVEL (dBuV/m)	LIMIT (dBuV/m)	MARGIN (dB)	ANTENNA HEIGHT (m)	TABLE ANGLE (Degree)	RAW VALUE (dBuV)	CORRECTION FACTOR (dB/m)
1	5150.00	64.7 PK	74.0	-9.3	1.58 H	348	59.9	4.8
2	5150.00	52.2 AV	54.0	-1.8	1.58 H	348	47.4	4.8
3	*5210.00	107.2 PK			1.52 H	348	68.5	38.7
4	*5210.00	97.8 AV			1.52 H	348	59.1	38.7
5	5440.00	59.4 PK	74.0	-14.6	1.56 H	342	53.7	5.7
6	5440.00	47.6 AV	54.0	-6.4	1.56 H	342	41.9	5.7
7	#10420.00	58.3 PK	74.0	-15.7	1.61 H	286	40.5	17.8
8	#10420.00	46.2 AV	54.0	-7.8	1.61 H	286	28.4	17.8

ANTENNA POLARITY & TEST DISTANCE: VERTICAL AT 3 M								
NO.	FREQ. (MHz)	EMISSION LEVEL (dBuV/m)	LIMIT (dBuV/m)	MARGIN (dB)	ANTENNA HEIGHT (m)	TABLE ANGLE (Degree)	RAW VALUE (dBuV)	CORRECTION FACTOR (dB/m)
1	5150.00	65.1 PK	74.0	-8.9	1.73 V	343	60.3	4.8
2	5150.00	52.3 AV	54.0	-1.7	1.73 V	343	47.5	4.8
3	*5210.00	107.6 PK			1.38 V	346	68.9	38.7
4	*5210.00	97.6 AV			1.38 V	346	58.9	38.7
5	5440.00	60.0 PK	74.0	-14.0	1.55 V	346	54.3	5.7
6	5440.00	47.6 AV	54.0	-6.4	1.55 V	346	41.9	5.7
7	#10420.00	58.9 PK	74.0	-15.1	1.58 V	167	41.1	17.8
8	#10420.00	46.2 AV	54.0	-7.8	1.58 V	167	28.4	17.8

Remarks:

1. Emission Level(dBuV/m) = Raw Value(dBuV) + Correction Factor(dB/m)
2. Correction Factor(dB/m) = Antenna Factor(dB/m) + Cable Factor(dB) – Pre-Amplifier Factor(dB)
3. The other emission levels were very low against the limit.
4. Margin value = Emission Level – Limit value
5. " * ": Fundamental frequency.
6. " # ": The radiated frequency is out of the restricted band.

CHANNEL	TX Channel 155	DETECTOR FUNCTION	Peak (PK)
FREQUENCY RANGE	1GHz ~ 40GHz		Average (AV)

ANTENNA POLARITY & TEST DISTANCE: HORIZONTAL AT 3 M								
NO.	FREQ. (MHz)	EMISSION LEVEL (dBuV/m)	LIMIT (dBuV/m)	MARGIN (dB)	ANTENNA HEIGHT (m)	TABLE ANGLE (Degree)	RAW VALUE (dBuV)	CORRECTION FACTOR (dB/m)
1	#5643.20	68.4 PK	74.0	-5.6	1.83 H	349	62.3	6.1
2	#5643.20	52.4 AV	54.0	-1.6	1.83 H	349	46.3	6.1
3	*5775.00	114.4 PK			1.83 H	350	74.4	40.0
4	*5775.00	104.1 AV			1.83 H	350	64.1	40.0
5	11550.00	59.4 PK	74.0	-14.6	1.72 H	261	40.2	19.2
6	11550.00	46.9 AV	54.0	-7.1	1.72 H	261	27.7	19.2

ANTENNA POLARITY & TEST DISTANCE: VERTICAL AT 3 M								
NO.	FREQ. (MHz)	EMISSION LEVEL (dBuV/m)	LIMIT (dBuV/m)	MARGIN (dB)	ANTENNA HEIGHT (m)	TABLE ANGLE (Degree)	RAW VALUE (dBuV)	CORRECTION FACTOR (dB/m)
1	#5643.20	64.7 PK	74.0	-9.3	1.73 V	344	58.6	6.1
2	#5643.20	50.2 AV	54.0	-3.8	1.73 V	344	44.1	6.1
3	*5775.00	112.0 PK			1.76 V	346	72.0	40.0
4	*5775.00	102.0 AV			1.76 V	346	62.0	40.0
5	11550.00	59.0 PK	74.0	-15.0	1.66 V	235	39.8	19.2
6	11550.00	47.3 AV	54.0	-6.7	1.66 V	235	28.1	19.2

Remarks:

1. Emission Level(dBuV/m) = Raw Value(dBuV) + Correction Factor(dB/m)
2. Correction Factor(dB/m) = Antenna Factor(dB/m) + Cable Factor(dB) – Pre-Amplifier Factor(dB)
3. The other emission levels were very low against the limit.
4. Margin value = Emission Level – Limit value
5. " * ": Fundamental frequency.
6. " # ": The radiated frequency is out of the restricted band.

Below 1GHz Worst-Case Data:

802.11a

CHANNEL	TX Channel 149	DETECTOR FUNCTION	Quasi-Peak (QP)
FREQUENCY RANGE	9kHz ~ 1GHz		

ANTENNA POLARITY & TEST DISTANCE: HORIZONTAL AT 3 M								
NO.	FREQ. (MHz)	EMISSION LEVEL (dBuV/m)	LIMIT (dBuV/m)	MARGIN (dB)	ANTENNA HEIGHT (m)	TABLE ANGLE (Degree)	RAW VALUE (dBuV)	CORRECTION FACTOR (dB/m)
1	96.01	34.2 QP	43.5	-9.3	2.00 H	278	53.6	-19.4
2	125.17	31.7 QP	43.5	-11.8	2.00 H	240	47.8	-16.1
3	249.60	34.2 QP	46.0	-11.8	1.00 H	4	48.2	-14.0
4	374.04	39.4 QP	46.0	-6.6	1.00 H	335	49.9	-10.5
5	624.85	32.2 QP	46.0	-13.8	2.00 H	216	36.9	-4.7
6	875.67	40.9 QP	46.0	-5.1	2.00 H	244	41.0	-0.1

ANTENNA POLARITY & TEST DISTANCE: VERTICAL AT 3 M								
NO.	FREQ. (MHz)	EMISSION LEVEL (dBuV/m)	LIMIT (dBuV/m)	MARGIN (dB)	ANTENNA HEIGHT (m)	TABLE ANGLE (Degree)	RAW VALUE (dBuV)	CORRECTION FACTOR (dB/m)
1	36.54	37.1 QP	40.0	-2.9	1.45 V	12	52.6	-15.5
2	74.62	36.6 QP	40.0	-3.4	2.00 V	181	54.0	-17.4
3	249.60	33.2 QP	46.0	-12.8	1.00 V	123	47.2	-14.0
4	374.04	37.5 QP	46.0	-8.5	1.00 V	278	48.0	-10.5
5	624.85	35.5 QP	46.0	-10.5	1.50 V	285	40.2	-4.7
6	875.67	41.0 QP	46.0	-5.0	1.00 V	301	41.1	-0.1

Remarks:

1. Emission Level(dBuV/m) = Raw Value(dBuV) + Correction Factor(dB/m)
2. Correction Factor(dB/m) = Antenna Factor(dB/m) + Cable Factor(dB) – Pre-Amplifier Factor(dB)
3. The other emission levels were very low against the limit.
4. Margin value = Emission Level – Limit value

Test Mode F

Above 1GHz worst-Case Data:

802.11a

CHANNEL	TX Channel 36	DETECTOR FUNCTION	Peak (PK)
FREQUENCY RANGE	1GHz ~ 40GHz		Average (AV)

ANTENNA POLARITY & TEST DISTANCE: HORIZONTAL AT 3 M

NO.	FREQ. (MHz)	EMISSION LEVEL (dBuV/m)	LIMIT (dBuV/m)	MARGIN (dB)	ANTENNA HEIGHT (m)	TABLE ANGLE (Degree)	RAW VALUE (dBuV)	CORRECTION FACTOR (dB/m)
1	5150.00	67.8 PK	74.0	-6.2	1.22 H	353	63.0	4.8
2	5150.00	52.6 AV	54.0	-1.4	1.22 H	353	47.8	4.8
3	*5180.00	109.2 PK			1.37 H	351	70.5	38.7
4	*5180.00	99.0 AV			1.37 H	351	60.3	38.7
5	#10360.00	60.2 PK	74.0	-13.8	1.61 H	19	42.6	17.6
6	#10360.00	48.2 AV	54.0	-5.8	1.61 H	19	30.6	17.6

ANTENNA POLARITY & TEST DISTANCE: VERTICAL AT 3 M

NO.	FREQ. (MHz)	EMISSION LEVEL (dBuV/m)	LIMIT (dBuV/m)	MARGIN (dB)	ANTENNA HEIGHT (m)	TABLE ANGLE (Degree)	RAW VALUE (dBuV)	CORRECTION FACTOR (dB/m)
1	5150.00	65.9 PK	74.0	-8.1	2.80 V	17	61.1	4.8
2	5150.00	51.1 AV	54.0	-2.9	2.80 V	17	46.3	4.8
3	*5180.00	109.6 PK			2.75 V	11	70.9	38.7
4	*5180.00	98.6 AV			2.75 V	11	59.9	38.7
5	#10360.00	62.9 PK	74.0	-11.1	2.33 V	324	45.3	17.6
6	#10360.00	50.1 AV	54.0	-3.9	2.33 V	324	32.5	17.6

Remarks:

1. Emission Level(dBuV/m) = Raw Value(dBuV) + Correction Factor(dB/m)
2. Correction Factor(dB/m) = Antenna Factor(dB/m) + Cable Factor(dB) – Pre-Amplifier Factor(dB)
3. The other emission levels were very low against the limit.
4. Margin value = Emission Level – Limit value
5. " * ": Fundamental frequency.
6. " # ": The radiated frequency is out of the restricted band.

CHANNEL	TX Channel 40	DETECTOR FUNCTION	Peak (PK)
FREQUENCY RANGE	1GHz ~ 40GHz		Average (AV)

ANTENNA POLARITY & TEST DISTANCE: HORIZONTAL AT 3 M								
NO.	FREQ. (MHz)	EMISSION LEVEL (dBuV/m)	LIMIT (dBuV/m)	MARGIN (dB)	ANTENNA HEIGHT (m)	TABLE ANGLE (Degree)	RAW VALUE (dBuV)	CORRECTION FACTOR (dB/m)
1	*5200.00	110.6 PK			2.58 H	352	71.9	38.7
2	*5200.00	99.6 AV			2.58 H	352	60.9	38.7
3	#10400.00	62.5 PK	74.0	-11.5	1.58 H	18	44.9	17.6
4	#10400.00	49.9 AV	54.0	-4.1	1.58 H	18	32.3	17.6
ANTENNA POLARITY & TEST DISTANCE: VERTICAL AT 3 M								
NO.	FREQ. (MHz)	EMISSION LEVEL (dBuV/m)	LIMIT (dBuV/m)	MARGIN (dB)	ANTENNA HEIGHT (m)	TABLE ANGLE (Degree)	RAW VALUE (dBuV)	CORRECTION FACTOR (dB/m)
1	*5200.00	111.0 PK			2.76 V	13	72.3	38.7
2	*5200.00	100.4 AV			2.76 V	13	61.7	38.7
3	#10400.00	65.1 PK	74.0	-8.9	1.61 V	325	47.5	17.6
4	#10400.00	52.5 AV	54.0	-1.5	1.61 V	325	34.9	17.6

Remarks:

1. Emission Level(dBuV/m) = Raw Value(dBuV) + Correction Factor(dB/m)
2. Correction Factor(dB/m) = Antenna Factor(dB/m) + Cable Factor(dB) – Pre-Amplifier Factor(dB)
3. The other emission levels were very low against the limit.
4. Margin value = Emission Level – Limit value
5. " * ": Fundamental frequency.
6. " # ": The radiated frequency is out of the restricted band.

CHANNEL	TX Channel 48	DETECTOR FUNCTION	Peak (PK)
FREQUENCY RANGE	1GHz ~ 40GHz		Average (AV)

ANTENNA POLARITY & TEST DISTANCE: HORIZONTAL AT 3 M								
NO.	FREQ. (MHz)	EMISSION LEVEL (dBuV/m)	LIMIT (dBuV/m)	MARGIN (dB)	ANTENNA HEIGHT (m)	TABLE ANGLE (Degree)	RAW VALUE (dBuV)	CORRECTION FACTOR (dB/m)
1	*5240.00	111.7 PK			2.53 H	351	72.8	38.9
2	*5240.00	101.1 AV			2.53 H	351	62.2	38.9
3	5350.00	55.2 PK	74.0	-18.8	2.41 H	336	49.7	5.5
4	5350.00	43.5 AV	54.0	-10.5	2.41 H	336	38.0	5.5
5	#10480.00	61.4 PK	74.0	-12.6	1.89 H	6	43.0	18.4
6	#10480.00	49.3 AV	54.0	-4.7	1.89 H	6	30.9	18.4

ANTENNA POLARITY & TEST DISTANCE: VERTICAL AT 3 M								
NO.	FREQ. (MHz)	EMISSION LEVEL (dBuV/m)	LIMIT (dBuV/m)	MARGIN (dB)	ANTENNA HEIGHT (m)	TABLE ANGLE (Degree)	RAW VALUE (dBuV)	CORRECTION FACTOR (dB/m)
1	*5240.00	111.0 PK			2.83 V	11	72.1	38.9
2	*5240.00	100.5 AV			2.83 V	11	61.6	38.9
3	5350.00	55.2 PK	74.0	-18.8	2.62 V	354	49.7	5.5
4	5350.00	43.3 AV	54.0	-10.7	2.62 V	354	37.8	5.5
5	#10480.00	64.9 PK	74.0	-9.1	2.50 V	339	46.5	18.4
6	#10480.00	52.2 AV	54.0	-1.8	2.50 V	339	33.8	18.4

Remarks:

1. Emission Level(dBuV/m) = Raw Value(dBuV) + Correction Factor(dB/m)
2. Correction Factor(dB/m) = Antenna Factor(dB/m) + Cable Factor(dB) – Pre-Amplifier Factor(dB)
3. The other emission levels were very low against the limit.
4. Margin value = Emission Level – Limit value
5. " * ": Fundamental frequency.
6. " # ": The radiated frequency is out of the restricted band.

CHANNEL	TX Channel 149	DETECTOR FUNCTION	Peak (PK)
FREQUENCY RANGE	1GHz ~ 40GHz		Average (AV)

ANTENNA POLARITY & TEST DISTANCE: HORIZONTAL AT 3 M								
NO.	FREQ. (MHz)	EMISSION LEVEL (dBuV/m)	LIMIT (dBuV/m)	MARGIN (dB)	ANTENNA HEIGHT (m)	TABLE ANGLE (Degree)	RAW VALUE (dBuV)	CORRECTION FACTOR (dB/m)
1	*5745.00	111.5 PK			1.32 H	336	71.5	40.0
2	*5745.00	101.2 AV			1.32 H	336	61.2	40.0
3	11490.00	60.3 PK	74.0	-13.7	1.63 H	75	41.0	19.3
4	11490.00	47.4 AV	54.0	-6.6	1.63 H	75	28.1	19.3
ANTENNA POLARITY & TEST DISTANCE: VERTICAL AT 3 M								
NO.	FREQ. (MHz)	EMISSION LEVEL (dBuV/m)	LIMIT (dBuV/m)	MARGIN (dB)	ANTENNA HEIGHT (m)	TABLE ANGLE (Degree)	RAW VALUE (dBuV)	CORRECTION FACTOR (dB/m)
1	*5745.00	109.9 PK			2.78 V	17	69.9	40.0
2	*5745.00	99.5 AV			2.78 V	17	59.5	40.0
3	11490.00	60.2 PK	74.0	-13.8	1.74 V	292	40.9	19.3
4	11490.00	47.6 AV	54.0	-6.4	1.74 V	292	28.3	19.3

Remarks:

1. Emission Level(dBuV/m) = Raw Value(dBuV) + Correction Factor(dB/m)
2. Correction Factor(dB/m) = Antenna Factor(dB/m) + Cable Factor(dB) – Pre-Amplifier Factor(dB)
3. The other emission levels were very low against the limit.
4. Margin value = Emission Level – Limit value
5. " * ": Fundamental frequency.
6. " # ": The radiated frequency is out of the restricted band.

CHANNEL	TX Channel 157	DETECTOR FUNCTION	Peak (PK)
FREQUENCY RANGE	1GHz ~ 40GHz		Average (AV)

ANTENNA POLARITY & TEST DISTANCE: HORIZONTAL AT 3 M								
NO.	FREQ. (MHz)	EMISSION LEVEL (dBuV/m)	LIMIT (dBuV/m)	MARGIN (dB)	ANTENNA HEIGHT (m)	TABLE ANGLE (Degree)	RAW VALUE (dBuV)	CORRECTION FACTOR (dB/m)
1	*5785.00	111.2 PK			1.68 H	337	71.1	40.1
2	*5785.00	100.7 AV			1.68 H	337	60.6	40.1
3	11570.00	60.2 PK	74.0	-13.8	2.58 H	54	41.0	19.2
4	11570.00	47.7 AV	54.0	-6.3	2.58 H	54	28.5	19.2
ANTENNA POLARITY & TEST DISTANCE: VERTICAL AT 3 M								
NO.	FREQ. (MHz)	EMISSION LEVEL (dBuV/m)	LIMIT (dBuV/m)	MARGIN (dB)	ANTENNA HEIGHT (m)	TABLE ANGLE (Degree)	RAW VALUE (dBuV)	CORRECTION FACTOR (dB/m)
1	*5785.00	110.9 PK			2.77 V	19	70.8	40.1
2	*5785.00	100.3 AV			2.77 V	19	60.2	40.1
3	11570.00	60.2 PK	74.0	-13.8	2.03 V	282	41.0	19.2
4	11570.00	47.7 AV	54.0	-6.3	2.03 V	282	28.5	19.2

Remarks:

1. Emission Level(dBuV/m) = Raw Value(dBuV) + Correction Factor(dB/m)
2. Correction Factor(dB/m) = Antenna Factor(dB/m) + Cable Factor(dB) – Pre-Amplifier Factor(dB)
3. The other emission levels were very low against the limit.
4. Margin value = Emission Level – Limit value
5. " * ": Fundamental frequency.

CHANNEL	TX Channel 165	DETECTOR FUNCTION	Peak (PK)
FREQUENCY RANGE	1GHz ~ 40GHz		Average (AV)

ANTENNA POLARITY & TEST DISTANCE: HORIZONTAL AT 3 M								
NO.	FREQ. (MHz)	EMISSION LEVEL (dBuV/m)	LIMIT (dBuV/m)	MARGIN (dB)	ANTENNA HEIGHT (m)	TABLE ANGLE (Degree)	RAW VALUE (dBuV)	CORRECTION FACTOR (dB/m)
1	*5825.00	110.3 PK			1.51 H	340	70.2	40.1
2	*5825.00	99.5 AV			1.51 H	340	59.4	40.1
3	11650.00	60.0 PK	74.0	-14.0	1.64 H	252	40.7	19.3
4	11650.00	47.6 AV	54.0	-6.4	1.64 H	252	28.3	19.3
ANTENNA POLARITY & TEST DISTANCE: VERTICAL AT 3 M								
NO.	FREQ. (MHz)	EMISSION LEVEL (dBuV/m)	LIMIT (dBuV/m)	MARGIN (dB)	ANTENNA HEIGHT (m)	TABLE ANGLE (Degree)	RAW VALUE (dBuV)	CORRECTION FACTOR (dB/m)
1	*5825.00	110.2 PK			2.83 V	24	70.1	40.1
2	*5825.00	99.8 AV			2.83 V	24	59.7	40.1
3	11650.00	60.5 PK	74.0	-13.5	1.75 V	233	41.2	19.3
4	11650.00	47.6 AV	54.0	-6.4	1.75 V	233	28.3	19.3

Remarks:

1. Emission Level(dBuV/m) = Raw Value(dBuV) + Correction Factor(dB/m)
2. Correction Factor(dB/m) = Antenna Factor(dB/m) + Cable Factor(dB) – Pre-Amplifier Factor(dB)
3. The other emission levels were very low against the limit.
4. Margin value = Emission Level – Limit value
5. " * ": Fundamental frequency.
6. " # ": The radiated frequency is out of the restricted band.

802.11n (HT20)

CHANNEL	TX Channel 36	DETECTOR FUNCTION	Peak (PK) Average (AV)
FREQUENCY RANGE	1GHz ~ 40GHz		

ANTENNA POLARITY & TEST DISTANCE: HORIZONTAL AT 3 M

NO.	FREQ. (MHz)	EMISSION LEVEL (dBuV/m)	LIMIT (dBuV/m)	MARGIN (dB)	ANTENNA HEIGHT (m)	TABLE ANGLE (Degree)	RAW VALUE (dBuV)	CORRECTION FACTOR (dB/m)
1	5150.00	67.2 PK	74.0	-6.8	1.16 H	349	62.4	4.8
2	5150.00	52.4 AV	54.0	-1.6	1.16 H	349	47.6	4.8
3	*5180.00	108.0 PK			2.88 H	352	69.3	38.7
4	*5180.00	97.8 AV			2.88 H	352	59.1	38.7
5	#10360.00	59.7 PK	74.0	-14.3	1.33 H	311	42.1	17.6
6	#10360.00	47.6 AV	54.0	-6.4	1.33 H	311	30.0	17.6

ANTENNA POLARITY & TEST DISTANCE: VERTICAL AT 3 M

NO.	FREQ. (MHz)	EMISSION LEVEL (dBuV/m)	LIMIT (dBuV/m)	MARGIN (dB)	ANTENNA HEIGHT (m)	TABLE ANGLE (Degree)	RAW VALUE (dBuV)	CORRECTION FACTOR (dB/m)
1	5150.00	66.2 PK	74.0	-7.8	2.92 V	15	61.4	4.8
2	5150.00	51.0 AV	54.0	-3.0	2.92 V	15	46.2	4.8
3	*5180.00	108.2 PK			2.90 V	16	69.5	38.7
4	*5180.00	97.7 AV			2.90 V	16	59.0	38.7
5	#10360.00	62.4 PK	74.0	-11.6	2.35 V	327	44.8	17.6
6	#10360.00	48.8 AV	54.0	-5.2	2.35 V	327	31.2	17.6

Remarks:

1. Emission Level(dBuV/m) = Raw Value(dBuV) + Correction Factor(dB/m)
2. Correction Factor(dB/m) = Antenna Factor(dB/m) + Cable Factor(dB) – Pre-Amplifier Factor(dB)
3. The other emission levels were very low against the limit.
4. Margin value = Emission Level – Limit value
5. " * ": Fundamental frequency.
6. " # ": The radiated frequency is out of the restricted band.

CHANNEL	TX Channel 40	DETECTOR FUNCTION	Peak (PK)
FREQUENCY RANGE	1GHz ~ 40GHz		Average (AV)

ANTENNA POLARITY & TEST DISTANCE: HORIZONTAL AT 3 M

NO.	FREQ. (MHz)	EMISSION LEVEL (dBuV/m)	LIMIT (dBuV/m)	MARGIN (dB)	ANTENNA HEIGHT (m)	TABLE ANGLE (Degree)	RAW VALUE (dBuV)	CORRECTION FACTOR (dB/m)
1	*5200.00	110.2 PK			2.57 H	352	71.5	38.7
2	*5200.00	99.7 AV			2.57 H	352	61.0	38.7
3	#10400.00	62.3 PK	74.0	-11.7	1.50 H	19	44.7	17.6
4	#10400.00	49.4 AV	54.0	-4.6	1.50 H	19	31.8	17.6

ANTENNA POLARITY & TEST DISTANCE: VERTICAL AT 3 M

NO.	FREQ. (MHz)	EMISSION LEVEL (dBuV/m)	LIMIT (dBuV/m)	MARGIN (dB)	ANTENNA HEIGHT (m)	TABLE ANGLE (Degree)	RAW VALUE (dBuV)	CORRECTION FACTOR (dB/m)
1	*5200.00	109.6 PK			2.77 V	15	70.9	38.7
2	*5200.00	99.2 AV			2.77 V	15	60.5	38.7
3	#10400.00	64.5 PK	74.0	-9.5	1.74 V	325	46.9	17.6
4	#10400.00	51.3 AV	54.0	-2.7	1.74 V	325	33.7	17.6

Remarks:

1. Emission Level(dBuV/m) = Raw Value(dBuV) + Correction Factor(dB/m)
2. Correction Factor(dB/m) = Antenna Factor(dB/m) + Cable Factor(dB) – Pre-Amplifier Factor(dB)
3. The other emission levels were very low against the limit.
4. Margin value = Emission Level – Limit value
5. " * ": Fundamental frequency.
6. " # ": The radiated frequency is out of the restricted band.

CHANNEL	TX Channel 48	DETECTOR FUNCTION	Peak (PK)
FREQUENCY RANGE	1GHz ~ 40GHz		Average (AV)

ANTENNA POLARITY & TEST DISTANCE: HORIZONTAL AT 3 M								
NO.	FREQ. (MHz)	EMISSION LEVEL (dBuV/m)	LIMIT (dBuV/m)	MARGIN (dB)	ANTENNA HEIGHT (m)	TABLE ANGLE (Degree)	RAW VALUE (dBuV)	CORRECTION FACTOR (dB/m)
1	*5240.00	110.2 PK			2.31 H	353	71.3	38.9
2	*5240.00	99.7 AV			2.31 H	353	60.8	38.9
3	5350.00	55.9 PK	74.0	-18.1	2.20 H	344	50.4	5.5
4	5350.00	43.4 AV	54.0	-10.6	2.20 H	344	37.9	5.5
5	#10480.00	61.6 PK	74.0	-12.4	1.63 H	15	43.2	18.4
6	#10480.00	48.9 AV	54.0	-5.1	1.63 H	15	30.5	18.4

ANTENNA POLARITY & TEST DISTANCE: VERTICAL AT 3 M								
NO.	FREQ. (MHz)	EMISSION LEVEL (dBuV/m)	LIMIT (dBuV/m)	MARGIN (dB)	ANTENNA HEIGHT (m)	TABLE ANGLE (Degree)	RAW VALUE (dBuV)	CORRECTION FACTOR (dB/m)
1	*5240.00	110.8 PK			2.83 V	13	71.9	38.9
2	*5240.00	100.2 AV			2.83 V	13	61.3	38.9
3	5350.00	56.7 PK	74.0	-17.3	2.68 V	353	51.2	5.5
4	5350.00	42.9 AV	54.0	-11.1	2.68 V	353	37.4	5.5
5	#10480.00	64.9 PK	74.0	-9.1	2.21 V	323	46.5	18.4
6	#10480.00	50.7 AV	54.0	-3.3	2.21 V	323	32.3	18.4

Remarks:

1. Emission Level(dBuV/m) = Raw Value(dBuV) + Correction Factor(dB/m)
2. Correction Factor(dB/m) = Antenna Factor(dB/m) + Cable Factor(dB) – Pre-Amplifier Factor(dB)
3. The other emission levels were very low against the limit.
4. Margin value = Emission Level – Limit value
5. " * ": Fundamental frequency.
6. " # ": The radiated frequency is out of the restricted band.

CHANNEL	TX Channel 149	DETECTOR FUNCTION	Peak (PK)
FREQUENCY RANGE	1GHz ~ 40GHz		Average (AV)

ANTENNA POLARITY & TEST DISTANCE: HORIZONTAL AT 3 M								
NO.	FREQ. (MHz)	EMISSION LEVEL (dBuV/m)	LIMIT (dBuV/m)	MARGIN (dB)	ANTENNA HEIGHT (m)	TABLE ANGLE (Degree)	RAW VALUE (dBuV)	CORRECTION FACTOR (dB/m)
1	*5745.00	111.4 PK			2.22 H	352	71.4	40.0
2	*5745.00	101.1 AV			2.22 H	352	61.1	40.0
3	11490.00	59.5 PK	74.0	-14.5	1.86 H	264	40.2	19.3
4	11490.00	47.3 AV	54.0	-6.7	1.86 H	264	28.0	19.3
ANTENNA POLARITY & TEST DISTANCE: VERTICAL AT 3 M								
NO.	FREQ. (MHz)	EMISSION LEVEL (dBuV/m)	LIMIT (dBuV/m)	MARGIN (dB)	ANTENNA HEIGHT (m)	TABLE ANGLE (Degree)	RAW VALUE (dBuV)	CORRECTION FACTOR (dB/m)
1	*5745.00	109.2 PK			2.75 V	13	69.2	40.0
2	*5745.00	98.7 AV			2.75 V	13	58.7	40.0
3	11490.00	60.0 PK	74.0	-14.0	2.31 V	282	40.7	19.3
4	11490.00	47.2 AV	54.0	-6.8	2.31 V	282	27.9	19.3

Remarks:

1. Emission Level(dBuV/m) = Raw Value(dBuV) + Correction Factor(dB/m)
2. Correction Factor(dB/m) = Antenna Factor(dB/m) + Cable Factor(dB) – Pre-Amplifier Factor(dB)
3. The other emission levels were very low against the limit.
4. Margin value = Emission Level – Limit value
5. " * ": Fundamental frequency.
6. " # ": The radiated frequency is out of the restricted band.

CHANNEL	TX Channel 157	DETECTOR FUNCTION	Peak (PK)
FREQUENCY RANGE	1GHz ~ 40GHz		Average (AV)

ANTENNA POLARITY & TEST DISTANCE: HORIZONTAL AT 3 M

NO.	FREQ. (MHz)	EMISSION LEVEL (dBuV/m)	LIMIT (dBuV/m)	MARGIN (dB)	ANTENNA HEIGHT (m)	TABLE ANGLE (Degree)	RAW VALUE (dBuV)	CORRECTION FACTOR (dB/m)
1	*5785.00	109.4 PK			2.21 H	353	69.3	40.1
2	*5785.00	99.1 AV			2.21 H	353	59.0	40.1
3	11570.00	60.4 PK	74.0	-13.6	1.53 H	261	41.2	19.2
4	11570.00	47.6 AV	54.0	-6.4	1.53 H	261	28.4	19.2

ANTENNA POLARITY & TEST DISTANCE: VERTICAL AT 3 M

NO.	FREQ. (MHz)	EMISSION LEVEL (dBuV/m)	LIMIT (dBuV/m)	MARGIN (dB)	ANTENNA HEIGHT (m)	TABLE ANGLE (Degree)	RAW VALUE (dBuV)	CORRECTION FACTOR (dB/m)
1	*5785.00	110.2 PK			2.75 V	16	70.1	40.1
2	*5785.00	99.7 AV			2.75 V	16	59.6	40.1
3	11570.00	60.2 PK	74.0	-13.8	2.00 V	194	41.0	19.2
4	11570.00	47.5 AV	54.0	-6.5	2.00 V	194	28.3	19.2

Remarks:

1. Emission Level(dBuV/m) = Raw Value(dBuV) + Correction Factor(dB/m)
2. Correction Factor(dB/m) = Antenna Factor(dB/m) + Cable Factor(dB) – Pre-Amplifier Factor(dB)
3. The other emission levels were very low against the limit.
4. Margin value = Emission Level – Limit value
5. " * ": Fundamental frequency.

CHANNEL	TX Channel 165	DETECTOR FUNCTION	Peak (PK)
FREQUENCY RANGE	1GHz ~ 40GHz		Average (AV)

ANTENNA POLARITY & TEST DISTANCE: HORIZONTAL AT 3 M								
NO.	FREQ. (MHz)	EMISSION LEVEL (dBuV/m)	LIMIT (dBuV/m)	MARGIN (dB)	ANTENNA HEIGHT (m)	TABLE ANGLE (Degree)	RAW VALUE (dBuV)	CORRECTION FACTOR (dB/m)
1	*5825.00	111.7 PK			2.26 H	354	71.6	40.1
2	*5825.00	101.2 AV			2.26 H	354	61.1	40.1
3	11650.00	59.6 PK	74.0	-14.4	1.36 H	256	40.3	19.3
4	11650.00	47.6 AV	54.0	-6.4	1.36 H	256	28.3	19.3
ANTENNA POLARITY & TEST DISTANCE: VERTICAL AT 3 M								
NO.	FREQ. (MHz)	EMISSION LEVEL (dBuV/m)	LIMIT (dBuV/m)	MARGIN (dB)	ANTENNA HEIGHT (m)	TABLE ANGLE (Degree)	RAW VALUE (dBuV)	CORRECTION FACTOR (dB/m)
1	*5825.00	110.2 PK			2.72 V	18	70.1	40.1
2	*5825.00	99.9 AV			2.72 V	18	59.8	40.1
3	11650.00	60.2 PK	74.0	-13.8	1.92 V	294	40.9	19.3
4	11650.00	47.5 AV	54.0	-6.5	1.92 V	294	28.2	19.3

Remarks:

1. Emission Level(dBuV/m) = Raw Value(dBuV) + Correction Factor(dB/m)
2. Correction Factor(dB/m) = Antenna Factor(dB/m) + Cable Factor(dB) – Pre-Amplifier Factor(dB)
3. The other emission levels were very low against the limit.
4. Margin value = Emission Level – Limit value
5. " * ": Fundamental frequency.
6. " # ": The radiated frequency is out of the restricted band.

802.11n (HT40)

CHANNEL	TX Channel 38	DETECTOR FUNCTION	Peak (PK) Average (AV)
FREQUENCY RANGE	1GHz ~ 40GHz		

ANTENNA POLARITY & TEST DISTANCE: HORIZONTAL AT 3 M

NO.	FREQ. (MHz)	EMISSION LEVEL (dBuV/m)	LIMIT (dBuV/m)	MARGIN (dB)	ANTENNA HEIGHT (m)	TABLE ANGLE (Degree)	RAW VALUE (dBuV)	CORRECTION FACTOR (dB/m)
1	5150.00	64.8 PK	74.0	-9.2	1.34 H	350	60.0	4.8
2	5150.00	52.6 AV	54.0	-1.4	1.34 H	350	47.8	4.8
3	*5190.00	98.5 PK			1.65 H	353	59.8	38.7
4	*5190.00	89.3 AV			1.65 H	353	50.6	38.7
5	#10380.00	56.8 PK	74.0	-17.2	1.58 H	24	39.2	17.6
6	#10380.00	45.5 AV	54.0	-8.5	1.58 H	24	27.9	17.6

ANTENNA POLARITY & TEST DISTANCE: VERTICAL AT 3 M

NO.	FREQ. (MHz)	EMISSION LEVEL (dBuV/m)	LIMIT (dBuV/m)	MARGIN (dB)	ANTENNA HEIGHT (m)	TABLE ANGLE (Degree)	RAW VALUE (dBuV)	CORRECTION FACTOR (dB/m)
1	5150.00	64.5 PK	74.0	-9.5	3.22 V	15	59.7	4.8
2	5150.00	51.2 AV	54.0	-2.8	3.22 V	15	46.4	4.8
3	*5190.00	101.6 PK			3.16 V	14	62.9	38.7
4	*5190.00	91.3 AV			3.16 V	14	52.6	38.7
5	#10380.00	59.2 PK	74.0	-14.8	2.87 V	246	41.6	17.6
6	#10380.00	46.2 AV	54.0	-7.8	2.87 V	246	28.6	17.6

Remarks:

1. Emission Level(dBuV/m) = Raw Value(dBuV) + Correction Factor(dB/m)
2. Correction Factor(dB/m) = Antenna Factor(dB/m) + Cable Factor(dB) – Pre-Amplifier Factor(dB)
3. The other emission levels were very low against the limit.
4. Margin value = Emission Level – Limit value
5. " * ": Fundamental frequency.
6. " # ": The radiated frequency is out of the restricted band.

CHANNEL	TX Channel 46	DETECTOR FUNCTION	Peak (PK)
FREQUENCY RANGE	1GHz ~ 40GHz		Average (AV)

ANTENNA POLARITY & TEST DISTANCE: HORIZONTAL AT 3 M								
NO.	FREQ. (MHz)	EMISSION LEVEL (dBuV/m)	LIMIT (dBuV/m)	MARGIN (dB)	ANTENNA HEIGHT (m)	TABLE ANGLE (Degree)	RAW VALUE (dBuV)	CORRECTION FACTOR (dB/m)
1	5150.00	64.9 PK	74.0	-9.1	1.54 H	352	60.1	4.8
2	5150.00	52.0 AV	54.0	-2.0	1.54 H	352	47.2	4.8
3	*5230.00	108.0 PK			1.62 H	351	69.1	38.9
4	*5230.00	96.3 AV			1.62 H	351	57.4	38.9
5	#10460.00	59.0 PK	74.0	-15.0	1.56 H	298	40.8	18.2
6	#10460.00	47.0 AV	54.0	-7.0	1.56 H	298	28.8	18.2

ANTENNA POLARITY & TEST DISTANCE: VERTICAL AT 3 M								
NO.	FREQ. (MHz)	EMISSION LEVEL (dBuV/m)	LIMIT (dBuV/m)	MARGIN (dB)	ANTENNA HEIGHT (m)	TABLE ANGLE (Degree)	RAW VALUE (dBuV)	CORRECTION FACTOR (dB/m)
1	5150.00	64.7 PK	74.0	-9.3	2.69 V	13	59.9	4.8
2	5150.00	51.6 AV	54.0	-2.4	2.69 V	13	46.8	4.8
3	*5230.00	108.6 PK			2.97 V	14	69.7	38.9
4	*5230.00	97.6 AV			2.97 V	14	58.7	38.9
5	#10460.00	64.3 PK	74.0	-9.7	2.95 V	337	46.1	18.2
6	#10460.00	51.1 AV	54.0	-2.9	2.95 V	337	32.9	18.2

Remarks:

1. Emission Level(dBuV/m) = Raw Value(dBuV) + Correction Factor(dB/m)
2. Correction Factor(dB/m) = Antenna Factor(dB/m) + Cable Factor(dB) – Pre-Amplifier Factor(dB)
3. The other emission levels were very low against the limit.
4. Margin value = Emission Level – Limit value
5. " * ": Fundamental frequency.
6. " # ": The radiated frequency is out of the restricted band.

CHANNEL	TX Channel 151	DETECTOR FUNCTION	Peak (PK)
FREQUENCY RANGE	1GHz ~ 40GHz		Average (AV)

ANTENNA POLARITY & TEST DISTANCE: HORIZONTAL AT 3 M								
NO.	FREQ. (MHz)	EMISSION LEVEL (dBuV/m)	LIMIT (dBuV/m)	MARGIN (dB)	ANTENNA HEIGHT (m)	TABLE ANGLE (Degree)	RAW VALUE (dBuV)	CORRECTION FACTOR (dB/m)
1	*5755.00	108.0 PK			1.54 H	349	68.0	40.0
2	*5755.00	98.5 AV			1.54 H	349	58.5	40.0
3	11510.00	60.2 PK	74.0	-13.8	1.58 H	195	40.9	19.3
4	11510.00	47.8 AV	54.0	-6.2	1.58 H	195	28.5	19.3
ANTENNA POLARITY & TEST DISTANCE: VERTICAL AT 3 M								
NO.	FREQ. (MHz)	EMISSION LEVEL (dBuV/m)	LIMIT (dBuV/m)	MARGIN (dB)	ANTENNA HEIGHT (m)	TABLE ANGLE (Degree)	RAW VALUE (dBuV)	CORRECTION FACTOR (dB/m)
1	*5755.00	106.9 PK			2.88 V	16	66.9	40.0
2	*5755.00	96.9 AV			2.88 V	16	56.9	40.0
3	11510.00	59.4 PK	74.0	-14.6	2.13 V	234	40.1	19.3
4	11510.00	48.1 AV	54.0	-5.9	2.13 V	234	28.8	19.3

Remarks:

1. Emission Level(dBuV/m) = Raw Value(dBuV) + Correction Factor(dB/m)
2. Correction Factor(dB/m) = Antenna Factor(dB/m) + Cable Factor(dB) – Pre-Amplifier Factor(dB)
3. The other emission levels were very low against the limit.
4. Margin value = Emission Level – Limit value
5. " * ": Fundamental frequency.
6. " # ": The radiated frequency is out of the restricted band.

CHANNEL	TX Channel 159	DETECTOR FUNCTION	Peak (PK)
FREQUENCY RANGE	1GHz ~ 40GHz		Average (AV)

ANTENNA POLARITY & TEST DISTANCE: HORIZONTAL AT 3 M								
NO.	FREQ. (MHz)	EMISSION LEVEL (dBuV/m)	LIMIT (dBuV/m)	MARGIN (dB)	ANTENNA HEIGHT (m)	TABLE ANGLE (Degree)	RAW VALUE (dBuV)	CORRECTION FACTOR (dB/m)
1	*5795.00	107.1 PK			1.74 H	352	67.0	40.1
2	*5795.00	97.5 AV			1.74 H	352	57.4	40.1
3	11590.00	60.0 PK	74.0	-14.0	1.75 H	234	40.8	19.2
4	11590.00	48.4 AV	54.0	-5.6	1.75 H	234	29.2	19.2
ANTENNA POLARITY & TEST DISTANCE: VERTICAL AT 3 M								
NO.	FREQ. (MHz)	EMISSION LEVEL (dBuV/m)	LIMIT (dBuV/m)	MARGIN (dB)	ANTENNA HEIGHT (m)	TABLE ANGLE (Degree)	RAW VALUE (dBuV)	CORRECTION FACTOR (dB/m)
1	*5795.00	106.9 PK			2.75 V	17	66.8	40.1
2	*5795.00	97.4 AV			2.75 V	17	57.3	40.1
3	11590.00	60.2 PK	74.0	-13.8	1.93 V	285	41.0	19.2
4	11590.00	48.4 AV	54.0	-5.6	1.93 V	285	29.2	19.2

Remarks:

1. Emission Level(dBuV/m) = Raw Value(dBuV) + Correction Factor(dB/m)
2. Correction Factor(dB/m) = Antenna Factor(dB/m) + Cable Factor(dB) – Pre-Amplifier Factor(dB)
3. The other emission levels were very low against the limit.
4. Margin value = Emission Level – Limit value
5. " * ": Fundamental frequency.
6. " # ": The radiated frequency is out of the restricted band.

802.11ac (VHT80)

CHANNEL	TX Channel 42	DETECTOR FUNCTION	Peak (PK) Average (AV)
FREQUENCY RANGE	1GHz ~ 40GHz		

ANTENNA POLARITY & TEST DISTANCE: HORIZONTAL AT 3 M

NO.	FREQ. (MHz)	EMISSION LEVEL (dBuV/m)	LIMIT (dBuV/m)	MARGIN (dB)	ANTENNA HEIGHT (m)	TABLE ANGLE (Degree)	RAW VALUE (dBuV)	CORRECTION FACTOR (dB/m)
1	5150.00	64.1 PK	74.0	-9.9	1.46 H	351	59.3	4.8
2	5150.00	52.3 AV	54.0	-1.7	1.46 H	351	47.5	4.8
3	*5210.00	95.6 PK			1.30 H	350	56.9	38.7
4	*5210.00	84.7 AV			1.30 H	350	46.0	38.7
5	#10420.00	59.7 PK	74.0	-14.3	1.46 H	254	41.9	17.8
6	#10420.00	46.1 AV	54.0	-7.9	1.46 H	254	28.3	17.8

ANTENNA POLARITY & TEST DISTANCE: VERTICAL AT 3 M

NO.	FREQ. (MHz)	EMISSION LEVEL (dBuV/m)	LIMIT (dBuV/m)	MARGIN (dB)	ANTENNA HEIGHT (m)	TABLE ANGLE (Degree)	RAW VALUE (dBuV)	CORRECTION FACTOR (dB/m)
1	5150.00	63.3 PK	74.0	-10.7	2.68 V	15	58.5	4.8
2	5150.00	51.6 AV	54.0	-2.4	2.68 V	15	46.8	4.8
3	*5210.00	96.3 PK			2.84 V	11	57.6	38.7
4	*5210.00	85.4 AV			2.84 V	11	46.7	38.7
5	#10420.00	59.1 PK	74.0	-14.9	2.46 V	333	41.3	17.8
6	#10420.00	46.6 AV	54.0	-7.4	2.46 V	333	28.8	17.8

Remarks:

1. Emission Level(dBuV/m) = Raw Value(dBuV) + Correction Factor(dB/m)
2. Correction Factor(dB/m) = Antenna Factor(dB/m) + Cable Factor(dB) – Pre-Amplifier Factor(dB)
3. The other emission levels were very low against the limit.
4. Margin value = Emission Level – Limit value
5. " * ": Fundamental frequency.
6. " # ": The radiated frequency is out of the restricted band.

CHANNEL	TX Channel 155	DETECTOR FUNCTION	Peak (PK)
FREQUENCY RANGE	1GHz ~ 40GHz		Average (AV)

ANTENNA POLARITY & TEST DISTANCE: HORIZONTAL AT 3 M								
NO.	FREQ. (MHz)	EMISSION LEVEL (dBuV/m)	LIMIT (dBuV/m)	MARGIN (dB)	ANTENNA HEIGHT (m)	TABLE ANGLE (Degree)	RAW VALUE (dBuV)	CORRECTION FACTOR (dB/m)
1	*5775.00	107.2 PK			1.33 H	349	67.2	40.0
2	*5775.00	95.3 AV			1.33 H	349	55.3	40.0
3	11550.00	60.1 PK	74.0	-13.9	2.21 H	302	40.9	19.2
4	11550.00	48.3 AV	54.0	-5.7	2.21 H	302	29.1	19.2
ANTENNA POLARITY & TEST DISTANCE: VERTICAL AT 3 M								
NO.	FREQ. (MHz)	EMISSION LEVEL (dBuV/m)	LIMIT (dBuV/m)	MARGIN (dB)	ANTENNA HEIGHT (m)	TABLE ANGLE (Degree)	RAW VALUE (dBuV)	CORRECTION FACTOR (dB/m)
1	*5775.00	105.0 PK			2.77 V	16	65.0	40.0
2	*5775.00	93.3 AV			2.77 V	16	53.3	40.0
3	11550.00	60.1 PK	74.0	-13.9	2.01 V	300	40.9	19.2
4	11550.00	48.0 AV	54.0	-6.0	2.01 V	300	28.8	19.2

Remarks:

1. Emission Level(dBuV/m) = Raw Value(dBuV) + Correction Factor(dB/m)
2. Correction Factor(dB/m) = Antenna Factor(dB/m) + Cable Factor(dB) – Pre-Amplifier Factor(dB)
3. The other emission levels were very low against the limit.
4. Margin value = Emission Level – Limit value
5. " * ": Fundamental frequency.
6. " # ": The radiated frequency is out of the restricted band.

Below 1GHz Worst-Case Data:

802.11a

CHANNEL	TX Channel 149	DETECTOR FUNCTION	Quasi-Peak (QP)
FREQUENCY RANGE	9kHz ~ 1GHz		

ANTENNA POLARITY & TEST DISTANCE: HORIZONTAL AT 3 M								
NO.	FREQ. (MHz)	EMISSION LEVEL (dBuV/m)	LIMIT (dBuV/m)	MARGIN (dB)	ANTENNA HEIGHT (m)	TABLE ANGLE (Degree)	RAW VALUE (dBuV)	CORRECTION FACTOR (dB/m)
1	57.12	28.1 QP	40.0	-11.9	2.00 H	165	42.7	-14.6
2	187.39	28.7 QP	43.5	-14.8	2.00 H	286	44.6	-15.9
3	204.89	28.8 QP	43.5	-14.7	1.00 H	248	45.3	-16.5
4	249.60	35.3 QP	46.0	-10.7	1.00 H	138	49.3	-14.0
5	374.04	37.6 QP	46.0	-8.4	1.00 H	149	48.1	-10.5
6	875.67	44.2 QP	46.0	-1.8	2.00 H	337	44.3	-0.1
ANTENNA POLARITY & TEST DISTANCE: VERTICAL AT 3 M								
NO.	FREQ. (MHz)	EMISSION LEVEL (dBuV/m)	LIMIT (dBuV/m)	MARGIN (dB)	ANTENNA HEIGHT (m)	TABLE ANGLE (Degree)	RAW VALUE (dBuV)	CORRECTION FACTOR (dB/m)
1	59.06	36.9 QP	40.0	-3.1	1.50 V	305	51.6	-14.7
2	125.17	28.9 QP	43.5	-14.6	1.00 V	240	45.0	-16.1
3	183.50	27.9 QP	43.5	-15.6	1.00 V	165	43.4	-15.5
4	249.60	35.3 QP	46.0	-10.7	2.00 V	209	49.3	-14.0
5	374.04	41.8 QP	46.0	-4.2	1.00 V	195	52.3	-10.5
6	875.67	43.6 QP	46.0	-2.4	1.50 V	6	43.7	-0.1

Remarks:

1. Emission Level(dBuV/m) = Raw Value(dBuV) + Correction Factor(dB/m)
2. Correction Factor(dB/m) = Antenna Factor(dB/m) + Cable Factor(dB) – Pre-Amplifier Factor(dB)
3. The other emission levels were very low against the limit.
4. Margin value = Emission Level – Limit value

4.2 Conducted Emission Measurement

4.2.1 Limits of Conducted Emission Measurement

Frequency (MHz)	Conducted Limit (dBuV)	
	Quasi-peak	Average
0.15 - 0.5	66 - 56	56 - 46
0.50 - 5.0	56	46
5.0 - 30.0	60	50

- Note:** 1. The lower limit shall apply at the transition frequencies.
 2. The limit decreases in line with the logarithm of the frequency in the range of 0.15 to 0.50MHz.

4.2.2 Test Instruments

Description & Manufacturer	Model No.	Serial No.	Cal. Date	Cal. Due
Test Receiver ROHDE & SCHWARZ	ESCS30	100289	Dec. 23, 2015	Dec. 22, 2016
RF signal cable (with 10dB PAD) Woken	5D-FB	Cable-cond2-01	Dec. 26, 2015	Dec. 25, 2016
LISN ROHDE & SCHWARZ (EUT)	ESH2-Z5	100100	Jan. 11, 2016	Jan. 10, 2017
LISN ROHDE & SCHWARZ (Peripheral)	ESH3-Z5	100312	Jul. 26, 2016	Jul. 25, 2017
Software ADT	BV ADT_Cond_ V7.3.7.3	NA	NA	NA

- Note:** 1. The calibration interval of the above test instruments is 12 months and the calibrations are traceable to NML/ROC and NIST/USA.
 2. The test was performed in HwaYa Shielded Room 2.
 3. The VCCI Site Registration No. is C-2047.

4.2.3 Test Procedures

- The EUT was placed 0.4 meters from the conducting wall of the shielded room with EUT being connected to the power mains through a line impedance stabilization network (LISN). Other support units were connected to the power mains through another LISN. The two LISNs provide 50 ohm/ 50uH of coupling impedance for the measuring instrument.
- Both lines of the power mains connected to the EUT were checked for maximum conducted interference.
- The frequency range from 150kHz to 30MHz was searched. Emission levels under (Limit - 20dB) was not recorded.

NOTE: The resolution bandwidth and video bandwidth of test receiver is 9kHz for quasi-peak detection (QP) and average detection (AV) at frequency 0.15MHz-30MHz.

4.2.4 Deviation from Test Standard

No deviation.

4.2.5 Test Setup

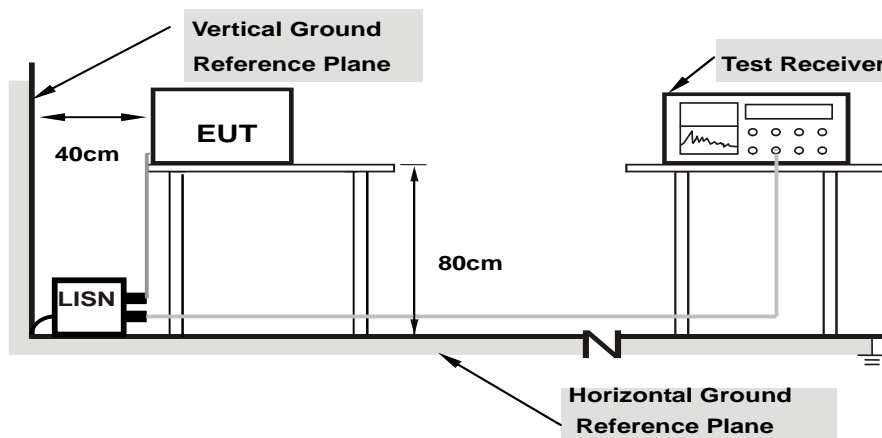

Note: 1.Support units were connected to second LISN.

For the actual test configuration, please refer to the attached file (Test Setup Photo).

4.2.6 EUT Operating Conditions

Same as 4.1.6.

4.2.7 Test Results

Test Mode A

Phase	Line (L)	Detector Function	Quasi-Peak (QP) / Average (AV)
-------	----------	-------------------	--------------------------------

No	Freq. [MHz]	Corr. Factor (dB)	Reading Value		Emission Level		Limit		Margin	
			[dB (uV)]		[dB (uV)]		[dB (uV)]		(dB)	
			Q.P.	AV.	Q.P.	AV.	Q.P.	AV.	Q.P.	AV.
1	0.15000	10.12	38.41	28.61	48.53	38.73	66.00	56.00	-17.47	-17.27
2	0.17734	10.14	33.83	23.77	43.97	33.91	64.61	54.61	-20.64	-20.70
3	0.21135	10.16	29.26	20.04	39.42	30.20	63.15	53.15	-23.73	-22.95
4	0.41172	10.19	28.51	20.78	38.70	30.97	57.61	47.61	-18.91	-16.64
5	13.84766	10.52	35.79	30.28	46.31	40.80	60.00	50.00	-13.69	-9.20
6	23.94531	10.53	33.19	27.83	43.72	38.36	60.00	50.00	-16.28	-11.64

Remarks:

1. Q.P. and AV. are abbreviations of quasi-peak and average individually.
2. The emission levels of other frequencies were very low against the limit.
3. Margin value = Emission level - Limit value
4. Correction factor = Insertion loss + Cable loss
5. Emission Level = Correction Factor + Reading Value.

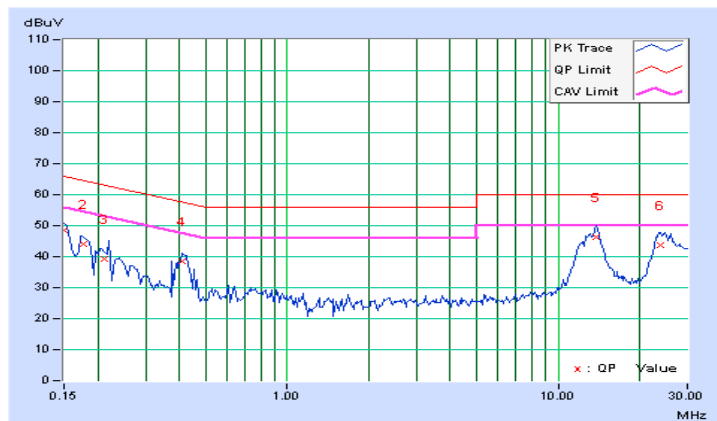

Phase	Neutral (N)	Detector Function	Quasi-Peak (QP) / Average (AV)
-------	-------------	-------------------	--------------------------------

No	Freq. [MHz]	Corr. Factor (dB)	Reading Value [dB (uV)]		Emission Level [dB (uV)]		Limit [dB (uV)]		Margin (dB)	
			Q.P.	AV.	Q.P.	AV.	Q.P.	AV.	Q.P.	AV.
			1	0.15000	10.13	37.66	27.84	47.79	37.97	66.00
2	0.17344	10.14	34.10	19.89	44.24	30.03	64.79	54.79	-20.55	-24.76
3	0.41172	10.19	26.98	18.87	37.17	29.06	57.61	47.61	-20.44	-18.55
4	13.94922	10.63	35.42	30.01	46.05	40.64	60.00	50.00	-13.95	-9.36
5	25.34766	10.65	31.43	26.16	42.08	36.81	60.00	50.00	-17.92	-13.19
6	28.88281	10.57	29.01	23.88	39.58	34.45	60.00	50.00	-20.42	-15.55

Remarks:

1. Q.P. and AV. are abbreviations of quasi-peak and average individually.
2. The emission levels of other frequencies were very low against the limit.
3. Margin value = Emission level - Limit value
4. Correction factor = Insertion loss + Cable loss
5. Emission Level = Correction Factor + Reading Value.

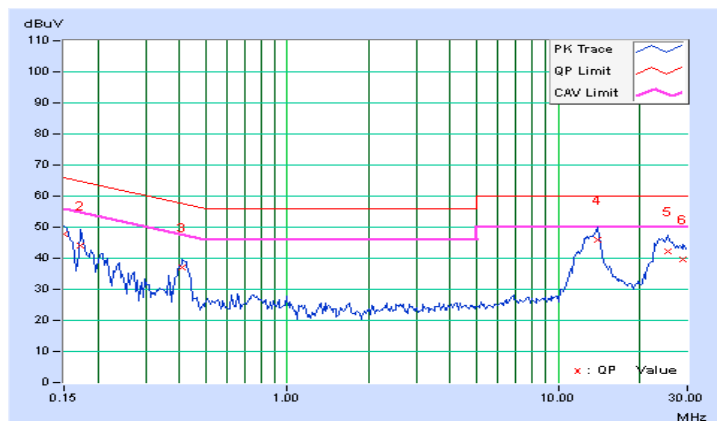

Test Mode B

Phase	Line (L)	Detector Function	Quasi-Peak (QP) / Average (AV)
-------	----------	-------------------	--------------------------------

No	Freq. [MHz]	Corr. Factor (dB)	Reading Value [dB (uV)]		Emission Level [dB (uV)]		Limit [dB (uV)]		Margin (dB)	
			Q.P.	AV.	Q.P.	AV.	Q.P.	AV.	Q.P.	AV.
			1	0.15000	10.12	36.70	27.58	46.82	37.70	66.00
2	0.17734	10.14	32.22	21.66	42.36	31.80	64.61	54.61	-22.25	-22.81
3	0.41172	10.19	29.97	21.21	40.16	31.40	57.61	47.61	-17.45	-16.21
4	13.54688	10.52	35.64	30.26	46.16	40.78	60.00	50.00	-13.84	-9.22
5	22.74609	10.56	31.11	25.43	41.67	35.99	60.00	50.00	-18.33	-14.01
6	24.91406	10.51	32.21	26.64	42.72	37.15	60.00	50.00	-17.28	-12.85

Remarks:

1. Q.P. and AV. are abbreviations of quasi-peak and average individually.
2. The emission levels of other frequencies were very low against the limit.
3. Margin value = Emission level - Limit value
4. Correction factor = Insertion loss + Cable loss
5. Emission Level = Correction Factor + Reading Value.

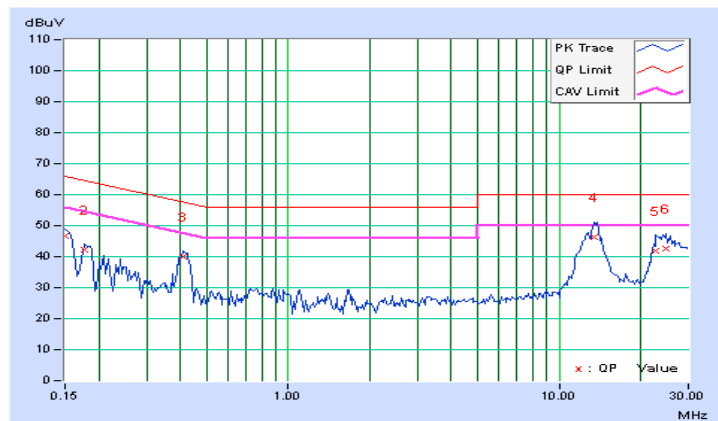

Phase	Neutral (N)	Detector Function	Quasi-Peak (QP) / Average (AV)
-------	-------------	-------------------	--------------------------------

No	Freq. [MHz]	Corr. Factor (dB)	Reading Value [dB (uV)]		Emission Level [dB (uV)]		Limit [dB (uV)]		Margin (dB)	
			Q.P.	AV.	Q.P.	AV.	Q.P.	AV.	Q.P.	AV.
			1	0.15000	10.13	36.11	26.60	46.24	36.73	66.00
2	0.17344	10.14	32.19	18.47	42.33	28.61	64.79	54.79	-22.46	-26.18
3	0.41563	10.19	27.88	20.03	38.07	30.22	57.54	47.54	-19.47	-17.32
4	12.70313	10.61	32.74	27.30	43.35	37.91	60.00	50.00	-16.65	-12.09
5	13.55078	10.62	35.11	29.52	45.73	40.14	60.00	50.00	-14.27	-9.86
6	24.02734	10.69	32.90	27.46	43.59	38.15	60.00	50.00	-16.41	-11.85

Remarks:

1. Q.P. and AV. are abbreviations of quasi-peak and average individually.
2. The emission levels of other frequencies were very low against the limit.
3. Margin value = Emission level - Limit value
4. Correction factor = Insertion loss + Cable loss
5. Emission Level = Correction Factor + Reading Value.

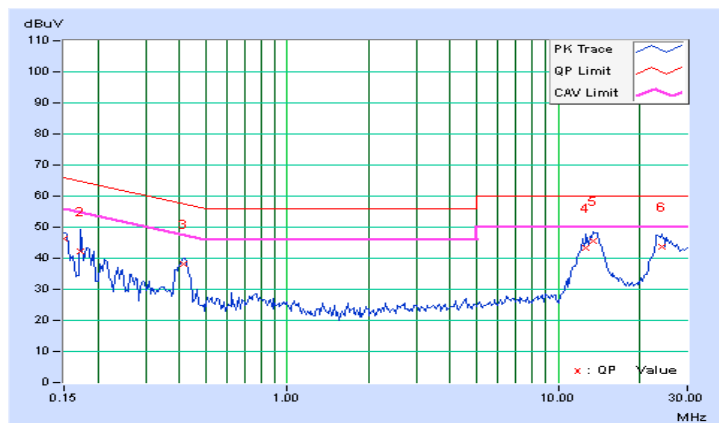

Test Mode C

Phase	Line (L)	Detector Function	Quasi-Peak (QP) / Average (AV)
-------	----------	-------------------	--------------------------------

No	Freq. [MHz]	Corr. Factor (dB)	Reading Value [dB (uV)]		Emission Level [dB (uV)]		Limit [dB (uV)]		Margin (dB)	
			Q.P.	AV.	Q.P.	AV.	Q.P.	AV.	Q.P.	AV.
			1	0.15000	10.12	37.38	27.96	47.50	38.08	66.00
2	0.20469	10.16	29.21	17.32	39.37	27.48	63.42	53.42	-24.05	-25.94
3	0.41172	10.19	29.39	21.39	39.58	31.58	57.61	47.61	-18.03	-16.03
4	12.41797	10.51	31.81	26.48	42.32	36.99	60.00	50.00	-17.68	-13.01
5	13.96484	10.52	34.57	29.11	45.09	39.63	60.00	50.00	-14.91	-10.37
6	23.83984	10.54	33.14	27.84	43.68	38.38	60.00	50.00	-16.32	-11.62

Remarks:

1. Q.P. and AV. are abbreviations of quasi-peak and average individually.
2. The emission levels of other frequencies were very low against the limit.
3. Margin value = Emission level - Limit value
4. Correction factor = Insertion loss + Cable loss
5. Emission Level = Correction Factor + Reading Value.

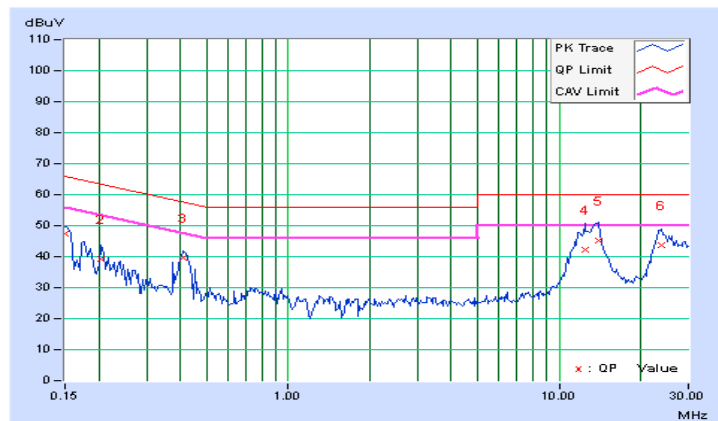

Phase	Neutral (N)	Detector Function	Quasi-Peak (QP) / Average (AV)
-------	-------------	-------------------	--------------------------------

No	Freq. [MHz]	Corr. Factor (dB)	Reading Value [dB (uV)]		Emission Level [dB (uV)]		Limit [dB (uV)]		Margin (dB)	
			Q.P.	AV.	Q.P.	AV.	Q.P.	AV.	Q.P.	AV.
			1	0.15781	10.13	34.55	19.87	44.68	30.00	65.58
2	0.17734	10.15	32.30	21.72	42.45	31.87	64.61	54.61	-22.16	-22.74
3	0.41563	10.19	27.58	19.48	37.77	29.67	57.54	47.54	-19.77	-17.87
4	0.77500	10.20	12.63	4.84	22.83	15.04	56.00	46.00	-33.17	-30.96
5	13.65234	10.63	36.71	31.26	47.34	41.89	60.00	50.00	-12.66	-8.11
6	23.76953	10.69	33.16	27.78	43.85	38.47	60.00	50.00	-16.15	-11.53

Remarks:

1. Q.P. and AV. are abbreviations of quasi-peak and average individually.
2. The emission levels of other frequencies were very low against the limit.
3. Margin value = Emission level - Limit value
4. Correction factor = Insertion loss + Cable loss
5. Emission Level = Correction Factor + Reading Value.

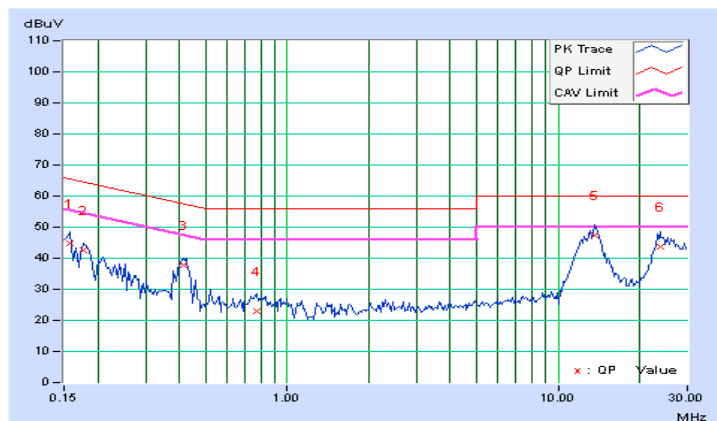

Test Mode D

Phase	Line (L)	Detector Function	Quasi-Peak (QP) / Average (AV)
-------	----------	-------------------	--------------------------------

No	Freq. [MHz]	Corr. Factor (dB)	Reading Value [dB (uV)]		Emission Level [dB (uV)]		Limit [dB (uV)]		Margin (dB)	
			Q.P.	AV.	Q.P.	AV.	Q.P.	AV.	Q.P.	AV.
			1	0.15000	10.12	36.80	27.82	46.92	37.94	66.00
2	0.18125	10.14	32.12	22.41	42.26	32.55	64.43	54.43	-22.17	-21.88
3	0.22422	10.16	21.01	7.93	31.17	18.09	62.66	52.66	-31.49	-34.57
4	0.41172	10.19	29.45	21.41	39.64	31.60	57.61	47.61	-17.97	-16.01
5	13.82813	10.52	35.47	29.94	45.99	40.46	60.00	50.00	-14.01	-9.54
6	23.37109	10.55	32.96	27.58	43.51	38.13	60.00	50.00	-16.49	-11.87

Remarks:

1. Q.P. and AV. are abbreviations of quasi-peak and average individually.
2. The emission levels of other frequencies were very low against the limit.
3. Margin value = Emission level - Limit value
4. Correction factor = Insertion loss + Cable loss
5. Emission Level = Correction Factor + Reading Value.

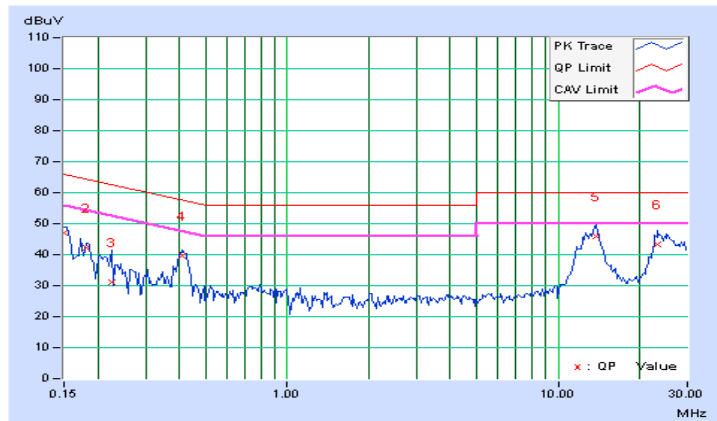

Phase	Neutral (N)	Detector Function	Quasi-Peak (QP) / Average (AV)
-------	-------------	-------------------	--------------------------------

No	Freq. [MHz]	Corr. Factor (dB)	Reading Value [dB (uV)]		Emission Level [dB (uV)]		Limit [dB (uV)]		Margin (dB)	
			Q.P.	AV.	Q.P.	AV.	Q.P.	AV.	Q.P.	AV.
			1	0.15000	10.13	36.28	26.89	46.41	37.02	66.00
2	0.17734	10.15	32.20	21.03	42.35	31.18	64.61	54.61	-22.26	-23.43
3	0.41563	10.19	27.88	20.01	38.07	30.20	57.54	47.54	-19.47	-17.34
4	12.53906	10.61	32.02	26.66	42.63	37.27	60.00	50.00	-17.37	-12.73
5	13.57813	10.62	34.56	29.22	45.18	39.84	60.00	50.00	-14.82	-10.16
6	23.36719	10.70	32.59	27.24	43.29	37.94	60.00	50.00	-16.71	-12.06

Remarks:

1. Q.P. and AV. are abbreviations of quasi-peak and average individually.
2. The emission levels of other frequencies were very low against the limit.
3. Margin value = Emission level - Limit value
4. Correction factor = Insertion loss + Cable loss
5. Emission Level = Correction Factor + Reading Value.

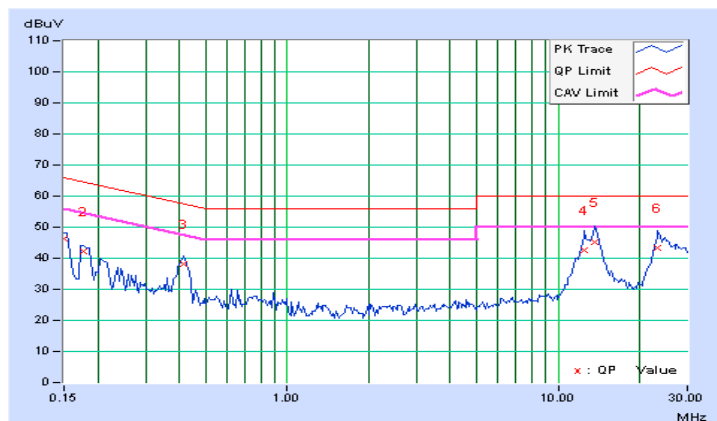

Test Mode E

Phase	Line (L)	Detector Function	Quasi-Peak (QP) / Average (AV)
-------	----------	-------------------	--------------------------------

No	Freq. [MHz]	Corr. Factor (dB)	Reading Value [dB (uV)]		Emission Level [dB (uV)]		Limit [dB (uV)]		Margin (dB)	
			Q.P.	AV.	Q.P.	AV.	Q.P.	AV.	Q.P.	AV.
			1	0.15000	10.12	36.72	27.60	46.84	37.72	66.00
2	0.17344	10.14	32.51	19.17	42.65	29.31	64.79	54.79	-22.14	-25.48
3	0.20859	10.16	27.79	18.66	37.95	28.82	63.26	53.26	-25.31	-24.44
4	0.41563	10.19	29.45	21.47	39.64	31.66	57.54	47.54	-17.90	-15.88
5	13.38672	10.52	35.16	29.67	45.68	40.19	60.00	50.00	-14.32	-9.81
6	24.93359	10.51	32.00	26.80	42.51	37.31	60.00	50.00	-17.49	-12.69

Remarks:

1. Q.P. and AV. are abbreviations of quasi-peak and average individually.
2. The emission levels of other frequencies were very low against the limit.
3. Margin value = Emission level - Limit value
4. Correction factor = Insertion loss + Cable loss
5. Emission Level = Correction Factor + Reading Value.

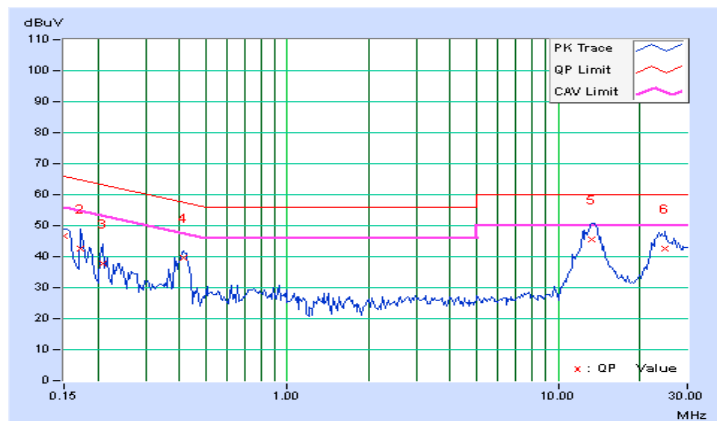

Phase	Neutral (N)	Detector Function	Quasi-Peak (QP) / Average (AV)
-------	-------------	-------------------	--------------------------------

No	Freq. [MHz]	Corr. Factor (dB)	Reading Value [dB (uV)]		Emission Level [dB (uV)]		Limit [dB (uV)]		Margin (dB)	
			Q.P.	AV.	Q.P.	AV.	Q.P.	AV.	Q.P.	AV.
			1	0.15000	10.13	36.21	26.89	46.34	37.02	66.00
2	0.16953	10.14	29.87	12.72	40.01	22.86	64.98	54.98	-24.97	-32.12
3	0.20469	10.16	27.73	15.76	37.89	25.92	63.42	53.42	-25.53	-27.50
4	0.41563	10.19	28.00	19.93	38.19	30.12	57.54	47.54	-19.35	-17.42
5	13.69141	10.63	36.65	31.06	47.28	41.69	60.00	50.00	-12.72	-8.31
6	23.66797	10.69	33.01	27.71	43.70	38.40	60.00	50.00	-16.30	-11.60

Remarks:

1. Q.P. and AV. are abbreviations of quasi-peak and average individually.
2. The emission levels of other frequencies were very low against the limit.
3. Margin value = Emission level - Limit value
4. Correction factor = Insertion loss + Cable loss
5. Emission Level = Correction Factor + Reading Value.

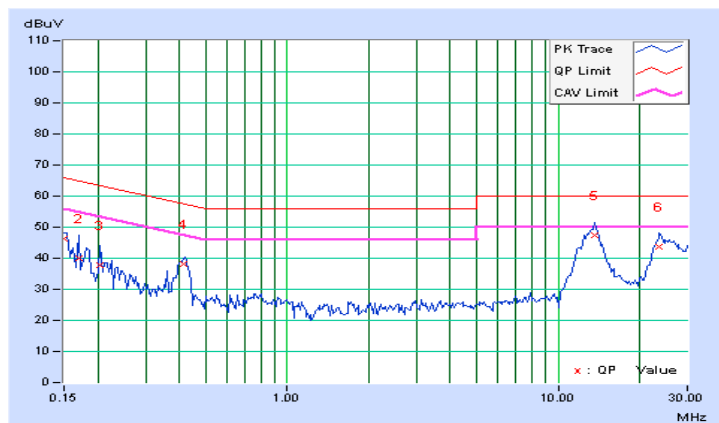

Test Mode F

Phase	Line (L)	Detector Function	Quasi-Peak (QP) / Average (AV)
-------	----------	-------------------	--------------------------------

No	Freq. [MHz]	Corr. Factor (dB)	Reading Value [dB (uV)]		Emission Level [dB (uV)]		Limit [dB (uV)]		Margin (dB)	
			Q.P.	AV.	Q.P.	AV.	Q.P.	AV.	Q.P.	AV.
			1	0.15000	10.12	36.58	27.68	46.70	37.80	66.00
2	0.18125	10.14	31.94	22.37	42.08	32.51	64.43	54.43	-22.35	-21.92
3	0.41172	10.19	30.08	21.49	40.27	31.68	57.61	47.61	-17.34	-15.93
4	13.46484	10.52	35.89	30.76	46.41	41.28	60.00	50.00	-13.59	-8.72
5	23.04297	10.55	32.57	26.88	43.12	37.43	60.00	50.00	-16.88	-12.57
6	25.54297	10.50	31.88	26.23	42.38	36.73	60.00	50.00	-17.62	-13.27

Remarks:

1. Q.P. and AV. are abbreviations of quasi-peak and average individually.
2. The emission levels of other frequencies were very low against the limit.
3. Margin value = Emission level - Limit value
4. Correction factor = Insertion loss + Cable loss
5. Emission Level = Correction Factor + Reading Value.

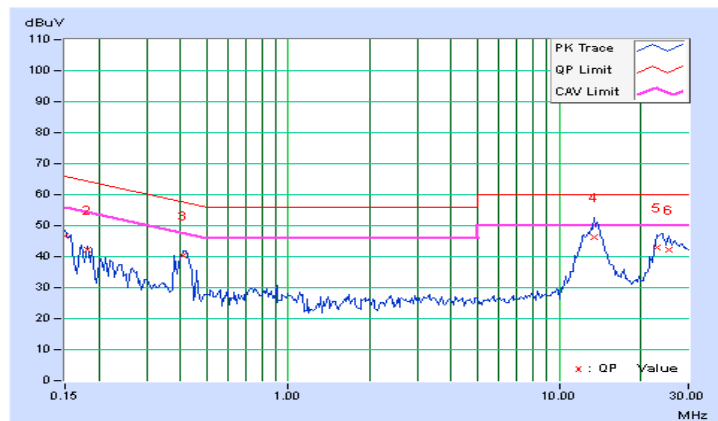

Phase	Neutral (N)	Detector Function	Quasi-Peak (QP) / Average (AV)
-------	-------------	-------------------	--------------------------------

No	Freq. [MHz]	Corr. Factor (dB)	Reading Value [dB (uV)]		Emission Level [dB (uV)]		Limit [dB (uV)]		Margin (dB)	
			Q.P.	AV.	Q.P.	AV.	Q.P.	AV.	Q.P.	AV.
			1	0.15000	10.13	36.21	27.05	46.34	37.18	66.00
2	0.17734	10.15	32.38	20.79	42.53	30.94	64.61	54.61	-22.08	-23.67
3	0.41172	10.19	28.47	20.01	38.66	30.20	57.61	47.61	-18.95	-17.41
4	12.70313	10.61	33.68	28.18	44.29	38.79	60.00	50.00	-15.71	-11.21
5	13.33984	10.62	34.65	29.25	45.27	39.87	60.00	50.00	-14.73	-10.13
6	23.76172	10.69	33.08	27.68	43.77	38.37	60.00	50.00	-16.23	-11.63

Remarks:

1. Q.P. and AV. are abbreviations of quasi-peak and average individually.
2. The emission levels of other frequencies were very low against the limit.
3. Margin value = Emission level - Limit value
4. Correction factor = Insertion loss + Cable loss
5. Emission Level = Correction Factor + Reading Value.

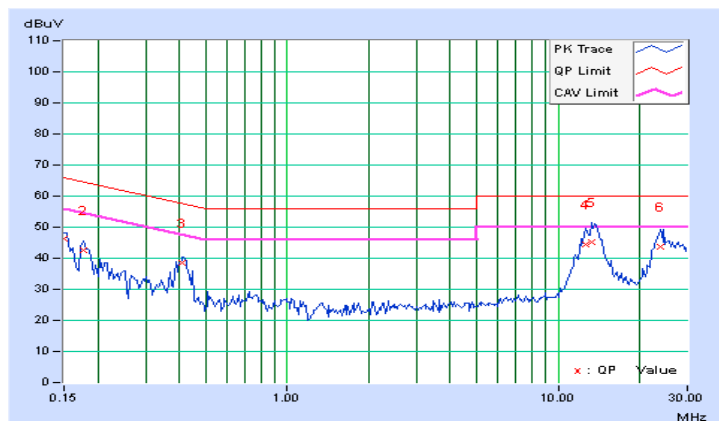

4.3 Transmit Power Measurement

4.3.1 Limits of Transmit Power Measurement

Operation Band	EUT Category		LIMIT
U-NII-1	√	Outdoor Access Point	1 Watt (30 dBm) (Max. e.i.r.p ≤ 125mW(21 dBm) at any elevation angle above 30 degrees as measured from the horizon)
		Fixed point-to-point Access Point	1 Watt (30 dBm)
		Indoor Access Point	1 Watt (30 dBm)
		Mobile and Portable client device	250mW (24 dBm)
U-NII-2A	-		250mW (24 dBm) or 11 dBm+10 log B*
U-NII-2C	-		250mW (24 dBm) or 11 dBm+10 log B*
U-NII-3	√		1 Watt (30 dBm)

*B is the 26 dB emission bandwidth in megahertz

Per KDB 662911 Method of conducted output power measurement on IEEE 802.11 devices,

Array Gain = 0 dB (i.e., no array gain) for $N_{ANT} \leq 4$;

Array Gain = 0 dB (i.e., no array gain) for channel widths ≥ 40 MHz for any N_{ANT} ;

Array Gain = $5 \log(N_{ANT}/N_{SS})$ dB or 3 dB, whichever is less for 20-MHz channel widths with $N_{ANT} \geq 5$.

For power measurements on all other devices: Array Gain = $10 \log(N_{ANT}/N_{SS})$ dB.

4.3.2 Test Setup

For Power Output Measurement

802.11a, 802.11n (HT20), 802.11n (HT40)

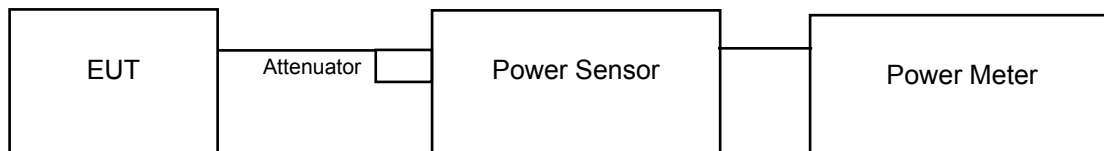

802.11ac (VHT80)

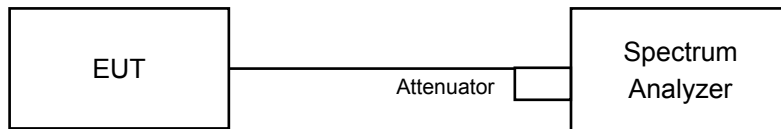

For 26dB Bandwidth

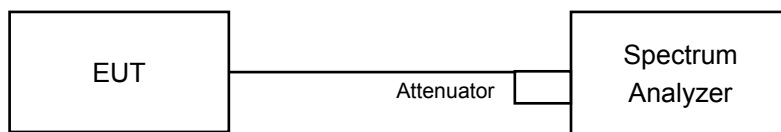

4.3.3 Test Instruments

Refer to section 4.1.2 to get information of above instrument.

4.3.4 Test Procedure

For Average Power Measurement

For 802.11a, 802.11n (HT20), 802.11n (HT40)

Method PM is used to perform output power measurement, trigger and gating function of wide band power meter is enabled to measure max output power of TX on burst. Duty factor is not added to measured value.

For 802.11ac (VHT80)

- 1) Set span to encompass the entire 26 dB EBW (or, alternatively, the entire 99% occupied bandwidth) of the signal.
- 2) Set sweep trigger to "free run".
- 3) Set RBW = 1 MHz.
- 4) Set VBW \geq 3 MHz.
- 5) Number of points in sweep \geq 2 Span / RBW.
- 6) Sweep time \leq (number of points in sweep) * T
- 7) Using emission bandwidth to determine the frequency span for integration the channel bandwidth.
- 8) Detector = RMS.
- 9) Trace mode = max hold.
- 10) Allow max hold to run for at least 60 seconds, or longer as needed to allow the trace to stabilize.

For 26dB Bandwidth

- 1) Set RBW = approximately 1% of the emission bandwidth.
- 2) Set the VBW $>$ RBW.
- 3) Detector = Peak.
- 4) Trace mode = max hold.
- 5) Measure the maximum width of the emission that is 26 dB down from the peak of the emission. Compare this with the RBW setting of the analyzer. Readjust RBW and repeat measurement as needed until the RBW/EBW ratio is approximately 1%.

4.3.5 Deviation from Test Standard

No deviation.

4.3.6 EUT Operating Conditions

The software provided by client to enable the EUT under transmission condition continuously at lowest, middle and highest channel frequencies individually.

4.3.7 Test Result

Power Output:

Test Mode A, CDD Mode

For U-NII-1 Band

802.11a

Chan.	Freq. (MHz)	Maximum Conducted Power (dBm)		Total Power (mW)	Total Power (dBm)	Power Limit (dBm)	Gain (dBi)	EIRP (dBm)	EIRP Limit (dBm)	Pass / Fail
		Chain 0	Chain 1							
36	5180	18.42	19.05	149.855	21.76	29	-1	20.76	21	Pass
40	5200	18.76	18.87	152.252	21.83	29	-1	20.83	21	Pass
48	5240	19.22	18.41	152.903	21.84	29	-1	20.84	21	Pass

Note:

Gain = 7dBi > 6dBi, so the limit shall be reduced to $30 - (7 - 6) = 29$ dBm.

Gain = -1dBi (above 30 degrees from the horizon)

EIRP = conducted power + (-1dBi) + array gain (0dBi (i.e., no array gain) for $N_{ANT} \leq 4$)

802.11n (HT20)

Chan.	Freq. (MHz)	Maximum Conducted Power (dBm)		Total Power (mW)	Total Power (dBm)	Power Limit (dBm)	Gain (dBi)	EIRP (dBm)	EIRP Limit (dBm)	Pass / Fail
		Chain 0	Chain 1							
36	5180	18.75	18.92	152.972	21.85	29	-1	20.85	21	Pass
40	5200	18.69	18.76	149.123	21.74	29	-1	20.74	21	Pass
48	5240	19.32	18.37	154.214	21.88	29	-1	20.88	21	Pass

Note:

Gain = 7dBi > 6dBi, so the limit shall be reduced to $30 - (7 - 6) = 29$ dBm.

Gain = -1dBi (above 30 degrees from the horizon)

EIRP = conducted power + (-1dBi) + array gain (0dBi (i.e., no array gain) for $N_{ANT} \leq 4$)

802.11n (HT40)

Chan.	Freq. (MHz)	Maximum Conducted Power (dBm)		Total Power (mW)	Total Power (dBm)	Power Limit (dBm)	Gain (dBi)	EIRP (dBm)	EIRP Limit (dBm)	Pass / Fail
		Chain 0	Chain 1							
38	5190	15.31	15.44	68.958	18.39	29	-1	17.39	21	Pass
46	5230	18.64	18.56	144.893	21.61	29	-1	20.61	21	Pass

Note:

Gain = 7dBi > 6dBi, so the limit shall be reduced to $30 - (7 - 6) = 29$ dBm.

Gain = -1dBi (above 30 degrees from the horizon)

EIRP = conducted power + (-1dBi) + array gain (0dBi (i.e., no array gain) for $N_{ANT} \leq 4$)

802.11ac (VHT80)

Chan.	Freq. (MHz)	Maximum Conducted Power (dBm)		Total Power (mW)	Total Power (dBm)	Power Limit (dBm)	Gain (dBi)	EIRP (dBm)	EIRP Limit (dBm)	Pass / Fail
		Chain 0	Chain 1							
42	5210	13.53	13.31	43.971	16.43	29	-1	15.43	21	Pass

Note:

Gain = 7dBi > 6dBi, so the limit shall be reduced to $30 - (7 - 6) = 29$ dBm.

Gain = -1dBi (above 30 degrees from the horizon)

EIRP = conducted power + (-1dBi) + array gain (0dBi (i.e., no array gain) for $N_{ANT} \leq 4$)

For U-NII-3 Band

802.11a

Chan.	Freq. (MHz)	Maximum Conducted Power (dBm)		Total Power (mW)	Total Power (dBm)	Power Limit (dBm)	Pass / Fail
		Chain 0	Chain 1				
149	5745	22.37	21.37	309.672	24.91	29	Pass
157	5785	21.81	21.45	291.342	24.64	29	Pass
165	5825	21.44	21.89	293.841	24.68	29	Pass

Note: Gain = 7dBi > 6dBi, so the limit shall be reduced to 30-(7-6) = 29dBm.

802.11n (HT20)

Chan.	Freq. (MHz)	Maximum Conducted Power (dBm)		Total Power (mW)	Total Power (dBm)	Power Limit (dBm)	Pass / Fail
		Chain 0	Chain 1				
149	5745	21.64	21.36	282.654	24.51	29	Pass
157	5785	21.24	21.42	271.721	24.34	29	Pass
165	5825	21.42	22.03	298.264	24.75	29	Pass

Note: Gain = 7dBi > 6dBi, so the limit shall be reduced to 30-(7-6) = 29dBm.

802.11n (HT40)

Chan.	Freq. (MHz)	Maximum Conducted Power (dBm)		Total Power (mW)	Total Power (dBm)	Power Limit (dBm)	Pass / Fail
		Chain 0	Chain 1				
151	5755	21.88	21.58	298.05	24.74	29	Pass
159	5795	22.22	21.94	323.04	25.09	29	Pass

Note: Gain = 7dBi > 6dBi, so the limit shall be reduced to 30-(7-6) = 29dBm.

802.11ac (VHT80)

Chan.	Freq. (MHz)	Maximum Conducted Power (dBm)		Total Power (mW)	Total Power (dBm)	Power Limit (dBm)	Pass / Fail
		Chain 0	Chain 1				
155	5775	16.67	16.62	92.372	19.66	29	Pass

Note: Gain = 7dBi > 6dBi, so the limit shall be reduced to 30-(7-6) = 29dBm.

Test Mode A, Beamforming Mode

For U-NII-1 Band

802.11n (HT20)

Chan.	Freq. (MHz)	Maximum Conducted Power (dBm)		Total Power (mW)	Total Power (dBm)	Power Limit (dBm)	Gain (dBi)	EIRP (dBm)	EIRP Limit (dBm)	Pass / Fail
		Chain 0	Chain 1							
36	5180	15.74	15.91	76.491	18.84	25.99	2.01	20.85	21	Pass
40	5200	15.68	15.75	74.567	18.73	25.99	2.01	20.74	21	Pass
48	5240	16.31	15.36	77.112	18.87	25.99	2.01	20.88	21	Pass

Note:

Gain = 7dBi + array gain (3.01dBi) > 6dBi, so the limit shall be reduced to 30-(10.01-6) = 25.99dBm.

Gain = -1dBi (above 30 degrees from the horizon)

EIRP = conducted power + (-1dBi) + beamforming gain (3.01dBi)

802.11n (HT40)

Chan.	Freq. (MHz)	Maximum Conducted Power (dBm)		Total Power (mW)	Total Power (dBm)	Power Limit (dBm)	Gain (dBi)	EIRP (dBm)	EIRP Limit (dBm)	Pass / Fail
		Chain 0	Chain 1							
38	5190	12.30	12.43	34.480	15.38	25.99	2.01	17.39	21	Pass
46	5230	15.63	15.55	72.451	18.60	25.99	2.01	20.61	21	Pass

Note:

Gain = 7dBi + array gain (3.01dBi) > 6dBi, so the limit shall be reduced to 30-(10.01-6) = 25.99dBm.

Gain = -1dBi (above 30 degrees from the horizon)

EIRP = conducted power + (-1dBi) + beamforming gain (3.01dBi)

802.11ac (VHT80)

Chan.	Freq. (MHz)	Maximum Conducted Power (dBm)		Total Power (mW)	Total Power (dBm)	Power Limit (dBm)	Gain (dBi)	EIRP (dBm)	EIRP Limit (dBm)	Pass / Fail
		Chain 0	Chain 1							
42	5210	10.52	10.30	21.987	13.42	25.99	2.01	15.43	21	Pass

Note:

Gain = 7dBi + array gain (3.01dBi) > 6dBi, so the limit shall be reduced to 30-(10.01-6) = 25.99dBm.

Gain = -1dBi (above 30 degrees from the horizon)

EIRP = conducted power + (-1dBi) + beamforming gain (3.01dBi)

For U-NII-3 Band

802.11n (HT20)

Chan.	Freq. (MHz)	Maximum Conducted Power (dBm)		Total Power (mW)	Total Power (dBm)	Power Limit (dBm)	Pass / Fail
		Chain 0	Chain 1				
149	5745	18.63	18.35	141.337	21.50	25.99	Pass
157	5785	18.23	18.41	135.870	21.33	25.99	Pass
165	5825	18.41	19.02	149.142	21.74	25.99	Pass

Note: Gain = 7dBi + array gain (3.01dBi) > 6dBi, so the limit shall be reduced to 30-(10.01-6) = 25.99dBm.

802.11n (HT40)

Chan.	Freq. (MHz)	Maximum Conducted Power (dBm)		Total Power (mW)	Total Power (dBm)	Power Limit (dBm)	Pass / Fail
		Chain 0	Chain 1				
151	5755	18.87	18.57	149.035	21.73	25.99	Pass
159	5795	19.21	18.93	161.531	22.08	25.99	Pass

Note: Gain = 7dBi + array gain (3.01dBi) > 6dBi, so the limit shall be reduced to 30-(10.01-6) = 25.99dBm.

802.11ac (VHT80)

Chan.	Freq. (MHz)	Maximum Conducted Power (dBm)		Total Power (mW)	Total Power (dBm)	Power Limit (dBm)	Pass / Fail
		Chain 0	Chain 1				
155	5775	13.66	13.61	46.188	16.65	25.99	Pass

Note: Gain = 7dBi + array gain (3.01dBi) > 6dBi, so the limit shall be reduced to 30-(10.01-6) = 25.99dBm.

Test Mode B, CDD Mode

For U-NII-1 Band

802.11a

Chan.	Freq. (MHz)	Maximum Conducted Power (dBm)		Total Power (mW)	Total Power (dBm)	Power Limit (dBm)	Gain (dBi)	EIRP (dBm)	EIRP Limit (dBm)	Pass / Fail
		Chain 0	Chain 1							
36	5180	6.66	6.71	9.322	9.70	23	11.2	20.90	21	Pass
40	5200	6.42	6.76	9.127	9.60	23	11.2	20.80	21	Pass
48	5240	7.12	6.31	9.428	9.74	23	11.2	20.94	21	Pass

Note:

Gain = 13dBi > 6dBi, so the limit shall be reduced to 30-(13-6) = 23dBm.

Gain = 11.2dBi (above 30 degrees from the horizon)

EIRP = conducted power + (11.2dBi) + array gain (0dBi (i.e., no array gain) for $N_{ANT} \leq 4$)

802.11n (HT20)

Chan.	Freq. (MHz)	Maximum Conducted Power (dBm)		Total Power (mW)	Total Power (dBm)	Power Limit (dBm)	Gain (dBi)	EIRP (dBm)	EIRP Limit (dBm)	Pass / Fail
		Chain 0	Chain 1							
36	5180	6.59	6.89	9.447	9.75	23	11.2	20.95	21	Pass
40	5200	6.75	6.61	9.313	9.69	23	11.2	20.89	21	Pass
48	5240	6.93	6.39	9.287	9.68	23	11.2	20.88	21	Pass

Note:

Gain = 13dBi > 6dBi, so the limit shall be reduced to 30-(13-6) = 23dBm.

Gain = 11.2dBi (above 30 degrees from the horizon)

EIRP = conducted power + (11.2dBi) + array gain (0dBi (i.e., no array gain) for $N_{ANT} \leq 4$)

802.11n (HT40)

Chan.	Freq. (MHz)	Maximum Conducted Power (dBm)		Total Power (mW)	Total Power (dBm)	Power Limit (dBm)	Gain (dBi)	EIRP (dBm)	EIRP Limit (dBm)	Pass / Fail
		Chain 0	Chain 1							
38	5190	6.77	6.72	9.452	9.76	23	11.2	20.96	21	Pass
46	5230	7.02	6.53	9.533	9.79	23	11.2	20.99	21	Pass

Note:

Gain = 13dBi > 6dBi, so the limit shall be reduced to 30-(13-6) = 23dBm.

Gain = 11.2dBi (above 30 degrees from the horizon)

EIRP = conducted power + (11.2dBi) + array gain (0dBi (i.e., no array gain) for $N_{ANT} \leq 4$)

802.11ac (VHT80)

Chan.	Freq. (MHz)	Maximum Conducted Power (dBm)		Total Power (mW)	Total Power (dBm)	Power Limit (dBm)	Gain (dBi)	EIRP (dBm)	EIRP Limit (dBm)	Pass / Fail
		Chain 0	Chain 1							
42	5210	7.06	6.45	9.498	9.78	23	11.2	20.98	21	Pass

Note:

Gain = 13dBi > 6dBi, so the limit shall be reduced to 30-(13-6) = 23dBm.

Gain = 11.2dBi (above 30 degrees from the horizon)

EIRP = conducted power + (11.2dBi) + array gain (0dBi (i.e., no array gain) for $N_{ANT} \leq 4$)

For U-NII-3 Band

802.11a

Chan.	Freq. (MHz)	Maximum Conducted Power (dBm)		Total Power (mW)	Total Power (dBm)	Power Limit (dBm)	Pass / Fail
		Chain 0	Chain 1				
149	5745	20.02	19.01	180.078	22.55	23	Pass
157	5785	19.93	18.88	175.669	22.45	23	Pass
165	5825	20.01	19.15	182.455	22.61	23	Pass

Note: Gain = 13dBi > 6dBi, so the limit shall be reduced to 30-(13-6) = 23dBm.

802.11n (HT20)

Chan.	Freq. (MHz)	Maximum Conducted Power (dBm)		Total Power (mW)	Total Power (dBm)	Power Limit (dBm)	Pass / Fail
		Chain 0	Chain 1				
149	5745	19.94	19.00	178.061	22.51	23	Pass
157	5785	19.91	19.05	178.302	22.51	23	Pass
165	5825	19.95	19.22	182.415	22.61	23	Pass

Note: Gain = 13dBi > 6dBi, so the limit shall be reduced to 30-(13-6) = 23dBm.

802.11n (HT40)

Chan.	Freq. (MHz)	Maximum Conducted Power (dBm)		Total Power (mW)	Total Power (dBm)	Power Limit (dBm)	Pass / Fail
		Chain 0	Chain 1				
151	5755	20.12	19.12	184.460	22.66	23	Pass
159	5795	20.14	19.07	184.000	22.65	23	Pass

Note: Gain = 13dBi > 6dBi, so the limit shall be reduced to 30-(13-6) = 23dBm.

802.11ac (VHT80)

Chan.	Freq. (MHz)	Maximum Conducted Power (dBm)		Total Power (mW)	Total Power (dBm)	Power Limit (dBm)	Pass / Fail
		Chain 0	Chain 1				
155	5775	16.92	16.23	91.180	19.60	23	Pass

Note: Gain = 13dBi > 6dBi, so the limit shall be reduced to 30-(13-6) = 23dBm.

Test Mode B, Beamforming Mode

For U-NII-1 Band

802.11n (HT20)

Chan.	Freq. (MHz)	Maximum Conducted Power (dBm)		Total Power (mW)	Total Power (dBm)	Power Limit (dBm)	Gain (dBi)	EIRP (dBm)	EIRP Limit (dBm)	Pass / Fail
		Chain 0	Chain 1							
36	5180	3.58	3.88	4.723	6.74	19.99	14.21	20.95	21	Pass
40	5200	3.74	3.60	4.657	6.68	19.99	14.21	20.89	21	Pass
48	5240	3.92	3.38	4.644	6.67	19.99	14.21	20.88	21	Pass

Note:

Gain = 13dBi + array gain (3.01dBi) > 6dBi, so the limit shall be reduced to 30-(16.01-6) = 19.99dBm.

Gain = 11.2dBi (above 30 degrees from the horizon)

EIRP = conducted power + (11.2dBi) + beamforming gain (3.01dBi)

802.11n (HT40)

Chan.	Freq. (MHz)	Maximum Conducted Power (dBm)		Total Power (mW)	Total Power (dBm)	Power Limit (dBm)	Gain (dBi)	EIRP (dBm)	EIRP Limit (dBm)	Pass / Fail
		Chain 0	Chain 1							
38	5190	3.76	3.71	4.727	6.75	19.99	14.21	20.96	21	Pass
46	5230	4.01	3.52	4.767	6.78	19.99	14.21	20.99	21	Pass

Note:

Gain = 13dBi + array gain (3.01dBi) > 6dBi, so the limit shall be reduced to 30-(16.01-6) = 19.99dBm.

Gain = 11.2dBi (above 30 degrees from the horizon)

EIRP = conducted power + (11.2dBi) + beamforming gain (3.01dBi)

802.11ac (VHT80)

Chan.	Freq. (MHz)	Maximum Conducted Power (dBm)		Total Power (mW)	Total Power (dBm)	Power Limit (dBm)	Gain (dBi)	EIRP (dBm)	EIRP Limit (dBm)	Pass / Fail
		Chain 0	Chain 1							
42	5210	4.05	3.44	4.749	6.77	19.99	14.21	20.98	21	Pass

Note:

Gain = 13dBi + array gain (3.01dBi) > 6dBi, so the limit shall be reduced to 30-(16.01-6) = 19.99dBm.

Gain = 11.2dBi (above 30 degrees from the horizon)

EIRP = conducted power + (11.2dBi) + beamforming gain (3.01dBi)

For U-NII-3 Band

802.11n (HT20)

Chan.	Freq. (MHz)	Maximum Conducted Power (dBm)		Total Power (mW)	Total Power (dBm)	Power Limit (dBm)	Pass / Fail
		Chain 0	Chain 1				
149	5745	16.93	15.99	89.036	19.50	19.99	Pass
157	5785	16.90	16.04	89.157	19.50	19.99	Pass
165	5825	16.94	16.21	91.214	19.60	19.99	Pass

Note: Gain = 13dBi + array gain (3.01dBi) > 6dBi, so the limit shall be reduced to 30-(16.01-6) = 19.99dBm.

802.11n (HT40)

Chan.	Freq. (MHz)	Maximum Conducted Power (dBm)		Total Power (mW)	Total Power (dBm)	Power Limit (dBm)	Pass / Fail
		Chain 0	Chain 1				
151	5755	17.11	16.11	92.236	19.65	19.99	Pass
159	5795	17.13	16.06	92.007	19.64	19.99	Pass

Note: Gain = 13dBi + array gain (3.01dBi) > 6dBi, so the limit shall be reduced to 30-(16.01-6) = 19.99dBm.

802.11ac (VHT80)

Chan.	Freq. (MHz)	Maximum Conducted Power (dBm)		Total Power (mW)	Total Power (dBm)	Power Limit (dBm)	Pass / Fail
		Chain 0	Chain 1				
155	5775	13.91	13.22	45.593	16.59	19.99	Pass

Note: Gain = 13dBi + array gain (3.01dBi) > 6dBi, so the limit shall be reduced to 30-(16.01-6) = 19.99dBm.

Test Mode C, CDD Mode

For U-NII-1 Band

802.11a

Chan.	Freq. (MHz)	Maximum Conducted Power (dBm)		Total Power (mW)	Total Power (dBm)	Power Limit (dBm)	Gain (dBi)	EIRP (dBm)	EIRP Limit (dBm)	Pass / Fail
		Chain 0	Chain 1							
36	5180	16.09	15.94	79.908	19.03	28.90	1.8	20.83	21	Pass
40	5200	16.04	15.89	78.994	18.98	28.90	1.8	20.78	21	Pass
48	5240	16.49	15.72	81.891	19.13	28.90	1.8	20.93	21	Pass

Note:

Gain = 7.1dBi > 6dBi, so the limit shall be reduced to $30-(7.1-6) = 28.90\text{dBm}$.

Gain = 1.8dBi (above 30 degrees from the horizon)

EIRP = conducted power + (1.8dBi) + array gain (0dBi (i.e., no array gain) for $N_{\text{ANT}} \leq 4$)

802.11n (HT20)

Chan.	Freq. (MHz)	Maximum Conducted Power (dBm)		Total Power (mW)	Total Power (dBm)	Power Limit (dBm)	Gain (dBi)	EIRP (dBm)	EIRP Limit (dBm)	Pass / Fail
		Chain 0	Chain 1							
36	5180	16.24	15.92	81.157	19.09	28.90	1.8	20.89	21	Pass
40	5200	16.33	15.81	81.061	19.09	28.90	1.8	20.89	21	Pass
48	5240	16.58	15.68	82.482	19.16	28.90	1.8	20.96	21	Pass

Note:

Gain = 7.1dBi > 6dBi, so the limit shall be reduced to $30-(7.1-6) = 28.90\text{dBm}$.

Gain = 1.8dBi (above 30 degrees from the horizon)

EIRP = conducted power + (1.8dBi) + array gain (0dBi (i.e., no array gain) for $N_{\text{ANT}} \leq 4$)

802.11n (HT40)

Chan.	Freq. (MHz)	Maximum Conducted Power (dBm)		Total Power (mW)	Total Power (dBm)	Power Limit (dBm)	Gain (dBi)	EIRP (dBm)	EIRP Limit (dBm)	Pass / Fail
		Chain 0	Chain 1							
38	5190	15.77	15.55	73.649	18.67	28.90	1.8	20.47	21	Pass
46	5230	16.01	15.44	74.897	18.74	28.90	1.8	20.54	21	Pass

Note:

Gain = 7.1dBi > 6dBi, so the limit shall be reduced to $30-(7.1-6) = 28.90\text{dBm}$.

Gain = 1.8dBi (above 30 degrees from the horizon)

EIRP = conducted power + (1.8dBi) + array gain (0dBi (i.e., no array gain) for $N_{\text{ANT}} \leq 4$)

802.11ac (VHT80)

Chan.	Freq. (MHz)	Maximum Conducted Power (dBm)		Total Power (mW)	Total Power (dBm)	Power Limit (dBm)	Gain (dBi)	EIRP (dBm)	EIRP Limit (dBm)	Pass / Fail
		Chain 0	Chain 1							
42	5210	15.80	15.42	72.853	18.62	28.90	1.8	20.42	21	Pass

Note:

Gain = 7.1dBi > 6dBi, so the limit shall be reduced to $30-(7.1-6) = 28.90\text{dBm}$.

Gain = 1.8dBi (above 30 degrees from the horizon)

EIRP = conducted power + (1.8dBi) + array gain (0dBi (i.e., no array gain) for $N_{\text{ANT}} \leq 4$)

For U-NII-3 Band

802.11a

Chan.	Freq. (MHz)	Maximum Conducted Power (dBm)		Total Power (mW)	Total Power (dBm)	Power Limit (dBm)	Pass / Fail
		Chain 0	Chain 1				
149	5745	22.87	21.74	342.921	25.35	28.90	Pass
157	5785	22.38	21.65	319.200	25.04	28.90	Pass
165	5825	22.18	21.67	312.089	24.94	28.90	Pass

Note: Gain = 7.1dBi > 6dBi, so the limit shall be reduced to $30-(7.1-6) = 28.90\text{dBm}$.

802.11n (HT20)

Chan.	Freq. (MHz)	Maximum Conducted Power (dBm)		Total Power (mW)	Total Power (dBm)	Power Limit (dBm)	Pass / Fail
		Chain 0	Chain 1				
149	5745	22.83	21.62	337.078	25.28	28.90	Pass
157	5785	22.15	21.34	300.203	24.77	28.90	Pass
165	5825	22.23	21.60	311.653	24.94	28.90	Pass

Note: Gain = 7.1dBi > 6dBi, so the limit shall be reduced to $30-(7.1-6) = 28.90\text{dBm}$.

802.11n (HT40)

Chan.	Freq. (MHz)	Maximum Conducted Power (dBm)		Total Power (mW)	Total Power (dBm)	Power Limit (dBm)	Pass / Fail
		Chain 0	Chain 1				
151	5755	22.68	21.56	328.572	25.17	28.90	Pass
159	5795	22.22	21.94	323.040	25.09	28.90	Pass

Note: Gain = 7.1dBi > 6dBi, so the limit shall be reduced to $30-(7.1-6) = 28.90\text{dBm}$.

802.11ac (VHT80)

Chan.	Freq. (MHz)	Maximum Conducted Power (dBm)		Total Power (mW)	Total Power (dBm)	Power Limit (dBm)	Pass / Fail
		Chain 0	Chain 1				
155	5775	19.08	17.96	143.427	21.57	28.90	Pass

Note: Gain = 7.1dBi > 6dBi, so the limit shall be reduced to $30-(7.1-6) = 28.90\text{dBm}$.

Test Mode C, Beamforming Mode

For U-NII-1 Band

802.11n (HT20)

Chan.	Freq. (MHz)	Maximum Conducted Power (dBm)		Total Power (mW)	Total Power (dBm)	Power Limit (dBm)	Gain (dBi)	EIRP (dBm)	EIRP Limit (dBm)	Pass / Fail
		Chain 0	Chain 1							
36	5180	13.23	12.91	40.581	16.08	25.89	4.81	20.89	21	Pass
40	5200	13.32	12.80	40.533	16.08	25.89	4.81	20.89	21	Pass
48	5240	13.57	12.67	41.244	16.15	25.89	4.81	20.96	21	Pass

Note:

Gain = 7.1dBi + array gain (3.01dBi) > 6dBi, so the limit shall be reduced to 30-(10.11-6) = 25.89dBm.

Gain = 1.8dBi (above 30 degrees from the horizon)

EIRP = conducted power + (1.8dBi) + beamforming gain (3.01dBi)

802.11n (HT40)

Chan.	Freq. (MHz)	Maximum Conducted Power (dBm)		Total Power (mW)	Total Power (dBm)	Power Limit (dBm)	Gain (dBi)	EIRP (dBm)	EIRP Limit (dBm)	Pass / Fail
		Chain 0	Chain 1							
38	5190	12.76	12.54	36.827	15.66	25.89	4.81	20.47	21	Pass
46	5230	13.00	12.43	37.451	15.73	25.89	4.81	20.54	21	Pass

Note:

Gain = 7.1dBi + array gain (3.01dBi) > 6dBi, so the limit shall be reduced to 30-(10.11-6) = 25.89dBm.

Gain = 1.8dBi (above 30 degrees from the horizon)

EIRP = conducted power + (1.8dBi) + beamforming gain (3.01dBi)

802.11ac (VHT80)

Chan.	Freq. (MHz)	Maximum Conducted Power (dBm)		Total Power (mW)	Total Power (dBm)	Power Limit (dBm)	Gain (dBi)	EIRP (dBm)	EIRP Limit (dBm)	Pass / Fail
		Chain 0	Chain 1							
42	5210	12.79	12.41	36.429	15.61	25.89	4.81	20.42	21	Pass

Note:

Gain = 7.1dBi + array gain (3.01dBi) > 6dBi, so the limit shall be reduced to 30-(10.11-6) = 25.89dBm.

Gain = 1.8dBi (above 30 degrees from the horizon)

EIRP = conducted power + (1.8dBi) + beamforming gain (3.01dBi)

For U-NII-3 Band

802.11n (HT20)

Chan.	Freq. (MHz)	Maximum Conducted Power (dBm)		Total Power (mW)	Total Power (dBm)	Power Limit (dBm)	Pass / Fail
		Chain 0	Chain 1				
149	5745	19.82	18.61	168.551	22.27	25.89	Pass
157	5785	19.14	18.33	150.112	21.76	25.89	Pass
165	5825	19.22	18.59	155.837	21.93	25.89	Pass

Note: Gain = 7.1dBi + array gain (3.01dBi) > 6dBi, so the limit shall be reduced to 30-(10.11-6) = 25.89dBm.

802.11n (HT40)

Chan.	Freq. (MHz)	Maximum Conducted Power (dBm)		Total Power (mW)	Total Power (dBm)	Power Limit (dBm)	Pass / Fail
		Chain 0	Chain 1				
151	5755	19.67	18.55	164.297	22.16	25.89	Pass
159	5795	19.21	18.93	161.531	22.08	25.89	Pass

Note: Gain = 7.1dBi + array gain (3.01dBi) > 6dBi, so the limit shall be reduced to 30-(10.11-6) = 25.89dBm.

802.11ac (VHT80)

Chan.	Freq. (MHz)	Maximum Conducted Power (dBm)		Total Power (mW)	Total Power (dBm)	Power Limit (dBm)	Pass / Fail
		Chain 0	Chain 1				
155	5775	16.07	14.95	71.719	18.56	25.89	Pass

Note: Gain = 7.1dBi + array gain (3.01dBi) > 6dBi, so the limit shall be reduced to 30-(10.11-6) = 25.89dBm.

Test Mode D, CDD Mode

For U-NII-1 Band

802.11a

Chan.	Freq. (MHz)	Maximum Conducted Power (dBm)		Total Power (mW)	Total Power (dBm)	Power Limit (dBm)	Gain (dBi)	EIRP (dBm)	EIRP Limit (dBm)	Pass / Fail
		Chain 0	Chain 1							
36	5180	8.13	8.11	12.972	11.13	24.70	9.7	20.83	21	Pass
40	5200	8.24	8.02	13.007	11.14	24.70	9.7	20.84	21	Pass
48	5240	8.34	8.01	13.147	11.19	24.70	9.7	20.89	21	Pass

Note:

Gain = 11.3dBi > 6dBi, so the limit shall be reduced to 30-(11.3-6) = 24.70dBm.

Gain = 9.7dBi (above 30 degrees from the horizon)

EIRP = conducted power + (9.7dBi) + array gain (0dBi (i.e., no array gain) for $N_{ANT} \leq 4$)

802.11n (HT20)

Chan.	Freq. (MHz)	Maximum Conducted Power (dBm)		Total Power (mW)	Total Power (dBm)	Power Limit (dBm)	Gain (dBi)	EIRP (dBm)	EIRP Limit (dBm)	Pass / Fail
		Chain 0	Chain 1							
36	5180	8.27	8.10	13.171	11.20	24.70	9.7	20.90	21	Pass
40	5200	8.22	8.03	12.990	11.14	24.70	9.7	20.84	21	Pass
48	5240	8.37	8.09	13.313	11.24	24.70	9.7	20.94	21	Pass

Note:

Gain = 11.3dBi > 6dBi, so the limit shall be reduced to 30-(11.3-6) = 24.70dBm.

Gain = 9.7dBi (above 30 degrees from the horizon)

EIRP = conducted power + (9.7dBi) + array gain (0dBi (i.e., no array gain) for $N_{ANT} \leq 4$)

802.11n (HT40)

Chan.	Freq. (MHz)	Maximum Conducted Power (dBm)		Total Power (mW)	Total Power (dBm)	Power Limit (dBm)	Gain (dBi)	EIRP (dBm)	EIRP Limit (dBm)	Pass / Fail
		Chain 0	Chain 1							
38	5190	8.26	8.19	13.291	11.24	24.70	9.7	20.94	21	Pass
46	5230	8.18	7.79	12.589	11.00	24.70	9.7	20.70	21	Pass

Note:

Gain = 11.3dBi > 6dBi, so the limit shall be reduced to 30-(11.3-6) = 24.70dBm.

Gain = 9.7dBi (above 30 degrees from the horizon)

EIRP = conducted power + (9.7dBi) + array gain (0dBi (i.e., no array gain) for $N_{ANT} \leq 4$)

802.11ac (VHT80)

Chan.	Freq. (MHz)	Maximum Conducted Power (dBm)		Total Power (mW)	Total Power (dBm)	Power Limit (dBm)	Gain (dBi)	EIRP (dBm)	EIRP Limit (dBm)	Pass / Fail
		Chain 0	Chain 1							
42	5210	8.00	7.77	12.294	10.90	24.70	9.7	20.60	21	Pass

Note:

Gain = 11.3dBi > 6dBi, so the limit shall be reduced to 30-(11.3-6) = 24.70dBm.

Gain = 9.7dBi (above 30 degrees from the horizon)

EIRP = conducted power + (9.7dBi) + array gain (0dBi (i.e., no array gain) for $N_{ANT} \leq 4$)

For U-NII-3 Band

802.11a

Chan.	Freq. (MHz)	Maximum Conducted Power (dBm)		Total Power (mW)	Total Power (dBm)	Power Limit (dBm)	Pass / Fail
		Chain 0	Chain 1				
149	5745	21.89	20.76	273.649	24.37	24.70	Pass
157	5785	21.82	20.55	265.556	24.24	24.70	Pass
165	5825	21.71	20.85	269.871	24.31	24.70	Pass

Note: Gain = 11.3dBi > 6dBi, so the limit shall be reduced to $30-(11.3-6) = 24.70$ dBm.

802.11n (HT20)

Chan.	Freq. (MHz)	Maximum Conducted Power (dBm)		Total Power (mW)	Total Power (dBm)	Power Limit (dBm)	Pass / Fail
		Chain 0	Chain 1				
149	5745	21.88	20.85	275.789	24.41	24.70	Pass
157	5785	21.64	20.71	263.642	24.21	24.70	Pass
165	5825	21.65	20.94	270.383	24.32	24.70	Pass

Note: Gain = 11.3dBi > 6dBi, so the limit shall be reduced to $30-(11.3-6) = 24.70$ dBm.

802.11n (HT40)

Chan.	Freq. (MHz)	Maximum Conducted Power (dBm)		Total Power (mW)	Total Power (dBm)	Power Limit (dBm)	Pass / Fail
		Chain 0	Chain 1				
151	5755	21.97	20.95	281.849	24.50	24.70	Pass
159	5795	21.95	20.92	280.270	24.48	24.70	Pass

Note: Gain = 11.3dBi > 6dBi, so the limit shall be reduced to $30-(11.3-6) = 24.70$ dBm.

802.11ac (VHT80)

Chan.	Freq. (MHz)	Maximum Conducted Power (dBm)		Total Power (mW)	Total Power (dBm)	Power Limit (dBm)	Pass / Fail
		Chain 0	Chain 1				
155	5775	17.21	16.08	93.153	19.69	24.70	Pass

Note: Gain = 11.3dBi > 6dBi, so the limit shall be reduced to $30-(11.3-6) = 24.70$ dBm.

Test Mode D, Beamforming Mode

For U-NII-1 Band

802.11n (HT20)

Chan.	Freq. (MHz)	Maximum Conducted Power (dBm)		Total Power (mW)	Total Power (dBm)	Power Limit (dBm)	Gain (dBi)	EIRP (dBm)	EIRP Limit (dBm)	Pass / Fail
		Chain 0	Chain 1							
36	5180	5.26	5.09	6.585	8.19	21.69	12.71	20.90	21	Pass
40	5200	5.21	5.02	6.496	8.13	21.69	12.71	20.84	21	Pass
48	5240	5.36	5.08	6.657	8.23	21.69	12.71	20.94	21	Pass

Note:

Gain = 11.3dBi + array gain (3.01dBi) > 6dBi, so the limit shall be reduced to 30-(14.31-6) = 21.69dBm.

Gain = 9.7dBi (above 30 degrees from the horizon)

EIRP = conducted power + (9.7dBi) + beamforming gain (3.01dBi)

802.11n (HT40)

Chan.	Freq. (MHz)	Maximum Conducted Power (dBm)		Total Power (mW)	Total Power (dBm)	Power Limit (dBm)	Gain (dBi)	EIRP (dBm)	EIRP Limit (dBm)	Pass / Fail
		Chain 0	Chain 1							
38	5190	5.25	5.18	6.646	8.23	21.69	12.71	20.94	21	Pass
46	5230	5.17	4.78	6.295	7.99	21.69	12.71	20.70	21	Pass

Note:

Gain = 11.3dBi + array gain (3.01dBi) > 6dBi, so the limit shall be reduced to 30-(14.31-6) = 21.69dBm.

Gain = 9.7dBi (above 30 degrees from the horizon)

EIRP = conducted power + (9.7dBi) + beamforming gain (3.01dBi)

802.11ac (VHT80)

Chan.	Freq. (MHz)	Maximum Conducted Power (dBm)		Total Power (mW)	Total Power (dBm)	Power Limit (dBm)	Gain (dBi)	EIRP (dBm)	EIRP Limit (dBm)	Pass / Fail
		Chain 0	Chain 1							
42	5210	4.99	4.76	6.147	7.89	21.69	12.71	20.60	21	Pass

Note:

Gain = 11.3dBi + array gain (3.01dBi) > 6dBi, so the limit shall be reduced to 30-(14.31-6) = 21.69dBm.

Gain = 9.7dBi (above 30 degrees from the horizon)

EIRP = conducted power + (9.7dBi) + beamforming gain (3.01dBi)

For U-NII-3 Band

802.11n (HT20)

Chan.	Freq. (MHz)	Maximum Conducted Power (dBm)		Total Power (mW)	Total Power (dBm)	Power Limit (dBm)	Pass / Fail
		Chain 0	Chain 1				
149	5745	18.87	17.84	137.904	21.40	21.69	Pass
157	5785	18.63	17.70	131.830	21.20	21.69	Pass
165	5825	18.64	17.93	135.201	21.31	21.69	Pass

Note: Gain = 11.3dBi + array gain (3.01dBi) > 6dBi, so the limit shall be reduced to 30-(14.31-6) = 21.69dBm.

802.11n (HT40)

Chan.	Freq. (MHz)	Maximum Conducted Power (dBm)		Total Power (mW)	Total Power (dBm)	Power Limit (dBm)	Pass / Fail
		Chain 0	Chain 1				
151	5755	18.96	17.94	140.935	21.49	21.69	Pass
159	5795	18.94	17.91	140.145	21.47	21.69	Pass

Note: Gain = 11.3dBi + array gain (3.01dBi) > 6dBi, so the limit shall be reduced to 30-(14.31-6) = 21.69dBm.

802.11ac (VHT80)

Chan.	Freq. (MHz)	Maximum Conducted Power (dBm)		Total Power (mW)	Total Power (dBm)	Power Limit (dBm)	Pass / Fail
		Chain 0	Chain 1				
155	5775	14.20	13.07	46.580	16.68	21.69	Pass

Note: Gain = 11.3dBi + array gain (3.01dBi) > 6dBi, so the limit shall be reduced to 30-(14.31-6) = 21.69dBm.

Test Mode E, CDD Mode

For U-NII-1 Band

802.11a

Chan.	Freq. (MHz)	Maximum Conducted Power (dBm)		Total Power (mW)	Total Power (dBm)	Power Limit (dBm)	Gain (dBi)	EIRP (dBm)	EIRP Limit (dBm)	Pass / Fail
		Chain 0	Chain 1							
36	5180	16.03	16.01	79.989	19.03	23	0.77	19.80	21	Pass
40	5200	16.12	16.04	81.105	19.09	23	0.77	19.86	21	Pass
48	5240	16.06	16.08	80.916	19.08	23	0.77	19.85	21	Pass

Note:

Gain = 13dBi > 6dBi, so the limit shall be reduced to 30-(13-6) = 23dBm.

Gain = 0.77dBi (above 30 degrees from the horizon)

EIRP = conducted power + (0.77dBi) + array gain (0dBi (i.e., no array gain) for $N_{ANT} \leq 4$)

802.11n (HT20)

Chan.	Freq. (MHz)	Maximum Conducted Power (dBm)		Total Power (mW)	Total Power (dBm)	Power Limit (dBm)	Gain (dBi)	EIRP (dBm)	EIRP Limit (dBm)	Pass / Fail
		Chain 0	Chain 1							
36	5180	16.13	16.02	81.014	19.09	23	0.77	19.86	21	Pass
40	5200	16.17	16.09	82.044	19.14	23	0.77	19.91	21	Pass
48	5240	16.34	16.05	83.325	19.21	23	0.77	19.98	21	Pass

Note:

Gain = 13dBi > 6dBi, so the limit shall be reduced to 30-(13-6) = 23dBm.

Gain = 0.77dBi (above 30 degrees from the horizon)

EIRP = conducted power + (0.77dBi) + array gain (0dBi (i.e., no array gain) for $N_{ANT} \leq 4$)

802.11n (HT40)

Chan.	Freq. (MHz)	Maximum Conducted Power (dBm)		Total Power (mW)	Total Power (dBm)	Power Limit (dBm)	Gain (dBi)	EIRP (dBm)	EIRP Limit (dBm)	Pass / Fail
		Chain 0	Chain 1							
38	5190	14.38	13.99	52.477	17.20	23	0.77	17.97	21	Pass
46	5230	17.45	16.84	103.896	20.17	23	0.77	20.94	21	Pass

Note:

Gain = 13dBi > 6dBi, so the limit shall be reduced to 30-(13-6) = 23dBm.

Gain = 0.77dBi (above 30 degrees from the horizon)

EIRP = conducted power + (0.77dBi) + array gain (0dBi (i.e., no array gain) for $N_{ANT} \leq 4$)

802.11ac (VHT80)

Chan.	Freq. (MHz)	Maximum Conducted Power (dBm)		Total Power (mW)	Total Power (dBm)	Power Limit (dBm)	Gain (dBi)	EIRP (dBm)	EIRP Limit (dBm)	Pass / Fail
		Chain 0	Chain 1							
42	5210	13.43	12.91	41.572	16.19	23	0.77	16.96	21	Pass

Note:

Gain = 13dBi > 6dBi, so the limit shall be reduced to 30-(13-6) = 23dBm.

Gain = 0.77dBi (above 30 degrees from the horizon)

EIRP = conducted power + (0.77dBi) + array gain (0dBi (i.e., no array gain) for $N_{ANT} \leq 4$)

For U-NII-3 Band

802.11a

Chan.	Freq. (MHz)	Maximum Conducted Power (dBm)		Total Power (mW)	Total Power (dBm)	Power Limit (dBm)	Pass / Fail
		Chain 0	Chain 1				
149	5745	20.02	19.01	180.078	22.55	23	Pass
157	5785	19.93	18.88	175.669	22.45	23	Pass
165	5825	19.10	18.04	144.963	21.61	23	Pass

Note: Gain = 13dBi > 6dBi, so the limit shall be reduced to 30-(13-6) = 23dBm.

802.11n (HT20)

Chan.	Freq. (MHz)	Maximum Conducted Power (dBm)		Total Power (mW)	Total Power (dBm)	Power Limit (dBm)	Pass / Fail
		Chain 0	Chain 1				
149	5745	19.94	19.00	178.061	22.51	23	Pass
157	5785	19.91	19.05	178.302	22.51	23	Pass
165	5825	19.95	19.22	182.415	22.61	23	Pass

Note: Gain = 13dBi > 6dBi, so the limit shall be reduced to 30-(13-6) = 23dBm.

802.11n (HT40)

Chan.	Freq. (MHz)	Maximum Conducted Power (dBm)		Total Power (mW)	Total Power (dBm)	Power Limit (dBm)	Pass / Fail
		Chain 0	Chain 1				
151	5755	20.12	19.12	184.460	22.66	23	Pass
159	5795	20.14	19.07	184.000	22.65	23	Pass

Note: Gain = 13dBi > 6dBi, so the limit shall be reduced to 30-(13-6) = 23dBm.

802.11ac (VHT80)

Chan.	Freq. (MHz)	Maximum Conducted Power (dBm)		Total Power (mW)	Total Power (dBm)	Power Limit (dBm)	Pass / Fail
		Chain 0	Chain 1				
155	5775	17.28	16.11	94.288	19.74	23	Pass

Note: Gain = 13dBi > 6dBi, so the limit shall be reduced to 30-(13-6) = 23dBm.

Test Mode E, Beamforming Mode

For U-NII-1 Band

802.11n (HT20)

Chan.	Freq. (MHz)	Maximum Conducted Power (dBm)		Total Power (mW)	Total Power (dBm)	Power Limit (dBm)	Gain (dBi)	EIRP (dBm)	EIRP Limit (dBm)	Pass / Fail
		Chain 0	Chain 1							
36	5180	13.12	13.01	40.511	16.08	19.99	3.78	19.86	21	Pass
40	5200	13.16	13.08	41.025	16.13	19.99	3.78	19.91	21	Pass
48	5240	13.33	13.04	41.665	16.20	19.99	3.78	19.98	21	Pass

Note:

Gain = 13dBi + array gain (3.01dBi) > 6dBi, so the limit shall be reduced to 30-(16.01-6) = 19.99dBm.

Gain = 0.77dBi (above 30 degrees from the horizon)

EIRP = conducted power + (0.77dBi) + beamforming gain (3.01dBi)

802.11n (HT40)

Chan.	Freq. (MHz)	Maximum Conducted Power (dBm)		Total Power (mW)	Total Power (dBm)	Power Limit (dBm)	Gain (dBi)	EIRP (dBm)	EIRP Limit (dBm)	Pass / Fail
		Chain 0	Chain 1							
38	5190	11.37	10.98	26.240	14.19	19.99	3.78	17.97	21	Pass
46	5230	14.44	13.83	51.952	17.16	19.99	3.78	20.94	21	Pass

Note:

Gain = 13dBi + array gain (3.01dBi) > 6dBi, so the limit shall be reduced to 30-(16.01-6) = 19.99dBm.

Gain = 0.77dBi (above 30 degrees from the horizon)

EIRP = conducted power + (0.77dBi) + beamforming gain (3.01dBi)

802.11ac (VHT80)

Chan.	Freq. (MHz)	Maximum Conducted Power (dBm)		Total Power (mW)	Total Power (dBm)	Power Limit (dBm)	Gain (dBi)	EIRP (dBm)	EIRP Limit (dBm)	Pass / Fail
		Chain 0	Chain 1							
42	5210	10.42	9.90	20.787	13.18	19.99	3.78	16.96	21	Pass

Note:

Gain = 13dBi + array gain (3.01dBi) > 6dBi, so the limit shall be reduced to 30-(16.01-6) = 19.99dBm.

Gain = 0.77dBi (above 30 degrees from the horizon)

EIRP = conducted power + (0.77dBi) + beamforming gain (3.01dBi)

For U-NII-3 Band

802.11n (HT20)

Chan.	Freq. (MHz)	Maximum Conducted Power (dBm)		Total Power (mW)	Total Power (dBm)	Power Limit (dBm)	Pass / Fail
		Chain 0	Chain 1				
149	5745	16.93	15.99	89.036	19.50	19.99	Pass
157	5785	16.90	16.04	89.157	19.50	19.99	Pass
165	5825	16.94	16.21	91.214	19.60	19.99	Pass

Note: Gain = 13dBi + array gain (3.01dBi) > 6dBi, so the limit shall be reduced to 30-(16.01-6) = 19.99dBm.

802.11n (HT40)

Chan.	Freq. (MHz)	Maximum Conducted Power (dBm)		Total Power (mW)	Total Power (dBm)	Power Limit (dBm)	Pass / Fail
		Chain 0	Chain 1				
151	5755	17.11	16.11	92.236	19.65	19.99	Pass
159	5795	17.13	16.06	92.007	19.64	19.99	Pass

Note: Gain = 13dBi + array gain (3.01dBi) > 6dBi, so the limit shall be reduced to 30-(16.01-6) = 19.99dBm.

802.11ac (VHT80)

Chan.	Freq. (MHz)	Maximum Conducted Power (dBm)		Total Power (mW)	Total Power (dBm)	Power Limit (dBm)	Pass / Fail
		Chain 0	Chain 1				
155	5775	14.27	13.10	47.147	16.73	19.99	Pass

Note: Gain = 13dBi + array gain (3.01dBi) > 6dBi, so the limit shall be reduced to 30-(16.01-6) = 19.99dBm.

Test Mode F

For U-NII-1 Band

802.11a

Chan.	Freq. (MHz)	Conducted Power (mW)	Conducted Power (dBm)	Power Limit (dBm)	Gain (dBi)	EIRP (dBm)	EIRP Limit (dBm)	Pass / Fail
36	5180	36.392	15.61	30	5.20	20.81	21	Pass
40	5200	37.757	15.77	30	5.20	20.97	21	Pass
48	5240	36.813	15.66	30	5.20	20.86	21	Pass

Note:

Gain = 5.20dBi < 6dBi, so the limit no need to be reduced.

Gain = 5.20dBi (above 30 degrees from the horizon)

EIRP = conducted power + (5.20dBi) + array gain = (0 dB (i.e., no array gain) for $N_{ANT} \leq 4$)

802.11n (HT20)

Chan.	Freq. (MHz)	Conducted Power (mW)	Conducted Power (dBm)	Power Limit (dBm)	Gain (dBi)	EIRP (dBm)	EIRP Limit (dBm)	Pass / Fail
36	5180	36.813	15.66	30	5.20	20.86	21	Pass
40	5200	36.308	15.60	30	5.20	20.80	21	Pass
48	5240	35.810	15.54	30	5.20	20.74	21	Pass

Note:

Gain = 5.20dBi < 6dBi, so the limit no need to be reduced.

Gain = 5.20dBi (above 30 degrees from the horizon)

EIRP = conducted power + (5.20dBi) + array gain = (0 dB (i.e., no array gain) for $N_{ANT} \leq 4$)

802.11n (HT40)

Chan.	Freq. (MHz)	Conducted Power (mW)	Conducted Power (dBm)	Power Limit (dBm)	Gain (dBi)	EIRP (dBm)	EIRP Limit (dBm)	Pass / Fail
36	5180	12.764	11.06	30	5.20	16.26	21	Pass
40	5200	37.068	15.69	30	5.20	20.89	21	Pass

Note:

Gain = 5.20dBi < 6dBi, so the limit no need to be reduced.

Gain = 5.20dBi (above 30 degrees from the horizon)

EIRP = conducted power + (5.20dBi) + array gain = (0 dB (i.e., no array gain) for $N_{ANT} \leq 4$)

802.11ac (VHT80)

Chan.	Freq. (MHz)	Conducted Power (mW)	Conducted Power (dBm)	Power Limit (dBm)	Gain (dBi)	EIRP (dBm)	EIRP Limit (dBm)	Pass / Fail
36	5180	9.311	9.69	30	5.20	14.89	21	Pass

Note:

Gain = 5.20dBi < 6dBi, so the limit no need to be reduced.

Gain = 5.20dBi (above 30 degrees from the horizon)

EIRP = conducted power + (5.20dBi) + array gain = (0 dB (i.e., no array gain) for $N_{ANT} \leq 4$)

For U-NII-3 Band

802.11a

Chan.	Freq. (MHz)	Maximum Conducted Power (mW)	Maximum Conducted Power (dBm)	Power Limit (dBm)	Pass / Fail
149	5745	66.988	18.26	30	Pass
157	5785	70.632	18.49	30	Pass
165	5825	67.143	18.27	30	Pass

Note: 5.20dBi < 6dBi, so the limit no need to be reduced.

802.11n (HT20)

Chan.	Freq. (MHz)	Maximum Conducted Power (mW)	Maximum Conducted Power (dBm)	Power Limit (dBm)	Pass / Fail
149	5745	68.234	18.34	30	Pass
157	5785	71.614	18.55	30	Pass
165	5825	64.863	18.12	30	Pass

Note: 5.20dBi < 6dBi, so the limit no need to be reduced.

802.11n (HT40)

Chan.	Freq. (MHz)	Maximum Conducted Power (mW)	Maximum Conducted Power (dBm)	Power Limit (dBm)	Pass / Fail
151	5755	65.615	18.17	30	Pass
159	5795	64.714	18.11	30	Pass

Note: 5.20dBi < 6dBi, so the limit no need to be reduced.

802.11ac (VHT80)

Chan.	Freq. (MHz)	Maximum Conducted Power (mW)	Maximum Conducted Power (dBm)	Power Limit (dBm)	Pass / Fail
155	5775	59.293	17.73	30	Pass

Note: 5.20dBi < 6dBi, so the limit no need to be reduced.

26dB Bandwidth

Test Mode A

802.11a

Channel	Frequency (MHz)	26dBc Bandwidth (MHz)	
		Chain 0	Chain 1
36	5180	19.52	19.23
40	5200	19.59	19.38
48	5240	19.46	19.37

802.11n (HT20)

Channel	Frequency (MHz)	26dBc Bandwidth (MHz)	
		Chain 0	Chain 1
36	5180	20.39	20.26
40	5200	20.36	20.34
48	5240	20.42	20.37

802.11n (HT40)

Channel	Frequency (MHz)	26dBc Bandwidth (MHz)	
		Chain 0	Chain 1
38	5190	40.65	40.83
46	5230	40.72	40.93

802.11ac (VHT80)

Channel	Frequency (MHz)	26dBc Bandwidth (MHz)	
		Chain 0	Chain 1
42	5210	83.96	84.01

Spectrum Plot of Worst Value

802.11a

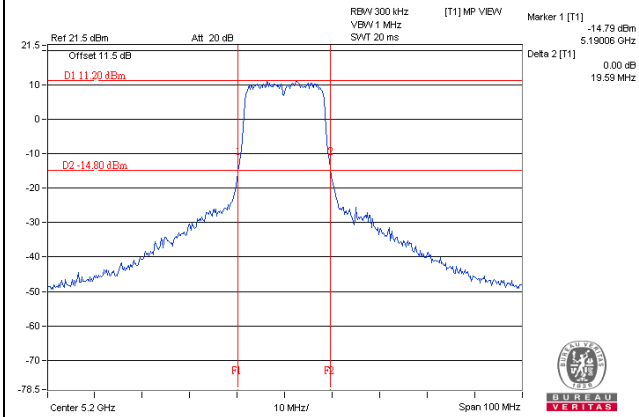

802.11n (HT20)

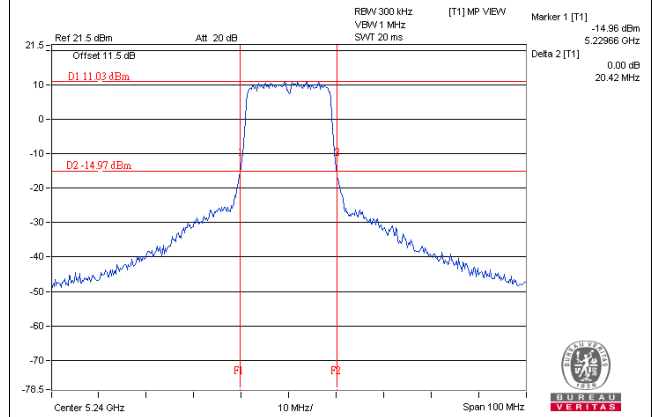

802.11n (HT40)

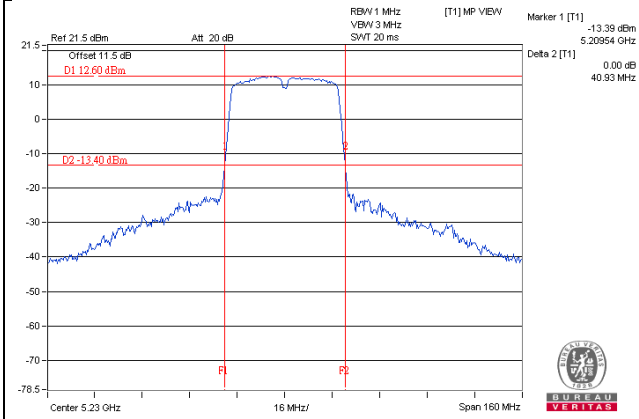

802.11ac (VHT80)

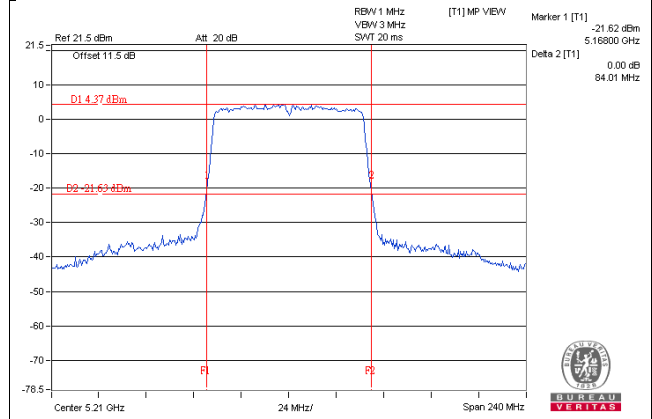

Test Mode B

802.11a

Channel	Frequency (MHz)	26dBc Bandwidth (MHz)	
		Chain 0	Chain 1
36	5180	19.39	19.16
40	5200	19.57	19.23
48	5240	19.57	19.27

802.11n (HT20)

Channel	Frequency (MHz)	26dBc Bandwidth (MHz)	
		Chain 0	Chain 1
36	5180	20.27	20.19
40	5200	20.29	20.29
48	5240	20.30	20.32

802.11n (HT40)

Channel	Frequency (MHz)	26dBc Bandwidth (MHz)	
		Chain 0	Chain 1
38	5190	40.59	40.83
46	5230	40.69	40.80

802.11ac (VHT80)

Channel	Frequency (MHz)	26dBc Bandwidth (MHz)	
		Chain 0	Chain 1
42	5210	84.16	84.19

Spectrum Plot of Worst Value

802.11a

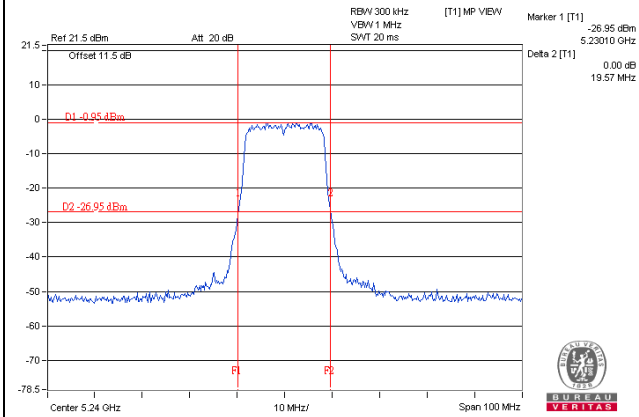

802.11n (HT20)

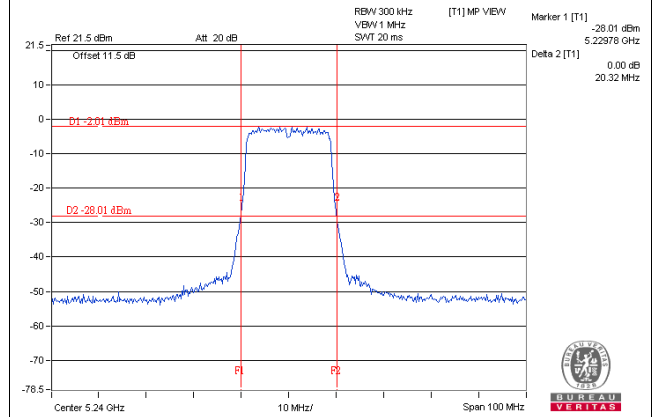

802.11n (HT40)

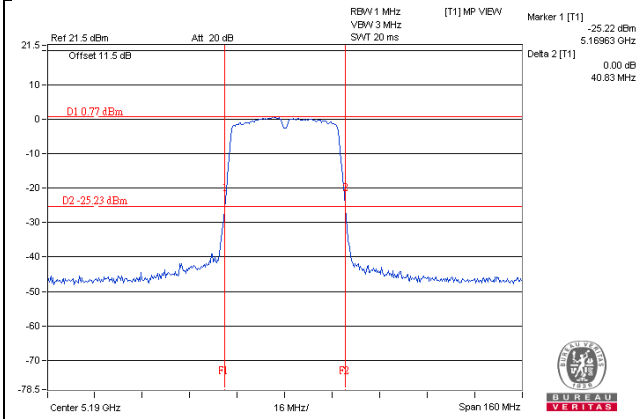

802.11ac (VHT80)

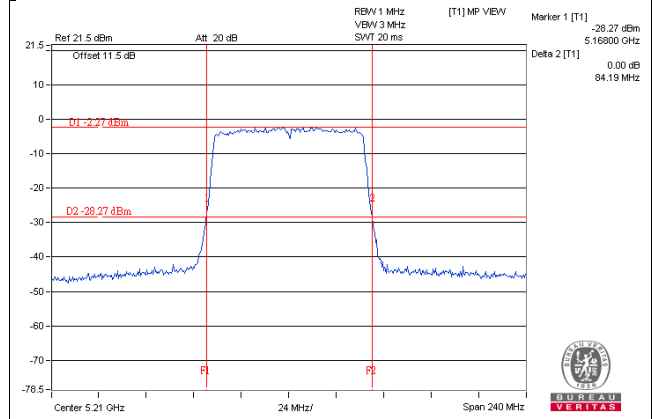

Test Mode C

802.11a

Channel	Frequency (MHz)	26dBc Bandwidth (MHz)	
		Chain 0	Chain 1
36	5180	19.65	19.31
40	5200	19.77	19.29
48	5240	19.71	19.48

802.11n (HT20)

Channel	Frequency (MHz)	26dBc Bandwidth (MHz)	
		Chain 0	Chain 1
36	5180	20.60	20.41
40	5200	20.55	20.40
48	5240	20.70	20.53

802.11n (HT40)

Channel	Frequency (MHz)	26dBc Bandwidth (MHz)	
		Chain 0	Chain 1
38	5190	40.69	40.63
46	5230	40.91	40.50

802.11ac (VHT80)

Channel	Frequency (MHz)	26dBc Bandwidth (MHz)	
		Chain 0	Chain 1
42	5210	83.82	84.36

Spectrum Plot of Worst Value

802.11a

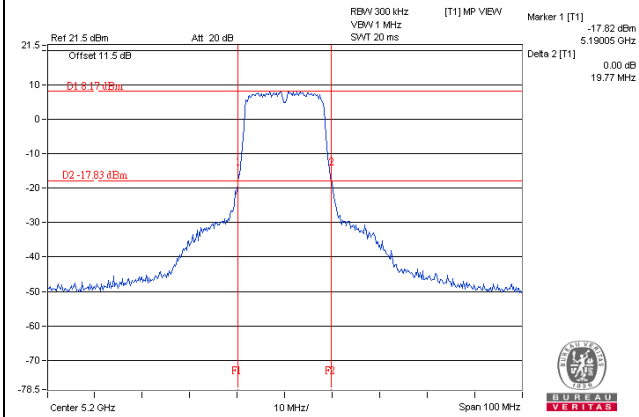

802.11n (HT20)

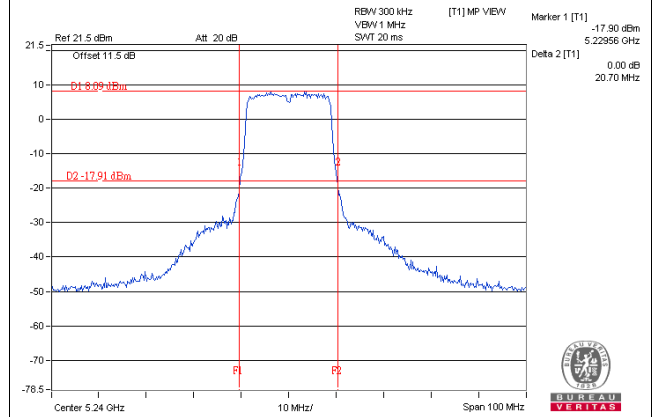

802.11n (HT40)

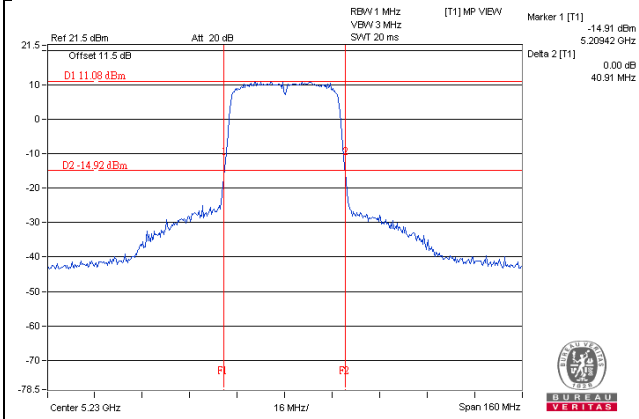

802.11ac (VHT80)

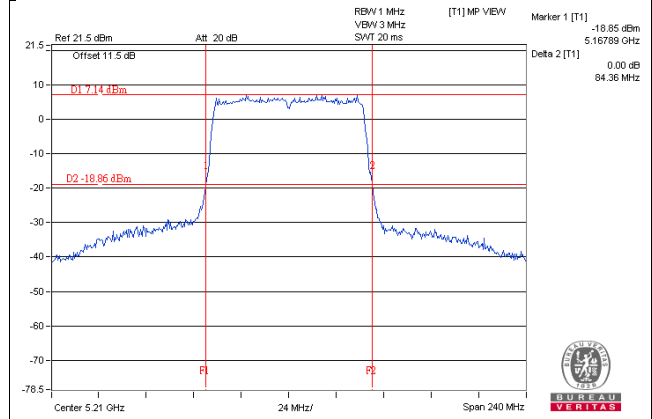

Test Mode D

802.11a

Channel	Frequency (MHz)	26dBc Bandwidth (MHz)	
		Chain 0	Chain 1
36	5180	19.44	19.23
40	5200	19.60	19.22
48	5240	19.63	19.23

802.11n (HT20)

Channel	Frequency (MHz)	26dBc Bandwidth (MHz)	
		Chain 0	Chain 1
36	5180	20.47	20.28
40	5200	20.49	20.37
48	5240	20.42	20.47

802.11n (HT40)

Channel	Frequency (MHz)	26dBc Bandwidth (MHz)	
		Chain 0	Chain 1
38	5190	40.47	40.50
46	5230	40.75	40.48

802.11ac (VHT80)

Channel	Frequency (MHz)	26dBc Bandwidth (MHz)	
		Chain 0	Chain 1
42	5210	84.53	82.99

Spectrum Plot of Worst Value

802.11a

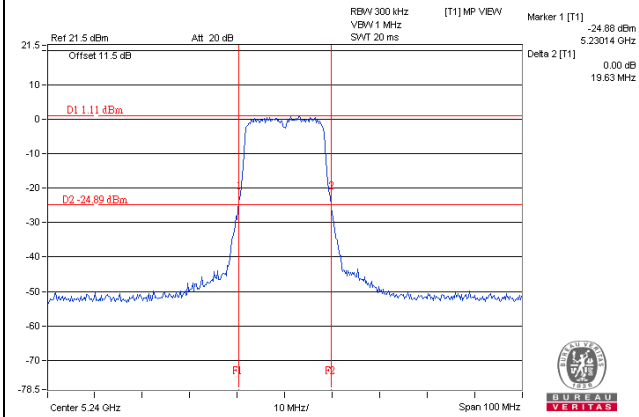

802.11n (HT20)

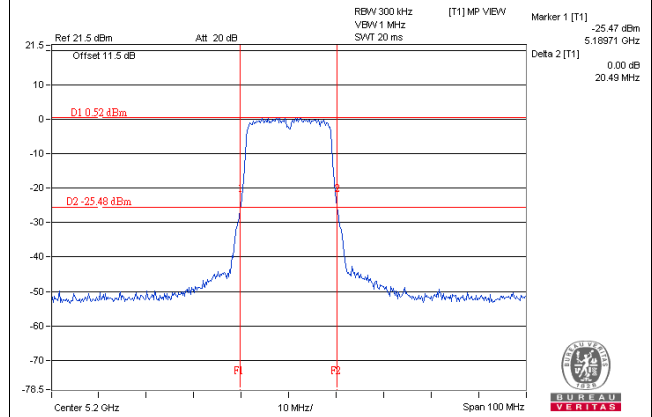

802.11n (HT40)

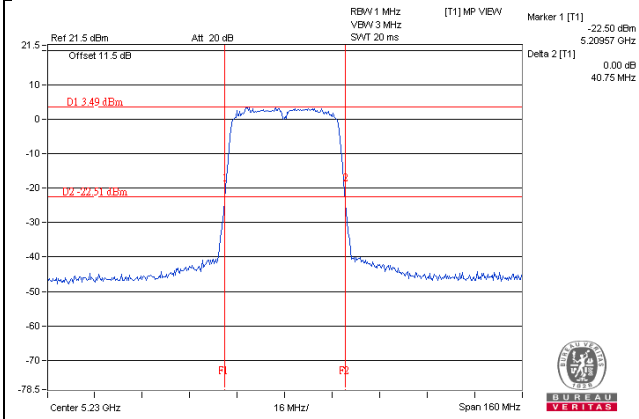

802.11ac (VHT80)

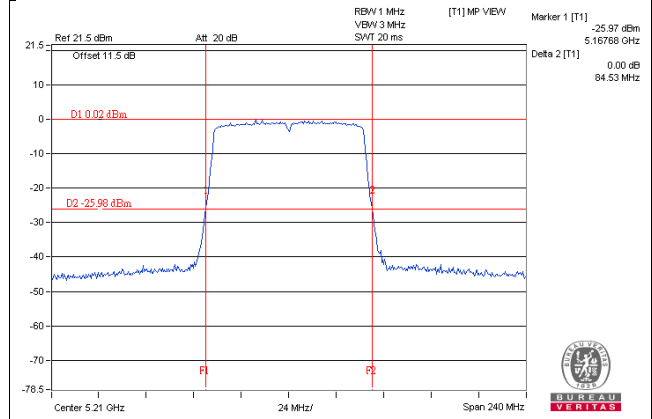

Test Mode E

802.11a

Channel	Frequency (MHz)	26dBc Bandwidth (MHz)	
		Chain 0	Chain 1
36	5180	19.47	19.27
40	5200	19.47	19.18
48	5240	19.68	19.46

802.11n (HT20)

Channel	Frequency (MHz)	26dBc Bandwidth (MHz)	
		Chain 0	Chain 1
36	5180	20.58	20.33
40	5200	20.43	20.42
48	5240	20.63	20.37

802.11n (HT40)

Channel	Frequency (MHz)	26dBc Bandwidth (MHz)	
		Chain 0	Chain 1
38	5190	41.09	40.77
46	5230	41.20	40.71

802.11ac (VHT80)

Channel	Frequency (MHz)	26dBc Bandwidth (MHz)	
		Chain 0	Chain 1
42	5210	83.57	84.32

Spectrum Plot of Worst Value

802.11a

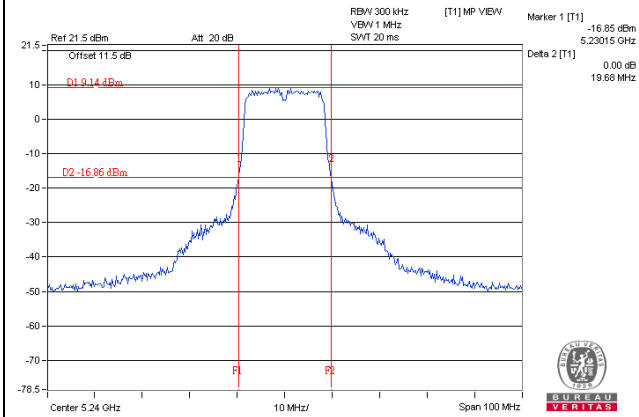

802.11n (HT20)

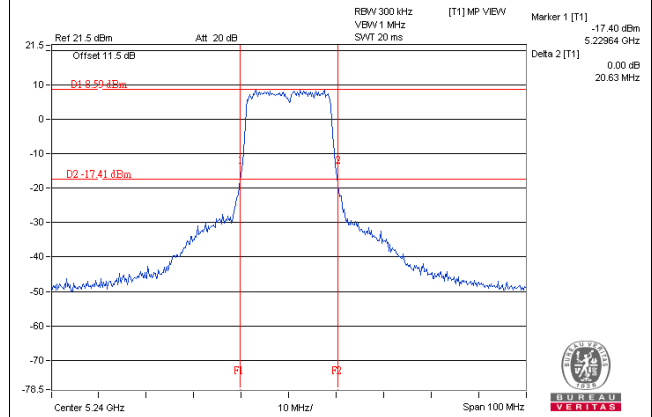

802.11n (HT40)

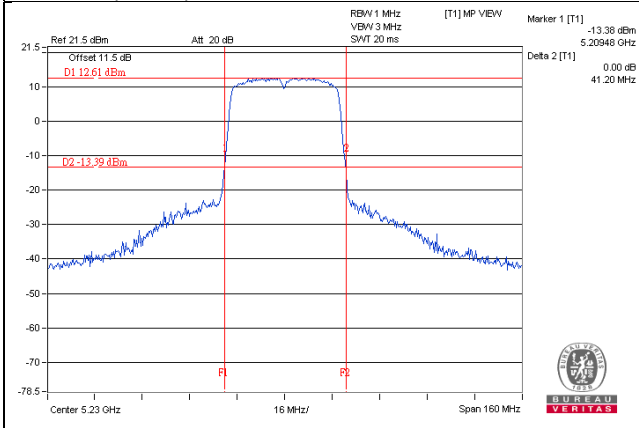

802.11ac (VHT80)

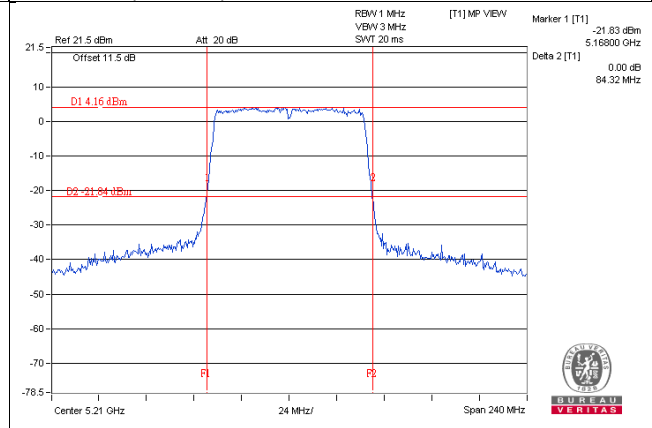

Test Mode F

802.11a

Channel	Frequency (MHz)	26dBc Bandwidth (MHz)
36	5180	36.76
40	5200	36.08
48	5240	34.32

802.11n (HT20)

Channel	Frequency (MHz)	26dBc Bandwidth (MHz)
36	5180	40.42
40	5200	38.18
48	5240	34.71

802.11n (HT40)

Channel	Frequency (MHz)	26dBc Bandwidth (MHz)
38	5190	54.53
46	5230	79.12

802.11ac (VHT80)

Channel	Frequency (MHz)	26dBc Bandwidth (MHz)
42	5210	106.07

Spectrum Plot of Worst Value

802.11a

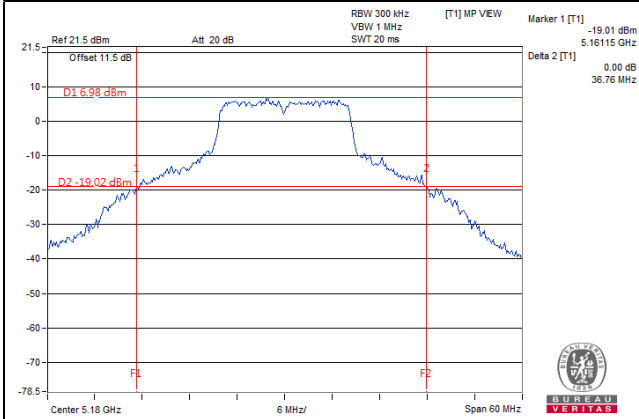

802.11n (HT20)

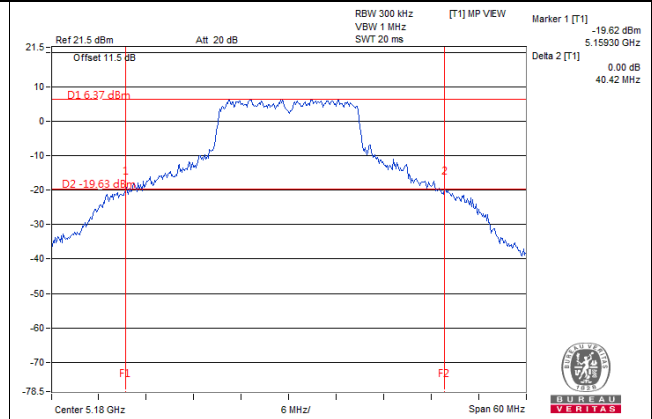

802.11n (HT40)

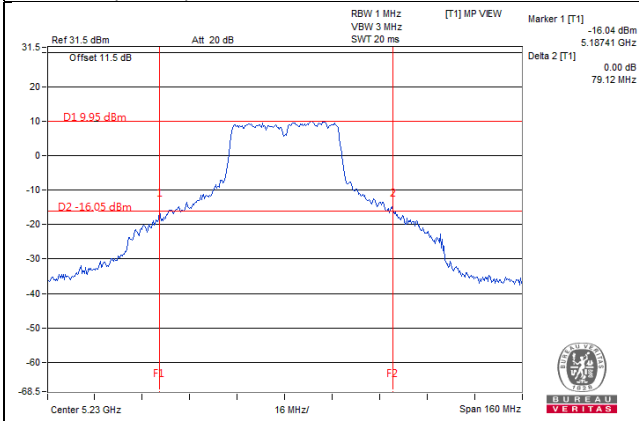

802.11ac (VHT80)

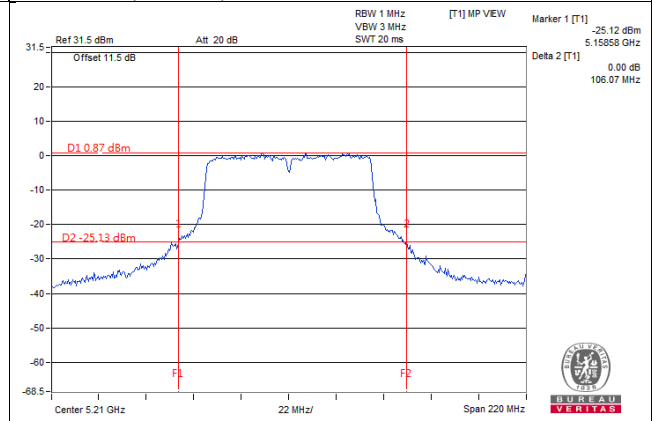

4.4 Occupied Bandwidth Measurement

4.4.1 Test Setup

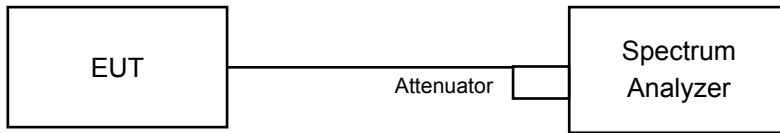

4.4.2 Test Instruments

Refer to section 4.1.2 to get information of above instrument.

4.4.3 Test Procedure

The transmitter output was connected to the spectrum analyzer through an attenuator. The bandwidth of the fundamental frequency was measured by spectrum analyzer with resolution bandwidth in the range of 1% to 5% of the anticipated emission bandwidth, and a video bandwidth at least 3x the resolution bandwidth and set the detector to Sampling. The width of a frequency band such that, below the lower and above the upper frequency limits, the mean powers emitted are each equal to a specified percentage 0.5 %of the total mean power of a given emission.

4.4.4 Test Result

Test Mode A

802.11a

Channel	Frequency (MHz)	Occupied Bandwidth (MHz)	
		Chain 0	Chain 1
36	5180	16.56	16.44
40	5200	16.44	16.44
48	5240	16.56	16.44
149	5745	16.95	16.95
157	5785	17.28	16.92
165	5825	19.68	23.88

802.11n (HT20)

Channel	Frequency (MHz)	Occupied Bandwidth (MHz)	
		Chain 0	Chain 1
36	5180	17.64	17.64
40	5200	17.76	17.64
48	5240	17.64	17.64
149	5745	18.00	18.00
157	5785	18.12	18.00
165	5825	19.80	24.72

802.11n (HT40)

Channel	Frequency (MHz)	Occupied Bandwidth (MHz)	
		Chain 0	Chain 1
38	5190	36.12	36.12
46	5230	36.12	36.12
151	5755	36.60	36.36
159	5795	37.20	36.84

802.11ac (VHT80)

Channel	Frequency (MHz)	Occupied Bandwidth (MHz)	
		Chain 0	Chain 1
42	5210	75.88	75.88
155	5775	76.72	75.88

Spectrum Plot of Worst Value

802.11a

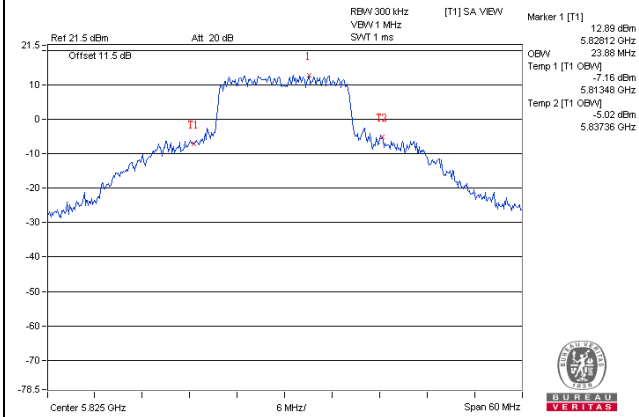

802.11n (HT20)

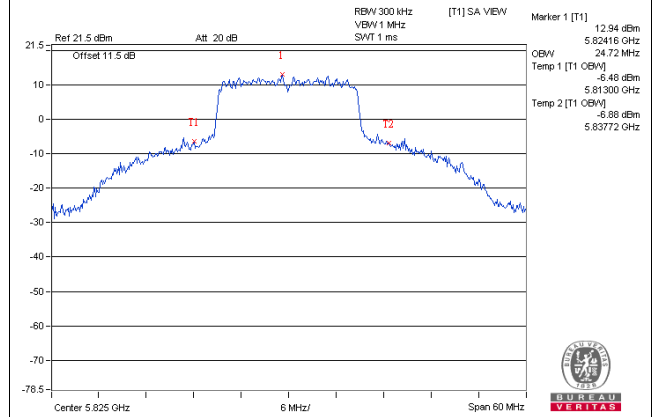

802.11n (HT40)

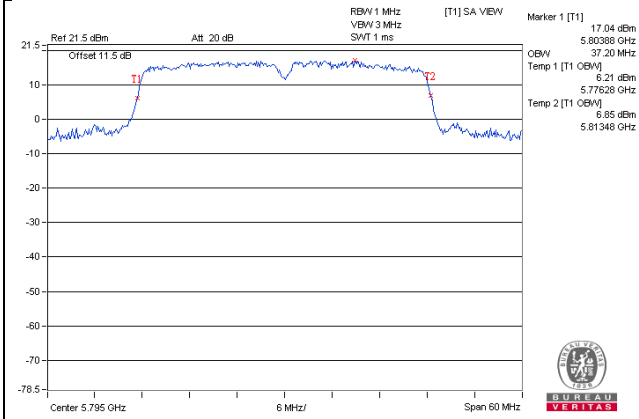

802.11ac (VHT80)

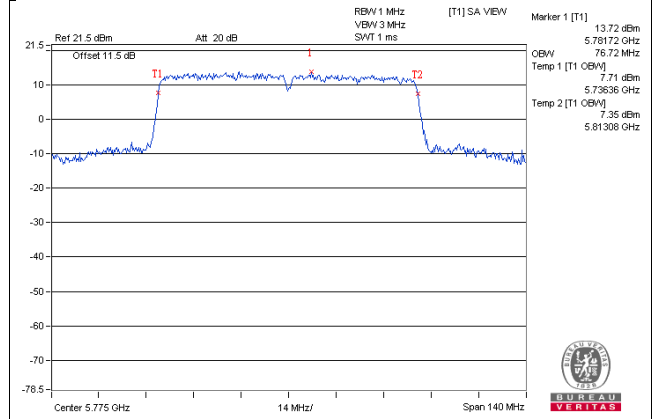

Test Mode B

802.11a

Channel	Frequency (MHz)	Occupied Bandwidth (MHz)	
		Chain 0	Chain 1
36	5180	16.44	16.44
40	5200	16.44	16.44
48	5240	16.44	16.44
149	5745	16.43	16.43
157	5785	16.56	16.56
165	5825	16.56	16.56

802.11n (HT20)

Channel	Frequency (MHz)	Occupied Bandwidth (MHz)	
		Chain 0	Chain 1
36	5180	17.64	17.64
40	5200	17.64	17.64
48	5240	17.64	17.64
149	5745	17.76	17.52
157	5785	17.76	17.64
165	5825	17.76	17.76

802.11n (HT40)

Channel	Frequency (MHz)	Occupied Bandwidth (MHz)	
		Chain 0	Chain 1
38	5190	36.12	36.12
46	5230	36.12	36.12
151	5755	36.24	36.12
159	5795	36.24	36.24

802.11ac (VHT80)

Channel	Frequency (MHz)	Occupied Bandwidth (MHz)	
		Chain 0	Chain 1
42	5210	75.88	75.88
155	5775	75.88	75.88

Spectrum Plot of Worst Value

802.11a

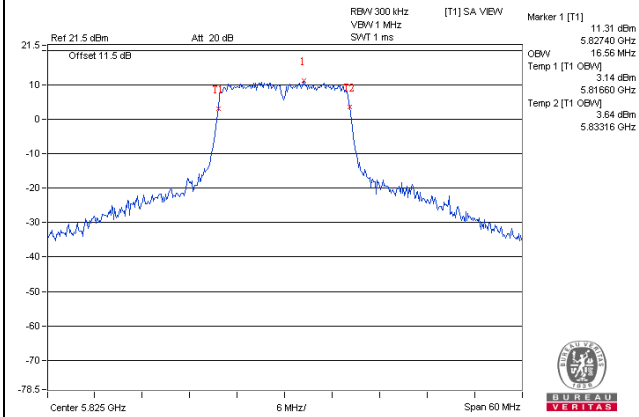

802.11n (HT20)

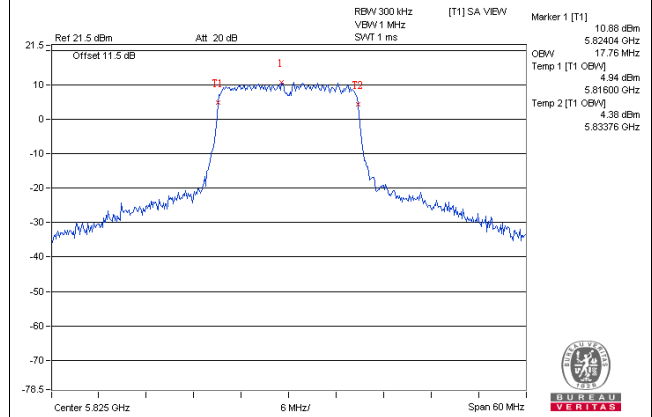

802.11n (HT40)

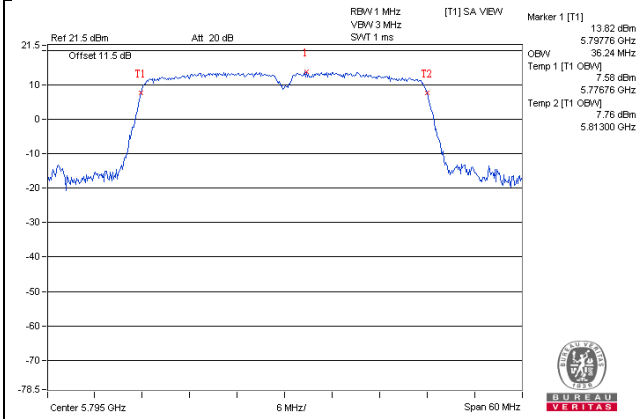

802.11ac (VHT80)

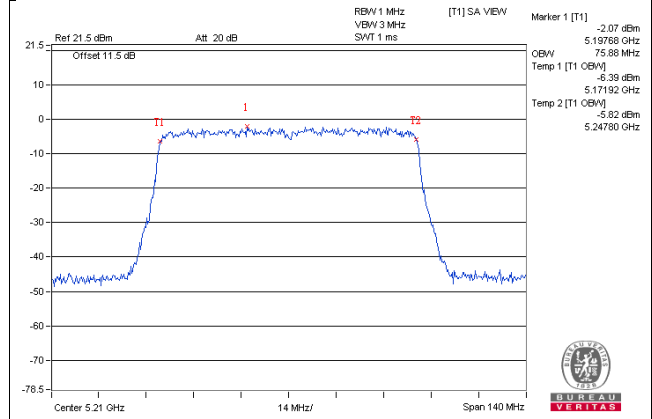

Test Mode C

802.11a

Channel	Frequency (MHz)	Occupied Bandwidth (MHz)	
		Chain 0	Chain 1
36	5180	16.56	16.44
40	5200	16.44	16.44
48	5240	16.44	16.44
149	5745	16.95	16.95
157	5785	17.40	17.40
165	5825	19.08	22.20

802.11n (HT20)

Channel	Frequency (MHz)	Occupied Bandwidth (MHz)	
		Chain 0	Chain 1
36	5180	17.64	17.64
40	5200	17.76	17.76
48	5240	17.64	17.64
149	5745	18.00	18.00
157	5785	18.24	18.24
165	5825	19.32	23.40

802.11n (HT40)

Channel	Frequency (MHz)	Occupied Bandwidth (MHz)	
		Chain 0	Chain 1
38	5190	36.12	36.36
46	5230	36.24	36.24
151	5755	36.72	36.60
159	5795	37.08	36.96

802.11ac (VHT80)

Channel	Frequency (MHz)	Occupied Bandwidth (MHz)	
		Chain 0	Chain 1
42	5210	75.88	75.88
155	5775	77.00	76.16

Spectrum Plot of Worst Value

802.11a

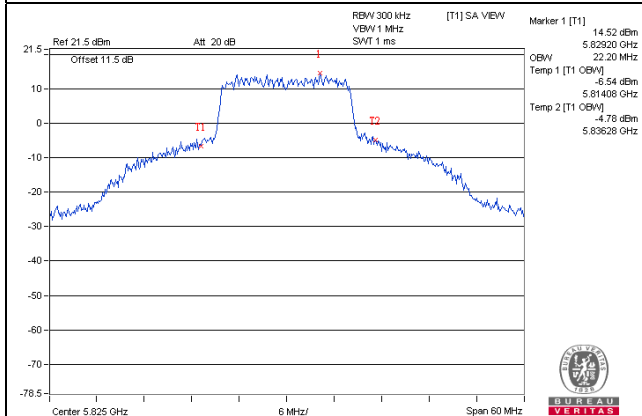

802.11n (HT20)

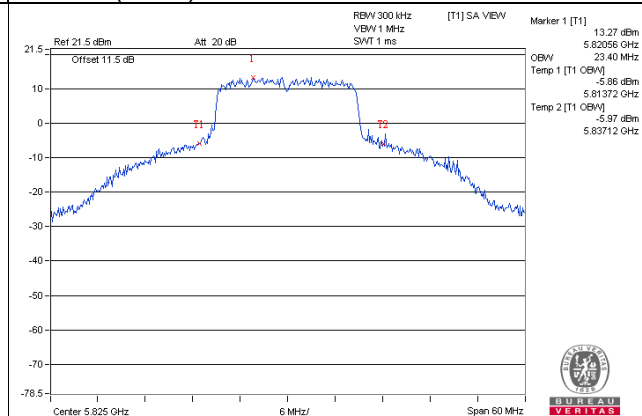

802.11n (HT40)

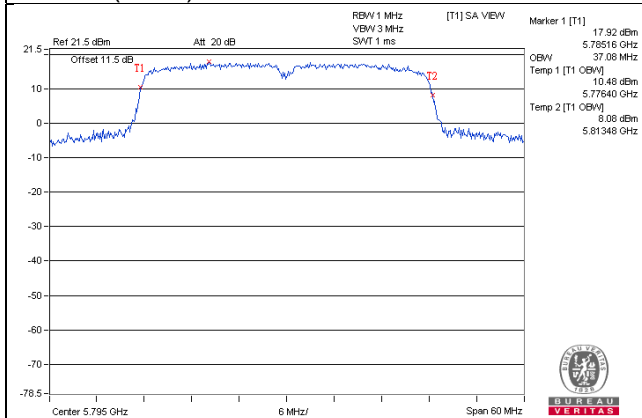

802.11ac (VHT80)

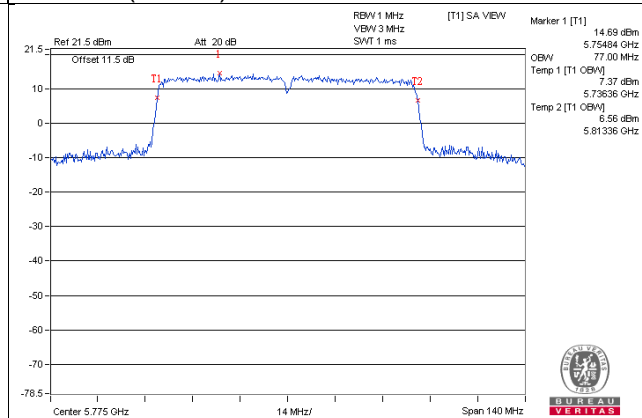

Test Mode D

802.11a

Channel	Frequency (MHz)	Occupied Bandwidth (MHz)	
		Chain 0	Chain 1
36	5180	16.44	16.44
40	5200	16.44	16.44
48	5240	16.44	16.44
149	5745	16.69	16.60
157	5785	16.92	16.92
165	5825	17.16	18.72

802.11n (HT20)

Channel	Frequency (MHz)	Occupied Bandwidth (MHz)	
		Chain 0	Chain 1
36	5180	17.64	17.64
40	5200	17.64	17.64
48	5240	17.64	17.64
149	5745	17.76	17.76
157	5785	17.88	17.88
165	5825	18.12	18.72

802.11n (HT40)

Channel	Frequency (MHz)	Occupied Bandwidth (MHz)	
		Chain 0	Chain 1
38	5190	36.12	36.12
46	5230	36.12	36.12
151	5755	36.48	36.60
159	5795	36.60	36.84

802.11ac (VHT80)

Channel	Frequency (MHz)	Occupied Bandwidth (MHz)	
		Chain 0	Chain 1
42	5210	75.88	75.88
155	5775	76.16	75.88

Spectrum Plot of Worst Value

802.11a

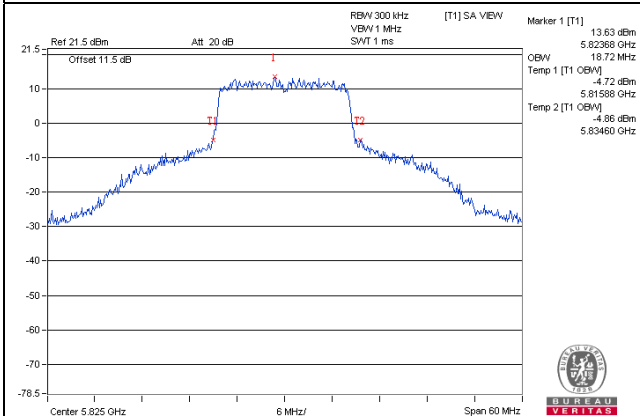

802.11n (HT20)

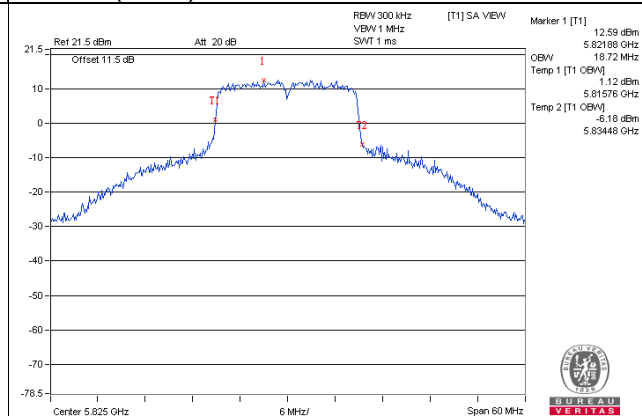

802.11n (HT40)

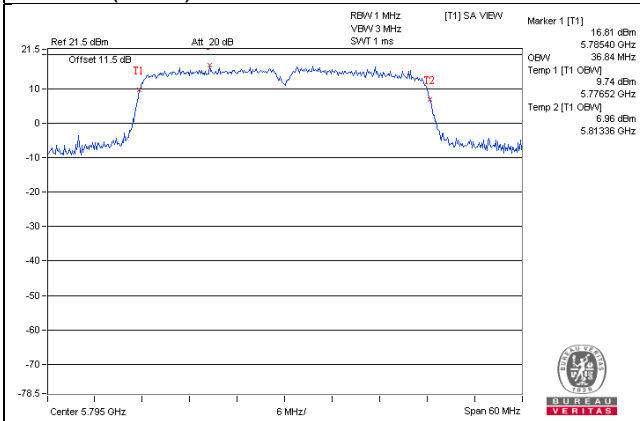

802.11ac (VHT80)

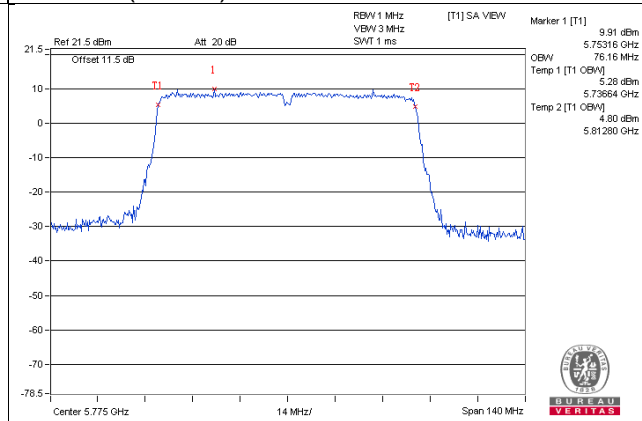

Test Mode E

802.11a

Channel	Frequency (MHz)	Occupied Bandwidth (MHz)	
		Chain 0	Chain 1
36	5180	16.56	16.56
40	5200	16.56	16.56
48	5240	16.56	16.44
149	5745	16.44	16.44
157	5785	16.56	16.56
165	5825	16.56	16.56

802.11n (HT20)

Channel	Frequency (MHz)	Occupied Bandwidth (MHz)	
		Chain 0	Chain 1
36	5180	17.76	17.76
40	5200	17.76	17.52
48	5240	17.76	17.76
149	5745	17.76	17.64
157	5785	17.76	17.76
165	5825	17.76	17.76

802.11n (HT40)

Channel	Frequency (MHz)	Occupied Bandwidth (MHz)	
		Chain 0	Chain 1
38	5190	36.24	36.24
46	5230	36.36	36.48
151	5755	36.24	36.36
159	5795	36.36	36.48

802.11ac (VHT80)

Channel	Frequency (MHz)	Occupied Bandwidth (MHz)	
		Chain 0	Chain 1
42	5210	75.60	75.88
155	5775	75.88	76.16

Spectrum Plot of Worst Value

802.11a

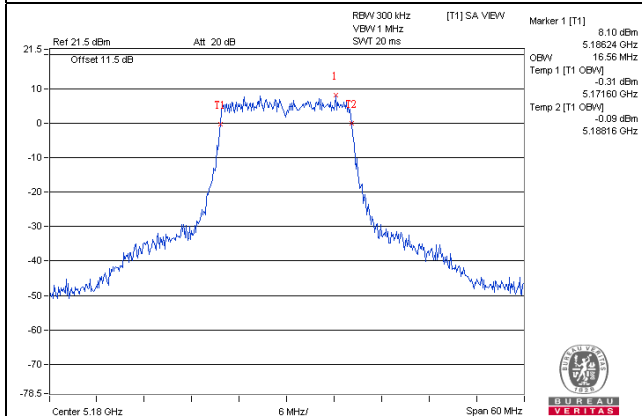

802.11n (HT20)

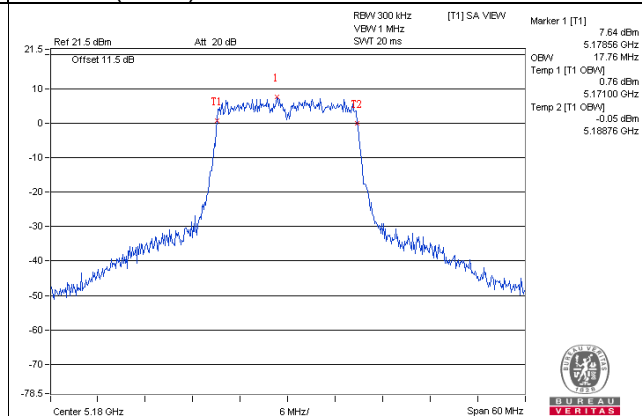

802.11n (HT40)

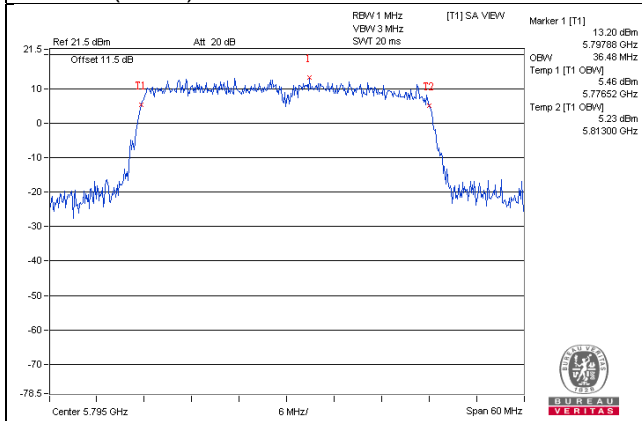

802.11ac (VHT80)

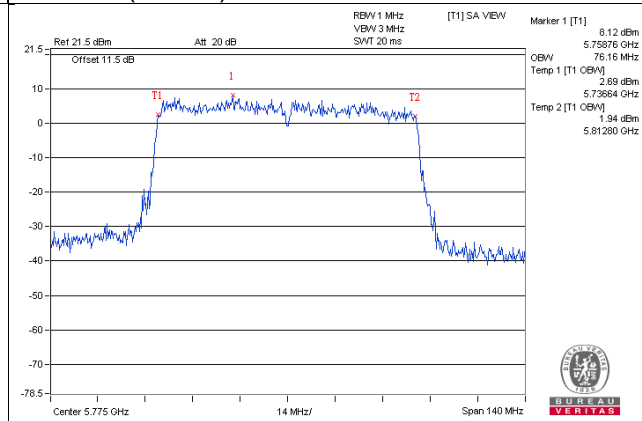

Test Mode F

802.11a

Channel	Frequency (MHz)	Occupied Bandwidth (MHz)
36	5180	21.72
40	5200	21.24
48	5240	19.56
149	5745	28.86
157	5785	29.16
165	5825	29.04

802.11n (HT20)

Channel	Frequency (MHz)	Occupied Bandwidth (MHz)
36	5180	22.08
40	5200	21.36
48	5240	19.80
149	5745	29.64
157	5785	29.88
165	5825	29.28

802.11n (HT40)

Channel	Frequency (MHz)	Occupied Bandwidth (MHz)
38	5190	37.44
46	5230	38.40
151	5755	42.36
159	5795	42.72

802.11ac (VHT80)

Channel	Frequency (MHz)	Occupied Bandwidth (MHz)
42	5210	76.80
155	5775	80.64

Spectrum Plot of Worst Value

802.11a

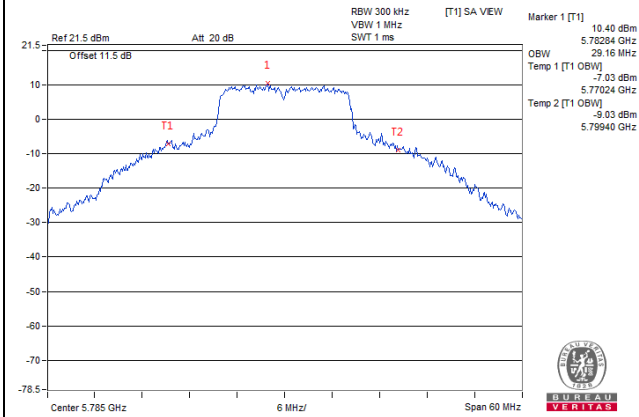

802.11n (HT20)

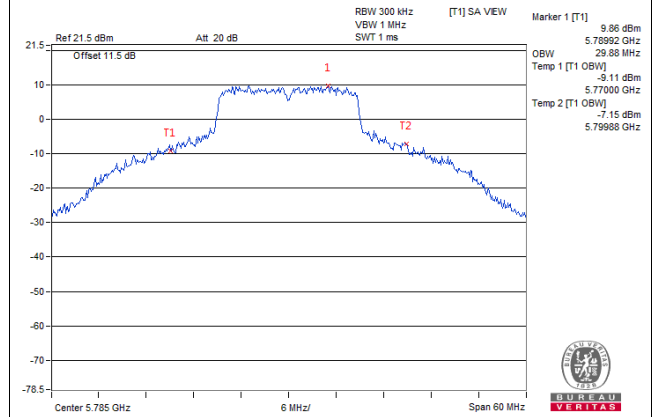

802.11n (HT40)

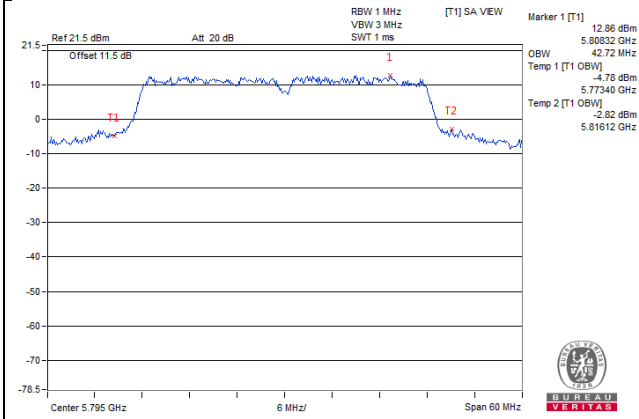

802.11ac (VHT80)

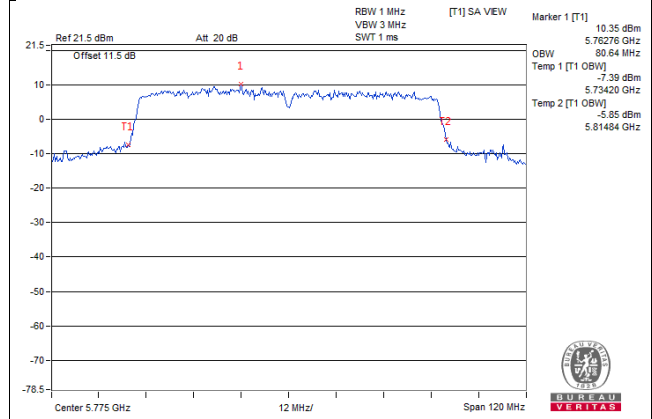

4.5 Peak Power Spectral Density Measurement

4.5.1 Limits of Peak Power Spectral Density Measurement

Operation Band	EUT Category		LIMIT
U-NII-1	√	Outdoor Access Point	17dBm/ MHz
		Fixed point-to-point Access Point	
		Indoor Access Point	11dBm/ MHz
		Mobile and Portable client device	
U-NII-2A	-		11dBm/ MHz
U-NII-2C	-		11dBm/ MHz
U-NII-3	√		30dBm/ 500kHz

4.5.2 Test Setup

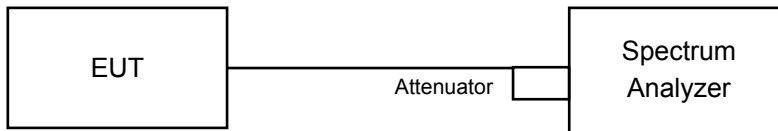

4.5.3 Test Instruments

Refer to section 4.1.2 to get information of above instrument.

4.5.4 Test Procedures

For U-NII-1 band:

Duty cycle of test signal is $\geq 98\%$

Using method SA-1

1. Set span to encompass the entire emission bandwidth (EBW) of the signal.
2. Set RBW = 30 kHz, Set VBW ≥ 1 MHz, Detector = RMS.
3. Set Channel power measure = 1MHz.
4. Sweep time = auto, trigger set to "free run".
5. Trace average at least 100 traces in power averaging mode.
6. Record the max value.

Duty cycle of test signal is $< 98\%$

Using method SA-2

1. Set span to encompass the entire emission bandwidth (EBW) of the signal.
2. Set RBW = 30 kHz, Set VBW ≥ 1 MHz, Detector = RMS.
3. Set Channel power measure = 1MHz.
4. Sweep time = auto, trigger set to "free run".
5. Trace average at least 100 traces in power averaging mode.
6. Record the max value and add $10 \log(1/\text{duty cycle})$.

For U-NII-3 band:

Duty cycle of test signal is $\geq 98\%$

1. Set span to encompass the entire emission bandwidth (EBW) of the signal.
2. Set RBW = 300 kHz, Set VBW ≥ 1 MHz, Detector = RMS.
3. Use the peak marker function to determine the maximum power level in any 300 kHz band segment within the fundamental EBW.
4. Scale the observed power level to an equivalent value in 500 kHz by adjusting (reducing) the measured power by a bandwidth correction factor (BWCF) where $BWCF = 10 \log(500 \text{ kHz}/300 \text{ kHz})$.
5. Sweep time = auto, trigger set to "free run".
6. Trace average at least 100 traces in power averaging mode.
7. Record the max value.

Duty cycle of test signal is $< 98\%$

1. Set span to encompass the entire emission bandwidth (EBW) of the signal.
2. Set RBW = 300 kHz, Set VBW ≥ 1 MHz, Detector = RMS.
3. Use the peak marker function to determine the maximum power level in any 300 kHz band segment within the fundamental EBW.
4. Scale the observed power level to an equivalent value in 500 kHz by adjusting (reducing) the measured power by a bandwidth correction factor (BWCF) where $BWCF = 10 \log(500 \text{ kHz}/300 \text{ kHz})$.
5. Sweep time = auto, trigger set to "free run".
6. Trace average at least 100 traces in power averaging mode.
7. Record the max value and add $10 \log(1/\text{duty cycle})$.

4.5.5 Deviation from Test Standard

No deviation.

4.5.6 EUT Operating Conditions

Same as item 4.3.6.

4.5.7 Test Results

Test Mode A

For U-NII-1 Band

802.11a

Chan.	Freq. (MHz)	PSD W/O Duty Factor (dBm/MHz)		Duty Factor (dB)	Total PSD With Duty Factor (dBm/MHz)	Max. Limit (dBm/MHz)	Pass / Fail
		Chain 0	Chain 1				
36	5180	6.34	5.71	0.21	9.25	12.99	Pass
40	5200	6.32	5.57	0.21	9.18	12.99	Pass
48	5240	6.63	5.48	0.21	9.31	12.99	Pass

Note:

- Method 1 of power density measurement of KDB 662911 is using for calculating total power density. Total power density is summing entire spectra across corresponding frequency bins on the various outputs by computer.
- Directional gain = $7\text{dBi} + 10\log(2) = 10.01\text{dBi} > 6\text{dBi}$, so the limit shall be reduced to $17 - (10.01 - 6) = 12.99\text{dBm}$.
- Refer to section 3.3 for duty cycle spectrum plot.

802.11n (HT20)

Chan.	Freq. (MHz)	PSD (dBm/MHz)		Total PSD (dBm/MHz)	Max. Limit (dBm/MHz)	Pass / Fail
		Chain 0	Chain 1			
36	5180	6.15	5.81	8.99	12.99	Pass
40	5200	6.09	5.63	8.88	12.99	Pass
48	5240	6.27	5.55	8.94	12.99	Pass

Note:

- Method 1 of power density measurement of KDB 662911 is using for calculating total power density. Total power density is summing entire spectra across corresponding frequency bins on the various outputs by computer.
- Directional gain = $7\text{dBi} + 10\log(2) = 10.01\text{dBi} > 6\text{dBi}$, so the limit shall be reduced to $17 - (10.01 - 6) = 12.99\text{dBm}$.

802.11n (HT40)

Chan.	Freq. (MHz)	PSD W/O Duty Factor (dBm/MHz)		Duty Factor (dB)	Total PSD With Duty Factor (dBm/MHz)	Max. Limit (dBm/MHz)	Pass / Fail
		Chain 0	Chain 1				
38	5190	0.05	-0.39	0.19	3.04	12.99	Pass
46	5230	3.67	2.76	0.19	6.44	12.99	Pass

Note:

- Method 1 of power density measurement of KDB 662911 is using for calculating total power density. Total power density is summing entire spectra across corresponding frequency bins on the various outputs by computer.
- Directional gain = $7\text{dBi} + 10\log(2) = 10.01\text{dBi} > 6\text{dBi}$, so the limit shall be reduced to $17 - (10.01 - 6) = 12.99\text{dBm}$.
- Refer to section 3.3 for duty cycle spectrum plot.

802.11ac (VHT80)

Chan.	Freq. (MHz)	PSD W/O Duty Factor (dBm/MHz)		Duty Factor (dB)	Total PSD With Duty Factor (dBm/MHz)	Max. Limit (dBm/MHz)	Pass / Fail
		Chain 0	Chain 1				
42	5210	-5.31	-6.47	0.33	-2.51	12.99	Pass

Note:

- Method 1 of power density measurement of KDB 662911 is using for calculating total power density. Total power density is summing entire spectra across corresponding frequency bins on the various outputs by computer.
- Directional gain = $7\text{dBi} + 10\log(2) = 10.01\text{dBi} > 6\text{dBi}$, so the limit shall be reduced to $17 - (10.01 - 6) = 12.99\text{dBm}$.
- Refer to section 3.3 for duty cycle spectrum plot.

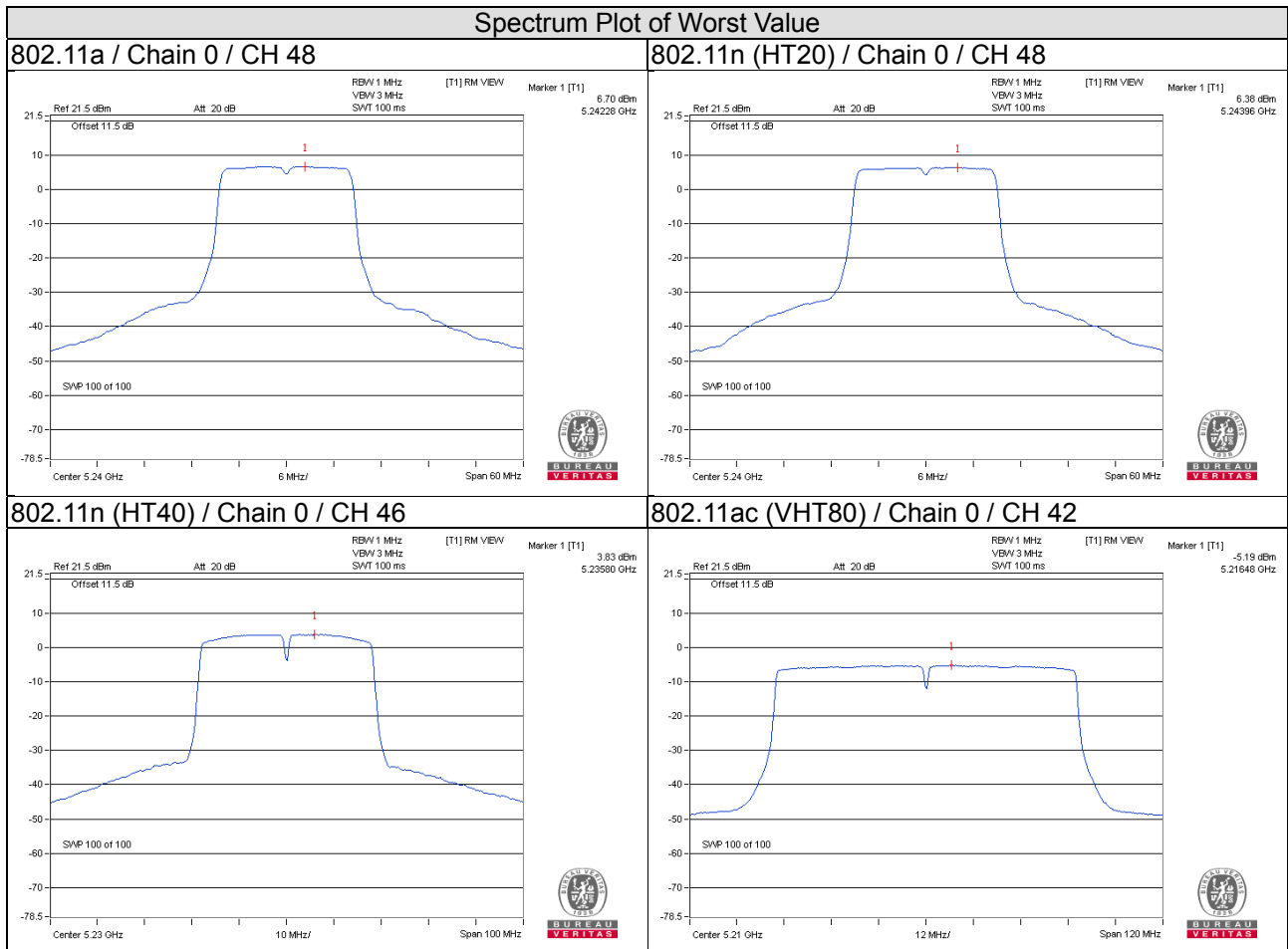

For U-NII-3 Band

802.11a

TX chain	Chan.	Freq. (MHz)	PSD W/O Duty Factor		10 log (N=2) dB	Duty Factor (dB)	Total PSD With Duty Factor (dBm/500kHz)	Limit (dBm/500kHz)	Pass / Fail
			(dBm/300kHz)	(dBm/500kHz)					
0	149	5745	1.46	3.68	3.01	0.21	6.90	25.99	Pass
	157	5785	1.18	3.40	3.01	0.21	6.62	25.99	Pass
	165	5825	1.09	3.31	3.01	0.21	6.53	25.99	Pass
1	149	5745	0.33	2.55	3.01	0.21	5.77	25.99	Pass
	157	5785	-0.37	1.85	3.01	0.21	5.07	25.99	Pass
	165	5825	0.25	2.47	3.01	0.21	5.69	25.99	Pass

Note:

- Method 1 of power density measurement of KDB 662911 is using for calculating total power density. Total power density is summing entire spectra across corresponding frequency bins on the various outputs by computer.
- Directional gain = 7dBi + 10log(2) = 10.01dBi > 6dBi, so the limit shall be reduced to 30-(10.01-6) = 25.99.
- Refer to section 3.3 for duty cycle spectrum plot.

802.11n (HT20)

TX chain	Chan.	Freq. (MHz)	PSD (dBm/300kHz)	PSD (dBm/500kHz)	10 log (N=2) dB	Total PSD (dBm/500kHz)	Limit (dBm/500kHz)	Pass / Fail
0	149	5745	1.13	3.35	3.01	6.36	25.99	Pass
	157	5785	0.82	3.04	3.01	6.05	25.99	Pass
	165	5825	0.87	3.09	3.01	6.10	25.99	Pass
1	149	5745	-0.16	2.06	3.01	5.07	25.99	Pass
	157	5785	-0.56	1.66	3.01	4.67	25.99	Pass
	165	5825	0.00	2.22	3.01	5.23	25.99	Pass

Note:

- Method 1 of power density measurement of KDB 662911 is using for calculating total power density. Total power density is summing entire spectra across corresponding frequency bins on the various outputs by computer.
- Directional gain = 7dBi + 10log(2) = 10.01dBi > 6dBi, so the limit shall be reduced to 30-(10.01-6) = 25.99.

802.11n (HT40)

TX chain	Chan.	Freq. (MHz)	PSD W/O Duty Factor		10 log (N=2) dB	Duty Factor (dB)	Total PSD With Duty Factor (dBm/500kHz)	Limit (dBm/500kHz)	Pass / Fail
			(dBm/300kHz)	(dBm/500kHz)					
0	151	5755	-2.12	0.10	3.01	0.19	3.30	25.99	Pass
	159	5795	-1.69	0.53	3.01	0.19	3.73	25.99	Pass
1	151	5755	-3.79	-1.57	3.01	0.19	1.63	25.99	Pass
	159	5795	-3.60	-1.38	3.01	0.19	1.82	25.99	Pass

Note:

- Method 1 of power density measurement of KDB 662911 is using for calculating total power density. Total power density is summing entire spectra across corresponding frequency bins on the various outputs by computer.
- Directional gain = 7dBi + 10log(2) = 10.01dBi > 6dBi, so the limit shall be reduced to 30-(10.01-6) = 25.99.
- Refer to section 3.3 for duty cycle spectrum plot.

802.11ac (VHT80)

TX chain	Chan.	Freq. (MHz)	PSD W/O Duty Factor		10 log (N=2) dB	Duty Factor (dB)	Total PSD With Duty Factor (dBm/500kHz)	Limit (dBm/500kHz)	Pass / Fail
			(dBm/300kHz)	(dBm/500kHz)					
0	155	5775	-5.84	-3.62	3.01	0.33	-0.28	25.99	Pass
1	155	5775	-11.30	-9.08	3.01	0.33	-5.74	25.99	Pass

Note:

- Method 1 of power density measurement of KDB 662911 is using for calculating total power density. Total power density is summing entire spectra across corresponding frequency bins on the various outputs by computer.
- Directional gain = 7dBi + 10log(2) = 10.01dBi > 6dBi, so the limit shall be reduced to 30-(10.01-6) = 25.99.
- Refer to section 3.3 for duty cycle spectrum plot.

Spectrum Plot of Worst Value

802.11a

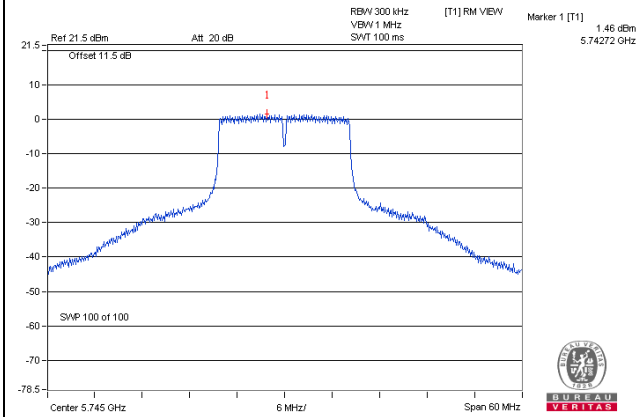

802.11n (HT20)

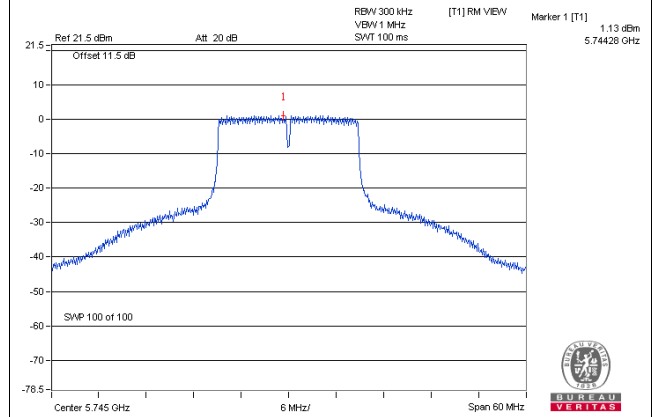

802.11n (HT40)

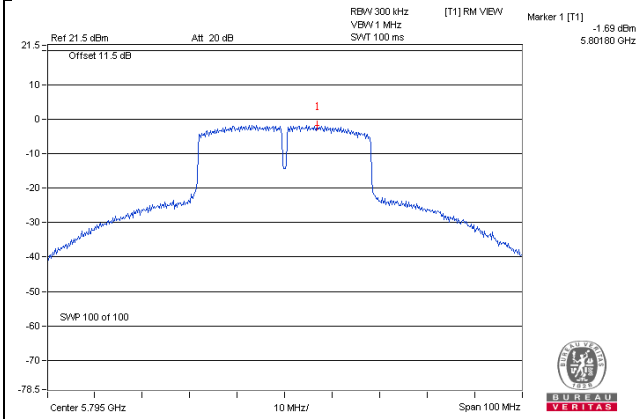

802.11ac (VHT80)

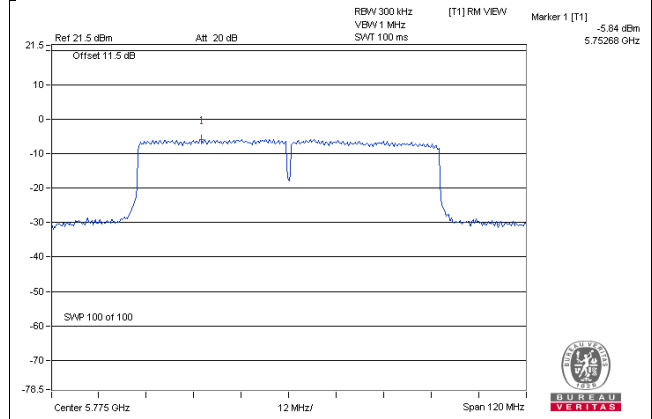

Test Mode B

For U-NII-1 Band

802.11a

Chan.	Freq. (MHz)	PSD W/O Duty Factor (dBm/MHz)		Duty Factor (dB)	Total PSD With Duty Factor (dBm/MHz)	Max. Limit (dBm/MHz)	Pass / Fail
		Chain 0	Chain 1				
36	5180	-6.09	-6.30	0.21	-2.98	6.99	Pass
40	5200	-6.03	-6.49	0.21	-3.04	6.99	Pass
48	5240	-5.78	-6.65	0.21	-2.98	6.99	Pass

Note:

1. Method 1 of power density measurement of KDB 662911 is using for calculating total power density. Total power density is summing entire spectra across corresponding frequency bins on the various outputs by computer.
2. Directional gain = 13dBi + 10log(2) = 16.01dBi > 6dBi, so the limit shall be reduced to 17-(16.01-6) = 6.99dBm.
3. Refer to section 3.3 for duty cycle spectrum plot.

802.11n (HT20)

Chan.	Freq. (MHz)	PSD (dBm/MHz)		Total PSD (dBm/MHz)	Max. Limit (dBm/MHz)	Pass / Fail
		Chain 0	Chain 1			
36	5180	-6.22	-6.29	-3.24	6.99	Pass
40	5200	-6.21	-6.48	-3.33	6.99	Pass
48	5240	-6.02	-6.70	-3.34	6.99	Pass

Note:

1. Method 1 of power density measurement of KDB 662911 is using for calculating total power density. Total power density is summing entire spectra across corresponding frequency bins on the various outputs by computer.
2. Directional gain = 13dBi + 10log(2) = 16.01dBi > 6dBi, so the limit shall be reduced to 17-(16.01-6) = 6.99dBm.

802.11n (HT40)

Chan.	Freq. (MHz)	PSD W/O Duty Factor (dBm/MHz)		Duty Factor (dB)	Total PSD With Duty Factor (dBm/MHz)	Max. Limit (dBm/MHz)	Pass / Fail
		Chain 0	Chain 1				
38	5190	-8.90	-9.17	0.19	-5.83	6.99	Pass
46	5230	-8.69	-9.41	0.19	-5.83	6.99	Pass

Note:

1. Method 1 of power density measurement of KDB 662911 is using for calculating total power density. Total power density is summing entire spectra across corresponding frequency bins on the various outputs by computer.
2. Directional gain = 13dBi + 10log(2) = 16.01dBi > 6dBi, so the limit shall be reduced to 17-(16.01-6) = 6.99dBm.
3. Refer to section 3.3 for duty cycle spectrum plot.

802.11ac (VHT80)

Chan.	Freq. (MHz)	PSD W/O Duty Factor (dBm/MHz)		Duty Factor (dB)	Total PSD With Duty Factor (dBm/MHz)	Max. Limit (dBm/MHz)	Pass / Fail
		Chain 0	Chain 1				
42	5210	-12.27	-12.92	0.33	-9.24	6.99	Pass

Note:

- Method 1 of power density measurement of KDB 662911 is using for calculating total power density. Total power density is summing entire spectra across corresponding frequency bins on the various outputs by computer.
- Directional gain = 13dBi + 10log(2) = 16.01dBi > 6dBi, so the limit shall be reduced to 17-(16.01-6) = 6.99dBm.
- Refer to section 3.3 for duty cycle spectrum plot.

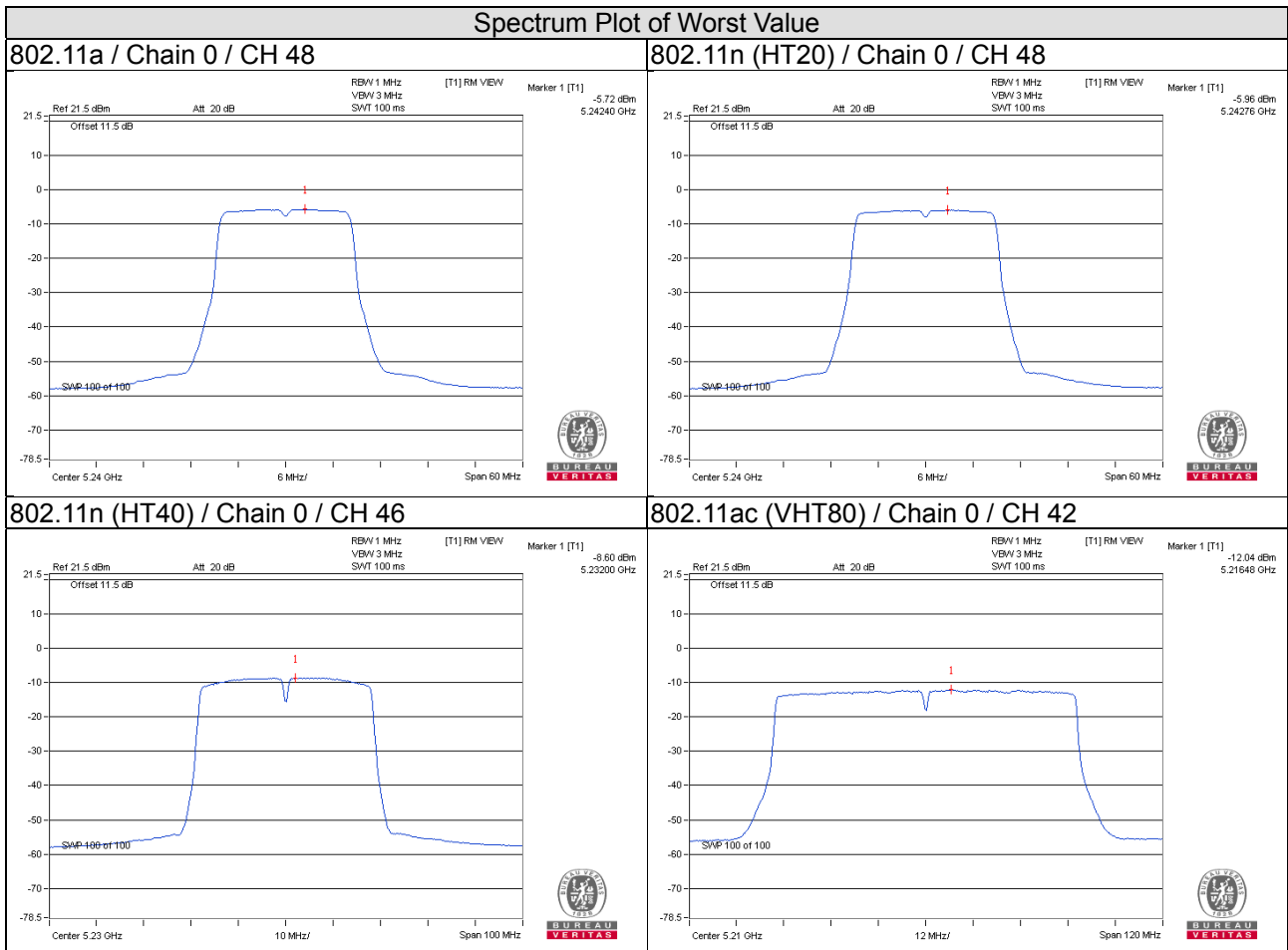

For U-NII-3 Band

802.11a

TX chain	Chan.	Freq. (MHz)	PSD W/O Duty Factor		10 log (N=2) dB	Duty Factor (dB)	Total PSD With Duty Factor (dBm/500kHz)	Limit (dBm/500kHz)	Pass / Fail
			(dBm/300kHz)	(dBm/500kHz)					
0	149	5745	-1.23	0.99	3.01	0.21	4.21	19.99	Pass
	157	5785	-1.40	0.82	3.01	0.21	4.04	19.99	Pass
	165	5825	-1.42	0.80	3.01	0.21	4.02	19.99	Pass
1	149	5745	-2.58	-0.36	3.01	0.21	2.86	19.99	Pass
	157	5785	-2.82	-0.60	3.01	0.21	2.62	19.99	Pass
	165	5825	-2.45	-0.23	3.01	0.21	2.99	19.99	Pass

Note:

- Method 1 of power density measurement of KDB 662911 is using for calculating total power density. Total power density is summing entire spectra across corresponding frequency bins on the various outputs by computer.
- Directional gain = 13dBi + 10log(2) = 16.01dBi > 6dBi, so the limit shall be reduced to 30-(16.01-6) = 19.99.
- Refer to section 3.3 for duty cycle spectrum plot.

802.11n (HT20)

TX chain	Chan.	Freq. (MHz)	PSD (dBm/300kHz)	PSD (dBm/500kHz)	10 log (N=2) dB	Total PSD (dBm/500kHz)	Limit (dBm/500kHz)	Pass / Fail
0	149	5745	-1.45	0.77	3.01	3.78	19.99	Pass
	157	5785	-1.49	0.73	3.01	3.74	19.99	Pass
	165	5825	-1.57	0.65	3.01	3.66	19.99	Pass
1	149	5745	-2.42	-0.20	3.01	2.81	19.99	Pass
	157	5785	-2.61	-0.39	3.01	2.62	19.99	Pass
	165	5825	-2.26	-0.04	3.01	2.97	19.99	Pass

Note:

- Method 1 of power density measurement of KDB 662911 is using for calculating total power density. Total power density is summing entire spectra across corresponding frequency bins on the various outputs by computer.
- Directional gain = 13dBi + 10log(2) = 16.01dBi > 6dBi, so the limit shall be reduced to 30-(16.01-6) = 19.99.

802.11n (HT40)

TX chain	Chan.	Freq. (MHz)	PSD W/O Duty Factor		10 log (N=2) dB	Duty Factor (dB)	Total PSD With Duty Factor (dBm/500kHz)	Limit (dBm/500kHz)	Pass / Fail
			(dBm/300kHz)	(dBm/500kHz)					
0	151	5755	-4.97	-2.75	3.01	0.19	0.45	19.99	Pass
	159	5795	-4.68	-2.46	3.01	0.19	0.74	19.99	Pass
1	151	5755	-5.82	-3.60	3.01	0.19	-0.40	19.99	Pass
	159	5795	-5.86	-3.64	3.01	0.19	-0.44	19.99	Pass

Note:

1. Method 1 of power density measurement of KDB 662911 is using for calculating total power density. Total power density is summing entire spectra across corresponding frequency bins on the various outputs by computer.
2. Directional gain = 13dBi + 10log(2) = 16.01dBi > 6dBi, so the limit shall be reduced to 30-(16.01-6) = 19.99.
3. Refer to section 3.3 for duty cycle spectrum plot.

802.11ac (VHT80)

TX chain	Chan.	Freq. (MHz)	PSD W/O Duty Factor		10 log (N=2) dB	Duty Factor (dB)	Total PSD With Duty Factor (dBm/500kHz)	Limit (dBm/500kHz)	Pass / Fail
			(dBm/300kHz)	(dBm/500kHz)					
0	155	5775	-11.77	-9.55	3.01	0.33	-6.21	19.99	Pass
1	155	5775	-12.72	-10.50	3.01	0.33	-7.16	19.99	Pass

Note:

1. Method 1 of power density measurement of KDB 662911 is using for calculating total power density. Total power density is summing entire spectra across corresponding frequency bins on the various outputs by computer.
2. Directional gain = 13dBi + 10log(2) = 16.01dBi > 6dBi, so the limit shall be reduced to 30-(16.01-6) = 19.99.
3. Refer to section 3.3 for duty cycle spectrum plot.

Spectrum Plot of Worst Value

802.11a

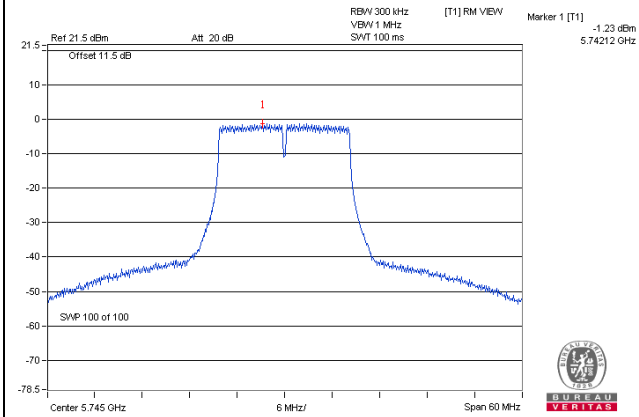

802.11n (HT20)

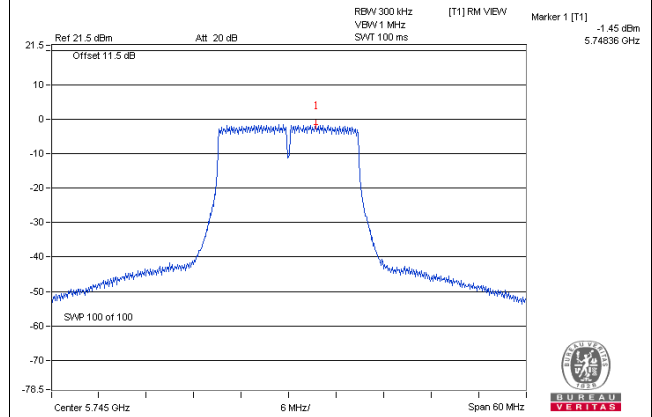

802.11n (HT40)

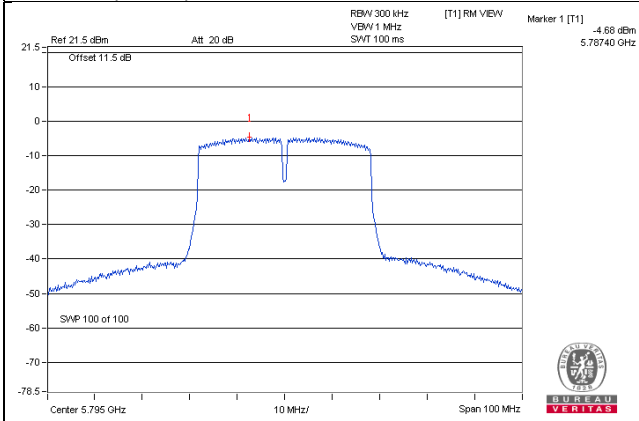

802.11ac (VHT80)

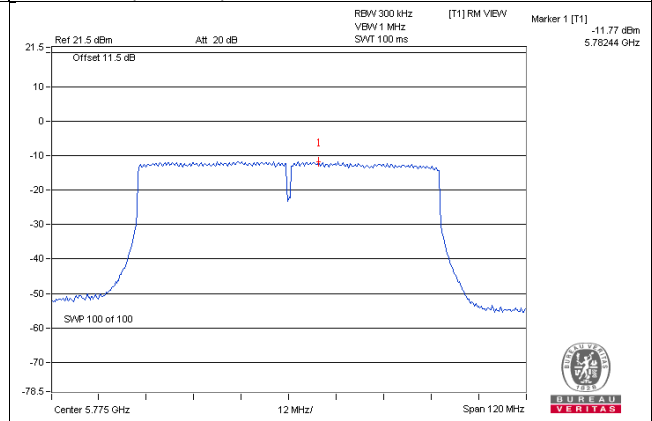

Test Mode C

For U-NII-1 Band

802.11a

Chan.	Freq. (MHz)	PSD W/O Duty Factor (dBm/MHz)		Duty Factor (dB)	Total PSD With Duty Factor (dBm/MHz)	Max. Limit (dBm/MHz)	Pass / Fail
		Chain 0	Chain 1				
36	5180	3.51	2.80	0.21	6.38	12.89	Pass
40	5200	3.44	2.78	0.21	6.34	12.89	Pass
48	5240	3.77	2.81	0.21	6.53	12.89	Pass

Note:

1. Method 1 of power density measurement of KDB 662911 is using for calculating total power density. Total power density is summing entire spectra across corresponding frequency bins on the various outputs by computer.
2. Directional gain = $7.1\text{dBi} + 10\log(2) = 10.11\text{dBi} > 6\text{dBi}$, so the limit shall be reduced to $17 - (10.11 - 6) = 12.89\text{dBm}$.
3. Refer to section 3.3 for duty cycle spectrum plot.

802.11n (HT20)

Chan.	Freq. (MHz)	PSD (dBm/MHz)		Total PSD (dBm/MHz)	Max. Limit (dBm/MHz)	Pass / Fail
		Chain 0	Chain 1			
36	5180	3.26	2.75	6.02	12.89	Pass
40	5200	3.24	2.64	5.96	12.89	Pass
48	5240	3.27	2.66	5.99	12.89	Pass

Note:

1. Method 1 of power density measurement of KDB 662911 is using for calculating total power density. Total power density is summing entire spectra across corresponding frequency bins on the various outputs by computer.
2. Directional gain = $7.1\text{dBi} + 10\log(2) = 10.11\text{dBi} > 6\text{dBi}$, so the limit shall be reduced to $17 - (10.11 - 6) = 12.89\text{dBm}$.

802.11n (HT40)

Chan.	Freq. (MHz)	PSD W/O Duty Factor (dBm/MHz)		Duty Factor (dB)	Total PSD With Duty Factor (dBm/MHz)	Max. Limit (dBm/MHz)	Pass / Fail
		Chain 0	Chain 1				
38	5190	0.20	-0.47	0.19	3.08	12.89	Pass
46	5230	0.31	-0.49	0.19	3.13	12.89	Pass

Note:

1. Method 1 of power density measurement of KDB 662911 is using for calculating total power density. Total power density is summing entire spectra across corresponding frequency bins on the various outputs by computer.
2. Directional gain = $7.1\text{dBi} + 10\log(2) = 10.11\text{dBi} > 6\text{dBi}$, so the limit shall be reduced to $17 - (10.11 - 6) = 12.89\text{dBm}$.
3. Refer to section 3.3 for duty cycle spectrum plot.

802.11ac (VHT80)

Chan.	Freq. (MHz)	PSD W/O Duty Factor (dBm/MHz)		Duty Factor (dB)	Total PSD With Duty Factor (dBm/MHz)	Max. Limit (dBm/MHz)	Pass / Fail
		Chain 0	Chain 1				
42	5210	-4.36	-4.40	0.37	-1.00	12.89	Pass

Note:

- Method 1 of power density measurement of KDB 662911 is using for calculating total power density. Total power density is summing entire spectra across corresponding frequency bins on the various outputs by computer.
- Directional gain = $7.1\text{dBi} + 10\log(2) = 10.11\text{dBi} > 6\text{dBi}$, so the limit shall be reduced to $17-(10.11-6) = 12.89\text{dBm}$.
- Refer to section 3.3 for duty cycle spectrum plot.

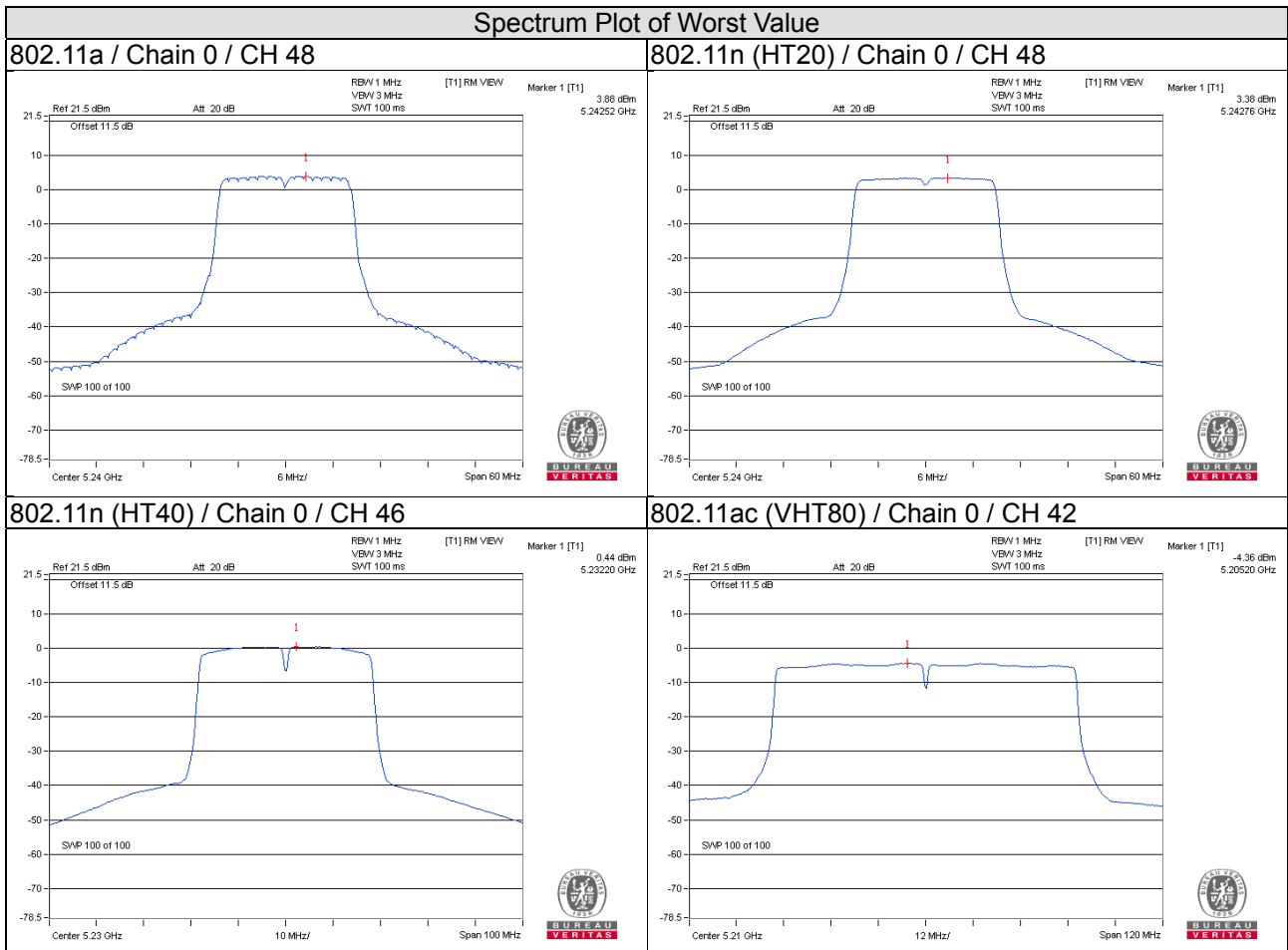

For U-NII-3 Band

802.11a

TX chain	Chan.	Freq. (MHz)	PSD W/O Duty Factor		10 log (N=2) dB	Duty Factor (dB)	Total PSD With Duty Factor (dBm/500kHz)	Limit (dBm/500kHz)	Pass / Fail
			(dBm/300kHz)	(dBm/500kHz)					
0	149	5745	1.85	4.07	3.01	0.21	7.29	25.89	Pass
	157	5785	1.67	3.89	3.01	0.21	7.11	25.89	Pass
	165	5825	1.58	3.80	3.01	0.21	7.02	25.89	Pass
1	149	5745	1.15	3.37	3.01	0.21	6.59	25.89	Pass
	157	5785	0.88	3.10	3.01	0.21	6.32	25.89	Pass
	165	5825	1.00	3.22	3.01	0.21	6.44	25.89	Pass

Note:

1. Method 1 of power density measurement of KDB 662911 is using for calculating total power density. Total power density is summing entire spectra across corresponding frequency bins on the various outputs by computer.
2. Directional gain = 7.1dBi + 10log(2) = 10.11dBi > 6dBi, so the limit shall be reduced to 30-(11.01-6) = 25.89.
3. Refer to section 3.3 for duty cycle spectrum plot.

802.11n (HT20)

TX chain	Chan.	Freq. (MHz)	PSD (dBm/300kHz)	PSD (dBm/500kHz)	10 log (N=2) dB	Total PSD (dBm/500kHz)	Limit (dBm/500kHz)	Pass / Fail
0	149	5745	1.42	3.64	3.01	6.65	25.89	Pass
	157	5785	1.30	3.52	3.01	6.53	25.89	Pass
	165	5825	1.30	3.52	3.01	6.53	25.89	Pass
1	149	5745	0.96	3.18	3.01	6.19	25.89	Pass
	157	5785	0.38	2.60	3.01	5.61	25.89	Pass
	165	5825	0.93	3.15	3.01	6.16	25.89	Pass

Note:

1. Method 1 of power density measurement of KDB 662911 is using for calculating total power density. Total power density is summing entire spectra across corresponding frequency bins on the various outputs by computer.
2. Directional gain = 7.1dBi + 10log(2) = 10.11dBi > 6dBi, so the limit shall be reduced to 30-(11.01-6) = 25.89.

802.11n (HT40)

TX chain	Chan.	Freq. (MHz)	PSD W/O Duty Factor		10 log (N=2) dB	Duty Factor (dB)	Total PSD With Duty Factor (dBm/500kHz)	Limit (dBm/500kHz)	Pass / Fail
			(dBm/300kHz)	(dBm/500kHz)					
0	151	5755	-1.63	0.59	3.01	0.19	3.79	25.89	Pass
	159	5795	-1.25	0.97	3.01	0.19	4.17	25.89	Pass
1	151	5755	-2.53	-0.31	3.01	0.19	2.89	25.89	Pass
	159	5795	-2.64	-0.42	3.01	0.19	2.78	25.89	Pass

Note:

1. Method 1 of power density measurement of KDB 662911 is using for calculating total power density. Total power density is summing entire spectra across corresponding frequency bins on the various outputs by computer.
2. Directional gain = $7.1\text{dBi} + 10\log(2) = 10.11\text{dBi} > 6\text{dBi}$, so the limit shall be reduced to $30 - (11.01 - 6) = 25.89$.
3. Refer to section 3.3 for duty cycle spectrum plot.

802.11ac (VHT80)

TX chain	Chan.	Freq. (MHz)	PSD W/O Duty Factor		10 log (N=2) dB	Duty Factor (dB)	Total PSD With Duty Factor (dBm/500kHz)	Limit (dBm/500kHz)	Pass / Fail
			(dBm/300kHz)	(dBm/500kHz)					
0	155	5775	-5.22	-3.00	3.01	0.37	0.38	25.89	Pass
1	155	5775	-9.48	-7.26	3.01	0.37	-3.88	25.89	Pass

Note:

1. Method 1 of power density measurement of KDB 662911 is using for calculating total power density. Total power density is summing entire spectra across corresponding frequency bins on the various outputs by computer.
2. Directional gain = $7.1\text{dBi} + 10\log(2) = 10.11\text{dBi} > 6\text{dBi}$, so the limit shall be reduced to $30 - (11.01 - 6) = 25.89$.
3. Refer to section 3.3 for duty cycle spectrum plot.

Spectrum Plot of Worst Value

802.11a

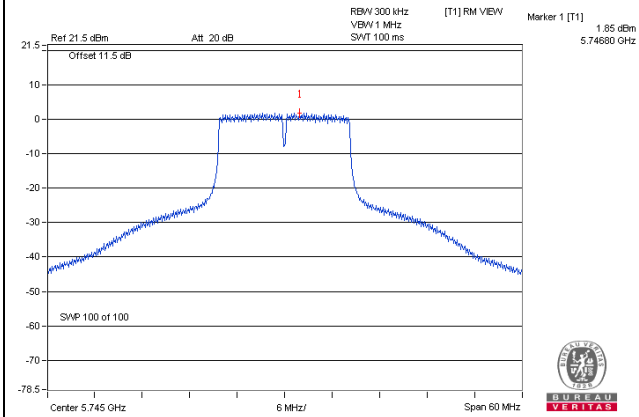

802.11n (HT20)

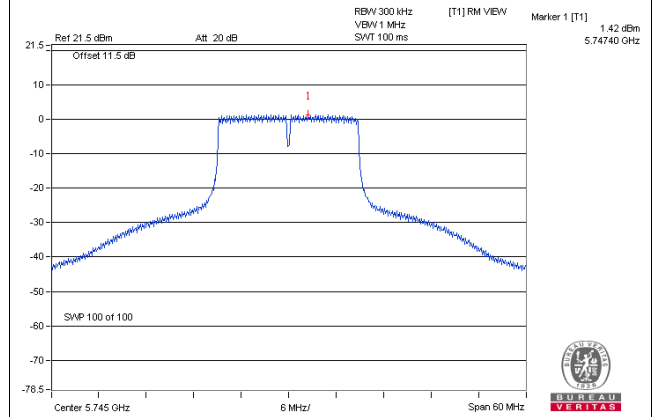

802.11n (HT40)

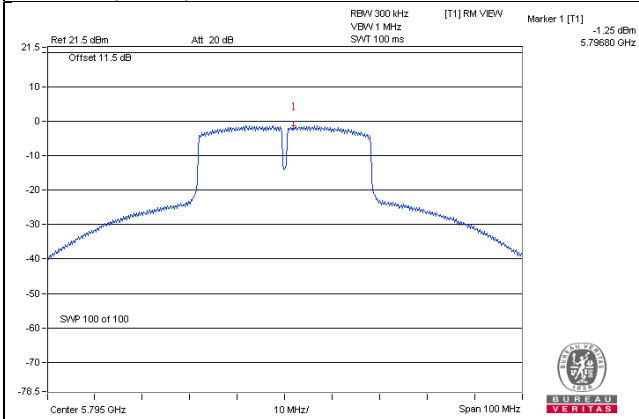

802.11ac (VHT80)

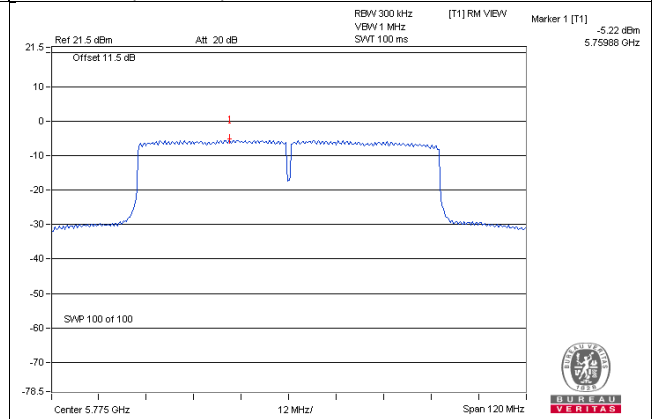

Test Mode D

For U-NII-1 Band

802.11a

Chan.	Freq. (MHz)	PSD W/O Duty Factor (dBm/MHz)		Duty Factor (dB)	Total PSD With Duty Factor (dBm/MHz)	Max. Limit (dBm/MHz)	Pass / Fail
		Chain 0	Chain 1				
36	5180	-3.82	-4.41	0.21	-0.89	8.69	Pass
40	5200	-3.80	-4.50	0.21	-0.92	8.69	Pass
48	5240	-3.63	-4.31	0.21	-0.74	8.69	Pass

Note:

1. Method 1 of power density measurement of KDB 662911 is using for calculating total power density. Total power density is summing entire spectra across corresponding frequency bins on the various outputs by computer.
2. Directional gain = $11.3\text{dBi} + 10\log(2) = 14.31\text{dBi} > 6\text{dBi}$, so the limit shall be reduced to $17-(14.31-6) = 8.69\text{dBm}$.
3. Refer to section 3.3 for duty cycle spectrum plot.

802.11n (HT20)

Chan.	Freq. (MHz)	PSD (dBm/MHz)		Total PSD (dBm/MHz)	Max. Limit (dBm/MHz)	Pass / Fail
		Chain 0	Chain 1			
36	5180	-4.01	-4.52	-1.25	8.69	Pass
40	5200	-4.04	-4.65	-1.32	8.69	Pass
48	5240	-4.16	-4.60	-1.36	8.69	Pass

Note:

1. Method 1 of power density measurement of KDB 662911 is using for calculating total power density. Total power density is summing entire spectra across corresponding frequency bins on the various outputs by computer.
2. Directional gain = $11.3\text{dBi} + 10\log(2) = 14.31\text{dBi} > 6\text{dBi}$, so the limit shall be reduced to $17-(14.31-6) = 8.69\text{dBm}$.

802.11n (HT40)

Chan.	Freq. (MHz)	PSD W/O Duty Factor (dBm/MHz)		Duty Factor (dB)	Total PSD With Duty Factor (dBm/MHz)	Max. Limit (dBm/MHz)	Pass / Fail
		Chain 0	Chain 1				
38	5190	-6.55	-7.27	0.19	-3.69	8.69	Pass
46	5230	-7.03	-7.87	0.19	-4.23	8.69	Pass

Note:

1. Method 1 of power density measurement of KDB 662911 is using for calculating total power density. Total power density is summing entire spectra across corresponding frequency bins on the various outputs by computer.
2. Directional gain = $11.3\text{dBi} + 10\log(2) = 14.31\text{dBi} > 6\text{dBi}$, so the limit shall be reduced to $17-(14.31-6) = 8.69\text{dBm}$.
3. Refer to section 3.3 for duty cycle spectrum plot.

802.11ac (VHT80)

Chan.	Freq. (MHz)	PSD W/O Duty Factor (dBm/MHz)		Duty Factor (dB)	Total PSD With Duty Factor (dBm/MHz)	Max. Limit (dBm/MHz)	Pass / Fail
		Chain 0	Chain 1				
42	5210	-11.12	-11.76	0.33	-8.09	8.69	Pass

Note:

- Method 1 of power density measurement of KDB 662911 is using for calculating total power density. Total power density is summing entire spectra across corresponding frequency bins on the various outputs by computer.
- Directional gain = $11.3\text{dBi} + 10\log(2) = 14.31\text{dBi} > 6\text{dBi}$, so the limit shall be reduced to $17 - (14.31 - 6) = 8.69\text{dBm}$.
- Refer to section 3.3 for duty cycle spectrum plot.

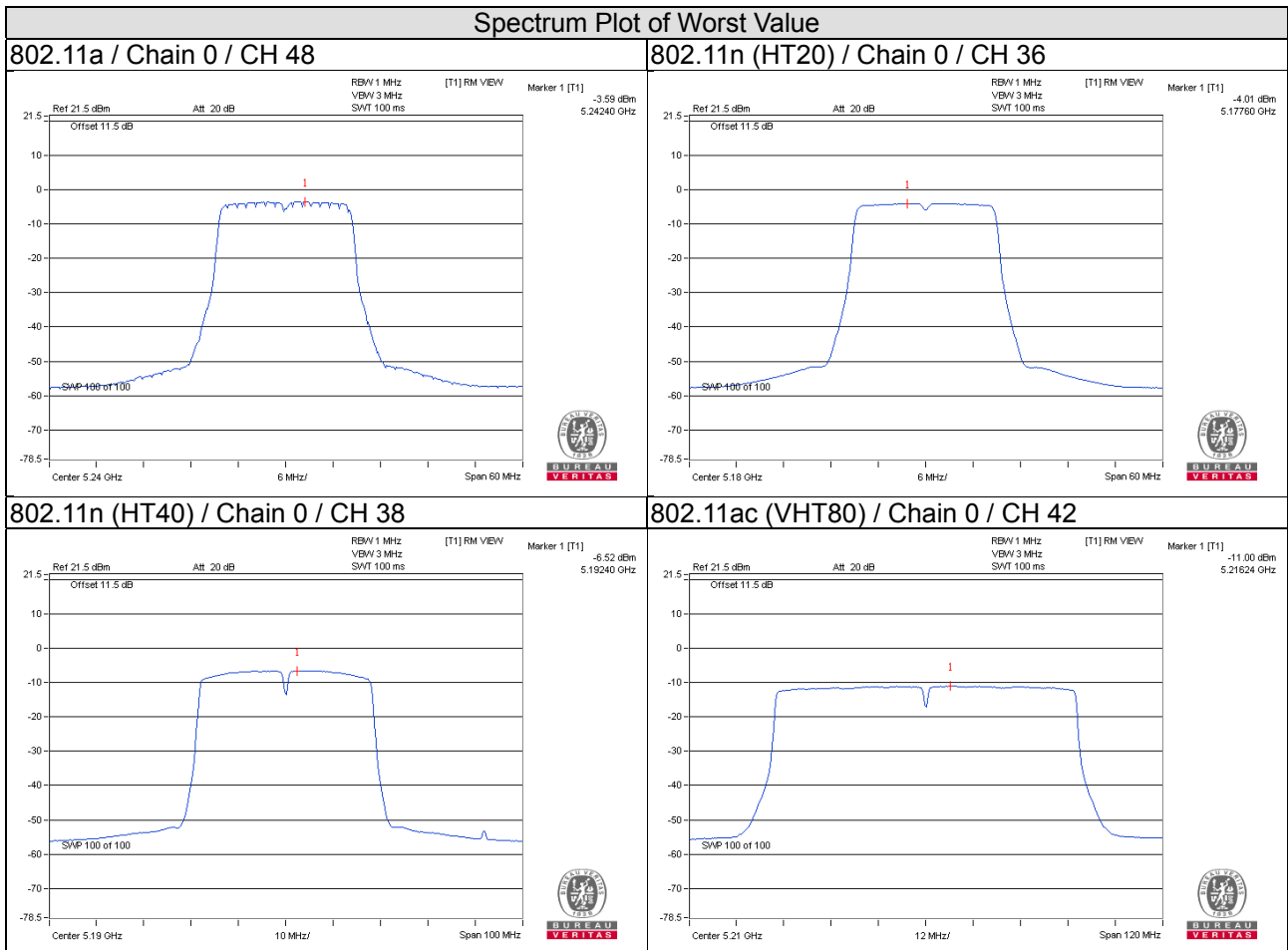

For U-NII-3 Band

802.11a

TX chain	Chan.	Freq. (MHz)	PSD W/O Duty Factor		10 log (N=2) dB	Duty Factor (dB)	Total PSD With Duty Factor (dBm/500kHz)	Limit (dBm/500kHz)	Pass / Fail
			(dBm/300kHz)	(dBm/500kHz)					
0	149	5745	1.04	3.26	3.01	0.21	6.48	21.69	Pass
	157	5785	1.00	3.22	3.01	0.21	6.44	21.69	Pass
	165	5825	0.90	3.12	3.01	0.21	6.34	21.69	Pass
1	149	5745	0.41	2.63	3.01	0.21	5.85	21.69	Pass
	157	5785	0.31	2.53	3.01	0.21	5.75	21.69	Pass
	165	5825	0.21	2.43	3.01	0.21	5.65	21.69	Pass

Note:

- Method 1 of power density measurement of KDB 662911 is using for calculating total power density. Total power density is summing entire spectra across corresponding frequency bins on the various outputs by computer.
- Directional gain = $11.3\text{dBi} + 10\log(2) = 14.31\text{dBi} > 6\text{dBi}$, so the limit shall be reduced to $30 - (14.31 - 6) = 21.69$.
- Refer to section 3.3 for duty cycle spectrum plot.

802.11n (HT20)

TX chain	Chan.	Freq. (MHz)	PSD (dBm/300kHz)	PSD (dBm/500kHz)	10 log (N=2) dB	Total PSD (dBm/500kHz)	Limit (dBm/500kHz)	Pass / Fail
0	149	5745	0.60	2.82	3.01	5.83	21.69	Pass
	157	5785	0.60	2.82	3.01	5.83	21.69	Pass
	165	5825	0.60	2.82	3.01	5.83	21.69	Pass
1	149	5745	0.09	2.31	3.01	5.32	21.69	Pass
	157	5785	-0.07	2.15	3.01	5.16	21.69	Pass
	165	5825	0.11	2.33	3.01	5.34	21.69	Pass

Note:

- Method 1 of power density measurement of KDB 662911 is using for calculating total power density. Total power density is summing entire spectra across corresponding frequency bins on the various outputs by computer.
- Directional gain = $11.3\text{dBi} + 10\log(2) = 14.31\text{dBi} > 6\text{dBi}$, so the limit shall be reduced to $30 - (14.31 - 6) = 21.69$.

802.11n (HT40)

TX chain	Chan.	Freq. (MHz)	PSD W/O Duty Factor		10 log (N=2) dB	Duty Factor (dB)	Total PSD With Duty Factor (dBm/500kHz)	Limit (dBm/500kHz)	Pass / Fail
			(dBm/300kHz)	(dBm/500kHz)					
0	151	5755	-2.20	0.02	3.01	0.19	3.22	21.69	Pass
	159	5795	-2.06	0.16	3.01	0.19	3.36	21.69	Pass
1	151	5755	-2.61	-0.39	3.01	0.19	2.81	21.69	Pass
	159	5795	-2.76	-0.54	3.01	0.19	2.66	21.69	Pass

Note:

1. Method 1 of power density measurement of KDB 662911 is using for calculating total power density. Total power density is summing entire spectra across corresponding frequency bins on the various outputs by computer.
2. Directional gain = $11.3\text{dBi} + 10\log(2) = 14.31\text{dBi} > 6\text{dBi}$, so the limit shall be reduced to $30 - (14.31 - 6) = 21.69$.
3. Refer to section 3.3 for duty cycle spectrum plot.

802.11ac (VHT80)

TX chain	Chan.	Freq. (MHz)	PSD W/O Duty Factor		10 log (N=2) dB	Duty Factor (dB)	Total PSD With Duty Factor (dBm/500kHz)	Limit (dBm/500kHz)	Pass / Fail
			(dBm/300kHz)	(dBm/500kHz)					
0	155	5775	-9.89	-7.67	3.01	0.33	-4.33	21.69	Pass
1	155	5775	-10.16	-7.94	3.01	0.33	-4.60	21.69	Pass

Note:

1. Method 1 of power density measurement of KDB 662911 is using for calculating total power density. Total power density is summing entire spectra across corresponding frequency bins on the various outputs by computer.
2. Directional gain = $11.3\text{dBi} + 10\log(2) = 14.31\text{dBi} > 6\text{dBi}$, so the limit shall be reduced to $30 - (14.31 - 6) = 21.69$.
3. Refer to section 3.3 for duty cycle spectrum plot.

Spectrum Plot of Worst Value

802.11a

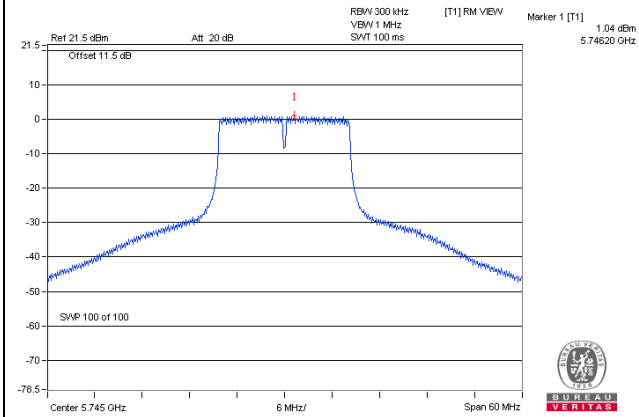

802.11n (HT20)

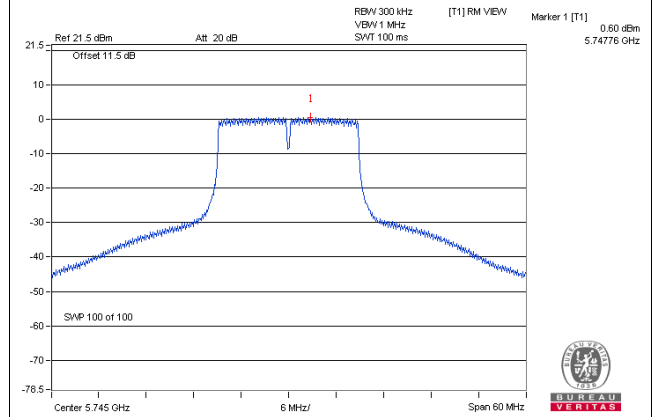

802.11n (HT40)

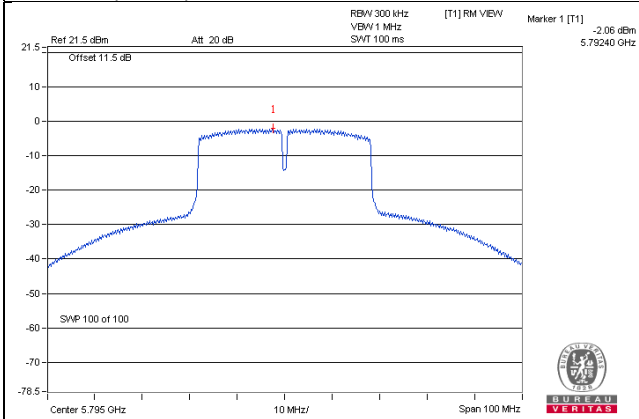

802.11ac (VHT80)

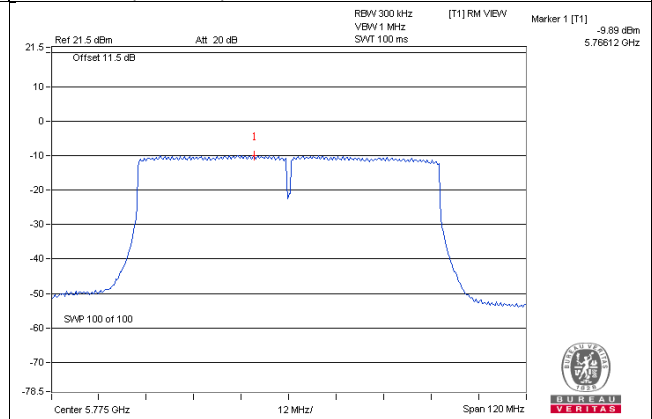

Test Mode E

For U-NII-1 Band

802.11a

Chan.	Freq. (MHz)	PSD W/O Duty Factor (dBm/MHz)		Duty Factor (dB)	Total PSD With Duty Factor (dBm/MHz)	Max. Limit (dBm/MHz)	Pass / Fail
		Chain 0	Chain 1				
36	5180	3.33	2.44	0.21	6.12	6.99	Pass
40	5200	3.44	2.40	0.21	6.17	6.99	Pass
48	5240	3.53	2.62	0.21	6.31	6.99	Pass

Note:

1. Method 1 of power density measurement of KDB 662911 is using for calculating total power density. Total power density is summing entire spectra across corresponding frequency bins on the various outputs by computer.
2. Directional gain = $13\text{dBi} + 10\log(2) = 16.01\text{dBi} > 6\text{dBi}$, so the limit shall be reduced to $17 - (16.01 - 6) = 6.99\text{dBm}$.
3. Refer to section 3.3 for duty cycle spectrum plot.

802.11n (HT20)

Chan.	Freq. (MHz)	PSD (dBm/MHz)		Total PSD (dBm/MHz)	Max. Limit (dBm/MHz)	Pass / Fail
		Chain 0	Chain 1			
36	5180	3.19	2.27	5.76	6.99	Pass
40	5200	3.10	2.51	5.83	6.99	Pass
48	5240	3.18	2.52	5.87	6.99	Pass

Note:

1. Method 1 of power density measurement of KDB 662911 is using for calculating total power density. Total power density is summing entire spectra across corresponding frequency bins on the various outputs by computer.
2. Directional gain = $13\text{dBi} + 10\log(2) = 16.01\text{dBi} > 6\text{dBi}$, so the limit shall be reduced to $17 - (16.01 - 6) = 6.99\text{dBm}$.

802.11n (HT40)

Chan.	Freq. (MHz)	PSD W/O Duty Factor (dBm/MHz)		Duty Factor (dB)	Total PSD With Duty Factor (dBm/MHz)	Max. Limit (dBm/MHz)	Pass / Fail
		Chain 0	Chain 1				
38	5190	-1.27	-2.31	0.19	1.44	6.99	Pass
46	5230	1.58	0.98	0.19	4.49	6.99	Pass

Note:

1. Method 1 of power density measurement of KDB 662911 is using for calculating total power density. Total power density is summing entire spectra across corresponding frequency bins on the various outputs by computer.
2. Directional gain = $13\text{dBi} + 10\log(2) = 16.01\text{dBi} > 6\text{dBi}$, so the limit shall be reduced to $17 - (16.01 - 6) = 6.99\text{dBm}$.
3. Refer to section 3.3 for duty cycle spectrum plot.

802.11ac (VHT80)

Chan.	Freq. (MHz)	PSD W/O Duty Factor (dBm/MHz)		Duty Factor (dB)	Total PSD With Duty Factor (dBm/MHz)	Max. Limit (dBm/MHz)	Pass / Fail
		Chain 0	Chain 1				
42	5210	-6.15	-7.07	0.33	-3.25	6.99	Pass

Note:

- Method 1 of power density measurement of KDB 662911 is using for calculating total power density. Total power density is summing entire spectra across corresponding frequency bins on the various outputs by computer.
- Directional gain = 13dBi + 10log(2) = 16.01dBi > 6dBi, so the limit shall be reduced to 17-(16.01-6) = 6.99dBm.
- Refer to section 3.3 for duty cycle spectrum plot.

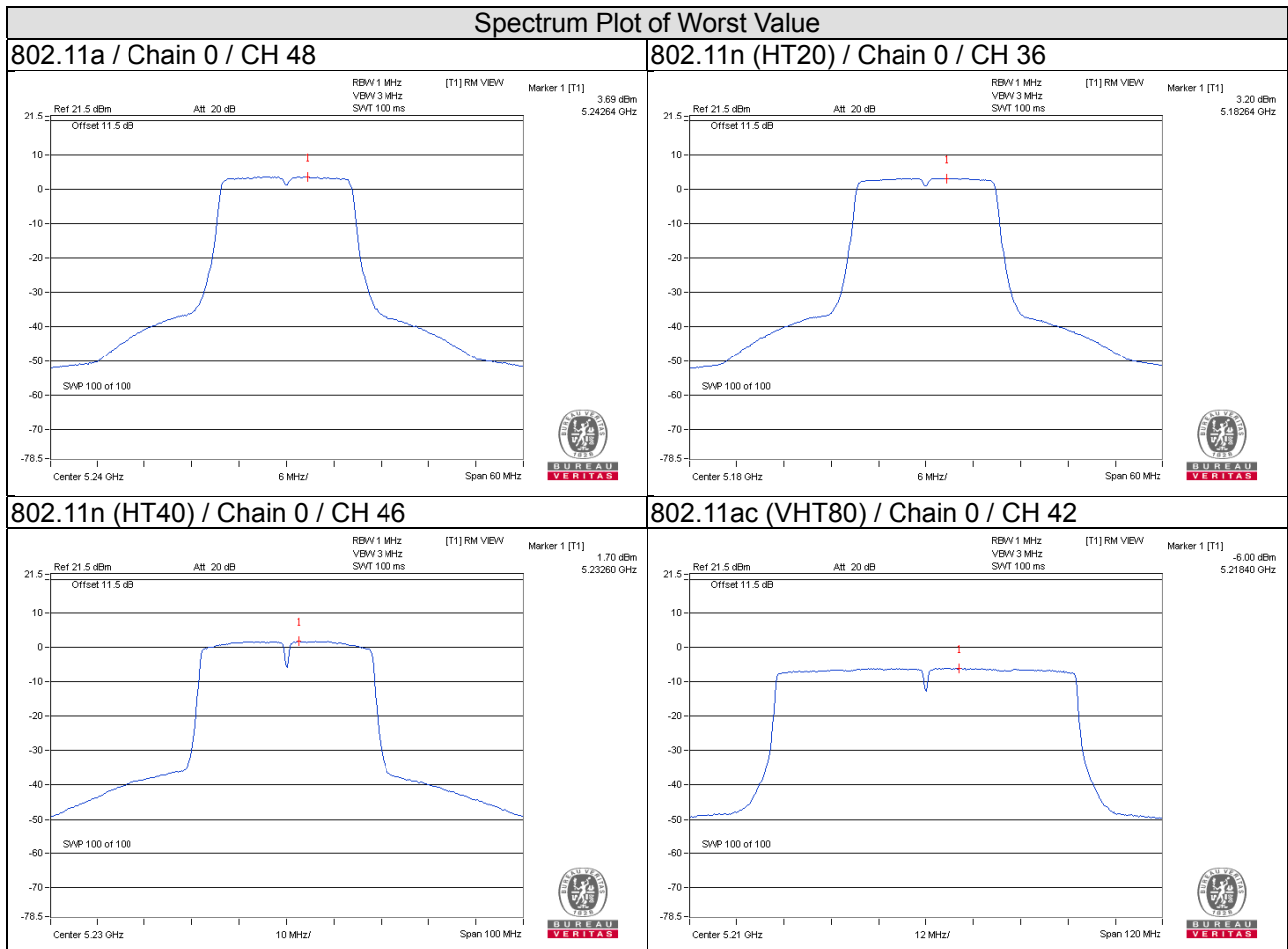

For U-NII-3 Band

802.11a

TX chain	Chan.	Freq. (MHz)	PSD W/O Duty Factor		10 log (N=2) dB	Duty Factor (dB)	Total PSD With Duty Factor (dBm/500kHz)	Limit (dBm/500kHz)	Pass / Fail
			(dBm/300kHz)	(dBm/500kHz)					
0	149	5745	-0.94	1.28	3.01	0.21	4.50	19.99	Pass
	157	5785	-1.43	0.79	3.01	0.21	4.01	19.99	Pass
	165	5825	-2.31	-0.09	3.01	0.21	3.13	19.99	Pass
1	149	5745	-1.44	0.78	3.01	0.21	4.00	19.99	Pass
	157	5785	-1.86	0.36	3.01	0.21	3.58	19.99	Pass
	165	5825	-2.65	-0.43	3.01	0.21	2.79	19.99	Pass

Note:

- Method 1 of power density measurement of KDB 662911 is using for calculating total power density. Total power density is summing entire spectra across corresponding frequency bins on the various outputs by computer.
- Directional gain = 13dBi + 10log(2) = 16.01dBi > 6dBi, so the limit shall be reduced to 30-(16.01-6) = 19.99dBm.
- Refer to section 3.3 for duty cycle spectrum plot.

802.11n (HT20)

TX chain	Chan.	Freq. (MHz)	PSD (dBm/300kHz)	PSD (dBm/500kHz)	10 log (N=2) dB	Total PSD (dBm/500kHz)	Limit (dBm/500kHz)	Pass / Fail
0	149	5745	-1.27	0.95	3.01	3.96	19.99	Pass
	157	5785	-1.84	0.38	3.01	3.39	19.99	Pass
	165	5825	-2.25	-0.03	3.01	2.98	19.99	Pass
1	149	5745	-1.98	0.24	3.01	3.25	19.99	Pass
	157	5785	-2.03	0.19	3.01	3.20	19.99	Pass
	165	5825	-2.28	-0.06	3.01	2.95	19.99	Pass

Note:

- Method 1 of power density measurement of KDB 662911 is using for calculating total power density. Total power density is summing entire spectra across corresponding frequency bins on the various outputs by computer.
- Directional gain = 13dBi + 10log(2) = 16.01dBi > 6dBi, so the limit shall be reduced to 30-(16.01-6) = 19.99dBm.

802.11n (HT40)

TX chain	Chan.	Freq. (MHz)	PSD W/O Duty Factor		10 log (N=2) dB	Duty Factor (dB)	Total PSD With Duty Factor (dBm/500kHz)	Limit (dBm/500kHz)	Pass / Fail
			(dBm/300kHz)	(dBm/500kHz)					
0	151	5755	-4.47	-2.25	3.01	0.19	0.95	19.99	Pass
	159	5795	-4.92	-2.70	3.01	0.19	0.50	19.99	Pass
1	151	5755	-4.94	-2.72	3.01	0.19	0.48	19.99	Pass
	159	5795	-5.22	-3.00	3.01	0.19	0.20	19.99	Pass

Note:

1. Method 1 of power density measurement of KDB 662911 is using for calculating total power density. Total power density is summing entire spectra across corresponding frequency bins on the various outputs by computer.
2. Directional gain = $13\text{dBi} + 10\log(2) = 16.01\text{dBi} > 6\text{dBi}$, so the limit shall be reduced to $30 - (16.01 - 6) = 19.99\text{dBm}$.
3. Refer to section 3.3 for duty cycle spectrum plot.

802.11ac (VHT80)

TX chain	Chan.	Freq. (MHz)	PSD W/O Duty Factor		10 log (N=2) dB	Duty Factor (dB)	Total PSD With Duty Factor (dBm/500kHz)	Limit (dBm/500kHz)	Pass / Fail
			(dBm/300kHz)	(dBm/500kHz)					
0	155	5775	-10.86	-8.64	3.01	0.33	-5.30	19.99	Pass
1	155	5775	-11.07	-8.85	3.01	0.33	-5.51	19.99	Pass

Note:

1. Method 1 of power density measurement of KDB 662911 is using for calculating total power density. Total power density is summing entire spectra across corresponding frequency bins on the various outputs by computer.
2. Directional gain = $13\text{dBi} + 10\log(2) = 16.01\text{dBi} > 6\text{dBi}$, so the limit shall be reduced to $30 - (16.01 - 6) = 19.99\text{dBm}$.
3. Refer to section 3.3 for duty cycle spectrum plot.

Spectrum Plot of Worst Value

802.11a

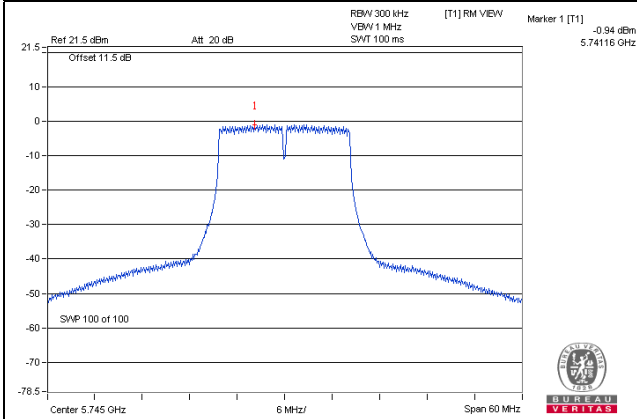

802.11n (HT20)

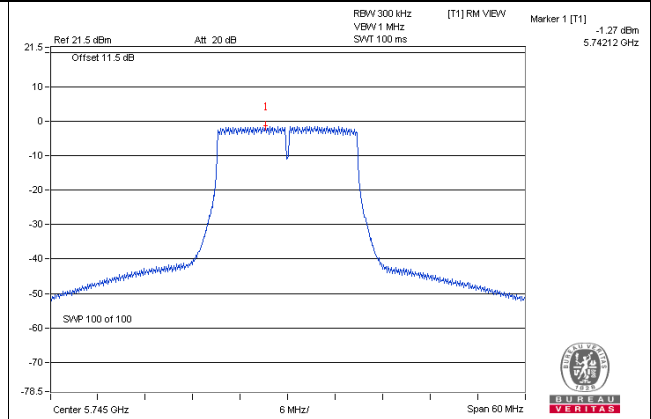

802.11n (HT40)

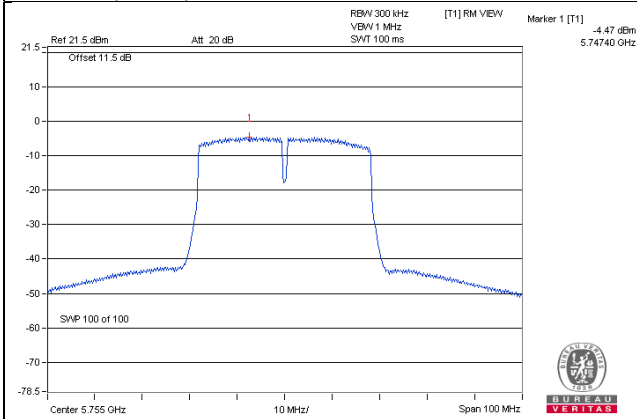

802.11ac (VHT80)

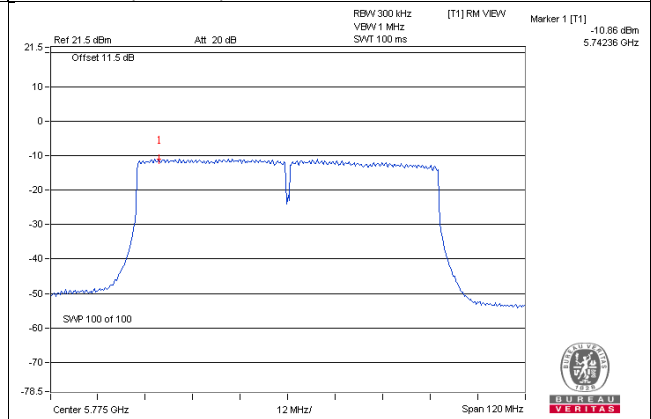

Test Mode F

For U-NII-1 Band

802.11a

Chan.	Freq. (MHz)	PSD W/O Duty Factor (dBm/MHz)	Duty Factor (dB)	PSD With Duty Factor (dBm/MHz)	Max. Limit (dBm/MHz)	Pass / Fail
36	5180	1.77	0.16	1.92	17	Pass
40	5200	1.85	0.16	2.00	17	Pass
48	5240	1.87	0.16	2.02	17	Pass

Note:

1. Refer to section 3.3 for duty cycle spectrum plot.

802.11n (HT20)

Chan.	Freq. (MHz)	PSD W/O Duty Factor (dBm/MHz)	Duty Factor (dB)	PSD With Duty Factor (dBm/MHz)	Max. Limit (dBm/MHz)	Pass / Fail
36	5180	1.59	0.18	1.77	17	Pass
40	5200	1.66	0.18	1.84	17	Pass
48	5240	1.81	0.18	1.99	17	Pass

Note:

1. Refer to section 3.3 for duty cycle spectrum plot.

802.11n (HT40)

Chan.	Freq. (MHz)	PSD W/O Duty Factor (dBm/MHz)	Duty Factor (dB)	PSD With Duty Factor (dBm/MHz)	Max. Limit (dBm/MHz)	Pass / Fail
38	5190	-5.99	0.38	-5.61	17	Pass
46	5230	-0.97	0.38	-0.59	17	Pass

Note:

1. Refer to section 3.3 for duty cycle spectrum plot.

802.11ac (VHT80)

Chan.	Freq. (MHz)	PSD W/O Duty Factor (dBm/MHz)	Duty Factor (dB)	PSD With Duty Factor (dBm/MHz)	Max. Limit (dBm/MHz)	Pass / Fail
42	5210	-10.48	0.60	-9.89	17	Pass

Note:

1. Refer to section 3.3 for duty cycle spectrum plot.

Spectrum Plot of Worst Value

802.11a / CH 48

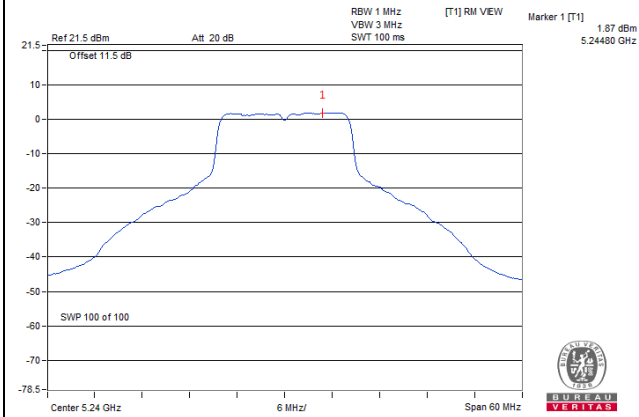

802.11n (HT20) / CH 48

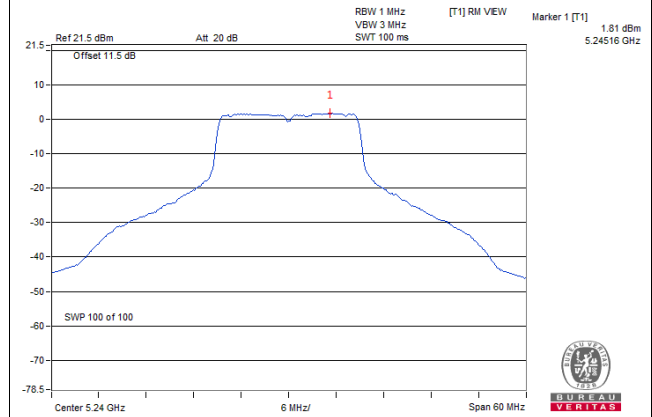

802.11n (HT40) / CH 46

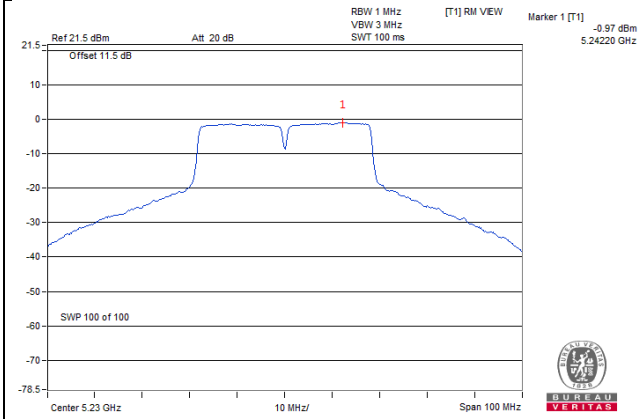

802.11ac (VHT80) / CH 42

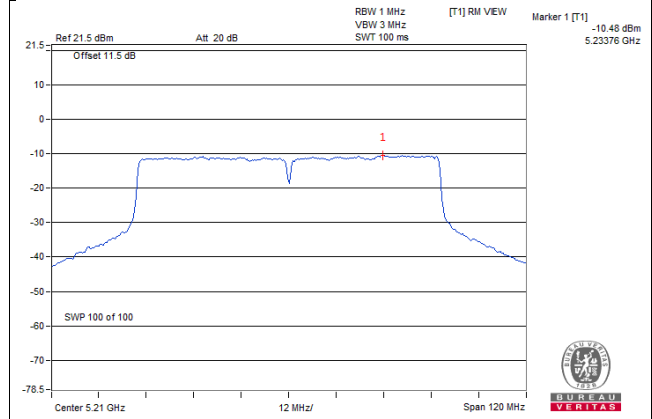

For U-NII-3 Band

802.11a

Chan.	Freq. (MHz)	PSD W/O Duty Factor		Duty Factor (dB)	Total PSD With Duty Factor (dBm/500kHz)	Limit (dBm/500kHz)	Pass / Fail
		(dBm/300kHz)	(dBm/500kHz)				
149	5745	-2.99	-0.77	0.16	-0.61	30	Pass
157	5785	-2.76	-0.54	0.16	-0.38	30	Pass
165	5825	-2.77	-0.55	0.16	-0.39	30	Pass

Note:

1. Refer to section 3.3 for duty cycle spectrum plot.

802.11n (HT20)

Chan.	Freq. (MHz)	PSD W/O Duty Factor		Duty Factor (dB)	Total PSD With Duty Factor (dBm/500kHz)	Limit (dBm/500kHz)	Pass / Fail
		(dBm/300kHz)	(dBm/500kHz)				
149	5745	-3.33	-1.11	0.18	-0.93	30	Pass
157	5785	-3.19	-0.97	0.18	-0.79	30	Pass
165	5825	-3.29	-1.07	0.18	-0.89	30	Pass

Note:

1. Refer to section 3.3 for duty cycle spectrum plot.

802.11n (HT40)

Chan.	Freq. (MHz)	PSD W/O Duty Factor		Duty Factor (dB)	Total PSD With Duty Factor (dBm/500kHz)	Limit (dBm/500kHz)	Pass / Fail
		(dBm/300kHz)	(dBm/500kHz)				
151	5755	-6.82	-4.60	0.38	-4.22	30	Pass
159	5795	-6.78	-4.56	0.38	-4.18	30	Pass

Note:

1. Refer to section 3.3 for duty cycle spectrum plot.

802.11ac (VHT80)

Chan.	Freq. (MHz)	PSD W/O Duty Factor		Duty Factor (dB)	Total PSD With Duty Factor (dBm/500kHz)	Limit (dBm/500kHz)	Pass / Fail
		(dBm/300kHz)	(dBm/500kHz)				
155	5775	-10.12	-7.90	0.60	-7.30	30	Pass

Note:

1. Refer to section 3.3 for duty cycle spectrum plot.

Spectrum Plot of Worst Value

802.11a

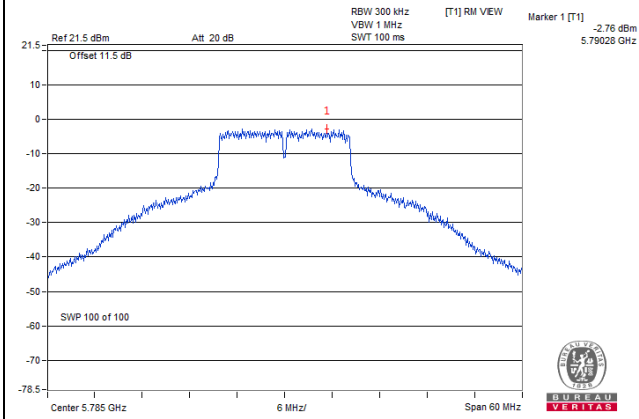

802.11n (HT20)

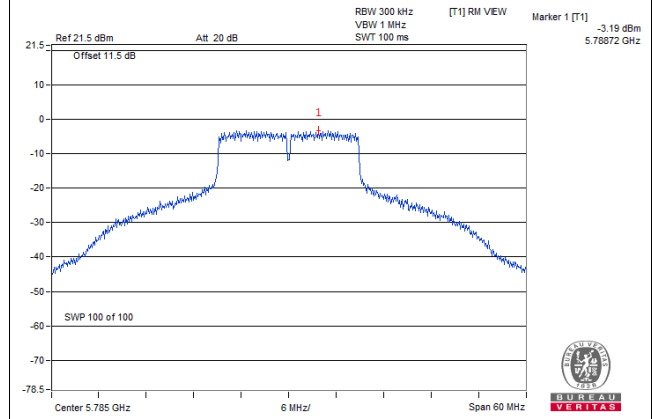

802.11n (HT40)

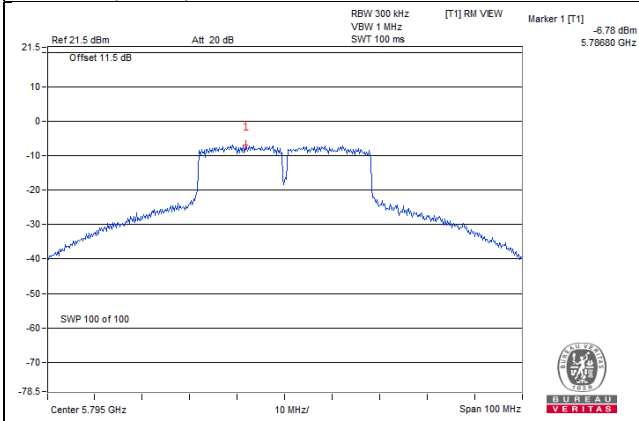

802.11ac (VHT80)

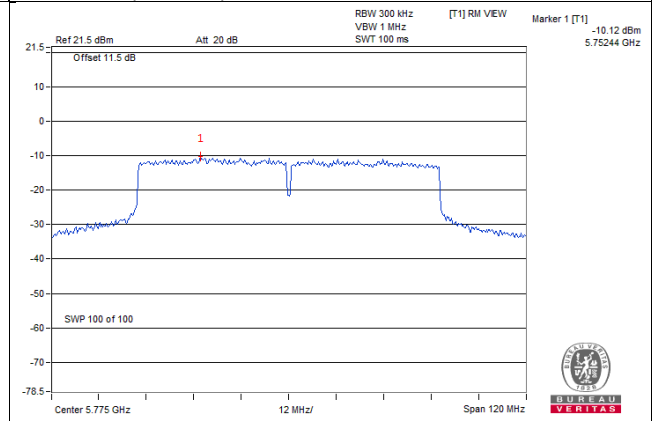

4.6 Frequency Stability

4.6.1 Limits of Frequency Stability Measurement

The frequency of the carrier signal shall be maintained within band of operation

4.6.2 Test Setup

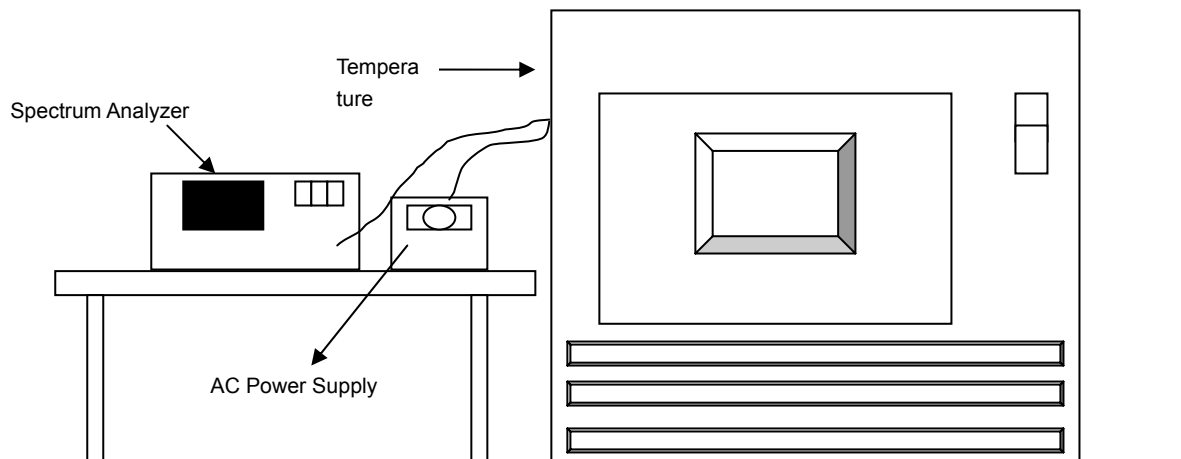

4.6.3 Test Procedure

- The EUT was placed inside the environmental test chamber and powered by nominal AC voltage.
- Turn the EUT on and couple its output to a spectrum analyzer.
- Turn the EUT off and set the chamber to the highest temperature specified.
- Allow sufficient time (approximately 30 min) for the temperature of the chamber to stabilize, turn the EUT on and measure the operating frequency after 2, 5, and 10 minutes.
- Repeat step 2 and 3 with the temperature chamber set to the lowest temperature.
- The test chamber was allowed to stabilize at +20 degree C for a minimum of 30 minutes. The supply voltage was then adjusted on the EUT from 85% to 115% and the frequency record.

4.6.4 Deviation from Test Standard

No deviation.

4.6.5 EUT Operating Condition

Set the EUT transmit at un-modulation mode to test frequency stability.

4.6.6 Test Results

Test Mode A

Frequency Stability Versus Temp.									
Operating Frequency: 5180MHz									
Temp. (°C)	Power Supply (Vac)	0 Minute		2 Minute		5 Minute		10 Minute	
		Measured Frequency (MHz)	Frequency Drift (%)	Measured Frequency (MHz)	Frequency Drift (%)	Measured Frequency (MHz)	Frequency Drift (%)	Measured Frequency (MHz)	Frequency Drift (%)
50	120	5179.9776	-0.00043	5179.9772	-0.00044	5179.9801	-0.00038	5179.9807	-0.00037
40	120	5179.9761	-0.00046	5179.9761	-0.00046	5179.976	-0.00046	5179.9764	-0.00046
30	120	5180.0106	0.00020	5180.0095	0.00018	5180.0087	0.00017	5180.0087	0.00017
20	120	5180.0251	0.00048	5180.0239	0.00046	5180.0203	0.00039	5180.0236	0.00046
10	120	5180.0152	0.00029	5180.0186	0.00036	5180.0179	0.00035	5180.0159	0.00031
0	120	5180.0076	0.00015	5180.0087	0.00017	5180.0073	0.00014	5180.0107	0.00021
-10	120	5179.9984	-0.00003	5180.0014	0.00003	5180.0008	0.00002	5179.9988	-0.00002
-20	120	5180.0224	0.00043	5180.0189	0.00036	5180.0208	0.00040	5180.0177	0.00034
-30	120	5180.0264	0.00051	5180.026	0.00050	5180.0262	0.00051	5180.0271	0.00052

Frequency Stability Versus Voltage									
Operating Frequency: 5180MHz									
Temp. (°C)	Power Supply (Vac)	0 Minute		2 Minute		5 Minute		10 Minute	
		Measured Frequency (MHz)	Frequency Drift (%)	Measured Frequency (MHz)	Frequency Drift (%)	Measured Frequency (MHz)	Frequency Drift (%)	Measured Frequency (MHz)	Frequency Drift (%)
20	138	5180.0253	0.00049	5180.0249	0.00048	5180.0206	0.00040	5180.0245	0.00047
	120	5180.0251	0.00048	5180.0239	0.00046	5180.0203	0.00039	5180.0236	0.00046
	102	5180.0251	0.00048	5180.0244	0.00047	5180.0206	0.00040	5180.0244	0.00047

Test Mode B

Frequency Stability Versus Temp.									
Operating Frequency: 5180MHz									
Temp. (°C)	Power Supply (Vac)	0 Minute		2 Minute		5 Minute		10 Minute	
		Measured Frequency (MHz)	Frequency Drift (%)	Measured Frequency (MHz)	Frequency Drift (%)	Measured Frequency (MHz)	Frequency Drift (%)	Measured Frequency (MHz)	Frequency Drift (%)
50	120	5180.0127	0.00025	5180.0114	0.00022	5180.0125	0.00024	5180.0107	0.00021
40	120	5179.9992	-0.00002	5179.999	-0.00002	5179.9965	-0.00007	5179.9971	-0.00006
30	120	5179.9877	-0.00024	5179.9871	-0.00025	5179.9883	-0.00023	5179.9872	-0.00025
20	120	5179.991	-0.00017	5179.9941	-0.00011	5179.9928	-0.00014	5179.9902	-0.00019
10	120	5179.9837	-0.00031	5179.9847	-0.00030	5179.982	-0.00035	5179.9828	-0.00033
0	120	5180.0198	0.00038	5180.0203	0.00039	5180.0229	0.00044	5180.0229	0.00044
-10	120	5179.997	-0.00006	5179.9965	-0.00007	5179.9996	-0.00001	5179.9965	-0.00007
-20	120	5180.0209	0.00040	5180.0171	0.00033	5180.0193	0.00037	5180.0165	0.00032
-30	120	5179.9872	-0.00025	5179.9841	-0.00031	5179.9829	-0.00033	5179.9849	-0.00029

Frequency Stability Versus Voltage									
Operating Frequency: 5180MHz									
Temp. (°C)	Power Supply (Vac)	0 Minute		2 Minute		5 Minute		10 Minute	
		Measured Frequency (MHz)	Frequency Drift (%)	Measured Frequency (MHz)	Frequency Drift (%)	Measured Frequency (MHz)	Frequency Drift (%)	Measured Frequency (MHz)	Frequency Drift (%)
20	138	5179.9902	-0.00019	5179.9931	-0.00013	5179.9928	-0.00014	5179.9896	-0.00020
	120	5179.991	-0.00017	5179.9941	-0.00011	5179.9928	-0.00014	5179.9902	-0.00019
	102	5179.9917	-0.00016	5179.9935	-0.00013	5179.9925	-0.00014	5179.991	-0.00017

Test Mode C

Frequency Stability Versus Temp.									
Operating Frequency: 5180MHz									
Temp. (°C)	Power Supply (Vac)	0 Minute		2 Minute		5 Minute		10 Minute	
		Measured Frequency (MHz)	Frequency Drift (%)	Measured Frequency (MHz)	Frequency Drift (%)	Measured Frequency (MHz)	Frequency Drift (%)	Measured Frequency (MHz)	Frequency Drift (%)
50	120	5180.0232	0.00045	5180.0231	0.00045	5180.0242	0.00047	5180.0271	0.00052
40	120	5179.9968	-0.00006	5179.995	-0.00010	5179.9969	-0.00006	5179.9956	-0.00008
30	120	5180.022	0.00042	5180.0214	0.00041	5180.0239	0.00046	5180.0211	0.00041
20	120	5180.0043	0.00008	5180.0029	0.00006	5180.002	0.00004	5180.0015	0.00003
10	120	5180.013	0.00025	5180.0168	0.00032	5180.0142	0.00027	5180.0145	0.00028
0	120	5179.9993	-0.00001	5180.0011	0.00002	5179.9995	-0.00001	5179.9974	-0.00005
-10	120	5179.9987	-0.00003	5180.0004	0.00001	5179.9979	-0.00004	5179.9985	-0.00003
-20	120	5179.9922	-0.00015	5179.9895	-0.00020	5179.9909	-0.00018	5179.9938	-0.00012
-30	120	5180.0176	0.00034	5180.0188	0.00036	5180.0189	0.00036	5180.0166	0.00032

Frequency Stability Versus Voltage									
Operating Frequency: 5180MHz									
Temp. (°C)	Power Supply (Vac)	0 Minute		2 Minute		5 Minute		10 Minute	
		Measured Frequency (MHz)	Frequency Drift (%)	Measured Frequency (MHz)	Frequency Drift (%)	Measured Frequency (MHz)	Frequency Drift (%)	Measured Frequency (MHz)	Frequency Drift (%)
20	138	5180.0051	0.00010	5180.0037	0.00007	5180.0017	0.00003	5180.0017	0.00003
	120	5180.0043	0.00008	5180.0029	0.00006	5180.002	0.00004	5180.0015	0.00003
	102	5180.0051	0.00010	5180.0032	0.00006	5180.0016	0.00003	5180.0024	0.00005

Test Mode D

Frequency Stability Versus Temp.									
Operating Frequency: 5180MHz									
Temp. (°C)	Power Supply (Vac)	0 Minute		2 Minute		5 Minute		10 Minute	
		Measured Frequency (MHz)	Frequency Drift (%)	Measured Frequency (MHz)	Frequency Drift (%)	Measured Frequency (MHz)	Frequency Drift (%)	Measured Frequency (MHz)	Frequency Drift (%)
50	120	5180.0174	0.00034	5180.0133	0.00026	5180.0143	0.00028	5180.0182	0.00035
40	120	5180.0093	0.00018	5180.0063	0.00012	5180.0073	0.00014	5180.0069	0.00013
30	120	5179.9998	0.00000	5179.997	-0.00006	5179.9986	-0.00003	5179.9992	-0.00002
20	120	5180.0124	0.00024	5180.0136	0.00026	5180.0107	0.00021	5180.0093	0.00018
10	120	5180.0024	0.00005	5180.0008	0.00002	5180.0021	0.00004	5180.0018	0.00003
0	120	5180.0021	0.00004	5179.9985	-0.00003	5179.9984	-0.00003	5180.0001	0.00000
-10	120	5180.0061	0.00012	5180.0045	0.00009	5180.0048	0.00009	5180.0079	0.00015
-20	120	5180.0258	0.00050	5180.0224	0.00043	5180.0263	0.00051	5180.0252	0.00049
-30	120	5179.9757	-0.00047	5179.9787	-0.00041	5179.9765	-0.00045	5179.9767	-0.00045

Frequency Stability Versus Voltage									
Operating Frequency: 5180MHz									
Temp. (°C)	Power Supply (Vac)	0 Minute		2 Minute		5 Minute		10 Minute	
		Measured Frequency (MHz)	Frequency Drift (%)	Measured Frequency (MHz)	Frequency Drift (%)	Measured Frequency (MHz)	Frequency Drift (%)	Measured Frequency (MHz)	Frequency Drift (%)
20	138	5180.0133	0.00026	5180.013	0.00025	5180.0117	0.00023	5180.0085	0.00016
	120	5180.0124	0.00024	5180.0136	0.00026	5180.0107	0.00021	5180.0093	0.00018
	102	5180.0126	0.00024	5180.0129	0.00025	5180.0113	0.00022	5180.0093	0.00018

Test Mode E

Frequency Stability Versus Temp.									
Operating Frequency: 5180MHz									
Temp. (°C)	Power Supply (Vac)	0 Minute		2 Minute		5 Minute		10 Minute	
		Measured Frequency (MHz)	Frequency Drift (%)	Measured Frequency (MHz)	Frequency Drift (%)	Measured Frequency (MHz)	Frequency Drift (%)	Measured Frequency (MHz)	Frequency Drift (%)
50	120	5179.9944	-0.00011	5179.9968	-0.00006	5179.9931	-0.00013	5179.9922	-0.00015
40	120	5179.9963	-0.00007	5179.9933	-0.00013	5179.9911	-0.00017	5179.9943	-0.00011
30	120	5180.0184	0.00036	5180.0179	0.00035	5180.0171	0.00033	5180.0217	0.00042
20	120	5179.994	-0.00012	5179.9938	-0.00012	5179.9971	-0.00006	5179.9969	-0.00006
10	120	5180.0176	0.00034	5180.0167	0.00032	5180.0153	0.00030	5180.0198	0.00038
0	120	5179.9847	-0.00030	5179.9854	-0.00028	5179.9845	-0.00030	5179.9828	-0.00033
-10	120	5180.0102	0.00020	5180.0137	0.00026	5180.0135	0.00026	5180.0098	0.00019
-20	120	5179.9849	-0.00029	5179.9883	-0.00023	5179.9894	-0.00020	5179.9855	-0.00028
-30	120	5179.9953	-0.00009	5179.9943	-0.00011	5179.9932	-0.00013	5179.9972	-0.00005

Frequency Stability Versus Voltage									
Operating Frequency: 5180MHz									
Temp. (°C)	Power Supply (Vac)	0 Minute		2 Minute		5 Minute		10 Minute	
		Measured Frequency (MHz)	Frequency Drift (%)	Measured Frequency (MHz)	Frequency Drift (%)	Measured Frequency (MHz)	Frequency Drift (%)	Measured Frequency (MHz)	Frequency Drift (%)
20	138	5179.9933	-0.00013	5179.9936	-0.00012	5179.9971	-0.00006	5179.9964	-0.00007
	120	5179.994	-0.00012	5179.9938	-0.00012	5179.9971	-0.00006	5179.9969	-0.00006
	102	5179.9935	-0.00013	5179.993	-0.00014	5179.9981	-0.00004	5179.9961	-0.00008

Test Mode F

Frequency Stability Versus Temp.									
Operating Frequency: 5180MHz									
Temp. (°C)	Power Supply (Vac)	0 Minute		2 Minute		5 Minute		10 Minute	
		Measured Frequency (MHz)	Frequency Drift (%)	Measured Frequency (MHz)	Frequency Drift (%)	Measured Frequency (MHz)	Frequency Drift (%)	Measured Frequency (MHz)	Frequency Drift (%)
50	120	5700.0197	0.00035	5700.0173	0.00030	5700.0195	0.00034	5700.0208	0.00036
40	120	5700.0187	0.00033	5700.0159	0.00028	5700.0161	0.00028	5700.0173	0.00030
30	120	5700.0256	0.00045	5700.0227	0.00040	5700.023	0.00040	5700.0257	0.00045
20	120	5700.0215	0.00038	5700.0225	0.00039	5700.0235	0.00041	5700.0223	0.00039
10	120	5700.0107	0.00019	5700.0095	0.00017	5700.011	0.00019	5700.0109	0.00019
0	120	5700.0044	0.00008	5700.0023	0.00004	5700.0026	0.00005	5700.0024	0.00004
-10	120	5699.9721	-0.00049	5699.9768	-0.00041	5699.9737	-0.00046	5699.9736	-0.00046
-20	120	5700.0141	0.00025	5700.0171	0.00030	5700.016	0.00028	5700.0157	0.00028
-30	120	5699.9924	-0.00013	5699.9895	-0.00018	5699.9904	-0.00017	5699.9926	-0.00013

Frequency Stability Versus Voltage									
Operating Frequency: 5180MHz									
Temp. (°C)	Power Supply (Vac)	0 Minute		2 Minute		5 Minute		10 Minute	
		Measured Frequency (MHz)	Frequency Drift (%)	Measured Frequency (MHz)	Frequency Drift (%)	Measured Frequency (MHz)	Frequency Drift (%)	Measured Frequency (MHz)	Frequency Drift (%)
20	138	5700.0205	0.00036	5700.0217	0.00038	5700.023	0.00040	5700.0216	0.00038
	120	5700.0215	0.00038	5700.0225	0.00039	5700.0235	0.00041	5700.0223	0.00039
	102	5700.0225	0.00039	5700.0222	0.00039	5700.0231	0.00041	5700.0212	0.00037

4.7 6dB Bandwidth Measurement

4.7.1 Limits of 6dB Bandwidth Measurement

The minimum of 6dB Bandwidth Measurement is 0.5MHz.

4.7.2 Test Setup

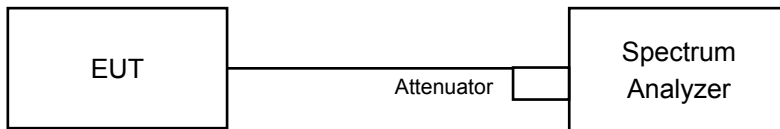

4.7.3 Test Instruments

Refer to section 4.1.2 to get information of above instrument.

4.7.4 Test Procedure

MEASUREMENT PROCEDURE REF

- Set resolution bandwidth (RBW) = 100kHz
- Set the video bandwidth (VBW) $\geq 3 \times$ RBW, Detector = Peak.
- Trace mode = max hold.
- Sweep = auto couple.
- Measure the maximum width of the emission that is constrained by the frequencies associated with the two amplitude points (upper and lower) that are attenuated by 6 dB relative to the maximum level measured in the fundamental emission

4.7.5 Deviation from Test Standard

No deviation.

4.7.6 EUT Operating Condition

The software provided by client to enable the EUT under transmission condition continuously at lowest, middle and highest channel frequencies individually.

4.7.7 Test Results

Test Mode A

802.11a

Channel	Frequency (MHz)	6dB Bandwidth (MHz)		Minimum Limit (MHz)	Pass / Fail
		Chain 0	Chain 1		
149	5745	16.38	16.36	0.5	Pass
157	5785	16.39	16.38	0.5	Pass
165	5825	16.37	16.34	0.5	Pass

802.11n (HT20)

Channel	Frequency (MHz)	6dB Bandwidth (MHz)		Minimum Limit (MHz)	Pass / Fail
		Chain 0	Chain 1		
149	5745	17.63	17.59	0.5	Pass
157	5785	17.63	17.59	0.5	Pass
165	5825	17.62	17.60	0.5	Pass

802.11n (HT40)

Channel	Frequency (MHz)	6dB Bandwidth (MHz)		Minimum Limit (MHz)	Pass / Fail
		Chain 0	Chain 1		
151	5755	35.52	35.46	0.5	Pass
159	5795	35.44	35.46	0.5	Pass

802.11ac (VHT80)

Channel	Frequency (MHz)	6dB Bandwidth (MHz)		Minimum Limit (MHz)	Pass / Fail
		Chain 0	Chain 1		
155	5775	75.94	76.07	0.5	Pass

Spectrum Plot of Worst Value

802.11a

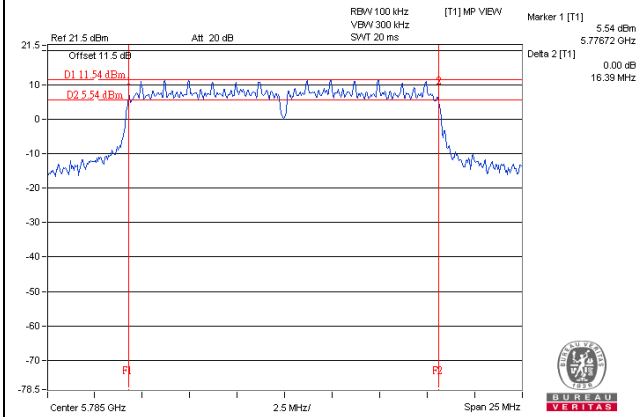

802.11n (HT20)

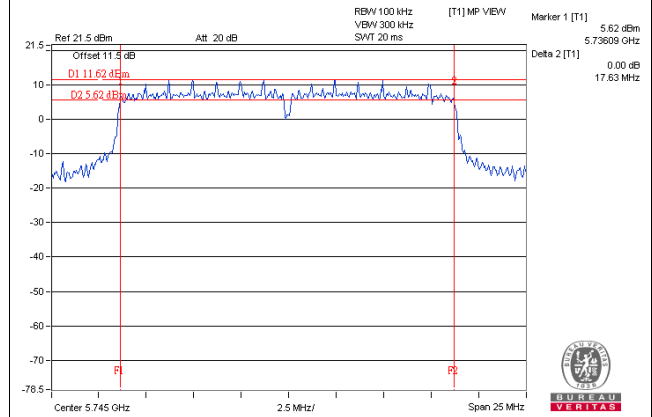

802.11n (HT40)

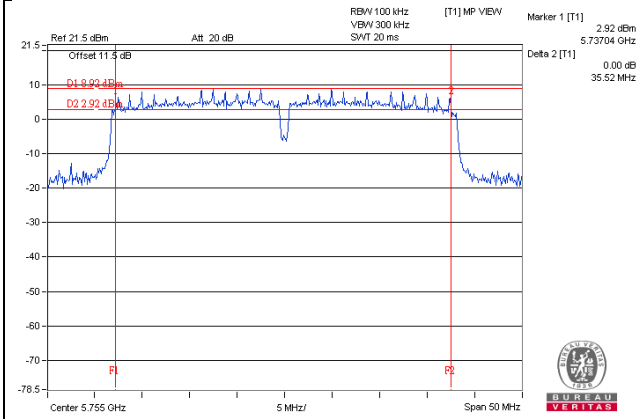

802.11ac (VHT80)

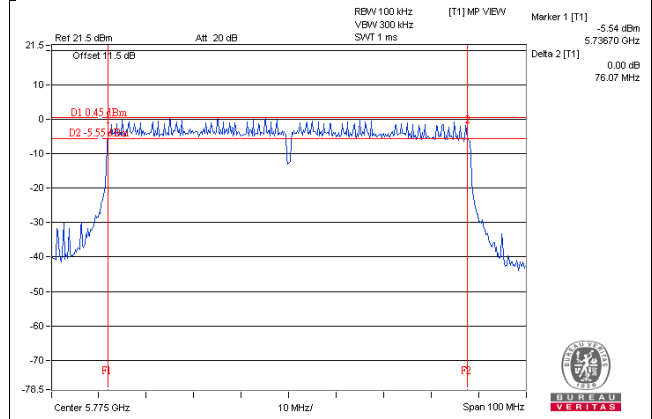

Test Mode B

802.11a

Channel	Frequency (MHz)	6dB Bandwidth (MHz)		Minimum Limit (MHz)	Pass / Fail
		Chain 0	Chain 1		
149	5745	16.40	16.39	0.5	Pass
157	5785	16.41	16.42	0.5	Pass
165	5825	16.41	16.39	0.5	Pass

802.11n (HT20)

Channel	Frequency (MHz)	6dB Bandwidth (MHz)		Minimum Limit (MHz)	Pass / Fail
		Chain 0	Chain 1		
149	5745	17.65	17.63	0.5	Pass
157	5785	17.66	17.62	0.5	Pass
165	5825	17.64	17.61	0.5	Pass

802.11n (HT40)

Channel	Frequency (MHz)	6dB Bandwidth (MHz)		Minimum Limit (MHz)	Pass / Fail
		Chain 0	Chain 1		
151	5755	35.66	35.46	0.5	Pass
159	5795	35.48	35.56	0.5	Pass

802.11ac (VHT80)

Channel	Frequency (MHz)	6dB Bandwidth (MHz)		Minimum Limit (MHz)	Pass / Fail
		Chain 0	Chain 1		
155	5775	76.24	76.10	0.5	Pass

Spectrum Plot of Worst Value

802.11a

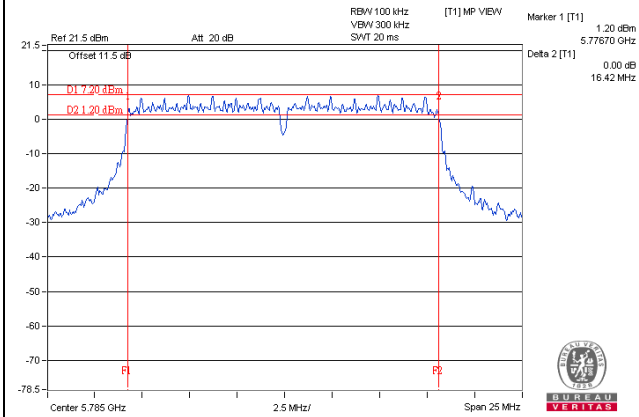

802.11n (HT20)

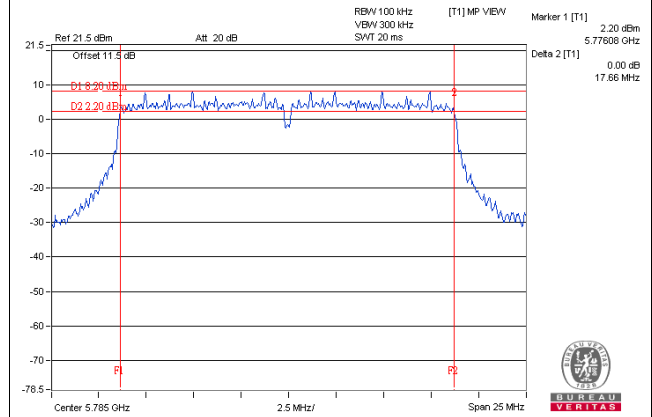

802.11n (HT40)

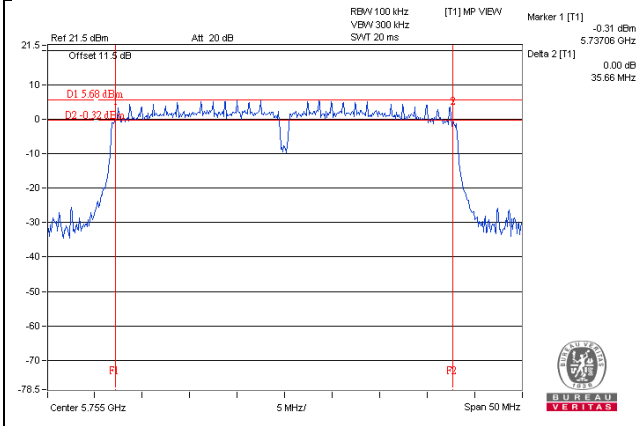

802.11ac (VHT80)

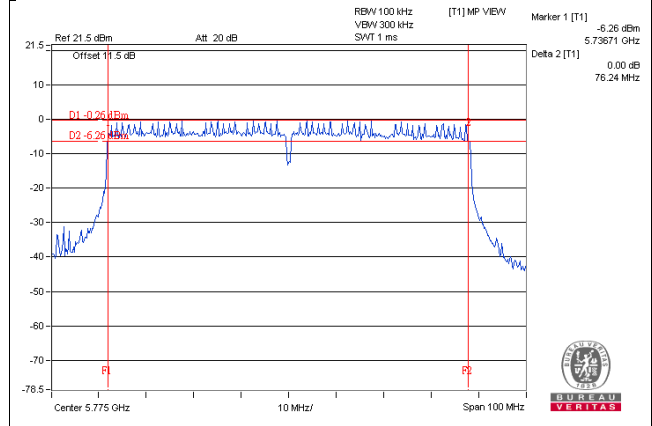

Test Mode C

802.11a

Channel	Frequency (MHz)	6dB Bandwidth (MHz)		Minimum Limit (MHz)	Pass / Fail
		Chain 0	Chain 1		
149	5745	16.39	16.37	0.5	Pass
157	5785	16.40	16.40	0.5	Pass
165	5825	16.41	16.39	0.5	Pass

802.11n (HT20)

Channel	Frequency (MHz)	6dB Bandwidth (MHz)		Minimum Limit (MHz)	Pass / Fail
		Chain 0	Chain 1		
149	5745	17.65	17.63	0.5	Pass
157	5785	17.64	17.62	0.5	Pass
165	5825	17.64	17.63	0.5	Pass

802.11n (HT40)

Channel	Frequency (MHz)	6dB Bandwidth (MHz)		Minimum Limit (MHz)	Pass / Fail
		Chain 0	Chain 1		
151	5755	35.53	35.29	0.5	Pass
159	5795	35.24	35.53	0.5	Pass

802.11ac (VHT80)

Channel	Frequency (MHz)	6dB Bandwidth (MHz)		Minimum Limit (MHz)	Pass / Fail
		Chain 0	Chain 1		
155	5775	76.07	76.40	0.5	Pass

Spectrum Plot of Worst Value

802.11a

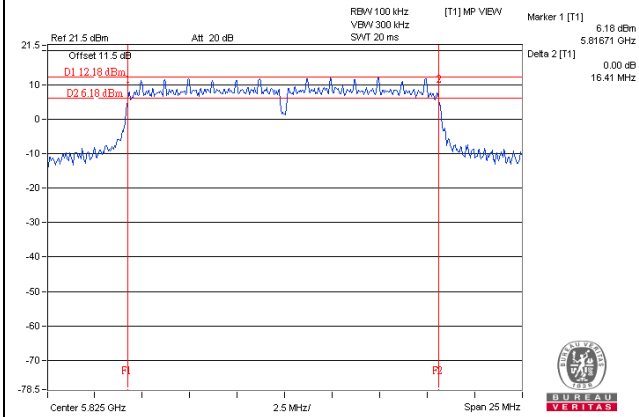

802.11n (HT20)

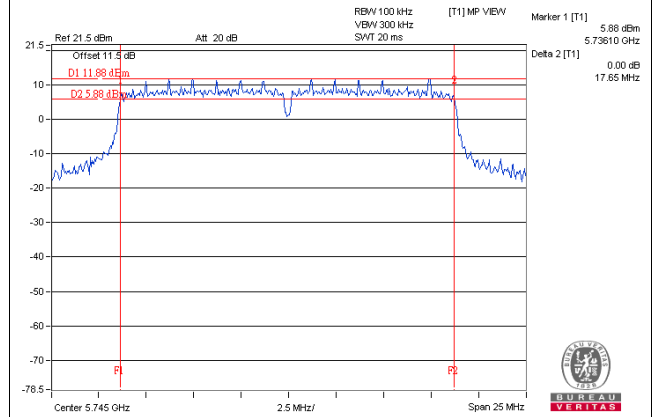

802.11n (HT40)

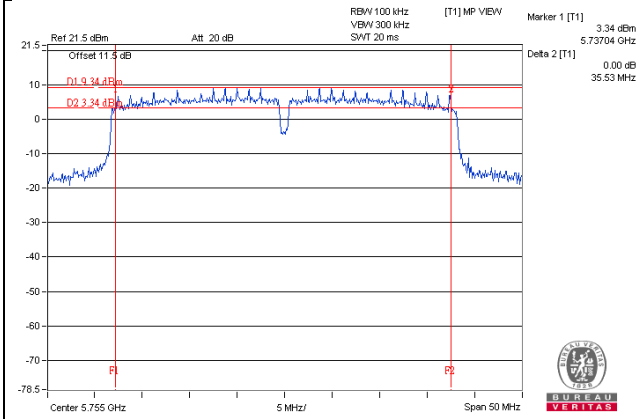

802.11ac (VHT80)

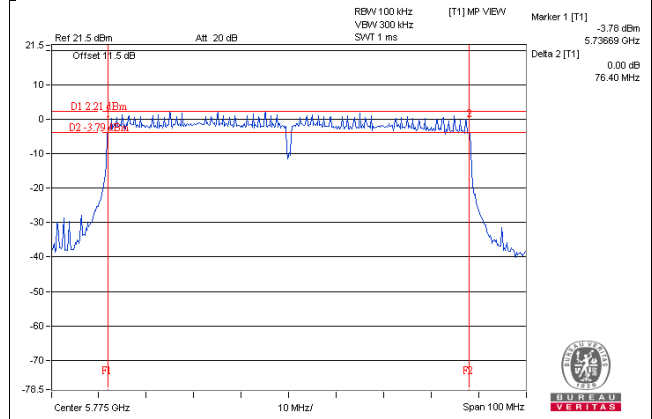

Test Mode D

802.11a

Channel	Frequency (MHz)	6dB Bandwidth (MHz)		Minimum Limit (MHz)	Pass / Fail
		Chain 0	Chain 1		
149	5745	16.40	16.38	0.5	Pass
157	5785	16.42	16.40	0.5	Pass
165	5825	16.41	16.39	0.5	Pass

802.11n (HT20)

Channel	Frequency (MHz)	6dB Bandwidth (MHz)		Minimum Limit (MHz)	Pass / Fail
		Chain 0	Chain 1		
149	5745	17.66	17.63	0.5	Pass
157	5785	17.65	17.63	0.5	Pass
165	5825	17.64	17.63	0.5	Pass

802.11n (HT40)

Channel	Frequency (MHz)	6dB Bandwidth (MHz)		Minimum Limit (MHz)	Pass / Fail
		Chain 0	Chain 1		
151	5755	35.53	35.46	0.5	Pass
159	5795	35.51	35.87	0.5	Pass

802.11ac (VHT80)

Channel	Frequency (MHz)	6dB Bandwidth (MHz)		Minimum Limit (MHz)	Pass / Fail
		Chain 0	Chain 1		
155	5775	76.49	76.33	0.5	Pass

Spectrum Plot of Worst Value

802.11a

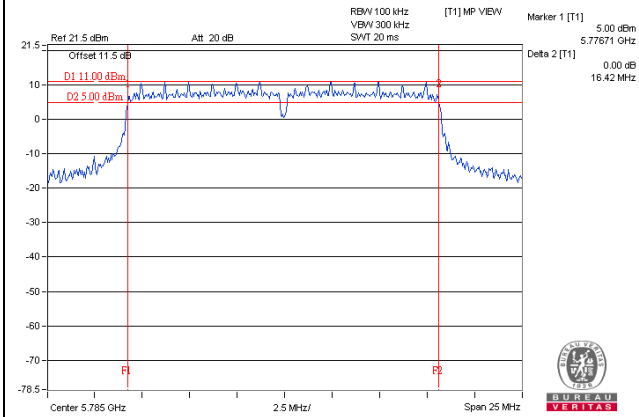

802.11n (HT20)

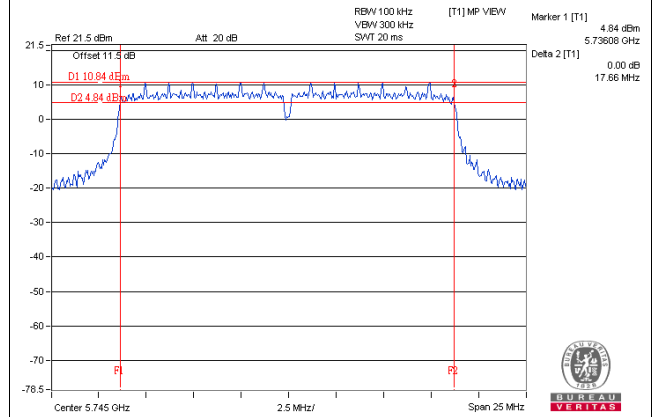

802.11n (HT40)

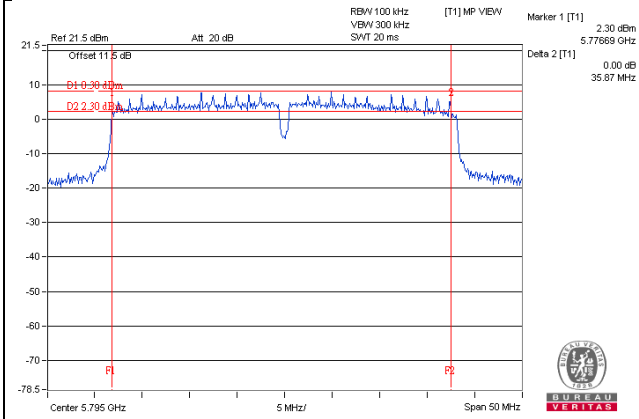

802.11ac (VHT80)

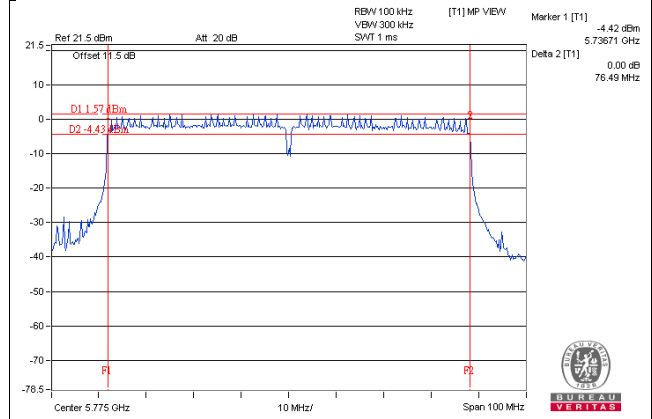

Test Mode E

802.11a

Channel	Frequency (MHz)	6dB Bandwidth (MHz)		Minimum Limit (MHz)	Pass / Fail
		Chain 0	Chain 1		
149	5745	16.41	16.43	0.5	Pass
157	5785	16.42	16.40	0.5	Pass
165	5825	16.42	16.40	0.5	Pass

802.11n (HT20)

Channel	Frequency (MHz)	6dB Bandwidth (MHz)		Minimum Limit (MHz)	Pass / Fail
		Chain 0	Chain 1		
149	5745	17.67	17.67	0.5	Pass
157	5785	17.66	17.65	0.5	Pass
165	5825	17.68	17.66	0.5	Pass

802.11n (HT40)

Channel	Frequency (MHz)	6dB Bandwidth (MHz)		Minimum Limit (MHz)	Pass / Fail
		Chain 0	Chain 1		
151	5755	35.58	35.46	0.5	Pass
159	5795	35.30	35.55	0.5	Pass

802.11ac (VHT80)

Channel	Frequency (MHz)	6dB Bandwidth (MHz)		Minimum Limit (MHz)	Pass / Fail
		Chain 0	Chain 1		
155	5775	76.05	75.90	0.5	Pass

Spectrum Plot of Worst Value

802.11a

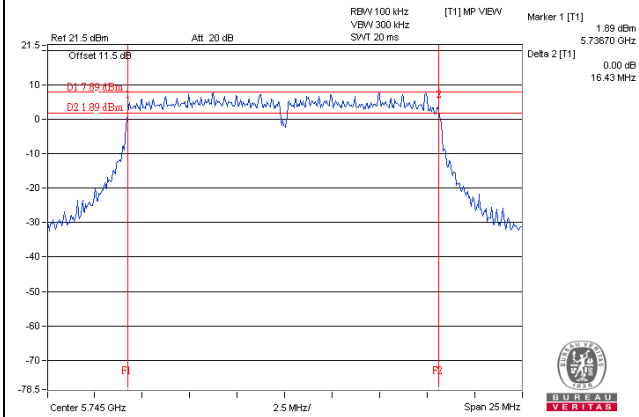

802.11n (HT20)

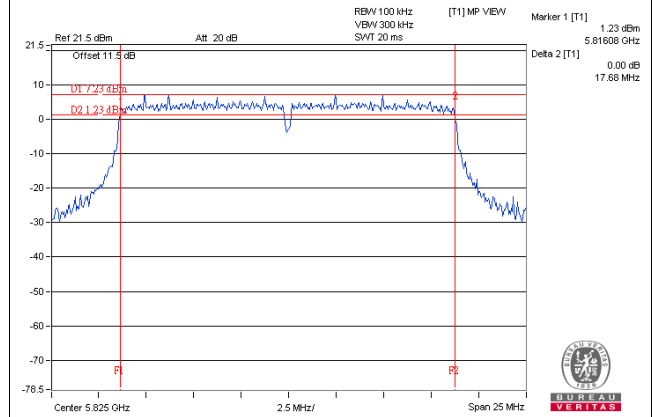

802.11n (HT40)

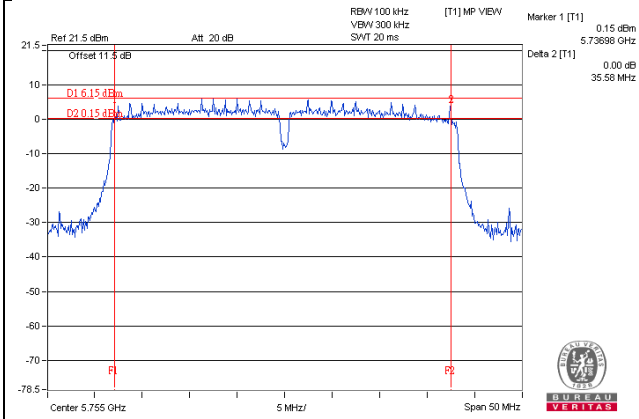

802.11ac (VHT80)

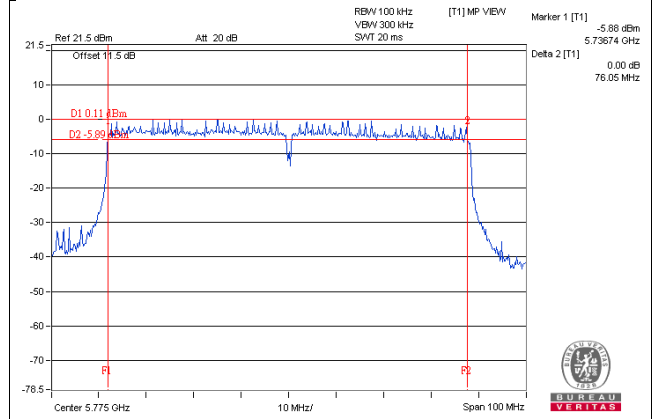

Test Mode F

802.11a

Channel	Frequency (MHz)	6dB Bandwidth (MHz)	Minimum Limit (MHz)	Pass / Fail
149	5745	16.34	0.5	Pass
157	5785	16.33	0.5	Pass
165	5825	16.36	0.5	Pass

802.11n (HT20)

Channel	Frequency (MHz)	6dB Bandwidth (MHz)	Minimum Limit (MHz)	Pass / Fail
149	5745	17.30	0.5	Pass
157	5785	17.60	0.5	Pass
165	5825	17.62	0.5	Pass

802.11n (HT40)

Channel	Frequency (MHz)	6dB Bandwidth (MHz)	Minimum Limit (MHz)	Pass / Fail
151	5755	35.95	0.5	Pass
159	5795	35.80	0.5	Pass

802.11ac (VHT80)

Channel	Frequency (MHz)	6dB Bandwidth (MHz)	Minimum Limit (MHz)	Pass / Fail
155	5775	71.53	0.5	Pass

Spectrum Plot of Worst Value

802.11a

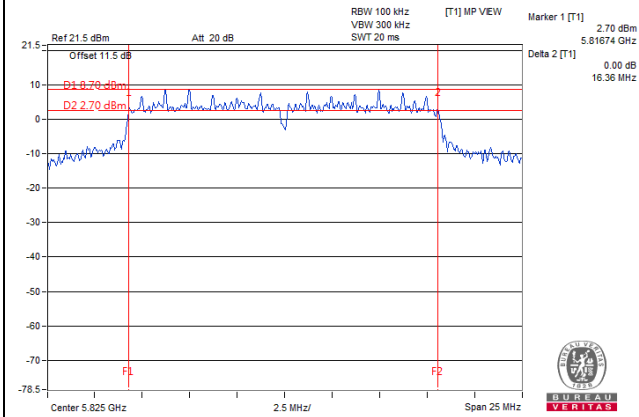

802.11n (HT20)

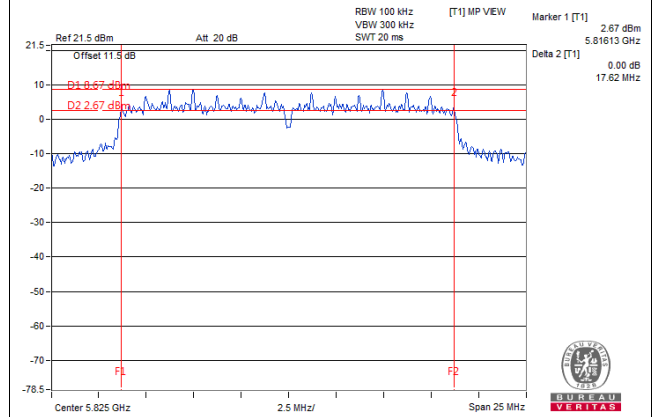

802.11n (HT40)

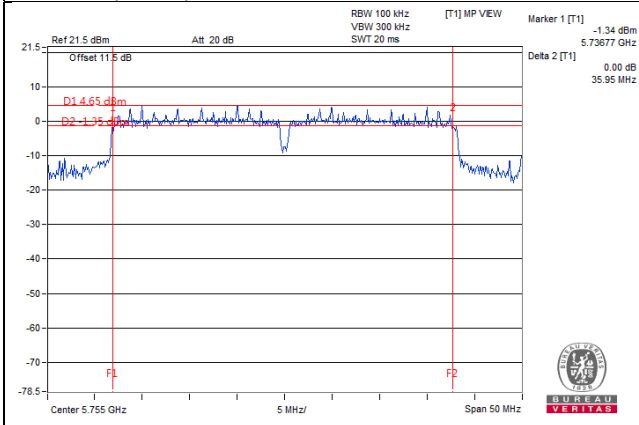

802.11ac (VHT80)

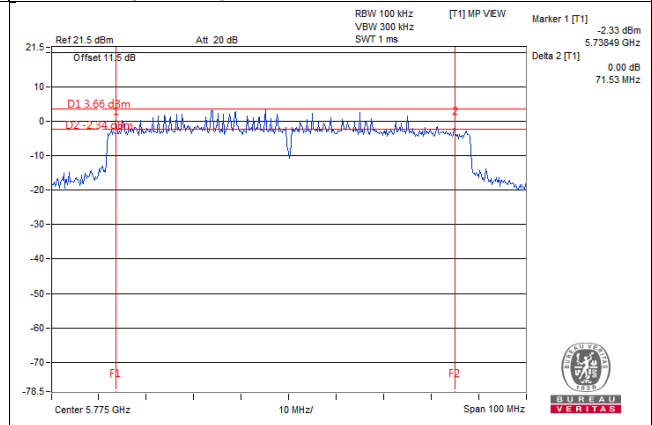

5 Pictures of Test Arrangements

Please refer to the attached file (Test Setup Photo).

Annex A- Radiated Out of Band Emission (OOBE) Measurement (For U-NII-3 band)

Test Mode A

802.11a

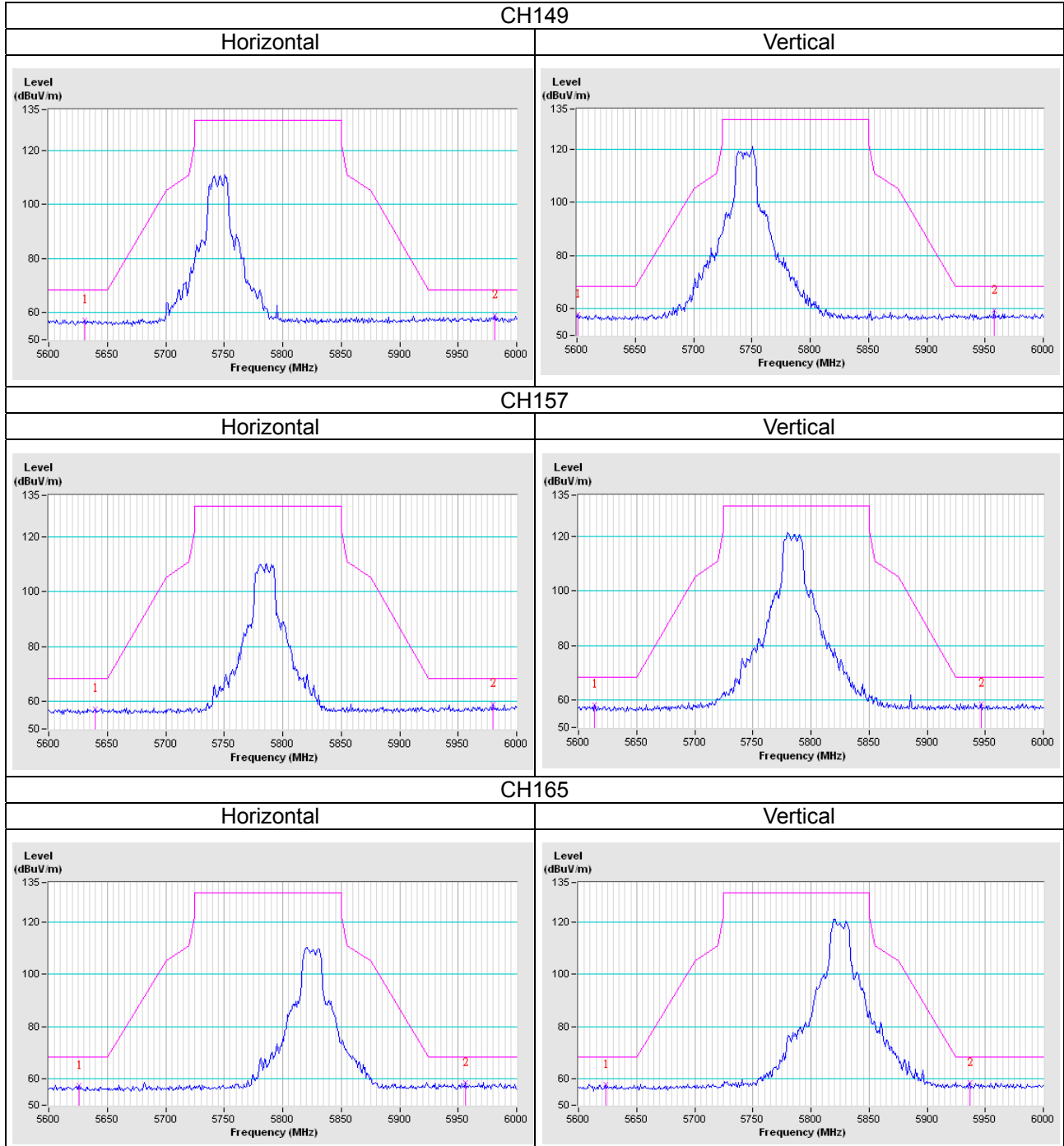

802.11n (HT20)

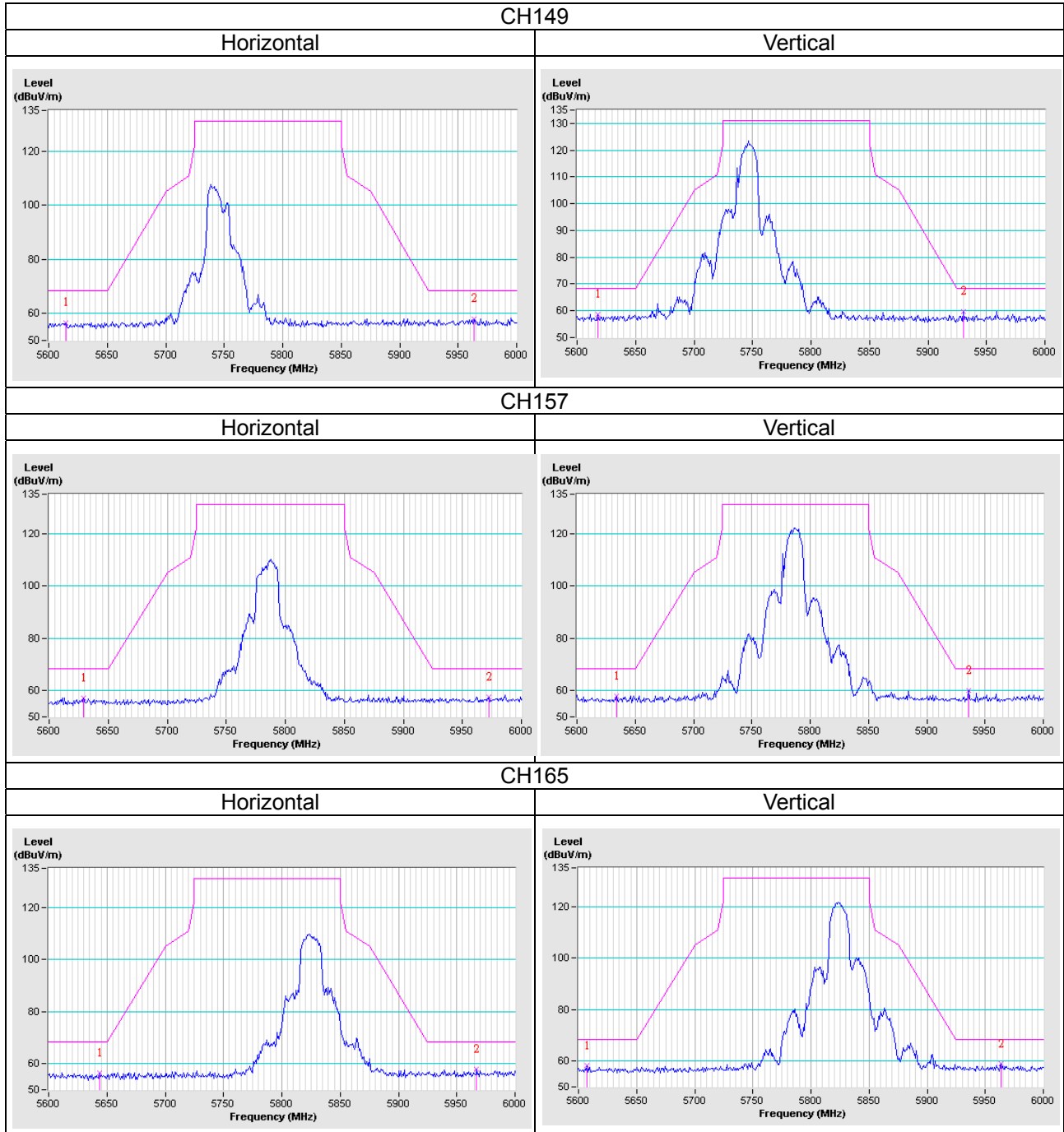

802.11n (HT40)

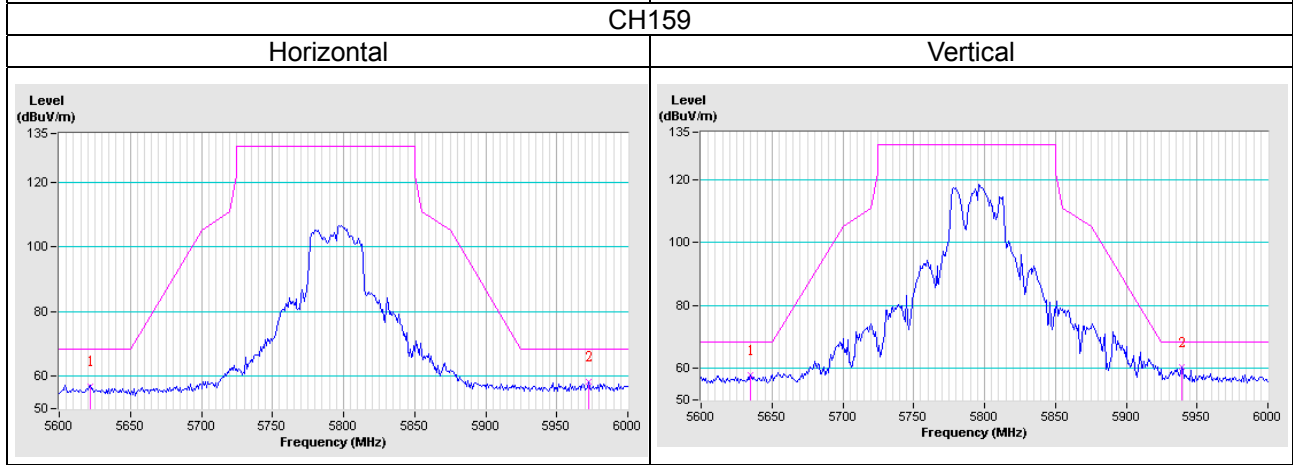
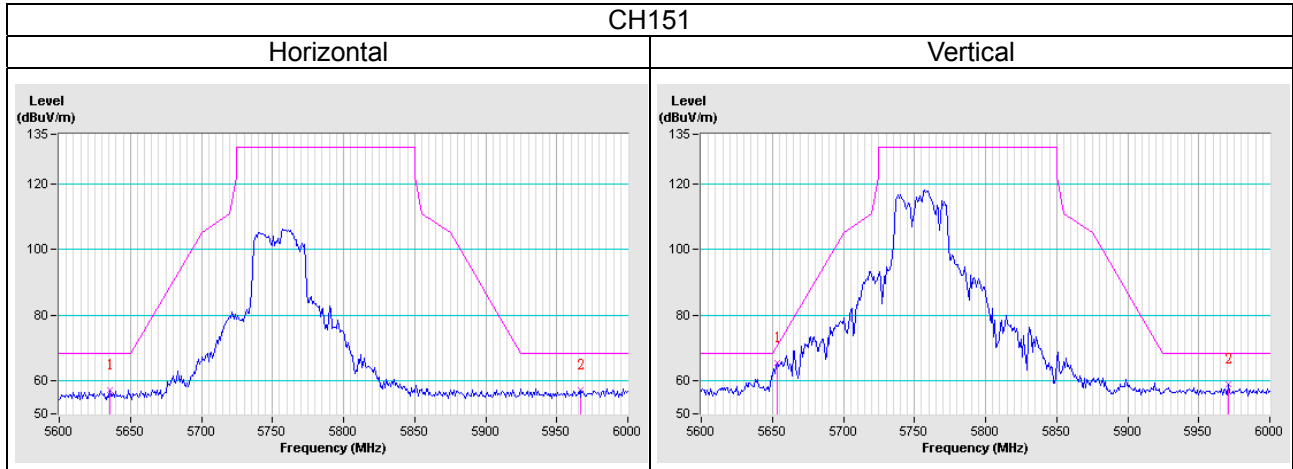

802.11ac (VHT80)

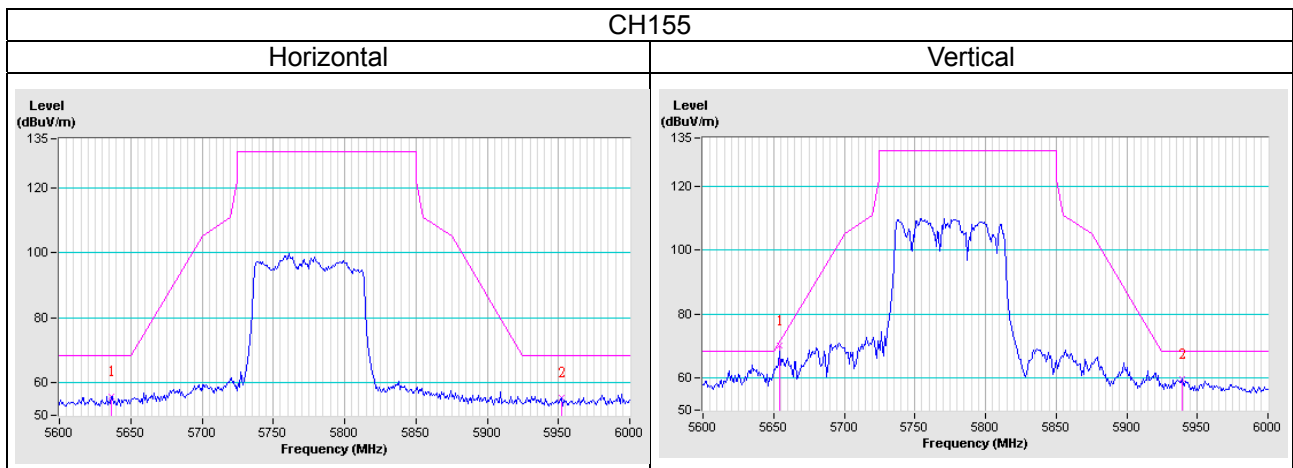

Test Mode B

802.11a

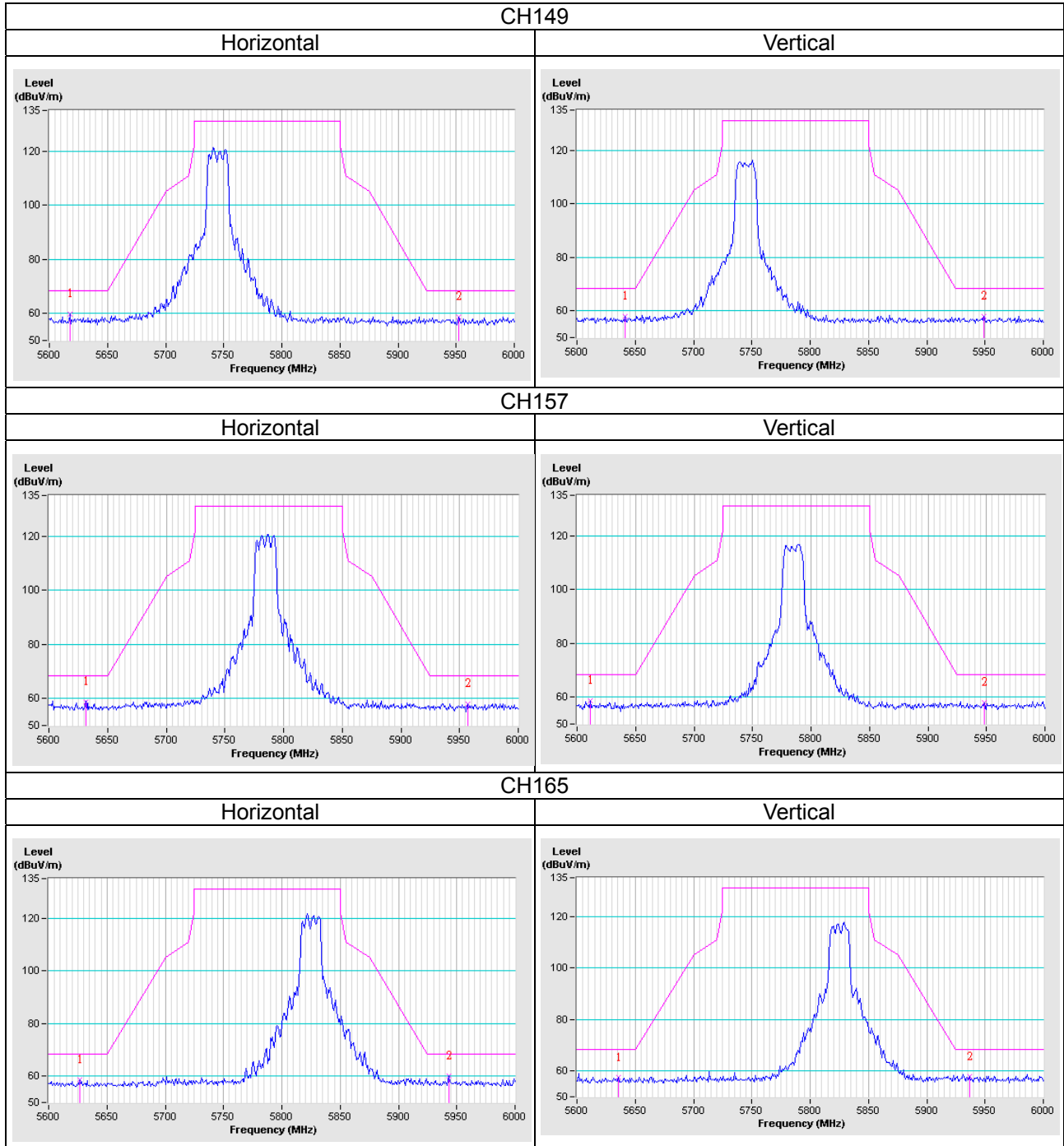

802.11n (HT20)

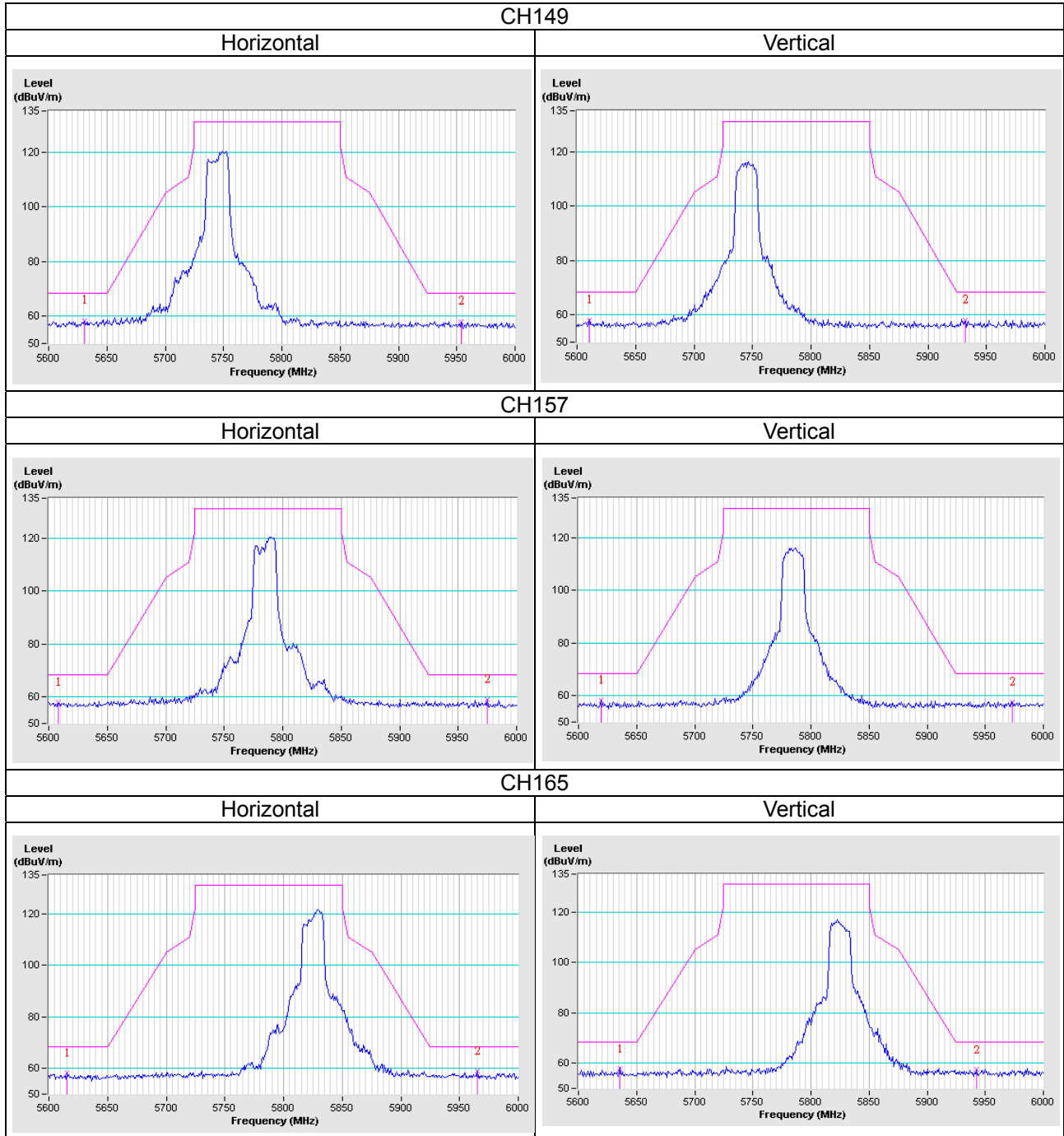

802.11n (HT40)

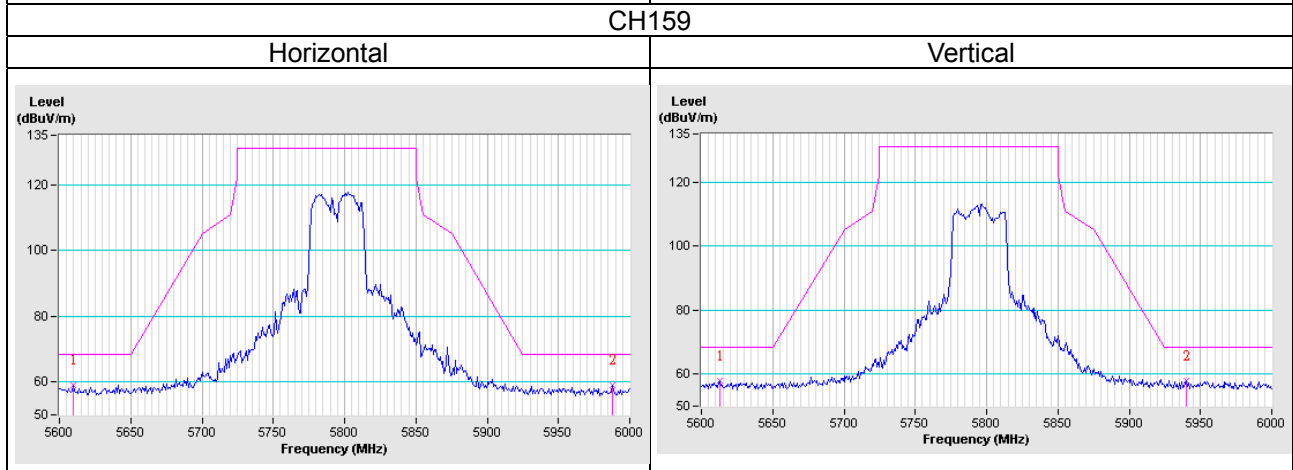
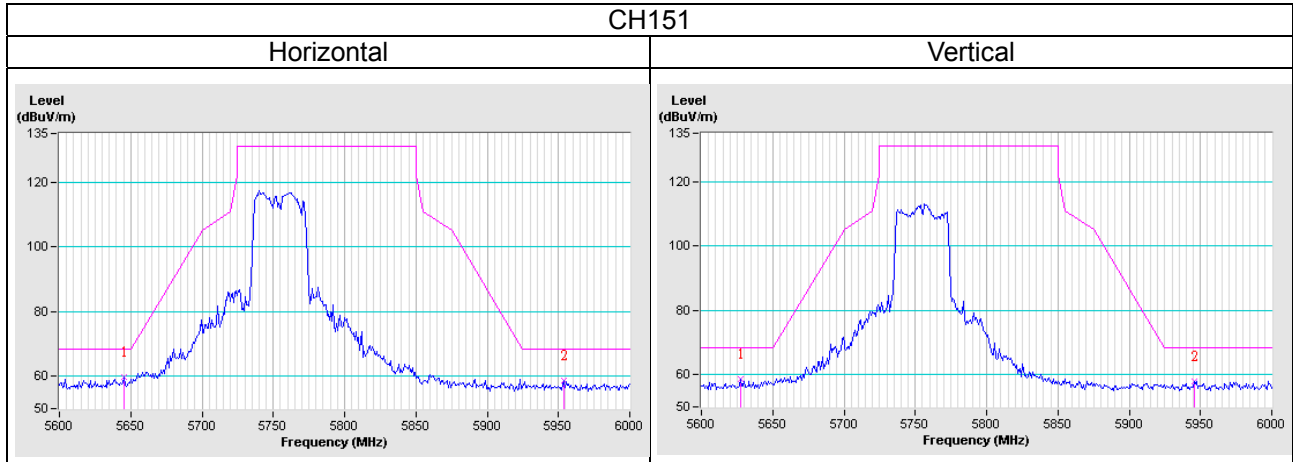

802.11ac (VHT80)

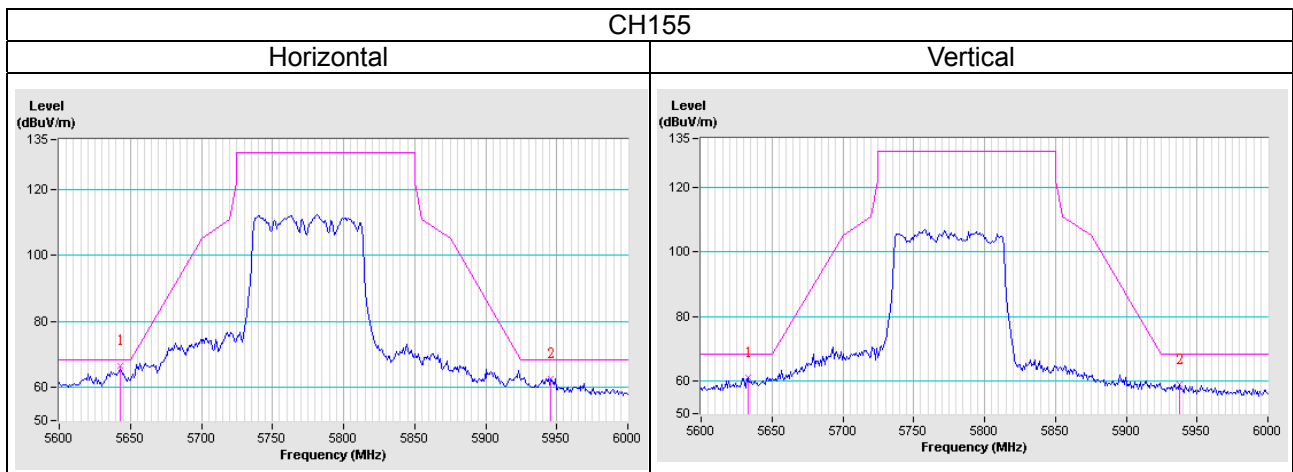

Test Mode C

802.11a

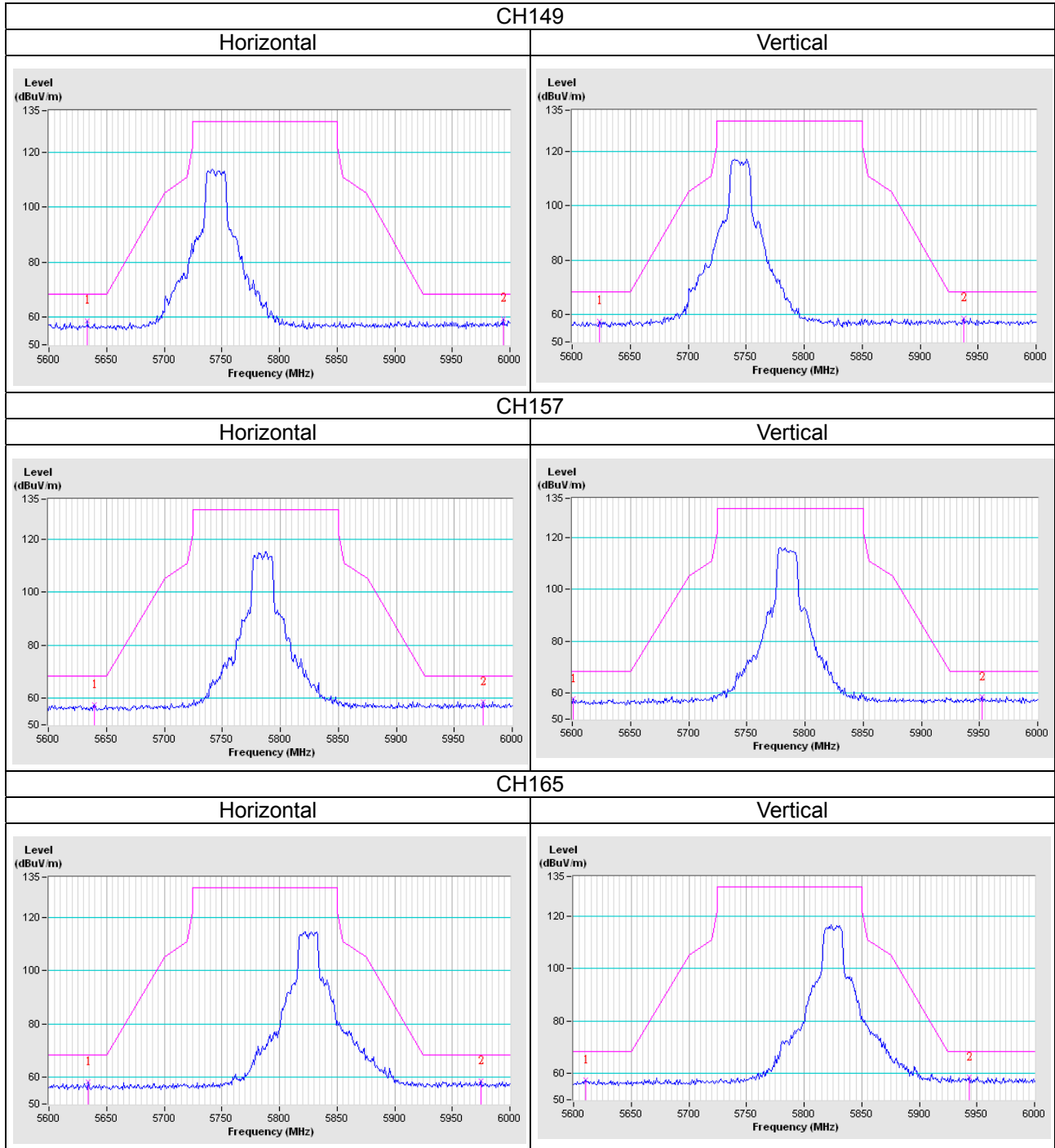

802.11n (HT20)

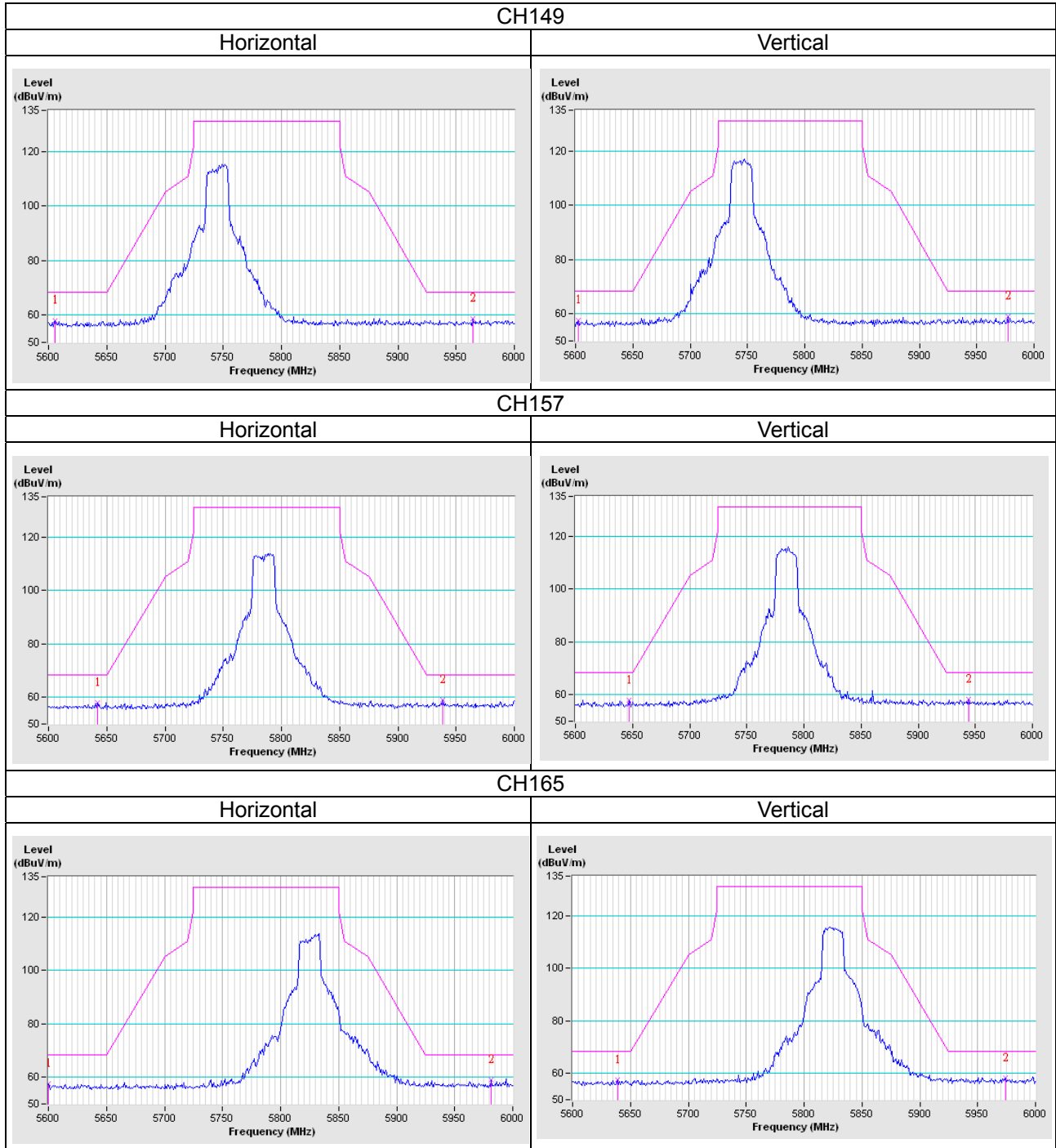

802.11n (HT40)

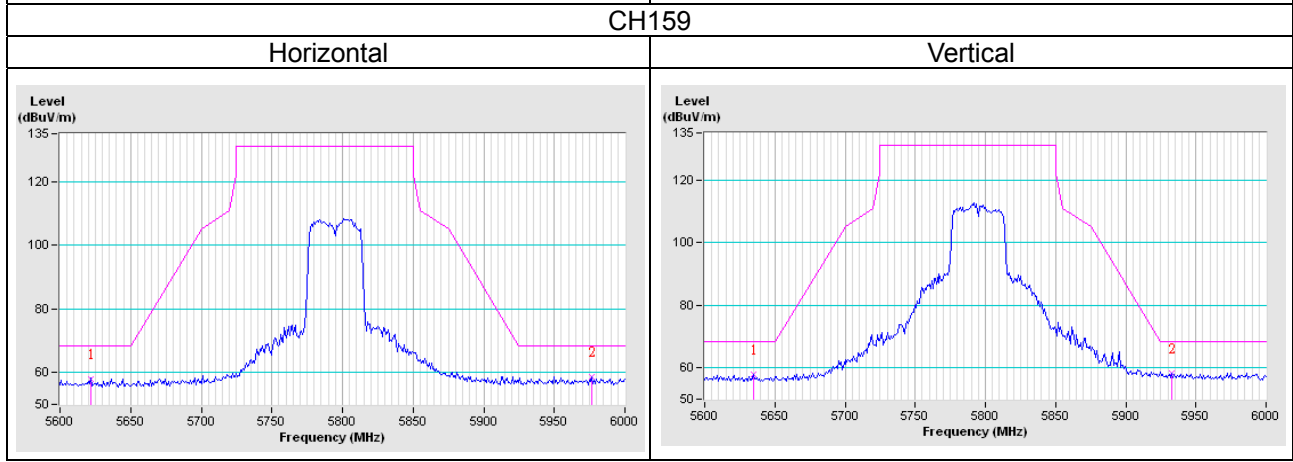
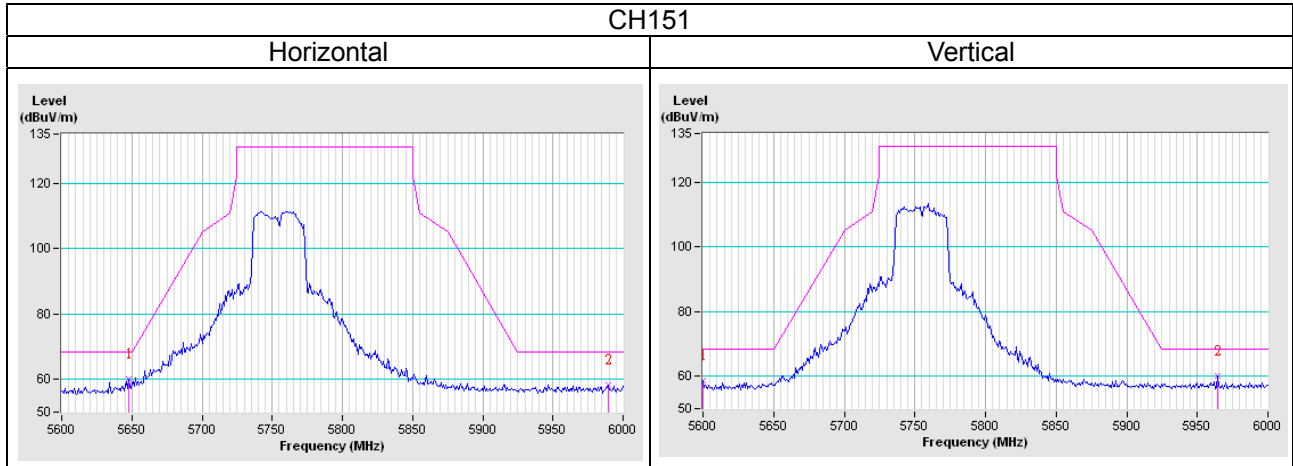

802.11ac (VHT80)

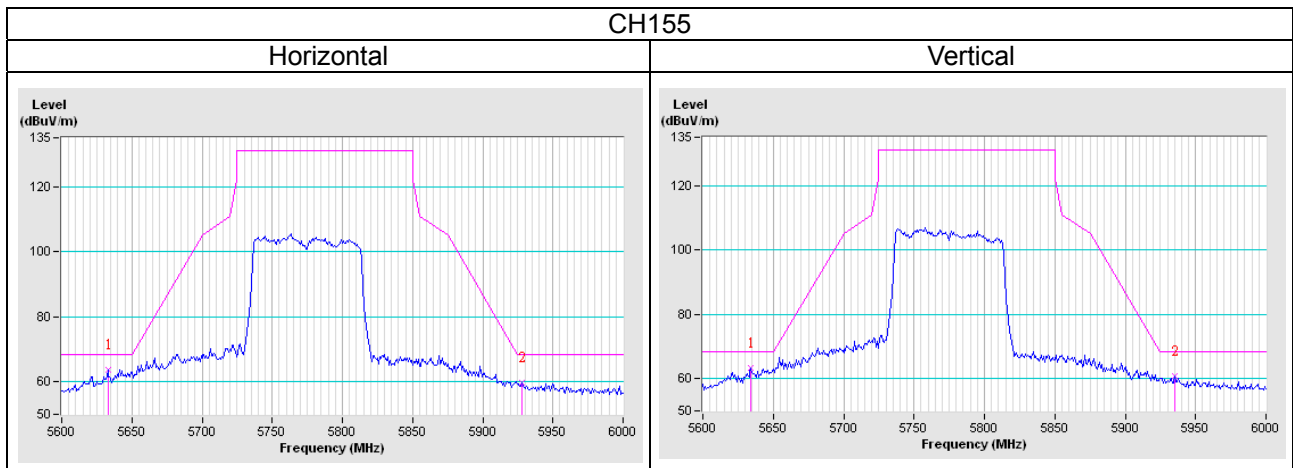

Test Mode D

802.11a

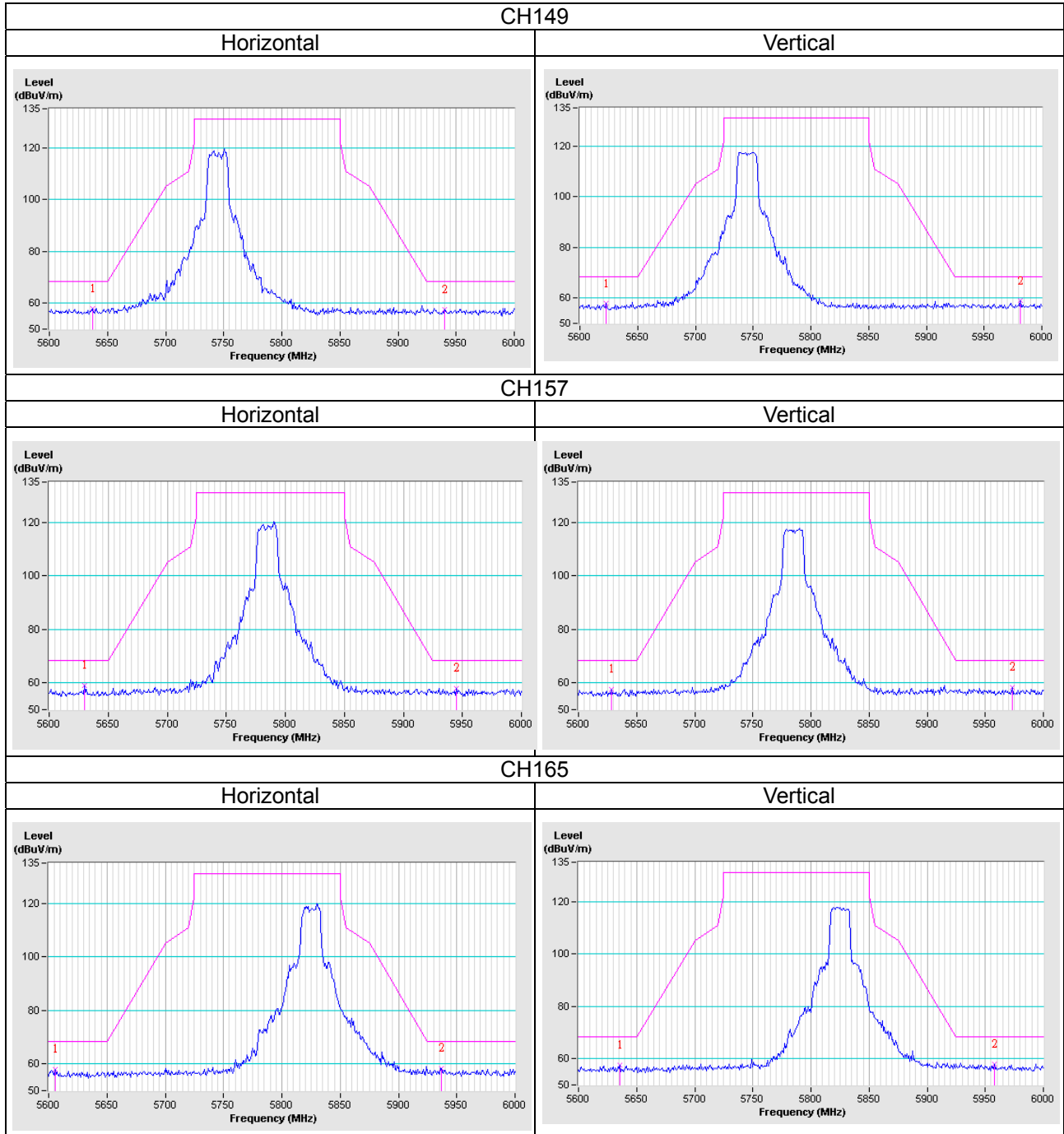

802.11n (HT20)

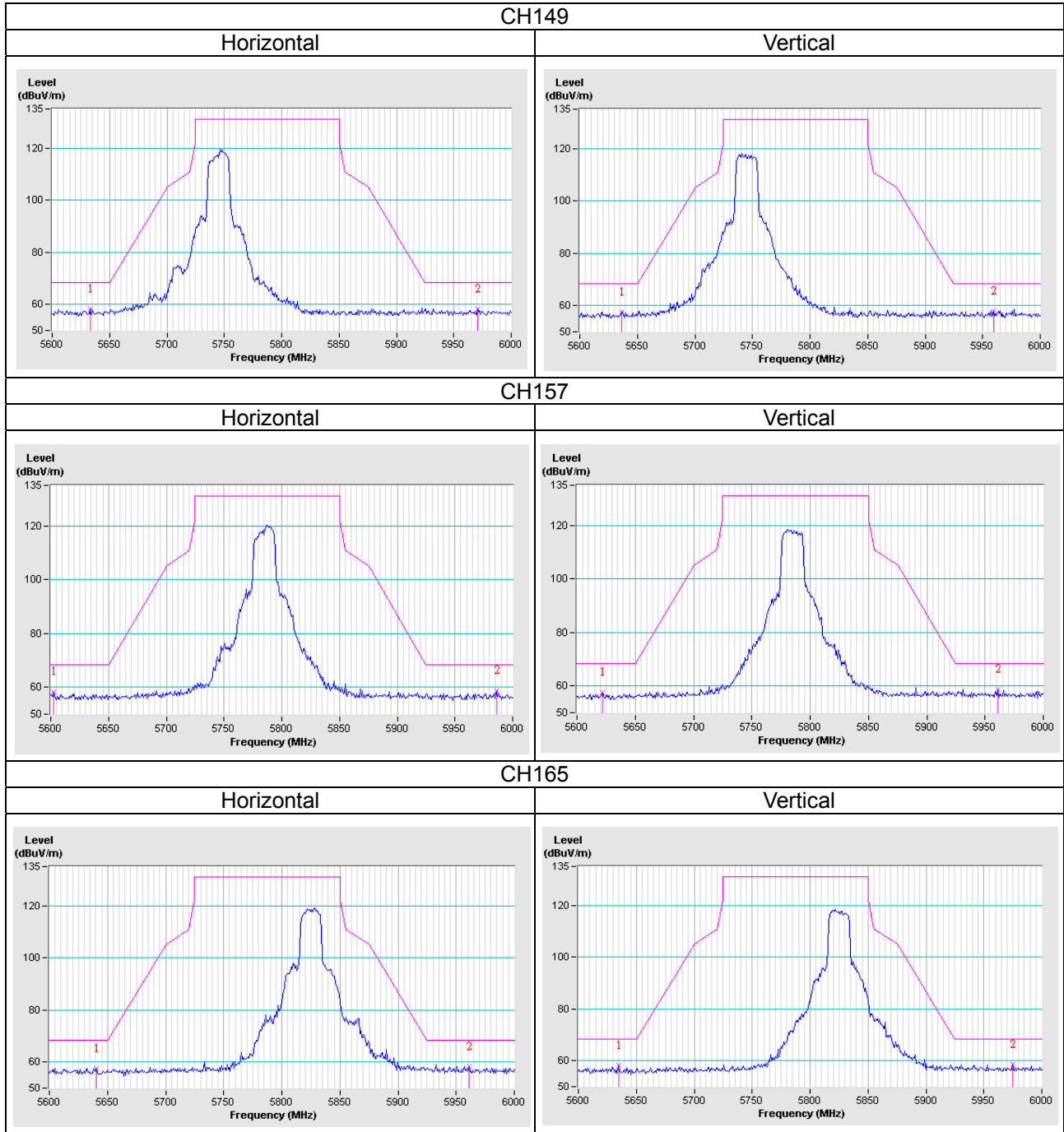

802.11n (HT40)

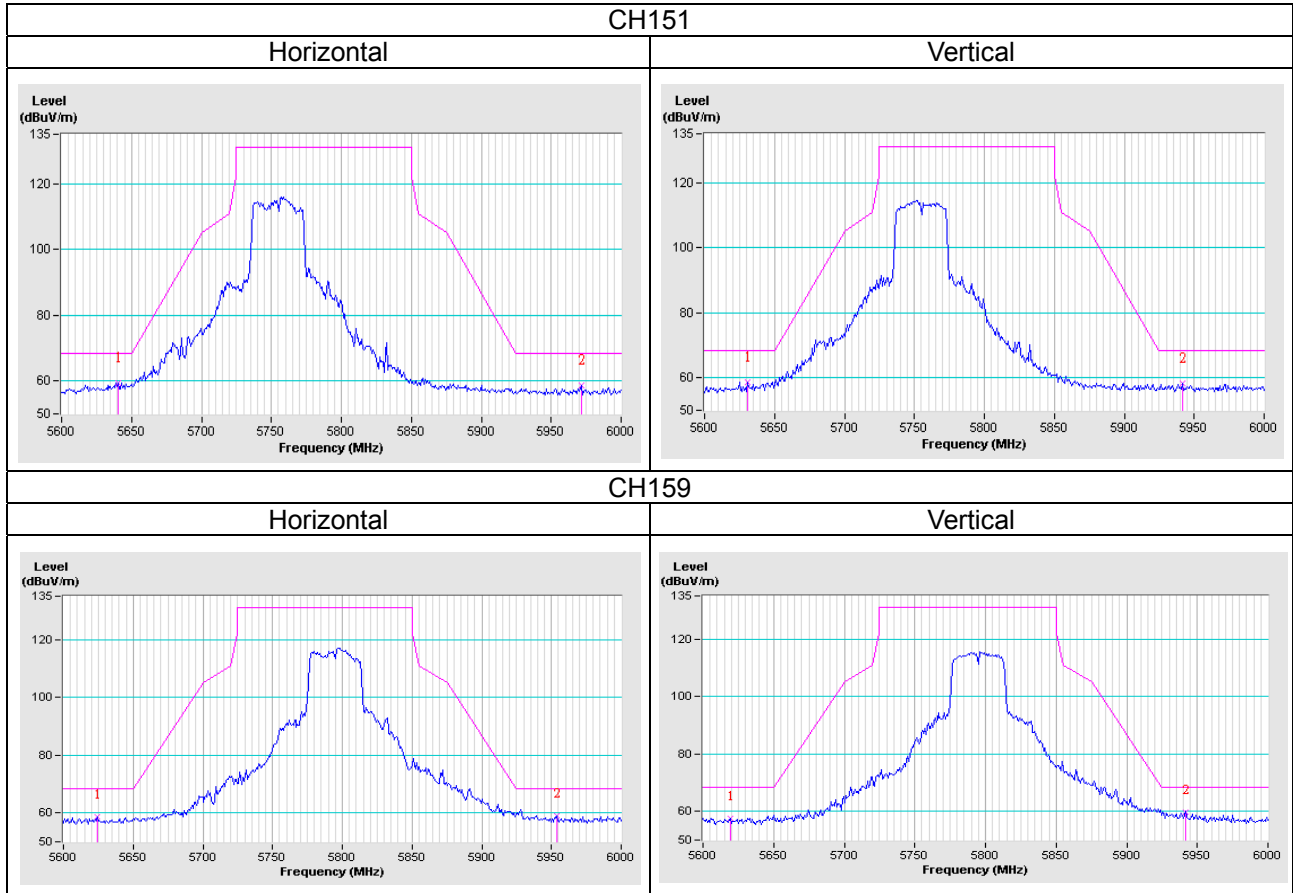

802.11ac (VHT80)

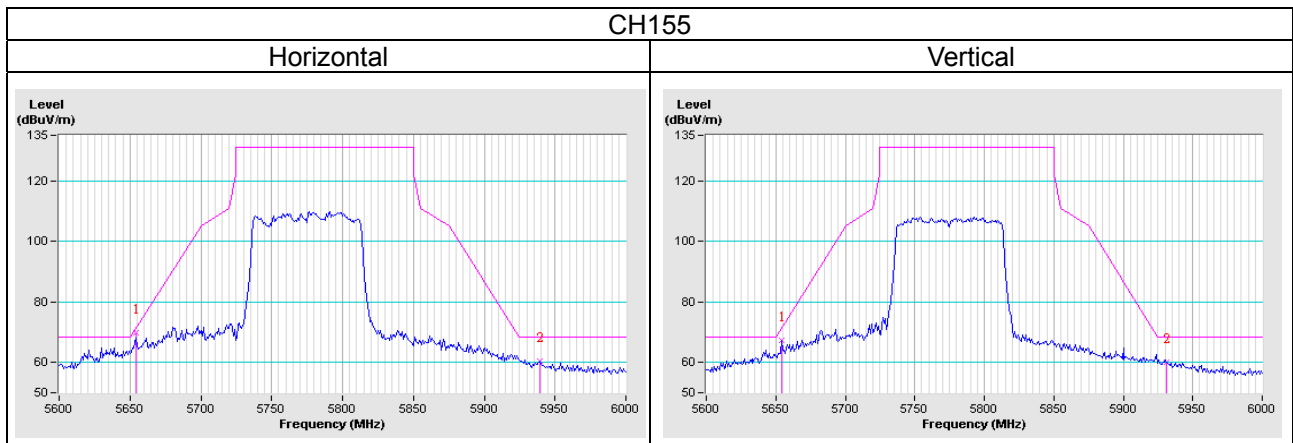

Test Mode E

802.11a

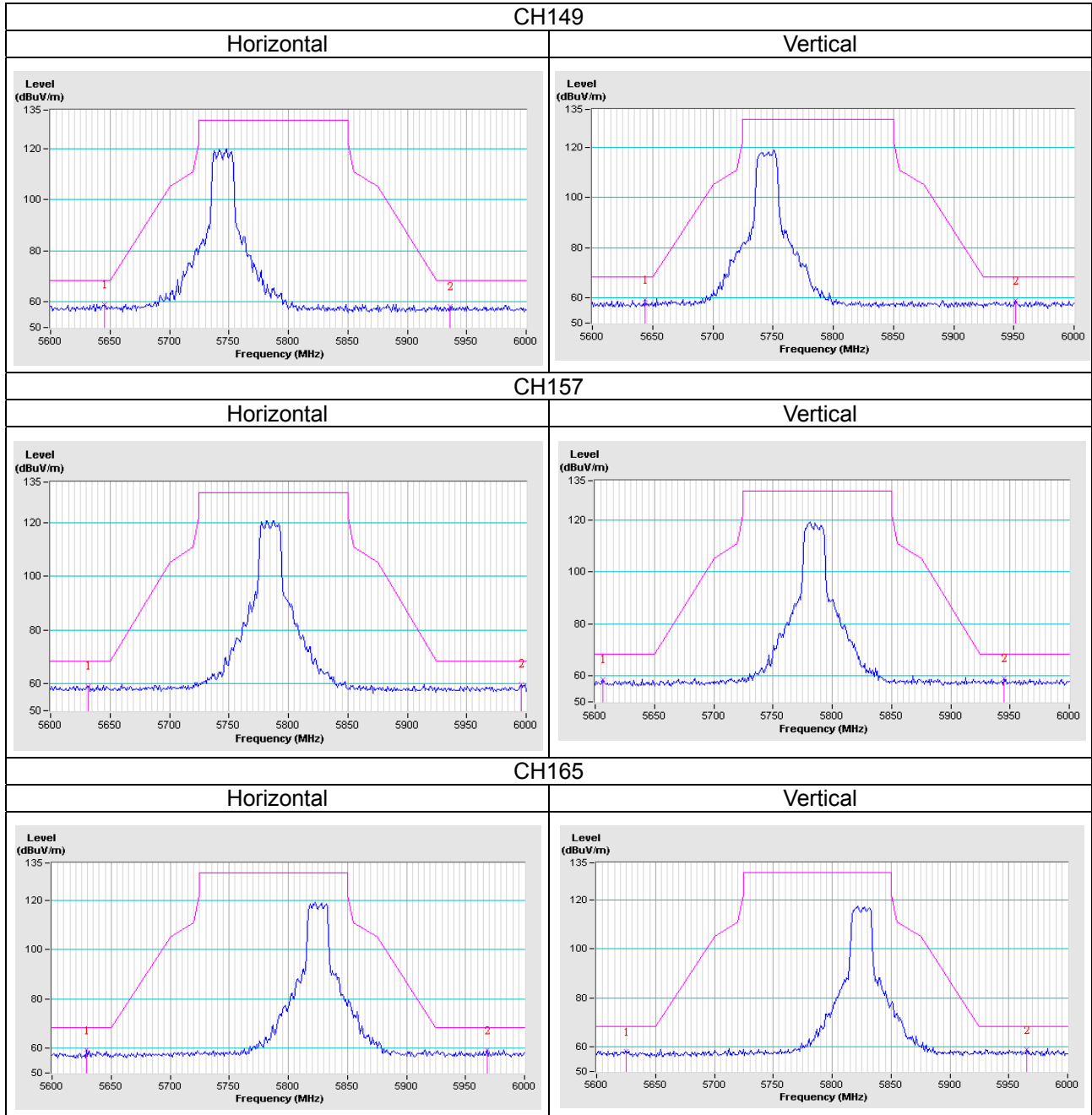

802.11n (HT20)

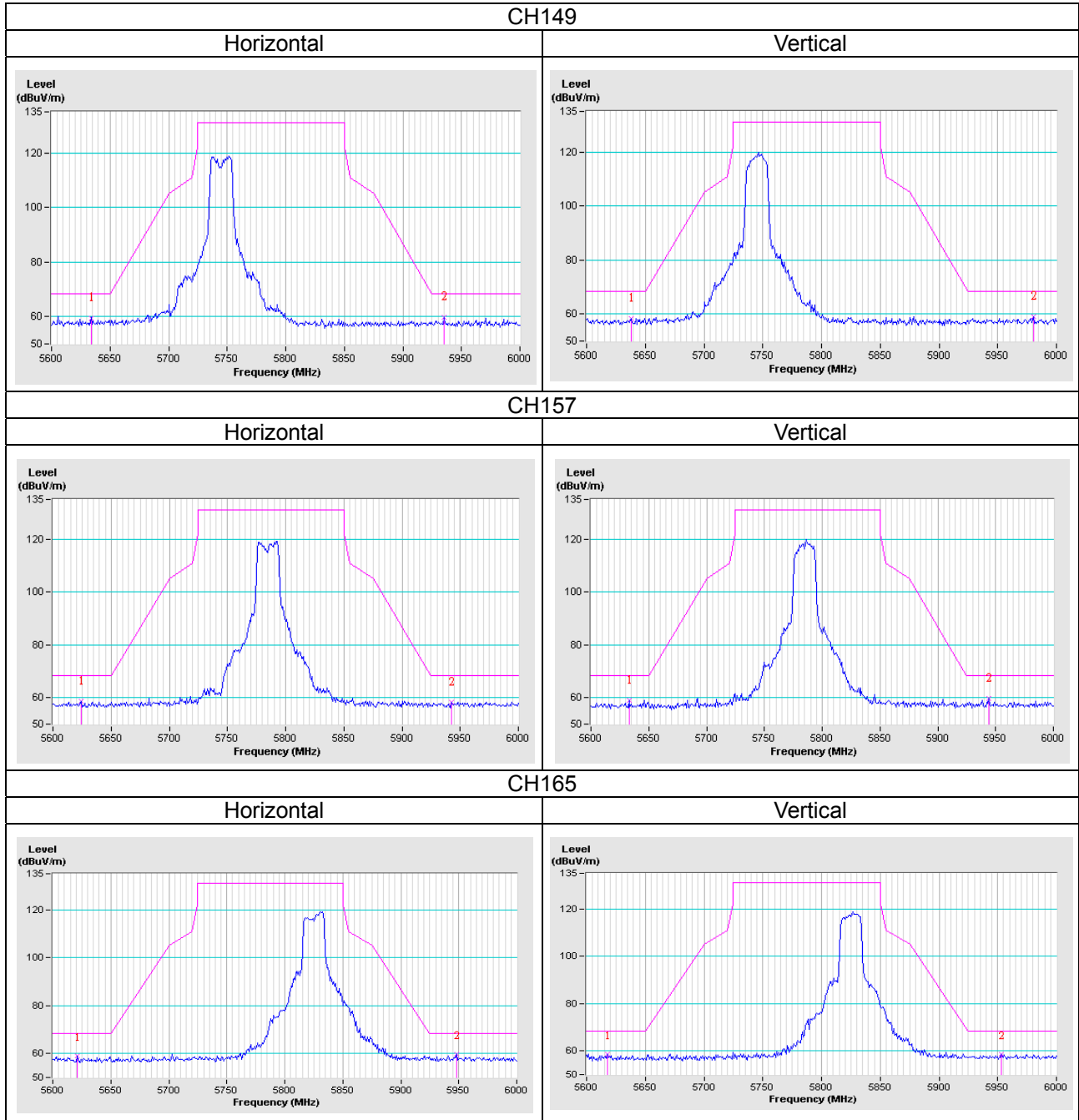

802.11n (HT40)

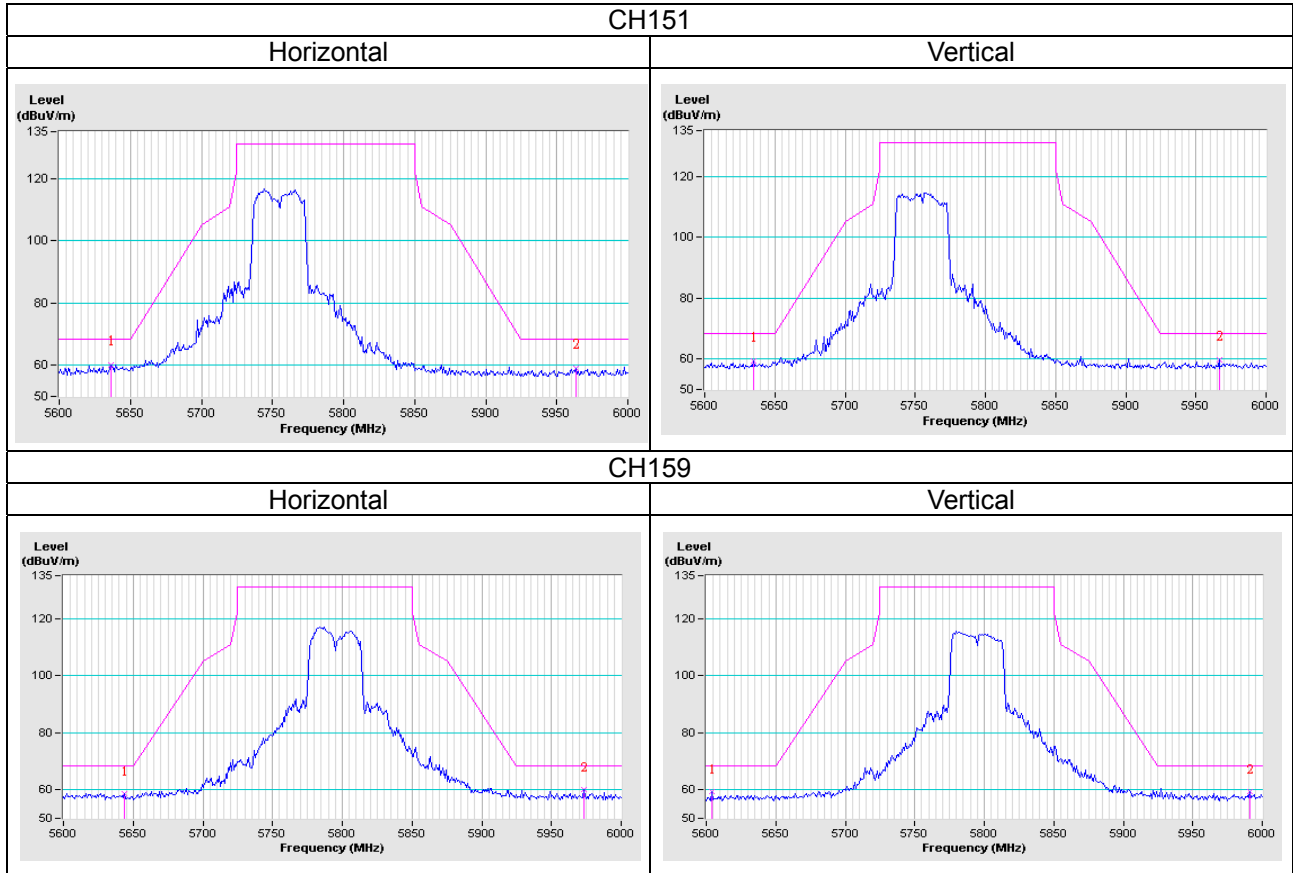

802.11ac (VHT80)

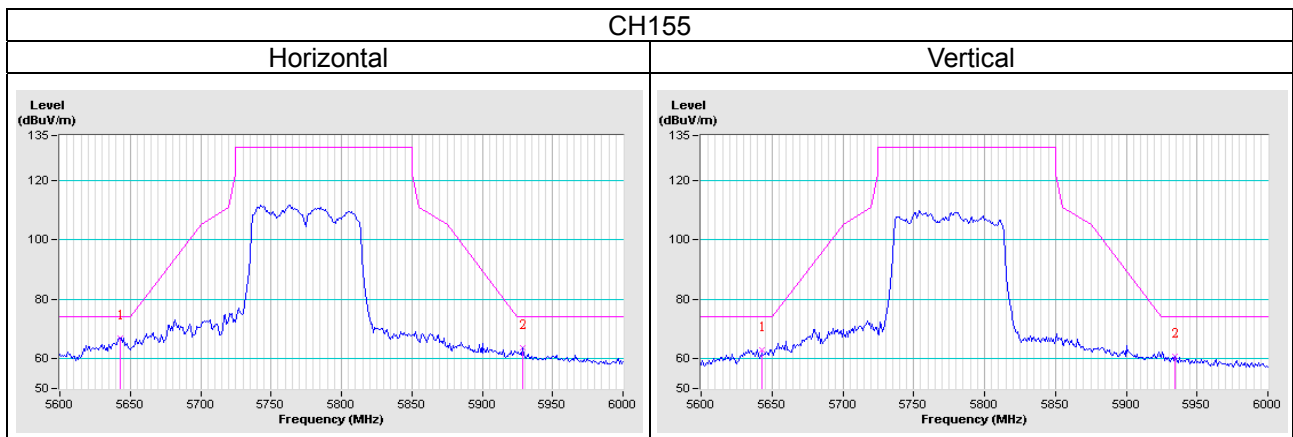

Test Mode F

802.11a

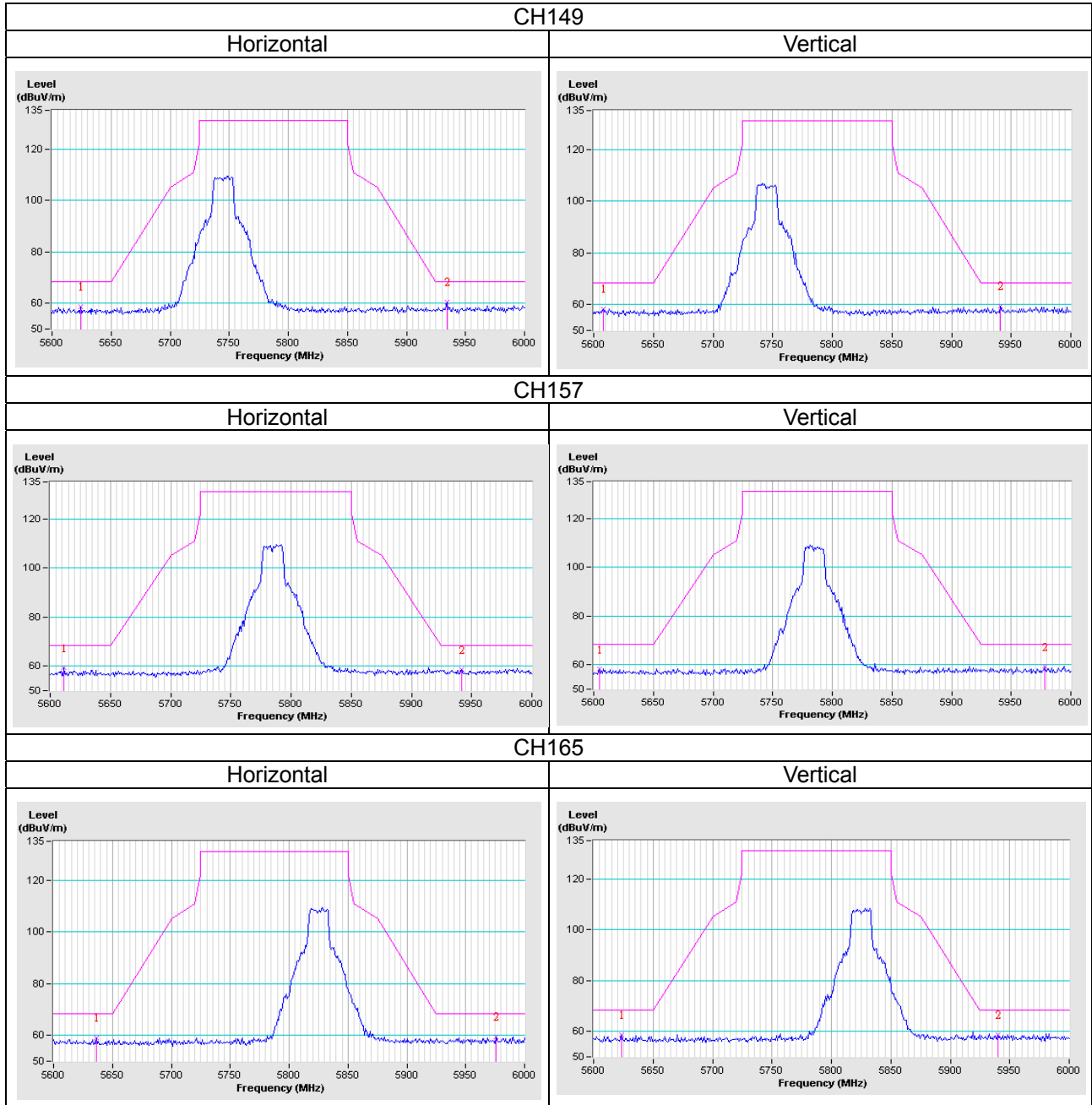

802.11n (HT20)

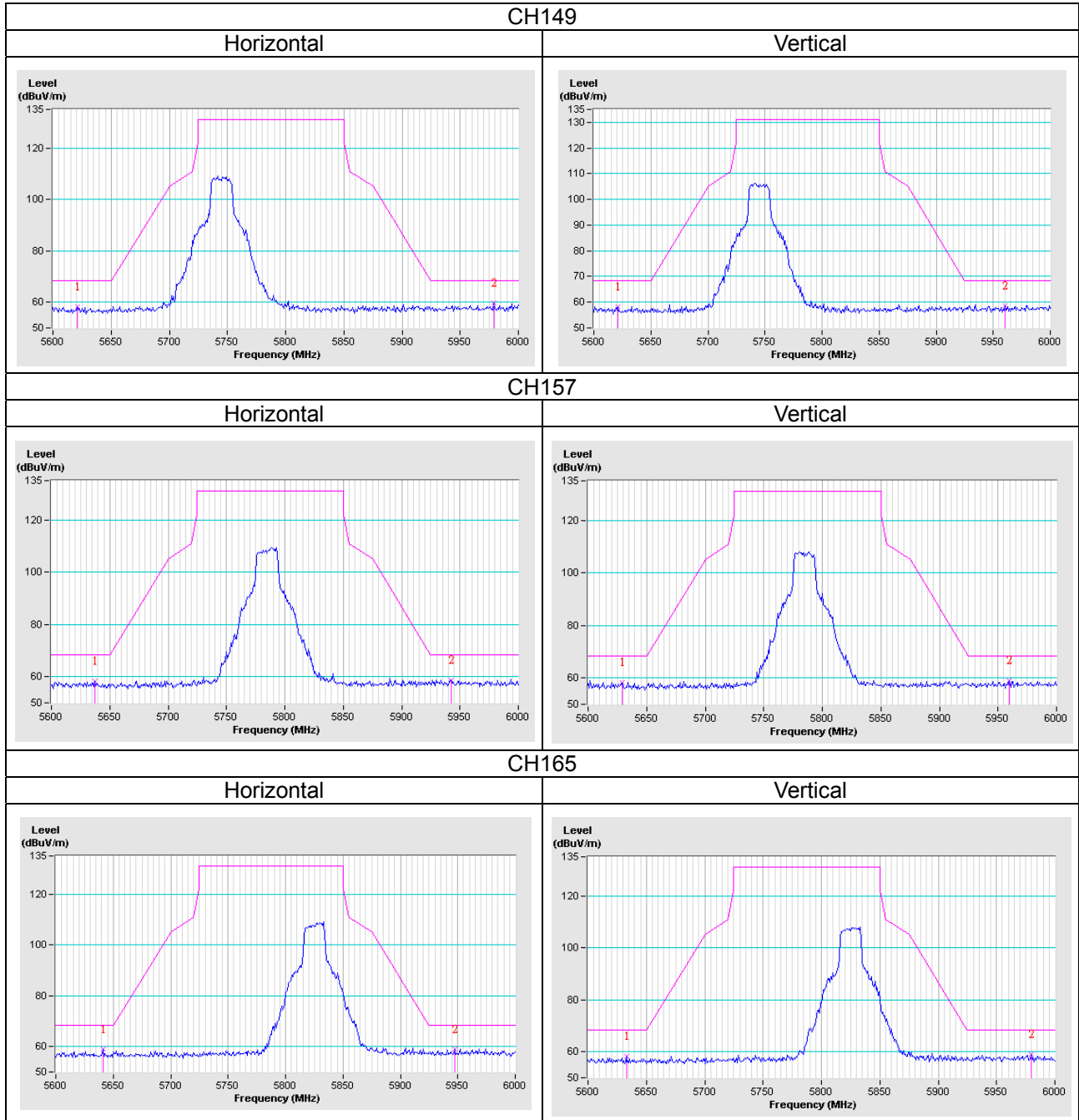

802.11n (HT40)

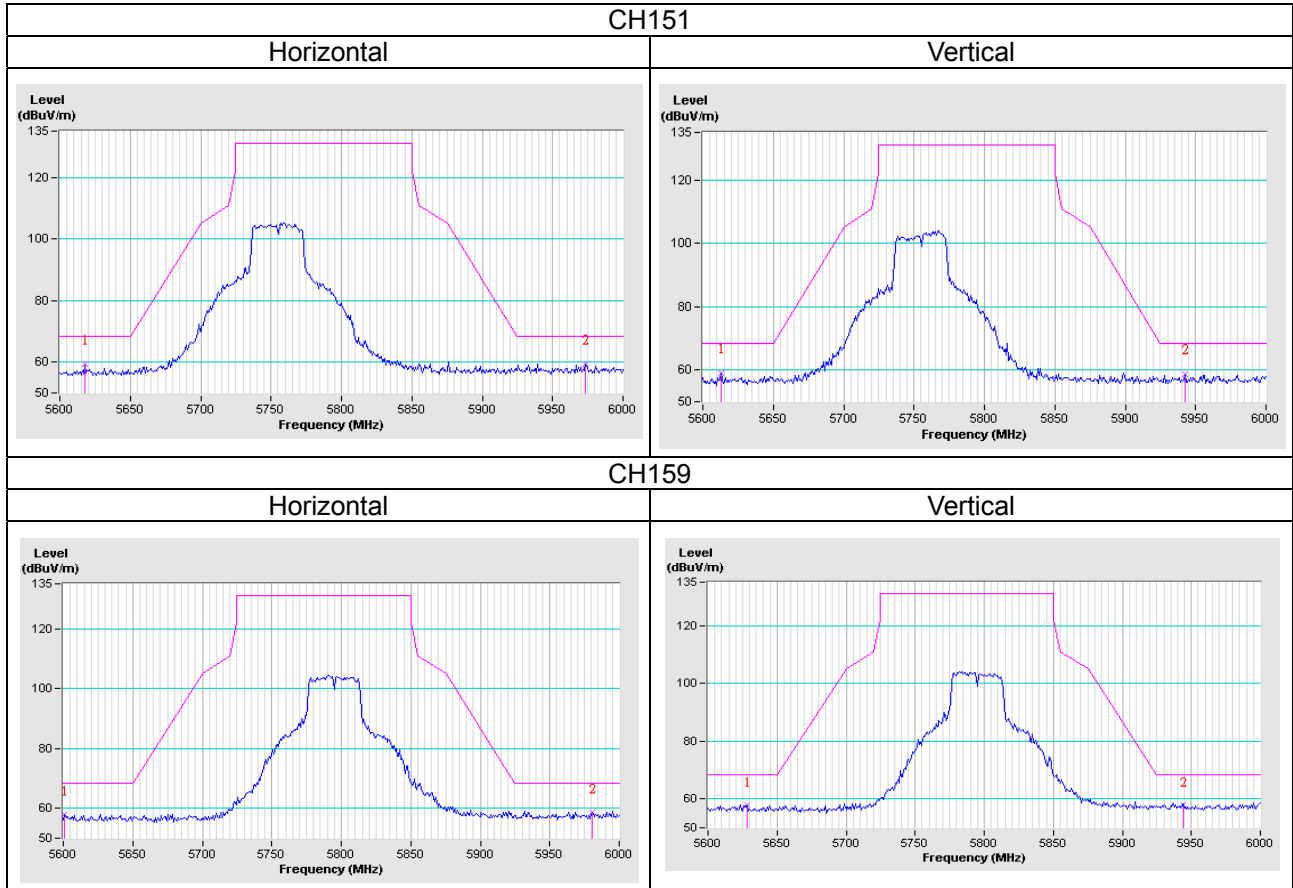

802.11ac (VHT80)

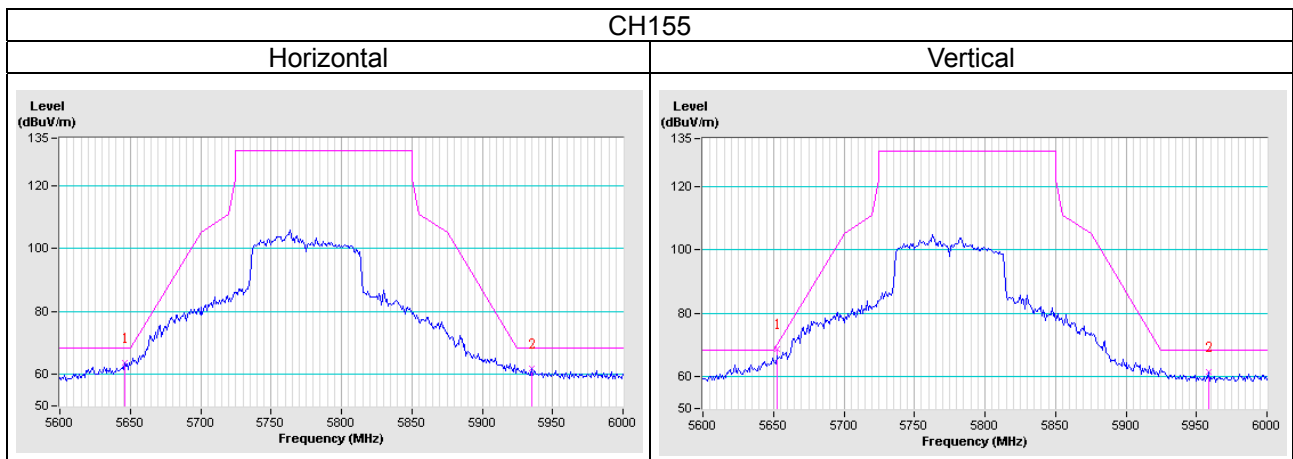

Appendix – Information on the Testing Laboratories

We, Bureau Veritas Consumer Products Services (H.K.) Ltd., Taoyuan Branch, were founded in 1988 to provide our best service in EMC, Radio, Telecom and Safety consultation. Our laboratories are accredited and approved according to ISO/IEC 17025.

If you have any comments, please feel free to contact us at the following:

Linko EMC/RF Lab

Tel: 886-2-26052180

Fax: 886-2-26051924

Hsin Chu EMC/RF/Telecom Lab

Tel: 886-3-6668565

Fax: 886-3-6668323

Hwa Ya EMC/RF/Safety Lab

Tel: 886-3-3183232

Fax: 886-3-3270892

Email: service.adt@tw.bureauveritas.com

Web Site: www.bureauveritas-adt.com

The address and road map of all our labs can be found in our web site also.

--- END ---