

FCC Test Report

Report No.: RF160725C02

FCC ID: UDX-60052010

Test Model: MR33-HW

Received Date: Jul. 23, 2016

Test Date: Jul. 23 ~ Sep. 12, 2016

Issued Date: Sep. 13, 2016

Applicant: Cisco Systems, Inc.

Address: 170 West Tasman Drive, San Jose, CA 95134

Issued By: Bureau Veritas Consumer Products Services (H.K.) Ltd., Taoyuan Branch

Lab Address: No. 47-2, 14th Ling, Chia Pau Vil., Lin Kou Dist., New Taipei City, Taiwan, R.O.C.

Test Location: No.19, Hwa Ya 2nd Rd., Wen Hwa Vil., Kwei Shan Dist., Taoyuan City 33383, TAIWAN (R.O.C.)



This report is for your exclusive use. Any copying or replication of this report to or for any other person or entity, or use of our name or trademark, is permitted only with our prior written permission. This report sets forth our findings solely with respect to the test samples identified herein. The results set forth in this report are not indicative or representative of the quality or characteristics of the lot from which a test sample was taken or any similar or identical product unless specifically and expressly noted. Our report includes all of the tests requested by you and the results thereof based upon the information that you provided to us. You have 60 days from date of issuance of this report to notify us of any material error or omission caused by our negligence, provided, however, that such notice shall be in writing and shall specifically address the issue you wish to raise. A failure to raise such issue within the prescribed time shall constitute your unqualified acceptance of the completeness of this report, the tests conducted and the correctness of the report contents. Unless specific mention, the uncertainty of measurement has been explicitly taken into account to declare the compliance or non-compliance to the specification. This report should not be used by the client to claim product certification, approval, or endorsement by TAF or any government agencies.

Table of Contents

Release Control Record	4
1 Certificate of Conformity	5
2 Summary of Test Results	6
2.1 Measurement Uncertainty.....	6
2.2 Modification Record.....	6
3 General Information	7
3.1 General Description of EUT.....	7
3.2 Description of Test Modes.....	9
3.2.1 Test Mode Applicability and Tested Channel Detail.....	10
3.3 Duty Cycle of Test Signal.....	12
3.4 Description of Support Units.....	15
3.4.1 Configuration of System under Test.....	16
3.5 General Description of Applied Standards.....	17
4 Test Types and Results	18
4.1 Radiated Emission and Bandedge Measurement.....	18
4.1.1 Limits of Radiated Emission and Bandedge Measurement.....	18
4.1.2 Test Instruments.....	19
4.1.3 Test Procedures.....	20
4.1.4 Deviation from Test Standard.....	20
4.1.5 Test Set Up.....	21
4.1.6 EUT Operating Conditions.....	21
4.1.7 Test Results.....	22
4.2 Conducted Emission Measurement.....	56
4.2.1 Limits of Conducted Emission Measurement.....	56
4.2.2 Test Instruments.....	56
4.2.3 Test Procedures.....	57
4.2.4 Deviation from Test Standard.....	57
4.2.5 Test Setup.....	57
4.2.6 EUT Operating Conditions.....	57
4.2.7 Test Results.....	58
4.3 6dB Bandwidth Measurement.....	66
4.3.1 Limits of 6dB Bandwidth Measurement.....	66
4.3.2 Test Setup.....	66
4.3.3 Test Instruments.....	66
4.3.4 Test Procedure.....	66
4.3.5 Deviation from Test Standard.....	66
4.3.6 EUT Operating Conditions.....	66
4.3.7 Test Result.....	67
4.4 Conducted Output Power Measurement.....	72
4.4.1 Limits of Conducted Output Power Measurement.....	72
4.4.2 Test Setup.....	72
4.4.3 Test Instruments.....	72
4.4.4 Test Procedures.....	72
4.4.5 Deviation from Test Standard.....	72
4.4.6 EUT Operating Conditions.....	72
4.4.7 Test Results.....	73
4.5 Power Spectral Density Measurement.....	77
4.5.1 Limits of Power Spectral Density Measurement.....	77
4.5.2 Test Setup.....	77
4.5.3 Test Instruments.....	77
4.5.4 Test Procedure.....	77
4.5.5 Deviation from Test Standard.....	78
4.5.6 EUT Operating Condition.....	78

4.5.7 Test Results	79
4.6 Conducted Out of Band Emission Measurement.....	86
4.6.1 Limits of Conducted Out of Band Emission Measurement	86
4.6.2 Test Setup.....	86
4.6.3 Test Instruments	86
4.6.4 Test Procedure	86
4.6.5 Deviation from Test Standard	87
4.6.6 EUT Operating Condition	87
4.6.7 Test Results	87
5 Pictures of Test Arrangements.....	104
Appendix – Information on the Testing Laboratories	105

Release Control Record

Issue No.	Description	Date Issued
RF160725C02	Original release	Sep. 13, 2016

1 Certificate of Conformity

Product: Wireless 802.11 abgn/ac indoor AP

Brand: Cisco

Test Model: MR33-HW

Sample Status: Engineering sample

Applicant: Cisco Systems, Inc.

Test Date: Jul. 23 ~ Sep. 12, 2016

Standards: 47 CFR FCC Part 15, Subpart C (Section 15.247)
ANSI C63.10:2013

The above equipment has been tested by **Bureau Veritas Consumer Products Services (H.K.) Ltd., Taoyuan Branch**, and found compliance with the requirement of the above standards. The test record, data evaluation & Equipment Under Test (EUT) configurations represented herein are true and accurate accounts of the measurements of the sample's EMC characteristics under the conditions specified in this report.

Prepared by : Ivy Lin , **Date:** Sep. 13, 2016
Ivy Lin / Specialist

Approved by : Ken Liu , **Date:** Sep. 13, 2016
Ken Liu / Senior Manager

2 Summary of Test Results

47 CFR FCC Part 15, Subpart C (Section 15.247)			
FCC Clause	Test Item	Result	Remarks
15.207	AC Power Conducted Emission	Pass	Meet the requirement of limit. Minimum passing margin is -13.84dB at 0.15000MHz
15.205 / 15.209 / 15.247(d)	Radiated Emissions and Band Edge Measurement	Pass	Meet the requirement of limit. Minimum passing margin is -1.1dB at 2483.50MHz, 7311.00MHz.
15.247(d)	Antenna Port Emission	Pass	Meet the requirement of limit.
15.247(a)(2)	6dB bandwidth	Pass	Meet the requirement of limit.
15.247(b)	Conducted power	Pass	Meet the requirement of limit.
15.247(e)	Power Spectral Density	Pass	Meet the requirement of limit.
15.203	Antenna Requirement	Pass	Antenna connector is IPEX not a standard connector.

2.1 Measurement Uncertainty

Where relevant, the following measurement uncertainty levels have been estimated for tests performed on the EUT as specified in CISPR 16-4-2:

Measurement	Frequency	Expanded Uncertainty (k=2) (
-------------	-----------	------------------------------

3 General Information

3.1 General Description of EUT

Product	Wireless 802.11 abgn/ac indoor AP
Brand	Cisco
Test Model	MR33-HW
Sample Status	Engineering sample
Power Supply Rating	12Vdc from adapter 48Vdc or 55Vdc from POE
Modulation Type	CCK, DQPSK, DBPSK for DSSS 64QAM, 16QAM, QPSK, BPSK for OFDM
Modulation Technology	DSSS, OFDM
Transfer Rate	802.11b: 11.0/ 5.5/ 2.0/ 1.0Mbps 802.11g: 54.0/ 48.0/ 36.0/ 24.0/ 18.0/ 12.0/ 9.0/ 6.0Mbps 802.11n: up to 300Mbps
Operating Frequency	2412 ~ 2462MHz
Number of Channel	11 for 802.11b, 802.11g, 802.11n (HT20) 7 for 802.11n (HT40)
Output Power	Radio 1: CDD Mode: 184.727mW Beamforming Mode: 150.681mW Radio 3: CDD Mode: 157.761mW
Antenna Type	Refer to note
Antenna Connector	Refer to note
Accessory Device	NA
Data Cable Supplied	NA

Note:

- The EUT incorporates a MIMO function. Physically, the EUT provides 2 completed transmitters and 2 receivers.

Modulation Mode	TX Function	Beamforming	Remark
802.11b	2TX	Not Support	Radio 1
802.11g	2TX	Not Support	
802.11n (HT20)	2TX	Support	
802.11n (HT40)	2TX	Support	
802.11b	1TX	Not Support	Radio 3
802.11g	1TX	Not Support	
802.11n (HT20)	1TX	Not Support	
802.11n (HT40)	1TX	Not Support	

* For 2.4GHz band, CDD mode is the worst case for final radiated emission below 1GHz and power line conducted emission tests after pretesting CDD mode and beamforming mode.

2. The EUT with follow antennas gain is listed as table below.

No.	Type	Connector	Gain(dBi)		Remark
			2.4GHz	5GHz	
1	PIFA	IPEX	4.17	-	Radio 1 (WLAN)
2	PIFA	IPEX	3.74	-	
3	PIFA	IPEX	-	5.34	Radio 2 (WLAN)
4	PIFA	IPEX	-	5.71	
5	Printed	IPEX	5.67	-	Radio 4 (BT LE)
6	Printed	IPEX	4.65	5.50	Radio 3 (WLAN)

3. The EUT consumes power from the following adapter and POE. (Support unit only)

Adapter	
Brand	CISCO
Model	KSAS0361200250HU
Input Power	100-240Vac, 50/60Hz, 1.0A
Output Power	12Vdc/ 2.5A
Power Line	1.5m cable without one core attached on adapter

POE	
Brand	CISCO
Model	MA-INJ-4
Input Power	100-240Vac, 50/60Hz, 0.67A
Output Power	55Vdc/ 0.6A
Power Line	1.4m non-shielded Power cable without core

4. 2.4GHz, 5GHz and BT LE technology can transmit at same time.

5. Spurious emission of the simultaneous operation (2.4GHz, 5GHz and BT LE) has been evaluated and no non-compliance was found.

3.2 Description of Test Modes

11 channels are provided for 802.11b, 802.11g and 802.11n (HT20):

Channel	Frequency	Channel	Frequency
1	2412MHz	7	2442MHz
2	2417MHz	8	2447MHz
3	2422MHz	9	2452MHz
4	2427MHz	10	2457MHz
5	2432MHz	11	2462MHz
6	2437MHz		

7 channels are provided for 802.11n (HT40):

Channel	Frequency	Channel	Frequency
3	2422MHz	7	2442MHz
4	2427MHz	8	2447MHz
5	2432MHz	9	2452MHz
6	2437MHz		

3.2.1 Test Mode Applicability and Tested Channel Detail

EUT CONFIGURE MODE	APPLICABLE TO				DESCRIPTION
	RE \geq 1G	RE $<$ 1G	PLC	APCM	
A	√	√	√	√	Power from adapter
B	-	√	√	-	Power from POE

Where **RE \geq 1G**: Radiated Emission above 1GHz & Bandedge Measurement
RE $<$ 1G: Radiated Emission below 1GHz
PLC: Power Line Conducted Emission
APCM: Antenna Port Conducted Measurement

Note:

1. The EUT had been pre-tested on the positioned of each 3 axis. The worst case was found when positioned on **Z-plane**.
2. "-" means no effect.

Radiated Emission Test (Above 1GHz):

- Pre-Scan has been conducted to determine the worst-case mode from all possible combinations between available modulations, data rates and antenna ports (if EUT with antenna diversity architecture).
- Following channel(s) was (were) selected for the final test as listed below.

EUT CONFIGURE MODE	MODE	AVAILABLE CHANNEL	TESTED CHANNEL	MODULATION TECHNOLOGY	MODULATION TYPE	DATA RATE (Mbps)	REMARK
A	802.11b	1 to 11	1, 6, 11	DSSS	DBPSK	1.0	Radio 1 (2TX)
		1 to 11	1, 6, 11	DSSS	DBPSK	1.0	Radio 3 (1TX)
A	802.11g	1 to 11	1, 6, 11	OFDM	BPSK	6.0	Radio 1 (2TX)
		1 to 11	1, 6, 11	OFDM	BPSK	6.0	Radio 3 (1TX)
A	802.11n (HT20)	1 to 11	1, 6, 11	OFDM	BPSK	6.5	Radio 1 (2TX)
		1 to 11	1, 6, 11	OFDM	BPSK	6.5	Radio 3 (1TX)
A	802.11n (HT40)	3 to 9	3, 6, 9	OFDM	BPSK	13.5	Radio 1 (2TX)
		3 to 9	3, 6, 9	OFDM	BPSK	13.5	Radio 3 (1TX)

Radiated Emission Test (Below 1GHz):

- Pre-Scan has been conducted to determine the worst-case mode from all possible combinations between available modulations, data rates and antenna ports (if EUT with antenna diversity architecture).
- Following channel(s) was (were) selected for the final test as listed below.

EUT CONFIGURE MODE	MODE	AVAILABLE CHANNEL	TESTED CHANNEL	MODULATION TECHNOLOGY	MODULATION TYPE	DATA RATE (Mbps)	REMARK
A, B	802.11b	1 to 11	1	DSSS	DBPSK	1.0	Radio 1 (2TX)
		1 to 11	1	DSSS	DBPSK	1.0	Radio 3 (1TX)

Power Line Conducted Emission Test:

- Pre-Scan has been conducted to determine the worst-case mode from all possible combinations between available modulations, data rates and antenna ports (if EUT with antenna diversity architecture).
- Following channel(s) was (were) selected for the final test as listed below.

EUT CONFIGURE MODE	MODE	AVAILABLE CHANNEL	TESTED CHANNEL	MODULATION TECHNOLOGY	MODULATION TYPE	DATA RATE (Mbps)	REMARK
A, B	802.11b	1 to 11	1	DSSS	DBPSK	1.0	Radio 1 (2TX)
		1 to 11	1	DSSS	DBPSK	1.0	Radio 3 (1TX)

Antenna Port Conducted Measurement:

- This item includes all test value of each mode, but only includes spectrum plot of worst value of each mode.
- Pre-Scan has been conducted to determine the worst-case mode from all possible combinations between available modulations, data rates and antenna ports (if EUT with antenna diversity architecture).
- Following channel(s) was (were) selected for the final test as listed below.

EUT CONFIGURE MODE	MODE	AVAILABLE CHANNEL	TESTED CHANNEL	MODULATION TECHNOLOGY	MODULATION TYPE	DATA RATE (Mbps)	REMARK
A	802.11b	1 to 11	1, 6, 11	DSSS	DBPSK	1.0	Radio 1 (2TX)
		1 to 11	1, 6, 11	DSSS	DBPSK	1.0	Radio 3 (1TX)
A	802.11g	1 to 11	1, 6, 11	OFDM	BPSK	6.0	Radio 1 (2TX)
		1 to 11	1, 6, 11	OFDM	BPSK	6.0	Radio 3 (1TX)
A	802.11n (HT20)	1 to 11	1, 6, 11	OFDM	BPSK	6.5	Radio 1 (2TX)
		1 to 11	1, 6, 11	OFDM	BPSK	6.5	Radio 3 (1TX)
A	802.11n (HT40)	3 to 9	3, 6, 9	OFDM	BPSK	13.5	Radio 1 (2TX)
		3 to 9	3, 6, 9	OFDM	BPSK	13.5	Radio 3 (1TX)

Test Condition:

APPLICABLE TO	ENVIRONMENTAL CONDITIONS	INPUT POWER	TESTED BY
RE≥1G	16deg. C, 70%RH	120Vac/60Hz	James Yang, Jones Chang
RE<1G	16deg. C, 70%RH	120Vac/60Hz 55Vdc	James Yang
PLC	20deg. C, 70%RH	120Vac/60Hz 55Vdc	Jones Chang
APCM	25deg. C, 60%RH	120Vac/60Hz	Ted Chang, Frank Liu

3.3 Duty Cycle of Test Signal

Radio 1: CDD Mode

802.11b: Duty cycle of test signal is 100 %, duty factor is not required.

802.11n (HT20): Duty cycle of test signal is > 98%, duty factor is not required.

802.11g & 802.11n (HT40): Duty cycle of test signal is < 98%, duty factor shall be considered.

802.11b: Duty cycle of test signal is 100 %, duty factor is not required.

802.11g: Duty cycle = $2.063/2.150 = 0.960$, Duty factor = $10 * \log(1/0.960) = 0.18$

802.11n (HT20): Duty cycle = $4.994/5.094 = 0.980$

802.11n (HT40): Duty cycle = $2.420/2.522 = 0.960$, Duty factor = $10 * \log(1/0.960) = 0.18$

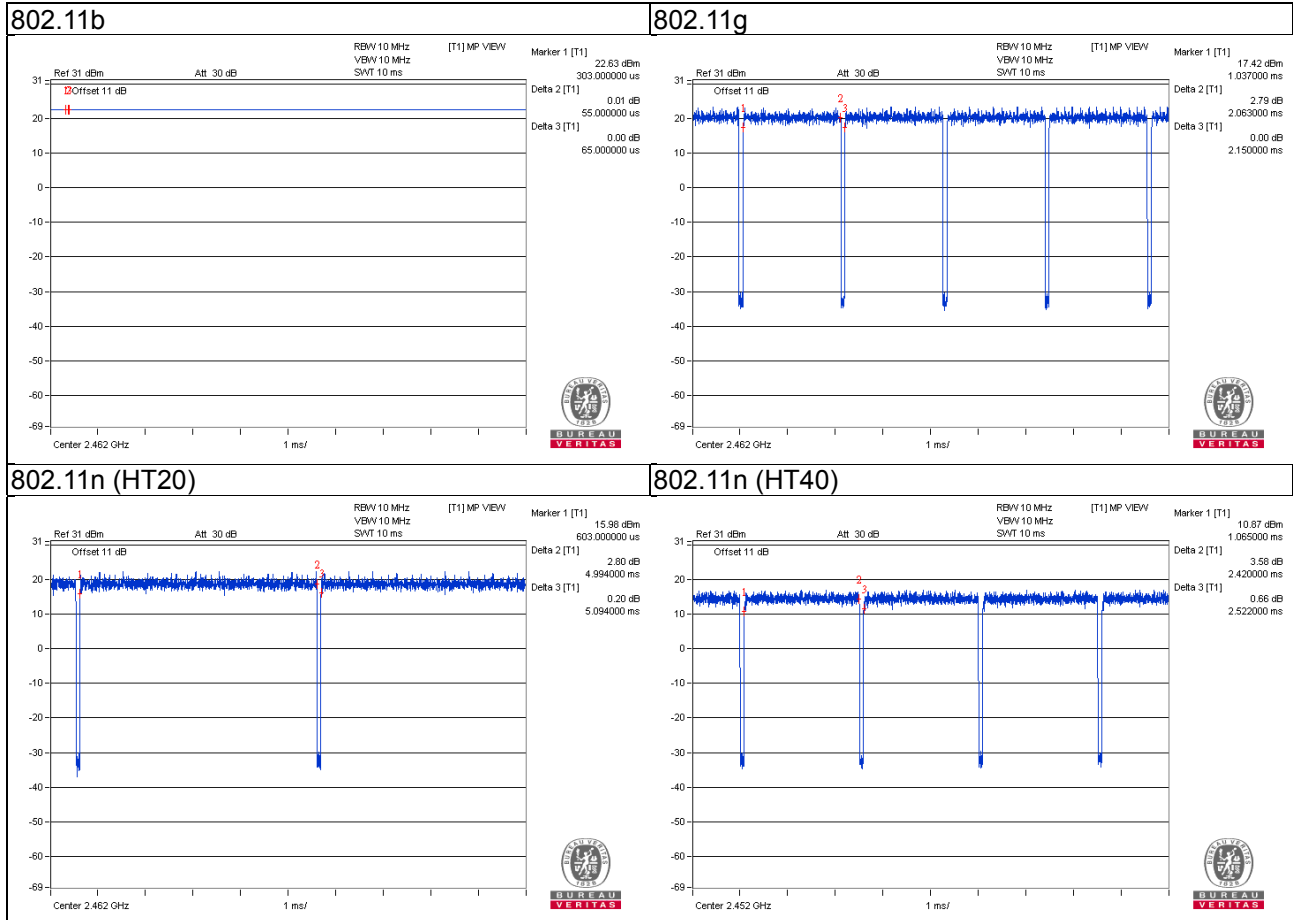

Radio 1: Beamforming Mode

Duty cycle of test signal is < 98%, duty factor shall be considered.

802.11n (HT20): Duty cycle = $4.981/5.090 = 0.979$, Duty factor = $10 * \log(1/0.979) = 0.09$

802.11n (HT40): Duty cycle = $2.402/2.502 = 0.960$, Duty factor = $10 * \log(1/0.960) = 0.18$

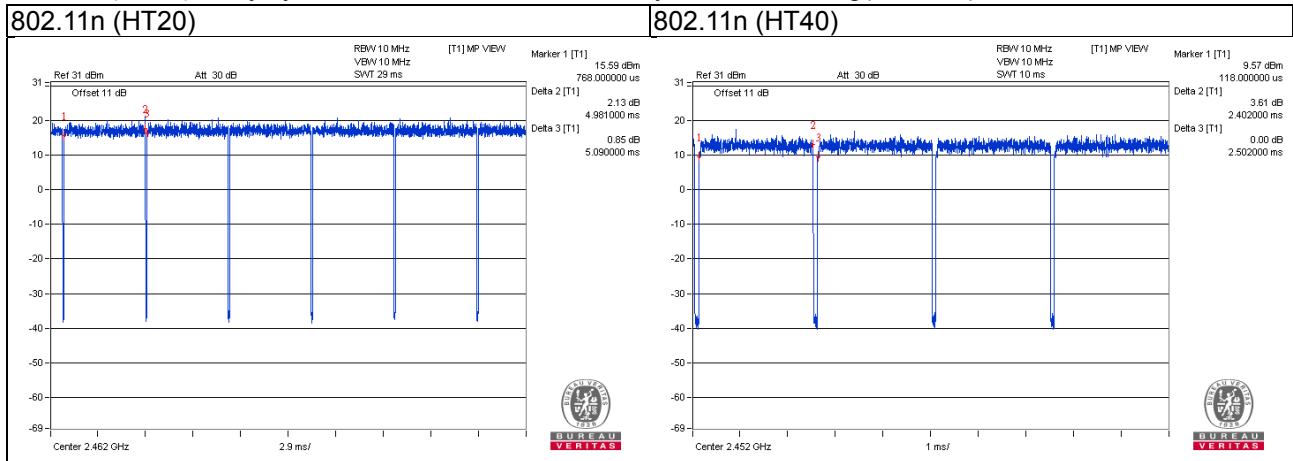

Radio 3: CDD Mode

802.11b: Duty cycle = $0.055/0.065 = 0.846$, Duty factor = $10 * \log(1/0.846) = 0.73$

802.11g: Duty cycle = $1.914/2.022 = 0.947$, Duty factor = $10 * \log(1/0.947) = 0.24$

802.11n (HT20): Duty cycle = $1.920/2.025 = 0.948$, Duty factor = $10 * \log(1/0.948) = 0.23$

802.11n (HT40): Duty cycle = $0.940/1.040 = 0.904$, Duty factor = $10 * \log(1/0.904) = 0.44$

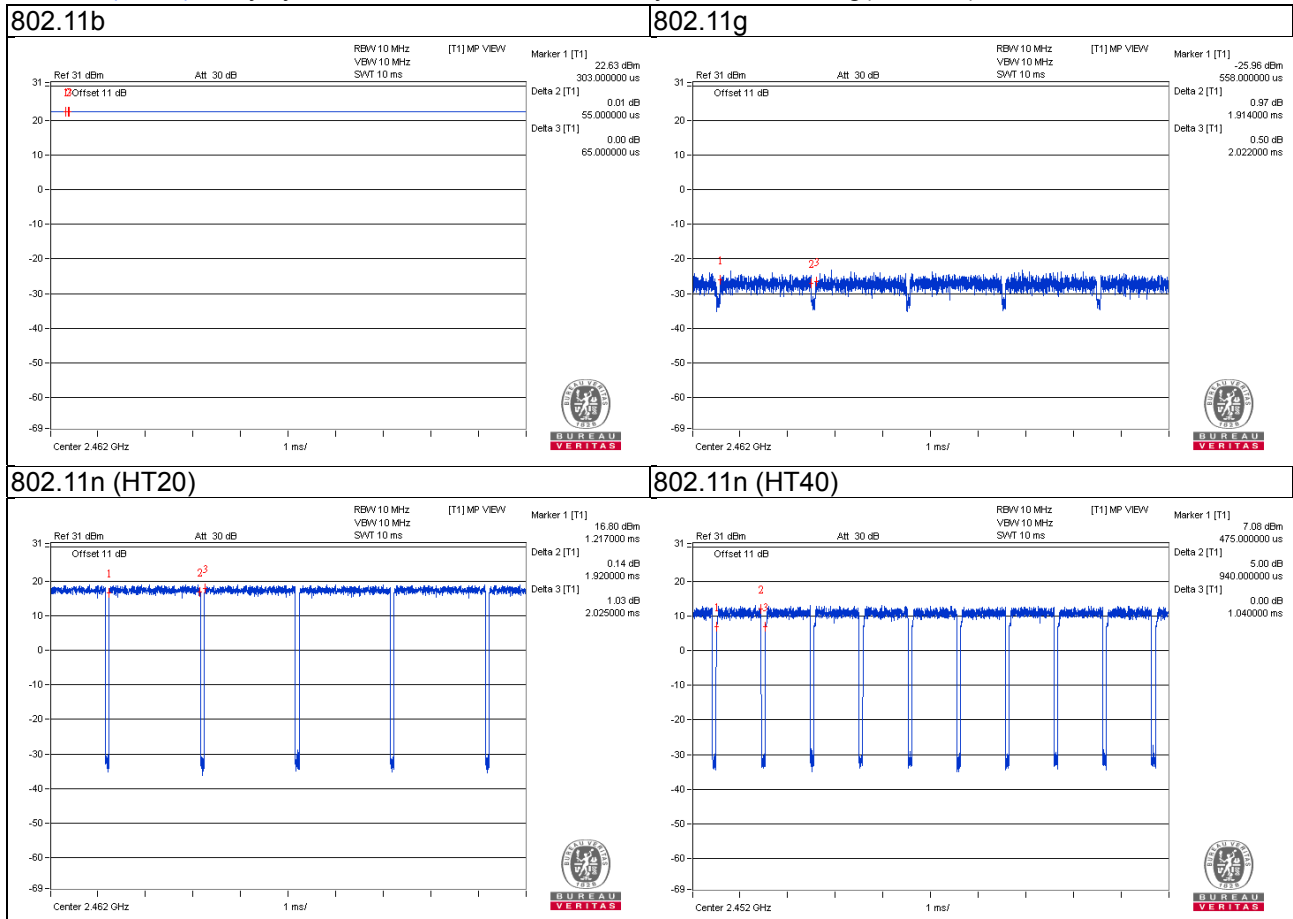

3.4 Description of Support Units

The EUT has been tested as an independent unit together with other necessary accessories or support units. The following support units or accessories were used to form a representative test configuration during the tests.

ID	Product	Brand	Model No.	Serial No.	FCC ID	Remarks
A.	Notebook	DELL	E5410	6RP2YM1	FCC DoC Approved	-
B.	Adapter	CISCO	KSAS0361200250HU	N/A	N/A	Provided by manufacturer For test mode A only
C.	POE	CISCO	MA-INJ-4	N/A	N/A	Provided by manufacturer For test mode B only

Note:

1. All power cords of the above support units are non-shielded (1.8m).
2. Item A acted as communication partner to transfer data.

ID	Descriptions	Qty.	Length (m)	Shielding (Yes/No)	Cores (Qty.)	Remarks
1.	RJ45 Cable	1	3	N	0	Cat5e
2.	Power Cable	1	1.5	N	0	For test mode A only
3.	RJ45 Cable	1	1.8	N	0	Cat5e For test mode B only

3.4.1 Configuration of System under Test

Test Mode A

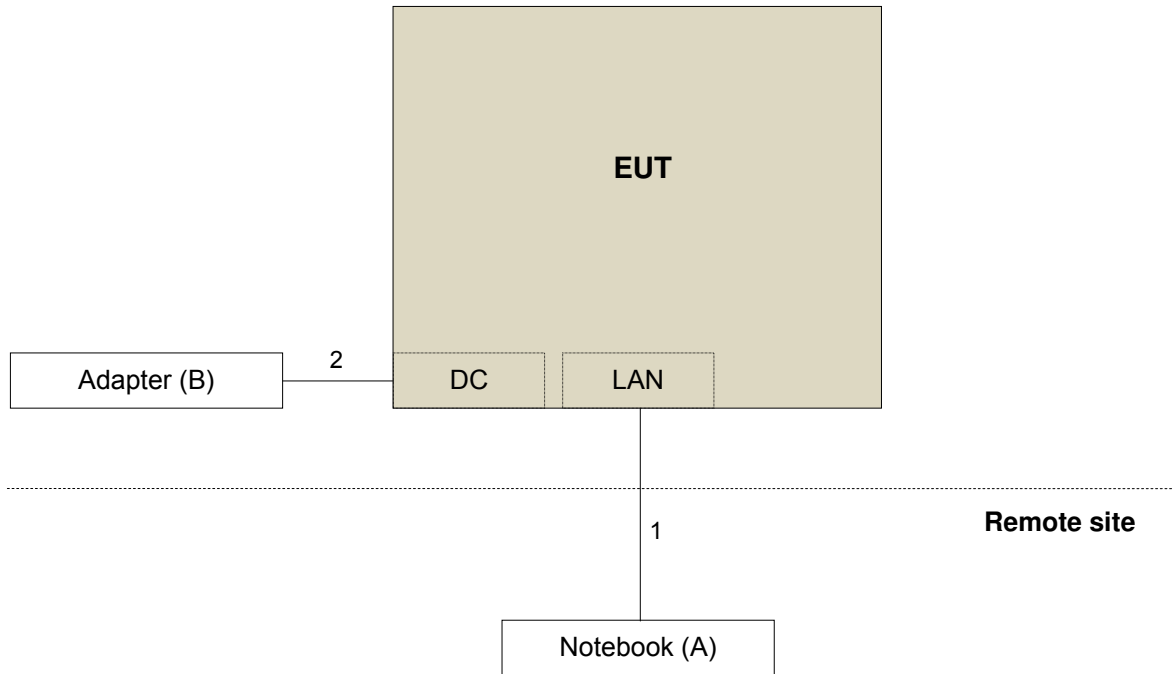

Test Mode B

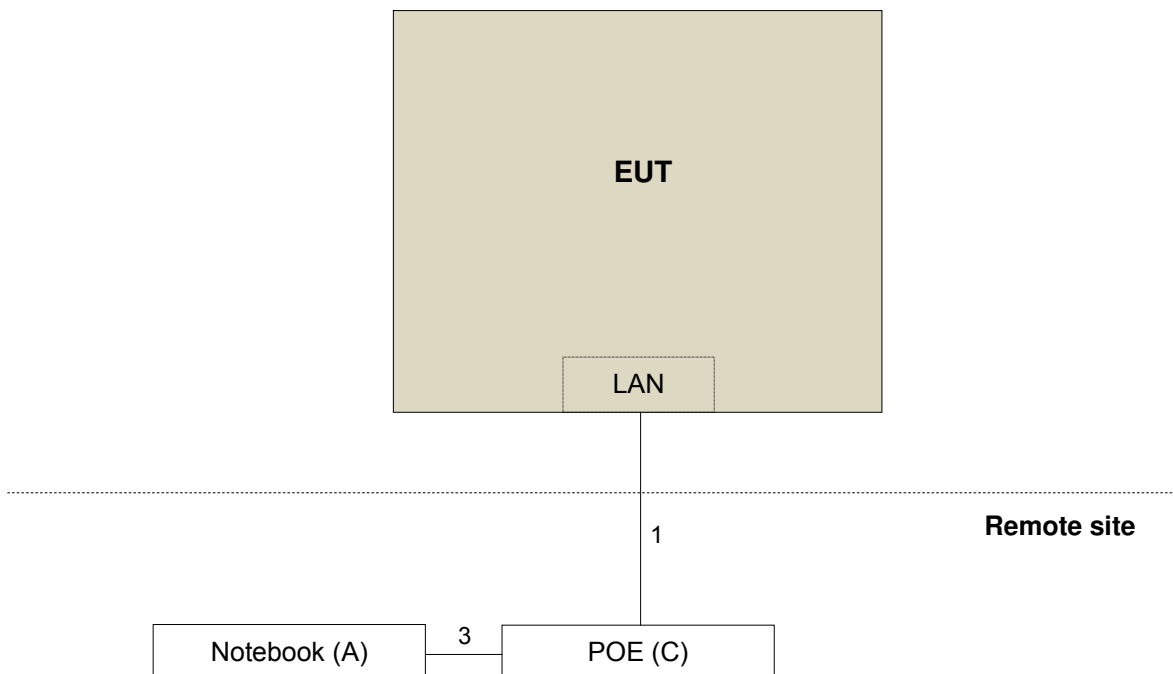

3.5 General Description of Applied Standards

The EUT is a RF Product. According to the specifications of the manufacturer, it must comply with the requirements of the following standards:

FCC Part 15, Subpart C (15.247)

KDB 558074 D01 DTS Meas Guidance v03r05

KDB 662911 D01 Multiple Transmitter Output v02r01

ANSI C63.10-2013

All test items have been performed and recorded as per the above standards.

Note: The EUT is also considered as a kind of computer peripheral, because the connection to computer is necessary for typical use. It has been verified to comply with the requirements of FCC Part 15, Subpart B, Class B (DoC). The test report has been issued separately.

4 Test Types and Results

4.1 Radiated Emission and Bandedge Measurement

4.1.1 Limits of Radiated Emission and Bandedge Measurement

Radiated emissions which fall in the restricted bands must comply with the radiated emission limits specified as below table. Other emissions shall be at least 20dB / 30dB below the highest level of the desired power:

Frequencies (MHz)	Field Strength (microvolts/meter)	Measurement Distance (meters)
0.009 ~ 0.490	2400/F(kHz)	300
0.490 ~ 1.705	24000/F(kHz)	30
1.705 ~ 30.0	30	30
30 ~ 88	100	3
88 ~ 216	150	3
216 ~ 960	200	3
Above 960	500	3

Note:

1. The lower limit shall apply at the transition frequencies.
2. Emission level (dBuV/m) = 20 log Emission level (uV/m).
3. For frequencies above 1000MHz, the field strength limits are based on average detector, however, the peak field strength of any emission shall not exceed the maximum permitted average limits, specified above by more than 20dB / 30dB under any condition of modulation.

4.1.2 Test Instruments

Description & Manufacturer	Model No.	Serial No.	Cal. Date	Cal. Due
Test Receiver ROHDE & SCHWARZ	ESIB7	100187	Apr. 18, 2016	Apr. 17, 2017
Spectrum Analyzer ROHDE & SCHWARZ	FSP40	100039	May 03, 2016	May 02, 2017
BILOG Antenna SCHWARZBECK	VULB9168	9168-171	Jan. 07, 2016	Jan. 06, 2017
HORN Antenna SCHWARZBECK	9120D	209	Jan. 20, 2016	Jan. 19, 2017
HORN Antenna SCHWARZBECK	BBHA 9170	BBHA9170241	Jan. 18, 2016	Jan. 17, 2017
Preamplifier Agilent	8447D	2944A10738	Oct.18, 2015	Oct. 17, 2016
Preamplifier Agilent	8449B	3008A01964	Aug. 22, 2015	Aug. 21, 2016
			Aug. 22, 2016	Aug. 21, 2017
RF signal cable HUBER+SUHNER	SUCOFLEX 104	Cable-CH3-03 (214378)	Aug. 22, 2015	Aug. 21, 2016
			Aug. 22, 2016	Aug. 21, 2017
RF signal cable HUBER+SUHNER	SUCOFLEX 106	Cable-CH3-03 (309224+12738)	Aug. 22, 2015	Aug. 21, 2016
			Aug. 22, 2016	Aug. 21, 2017
Software BV ADT	ADT_Radiated_ V7.6.15.9.4	NA	NA	NA
Antenna Tower inn-co GmbH	MA 4000	013303	NA	NA
Antenna Tower Controller BV ADT	AT100	AT93021702	NA	NA
Turn Table BV ADT	TT100	TT93021702	NA	NA
Turn Table Controller BV ADT	SC100	SC93021702	NA	NA
High Speed Peak Power Meter	ML2495A	0824011	Jul. 09, 2015	Jul. 08, 2016
			Jul. 09, 2016	Jul. 08, 2017
Power Sensor	MA2411B	0738171	Jul. 09, 2015	Jul. 08, 2016
			Jul. 09, 2016	Jul. 08, 2017

- Note: 1. The calibration interval of the above test instruments is 12 months and the calibrations are traceable to NML/ROC and NIST/USA.
2. The test was performed in HwaYa Chamber 3.
3. The horn antenna and preamplifier (model: 8449B) are used only for the measurement of emission frequency above 1GHz if tested.
4. The FCC Site Registration No. is 988962.
5. The IC Site Registration No. is IC 7450F-3.

4.1.3 Test Procedures

- a. The EUT was placed on the top of a rotating table 0.8 meters (for below 1GHz) / 1.5 meters (for above 1GHz) above the ground at 3 meter chamber room for test. The table was rotated 360 degrees to determine the position of the highest radiation.
- b. The EUT was set 3 meters away from the interference-receiving antenna, which was mounted on the top of a variable-height antenna tower.
- c. The height of antenna is varied from one meter to four meters above the ground to determine the maximum value of the field strength. Both horizontal and vertical polarizations of the antenna are set to make the measurement.
- d. For each suspected emission, the EUT was arranged to its worst case and then the antenna was tuned to heights from 1 meter to 4 meters and the rotatable table was turned from 0 degrees to 360 degrees to find the maximum reading.
- e. The test-receiver system was set to quasi-peak detect function and specified bandwidth with maximum hold mode when the test frequency is below 1 GHz.
- f. The test-receiver system was set to peak and average detect function and specified bandwidth with maximum hold mode when the test frequency is above 1 GHz. If the peak reading value also meets average limit, measurement with the average detector is unnecessary.

Note:

1. The resolution bandwidth and video bandwidth of test receiver/spectrum analyzer is 120kHz for Quasi-peak detection (QP) at frequency below 1GHz.
2. The resolution bandwidth of test receiver/spectrum analyzer is 1 MHz and the video bandwidth is 3 MHz for Peak detection (PK) at frequency above 1GHz.
3. The resolution bandwidth of test receiver/spectrum analyzer is 1MHz and the video bandwidth is 3MHz for RMS Average (Duty cycle < 98%) for Average detection (AV) at frequency above 1GHz, then the measurement results was added to a correction factor ($10 \log(1/\text{duty cycle})$).
4. The resolution bandwidth of test receiver/spectrum analyzer is 1MHz and the video bandwidth is 10Hz (Duty cycle $\geq 98\%$) for Average detection (AV) at frequency above 1GHz.
5. All modes of operation were investigated and the worst-case emissions are reported.

4.1.4 Deviation from Test Standard

No deviation.

4.1.5 Test Set Up

<Frequency Range below 1GHz>

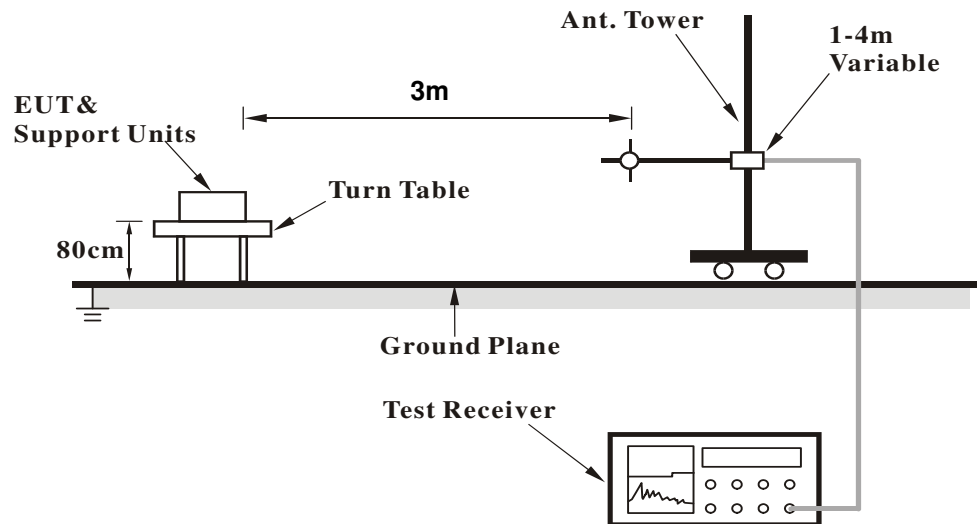

<Frequency Range above 1GHz>

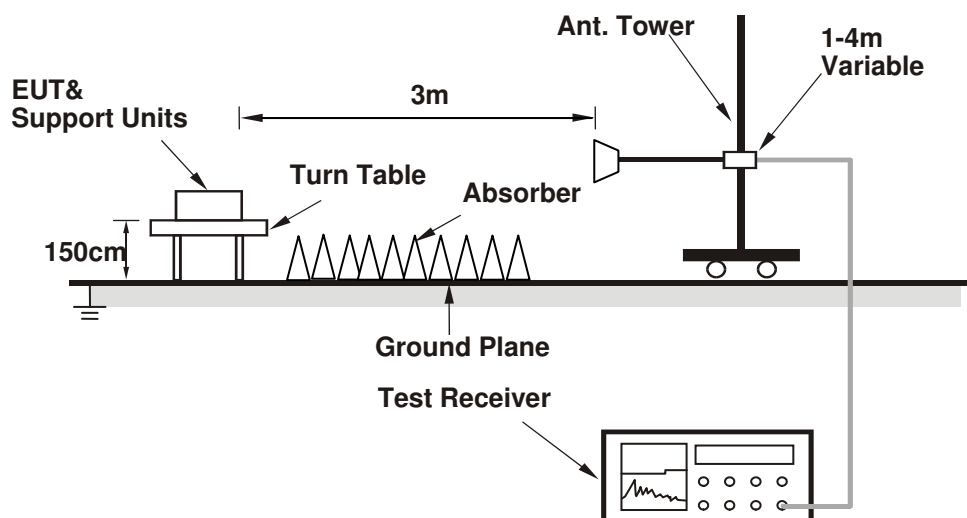

For the actual test configuration, please refer to the attached file (Test Setup Photo).

4.1.6 EUT Operating Conditions

- Placed the EUT on the testing table.
- Prepared a notebook to act as a communication partner and placed it outside of testing area.
- The communication partner connected with EUT via a RJ45 cable and ran a test program (provided by manufacturer) to enable EUT under transmission condition continuously at specific channel frequency.
- The communication partner sent data to EUT by command "PING".

4.1.7 Test Results

Above 1GHz worst-Case data:

Radio 1: CDD Mode

802.11b

CHANNEL	TX Channel 1	DETECTOR FUNCTION	Peak (PK)
FREQUENCY RANGE	1GHz ~ 25GHz		Average (AV)

ANTENNA POLARITY & TEST DISTANCE: HORIZONTAL AT 3 M								
NO.	FREQ. (MHz)	EMISSION LEVEL (dBuV/m)	LIMIT (dBuV/m)	MARGIN (dB)	ANTENNA HEIGHT (m)	TABLE ANGLE (Degree)	RAW VALUE (dBuV)	CORRECTION FACTOR (dB/m)
1	2390.00	58.5 PK	74.0	-15.5	2.63 H	34	25.70	32.80
2	2390.00	49.4 AV	54.0	-4.6	2.63 H	34	16.60	32.80
3	*2412.00	114.8 PK			2.57 H	43	81.90	32.90
4	*2412.00	112.0 AV			2.57 H	43	79.10	32.90
5	4824.00	51.8 PK	74.0	-22.2	2.40 H	356	45.90	5.90
6	4824.00	47.6 AV	54.0	-6.4	2.40 H	356	41.70	5.90

ANTENNA POLARITY & TEST DISTANCE: VERTICAL AT 3 M								
NO.	FREQ. (MHz)	EMISSION LEVEL (dBuV/m)	LIMIT (dBuV/m)	MARGIN (dB)	ANTENNA HEIGHT (m)	TABLE ANGLE (Degree)	RAW VALUE (dBuV)	CORRECTION FACTOR (dB/m)
1	2390.00	56.7 PK	74.0	-17.3	1.73 V	15	23.90	32.80
2	2390.00	45.4 AV	54.0	-8.6	1.73 V	15	12.60	32.80
3	*2412.00	104.4 PK			1.76 V	213	71.50	32.90
4	*2412.00	100.6 AV			1.76 V	213	67.70	32.90
5	4824.00	50.4 PK	74.0	-23.6	1.70 V	183	44.50	5.90
6	4824.00	44.7 AV	54.0	-9.3	1.70 V	183	38.80	5.90

REMARKS:

1. Emission Level(dBuV/m) = Raw Value(dBuV) + Correction Factor(dB/m)
2. Correction Factor(dB/m) = Antenna Factor(dB/m) + Cable Factor(dB)
3. The other emission levels were very low against the limit.
4. Margin value = Emission Level – Limit value
5. " * ": Fundamental frequency.

CHANNEL	TX Channel 6	DETECTOR FUNCTION	Peak (PK)
FREQUENCY RANGE	1GHz ~ 25GHz		Average (AV)

ANTENNA POLARITY & TEST DISTANCE: HORIZONTAL AT 3 M

NO.	FREQ. (MHz)	EMISSION LEVEL (dBuV/m)	LIMIT (dBuV/m)	MARGIN (dB)	ANTENNA HEIGHT (m)	TABLE ANGLE (Degree)	RAW VALUE (dBuV)	CORRECTION FACTOR (dB/m)
1	*2437.00	114.4 PK			2.89 H	34	81.50	32.90
2	*2437.00	111.6 AV			2.89 H	34	78.70	32.90
3	4874.00	49.4 PK	74.0	-24.6	1.18 H	201	43.40	6.00
4	4874.00	41.6 AV	54.0	-12.4	1.18 H	201	35.60	6.00

ANTENNA POLARITY & TEST DISTANCE: VERTICAL AT 3 M

NO.	FREQ. (MHz)	EMISSION LEVEL (dBuV/m)	LIMIT (dBuV/m)	MARGIN (dB)	ANTENNA HEIGHT (m)	TABLE ANGLE (Degree)	RAW VALUE (dBuV)	CORRECTION FACTOR (dB/m)
1	*2437.00	106.0 PK			2.45 V	36	73.10	32.90
2	*2437.00	103.7 AV			2.45 V	36	70.80	32.90
3	4874.00	50.3 PK	74.0	-23.7	2.45 V	157	44.30	6.00
4	4874.00	43.5 AV	54.0	-10.5	2.45 V	157	37.50	6.00

REMARKS:

1. Emission Level(dBuV/m) = Raw Value(dBuV) + Correction Factor(dB/m)
2. Correction Factor(dB/m) = Antenna Factor(dB/m) + Cable Factor(dB)
3. The other emission levels were very low against the limit.
4. Margin value = Emission Level – Limit value
5. " * " : Fundamental frequency.

CHANNEL	TX Channel 11	DETECTOR FUNCTION	Peak (PK)
FREQUENCY RANGE	1GHz ~ 25GHz		Average (AV)

ANTENNA POLARITY & TEST DISTANCE: HORIZONTAL AT 3 M

NO.	FREQ. (MHz)	EMISSION LEVEL (dBuV/m)	LIMIT (dBuV/m)	MARGIN (dB)	ANTENNA HEIGHT (m)	TABLE ANGLE (Degree)	RAW VALUE (dBuV)	CORRECTION FACTOR (dB/m)
1	*2462.00	115.5 PK			1.04 H	310	82.60	32.90
2	*2462.00	113.3 AV			1.04 H	310	80.40	32.90
3	2483.50	58.1 PK	74.0	-15.9	1.84 H	326	25.10	33.00
4	2483.50	47.2 AV	54.0	-6.8	1.84 H	326	14.20	33.00
5	4924.00	51.0 PK	74.0	-23.0	2.84 H	324	45.00	6.00
6	4924.00	44.2 AV	54.0	-9.8	2.84 H	324	38.20	6.00

ANTENNA POLARITY & TEST DISTANCE: VERTICAL AT 3 M

NO.	FREQ. (MHz)	EMISSION LEVEL (dBuV/m)	LIMIT (dBuV/m)	MARGIN (dB)	ANTENNA HEIGHT (m)	TABLE ANGLE (Degree)	RAW VALUE (dBuV)	CORRECTION FACTOR (dB/m)
1	*2462.00	110.6 PK			2.46 V	346	77.70	32.90
2	*2462.00	106.7 AV			2.46 V	346	73.80	32.90
3	2483.50	56.6 PK	74.0	-17.4	2.53 V	274	23.60	33.00
4	2483.50	45.5 AV	54.0	-8.5	2.53 V	274	12.50	33.00
5	4924.00	51.8 PK	74.0	-22.2	3.34 V	351	45.80	6.00
6	4924.00	45.0 AV	54.0	-9.0	3.34 V	351	39.00	6.00

REMARKS:

1. Emission Level(dBuV/m) = Raw Value(dBuV) + Correction Factor(dB/m)
2. Correction Factor(dB/m) = Antenna Factor(dB/m) + Cable Factor(dB)
3. The other emission levels were very low against the limit.
4. Margin value = Emission Level – Limit value
5. " * " : Fundamental frequency.

802.11g

CHANNEL	TX Channel 1	DETECTOR FUNCTION	Peak (PK)
FREQUENCY RANGE	1GHz ~ 25GHz		Average (AV)

ANTENNA POLARITY & TEST DISTANCE: HORIZONTAL AT 3 M								
NO.	FREQ. (MHz)	EMISSION LEVEL (dBuV/m)	LIMIT (dBuV/m)	MARGIN (dB)	ANTENNA HEIGHT (m)	TABLE ANGLE (Degree)	RAW VALUE (dBuV)	CORRECTION FACTOR (dB/m)
1	2390.00	67.7 PK	74.0	-6.3	2.32 H	329	34.90	32.80
2	2390.00	52.8 AV	54.0	-1.2	2.32 H	329	20.00	32.80
3	*2412.00	111.8 PK			2.59 H	34	78.90	32.90
4	*2412.00	101.4 AV			2.59 H	34	68.50	32.90
5	4824.00	46.6 PK	74.0	-27.4	3.15 H	222	40.70	5.90
6	4824.00	34.6 AV	54.0	-19.4	3.15 H	222	28.70	5.90
ANTENNA POLARITY & TEST DISTANCE: VERTICAL AT 3 M								
NO.	FREQ. (MHz)	EMISSION LEVEL (dBuV/m)	LIMIT (dBuV/m)	MARGIN (dB)	ANTENNA HEIGHT (m)	TABLE ANGLE (Degree)	RAW VALUE (dBuV)	CORRECTION FACTOR (dB/m)
1	2390.00	63.7 PK	74.0	-10.3	3.47 V	346	30.90	32.80
2	2390.00	49.5 AV	54.0	-4.5	3.47 V	346	16.70	32.80
3	*2412.00	109.4 PK			3.35 V	341	76.50	32.90
4	*2412.00	99.2 AV			3.35 V	341	66.30	32.90
5	4824.00	48.3 PK	74.0	-25.7	1.22 V	168	42.40	5.90
6	4824.00	39.9 AV	54.0	-14.1	1.22 V	168	34.00	5.90

REMARKS:

1. Emission Level(dBuV/m) = Raw Value(dBuV) + Correction Factor(dB/m)
2. Correction Factor(dB/m) = Antenna Factor(dB/m) + Cable Factor(dB)
3. The other emission levels were very low against the limit.
4. Margin value = Emission Level – Limit value
5. " * " : Fundamental frequency.

CHANNEL	TX Channel 6	DETECTOR FUNCTION	Peak (PK)
FREQUENCY RANGE	1GHz ~ 25GHz		Average (AV)

ANTENNA POLARITY & TEST DISTANCE: HORIZONTAL AT 3 M

NO.	FREQ. (MHz)	EMISSION LEVEL (dBuV/m)	LIMIT (dBuV/m)	MARGIN (dB)	ANTENNA HEIGHT (m)	TABLE ANGLE (Degree)	RAW VALUE (dBuV)	CORRECTION FACTOR (dB/m)
1	*2437.00	114.2 PK			1.47 H	324	81.30	32.90
2	*2437.00	104.2 AV			1.47 H	324	71.30	32.90
3	4874.00	47.1 PK	74.0	-26.9	1.75 H	163	41.10	6.00
4	4874.00	34.1 AV	54.0	-19.9	1.75 H	163	28.10	6.00

ANTENNA POLARITY & TEST DISTANCE: VERTICAL AT 3 M

NO.	FREQ. (MHz)	EMISSION LEVEL (dBuV/m)	LIMIT (dBuV/m)	MARGIN (dB)	ANTENNA HEIGHT (m)	TABLE ANGLE (Degree)	RAW VALUE (dBuV)	CORRECTION FACTOR (dB/m)
1	*2437.00	111.0 PK			2.91 V	333	78.10	32.90
2	*2437.00	100.4 AV			2.91 V	333	67.50	32.90
3	4874.00	49.2 PK	74.0	-24.8	2.59 V	162	43.20	6.00
4	4874.00	39.4 AV	54.0	-14.6	2.59 V	162	33.40	6.00

REMARKS:

1. Emission Level(dBuV/m) = Raw Value(dBuV) + Correction Factor(dB/m)
2. Correction Factor(dB/m) = Antenna Factor(dB/m) + Cable Factor(dB)
3. The other emission levels were very low against the limit.
4. Margin value = Emission Level – Limit value
5. " * " : Fundamental frequency.

CHANNEL	TX Channel 11	DETECTOR FUNCTION	Peak (PK)
FREQUENCY RANGE	1GHz ~ 25GHz		Average (AV)

ANTENNA POLARITY & TEST DISTANCE: HORIZONTAL AT 3 M

NO.	FREQ. (MHz)	EMISSION LEVEL (dBuV/m)	LIMIT (dBuV/m)	MARGIN (dB)	ANTENNA HEIGHT (m)	TABLE ANGLE (Degree)	RAW VALUE (dBuV)	CORRECTION FACTOR (dB/m)
1	*2462.00	112.2 PK			1.44 H	322	79.30	32.90
2	*2462.00	102.0 AV			1.44 H	322	69.10	32.90
3	2483.50	68.7 PK	74.0	-5.3	1.20 H	305	35.70	33.00
4	2483.50	52.9 AV	54.0	-1.1	1.20 H	305	19.90	33.00
5	4924.00	47.1 PK	74.0	-26.9	1.74 H	234	41.10	6.00
6	4924.00	34.8 AV	54.0	-19.2	1.74 H	234	28.80	6.00

ANTENNA POLARITY & TEST DISTANCE: VERTICAL AT 3 M

NO.	FREQ. (MHz)	EMISSION LEVEL (dBuV/m)	LIMIT (dBuV/m)	MARGIN (dB)	ANTENNA HEIGHT (m)	TABLE ANGLE (Degree)	RAW VALUE (dBuV)	CORRECTION FACTOR (dB/m)
1	*2462.00	107.5 PK			2.87 V	11	74.60	32.90
2	*2462.00	97.7 AV			2.87 V	11	64.80	32.90
3	2483.50	64.3 PK	74.0	-9.7	2.91 V	324	31.30	33.00
4	2483.50	49.1 AV	54.0	-4.9	2.91 V	324	16.10	33.00
5	4924.00	49.1 PK	74.0	-24.9	2.83 V	164	43.10	6.00
6	4924.00	39.2 AV	54.0	-14.8	2.83 V	164	33.20	6.00

REMARKS:

1. Emission Level(dBuV/m) = Raw Value(dBuV) + Correction Factor(dB/m)
2. Correction Factor(dB/m) = Antenna Factor(dB/m) + Cable Factor(dB)
3. The other emission levels were very low against the limit.
4. Margin value = Emission Level – Limit value
5. " * " : Fundamental frequency.

802.11n (HT20)

CHANNEL	TX Channel 1	DETECTOR FUNCTION	Peak (PK)
FREQUENCY RANGE	1GHz ~ 25GHz		Average (AV)

ANTENNA POLARITY & TEST DISTANCE: HORIZONTAL AT 3 M

NO.	FREQ. (MHz)	EMISSION LEVEL (dBuV/m)	LIMIT (dBuV/m)	MARGIN (dB)	ANTENNA HEIGHT (m)	TABLE ANGLE (Degree)	RAW VALUE (dBuV)	CORRECTION FACTOR (dB/m)
1	2390.00	67.6 PK	74.0	-6.4	1.64 H	327	34.80	32.80
2	2390.00	52.6 AV	54.0	-1.4	1.64 H	327	19.80	32.80
3	*2412.00	109.2 PK			1.17 H	331	76.30	32.90
4	*2412.00	98.9 AV			1.17 H	331	66.00	32.90
5	4824.00	46.7 PK	74.0	-27.3	2.02 H	167	40.80	5.90
6	4824.00	34.0 AV	54.0	-20.0	2.02 H	167	28.10	5.90

ANTENNA POLARITY & TEST DISTANCE: VERTICAL AT 3 M

NO.	FREQ. (MHz)	EMISSION LEVEL (dBuV/m)	LIMIT (dBuV/m)	MARGIN (dB)	ANTENNA HEIGHT (m)	TABLE ANGLE (Degree)	RAW VALUE (dBuV)	CORRECTION FACTOR (dB/m)
1	2390.00	64.5 PK	74.0	-9.5	3.01 V	349	31.70	32.80
2	2390.00	48.9 AV	54.0	-5.1	3.01 V	349	16.10	32.80
3	*2412.00	106.7 PK			3.35 V	343	73.80	32.90
4	*2412.00	96.4 AV			3.35 V	343	63.50	32.90
5	4824.00	48.7 PK	74.0	-25.3	1.17 V	159	42.80	5.90
6	4824.00	37.4 AV	54.0	-16.6	1.17 V	159	31.50	5.90

REMARKS:

1. Emission Level(dBuV/m) = Raw Value(dBuV) + Correction Factor(dB/m)
2. Correction Factor(dB/m) = Antenna Factor(dB/m) + Cable Factor(dB)
3. The other emission levels were very low against the limit.
4. Margin value = Emission Level – Limit value
5. " * " : Fundamental frequency.

CHANNEL	TX Channel 6	DETECTOR FUNCTION	Peak (PK)
FREQUENCY RANGE	1GHz ~ 25GHz		Average (AV)

ANTENNA POLARITY & TEST DISTANCE: HORIZONTAL AT 3 M

NO.	FREQ. (MHz)	EMISSION LEVEL (dBuV/m)	LIMIT (dBuV/m)	MARGIN (dB)	ANTENNA HEIGHT (m)	TABLE ANGLE (Degree)	RAW VALUE (dBuV)	CORRECTION FACTOR (dB/m)
1	*2437.00	115.9 PK			1.34 H	318	83.00	32.90
2	*2437.00	105.8 AV			1.34 H	318	72.90	32.90
3	4874.00	46.8 PK	74.0	-27.2	1.40 H	227	40.80	6.00
4	4874.00	34.3 AV	54.0	-19.7	1.40 H	227	28.30	6.00

ANTENNA POLARITY & TEST DISTANCE: VERTICAL AT 3 M

NO.	FREQ. (MHz)	EMISSION LEVEL (dBuV/m)	LIMIT (dBuV/m)	MARGIN (dB)	ANTENNA HEIGHT (m)	TABLE ANGLE (Degree)	RAW VALUE (dBuV)	CORRECTION FACTOR (dB/m)
1	*2437.00	110.8 PK			2.98 V	346	77.90	32.90
2	*2437.00	100.7 AV			2.98 V	346	67.80	32.90
3	4874.00	49.2 PK	74.0	-24.8	1.09 V	176	43.20	6.00
4	4874.00	39.8 AV	54.0	-14.2	1.09 V	176	33.80	6.00

REMARKS:

1. Emission Level(dBuV/m) = Raw Value(dBuV) + Correction Factor(dB/m)
2. Correction Factor(dB/m) = Antenna Factor(dB/m) + Cable Factor(dB)
3. The other emission levels were very low against the limit.
4. Margin value = Emission Level – Limit value
5. " * " : Fundamental frequency.

CHANNEL	TX Channel 11	DETECTOR FUNCTION	Peak (PK)
FREQUENCY RANGE	1GHz ~ 25GHz		Average (AV)

ANTENNA POLARITY & TEST DISTANCE: HORIZONTAL AT 3 M

NO.	FREQ. (MHz)	EMISSION LEVEL (dBuV/m)	LIMIT (dBuV/m)	MARGIN (dB)	ANTENNA HEIGHT (m)	TABLE ANGLE (Degree)	RAW VALUE (dBuV)	CORRECTION FACTOR (dB/m)
1	*2462.00	111.5 PK			1.43 H	325	78.60	32.90
2	*2462.00	100.7 AV			1.43 H	325	67.80	32.90
3	2483.50	67.7 PK	74.0	-6.3	1.17 H	314	34.70	33.00
4	2483.50	52.7 AV	54.0	-1.3	1.17 H	314	19.70	33.00
5	4924.00	47.8 PK	74.0	-26.2	1.67 H	221	41.80	6.00
6	4924.00	34.5 AV	54.0	-19.5	1.67 H	221	28.50	6.00

ANTENNA POLARITY & TEST DISTANCE: VERTICAL AT 3 M

NO.	FREQ. (MHz)	EMISSION LEVEL (dBuV/m)	LIMIT (dBuV/m)	MARGIN (dB)	ANTENNA HEIGHT (m)	TABLE ANGLE (Degree)	RAW VALUE (dBuV)	CORRECTION FACTOR (dB/m)
1	*2462.00	106.3 PK			2.63 V	344	73.40	32.90
2	*2462.00	95.8 AV			2.63 V	344	62.90	32.90
3	2483.50	64.7 PK	74.0	-9.3	2.72 V	5	31.70	33.00
4	2483.50	49.9 AV	54.0	-4.1	2.72 V	5	16.90	33.00
5	4924.00	49.4 PK	74.0	-24.6	1.09 V	165	43.40	6.00
6	4924.00	40.2 AV	54.0	-13.8	1.09 V	165	34.20	6.00

REMARKS:

1. Emission Level(dBuV/m) = Raw Value(dBuV) + Correction Factor(dB/m)
2. Correction Factor(dB/m) = Antenna Factor(dB/m) + Cable Factor(dB)
3. The other emission levels were very low against the limit.
4. Margin value = Emission Level – Limit value
5. " * " : Fundamental frequency.

802.11n (HT40)

CHANNEL	TX Channel 3	DETECTOR FUNCTION	Peak (PK)
FREQUENCY RANGE	1GHz ~ 25GHz		Average (AV)

ANTENNA POLARITY & TEST DISTANCE: HORIZONTAL AT 3 M

NO.	FREQ. (MHz)	EMISSION LEVEL (dBuV/m)	LIMIT (dBuV/m)	MARGIN (dB)	ANTENNA HEIGHT (m)	TABLE ANGLE (Degree)	RAW VALUE (dBuV)	CORRECTION FACTOR (dB/m)
1	2390.00	67.9 PK	74.0	-6.1	1.46 H	343	35.10	32.80
2	2390.00	52.7 AV	54.0	-1.3	1.46 H	343	19.90	32.80
3	*2422.00	105.9 PK			1.42 H	328	73.00	32.90
4	*2422.00	96.7 AV			1.42 H	328	63.80	32.90
5	4844.00	47.2 PK	74.0	-26.8	1.89 H	216	41.40	5.80
6	4844.00	34.2 AV	54.0	-19.8	1.89 H	216	28.40	5.80

ANTENNA POLARITY & TEST DISTANCE: VERTICAL AT 3 M

NO.	FREQ. (MHz)	EMISSION LEVEL (dBuV/m)	LIMIT (dBuV/m)	MARGIN (dB)	ANTENNA HEIGHT (m)	TABLE ANGLE (Degree)	RAW VALUE (dBuV)	CORRECTION FACTOR (dB/m)
1	2390.00	60.1 PK	74.0	-13.9	1.51 V	344	27.30	32.80
2	2390.00	47.4 AV	54.0	-6.6	1.51 V	344	14.60	32.80
3	*2422.00	101.3 PK			3.08 V	348	68.40	32.90
4	*2422.00	91.4 AV			3.08 V	348	58.50	32.90
5	4844.00	48.9 PK	74.0	-25.1	1.27 V	160	43.10	5.80
6	4844.00	39.4 AV	54.0	-14.6	1.27 V	160	33.60	5.80

REMARKS:

1. Emission Level(dBuV/m) = Raw Value(dBuV) + Correction Factor(dB/m)
2. Correction Factor(dB/m) = Antenna Factor(dB/m) + Cable Factor(dB)
3. The other emission levels were very low against the limit.
4. Margin value = Emission Level – Limit value
5. " * " : Fundamental frequency.

CHANNEL	TX Channel 6	DETECTOR FUNCTION	Peak (PK)
FREQUENCY RANGE	1GHz ~ 25GHz		Average (AV)

ANTENNA POLARITY & TEST DISTANCE: HORIZONTAL AT 3 M

NO.	FREQ. (MHz)	EMISSION LEVEL (dBuV/m)	LIMIT (dBuV/m)	MARGIN (dB)	ANTENNA HEIGHT (m)	TABLE ANGLE (Degree)	RAW VALUE (dBuV)	CORRECTION FACTOR (dB/m)
1	2390.00	66.7 PK	74.0	-7.3	2.31 H	330	33.90	32.80
2	2390.00	52.7 AV	54.0	-1.3	2.31 H	330	19.90	32.80
3	*2437.00	109.0 PK			2.36 H	41	76.10	32.90
4	*2437.00	99.2 AV			2.36 H	41	66.30	32.90
5	2483.50	65.3 PK	74.0	-8.7	2.74 H	35	32.30	33.00
6	2483.50	49.5 AV	54.0	-4.5	2.74 H	35	16.50	33.00
7	4874.00	47.0 PK	74.0	-27.0	2.37 H	198	41.00	6.00
8	4874.00	35.2 AV	54.0	-18.8	2.37 H	198	29.20	6.00

ANTENNA POLARITY & TEST DISTANCE: VERTICAL AT 3 M

NO.	FREQ. (MHz)	EMISSION LEVEL (dBuV/m)	LIMIT (dBuV/m)	MARGIN (dB)	ANTENNA HEIGHT (m)	TABLE ANGLE (Degree)	RAW VALUE (dBuV)	CORRECTION FACTOR (dB/m)
1	2390.00	58.5 PK	74.0	-15.5	1.51 V	214	25.70	32.80
2	2390.00	46.3 AV	54.0	-7.7	1.51 V	214	13.50	32.80
3	*2437.00	104.8 PK			3.03 V	350	71.90	32.90
4	*2437.00	95.0 AV			3.03 V	350	62.10	32.90
5	2483.50	56.7 PK	74.0	-17.3	1.88 V	275	23.70	33.00
6	2483.50	45.2 AV	54.0	-8.8	1.88 V	275	12.20	33.00
7	4874.00	49.0 PK	74.0	-25.0	1.11 V	161	43.00	6.00
8	4874.00	38.5 AV	54.0	-15.5	1.11 V	161	32.50	6.00

REMARKS:

1. Emission Level(dBuV/m) = Raw Value(dBuV) + Correction Factor(dB/m)
2. Correction Factor(dB/m) = Antenna Factor(dB/m) + Cable Factor(dB)
3. The other emission levels were very low against the limit.
4. Margin value = Emission Level – Limit value
5. " * ": Fundamental frequency.

CHANNEL	TX Channel 9	DETECTOR FUNCTION	Peak (PK)
FREQUENCY RANGE	1GHz ~ 25GHz		Average (AV)

ANTENNA POLARITY & TEST DISTANCE: HORIZONTAL AT 3 M

NO.	FREQ. (MHz)	EMISSION LEVEL (dBuV/m)	LIMIT (dBuV/m)	MARGIN (dB)	ANTENNA HEIGHT (m)	TABLE ANGLE (Degree)	RAW VALUE (dBuV)	CORRECTION FACTOR (dB/m)
1	*2452.00	107.0 PK			1.72 H	319	74.00	33.00
2	*2452.00	97.1 AV			1.72 H	319	64.10	33.00
3	2483.50	64.4 PK	74.0	-9.6	2.28 H	29	31.40	33.00
4	2483.50	52.8 AV	54.0	-1.2	2.28 H	29	19.80	33.00
5	4904.00	47.5 PK	74.0	-26.5	1.87 H	140	41.60	5.90
6	4904.00	34.7 AV	54.0	-19.3	1.87 H	140	28.80	5.90

ANTENNA POLARITY & TEST DISTANCE: VERTICAL AT 3 M

NO.	FREQ. (MHz)	EMISSION LEVEL (dBuV/m)	LIMIT (dBuV/m)	MARGIN (dB)	ANTENNA HEIGHT (m)	TABLE ANGLE (Degree)	RAW VALUE (dBuV)	CORRECTION FACTOR (dB/m)
1	*2452.00	103.3 PK			2.93 V	357	70.30	33.00
2	*2452.00	93.4 AV			2.93 V	357	60.40	33.00
3	2483.50	57.0 PK	74.0	-17.0	1.69 V	96	24.00	33.00
4	2483.50	45.9 AV	54.0	-8.1	1.69 V	96	12.90	33.00
5	4904.00	49.3 PK	74.0	-24.7	1.26 V	168	43.40	5.90
6	4904.00	39.9 AV	54.0	-14.1	1.26 V	168	34.00	5.90

REMARKS:

1. Emission Level(dBuV/m) = Raw Value(dBuV) + Correction Factor(dB/m)
2. Correction Factor(dB/m) = Antenna Factor(dB/m) + Cable Factor(dB)
3. The other emission levels were very low against the limit.
4. Margin value = Emission Level – Limit value
5. " * " : Fundamental frequency.

Radio 1: Beamforming Mode

802.11n (HT20)

CHANNEL	TX Channel 1	DETECTOR FUNCTION	Peak (PK)
FREQUENCY RANGE	1GHz ~ 25GHz		Average (AV)

ANTENNA POLARITY & TEST DISTANCE: HORIZONTAL AT 3 M

NO.	FREQ. (MHz)	EMISSION LEVEL (dBuV/m)	LIMIT (dBuV/m)	MARGIN (dB)	ANTENNA HEIGHT (m)	TABLE ANGLE (Degree)	RAW VALUE (dBuV)	CORRECTION FACTOR (dB/m)
1	2390.00	63.9 PK	74.0	-10.1	1.46 H	298	31.10	32.80
2	2390.00	49.9 AV	54.0	-4.1	1.46 H	298	17.10	32.80
3	*2412.00	110.3 PK			1.83 H	298	77.40	32.90
4	*2412.00	99.3 AV			1.83 H	298	66.40	32.90
5	4824.00	46.4 PK	74.0	-27.6	1.86 H	308	40.50	5.90
6	4824.00	33.9 AV	54.0	-20.1	1.86 H	308	28.00	5.90

ANTENNA POLARITY & TEST DISTANCE: VERTICAL AT 3 M

NO.	FREQ. (MHz)	EMISSION LEVEL (dBuV/m)	LIMIT (dBuV/m)	MARGIN (dB)	ANTENNA HEIGHT (m)	TABLE ANGLE (Degree)	RAW VALUE (dBuV)	CORRECTION FACTOR (dB/m)
1	2390.00	60.0 PK	74.0	-14.0	1.77 V	69	27.20	32.80
2	2390.00	48.3 AV	54.0	-5.7	1.77 V	69	15.50	32.80
3	*2412.00	103.1 PK			1.82 V	349	70.20	32.90
4	*2412.00	92.0 AV			1.82 V	349	59.10	32.90
5	4824.00	48.3 PK	74.0	-25.7	1.63 V	171	42.40	5.90
6	4824.00	40.2 AV	54.0	-13.8	1.63 V	171	34.30	5.90

REMARKS:

1. Emission Level(dBuV/m) = Raw Value(dBuV) + Correction Factor(dB/m)
2. Correction Factor(dB/m) = Antenna Factor(dB/m) + Cable Factor(dB)
3. The other emission levels were very low against the limit.
4. Margin value = Emission Level – Limit value
5. " * " : Fundamental frequency.

CHANNEL	TX Channel 6	DETECTOR FUNCTION	Peak (PK)
FREQUENCY RANGE	1GHz ~ 25GHz		Average (AV)

ANTENNA POLARITY & TEST DISTANCE: HORIZONTAL AT 3 M

NO.	FREQ. (MHz)	EMISSION LEVEL (dBuV/m)	LIMIT (dBuV/m)	MARGIN (dB)	ANTENNA HEIGHT (m)	TABLE ANGLE (Degree)	RAW VALUE (dBuV)	CORRECTION FACTOR (dB/m)
1	*2437.00	116.3 PK			1.47 H	319	83.40	32.90
2	*2437.00	104.0 AV			1.47 H	319	71.10	32.90
3	4874.00	49.2 PK	74.0	-24.8	1.41 H	300	43.20	6.00
4	4874.00	43.8 AV	54.0	-10.2	1.41 H	300	37.80	6.00

ANTENNA POLARITY & TEST DISTANCE: VERTICAL AT 3 M

NO.	FREQ. (MHz)	EMISSION LEVEL (dBuV/m)	LIMIT (dBuV/m)	MARGIN (dB)	ANTENNA HEIGHT (m)	TABLE ANGLE (Degree)	RAW VALUE (dBuV)	CORRECTION FACTOR (dB/m)
1	*2437.00	112.6 PK			2.95 V	352	79.70	32.90
2	*2437.00	101.8 AV			2.95 V	352	68.90	32.90
3	4874.00	48.5 PK	74.0	-25.5	2.97 V	149	42.50	6.00
4	4874.00	39.0 AV	54.0	-15.0	2.97 V	149	33.00	6.00

REMARKS:

1. Emission Level(dBuV/m) = Raw Value(dBuV) + Correction Factor(dB/m)
2. Correction Factor(dB/m) = Antenna Factor(dB/m) + Cable Factor(dB)
3. The other emission levels were very low against the limit.
4. Margin value = Emission Level – Limit value
5. " * " : Fundamental frequency.

CHANNEL	TX Channel 11	DETECTOR FUNCTION	Peak (PK)
FREQUENCY RANGE	1GHz ~ 25GHz		Average (AV)

ANTENNA POLARITY & TEST DISTANCE: HORIZONTAL AT 3 M

NO.	FREQ. (MHz)	EMISSION LEVEL (dBuV/m)	LIMIT (dBuV/m)	MARGIN (dB)	ANTENNA HEIGHT (m)	TABLE ANGLE (Degree)	RAW VALUE (dBuV)	CORRECTION FACTOR (dB/m)
1	*2462.00	111.1 PK			1.61 H	330	78.20	32.90
2	*2462.00	101.0 AV			1.61 H	330	68.10	32.90
3	2483.50	64.1 PK	74.0	-9.9	1.82 H	310	31.10	33.00
4	2483.50	50.8 AV	54.0	-3.2	1.82 H	310	17.80	33.00
5	4924.00	47.5 PK	74.0	-26.5	1.49 H	270	41.50	6.00
6	4924.00	36.6 AV	54.0	-17.4	1.49 H	270	30.60	6.00

ANTENNA POLARITY & TEST DISTANCE: VERTICAL AT 3 M

NO.	FREQ. (MHz)	EMISSION LEVEL (dBuV/m)	LIMIT (dBuV/m)	MARGIN (dB)	ANTENNA HEIGHT (m)	TABLE ANGLE (Degree)	RAW VALUE (dBuV)	CORRECTION FACTOR (dB/m)
1	*2462.00	107.3 PK			2.82 V	357	74.40	32.90
2	*2462.00	99.5 AV			2.82 V	357	66.60	32.90
3	2483.50	64.5 PK	74.0	-9.5	1.80 V	269	31.50	33.00
4	2483.50	52.1 AV	54.0	-1.9	1.80 V	269	19.10	33.00
5	4924.00	47.6 PK	74.0	-26.4	1.60 V	138	41.60	6.00
6	4924.00	37.0 AV	54.0	-17.0	1.60 V	138	31.00	6.00

REMARKS:

1. Emission Level(dBuV/m) = Raw Value(dBuV) + Correction Factor(dB/m)
2. Correction Factor(dB/m) = Antenna Factor(dB/m) + Cable Factor(dB)
3. The other emission levels were very low against the limit.
4. Margin value = Emission Level – Limit value
5. " * " : Fundamental frequency.

802.11n (HT40)

CHANNEL	TX Channel 3	DETECTOR FUNCTION	Peak (PK)
FREQUENCY RANGE	1GHz ~ 25GHz		Average (AV)

ANTENNA POLARITY & TEST DISTANCE: HORIZONTAL AT 3 M

NO.	FREQ. (MHz)	EMISSION LEVEL (dBuV/m)	LIMIT (dBuV/m)	MARGIN (dB)	ANTENNA HEIGHT (m)	TABLE ANGLE (Degree)	RAW VALUE (dBuV)	CORRECTION FACTOR (dB/m)
1	2390.00	71.0 PK	74.0	-3.0	1.72 H	355	38.20	32.80
2	2390.00	52.3 AV	54.0	-1.7	1.72 H	355	19.50	32.80
3	*2422.00	105.0 PK			1.55 H	316	72.10	32.90
4	*2422.00	92.7 AV			1.55 H	316	59.80	32.90
5	4844.00	46.7 PK	74.0	-27.3	1.95 H	299	40.90	5.80
6	4844.00	33.8 AV	54.0	-20.2	1.95 H	299	28.00	5.80

ANTENNA POLARITY & TEST DISTANCE: VERTICAL AT 3 M

NO.	FREQ. (MHz)	EMISSION LEVEL (dBuV/m)	LIMIT (dBuV/m)	MARGIN (dB)	ANTENNA HEIGHT (m)	TABLE ANGLE (Degree)	RAW VALUE (dBuV)	CORRECTION FACTOR (dB/m)
1	2390.00	62.8 PK	74.0	-11.2	3.12 V	332	30.00	32.80
2	2390.00	49.8 AV	54.0	-4.2	3.12 V	332	17.00	32.80
3	*2422.00	102.4 PK			3.31 V	355	69.50	32.90
4	*2422.00	92.1 AV			3.31 V	355	59.20	32.90
5	4844.00	47.4 PK	74.0	-26.6	2.65 V	159	41.60	5.80
6	4844.00	38.8 AV	54.0	-15.2	2.65 V	159	33.00	5.80

REMARKS:

1. Emission Level(dBuV/m) = Raw Value(dBuV) + Correction Factor(dB/m)
2. Correction Factor(dB/m) = Antenna Factor(dB/m) + Cable Factor(dB)
3. The other emission levels were very low against the limit.
4. Margin value = Emission Level – Limit value
5. " * " : Fundamental frequency.

CHANNEL	TX Channel 6	DETECTOR FUNCTION	Peak (PK)
FREQUENCY RANGE	1GHz ~ 25GHz		Average (AV)

ANTENNA POLARITY & TEST DISTANCE: HORIZONTAL AT 3 M

NO.	FREQ. (MHz)	EMISSION LEVEL (dBuV/m)	LIMIT (dBuV/m)	MARGIN (dB)	ANTENNA HEIGHT (m)	TABLE ANGLE (Degree)	RAW VALUE (dBuV)	CORRECTION FACTOR (dB/m)
1	2390.00	68.8 PK	74.0	-5.2	1.44 H	321	36.00	32.80
2	2390.00	50.3 AV	54.0	-3.7	1.44 H	321	17.50	32.80
3	*2437.00	110.0 PK			1.43 H	309	77.10	32.90
4	*2437.00	96.1 AV			1.43 H	309	63.20	32.90
5	2483.50	69.3 PK	74.0	-4.7	1.38 H	308	36.30	33.00
6	2483.50	49.8 AV	54.0	-4.2	1.38 H	308	16.80	33.00
7	4874.00	46.8 PK	74.0	-27.2	2.14 H	225	40.80	6.00
8	4874.00	34.2 AV	54.0	-19.8	2.14 H	225	28.20	6.00

ANTENNA POLARITY & TEST DISTANCE: VERTICAL AT 3 M

NO.	FREQ. (MHz)	EMISSION LEVEL (dBuV/m)	LIMIT (dBuV/m)	MARGIN (dB)	ANTENNA HEIGHT (m)	TABLE ANGLE (Degree)	RAW VALUE (dBuV)	CORRECTION FACTOR (dB/m)
1	2390.00	66.0 PK	74.0	-8.0	3.46 V	13	33.20	32.80
2	2390.00	50.6 AV	54.0	-3.4	3.46 V	13	17.80	32.80
3	*2437.00	108.0 PK			3.26 V	345	75.10	32.90
4	*2437.00	96.5 AV			3.26 V	345	63.60	32.90
5	2483.50	62.6 PK	74.0	-11.4	3.24 V	352	29.60	33.00
6	2483.50	48.5 AV	54.0	-5.5	3.24 V	352	15.50	33.00
7	4874.00	48.2 PK	74.0	-25.8	2.94 V	147	42.20	6.00
8	4874.00	38.5 AV	54.0	-15.5	2.94 V	147	32.50	6.00

REMARKS:

1. Emission Level(dBuV/m) = Raw Value(dBuV) + Correction Factor(dB/m)
2. Correction Factor(dB/m) = Antenna Factor(dB/m) + Cable Factor(dB)
3. The other emission levels were very low against the limit.
4. Margin value = Emission Level – Limit value
5. " * ": Fundamental frequency.

CHANNEL	TX Channel 9	DETECTOR FUNCTION	Peak (PK)
FREQUENCY RANGE	1GHz ~ 25GHz		Average (AV)

ANTENNA POLARITY & TEST DISTANCE: HORIZONTAL AT 3 M

NO.	FREQ. (MHz)	EMISSION LEVEL (dBuV/m)	LIMIT (dBuV/m)	MARGIN (dB)	ANTENNA HEIGHT (m)	TABLE ANGLE (Degree)	RAW VALUE (dBuV)	CORRECTION FACTOR (dB/m)
1	*2452.00	108.8 PK			1.44 H	324	75.80	33.00
2	*2452.00	98.6 AV			1.44 H	324	65.60	33.00
3	2483.50	65.3 PK	74.0	-8.7	1.46 H	295	32.30	33.00
4	2483.50	52.6 AV	54.0	-1.4	1.46 H	295	19.60	33.00
5	4904.00	47.7 PK	74.0	-26.3	1.87 H	156	41.80	5.90
6	4904.00	34.6 AV	54.0	-19.4	1.87 H	156	28.70	5.90

ANTENNA POLARITY & TEST DISTANCE: VERTICAL AT 3 M

NO.	FREQ. (MHz)	EMISSION LEVEL (dBuV/m)	LIMIT (dBuV/m)	MARGIN (dB)	ANTENNA HEIGHT (m)	TABLE ANGLE (Degree)	RAW VALUE (dBuV)	CORRECTION FACTOR (dB/m)
1	*2452.00	106.6 PK			3.27 V	4	73.60	33.00
2	*2452.00	95.6 AV			3.27 V	4	62.60	33.00
3	2483.50	57.6 PK	74.0	-16.4	2.16 V	288	24.60	33.00
4	2483.50	45.8 AV	54.0	-8.2	2.16 V	288	12.80	33.00
5	4904.00	47.1 PK	74.0	-26.9	2.22 V	158	41.20	5.90
6	4904.00	34.4 AV	54.0	-19.6	2.22 V	158	28.50	5.90

REMARKS:

1. Emission Level(dBuV/m) = Raw Value(dBuV) + Correction Factor(dB/m)
2. Correction Factor(dB/m) = Antenna Factor(dB/m) + Cable Factor(dB)
3. The other emission levels were very low against the limit.
4. Margin value = Emission Level – Limit value
5. " * " : Fundamental frequency.

Radio 3: CDD Mode

802.11b

CHANNEL	TX Channel 1	DETECTOR FUNCTION	Peak (PK)
FREQUENCY RANGE	1GHz ~ 25GHz		Average (AV)

ANTENNA POLARITY & TEST DISTANCE: HORIZONTAL AT 3 M

NO.	FREQ. (MHz)	EMISSION LEVEL (dBuV/m)	LIMIT (dBuV/m)	MARGIN (dB)	ANTENNA HEIGHT (m)	TABLE ANGLE (Degree)	RAW VALUE (dBuV)	CORRECTION FACTOR (dB/m)
1	2360.00	57.6 PK	74.0	-16.4	1.82 H	312	24.90	32.70
2	2360.00	46.8 AV	54.0	-7.2	1.82 H	312	14.10	32.70
3	*2412.00	103.9 PK			2.00 H	319	71.00	32.90
4	*2412.00	101.8 AV			2.00 H	319	68.90	32.90
5	4824.00	55.3 PK	74.0	-18.7	1.88 H	14	49.40	5.90
6	4824.00	51.8 AV	54.0	-2.2	1.88 H	14	45.90	5.90
7	#7236.00	58.2 PK	83.9	-25.7	2.64 H	193	44.90	13.30
8	#7236.00	51.0 AV	71.8	-20.8	2.64 H	193	37.70	13.30

ANTENNA POLARITY & TEST DISTANCE: VERTICAL AT 3 M

NO.	FREQ. (MHz)	EMISSION LEVEL (dBuV/m)	LIMIT (dBuV/m)	MARGIN (dB)	ANTENNA HEIGHT (m)	TABLE ANGLE (Degree)	RAW VALUE (dBuV)	CORRECTION FACTOR (dB/m)
1	2360.00	57.9 PK	74.0	-16.1	1.54 V	324	25.20	32.70
2	2360.00	48.4 AV	54.0	-5.6	1.54 V	324	15.70	32.70
3	*2412.00	106.2 PK			1.00 V	4	73.30	32.90
4	*2412.00	104.1 AV			1.00 V	4	71.20	32.90
5	4824.00	57.0 PK	74.0	-17.0	2.02 V	294	51.10	5.90
6	4824.00	52.7 AV	54.0	-1.3	2.02 V	294	46.80	5.90
7	#7236.00	60.5 PK	86.2	-25.7	2.84 V	150	47.20	13.30
8	#7236.00	54.1 AV	74.1	-20.0	2.84 V	150	40.80	13.30

REMARKS:

1. Emission Level(dBuV/m) = Raw Value(dBuV) + Correction Factor(dB/m)
2. Correction Factor(dB/m) = Antenna Factor(dB/m) + Cable Factor(dB)
3. The other emission levels were very low against the limit.
4. Margin value = Emission Level – Limit value
5. " * ": Fundamental frequency.
6. " # ": The radiated frequency is out of the restricted band.

CHANNEL	TX Channel 6	DETECTOR FUNCTION	Peak (PK)
FREQUENCY RANGE	1GHz ~ 25GHz		Average (AV)

ANTENNA POLARITY & TEST DISTANCE: HORIZONTAL AT 3 M

NO.	FREQ. (MHz)	EMISSION LEVEL (dBuV/m)	LIMIT (dBuV/m)	MARGIN (dB)	ANTENNA HEIGHT (m)	TABLE ANGLE (Degree)	RAW VALUE (dBuV)	CORRECTION FACTOR (dB/m)
1	2390.00	57.6 PK	74.0	-16.4	1.51 H	326	24.80	32.80
2	2390.00	47.2 AV	54.0	-6.8	1.51 H	326	14.40	32.80
3	*2437.00	104.0 PK			1.23 H	333	71.10	32.90
4	*2437.00	100.1 AV			1.23 H	333	67.20	32.90
5	2483.50	59.8 PK	74.0	-14.2	1.11 H	338	26.80	33.00
6	2483.50	50.4 AV	54.0	-3.6	1.11 H	338	17.40	33.00
7	4874.00	50.4 PK	74.0	-23.6	2.38 H	191	44.40	6.00
8	4874.00	44.3 AV	54.0	-9.7	2.38 H	191	38.30	6.00
9	7311.00	56.4 PK	74.0	-17.6	2.39 H	111	43.10	13.30
10	7311.00	49.9 AV	54.0	-4.1	2.39 H	111	36.60	13.30

ANTENNA POLARITY & TEST DISTANCE: VERTICAL AT 3 M

NO.	FREQ. (MHz)	EMISSION LEVEL (dBuV/m)	LIMIT (dBuV/m)	MARGIN (dB)	ANTENNA HEIGHT (m)	TABLE ANGLE (Degree)	RAW VALUE (dBuV)	CORRECTION FACTOR (dB/m)
1	2390.00	58.3 PK	74.0	-15.7	1.06 V	346	25.50	32.80
2	2390.00	49.9 AV	54.0	-4.1	1.06 V	346	17.10	32.80
3	*2437.00	106.2 PK			1.05 V	347	73.30	32.90
4	*2437.00	102.4 AV			1.05 V	347	69.50	32.90
5	2483.50	60.3 PK	74.0	-13.7	1.18 V	6	27.30	33.00
6	2483.50	52.6 AV	54.0	-1.4	1.18 V	6	19.60	33.00
7	4874.00	54.1 PK	74.0	-19.9	2.01 V	297	48.10	6.00
8	4874.00	51.6 AV	54.0	-2.4	2.01 V	297	45.60	6.00
9	7311.00	60.4 PK	74.0	-13.6	1.60 V	157	47.10	13.30
10	7311.00	52.9 AV	54.0	-1.1	1.60 V	157	39.60	13.30

REMARKS:

1. Emission Level(dBuV/m) = Raw Value(dBuV) + Correction Factor(dB/m)
2. Correction Factor(dB/m) = Antenna Factor(dB/m) + Cable Factor(dB)
3. The other emission levels were very low against the limit.
4. Margin value = Emission Level – Limit value
5. " * ": Fundamental frequency.

CHANNEL	TX Channel 11	DETECTOR FUNCTION	Peak (PK)
FREQUENCY RANGE	1GHz ~ 25GHz		Average (AV)

ANTENNA POLARITY & TEST DISTANCE: HORIZONTAL AT 3 M

NO.	FREQ. (MHz)	EMISSION LEVEL (dBuV/m)	LIMIT (dBuV/m)	MARGIN (dB)	ANTENNA HEIGHT (m)	TABLE ANGLE (Degree)	RAW VALUE (dBuV)	CORRECTION FACTOR (dB/m)
1	*2462.00	105.8 PK			1.34 H	329	72.90	32.90
2	*2462.00	101.8 AV			1.34 H	329	68.90	32.90
3	2499.00	58.6 PK	74.0	-15.4	1.54 H	334	25.60	33.00
4	2499.00	46.7 AV	54.0	-7.3	1.54 H	334	13.70	33.00
5	4924.00	57.0 PK	74.0	-17.0	2.10 H	354	51.00	6.00
6	4924.00	52.8 AV	54.0	-1.2	2.10 H	354	46.80	6.00
7	7386.00	57.2 PK	74.0	-16.8	1.66 H	234	44.00	13.20
8	7386.00	48.2 AV	54.0	-5.8	1.66 H	234	35.00	13.20

ANTENNA POLARITY & TEST DISTANCE: VERTICAL AT 3 M

NO.	FREQ. (MHz)	EMISSION LEVEL (dBuV/m)	LIMIT (dBuV/m)	MARGIN (dB)	ANTENNA HEIGHT (m)	TABLE ANGLE (Degree)	RAW VALUE (dBuV)	CORRECTION FACTOR (dB/m)
1	*2462.00	108.4 PK			1.24 V	348	75.50	32.90
2	*2462.00	106.9 AV			1.24 V	348	74.00	32.90
3	2499.00	58.3 PK	74.0	-15.7	1.18 V	355	25.30	33.00
4	2499.00	47.5 AV	54.0	-6.5	1.18 V	355	14.50	33.00
5	4924.00	56.3 PK	74.0	-17.7	1.65 V	307	50.30	6.00
6	4924.00	52.4 AV	54.0	-1.6	1.65 V	307	46.40	6.00
7	7386.00	59.7 PK	74.0	-14.3	1.77 V	155	46.50	13.20
8	7386.00	51.8 AV	54.0	-2.2	1.77 V	155	38.60	13.20

REMARKS:

1. Emission Level(dBuV/m) = Raw Value(dBuV) + Correction Factor(dB/m)
2. Correction Factor(dB/m) = Antenna Factor(dB/m) + Cable Factor(dB)
3. The other emission levels were very low against the limit.
4. Margin value = Emission Level – Limit value
5. " * ": Fundamental frequency.

802.11g

CHANNEL	TX Channel 1	DETECTOR FUNCTION	Peak (PK)
FREQUENCY RANGE	1GHz ~ 25GHz		Average (AV)

ANTENNA POLARITY & TEST DISTANCE: HORIZONTAL AT 3 M								
NO.	FREQ. (MHz)	EMISSION LEVEL (dBuV/m)	LIMIT (dBuV/m)	MARGIN (dB)	ANTENNA HEIGHT (m)	TABLE ANGLE (Degree)	RAW VALUE (dBuV)	CORRECTION FACTOR (dB/m)
1	2390.00	63.4 PK	74.0	-10.6	1.80 H	301	30.60	32.80
2	2390.00	50.6 AV	54.0	-3.4	1.80 H	301	17.80	32.80
3	*2412.00	103.6 PK			2.05 H	323	70.70	32.90
4	*2412.00	93.8 AV			2.05 H	323	60.90	32.90
5	4824.00	48.6 PK	74.0	-25.4	2.12 H	22	42.70	5.90
6	4824.00	36.4 AV	54.0	-17.6	2.12 H	22	30.50	5.90
ANTENNA POLARITY & TEST DISTANCE: VERTICAL AT 3 M								
NO.	FREQ. (MHz)	EMISSION LEVEL (dBuV/m)	LIMIT (dBuV/m)	MARGIN (dB)	ANTENNA HEIGHT (m)	TABLE ANGLE (Degree)	RAW VALUE (dBuV)	CORRECTION FACTOR (dB/m)
1	2390.00	65.5 PK	74.0	-8.5	1.52 V	349	32.70	32.80
2	2390.00	52.5 AV	54.0	-1.5	1.52 V	349	19.70	32.80
3	*2412.00	105.6 PK			1.02 V	1	72.70	32.90
4	*2412.00	95.7 AV			1.02 V	1	62.80	32.90
5	4824.00	49.5 PK	74.0	-24.5	1.03 V	161	43.60	5.90
6	4824.00	40.6 AV	54.0	-13.4	1.03 V	161	34.70	5.90

REMARKS:

1. Emission Level(dBuV/m) = Raw Value(dBuV) + Correction Factor(dB/m)
2. Correction Factor(dB/m) = Antenna Factor(dB/m) + Cable Factor(dB)
3. The other emission levels were very low against the limit.
4. Margin value = Emission Level – Limit value
5. " * " : Fundamental frequency.

CHANNEL	TX Channel 6	DETECTOR FUNCTION	Peak (PK)
FREQUENCY RANGE	1GHz ~ 25GHz		Average (AV)

ANTENNA POLARITY & TEST DISTANCE: HORIZONTAL AT 3 M

NO.	FREQ. (MHz)	EMISSION LEVEL (dBuV/m)	LIMIT (dBuV/m)	MARGIN (dB)	ANTENNA HEIGHT (m)	TABLE ANGLE (Degree)	RAW VALUE (dBuV)	CORRECTION FACTOR (dB/m)
1	2390.00	56.7 PK	74.0	-17.3	1.86 H	330	23.90	32.80
2	2390.00	46.2 AV	54.0	-7.8	1.86 H	330	13.40	32.80
3	*2437.00	105.2 PK			1.96 H	325	72.30	32.90
4	*2437.00	95.4 AV			1.96 H	325	62.50	32.90
5	2483.50	59.1 PK	74.0	-14.9	1.90 H	333	26.10	33.00
6	2483.50	49.1 AV	54.0	-4.9	1.90 H	333	16.10	33.00
7	4874.00	51.4 PK	74.0	-22.6	2.02 H	19	45.40	6.00
8	4874.00	41.3 AV	54.0	-12.7	2.02 H	19	35.30	6.00
9	7311.00	55.8 PK	74.0	-18.2	1.74 H	218	42.50	13.30
10	7311.00	43.8 AV	54.0	-10.2	1.74 H	218	30.50	13.30

ANTENNA POLARITY & TEST DISTANCE: VERTICAL AT 3 M

NO.	FREQ. (MHz)	EMISSION LEVEL (dBuV/m)	LIMIT (dBuV/m)	MARGIN (dB)	ANTENNA HEIGHT (m)	TABLE ANGLE (Degree)	RAW VALUE (dBuV)	CORRECTION FACTOR (dB/m)
1	2390.00	60.2 PK	74.0	-13.8	1.19 V	337	27.40	32.80
2	2390.00	49.2 AV	54.0	-4.8	1.19 V	337	16.40	32.80
3	*2437.00	109.0 PK			1.23 V	353	76.10	32.90
4	*2437.00	99.0 AV			1.23 V	353	66.10	32.90
5	2483.50	63.7 PK	74.0	-10.3	1.15 V	353	30.70	33.00
6	2483.50	52.1 AV	54.0	-1.9	1.15 V	353	19.10	33.00
7	4874.00	54.5 PK	74.0	-19.5	2.12 V	346	48.50	6.00
8	4874.00	40.7 AV	54.0	-13.3	2.12 V	346	34.70	6.00
9	7311.00	58.5 PK	74.0	-15.5	2.12 V	144	45.20	13.30
10	7311.00	45.8 AV	54.0	-8.2	2.12 V	144	32.50	13.30

REMARKS:

1. Emission Level(dBuV/m) = Raw Value(dBuV) + Correction Factor(dB/m)
2. Correction Factor(dB/m) = Antenna Factor(dB/m) + Cable Factor(dB)
3. The other emission levels were very low against the limit.
4. Margin value = Emission Level – Limit value
5. " * ": Fundamental frequency.

CHANNEL	TX Channel 11	DETECTOR FUNCTION	Peak (PK)
FREQUENCY RANGE	1GHz ~ 25GHz		Average (AV)

ANTENNA POLARITY & TEST DISTANCE: HORIZONTAL AT 3 M

NO.	FREQ. (MHz)	EMISSION LEVEL (dBuV/m)	LIMIT (dBuV/m)	MARGIN (dB)	ANTENNA HEIGHT (m)	TABLE ANGLE (Degree)	RAW VALUE (dBuV)	CORRECTION FACTOR (dB/m)
1	*2462.00	103.4 PK			1.31 H	336	70.50	32.90
2	*2462.00	93.7 AV			1.31 H	336	60.80	32.90
3	2483.50	65.7 PK	74.0	-8.3	1.24 H	331	32.70	33.00
4	2483.50	50.3 AV	54.0	-3.7	1.24 H	331	17.30	33.00
5	4924.00	49.8 PK	74.0	-24.2	2.00 H	19	43.80	6.00
6	4924.00	37.0 AV	54.0	-17.0	2.00 H	19	31.00	6.00

ANTENNA POLARITY & TEST DISTANCE: VERTICAL AT 3 M

NO.	FREQ. (MHz)	EMISSION LEVEL (dBuV/m)	LIMIT (dBuV/m)	MARGIN (dB)	ANTENNA HEIGHT (m)	TABLE ANGLE (Degree)	RAW VALUE (dBuV)	CORRECTION FACTOR (dB/m)
1	*2462.00	106.9 PK			1.00 V	359	74.00	32.90
2	*2462.00	96.7 AV			1.00 V	359	63.80	32.90
3	2483.50	67.4 PK	74.0	-6.6	1.20 V	1	34.40	33.00
4	2483.50	52.8 AV	54.0	-1.2	1.20 V	1	19.80	33.00
5	4924.00	52.9 PK	74.0	-21.1	1.86 V	169	46.90	6.00
6	4924.00	40.7 AV	54.0	-13.3	1.86 V	169	34.70	6.00

REMARKS:

1. Emission Level(dBuV/m) = Raw Value(dBuV) + Correction Factor(dB/m)
2. Correction Factor(dB/m) = Antenna Factor(dB/m) + Cable Factor(dB)
3. The other emission levels were very low against the limit.
4. Margin value = Emission Level – Limit value
5. " * " : Fundamental frequency.

802.11n (HT20)

CHANNEL	TX Channel 1	DETECTOR FUNCTION	Peak (PK)
FREQUENCY RANGE	1GHz ~ 25GHz		Average (AV)

ANTENNA POLARITY & TEST DISTANCE: HORIZONTAL AT 3 M

NO.	FREQ. (MHz)	EMISSION LEVEL (dBuV/m)	LIMIT (dBuV/m)	MARGIN (dB)	ANTENNA HEIGHT (m)	TABLE ANGLE (Degree)	RAW VALUE (dBuV)	CORRECTION FACTOR (dB/m)
1	2390.00	62.4 PK	74.0	-11.6	1.56 H	322	29.60	32.80
2	2390.00	49.0 AV	54.0	-5.0	1.56 H	322	16.20	32.80
3	*2412.00	101.6 PK			1.45 H	322	68.70	32.90
4	*2412.00	91.5 AV			1.45 H	322	58.60	32.90
5	4824.00	47.6 PK	74.0	-26.4	1.50 H	197	41.70	5.90
6	4824.00	35.2 AV	54.0	-18.8	1.50 H	197	29.30	5.90

ANTENNA POLARITY & TEST DISTANCE: VERTICAL AT 3 M

NO.	FREQ. (MHz)	EMISSION LEVEL (dBuV/m)	LIMIT (dBuV/m)	MARGIN (dB)	ANTENNA HEIGHT (m)	TABLE ANGLE (Degree)	RAW VALUE (dBuV)	CORRECTION FACTOR (dB/m)
1	2390.00	67.1 PK	74.0	-6.9	1.00 V	345	34.30	32.80
2	2390.00	52.6 AV	54.0	-1.4	1.00 V	345	19.80	32.80
3	*2412.00	104.4 PK			1.14 V	346	71.50	32.90
4	*2412.00	94.7 AV			1.14 V	346	61.80	32.90
5	4824.00	49.3 PK	74.0	-24.7	1.33 V	166	43.40	5.90
6	4824.00	39.3 AV	54.0	-14.7	1.33 V	166	33.40	5.90

REMARKS:

1. Emission Level(dBuV/m) = Raw Value(dBuV) + Correction Factor(dB/m)
2. Correction Factor(dB/m) = Antenna Factor(dB/m) + Cable Factor(dB)
3. The other emission levels were very low against the limit.
4. Margin value = Emission Level – Limit value
5. " * ": Fundamental frequency.

CHANNEL	TX Channel 6	DETECTOR FUNCTION	Peak (PK)
FREQUENCY RANGE	1GHz ~ 25GHz		Average (AV)

ANTENNA POLARITY & TEST DISTANCE: HORIZONTAL AT 3 M

NO.	FREQ. (MHz)	EMISSION LEVEL (dBuV/m)	LIMIT (dBuV/m)	MARGIN (dB)	ANTENNA HEIGHT (m)	TABLE ANGLE (Degree)	RAW VALUE (dBuV)	CORRECTION FACTOR (dB/m)
1	2390.00	58.7 PK	74.0	-15.3	1.80 H	317	25.90	32.80
2	2390.00	46.6 AV	54.0	-7.4	1.80 H	317	13.80	32.80
3	*2437.00	105.0 PK			1.39 H	326	72.10	32.90
4	*2437.00	95.2 AV			1.39 H	326	62.30	32.90
5	2483.50	60.9 PK	74.0	-13.1	1.26 H	333	27.90	33.00
6	2483.50	49.0 AV	54.0	-5.0	1.26 H	333	16.00	33.00
7	4874.00	50.4 PK	74.0	-23.6	1.96 H	214	44.40	6.00
8	4874.00	36.3 AV	54.0	-17.7	1.96 H	214	30.30	6.00
9	7311.00	54.2 PK	74.0	-19.8	1.95 H	154	40.90	13.30
10	7311.00	42.2 AV	54.0	-11.8	1.95 H	154	28.90	13.30

ANTENNA POLARITY & TEST DISTANCE: VERTICAL AT 3 M

NO.	FREQ. (MHz)	EMISSION LEVEL (dBuV/m)	LIMIT (dBuV/m)	MARGIN (dB)	ANTENNA HEIGHT (m)	TABLE ANGLE (Degree)	RAW VALUE (dBuV)	CORRECTION FACTOR (dB/m)
1	2390.00	59.0 PK	74.0	-15.0	1.48 V	338	26.20	32.80
2	2390.00	47.8 AV	54.0	-6.2	1.48 V	338	15.00	32.80
3	*2437.00	107.4 PK			1.30 V	349	74.50	32.90
4	*2437.00	97.4 AV			1.30 V	349	64.50	32.90
5	2483.50	62.5 PK	74.0	-11.5	1.16 V	357	29.50	33.00
6	2483.50	50.6 AV	54.0	-3.4	1.16 V	357	17.60	33.00
7	4874.00	54.4 PK	74.0	-19.6	2.03 V	297	48.40	6.00
8	4874.00	39.6 AV	54.0	-14.4	2.03 V	297	33.60	6.00
9	7311.00	59.8 PK	74.0	-14.2	1.81 V	157	46.50	13.30
10	7311.00	46.2 AV	54.0	-7.8	1.81 V	157	32.90	13.30

REMARKS:

1. Emission Level(dBuV/m) = Raw Value(dBuV) + Correction Factor(dB/m)
2. Correction Factor(dB/m) = Antenna Factor(dB/m) + Cable Factor(dB)
3. The other emission levels were very low against the limit.
4. Margin value = Emission Level – Limit value
5. " * ": Fundamental frequency.

CHANNEL	TX Channel 11	DETECTOR FUNCTION	Peak (PK)
FREQUENCY RANGE	1GHz ~ 25GHz		Average (AV)

ANTENNA POLARITY & TEST DISTANCE: HORIZONTAL AT 3 M

NO.	FREQ. (MHz)	EMISSION LEVEL (dBuV/m)	LIMIT (dBuV/m)	MARGIN (dB)	ANTENNA HEIGHT (m)	TABLE ANGLE (Degree)	RAW VALUE (dBuV)	CORRECTION FACTOR (dB/m)
1	*2462.00	102.8 PK			1.31 H	331	69.90	32.90
2	*2462.00	93.0 AV			1.31 H	331	60.10	32.90
3	2483.50	65.0 PK	74.0	-9.0	1.70 H	331	32.00	33.00
4	2483.50	50.2 AV	54.0	-3.8	1.70 H	331	17.20	33.00
5	4924.00	47.8 PK	74.0	-26.2	2.31 H	222	41.80	6.00
6	4924.00	34.7 AV	54.0	-19.3	2.31 H	222	28.70	6.00

ANTENNA POLARITY & TEST DISTANCE: VERTICAL AT 3 M

NO.	FREQ. (MHz)	EMISSION LEVEL (dBuV/m)	LIMIT (dBuV/m)	MARGIN (dB)	ANTENNA HEIGHT (m)	TABLE ANGLE (Degree)	RAW VALUE (dBuV)	CORRECTION FACTOR (dB/m)
1	*2462.00	105.2 PK			1.24 V	346	72.30	32.90
2	*2462.00	95.1 AV			1.24 V	346	62.20	32.90
3	2483.50	66.5 PK	74.0	-7.5	1.17 V	351	33.50	33.00
4	2483.50	52.5 AV	54.0	-1.5	1.17 V	351	19.50	33.00
5	4924.00	48.7 PK	74.0	-25.3	1.54 V	28	42.70	6.00
6	4924.00	35.2 AV	54.0	-18.8	1.54 V	28	29.20	6.00

REMARKS:

1. Emission Level(dBuV/m) = Raw Value(dBuV) + Correction Factor(dB/m)
2. Correction Factor(dB/m) = Antenna Factor(dB/m) + Cable Factor(dB)
3. The other emission levels were very low against the limit.
4. Margin value = Emission Level – Limit value
5. " * " : Fundamental frequency.

802.11n (HT40)

CHANNEL	TX Channel 3	DETECTOR FUNCTION	Peak (PK)
FREQUENCY RANGE	1GHz ~ 25GHz		Average (AV)

ANTENNA POLARITY & TEST DISTANCE: HORIZONTAL AT 3 M								
NO.	FREQ. (MHz)	EMISSION LEVEL (dBuV/m)	LIMIT (dBuV/m)	MARGIN (dB)	ANTENNA HEIGHT (m)	TABLE ANGLE (Degree)	RAW VALUE (dBuV)	CORRECTION FACTOR (dB/m)
1	2390.00	62.7 PK	74.0	-11.3	1.66 H	327	29.90	32.80
2	2390.00	50.0 AV	54.0	-4.0	1.66 H	327	17.20	32.80
3	*2422.00	95.4 PK			1.37 H	326	62.50	32.90
4	*2422.00	85.5 AV			1.37 H	326	52.60	32.90
5	4844.00	46.9 PK	74.0	-27.1	1.48 H	301	41.10	5.80
6	4844.00	34.1 AV	54.0	-19.9	1.48 H	301	28.30	5.80
ANTENNA POLARITY & TEST DISTANCE: VERTICAL AT 3 M								
NO.	FREQ. (MHz)	EMISSION LEVEL (dBuV/m)	LIMIT (dBuV/m)	MARGIN (dB)	ANTENNA HEIGHT (m)	TABLE ANGLE (Degree)	RAW VALUE (dBuV)	CORRECTION FACTOR (dB/m)
1	2390.00	66.0 PK	74.0	-8.0	1.04 V	350	33.20	32.80
2	2390.00	52.6 AV	54.0	-1.4	1.04 V	350	19.80	32.80
3	*2422.00	99.4 PK			1.07 V	345	66.50	32.90
4	*2422.00	88.8 AV			1.07 V	345	55.90	32.90
5	4844.00	47.1 PK	74.0	-26.9	1.60 V	231	41.30	5.80
6	4844.00	34.3 AV	54.0	-19.7	1.60 V	231	28.50	5.80

REMARKS:

1. Emission Level(dBuV/m) = Raw Value(dBuV) + Correction Factor(dB/m)
2. Correction Factor(dB/m) = Antenna Factor(dB/m) + Cable Factor(dB)
3. The other emission levels were very low against the limit.
4. Margin value = Emission Level – Limit value
5. " * " : Fundamental frequency.

CHANNEL	TX Channel 6	DETECTOR FUNCTION	Peak (PK)
FREQUENCY RANGE	1GHz ~ 25GHz		Average (AV)

ANTENNA POLARITY & TEST DISTANCE: HORIZONTAL AT 3 M

NO.	FREQ. (MHz)	EMISSION LEVEL (dBuV/m)	LIMIT (dBuV/m)	MARGIN (dB)	ANTENNA HEIGHT (m)	TABLE ANGLE (Degree)	RAW VALUE (dBuV)	CORRECTION FACTOR (dB/m)
1	2390.00	59.1 PK	74.0	-14.9	1.83 H	318	26.30	32.80
2	2390.00	47.3 AV	54.0	-6.7	1.83 H	318	14.50	32.80
3	*2437.00	101.5 PK			1.36 H	326	68.60	32.90
4	*2437.00	91.8 AV			1.36 H	326	58.90	32.90
5	2483.50	63.5 PK	74.0	-10.5	1.53 H	334	30.50	33.00
6	2483.50	50.9 AV	54.0	-3.1	1.53 H	334	17.90	33.00
7	4874.00	47.7 PK	74.0	-26.3	2.01 H	177	41.70	6.00
8	4874.00	34.5 AV	54.0	-19.5	2.01 H	177	28.50	6.00

ANTENNA POLARITY & TEST DISTANCE: VERTICAL AT 3 M

NO.	FREQ. (MHz)	EMISSION LEVEL (dBuV/m)	LIMIT (dBuV/m)	MARGIN (dB)	ANTENNA HEIGHT (m)	TABLE ANGLE (Degree)	RAW VALUE (dBuV)	CORRECTION FACTOR (dB/m)
1	2390.00	63.6 PK	74.0	-10.4	1.00 V	345	30.80	32.80
2	2390.00	50.5 AV	54.0	-3.5	1.00 V	345	17.70	32.80
3	*2437.00	104.0 PK			1.00 V	353	71.10	32.90
4	*2437.00	93.9 AV			1.00 V	353	61.00	32.90
5	2483.50	65.4 PK	74.0	-8.6	1.17 V	354	32.40	33.00
6	2483.50	52.9 AV	54.0	-1.1	1.17 V	354	19.90	33.00
7	4874.00	47.5 PK	74.0	-26.5	1.39 V	140	41.50	6.00
8	4874.00	35.6 AV	54.0	-18.4	1.39 V	140	29.60	6.00

REMARKS:

1. Emission Level(dBuV/m) = Raw Value(dBuV) + Correction Factor(dB/m)
2. Correction Factor(dB/m) = Antenna Factor(dB/m) + Cable Factor(dB)
3. The other emission levels were very low against the limit.
4. Margin value = Emission Level – Limit value
5. " * ": Fundamental frequency.

CHANNEL	TX Channel 9	DETECTOR FUNCTION	Peak (PK)
FREQUENCY RANGE	1GHz ~ 25GHz		Average (AV)

ANTENNA POLARITY & TEST DISTANCE: HORIZONTAL AT 3 M

NO.	FREQ. (MHz)	EMISSION LEVEL (dBuV/m)	LIMIT (dBuV/m)	MARGIN (dB)	ANTENNA HEIGHT (m)	TABLE ANGLE (Degree)	RAW VALUE (dBuV)	CORRECTION FACTOR (dB/m)
1	*2452.00	95.5 PK			1.33 H	328	62.50	33.00
2	*2452.00	85.8 AV			1.33 H	328	52.80	33.00
3	2483.50	63.2 PK	74.0	-10.8	1.55 H	336	30.20	33.00
4	2483.50	51.5 AV	54.0	-2.5	1.55 H	336	18.50	33.00
5	4904.00	47.1 PK	74.0	-26.9	1.74 H	145	41.20	5.90
6	4904.00	34.4 AV	54.0	-19.6	1.74 H	145	28.50	5.90

ANTENNA POLARITY & TEST DISTANCE: VERTICAL AT 3 M

NO.	FREQ. (MHz)	EMISSION LEVEL (dBuV/m)	LIMIT (dBuV/m)	MARGIN (dB)	ANTENNA HEIGHT (m)	TABLE ANGLE (Degree)	RAW VALUE (dBuV)	CORRECTION FACTOR (dB/m)
1	*2452.00	97.9 PK			1.00 V	354	64.90	33.00
2	*2452.00	88.3 AV			1.00 V	354	55.30	33.00
3	2483.50	63.6 PK	74.0	-10.4	1.17 V	356	30.60	33.00
4	2483.50	52.6 AV	54.0	-1.4	1.17 V	356	19.60	33.00
5	4904.00	47.3 PK	74.0	-26.7	1.68 V	265	41.40	5.90
6	4904.00	35.2 AV	54.0	-18.8	1.68 V	265	29.30	5.90

REMARKS:

1. Emission Level(dBuV/m) = Raw Value(dBuV) + Correction Factor(dB/m)
2. Correction Factor(dB/m) = Antenna Factor(dB/m) + Cable Factor(dB)
3. The other emission levels were very low against the limit.
4. Margin value = Emission Level – Limit value
5. " * " : Fundamental frequency.

Below 1GHz worst-case data:

Radio 1: CDD Mode

802.11b

CHANNEL	TX Channel 1	DETECTOR FUNCTION	Quasi-Peak (QP)
FREQUENCY RANGE	30MHz ~ 1GHz		
TEST MODE	A		

ANTENNA POLARITY & TEST DISTANCE: HORIZONTAL AT 3 M

NO.	FREQ. (MHz)	EMISSION LEVEL (dBuV/m)	LIMIT (dBuV/m)	MARGIN (dB)	ANTENNA HEIGHT (m)	TABLE ANGLE (Degree)	RAW VALUE (dBuV)	CORRECTION FACTOR (dB/m)
1	57.12	30.3 QP	40.0	-9.7	1.99 H	66	44.90	-14.60
2	154.33	30.0 QP	43.5	-13.5	1.99 H	249	43.70	-13.70
3	389.59	43.2 QP	46.0	-2.8	1.00 H	115	53.40	-10.20
4	624.85	39.1 QP	46.0	-6.9	1.00 H	137	43.80	-4.70
5	751.23	42.4 QP	46.0	-3.6	1.00 H	312	44.60	-2.20
6	875.67	41.3 QP	46.0	-4.7	1.49 H	6	41.40	-0.10

ANTENNA POLARITY & TEST DISTANCE: VERTICAL AT 3 M

NO.	FREQ. (MHz)	EMISSION LEVEL (dBuV/m)	LIMIT (dBuV/m)	MARGIN (dB)	ANTENNA HEIGHT (m)	TABLE ANGLE (Degree)	RAW VALUE (dBuV)	CORRECTION FACTOR (dB/m)
1	61.01	30.7 QP	40.0	-9.3	1.49 V	11	45.70	-15.00
2	212.66	30.8 QP	43.5	-12.7	1.00 V	37	46.90	-16.10
3	389.76	44.3 QP	46.0	-1.7	1.49 V	303	54.50	-10.20
4	624.85	42.2 QP	46.0	-3.8	1.49 V	153	46.90	-4.70
5	751.23	38.6 QP	46.0	-7.4	1.49 V	295	40.80	-2.20
6	875.67	36.7 QP	46.0	-9.3	1.00 V	111	36.80	-0.10

Remarks:

1. Emission Level(dBuV/m) = Raw Value(dBuV) + Correction Factor(dB/m)
2. Correction Factor(dB/m) = Antenna Factor(dB/m) + Cable Factor(dB)
3. The other emission levels were very low against the limit.
4. Margin value = Emission Level – Limit value

CHANNEL	TX Channel 1	DETECTOR FUNCTION	Quasi-Peak (QP)
FREQUENCY RANGE	30MHz ~ 1GHz		
TEST MODE	B		

ANTENNA POLARITY & TEST DISTANCE: HORIZONTAL AT 3 M

NO.	FREQ. (MHz)	EMISSION LEVEL (dBuV/m)	LIMIT (dBuV/m)	MARGIN (dB)	ANTENNA HEIGHT (m)	TABLE ANGLE (Degree)	RAW VALUE (dBuV)	CORRECTION FACTOR (dB/m)
1	37.68	30.4 QP	40.0	-9.6	1.50 H	91	45.70	-15.30
2	156.28	30.2 QP	43.5	-13.3	1.50 H	252	44.00	-13.80
3	389.59	41.4 QP	46.0	-4.6	2.00 H	17	51.60	-10.20
4	624.85	39.3 QP	46.0	-6.7	1.00 H	135	44.00	-4.70
5	751.23	41.9 QP	46.0	-4.1	1.00 H	318	44.10	-2.20
6	875.67	41.5 QP	46.0	-4.5	1.50 H	8	41.60	-0.10

ANTENNA POLARITY & TEST DISTANCE: VERTICAL AT 3 M

NO.	FREQ. (MHz)	EMISSION LEVEL (dBuV/m)	LIMIT (dBuV/m)	MARGIN (dB)	ANTENNA HEIGHT (m)	TABLE ANGLE (Degree)	RAW VALUE (dBuV)	CORRECTION FACTOR (dB/m)
1	40.50	38.6 QP	40.0	-1.4	1.48 V	238	53.80	-15.20
2	125.17	27.3 QP	43.5	-16.2	1.00 V	240	43.40	-16.10
3	389.59	43.4 QP	46.0	-2.6	1.49 V	138	53.60	-10.20
4	624.85	41.3 QP	46.0	-4.7	1.49 V	156	46.00	-4.70
5	751.23	37.9 QP	46.0	-8.1	1.49 V	246	40.10	-2.20
6	875.67	37.2 QP	46.0	-8.8	1.00 V	235	37.30	-0.10

Remarks:

1. Emission Level(dBuV/m) = Raw Value(dBuV) + Correction Factor(dB/m)
2. Correction Factor(dB/m) = Antenna Factor(dB/m) + Cable Factor(dB)
3. The other emission levels were very low against the limit.
4. Margin value = Emission Level – Limit value

Radio 3: CDD Mode

802.11b

CHANNEL	TX Channel 1	DETECTOR FUNCTION	Quasi-Peak (QP)
FREQUENCY RANGE	30MHz ~ 1GHz		
TEST MODE	A		

ANTENNA POLARITY & TEST DISTANCE: HORIZONTAL AT 3 M

NO.	FREQ. (MHz)	EMISSION LEVEL (dBuV/m)	LIMIT (dBuV/m)	MARGIN (dB)	ANTENNA HEIGHT (m)	TABLE ANGLE (Degree)	RAW VALUE (dBuV)	CORRECTION FACTOR (dB/m)
1	57.12	30.1 QP	40.0	-9.9	2.00 H	168	44.70	-14.60
2	249.60	30.2 QP	46.0	-15.8	1.51 H	252	44.20	-14.00
3	389.59	39.3 QP	46.0	-6.7	2.00 H	140	49.50	-10.20
4	624.85	41.3 QP	46.0	-4.7	1.51 H	152	46.00	-4.70
5	751.23	40.9 QP	46.0	-5.1	1.01 H	336	43.10	-2.20
6	875.67	42.3 QP	46.0	-3.7	1.51 H	11	42.40	-0.10

ANTENNA POLARITY & TEST DISTANCE: VERTICAL AT 3 M

NO.	FREQ. (MHz)	EMISSION LEVEL (dBuV/m)	LIMIT (dBuV/m)	MARGIN (dB)	ANTENNA HEIGHT (m)	TABLE ANGLE (Degree)	RAW VALUE (dBuV)	CORRECTION FACTOR (dB/m)
1	29.90	36.5 QP	40.0	-3.5	1.00 V	133	52.80	-16.30
2	249.60	28.2 QP	46.0	-17.8	1.50 V	189	42.20	-14.00
3	391.54	40.1 QP	46.0	-5.9	1.50 V	307	50.20	-10.10
4	500.42	36.6 QP	46.0	-9.4	1.00 V	179	44.50	-7.90
5	624.85	42.5 QP	46.0	-3.5	1.00 V	9	47.20	-4.70
6	751.23	36.2 QP	46.0	-9.8	1.50 V	170	38.40	-2.20

Remarks:

1. Emission Level(dBuV/m) = Raw Value(dBuV) + Correction Factor(dB/m)
2. Correction Factor(dB/m) = Antenna Factor(dB/m) + Cable Factor(dB)
3. The other emission levels were very low against the limit.
4. Margin value = Emission Level – Limit value

CHANNEL	TX Channel 1	DETECTOR FUNCTION	Quasi-Peak (QP)
FREQUENCY RANGE	30MHz ~ 1GHz		
TEST MODE	B		

ANTENNA POLARITY & TEST DISTANCE: HORIZONTAL AT 3 M

NO.	FREQ. (MHz)	EMISSION LEVEL (dBuV/m)	LIMIT (dBuV/m)	MARGIN (dB)	ANTENNA HEIGHT (m)	TABLE ANGLE (Degree)	RAW VALUE (dBuV)	CORRECTION FACTOR (dB/m)
1	125.17	32.8 QP	43.5	-10.7	2.00 H	255	48.90	-16.10
2	389.59	37.1 QP	46.0	-8.9	2.00 H	13	47.30	-10.20
3	500.42	31.3 QP	46.0	-14.7	1.51 H	133	39.20	-7.90
4	624.85	38.6 QP	46.0	-7.4	1.51 H	144	43.30	-4.70
5	751.23	41.0 QP	46.0	-5.0	1.01 H	337	43.20	-2.20
6	875.67	41.2 QP	46.0	-4.8	1.51 H	27	41.30	-0.10

ANTENNA POLARITY & TEST DISTANCE: VERTICAL AT 3 M

NO.	FREQ. (MHz)	EMISSION LEVEL (dBuV/m)	LIMIT (dBuV/m)	MARGIN (dB)	ANTENNA HEIGHT (m)	TABLE ANGLE (Degree)	RAW VALUE (dBuV)	CORRECTION FACTOR (dB/m)
1	40.47	36.7 QP	40.0	-3.3	2.00 V	180	51.90	-15.20
2	125.17	29.8 QP	43.5	-13.7	1.00 V	256	45.90	-16.10
3	389.59	40.1 QP	46.0	-5.9	1.50 V	138	50.30	-10.20
4	500.42	36.6 QP	46.0	-9.4	1.00 V	166	44.50	-7.90
5	624.85	40.3 QP	46.0	-5.7	1.50 V	160	45.00	-4.70
6	751.23	37.8 QP	46.0	-8.2	1.99 V	204	40.00	-2.20

Remarks:

1. Emission Level(dBuV/m) = Raw Value(dBuV) + Correction Factor(dB/m)
2. Correction Factor(dB/m) = Antenna Factor(dB/m) + Cable Factor(dB)
3. The other emission levels were very low against the limit.
4. Margin value = Emission Level – Limit value

4.2 Conducted Emission Measurement

4.2.1 Limits of Conducted Emission Measurement

Frequency (MHz)	Conducted Limit (dBuV)	
	Quasi-peak	Average
0.15 - 0.5	66 - 56	56 - 46
0.50 - 5.0	56	46
5.0 - 30.0	60	50

- Note:** 1. The lower limit shall apply at the transition frequencies.
 2. The limit decreases in line with the logarithm of the frequency in the range of 0.15 to 0.50MHz.

4.2.2 Test Instruments

Description & Manufacturer	Model No.	Serial No.	Cal. Date	Cal. Due
Test Receiver ROHDE & SCHWARZ	ESCI	100613	Nov. 16, 2015	Nov. 15, 2016
RF signal cable (with 10dB PAD) Woken	5D-FB	Cable-cond1-01	Dec. 26, 2015	Dec. 25, 2016
LISN/AMN ROHDE & SCHWARZ (EUT)	ESH3-Z5	835239/001	Feb. 26, 2016	Feb. 25, 2017
LISN/AMN ROHDE & SCHWARZ (Peripheral)	ESH3-Z5	100220	Nov. 13, 2015	Nov. 12, 2016
Software ADT	BV ADT_Cond_ V7.3.7.3	NA	NA	NA

- Note:** 1. The calibration interval of the above test instruments is 12 months and the calibrations are traceable to NML/ROC and NIST/USA.
 2. The test was performed in HwaYa Shielded Room 1.
 3. The VCCI Site Registration No. is C-2040.

4.2.3 Test Procedures

- a. The EUT was placed 0.4 meters from the conducting wall of the shielded room with EUT being connected to the power mains through a line impedance stabilization network (LISN). Other support units were connected to the power mains through another LISN. The two LISNs provide 50 ohm/ 50uH of coupling impedance for the measuring instrument.
- b. Both lines of the power mains connected to the EUT were checked for maximum conducted interference.
- c. The frequency range from 150kHz to 30MHz was searched. Emission levels under (Limit - 20dB) was not recorded.

Note: The resolution bandwidth and video bandwidth of test receiver is 9kHz for quasi-peak detection (QP) and average detection (AV) at frequency 0.15MHz-30MHz.

4.2.4 Deviation from Test Standard

No deviation.

4.2.5 Test Setup

4.2.7 Test Results

Radio 1: CDD Mode

Phase	Line (L)	Detector Function	Quasi-Peak (QP) / Average (AV)
Test Mode	A		

No	Freq. [MHz]	Corr. Factor (dB)	Reading Value		Emission Level		Limit		Margin	
			[dB (uV)]		[dB (uV)]		[dB (uV)]		(dB)	
			Q.P.	AV.	Q.P.	AV.	Q.P.	AV.	Q.P.	AV.
1	0.15400	10.08	38.81	20.74	48.89	30.82	65.78	55.78	-16.89	-24.96
2	0.20200	10.08	34.65	17.78	44.73	27.86	63.53	53.53	-18.80	-25.67
3	0.22985	10.09	31.17	14.83	41.26	24.92	62.46	52.46	-21.20	-27.54
4	0.27400	10.11	27.46	13.31	37.57	23.42	61.00	51.00	-23.43	-27.58
5	0.62200	10.21	26.25	18.08	36.46	28.29	56.00	46.00	-19.54	-17.71
6	23.13000	11.62	16.87	14.53	28.49	26.15	60.00	50.00	-31.51	-23.85

Remarks:

1. Q.P. and AV. are abbreviations of quasi-peak and average individually.
2. The emission levels of other frequencies were very low against the limit.
3. Margin value = Emission level - Limit value
4. Correction factor = Insertion loss + Cable loss
5. Emission Level = Correction Factor + Reading Value.

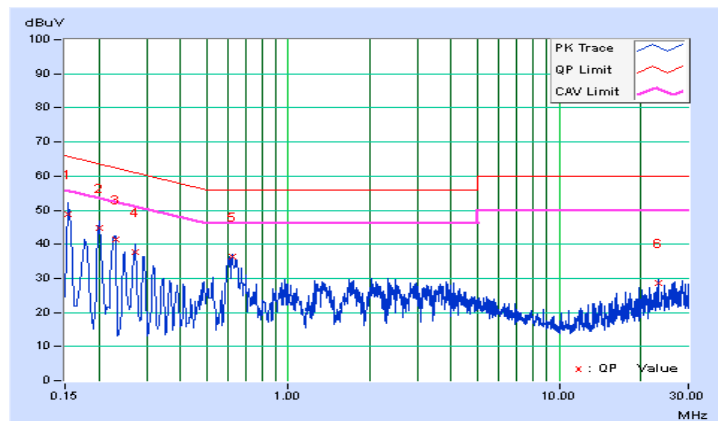

Phase	Neutral (N)	Detector Function	Quasi-Peak (QP) / Average (AV)
Test Mode	A		

No	Freq. [MHz]	Corr. Factor (dB)	Reading Value [dB (uV)]		Emission Level [dB (uV)]		Limit [dB (uV)]		Margin (dB)	
			Q.P.	AV.	Q.P.	AV.	Q.P.	AV.	Q.P.	AV.
			1	0.15000	10.08	42.08	23.33	52.16	33.41	66.00
2	0.16977	10.08	38.71	21.83	48.79	31.91	64.97	54.97	-16.18	-23.06
3	0.19780	10.08	35.33	18.38	45.41	28.46	63.70	53.70	-18.29	-25.24
4	0.29400	10.16	25.43	11.96	35.59	22.12	60.41	50.41	-24.82	-28.29
5	0.64220	10.26	25.20	16.38	35.46	26.64	56.00	46.00	-20.54	-19.36
6	23.13000	11.79	16.84	14.55	28.63	26.34	60.00	50.00	-31.37	-23.66

Remarks:

1. Q.P. and AV. are abbreviations of quasi-peak and average individually.
2. The emission levels of other frequencies were very low against the limit.
3. Margin value = Emission level - Limit value
4. Correction factor = Insertion loss + Cable loss
5. Emission Level = Correction Factor + Reading Value.

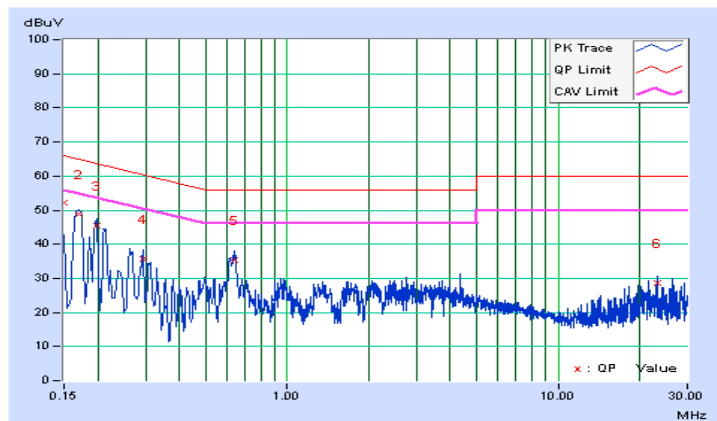

Phase	Line (L)	Detector Function	Quasi-Peak (QP) / Average (AV)
Test Mode	B		

No	Freq. [MHz]	Corr. Factor (dB)	Reading Value [dB (uV)]		Emission Level [dB (uV)]		Limit [dB (uV)]		Margin (dB)	
			Q.P.	AV.	Q.P.	AV.	Q.P.	AV.	Q.P.	AV.
			1	0.15000	10.07	36.45	22.82	46.52	32.89	66.00
2	0.16200	10.08	34.19	19.74	44.27	29.82	65.36	55.36	-21.09	-25.54
3	0.50132	10.19	21.76	16.34	31.95	26.53	56.00	46.00	-24.05	-19.47
4	2.19400	10.38	18.62	14.03	29.00	24.41	56.00	46.00	-27.00	-21.59
5	10.02200	10.77	16.67	11.48	27.44	22.25	60.00	50.00	-32.56	-27.75
6	24.73000	11.72	25.93	10.85	37.65	22.57	60.00	50.00	-22.35	-27.43

Remarks:

1. Q.P. and AV. are abbreviations of quasi-peak and average individually.
2. The emission levels of other frequencies were very low against the limit.
3. Margin value = Emission level - Limit value
4. Correction factor = Insertion loss + Cable loss
5. Emission Level = Correction Factor + Reading Value.

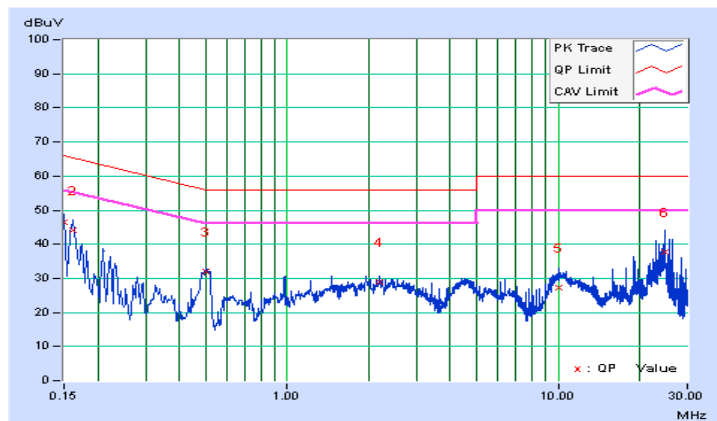

Phase	Neutral (N)	Detector Function	Quasi-Peak (QP) / Average (AV)
Test Mode	B		

No	Freq. [MHz]	Corr. Factor (dB)	Reading Value [dB (uV)]		Emission Level [dB (uV)]		Limit [dB (uV)]		Margin (dB)	
			Q.P.	AV.	Q.P.	AV.	Q.P.	AV.	Q.P.	AV.
			1	0.15400	10.08	35.47	21.18	45.55	31.26	65.78
2	0.17400	10.08	32.01	17.16	42.09	27.24	64.77	54.77	-22.68	-27.53
3	0.20600	10.08	26.52	11.96	36.60	22.04	63.37	53.37	-26.77	-31.33
4	0.51000	10.25	18.31	13.65	28.56	23.90	56.00	46.00	-27.44	-22.10
5	9.87800	10.84	20.45	15.41	31.29	26.25	60.00	50.00	-28.71	-23.75
6	23.33000	11.81	26.53	11.49	38.34	23.30	60.00	50.00	-21.66	-26.70

Remarks:

1. Q.P. and AV. are abbreviations of quasi-peak and average individually.
2. The emission levels of other frequencies were very low against the limit.
3. Margin value = Emission level - Limit value
4. Correction factor = Insertion loss + Cable loss
5. Emission Level = Correction Factor + Reading Value.

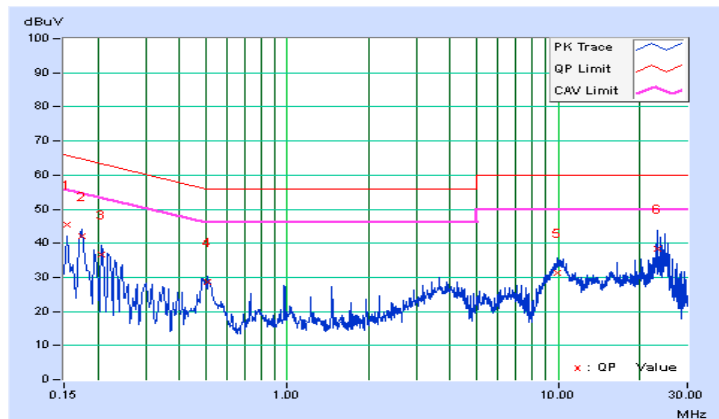

Radio 3: CDD Mode

Phase	Line (L)	Detector Function	Quasi-Peak (QP) / Average (AV)
Test Mode	A		

No	Freq. [MHz]	Corr. Factor (dB)	Reading Value		Emission Level		Limit		Margin	
			[dB (uV)]		[dB (uV)]		[dB (uV)]		(dB)	
			Q.P.	AV.	Q.P.	AV.	Q.P.	AV.	Q.P.	AV.
1	0.15400	10.08	38.29	19.96	48.37	30.04	65.78	55.78	-17.41	-25.74
2	0.17000	10.08	38.36	21.29	48.44	31.37	64.96	54.96	-16.52	-23.59
3	0.22600	10.09	31.94	15.81	42.03	25.90	62.60	52.60	-20.57	-26.70
4	0.26639	10.11	27.43	11.65	37.54	21.76	61.23	51.23	-23.69	-29.47
5	0.63400	10.22	25.35	17.14	35.57	27.36	56.00	46.00	-20.43	-18.64
6	23.12600	11.62	15.53	12.77	27.15	24.39	60.00	50.00	-32.85	-25.61

Remarks:

1. Q.P. and AV. are abbreviations of quasi-peak and average individually.
2. The emission levels of other frequencies were very low against the limit.
3. Margin value = Emission level - Limit value
4. Correction factor = Insertion loss + Cable loss
5. Emission Level = Correction Factor + Reading Value.

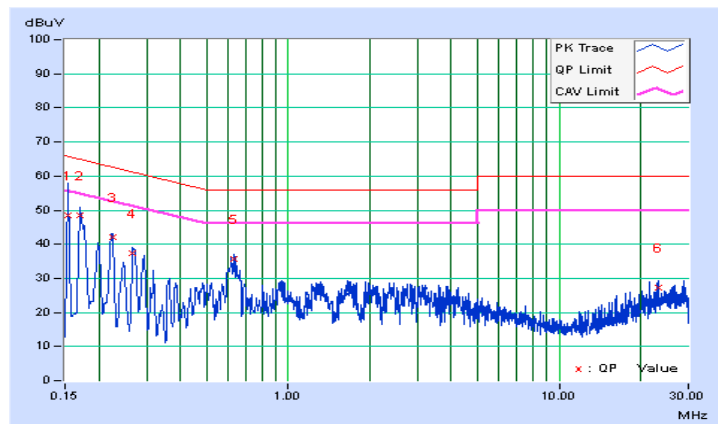

Phase	Neutral (N)	Detector Function	Quasi-Peak (QP) / Average (AV)
Test Mode	A		

No	Freq. [MHz]	Corr. Factor (dB)	Reading Value [dB (uV)]		Emission Level [dB (uV)]		Limit [dB (uV)]		Margin (dB)	
			Q.P.	AV.	Q.P.	AV.	Q.P.	AV.	Q.P.	AV.
			1	0.15728	10.08	39.84	20.33	49.92	30.41	65.61
2	0.20201	10.08	34.43	18.02	44.51	28.10	63.53	53.53	-19.02	-25.43
3	0.24614	10.12	30.40	15.51	40.52	25.63	61.89	51.89	-21.37	-26.26
4	0.30071	10.16	24.85	10.46	35.01	20.62	60.22	50.22	-25.21	-29.60
5	0.63000	10.26	26.77	18.87	37.03	29.13	56.00	46.00	-18.97	-16.87
6	26.61000	12.04	15.42	12.86	27.46	24.90	60.00	50.00	-32.54	-25.10

Remarks:

1. Q.P. and AV. are abbreviations of quasi-peak and average individually.
2. The emission levels of other frequencies were very low against the limit.
3. Margin value = Emission level - Limit value
4. Correction factor = Insertion loss + Cable loss
5. Emission Level = Correction Factor + Reading Value.

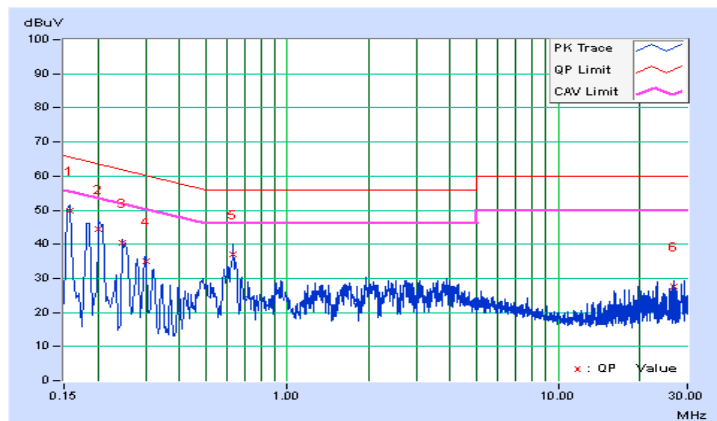

Phase	Line (L)	Detector Function	Quasi-Peak (QP) / Average (AV)
Test Mode	B		

No	Freq. [MHz]	Corr. Factor (dB)	Reading Value [dB (uV)]		Emission Level [dB (uV)]		Limit [dB (uV)]		Margin (dB)	
			Q.P.	AV.	Q.P.	AV.	Q.P.	AV.	Q.P.	AV.
			1	0.16977	10.08	32.99	18.50	43.07	28.58	64.97
2	0.19367	10.08	28.74	15.13	38.82	25.21	63.88	53.88	-25.06	-28.67
3	0.49400	10.19	20.70	15.26	30.89	25.45	56.10	46.10	-25.21	-20.65
4	1.95000	10.37	18.68	14.36	29.05	24.73	56.00	46.00	-26.95	-21.27
5	10.23400	10.78	17.01	11.87	27.79	22.65	60.00	50.00	-32.21	-27.35
6	23.32600	11.63	28.33	13.38	39.96	25.01	60.00	50.00	-20.04	-24.99

Remarks:

1. Q.P. and AV. are abbreviations of quasi-peak and average individually.
2. The emission levels of other frequencies were very low against the limit.
3. Margin value = Emission level - Limit value
4. Correction factor = Insertion loss + Cable loss
5. Emission Level = Correction Factor + Reading Value.

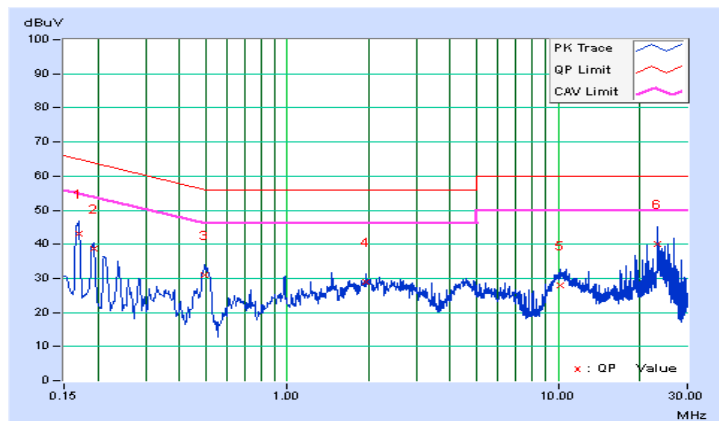

Phase	Neutral (N)	Detector Function	Quasi-Peak (QP) / Average (AV)
Test Mode	B		

No	Freq. [MHz]	Corr. Factor (dB)	Reading Value [dB (uV)]		Emission Level [dB (uV)]		Limit [dB (uV)]		Margin (dB)	
			Q.P.	AV.	Q.P.	AV.	Q.P.	AV.	Q.P.	AV.
			1	0.15400	10.08	36.14	21.90	46.22	31.98	65.78
2	0.17801	10.08	31.99	17.16	42.07	27.24	64.58	54.58	-22.51	-27.34
3	0.49400	10.25	16.47	10.59	26.72	20.84	56.10	46.10	-29.38	-25.26
4	3.90600	10.58	16.05	11.53	26.63	22.11	56.00	46.00	-29.37	-23.89
5	10.20200	10.86	20.83	15.78	31.69	26.64	60.00	50.00	-28.31	-23.36
6	25.37000	11.95	25.66	20.36	37.61	32.31	60.00	50.00	-22.39	-17.69

Remarks:

1. Q.P. and AV. are abbreviations of quasi-peak and average individually.
2. The emission levels of other frequencies were very low against the limit.
3. Margin value = Emission level - Limit value
4. Correction factor = Insertion loss + Cable loss
5. Emission Level = Correction Factor + Reading Value.

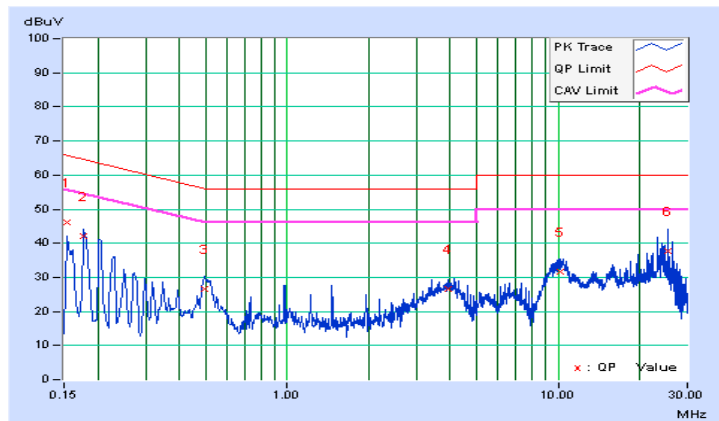

4.3 6dB Bandwidth Measurement

4.3.1 Limits of 6dB Bandwidth Measurement

The minimum of 6dB Bandwidth Measurement is 0.5 MHz.

4.3.2 Test Setup

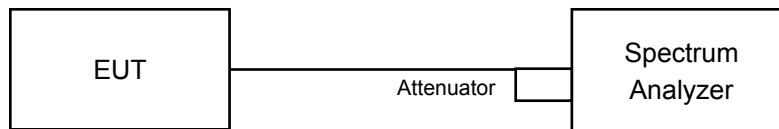

4.3.3 Test Instruments

Refer to section 4.1.2 to get information of above instrument.

4.3.4 Test Procedure

- Set resolution bandwidth (RBW) = 100kHz
- Set the video bandwidth (VBW) $\geq 3 \times$ RBW, Detector = peak.
- Trace mode = max hold.
- Sweep = auto couple.
- Measure the maximum width of the emission that is constrained by the frequencies associated with the two amplitude points (upper and lower) that are attenuated by 6 dB relative to the maximum level measured in the fundamental emission

4.3.5 Deviation from Test Standard

No deviation.

4.3.6 EUT Operating Conditions

The software provided by client to enable the EUT under transmission condition continuously at lowest, middle and highest channel frequencies individually.

4.3.7 Test Result

Radio1: CDD Mode

802.11b

Channel	Frequency (MHz)	6dB Bandwidth (MHz)		Minimum Limit (MHz)	Pass / Fail
		Chain 0	Chain 1		
1	2412	8.10	8.10	0.5	Pass
6	2437	8.07	8.10	0.5	Pass
11	2462	8.11	8.11	0.5	Pass

802.11g

Channel	Frequency (MHz)	6dB Bandwidth (MHz)		Minimum Limit (MHz)	Pass / Fail
		Chain 0	Chain 1		
1	2412	16.39	16.40	0.5	Pass
6	2437	16.37	16.38	0.5	Pass
11	2462	16.39	16.40	0.5	Pass

802.11n (HT20)

Channel	Frequency (MHz)	6dB Bandwidth (MHz)		Minimum Limit (MHz)	Pass / Fail
		Chain 0	Chain 1		
1	2412	17.62	17.62	0.5	Pass
6	2437	17.60	17.61	0.5	Pass
11	2462	17.61	17.61	0.5	Pass

802.11n (HT40)

Channel	Frequency (MHz)	6dB Bandwidth (MHz)		Minimum Limit (MHz)	Pass / Fail
		Chain 0	Chain 1		
3	2422	35.29	35.24	0.5	Pass
6	2437	35.23	35.20	0.5	Pass
9	2452	35.26	35.22	0.5	Pass

Spectrum Plot of Worst Value

802.11b

802.11g

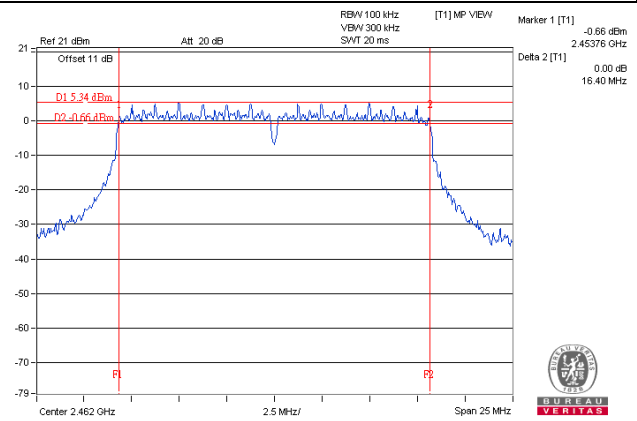
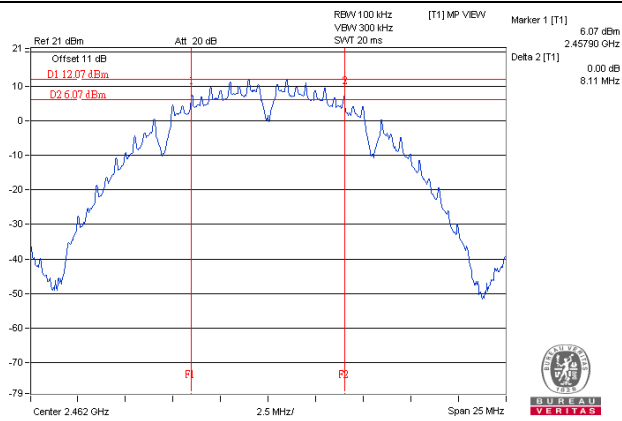

802.11n (HT20)

802.11n (HT40)

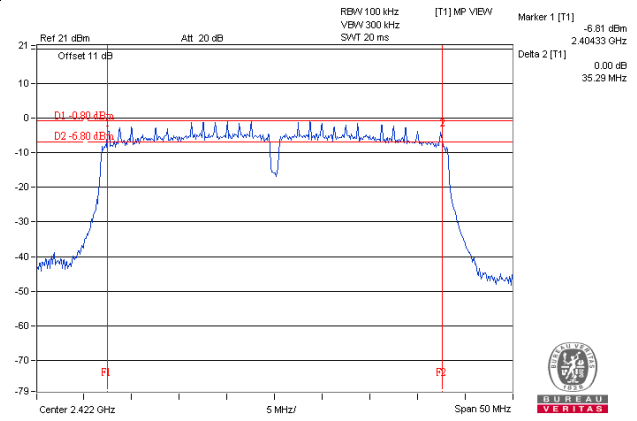
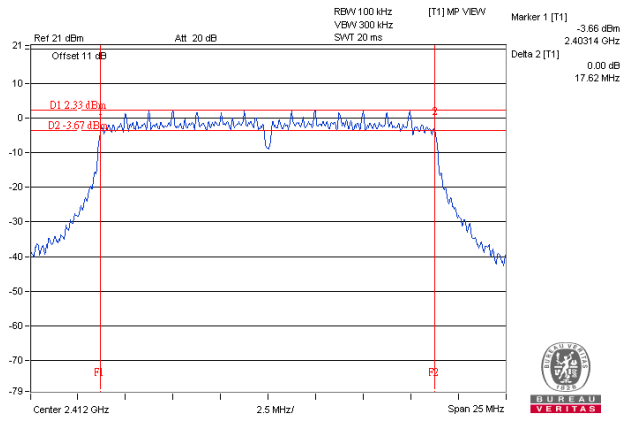

Radio1: Beamforming Mode

802.11n (HT20)

Channel	Frequency (MHz)	6dB Bandwidth (MHz)		Minimum Limit (MHz)	Pass / Fail
		Chain 0	Chain 1		
1	2412	17.63	17.64	0.5	Pass
6	2437	17.60	17.61	0.5	Pass
11	2462	17.62	17.60	0.5	Pass

802.11n (HT40)

Channel	Frequency (MHz)	6dB Bandwidth (MHz)		Minimum Limit (MHz)	Pass / Fail
		Chain 0	Chain 1		
3	2422	35.21	35.24	0.5	Pass
6	2437	35.19	35.21	0.5	Pass
9	2452	35.30	35.25	0.5	Pass

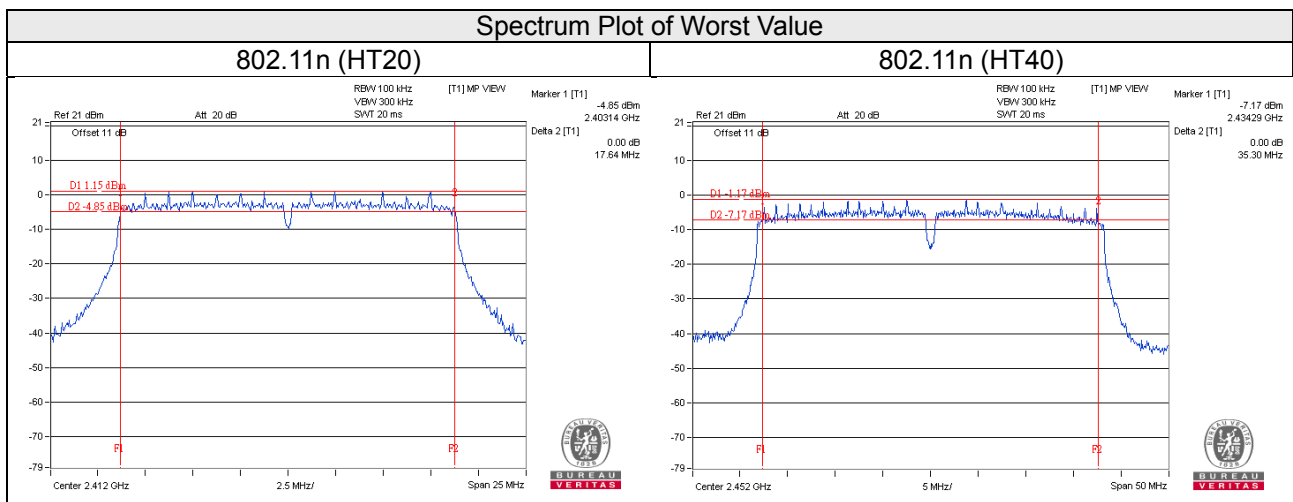

Radio3: CDD Mode

802.11b

Channel	Frequency (MHz)	6dB Bandwidth (MHz)	Minimum Limit (MHz)	Pass / Fail
1	2412	7.08	0.5	Pass
6	2437	6.15	0.5	Pass
11	2462	6.15	0.5	Pass

802.11g

Channel	Frequency (MHz)	6dB Bandwidth (MHz)	Minimum Limit (MHz)	Pass / Fail
1	2412	16.16	0.5	Pass
6	2437	16.06	0.5	Pass
11	2462	16.06	0.5	Pass

802.11n (HT20)

Channel	Frequency (MHz)	6dB Bandwidth (MHz)	Minimum Limit (MHz)	Pass / Fail
1	2412	16.89	0.5	Pass
6	2437	16.84	0.5	Pass
11	2462	17.20	0.5	Pass

802.11n (HT40)

Channel	Frequency (MHz)	6dB Bandwidth (MHz)	Minimum Limit (MHz)	Pass / Fail
3	2422	35.51	0.5	Pass
6	2437	35.47	0.5	Pass
9	2452	35.27	0.5	Pass

Spectrum Plot of Worst Value

802.11b

802.11g

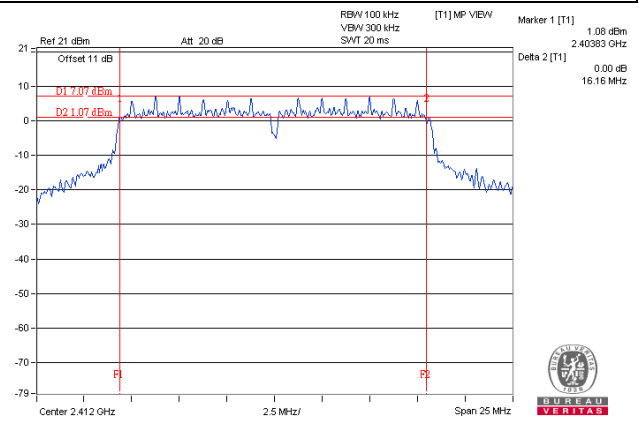
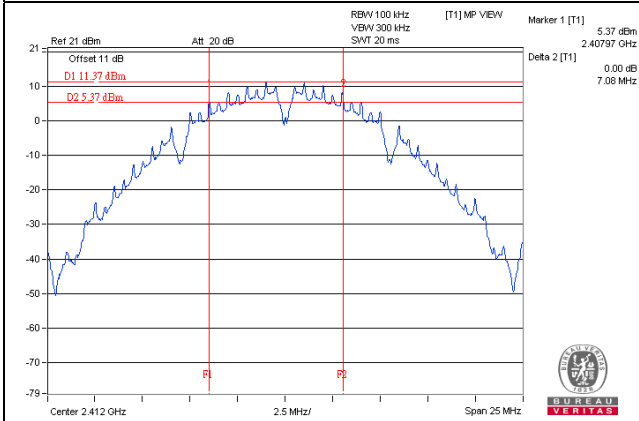

802.11n (HT20)

802.11n (HT40)

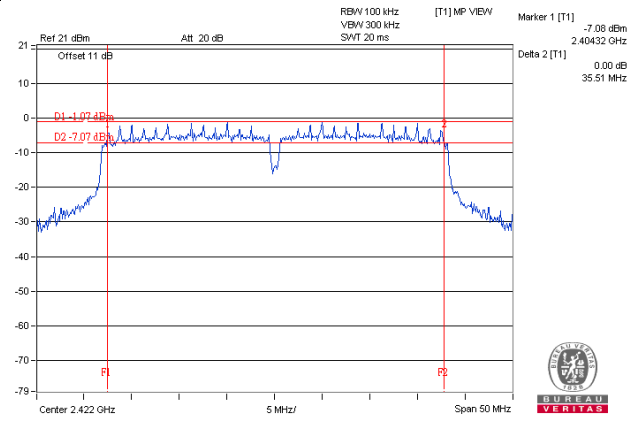
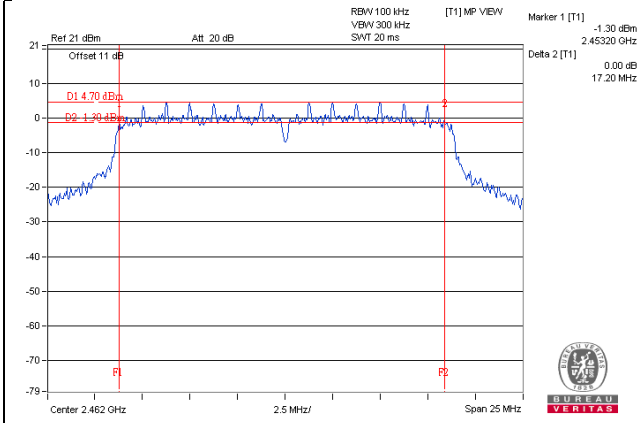

4.4 Conducted Output Power Measurement

4.4.1 Limits of Conducted Output Power Measurement

For systems using digital modulation in the 2400–2483.5 MHz bands: 1 Watt (30dBm)

Per KDB 662911 D01 Multiple Transmitter Output Method of conducted output power measurement on IEEE 802.11 devices,

Array Gain = 0 dB (i.e., no array gain) for $NANT \leq 4$;

Array Gain = 0 dB (i.e., no array gain) for channel widths ≥ 40 MHz for any NANT;

Array Gain = $5 \log(NANT/NSS)$ dB or 3 dB, whichever is less for 20-MHz channel widths with $NANT \geq 5$.

For power measurements on all other devices: Array Gain = $10 \log(NANT/NSS)$ dB.

4.4.2 Test Setup

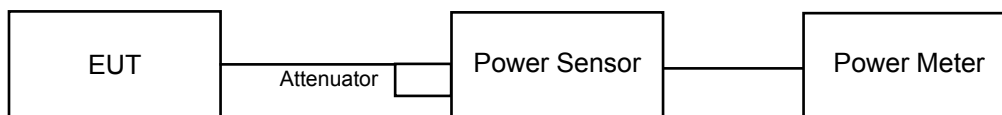

4.4.3 Test Instruments

Refer to section 4.1.2 to get information of above instrument.

4.4.4 Test Procedures

For Radio 1

An average power sensor was used on the output port of the EUT. A power meter was used to read the response of the average power sensor. Record the power level.

For Radio 3

A peak power sensor was used on the output port of the EUT. A power meter was used to read the response of the peak power sensor. Record the power level.

An average power sensor was used on the output port of the EUT. A power meter was used to read the response of the average power sensor. Record the power level.

4.4.5 Deviation from Test Standard

No deviation.

4.4.6 EUT Operating Conditions

Same as Item 4.3.6.

4.4.7 Test Results

Radio 1: CDD Mode

802.11b

Channel	Frequency (MHz)	Average Power (dBm)		Total Power (mW)	Total Power (dBm)	Limit (dBm)	Pass / Fail
		Chain 0	Chain 1				
1	2412	19.75	19.50	183.531	22.64	30	Pass
6	2437	19.53	19.55	179.900	22.55	30	Pass
11	2462	19.66	19.65	184.727	22.67	30	Pass

802.11g

Channel	Frequency (MHz)	Average Power (dBm)		Total Power (mW)	Total Power (dBm)	Limit (dBm)	Pass / Fail
		Chain 0	Chain 1				
1	2412	15.65	15.55	72.620	18.61	30	Pass
6	2437	19.34	19.44	173.803	22.40	30	Pass
11	2462	16.18	16.33	84.449	19.27	30	Pass

802.11n (HT20)

Channel	Frequency (MHz)	Average Power (dBm)		Total Power (mW)	Total Power (dBm)	Limit (dBm)	Pass / Fail
		Chain 0	Chain 1				
1	2412	13.23	13.46	43.220	16.36	30	Pass
6	2437	19.23	19.45	171.858	22.35	30	Pass
11	2462	14.61	14.87	59.597	17.75	30	Pass

802.11n (HT40)

Channel	Frequency (MHz)	Average Power (dBm)		Total Power (mW)	Total Power (dBm)	Limit (dBm)	Pass / Fail
		Chain 0	Chain 1				
3	2422	12.31	12.62	35.303	15.48	30	Pass
6	2437	15.94	15.80	77.283	18.88	30	Pass
9	2452	13.26	13.32	42.662	16.30	30	Pass

Radio 1: Beamforming Mode

802.11n (HT20)

Channel	Frequency (MHz)	Average Power (dBm)		Total Power (mW)	Total Power (dBm)	Limit (dBm)	Pass / Fail
		Chain 0	Chain 1				
1	2412	13.05	13.10	40.601	16.09	29.03	Pass
6	2437	18.82	18.72	150.681	21.78	29.03	Pass
11	2462	13.84	13.99	49.271	16.93	29.03	Pass

Note: Directional gain = $10 \log[(10^{G1/20} + 10^{G2/20} + \dots + 10^{GN/20})^2/2] = 6.97\text{dBi} > 6\text{dBi}$, so the power limit shall be reduced to $30 - (6.97 - 6) = 29.03\text{dBm}$.

802.11n (HT40)

Channel	Frequency (MHz)	Average Power (dBm)		Total Power (mW)	Total Power (dBm)	Limit (dBm)	Pass / Fail
		Chain 0	Chain 1				
3	2422	10.19	10.03	20.516	13.12	29.03	Pass
6	2437	15.18	15.15	65.695	18.18	29.03	Pass
9	2452	12.89	12.87	38.818	15.89	29.03	Pass

Note: Directional gain = $10 \log[(10^{G1/20} + 10^{G2/20} + \dots + 10^{GN/20})^2/2] = 6.97\text{dBi} > 6\text{dBi}$, so the power limit shall be reduced to $30 - (6.97 - 6) = 29.03\text{dBm}$.

Radio 3: CDD Mode

Peak Power

802.11b

Channel	Frequency (MHz)	Peak Power (mW)	Peak Power (dBm)	Limit (dBm)	Pass / Fail
1	2412	129.42	21.12	30	Pass
6	2437	100.231	20.01	30	Pass
11	2462	115.611	20.63	30	Pass

802.11g

Channel	Frequency (MHz)	Peak Power (mW)	Peak Power (dBm)	Limit (dBm)	Pass / Fail
1	2412	116.413	20.66	30	Pass
6	2437	152.405	21.83	30	Pass
11	2462	92.683	19.67	30	Pass

802.11n (HT20)

Channel	Frequency (MHz)	Peak Power (mW)	Peak Power (dBm)	Limit (dBm)	Pass / Fail
1	2412	88.716	19.48	30	Pass
6	2437	157.761	21.98	30	Pass
11	2462	77.625	18.90	30	Pass

802.11n (HT40)

Channel	Frequency (MHz)	Peak Power (mW)	Peak Power (dBm)	Limit (dBm)	Pass / Fail
3	2422	44.055	16.44	30	Pass
6	2437	117.761	20.71	30	Pass
9	2452	32.285	15.09	30	Pass

Average Power

802.11b

Channel	Frequency (MHz)	Average Power (mW)	Average Power (dBm)
1	2412	69.663	18.43
6	2437	52.966	17.24
11	2462	63.387	18.02

802.11g

Channel	Frequency (MHz)	Average Power (mW)	Average Power (dBm)
1	2412	49.091	16.91
6	2437	71.614	18.55
11	2462	39.446	15.96

802.11n (HT20)

Channel	Frequency (MHz)	Average Power (mW)	Average Power (dBm)
1	2412	34.914	15.43
6	2437	71.121	18.52
11	2462	30.761	14.88

802.11n (HT40)

Channel	Frequency (MHz)	Average Power (mW)	Average Power (dBm)
3	2422	17.701	12.48
6	2437	49.204	16.92
9	2452	12.246	10.88

4.5 Power Spectral Density Measurement

4.5.1 Limits of Power Spectral Density Measurement

The Maximum of Power Spectral Density Measurement is 8dBm.

4.5.2 Test Setup

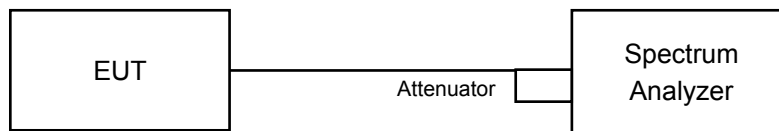

4.5.3 Test Instruments

Refer to section 4.1.2 to get information of above instrument.

4.5.4 Test Procedure

For Radio 1 (duty cycle $\geq 98\%$)

- a. Set instrument center frequency to DTS channel center frequency.
- b. Set span to at least 1.5 times the OBW.
- c. Set RBW to: $3 \text{ kHz} \leq \text{RBW} \leq 100 \text{ kHz}$.
- d. Set VBW $\geq 3 \times \text{RBW}$.
- e. Detector = power averaging (RMS) or sample detector (when RMS not available).
- f. Ensure that the number of measurement points in the sweep $\geq 2 \times \text{span}/\text{RBW}$.
- g. Sweep time = auto couple.
- h. Employ trace averaging (RMS) mode over a minimum of 100 traces.
- i. Use the peak marker function to determine the maximum amplitude level.

For Radio 1 (duty cycle $< 98\%$)

- a. Measure the duty cycle (x).
- b. Set instrument center frequency to DTS channel center frequency.
- c. Set span to at least 1.5 times the OBW.
- d. Set RBW to: $3 \text{ kHz} \leq \text{RBW} \leq 100 \text{ kHz}$.
- e. Set VBW $\geq 3 \times \text{RBW}$.
- f. Detector = power averaging (RMS) or sample detector (when RMS not available).
- g. Ensure that the number of measurement points in the sweep $\geq 2 \times \text{span}/\text{RBW}$.
- h. Sweep time = auto couple.
- i. Do not use sweep triggering. Allow sweep to "free run".
- j. Employ trace averaging (RMS) mode over a minimum of 100 traces.
- k. Use the peak marker function to determine the maximum amplitude level.
- l. Add $10 \log (1/x)$, where x is the duty cycle measured in step (a), to the measured PSD to compute the average PSD during the actual transmission time.

For Radio 3

- a. Set analyzer center frequency to DTS channel center frequency.
- b. Set the span to 1.5 times the DTS bandwidth.
- c. Set the RBW to: $3 \text{ kHz} \leq \text{RBW} \leq 100 \text{ kHz}$.
- d. Set the VBW $\geq 3 \times \text{RBW}$.
- e. Detector = peak.
- f. Sweep time = auto couple.
- g. Trace mode = max hold.
- h. Allow trace to fully stabilize.
- i. Use the peak marker function to determine the maximum amplitude level within the RBW.

4.5.5 Deviation from Test Standard

No deviation.

4.5.6 EUT Operating Condition

Same as Item 4.3.6

4.5.7 Test Results

Radio 1: CDD Mode

802.11b

TX chain	Channel	Frequency (MHz)	PSD (dBm)	10 log (N=2) dB	Total PSD (dBm)	Limit (dBm)	Pass / Fail
0	1	2412	-7.17	3.01	-4.16	7.03	Pass
	6	2437	-7.00	3.01	-3.99	7.03	Pass
	11	2462	-6.90	3.01	-3.89	7.03	Pass
1	1	2412	-6.94	3.01	-3.93	7.03	Pass
	6	2437	-6.92	3.01	-3.91	7.03	Pass
	11	2462	-7.08	3.01	-4.07	7.03	Pass

Note:

- Method 1 of power density measurement of KDB 662911 is using for calculating total power density. Total power density is summing entire spectra across corresponding frequency bins on the various outputs by computer.
- Directional gain = $10 \log[(10^{G1/20} + 10^{G2/20} + \dots + 10^{GN/20})^2/2] = 6.97\text{dBi} > 6\text{dBi}$, so the power density limit shall be reduced to $8 - (6.97 - 6) = 7.03\text{dBm}$

802.11g

TX chain	Channel	Frequency (MHz)	PSD (dBm)	10 log (N=2) dB	Duty Factor	Total PSD with Duty Factor (dBm)	Limit (dBm)	Pass / Fail
0	1	2412	-14.09	3.01	0.18	-10.90	7.03	Pass
	6	2437	-10.38	3.01	0.18	-7.19	7.03	Pass
	11	2462	-13.13	3.01	0.18	-9.94	7.03	Pass
1	1	2412	-14.36	3.01	0.18	-11.17	7.03	Pass
	6	2437	-10.32	3.01	0.18	-7.13	7.03	Pass
	11	2462	-13.62	3.01	0.18	-10.43	7.03	Pass

Note:

- Method 1 of power density measurement of KDB 662911 is using for calculating total power density. Total power density is summing entire spectra across corresponding frequency bins on the various outputs by computer.
- Directional gain = $10 \log[(10^{G1/20} + 10^{G2/20} + \dots + 10^{GN/20})^2/2] = 6.97\text{dBi} > 6\text{dBi}$, so the power density limit shall be reduced to $8 - (6.97 - 6) = 7.03\text{dBm}$
- Refer to section 3.3 for duty cycle spectrum plot.

802.11n (HT20)

TX chain	Channel	Frequency (MHz)	PSD (dBm)	10 log (N=2) dB	Total PSD (dBm)	Limit (dBm)	Pass / Fail
0	1	2412	-16.22	3.01	-13.21	7.03	Pass
	6	2437	-10.08	3.01	-7.07	7.03	Pass
	11	2462	-14.54	3.01	-11.53	7.03	Pass
1	1	2412	-15.60	3.01	-12.59	7.03	Pass
	6	2437	-10.12	3.01	-7.11	7.03	Pass
	11	2462	-14.36	3.01	-11.35	7.03	Pass

Note:

- Method 1 of power density measurement of KDB 662911 is using for calculating total power density. Total power density is summing entire spectra across corresponding frequency bins on the various outputs by computer.
- Directional gain = $10 \log[(10^{G1/20} + 10^{G2/20} + \dots + 10^{GN/20})^2/2] = 6.97\text{dBi} > 6\text{dBi}$, so the power density limit shall be reduced to $8 - (6.97 - 6) = 7.03\text{dBm}$

802.11n (HT40)

TX chain	Channel	Frequency (MHz)	PSD (dBm)	10 log (N=2) dB	Duty Factor	Total PSD with Duty Factor (dBm)	Limit (dBm)	Pass / Fail
0	3	2422	-20.05	3.01	0.18	-16.86	7.03	Pass
	6	2437	-16.83	3.01	0.18	-13.64	7.03	Pass
	9	2452	-19.65	3.01	0.18	-16.46	7.03	Pass
1	3	2422	-20.19	3.01	0.18	-17.00	7.03	Pass
	6	2437	-16.68	3.01	0.18	-13.49	7.03	Pass
	9	2452	-19.45	3.01	0.18	-16.26	7.03	Pass

Note:

- Method 1 of power density measurement of KDB 662911 is using for calculating total power density. Total power density is summing entire spectra across corresponding frequency bins on the various outputs by computer.
- Directional gain = $10 \log[(10^{G1/20} + 10^{G2/20} + \dots + 10^{GN/20})^2/2] = 6.97\text{dBi} > 6\text{dBi}$, so the power density limit shall be reduced to $8 - (6.97 - 6) = 7.03\text{dBm}$
- Refer to section 3.3 for duty cycle spectrum plot.

Spectrum Plot of Worst Value

802.11b

802.11g

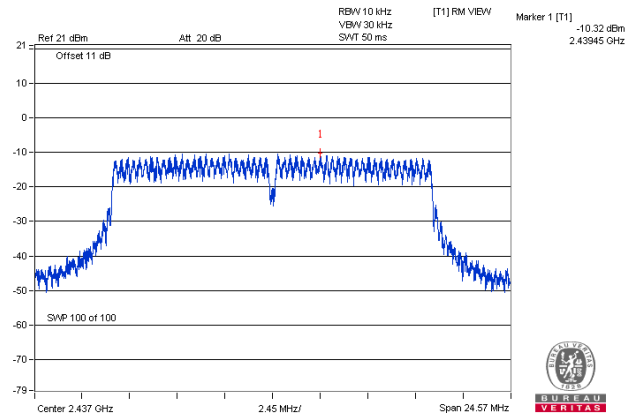
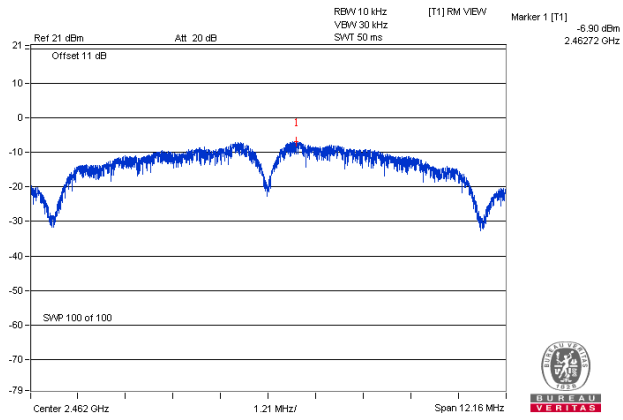

802.11n (HT20)

802.11n (HT40)

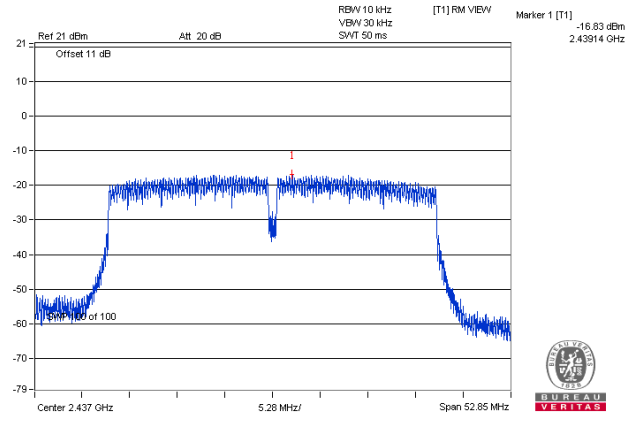
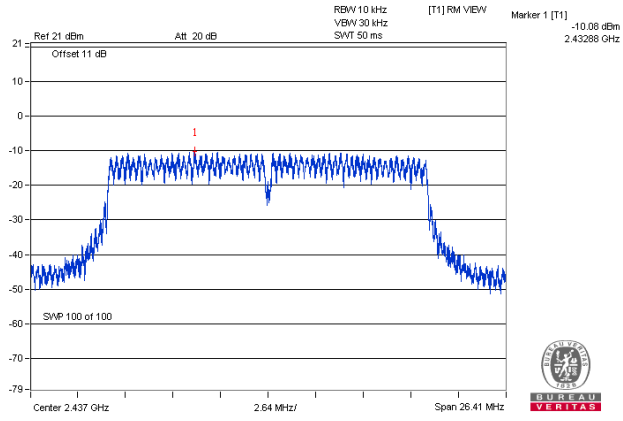

Radio 1: Beamforming Mode

802.11n (HT20)

TX chain	Channel	Frequency (MHz)	PSD (dBm)	10 log (N=2) dB	Duty Factor	Total PSD with Duty Factor (dBm)	Limit (dBm)	Pass / Fail
0	1	2412	-18.68	3.01	0.09	-15.58	7.03	Pass
	6	2437	-13.39	3.01	0.09	-10.29	7.03	Pass
	11	2462	-17.71	3.01	0.09	-14.61	7.03	Pass
1	1	2412	-18.52	3.01	0.09	-15.42	7.03	Pass
	6	2437	-12.88	3.01	0.09	-9.78	7.03	Pass
	11	2462	-17.44	3.01	0.09	-14.34	7.03	Pass

Note:

- Method 1 of power density measurement of KDB 662911 is using for calculating total power density. Total power density is summing entire spectra across corresponding frequency bins on the various outputs by computer.
- Directional gain = $10 \log[(10^{G1/20} + 10^{G2/20} + \dots + 10^{GN/20})^2/2] = 6.97\text{dBi} > 6\text{dBi}$, so the power density limit shall be reduced to $8 - (6.97 - 6) = 7.03\text{dBm}$

802.11n (HT40)

TX chain	Channel	Frequency (MHz)	PSD (dBm)	10 log (N=2) dB	Duty Factor	Total PSD with Duty Factor (dBm)	Limit (dBm)	Pass / Fail
0	3	2422	-24.74	3.01	0.18	-21.55	7.03	Pass
	6	2437	-19.80	3.01	0.18	-16.61	7.03	Pass
	9	2452	-21.66	3.01	0.18	-18.47	7.03	Pass
1	3	2422	-24.86	3.01	0.18	-21.67	7.03	Pass
	6	2437	-19.79	3.01	0.18	-16.60	7.03	Pass
	9	2452	-21.69	3.01	0.18	-18.50	7.03	Pass

Note:

- Method 1 of power density measurement of KDB 662911 is using for calculating total power density. Total power density is summing entire spectra across corresponding frequency bins on the various outputs by computer.
- Directional gain = $10 \log[(10^{G1/20} + 10^{G2/20} + \dots + 10^{GN/20})^2/2] = 6.97\text{dBi} > 6\text{dBi}$, so the power density limit shall be reduced to $8 - (6.97 - 6) = 7.03\text{dBm}$
- Refer to section 3.3 for duty cycle spectrum plot.

Spectrum Plot of Worst Value

802.11n (HT20)

802.11n (HT40)

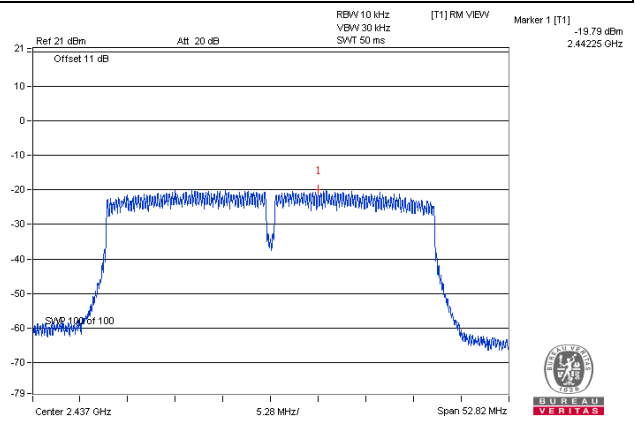
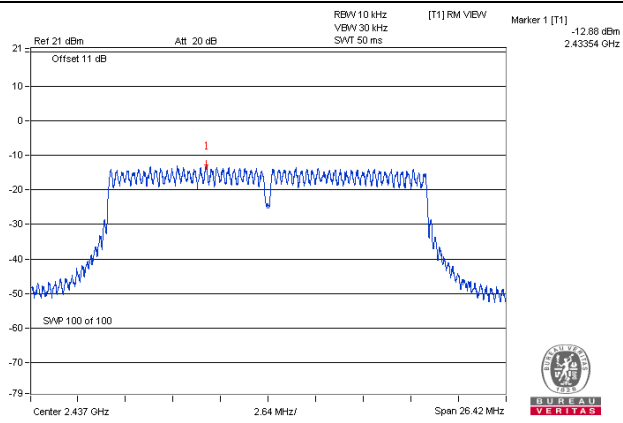

Radio 3: CDD Mode

802.11b

Channel	Frequency (MHz)	PSD (dBm)	Limit (dBm)	Pass / Fail
1	2412	2.54	8.00	Pass
6	2437	3.27	8.00	Pass
11	2462	2.83	8.00	Pass

802.11g

Channel	Frequency (MHz)	PSD (dBm)	Limit (dBm)	Pass / Fail
1	2412	-8.90	8.00	Pass
6	2437	-7.27	8.00	Pass
11	2462	-9.81	8.00	Pass

802.11n (HT20)

Channel	Frequency (MHz)	PSD (dBm)	Limit (dBm)	Pass / Fail
1	2412	-11.53	8.00	Pass
6	2437	-7.83	8.00	Pass
11	2462	-11.54	8.00	Pass

802.11n (HT40)

Channel	Frequency (MHz)	PSD (dBm)	Limit (dBm)	Pass / Fail
3	2422	-17.30	8.00	Pass
6	2437	-13.02	8.00	Pass
9	2452	-18.75	8.00	Pass

Spectrum Plot of Worst Value

802.11b

802.11g

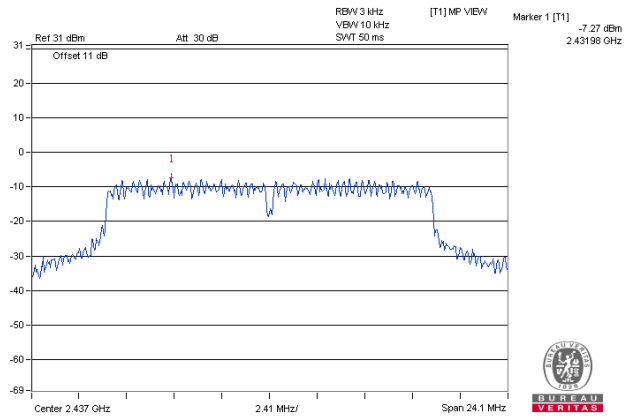
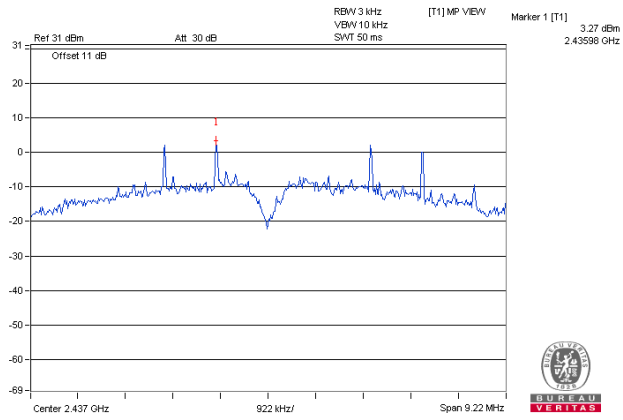

802.11n (HT20)

802.11n (HT40)

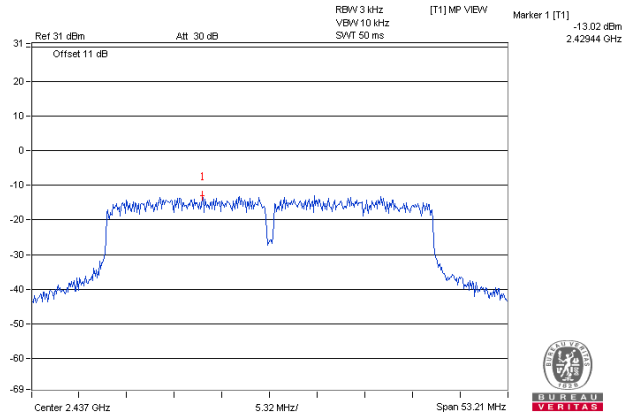
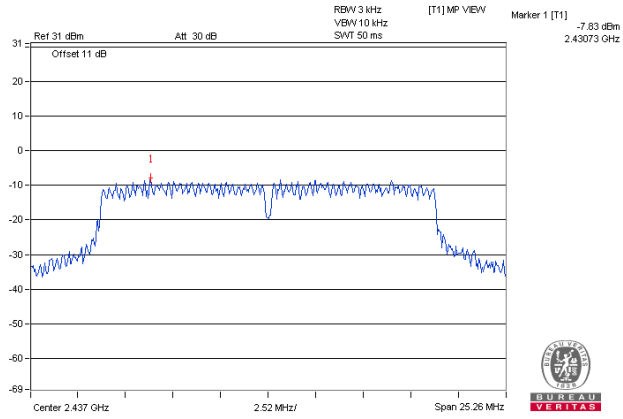

4.6 Conducted Out of Band Emission Measurement

4.6.1 Limits of Conducted Out of Band Emission Measurement

Below 20dB / 30dB of the highest emission level of operating band (in 100kHz Resolution Bandwidth).

4.6.2 Test Setup

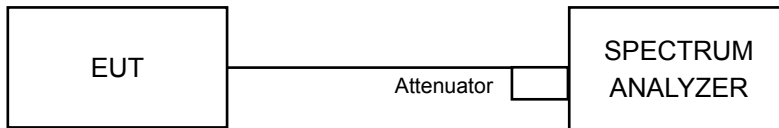

4.6.3 Test Instruments

Refer to section 4.1.2 to get information of above instrument.

4.6.4 Test Procedure

MEASUREMENT PROCEDURE REF

- Set the RBW = 100 kHz.
- Set the VBW \geq 300 kHz.
- Detector = peak.
- Sweep time = auto couple.
- Trace mode = max hold.
- Allow trace to fully stabilize.
- Use the peak marker function to determine the maximum power level in any 100 kHz band segment within the fundamental EBW.

MEASUREMENT PROCEDURE OOB

- Set RBW = 100 kHz.
- Set VBW \geq 300 kHz.
- Ensure that the number of measurement points \geq span/RBW
- According to measurement points to set differ measurement span.
- Detector = peak.
- Trace Mode = max hold.
- Sweep = auto couple.

4.6.5 Deviation from Test Standard

No deviation.

4.6.6 EUT Operating Condition

Same as Item 4.3.6

4.6.7 Test Results

The spectrum plots are attached on the following pages. D1 line indicates the highest level, and D2 line indicates the 20dB / 30dB offset below D1. It shows compliance with the requirement.

Radio 1: CDD Mode
802.11b_Chain 0

CH 1

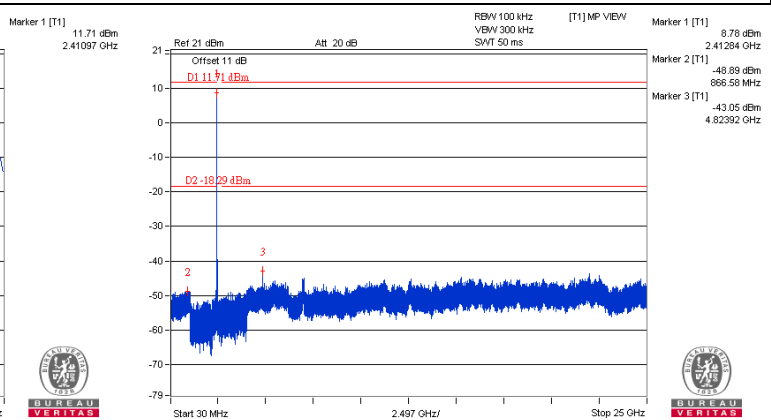
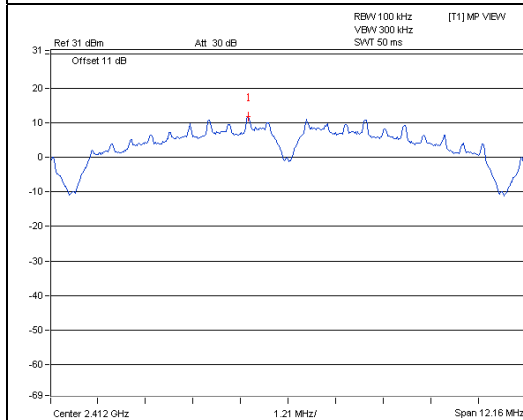

CH 6

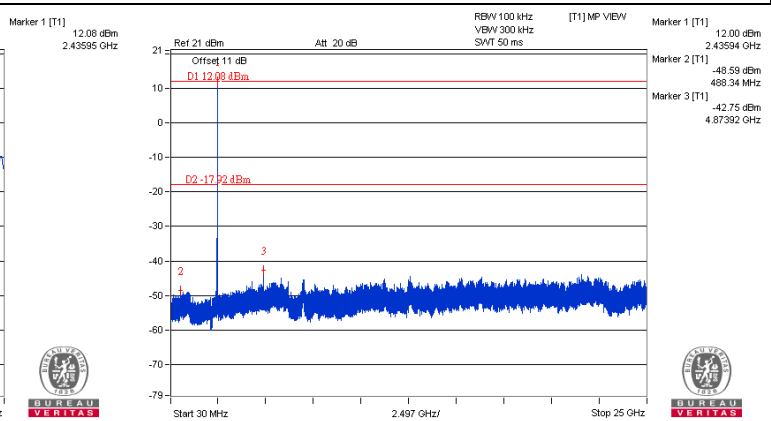
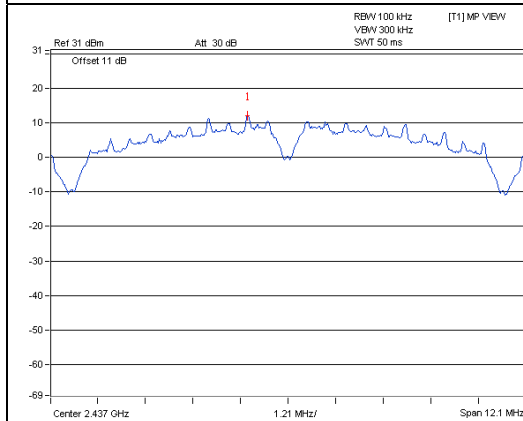

CH 11

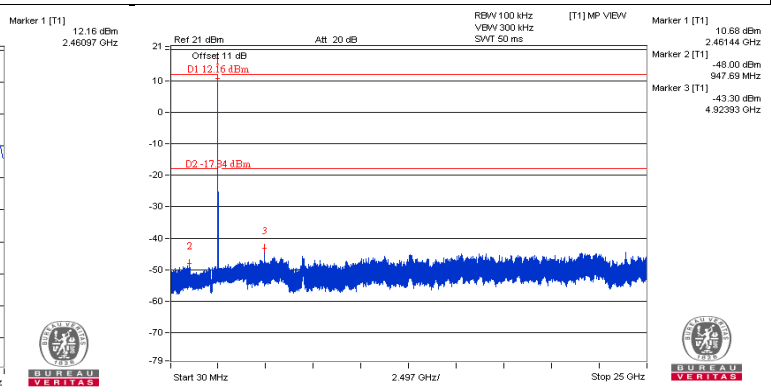
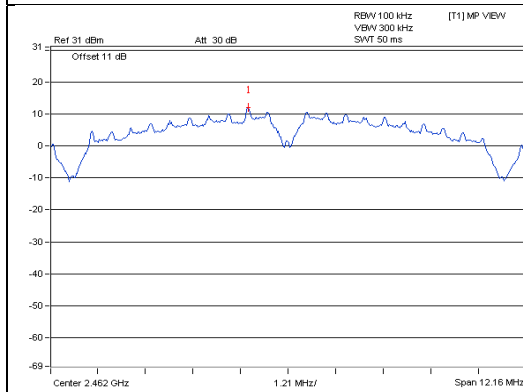

CH 1 Band edge

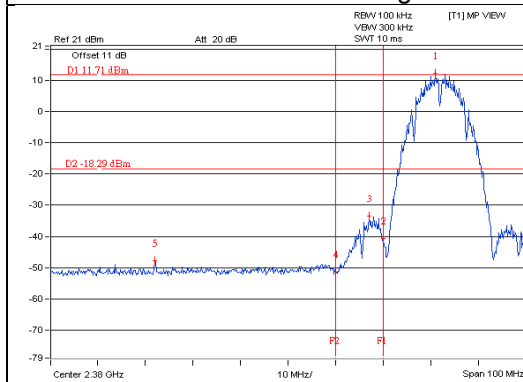

CH 11 Band edge

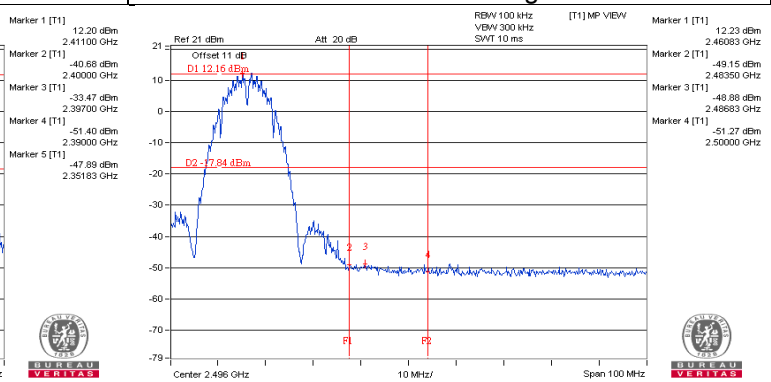

802.11b_Chain 1

CH 1

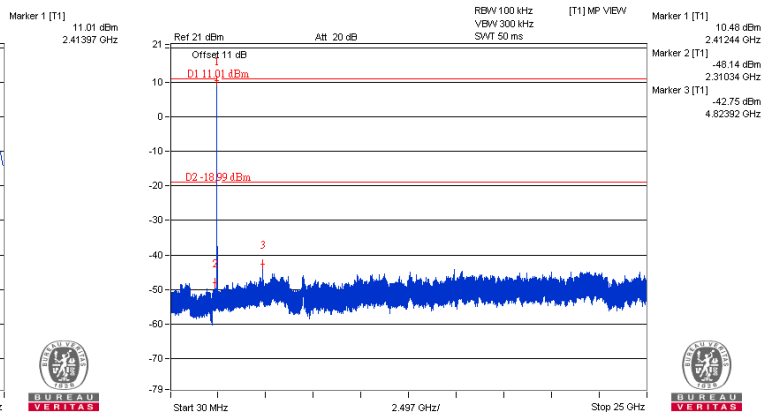
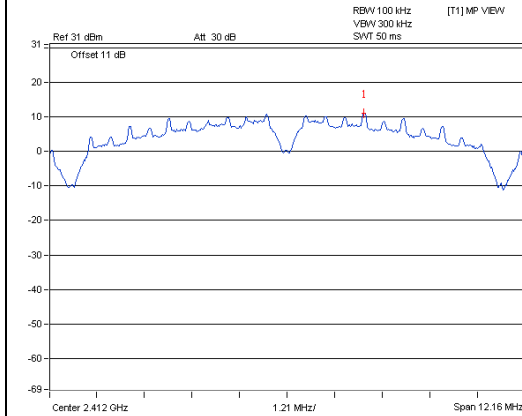

CH 6

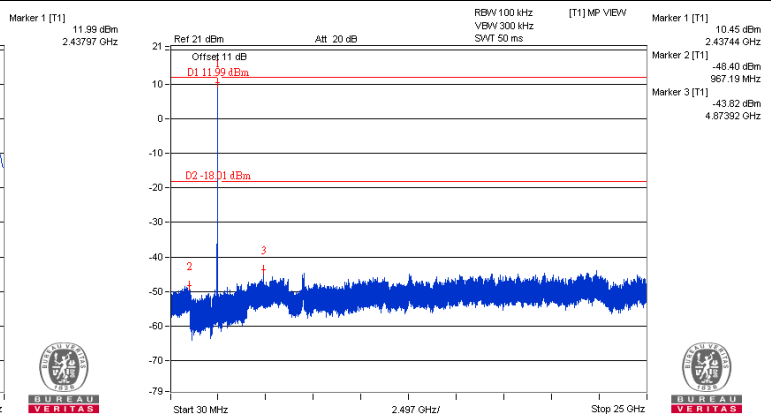
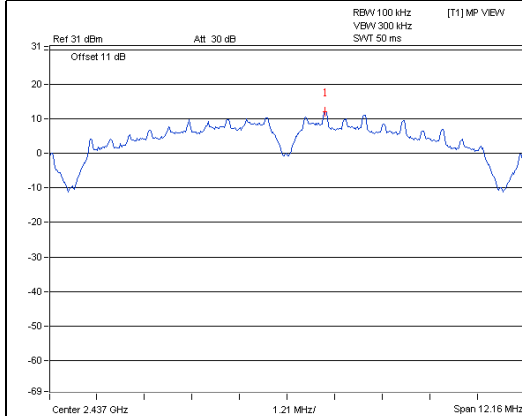

CH 11

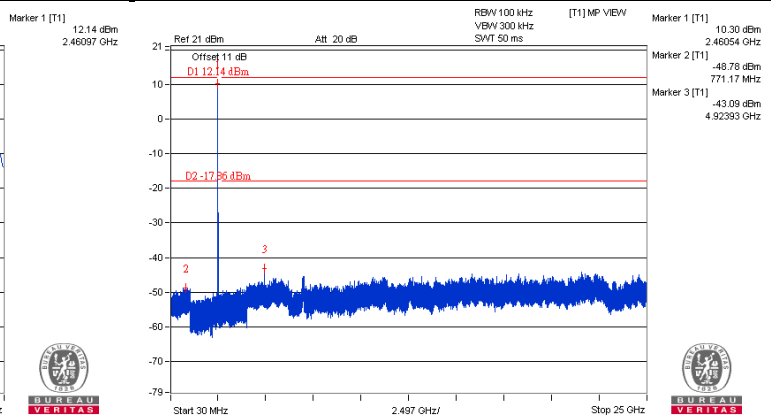
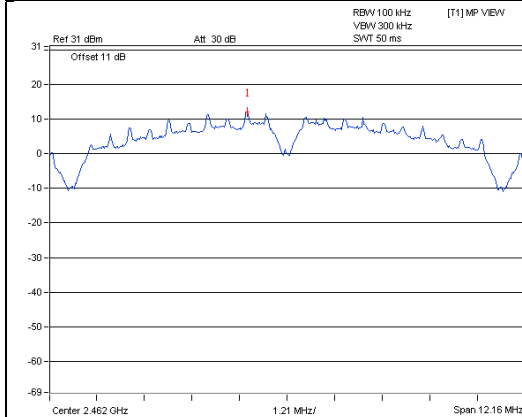

CH 1 Band edge

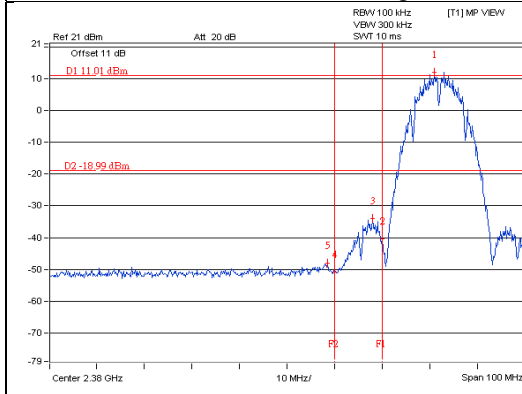

CH 11 Band edge

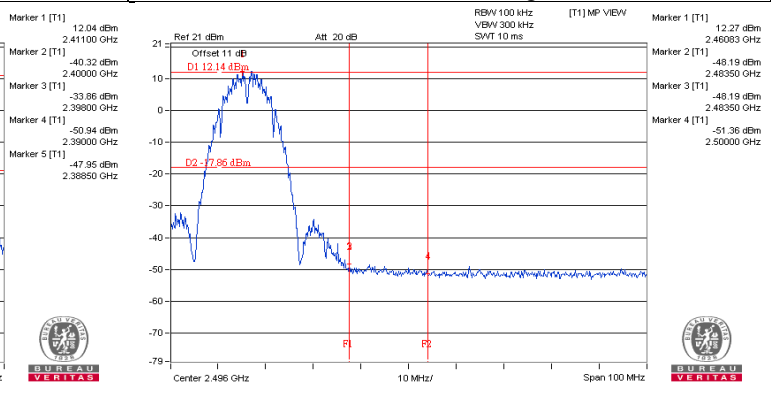

802.11g_Chain 0

CH 1

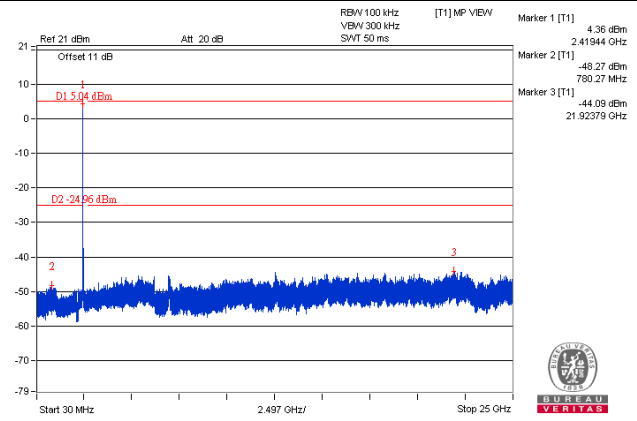
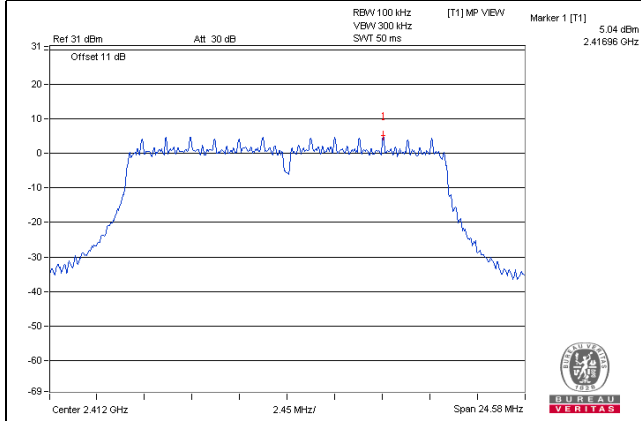

CH 6

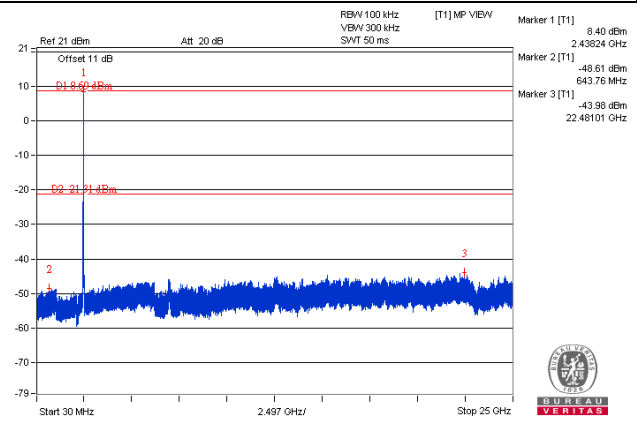
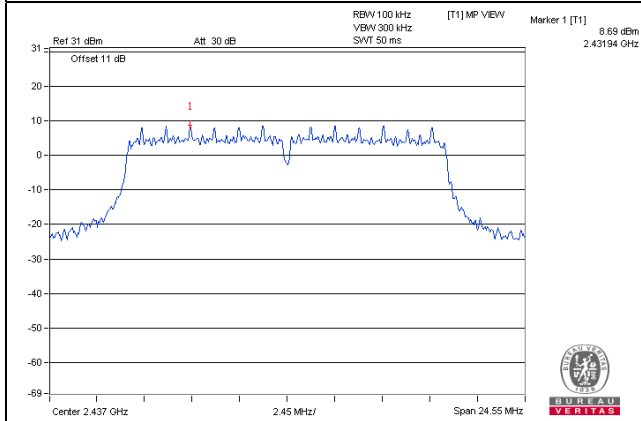

CH 11

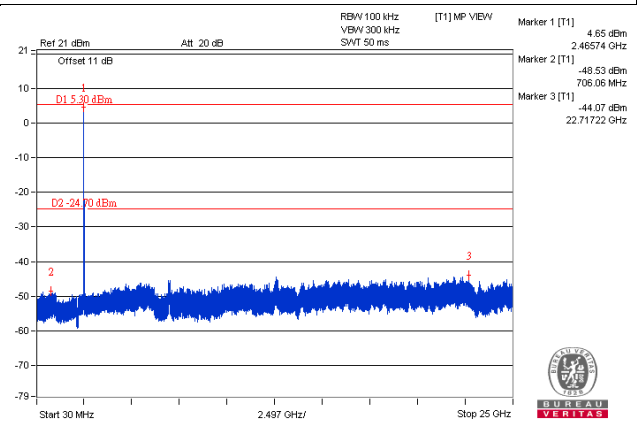
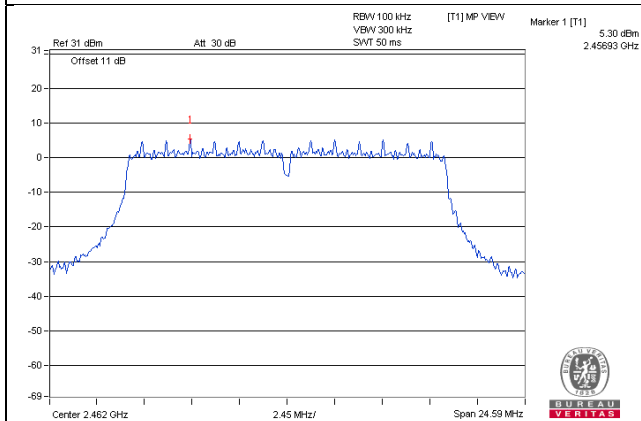

CH 1 Band edge

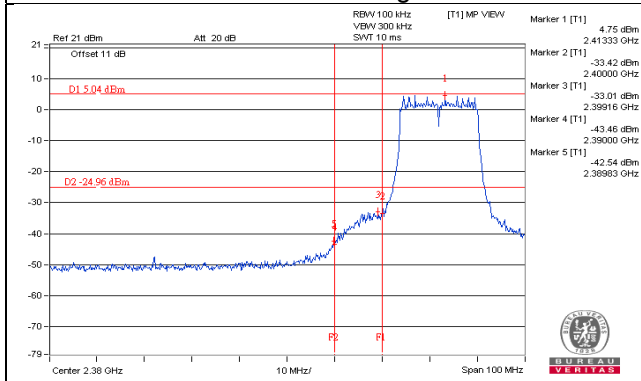

CH 11 Band edge

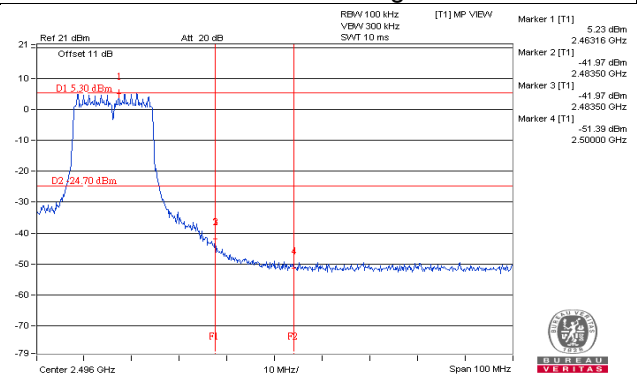

802.11g_Chain 1

CH 1

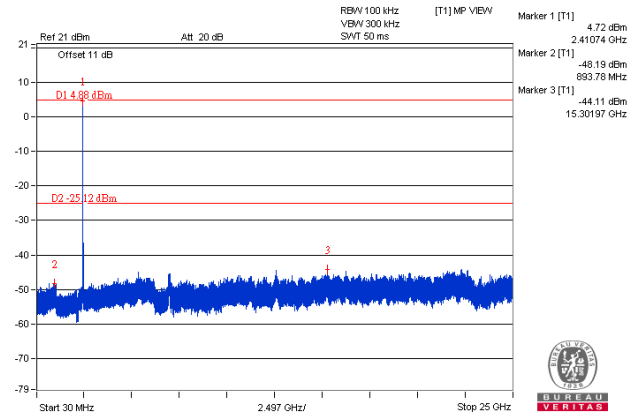
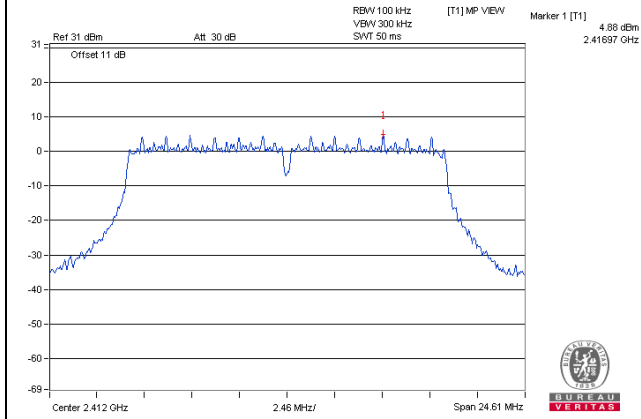

CH 6

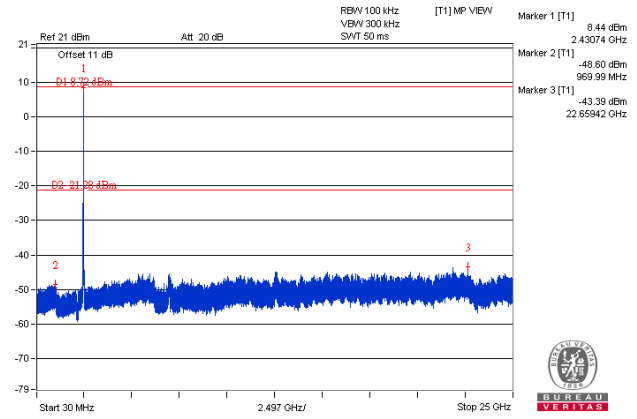
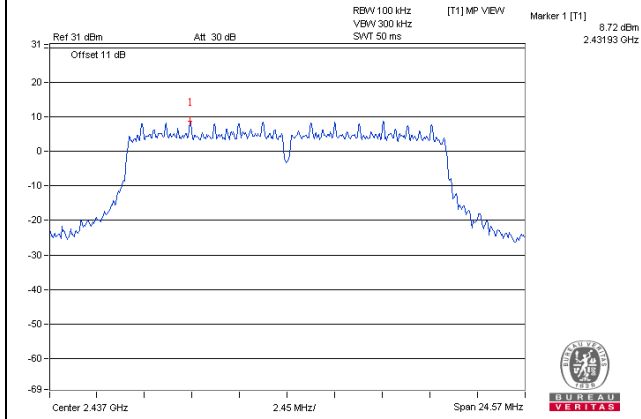

CH 11

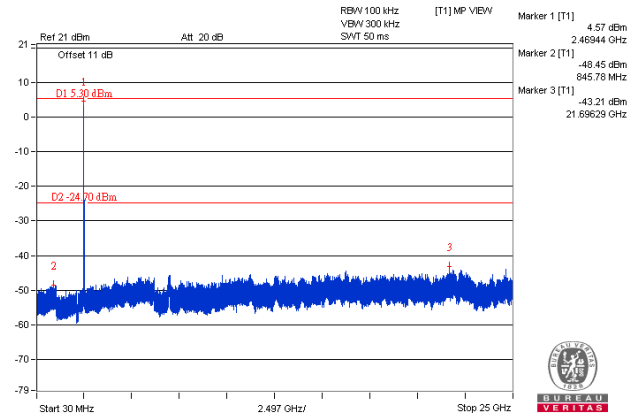
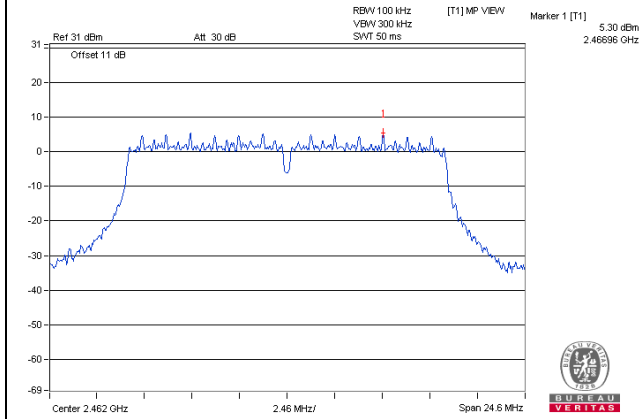

CH 1 Band edge

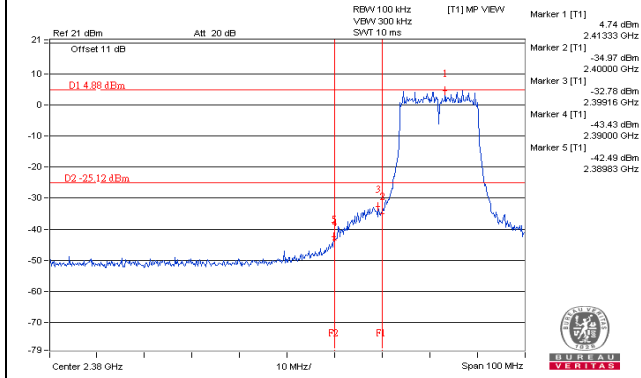

CH 11 Band edge

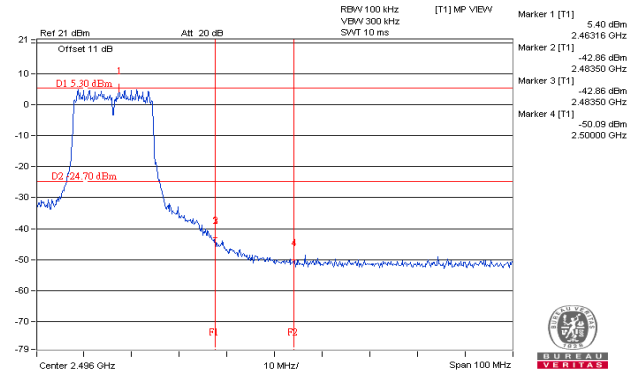

802.11n (HT20)_Chain 0

CH 1

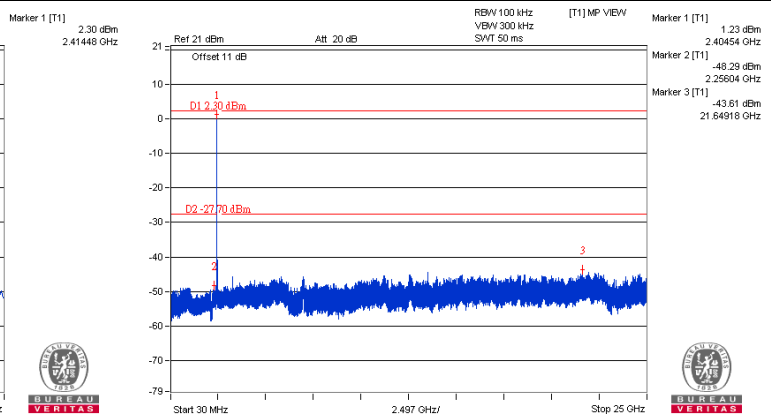
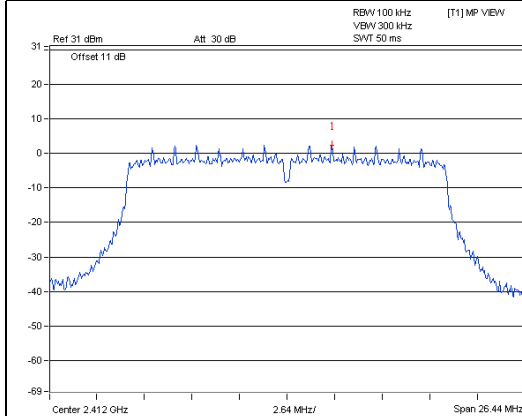

CH 6

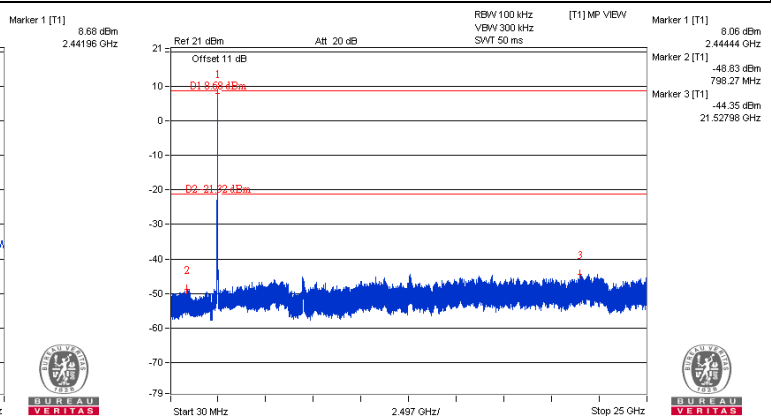
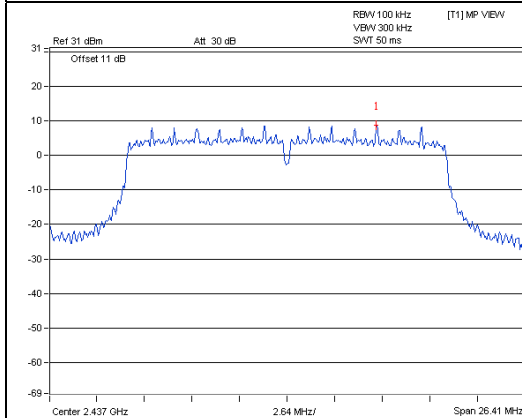

CH 11

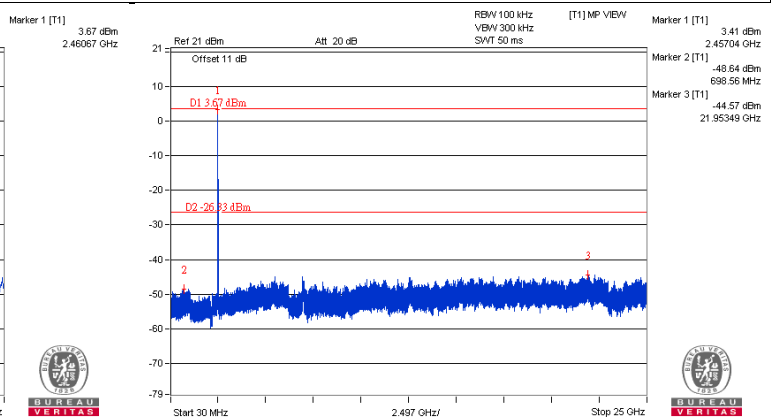
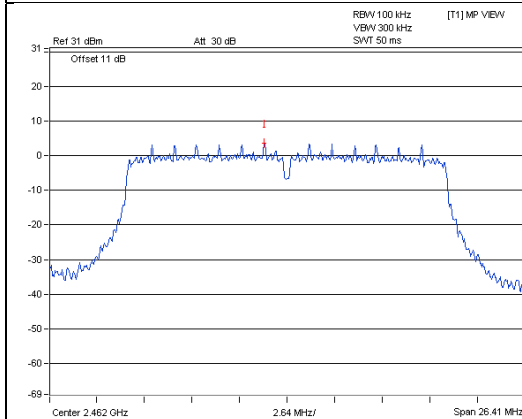

CH 1 Band edge

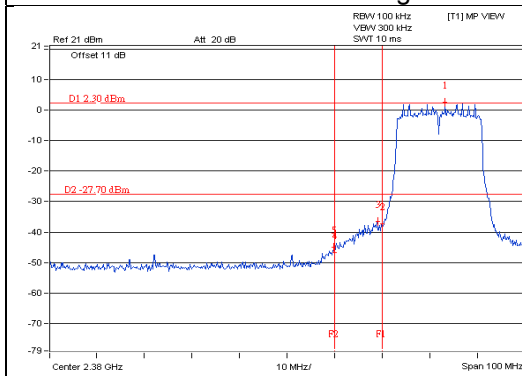

CH 11 Band edge

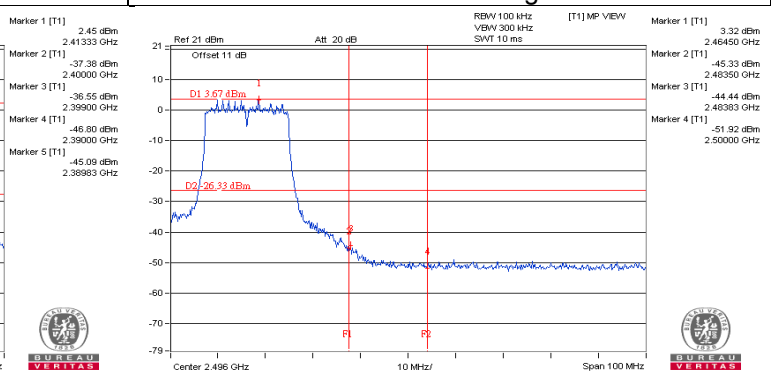

802.11n (HT20)_Chain 1

CH 1

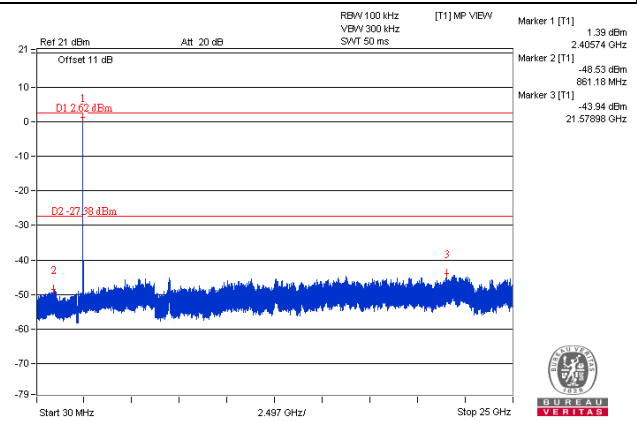
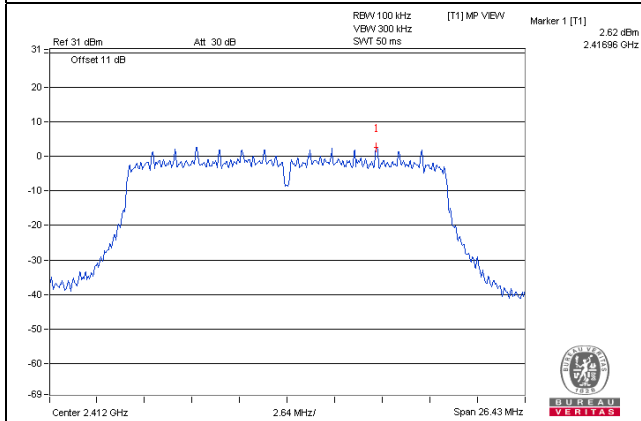

CH 6

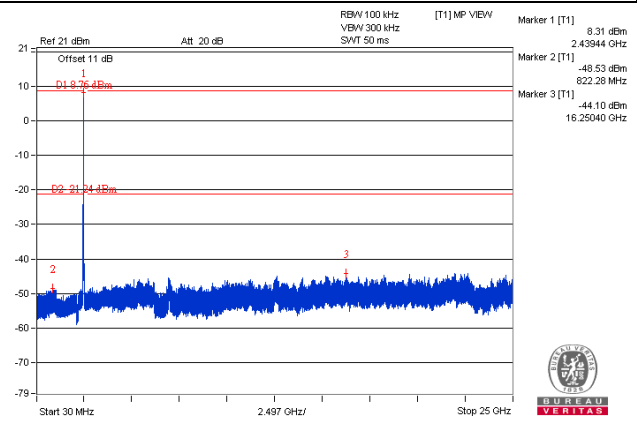
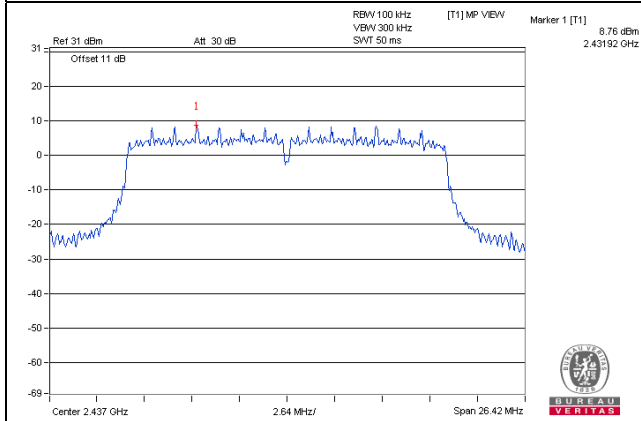

CH 11

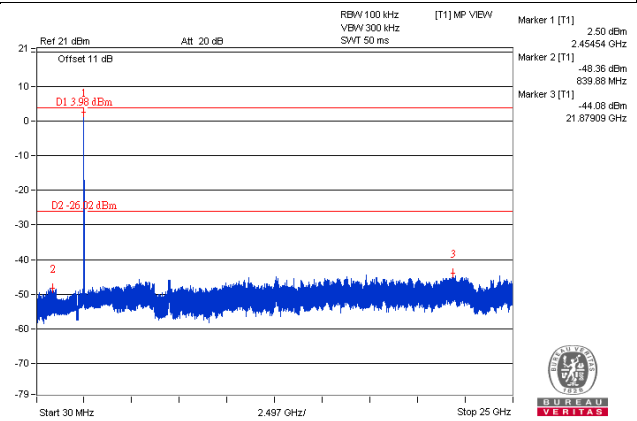
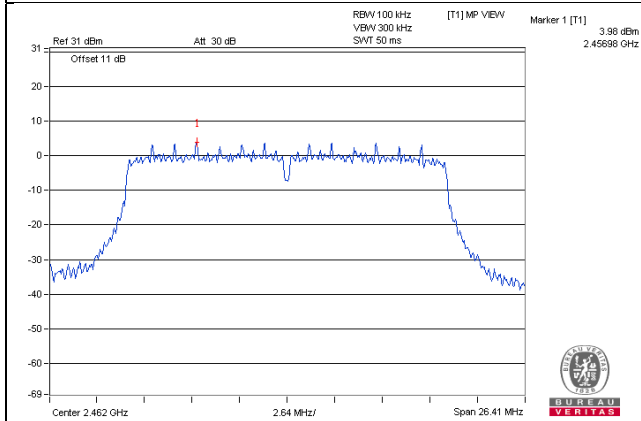

CH 1 Band edge

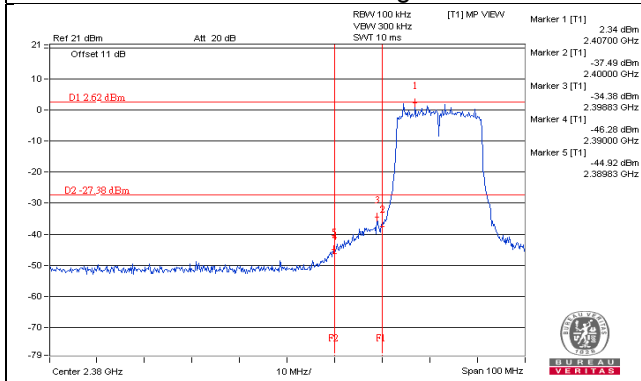

CH 11 Band edge

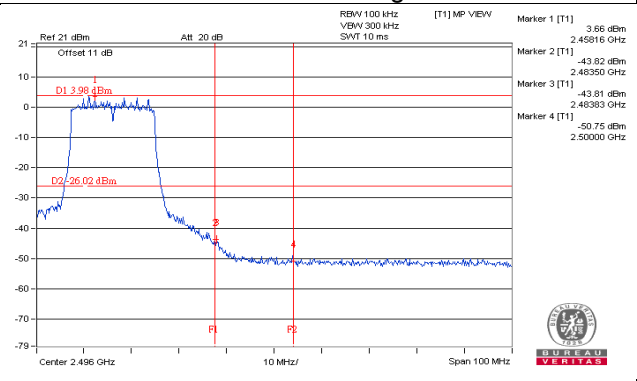

802.11n (HT40)_Chain 0

CH 3

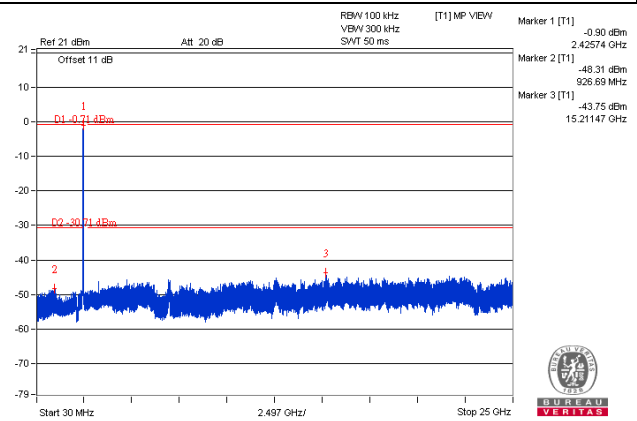
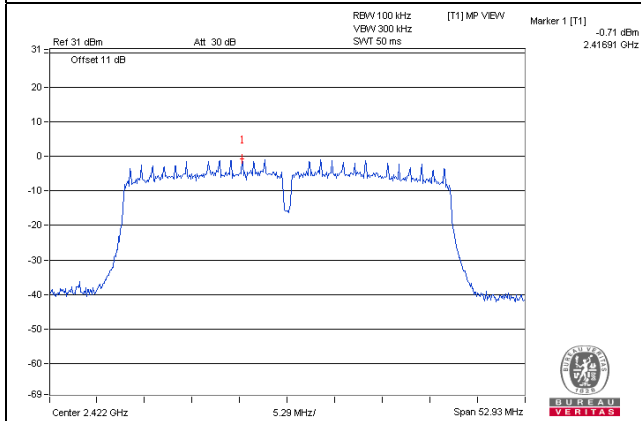

CH 6

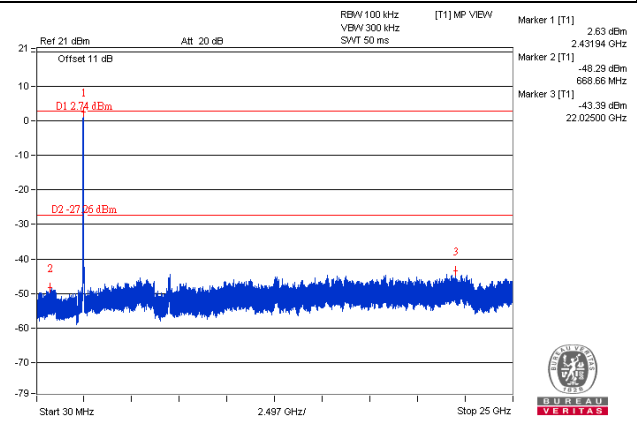
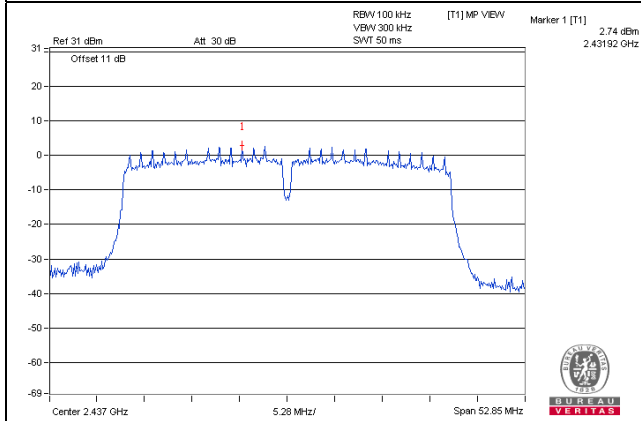

CH 9

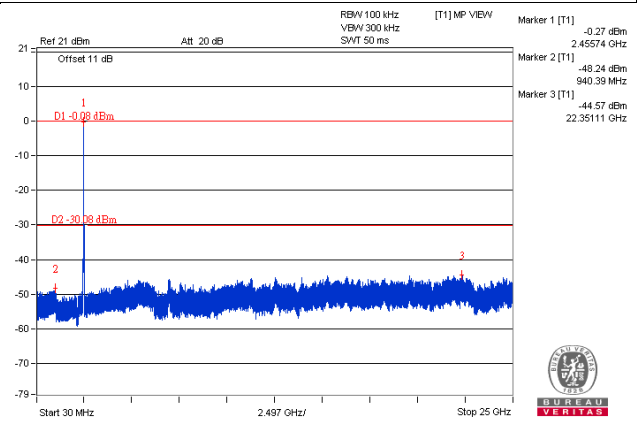
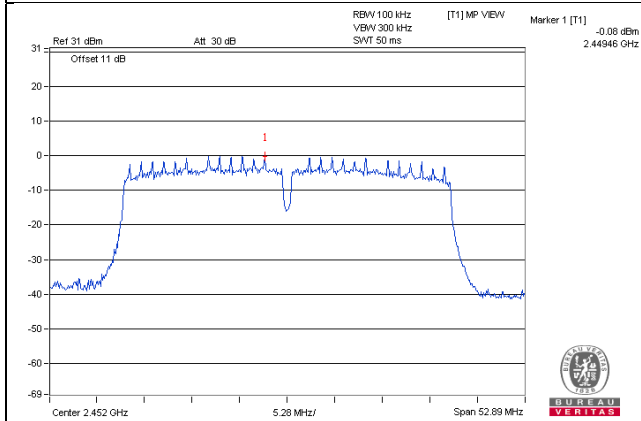

CH 3 Band edge

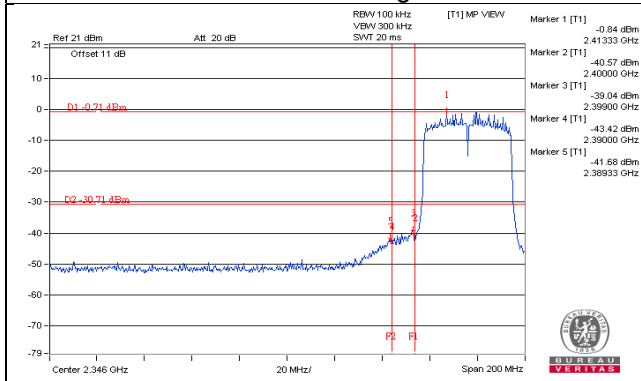

CH 9 Band edge

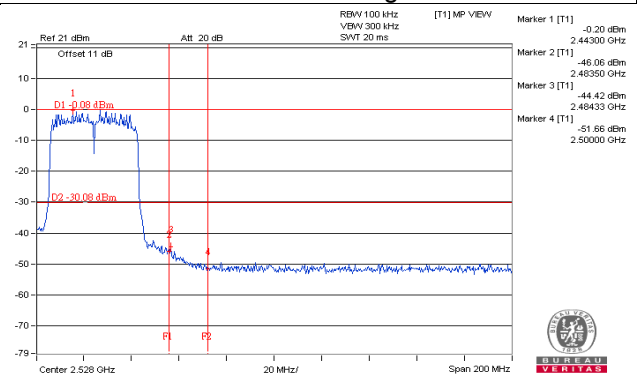

802.11n (HT40)_Chain 1

CH 3

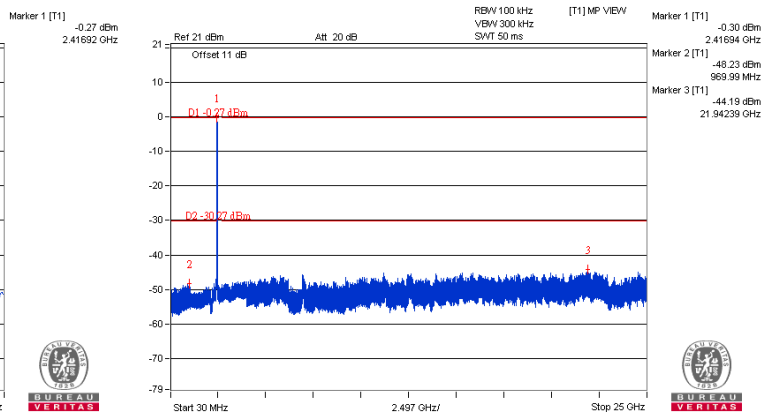
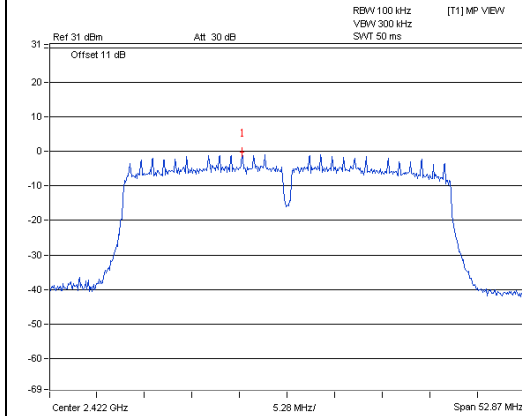

CH 6

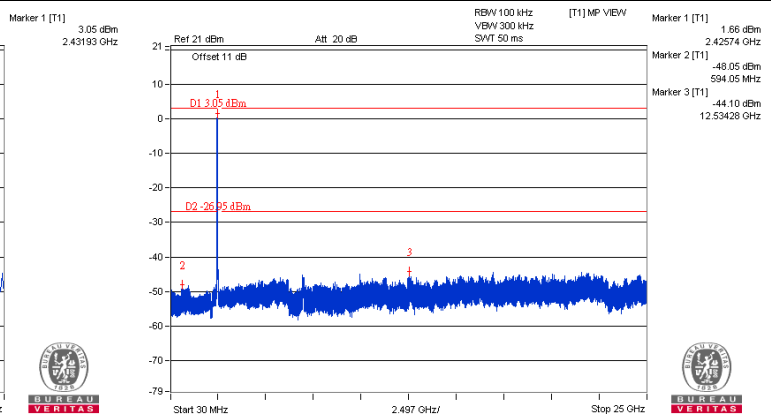
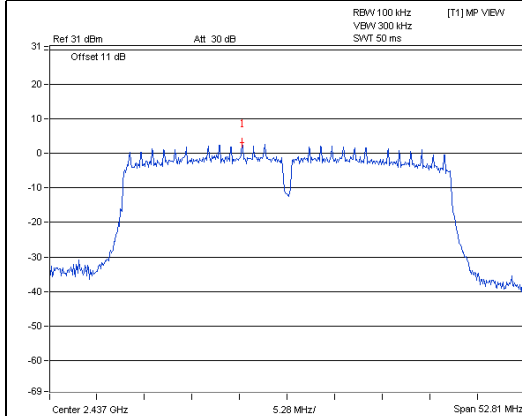

CH 9

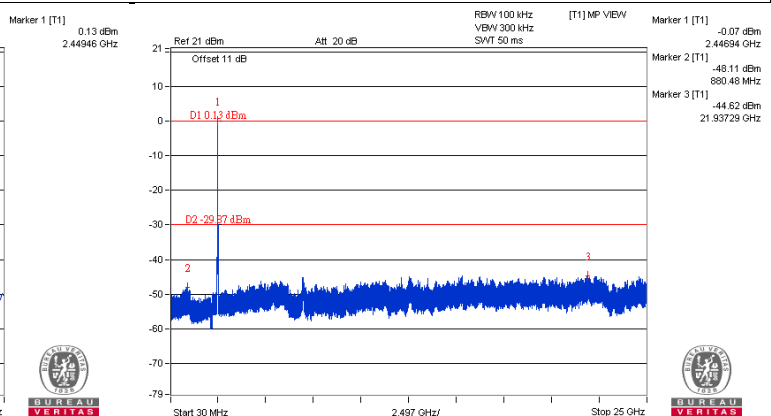
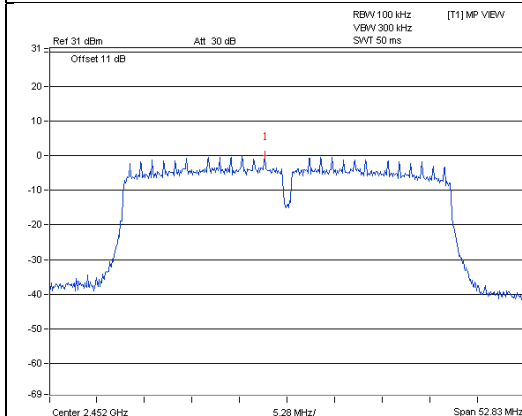

CH 3 Band edge

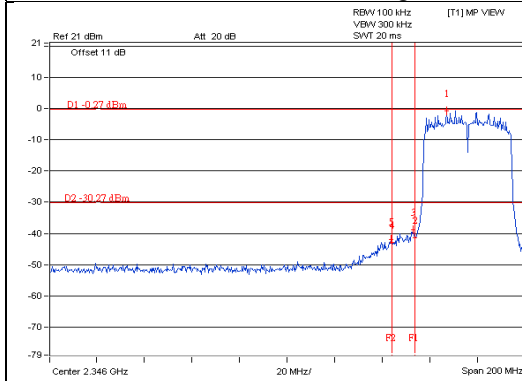

CH 9 Band edge

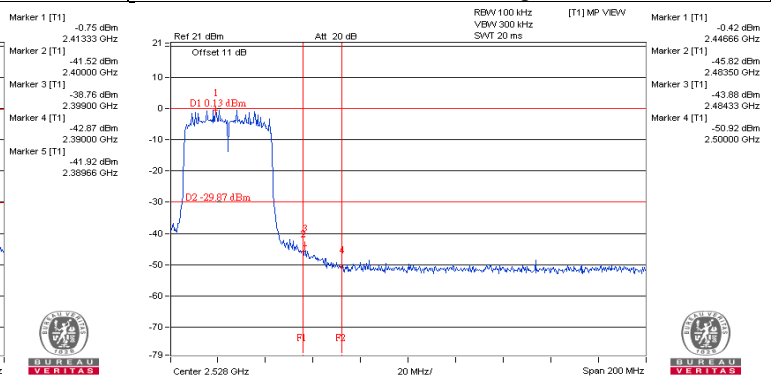

Radio 1: Beamforming Mode
802.11n (HT20)_Chain 0

CH 1

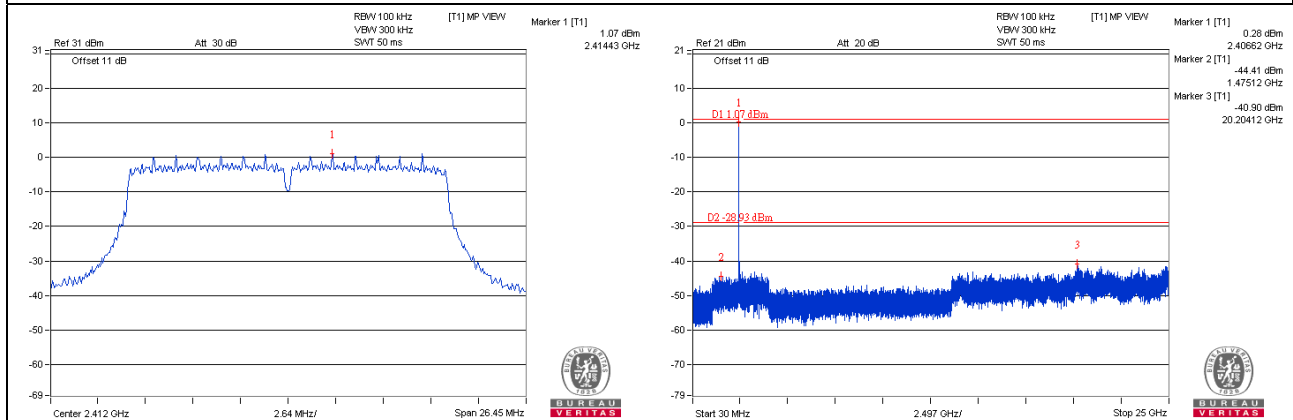

CH 6

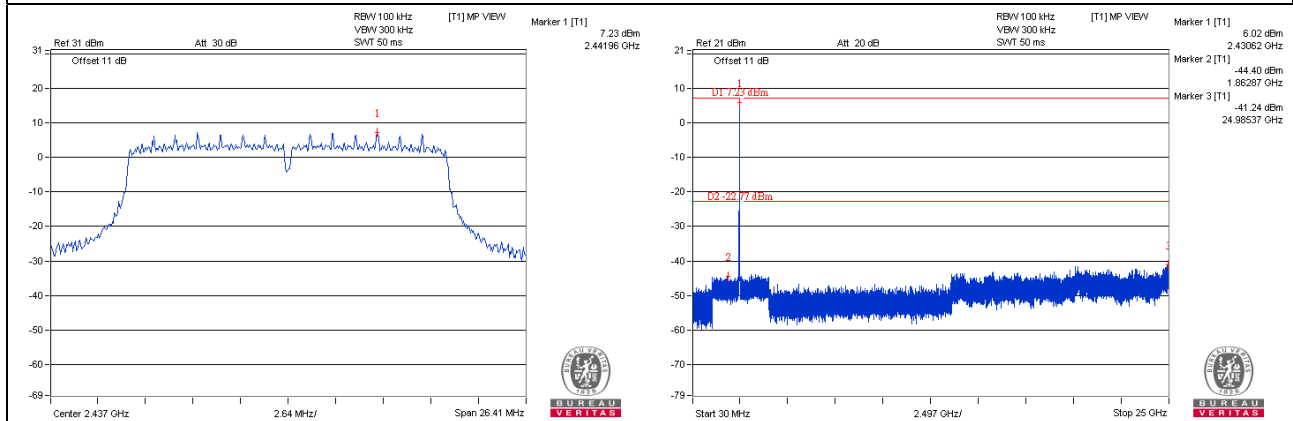

CH 11

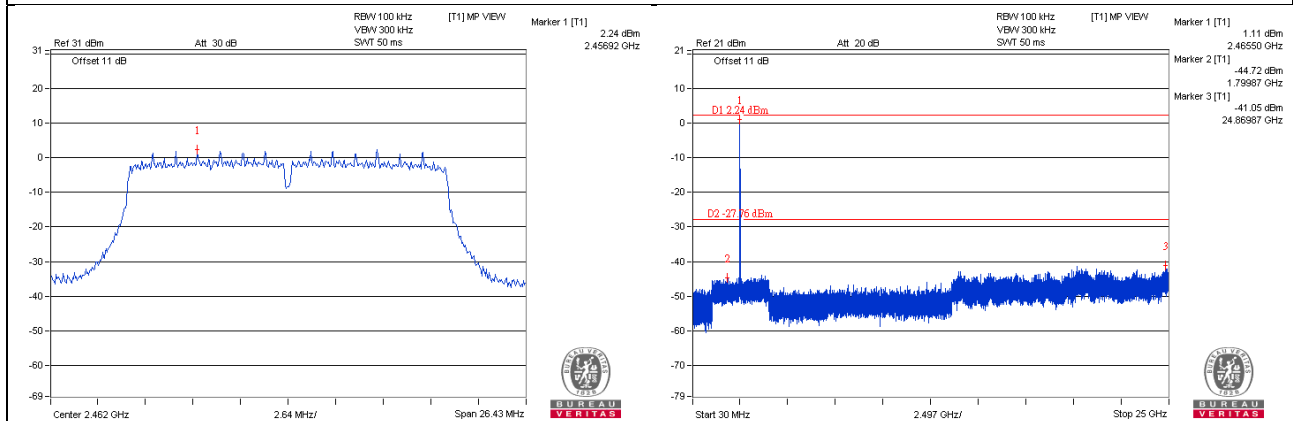

CH 1 Band edge

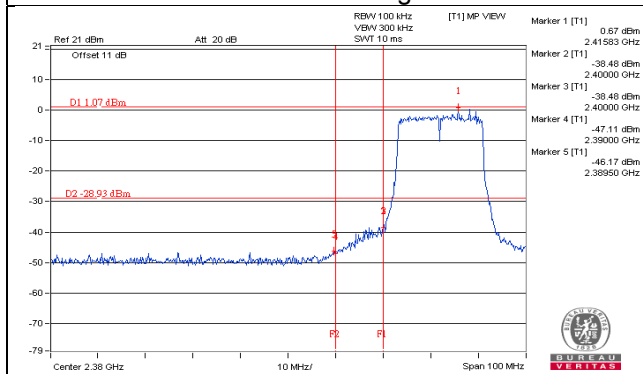

CH 11 Band edge

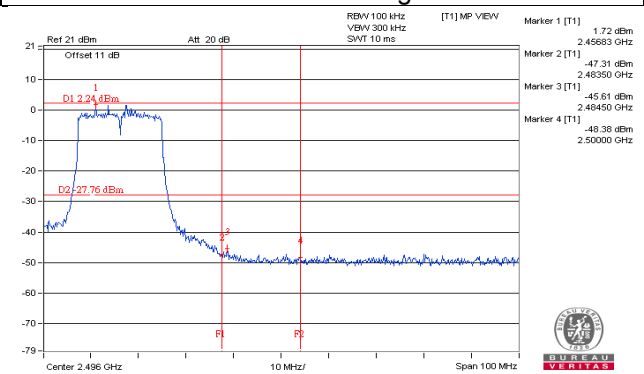

802.11n (HT20)_Chain 1

CH 1

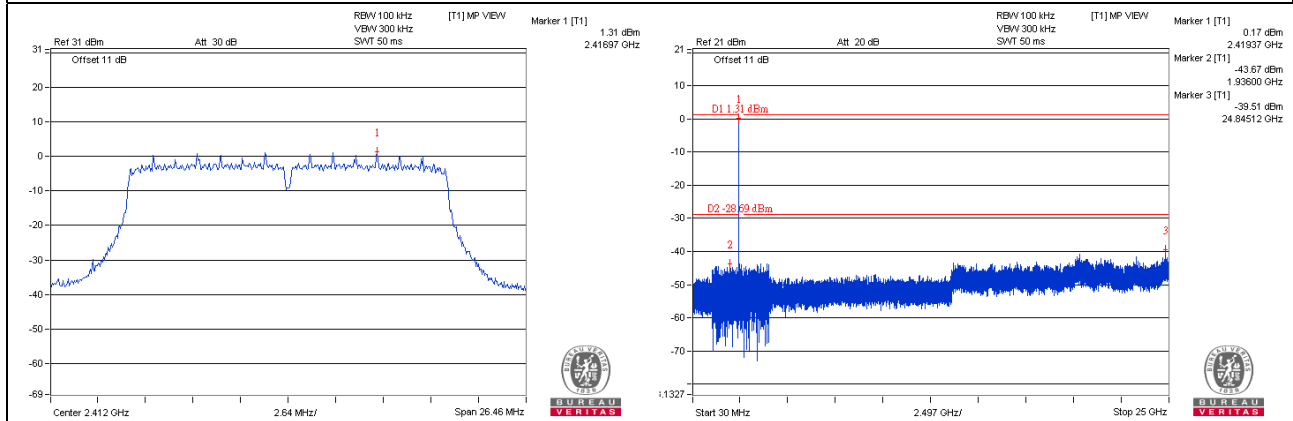

CH 6

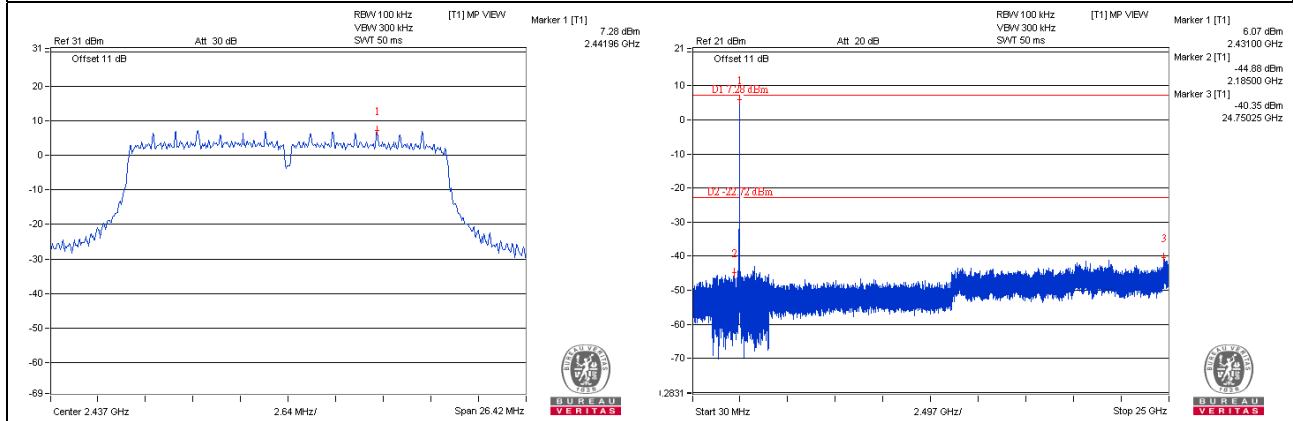

CH 11

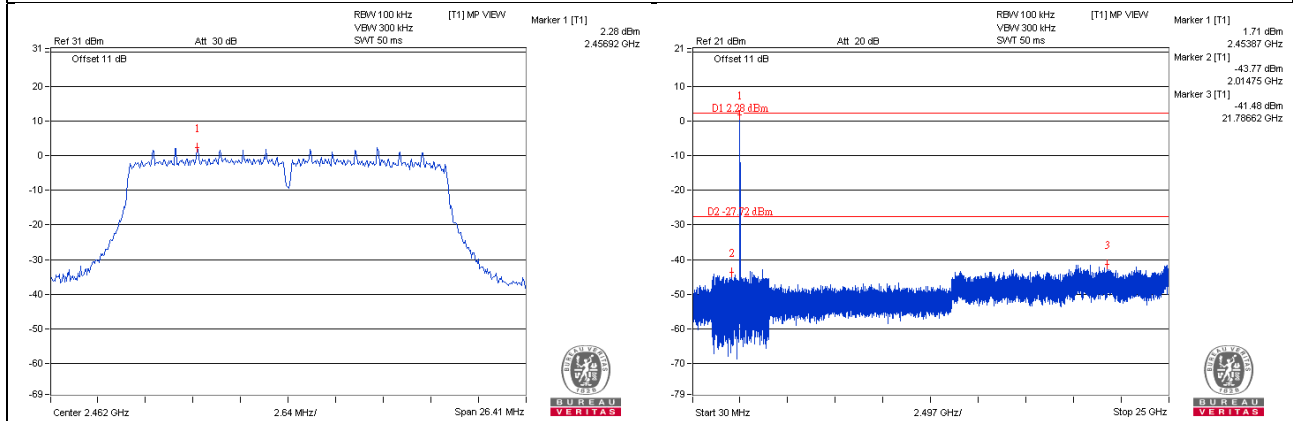

CH 1 Band edge

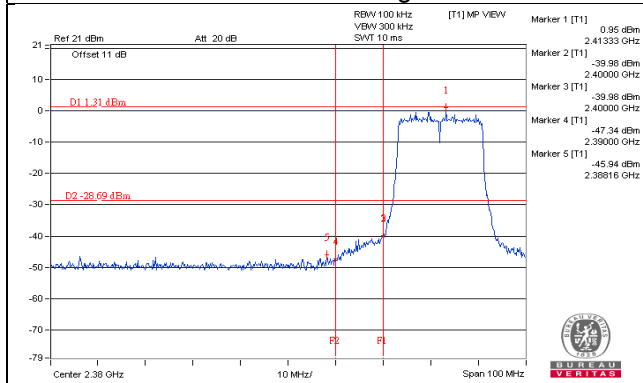

CH 11 Band edge

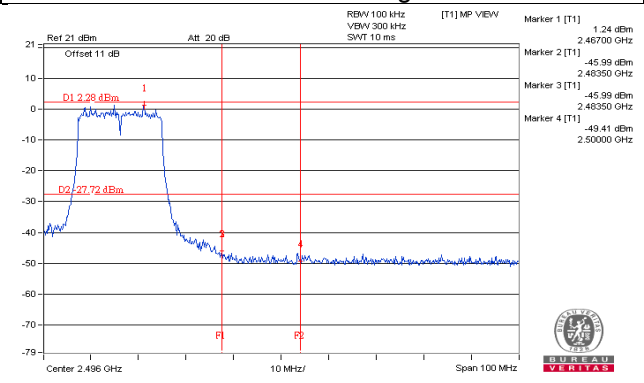

802.11n (HT40)_Chain 0

CH 3

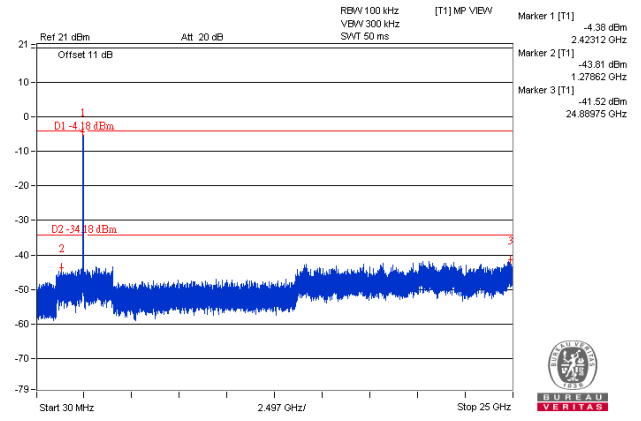
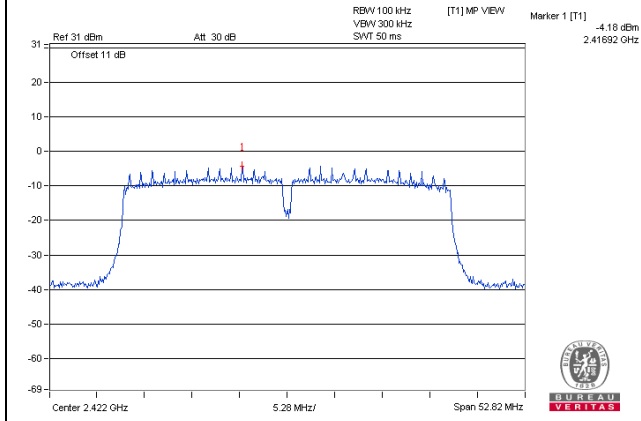

CH 6

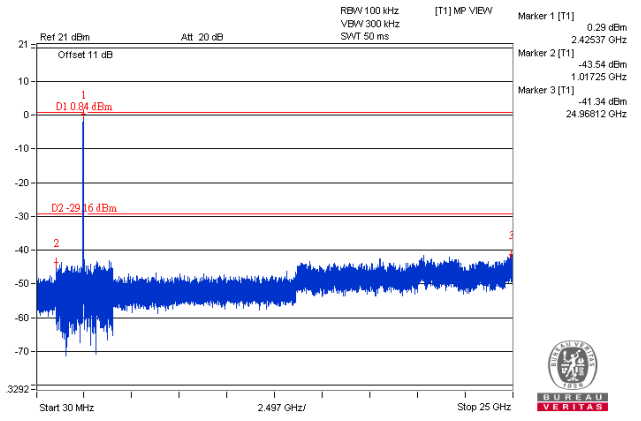
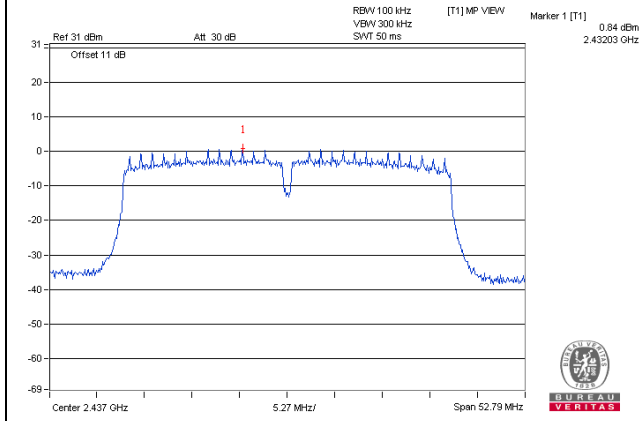

CH 9

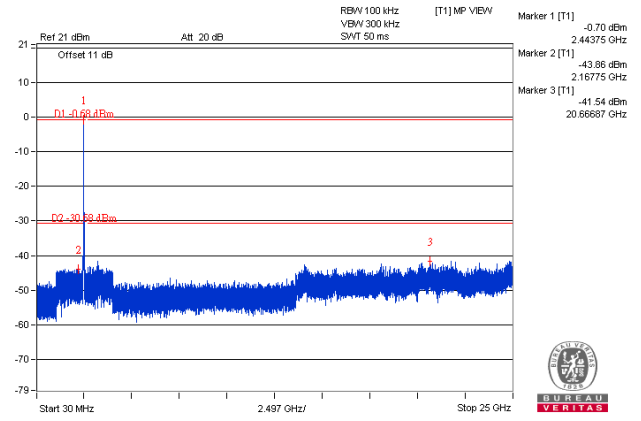
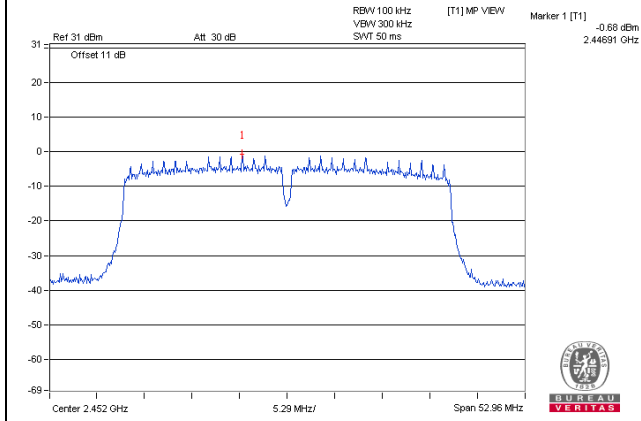

CH 3 Band edge

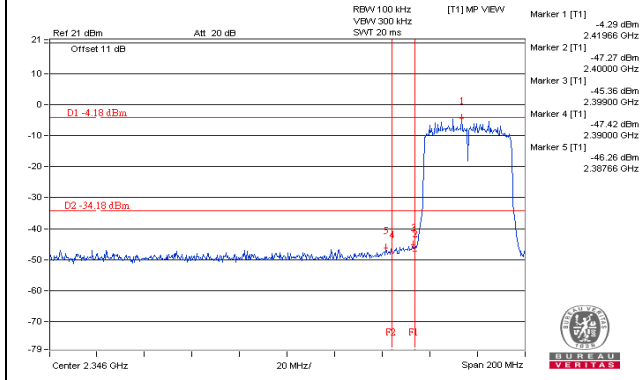

CH 9 Band edge

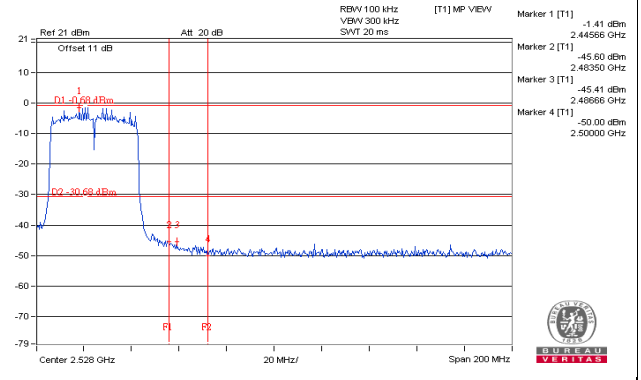

802.11n (HT40)_Chain 1

CH 3

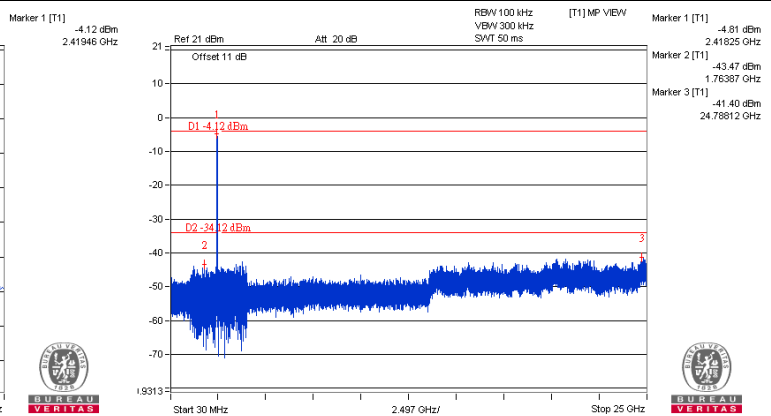
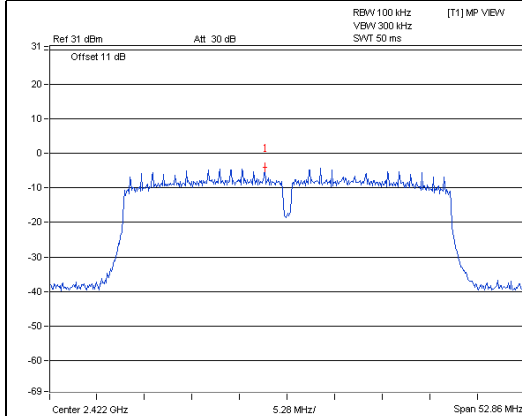

CH 6

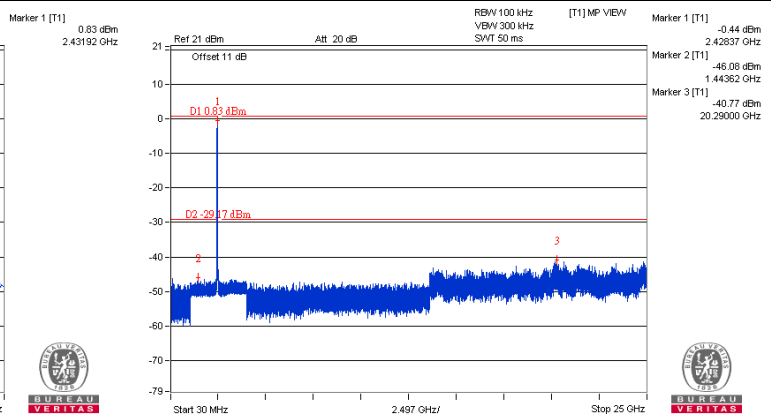
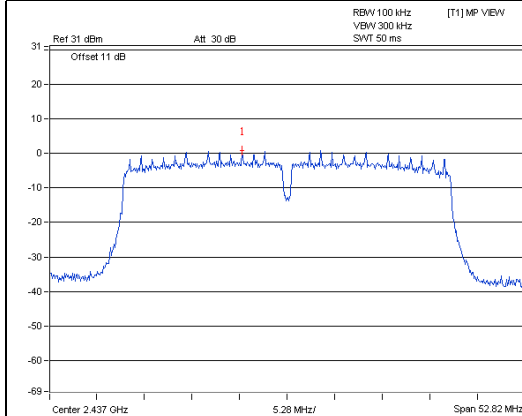

CH 9

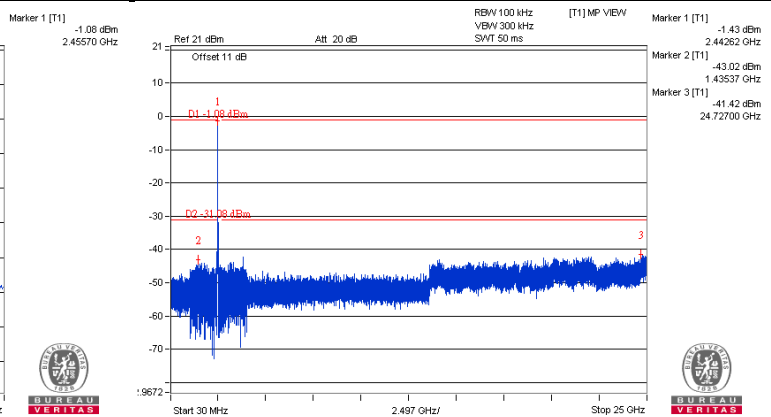
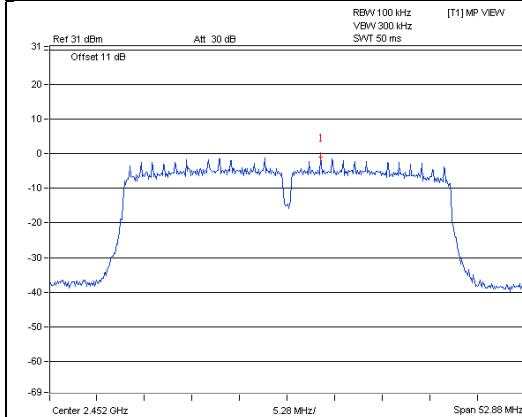

CH 3 Band edge

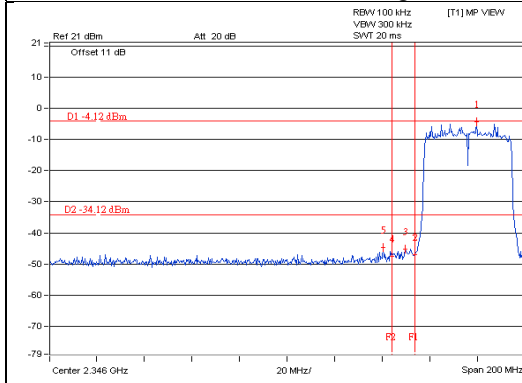

CH 9 Band edge

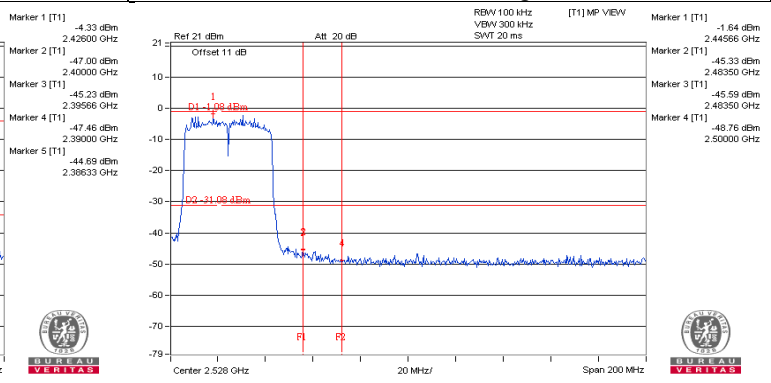

Radio 3: CDD Mode
802.11b

CH 1

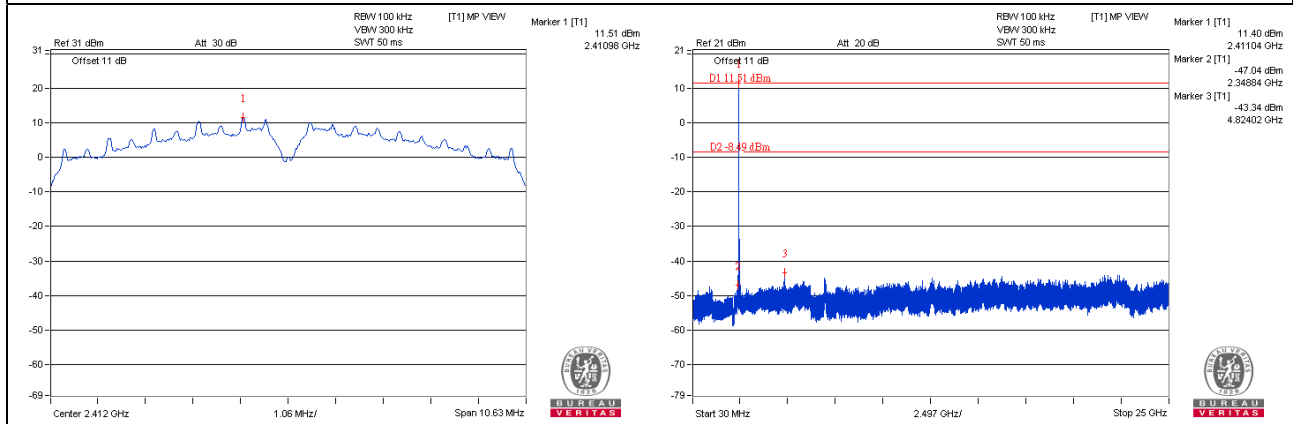

CH 6

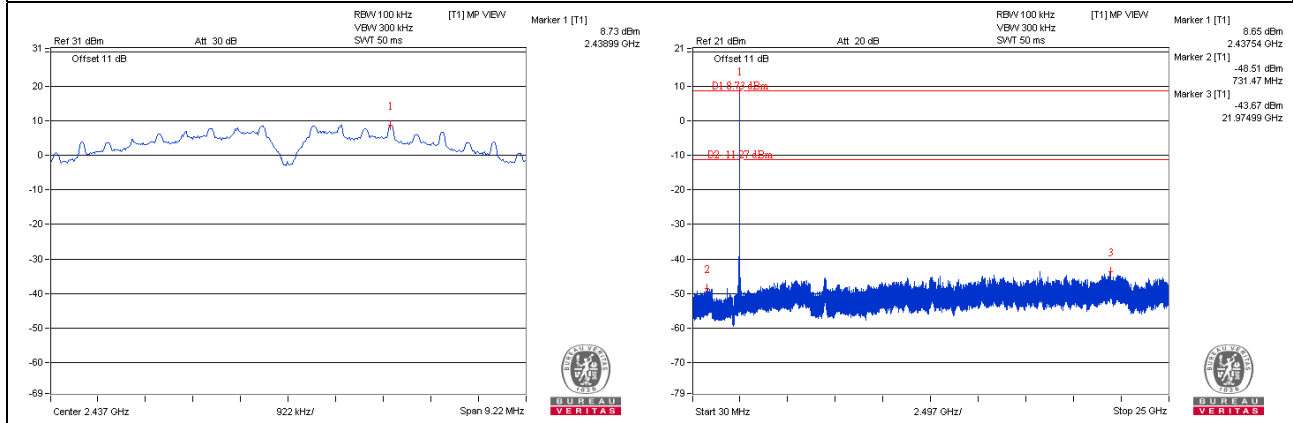

CH 11

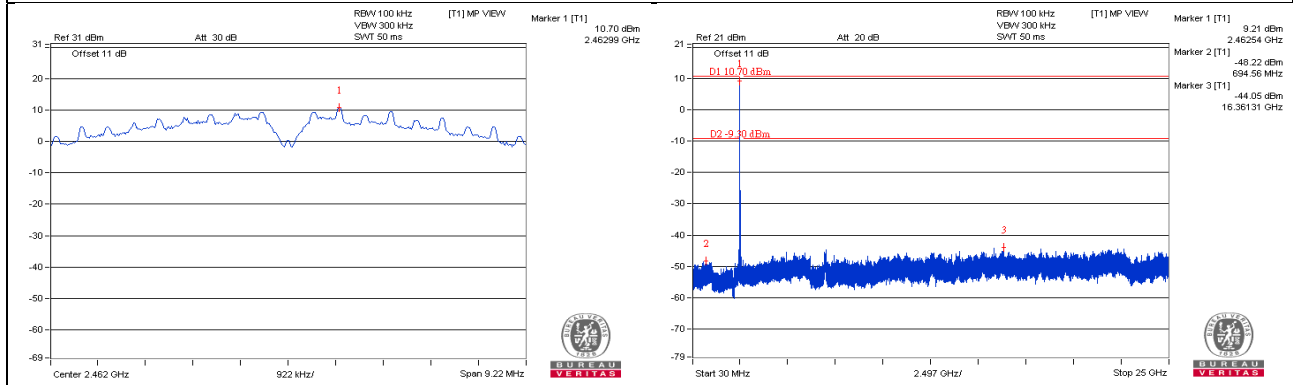

CH 1 Band edge

CH 11 Band edge

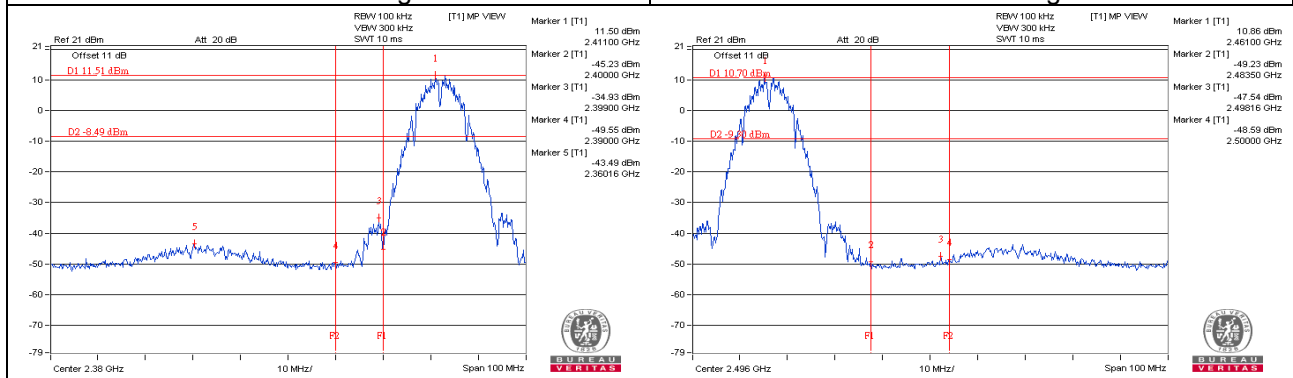

802.11g

CH 1

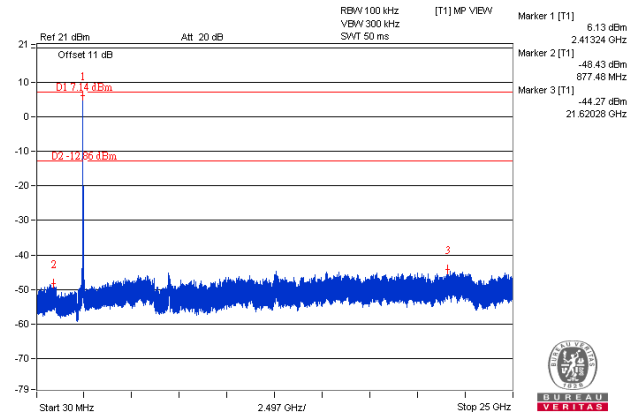
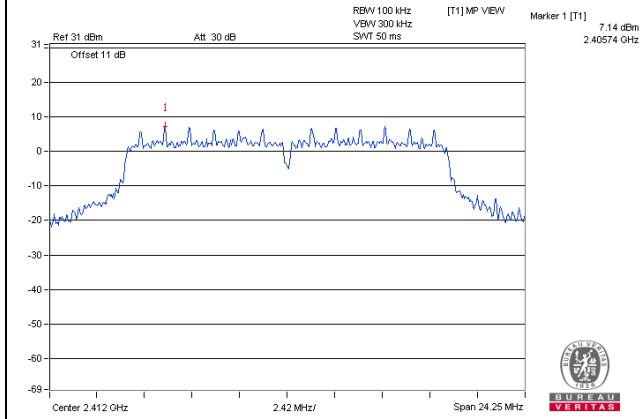

CH 6

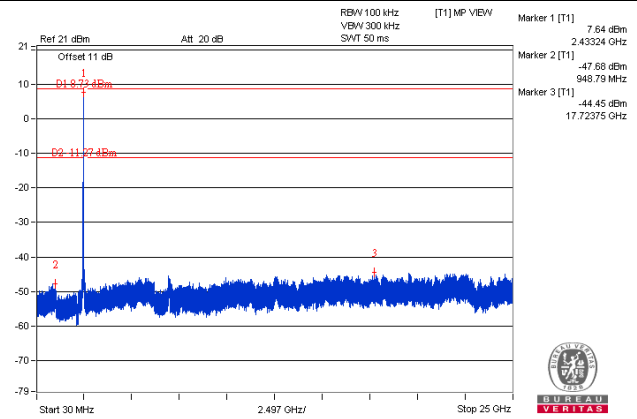
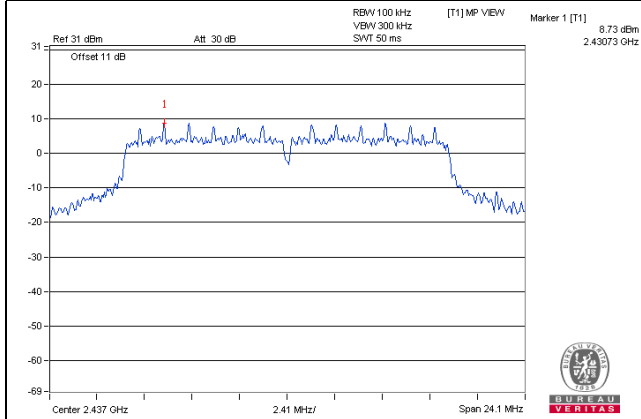

CH 11

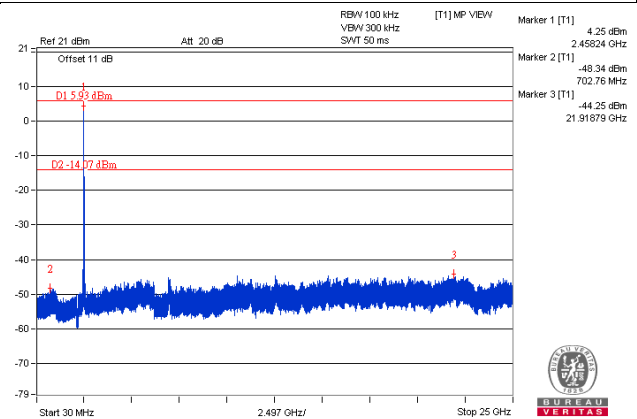
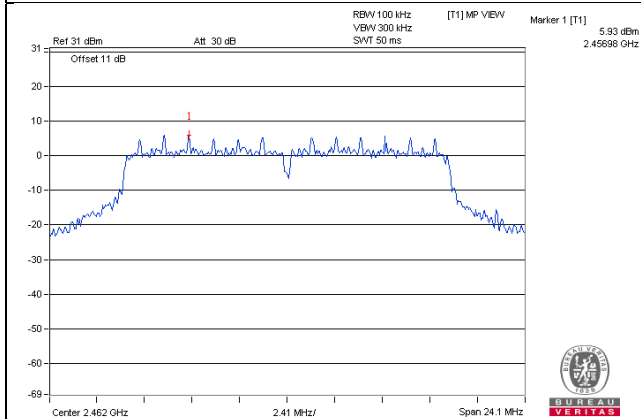

CH 1 Band edge

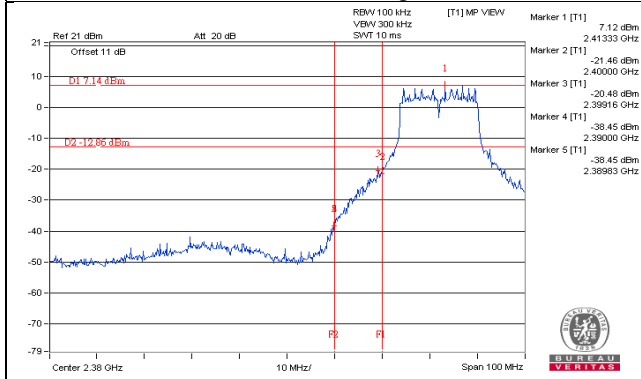

CH 11 Band edge

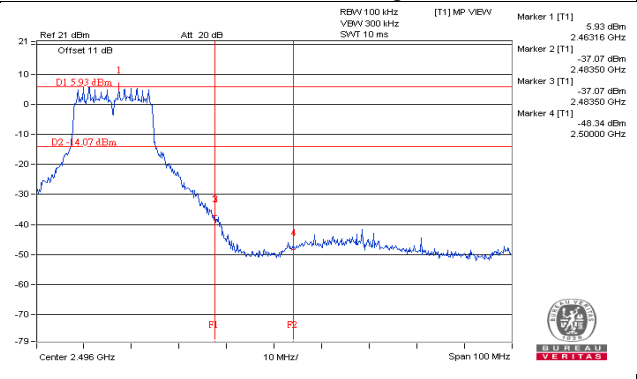

802.11n (HT20)

CH 1

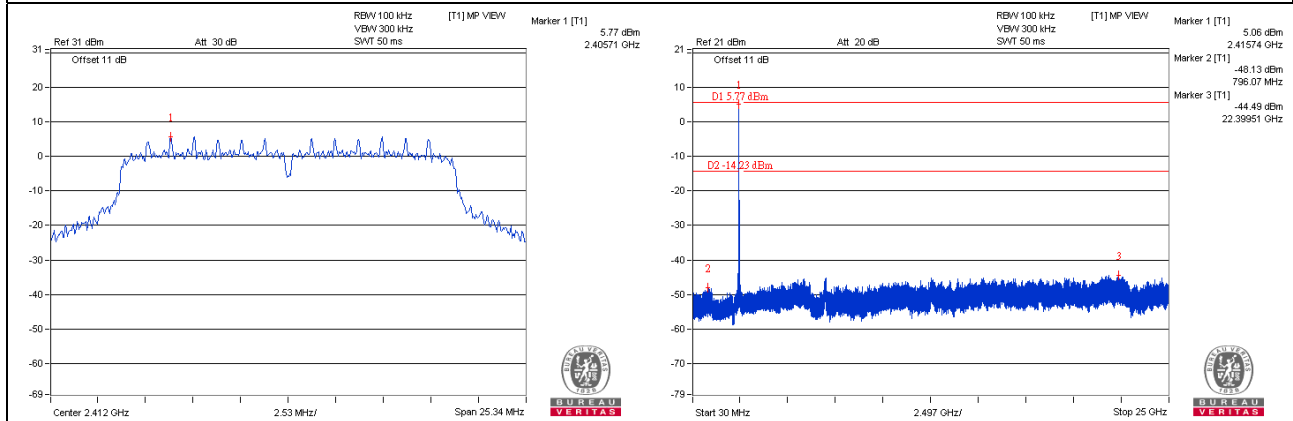

CH 6

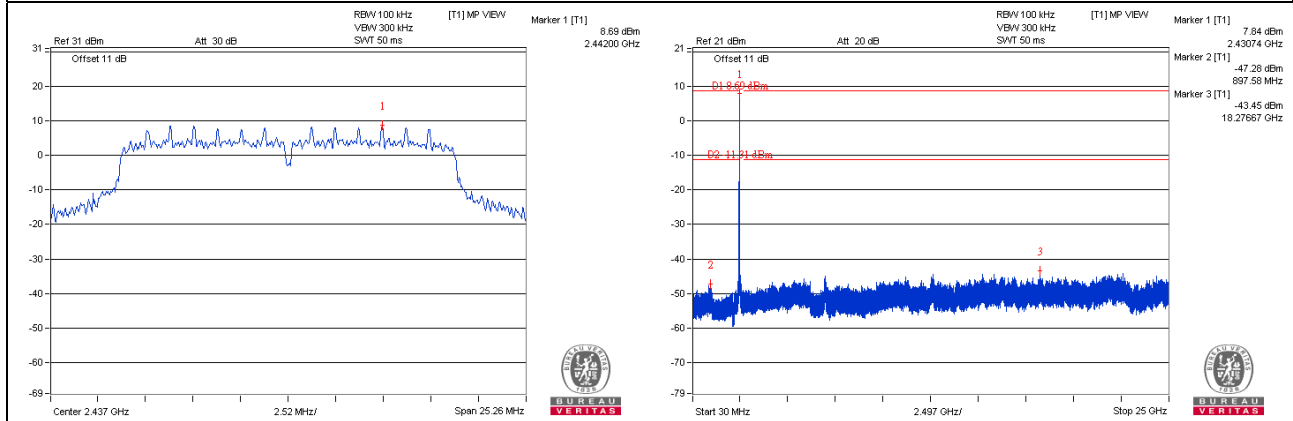

CH 11

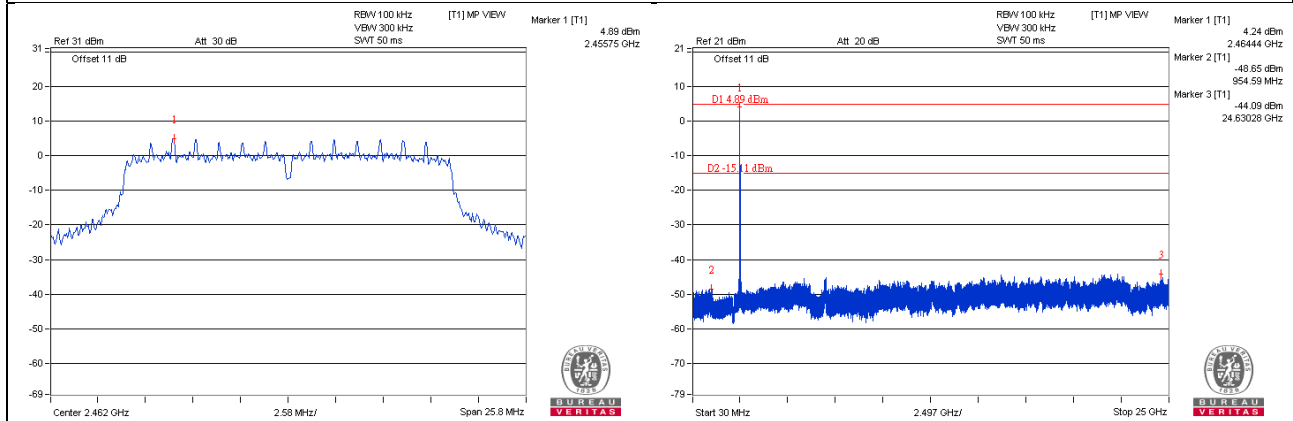

CH 1 Band edge

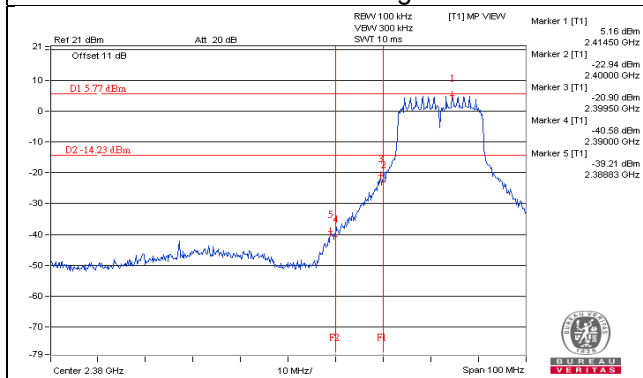

CH 11 Band edge

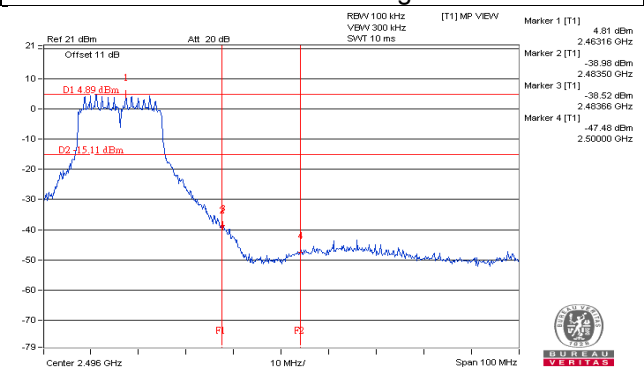

802.11n (HT40)

CH 3

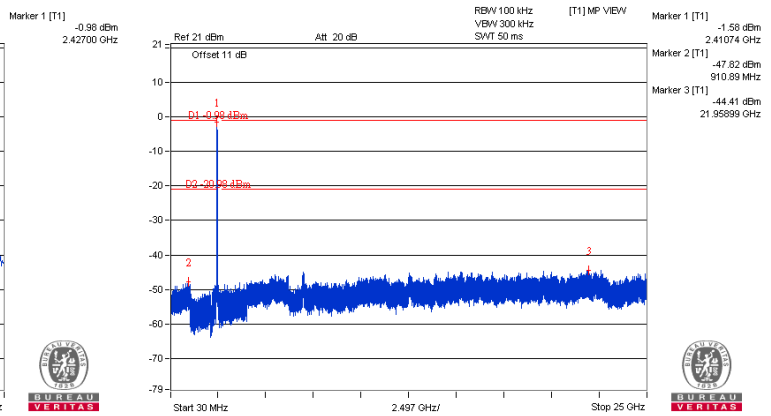
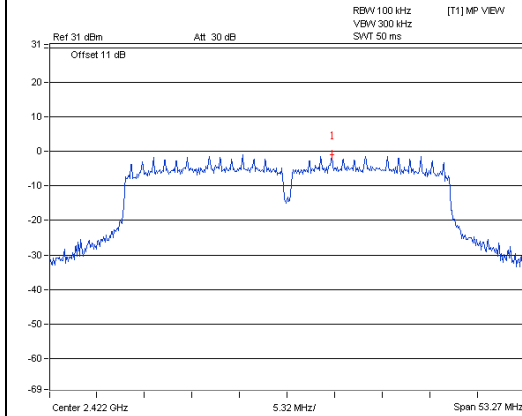

CH 6

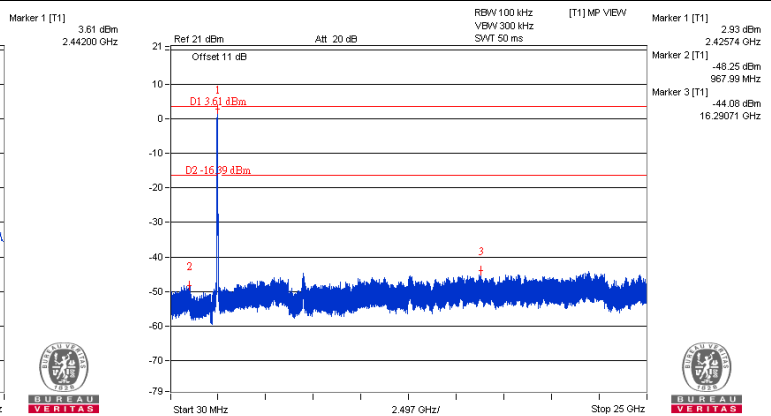
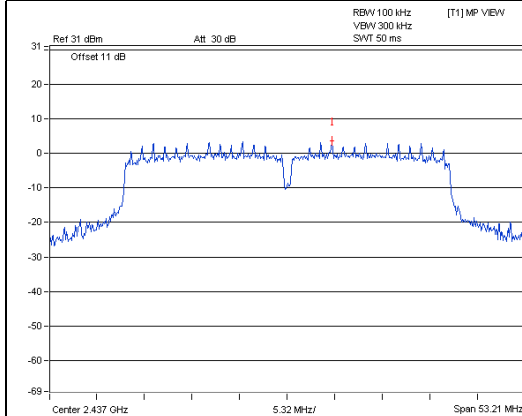

CH 9

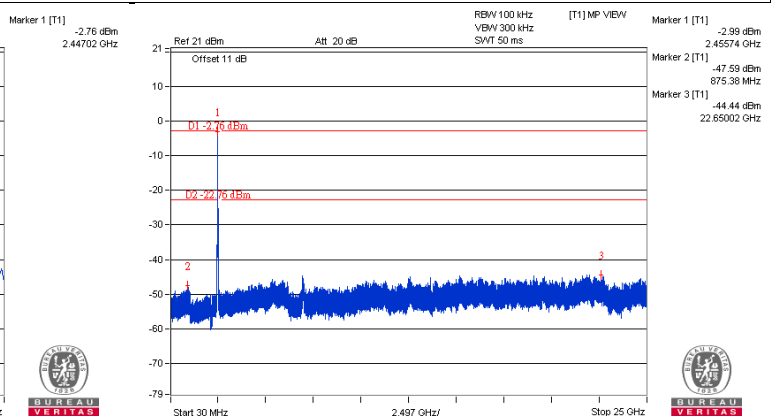
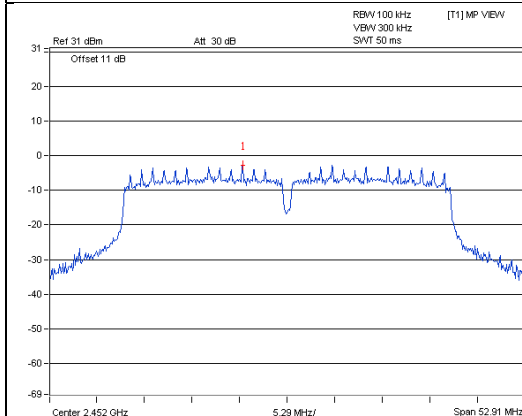

CH 3 Band edge

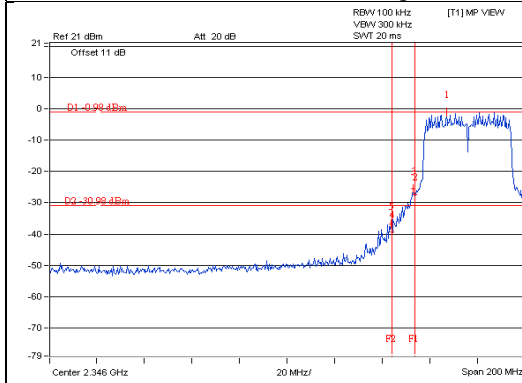

CH 9 Band edge

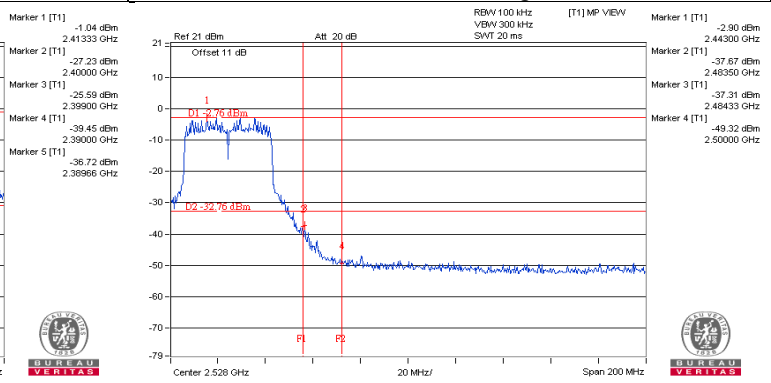

5 Pictures of Test Arrangements

Please refer to the attached file (Test Setup Photo).

Appendix – Information on the Testing Laboratories

We, Bureau Veritas Consumer Products Services (H.K.) Ltd., Taoyuan Branch, were founded in 1988 to provide our best service in EMC, Radio, Telecom and Safety consultation. Our laboratories are accredited and approved according to ISO/IEC 17025.

If you have any comments, please feel free to contact us at the following:

Linko EMC/RF Lab

Tel: 886-2-26052180

Fax: 886-2-26051924

Hsin Chu EMC/RF/Telecom Lab

Tel: 886-3-6668565

Fax: 886-3-6668323

Hwa Ya EMC/RF/Safety Lab

Tel: 886-3-3183232

Fax: 886-3-3270892

Email: service.adt@tw.bureauveritas.com

Web Site: www.bureauveritas-adt.com

The address and road map of all our labs can be found in our web site also.

--- END ---