

FCC Test Report

Report No.: RF160720C36

FCC ID: UDX-60051010

Test Model: MR30H-HW

Received Date: Jul. 11, 2016

Test Date: Jul. 11 ~ Aug. 31, 2016

Issued Date: Sep. 08, 2016

Applicant: Cisco Systems, Inc.

Address: 170 West Tasman Drive, San Jose, CA 95134

Issued By: Bureau Veritas Consumer Products Services (H.K.) Ltd., Taoyuan Branch

Lab Address: No. 47-2, 14th Ling, Chia Pau Vil., Lin Kou Dist., New Taipei City, Taiwan, R.O.C.

Test Location: No.19, Hwa Ya 2nd Rd., Wen Hwa Vil., Kwei Shan Dist., Taoyuan City 33383, TAIWAN (R.O.C.)



This report is for your exclusive use. Any copying or replication of this report to or for any other person or entity, or use of our name or trademark, is permitted only with our prior written permission. This report sets forth our findings solely with respect to the test samples identified herein. The results set forth in this report are not indicative or representative of the quality or characteristics of the lot from which a test sample was taken or any similar or identical product unless specifically and expressly noted. Our report includes all of the tests requested by you and the results thereof based upon the information that you provided to us. You have 60 days from date of issuance of this report to notify us of any material error or omission caused by our negligence, provided, however, that such notice shall be in writing and shall specifically address the issue you wish to raise. A failure to raise such issue within the prescribed time shall constitute your unqualified acceptance of the completeness of this report, the tests conducted and the correctness of the report contents. Unless specific mention, the uncertainty of measurement has been explicitly taken into account to declare the compliance or non-compliance to the specification. This report should not be used by the client to claim product certification, approval, or endorsement by TAF or any government agencies.

Table of Contents

Release Control Record	4
1 Certificate of Conformity	5
2 Summary of Test Results	6
2.1 Measurement Uncertainty.....	6
2.2 Modification Record.....	6
3 General Information	7
3.1 General Description of EUT.....	7
3.2 Description of Test Modes.....	9
3.2.1 Test Mode Applicability and Tested Channel Detail.....	10
3.3 Duty Cycle of Test Signal.....	12
3.4 Description of Support Units.....	15
3.4.1 Configuration of System under Test.....	15
3.5 General Description of Applied Standards.....	15
4 Test Types and Results	16
4.1 Radiated Emission and Bandedge Measurement.....	16
4.1.1 Limits of Radiated Emission and Bandedge Measurement.....	16
4.1.2 Test Instruments.....	17
4.1.3 Test Procedures.....	18
4.1.4 Deviation from Test Standard.....	18
4.1.5 Test Set Up.....	19
4.1.6 EUT Operating Conditions.....	19
4.1.7 Test Results.....	20
4.2 Conducted Emission Measurement.....	52
4.2.1 Limits of Conducted Emission Measurement.....	52
4.2.2 Test Instruments.....	52
4.2.3 Test Procedures.....	53
4.2.4 Deviation from Test Standard.....	53
4.2.5 Test Setup.....	53
4.2.6 EUT Operating Conditions.....	53
4.2.7 Test Results.....	54
4.3 6dB Bandwidth Measurement.....	58
4.3.1 Limits of 6dB Bandwidth Measurement.....	58
4.3.2 Test Setup.....	58
4.3.3 Test Instruments.....	58
4.3.4 Test Procedure.....	58
4.3.5 Deviation from Test Standard.....	58
4.3.6 EUT Operating Conditions.....	58
4.3.7 Test Result.....	59
4.4 Conducted Output Power Measurement.....	64
4.4.1 Limits of Conducted Output Power Measurement.....	64
4.4.2 Test Setup.....	64
4.4.3 Test Instruments.....	64
4.4.4 Test Procedures.....	64
4.4.5 Deviation from Test Standard.....	64
4.4.6 EUT Operating Conditions.....	64
4.4.7 Test Results.....	65
4.5 Power Spectral Density Measurement.....	69
4.5.1 Limits of Power Spectral Density Measurement.....	69
4.5.2 Test Setup.....	69
4.5.3 Test Instruments.....	69
4.5.4 Test Procedure.....	69
4.5.5 Deviation from Test Standard.....	70
4.5.6 EUT Operating Condition.....	70

4.5.7 Test Results	71
4.6 Conducted Out of Band Emission Measurement.....	78
4.6.1 Limits of Conducted Out of Band Emission Measurement	78
4.6.2 Test Setup.....	78
4.6.3 Test Instruments	78
4.6.4 Test Procedure	78
4.6.5 Deviation from Test Standard	79
4.6.6 EUT Operating Condition	79
4.6.7 Test Results	79
5 Pictures of Test Arrangements.....	96
Appendix – Information on the Testing Laboratories	97

Release Control Record

Issue No.	Description	Date Issued
RF160720C36	Original release	Sep. 08, 2016

1 Certificate of Conformity

Product: Wireless 802.11 abgn/ac indoor AP

Brand: Cisco

Test Model: MR30H-HW

Sample Status: Engineering sample

Applicant: Cisco Systems, Inc.

Test Date: Jul. 11 ~ Aug. 31, 2016

Standards: 47 CFR FCC Part 15, Subpart C (Section 15.247)
ANSI C63.10:2013

The above equipment has been tested by **Bureau Veritas Consumer Products Services (H.K.) Ltd., Taoyuan Branch**, and found compliance with the requirement of the above standards. The test record, data evaluation & Equipment Under Test (EUT) configurations represented herein are true and accurate accounts of the measurements of the sample's EMC characteristics under the conditions specified in this report.

Prepared by : Celine Chou , **Date:** Sep. 08, 2016
Celine Chou / Specialist

Approved by : Ken Liu , **Date:** Sep. 08, 2016
Ken Liu / Senior Manager

2 Summary of Test Results

47 CFR FCC Part 15, Subpart C (Section 15.247)			
FCC Clause	Test Item	Result	Remarks
15.207	AC Power Conducted Emission	Pass	Meet the requirement of limit. Minimum passing margin is -2.65dB at 0.55273MHz
15.205 / 15.209 / 15.247(d)	Radiated Emissions and Band Edge Measurement	Pass	Meet the requirement of limit. Minimum passing margin is -1.1dB at 2390.00MHz.
15.247(d)	Antenna Port Emission	Pass	Meet the requirement of limit.
15.247(a)(2)	6dB bandwidth	Pass	Meet the requirement of limit.
15.247(b)	Conducted power	Pass	Meet the requirement of limit.
15.247(e)	Power Spectral Density	Pass	Meet the requirement of limit.
15.203	Antenna Requirement	Pass	For PIFA antenna: Antenna connector is IPEX not a standard connector. For Chip antenna: No antenna connector is used.

2.1 Measurement Uncertainty

Where relevant, the following measurement uncertainty levels have been estimated for tests performed on the EUT as specified in CISPR 16-4-2:

Measurement	Frequency	Expanded Uncertainty (k=2) (\pm)
Conducted Emissions at mains ports	150kHz ~ 30MHz	2.44 dB
Radiated Emissions up to 1 GHz	30MHz ~ 200MHz	3.86 dB
	200MHz ~ 1000MHz	3.87 dB
Radiated Emissions above 1 GHz	1GHz ~ 18GHz	2.29 dB
	18GHz ~ 40GHz	2.29 dB

2.2 Modification Record

There were no modifications required for compliance.

3 General Information

3.1 General Description of EUT

Product	Wireless 802.11 abgn/ac indoor AP
Brand	Cisco
Test Model	MR30H-HW
Sample Status	Engineering sample
Power Supply Rating	48Vdc
Modulation Type	CCK, DQPSK, DBPSK for DSSS 64QAM, 16QAM, QPSK, BPSK for OFDM
Modulation Technology	DSSS, OFDM
Transfer Rate	802.11b: 11.0/ 5.5/ 2.0/ 1.0Mbps 802.11g: 54.0/ 48.0/ 36.0/ 24.0/ 18.0/ 12.0/ 9.0/ 6.0Mbps 802.11n: up to 300Mbps
Operating Frequency	2412 ~ 2462MHz
Number of Channel	11 for 802.11b, 802.11g, 802.11n (HT20) 7 for 802.11n (HT40)
Output Power	Radio 1: CDD Mode: 235.200mW Beamforming Mode: 175.477mW Radio 3: CDD Mode: 246.037mW
Antenna Type	Refer to note
Antenna Connector	Refer to note
Accessory Device	NA
Data Cable Supplied	NA

Note:

- The EUT incorporates a MIMO function. Physically, the EUT provides 2 completed transmitters and 2 receivers.

Modulation Mode	TX Function	Beamforming	Remark
802.11b	2TX	Not Support	Radio 1
802.11g	2TX	Not Support	
802.11n (HT20)	2TX	Support	
802.11n (HT40)	2TX	Support	
802.11b	1TX	Not Support	Radio 3
802.11g	1TX	Not Support	
802.11n (HT20)	1TX	Not Support	
802.11n (HT40)	1TX	Not Support	

* For 2.4GHz band, CDD mode is the worst case for final radiated emission below 1GHz and power line conducted emission tests after pretesting CDD mode and beamforming mode.

2. The EUT with follow antennas gain is listed as table below.

No.	Type	Connector	Gain(dBi)		Remark
			2.4GHz	5GHz	
1	PIFA	IPEX	3.99	4.84	2.4G for Radio 1 (WLAN)
2	PIFA	IPEX	3.42	4.87	5G for Radio 2 (WLAN)
3	Chip	NA	2.27	5.18	Radio 3 (WLAN)
4	Chip	NA	2.66	-	Radio 4 (BT LE)

3. The EUT consumes power from the following POE. (Support unit only)

POE	
Brand	EnGenius
Model	EPE-48GR
Power Rating	48Vdc, 0.8A, 38.4W Max

Adapter for POE	
Brand	Powertron Electronics Corp.
Model	PA1040-480IB080
Input Power	100-240Vac, 50-60Hz, 1.5A
Output Power	48Vdc, 0.8A, 38.4W Max
Power Line	1.55m cable with one core attached on adapter

4. 2.4GHz, 5GHz and BT LE technology can transmit at same time.

5. Spurious emission of the simultaneous operation (2.4GHz, 5GHz and BT LE) has been evaluated and no non-compliance was found.

3.2 Description of Test Modes

11 channels are provided for 802.11b, 802.11g and 802.11n (HT20):

Channel	Frequency	Channel	Frequency
1	2412MHz	7	2442MHz
2	2417MHz	8	2447MHz
3	2422MHz	9	2452MHz
4	2427MHz	10	2457MHz
5	2432MHz	11	2462MHz
6	2437MHz		

7 channels are provided for 802.11n (HT40):

Channel	Frequency	Channel	Frequency
3	2422MHz	7	2442MHz
4	2427MHz	8	2447MHz
5	2432MHz	9	2452MHz
6	2437MHz		

3.2.1 Test Mode Applicability and Tested Channel Detail

EUT CONFIGURE MODE	APPLICABLE TO				DESCRIPTION
	RE≥1G	RE<1G	PLC	APCM	
-	√	√	√	√	-

Where **RE≥1G**: Radiated Emission above 1GHz & Bandedge Measurement
RE<1G: Radiated Emission below 1GHz
PLC: Power Line Conducted Emission
APCM: Antenna Port Conducted Measurement

Note: The EUT had been pre-tested on the positioned of each 3 axis. The worst case was found when positioned on **Z-plane**.

Radiated Emission Test (Above 1GHz):

- Pre-Scan has been conducted to determine the worst-case mode from all possible combinations between available modulations, data rates and antenna ports (if EUT with antenna diversity architecture).
- Following channel(s) was (were) selected for the final test as listed below.

EUT CONFIGURE MODE	MODE	AVAILABLE CHANNEL	TESTED CHANNEL	MODULATION TECHNOLOGY	MODULATION TYPE	DATA RATE (Mbps)	REMARK
-	802.11b	1 to 11	1, 6, 11	DSSS	DBPSK	1.0	Radio 1 (2TX)
		1 to 11	1, 6, 11	DSSS	DBPSK	1.0	Radio 3 (1TX)
-	802.11g	1 to 11	1, 6, 11	OFDM	BPSK	6.0	Radio 1 (2TX)
		1 to 11	1, 6, 11	OFDM	BPSK	6.0	Radio 3 (1TX)
-	802.11n (HT20)	1 to 11	1, 6, 11	OFDM	BPSK	6.5	Radio 1 (2TX)
		1 to 11	1, 6, 11	OFDM	BPSK	6.5	Radio 3 (1TX)
-	802.11n (HT40)	3 to 9	3, 6, 9	OFDM	BPSK	13.5	Radio 1 (2TX)
		3 to 9	3, 6, 9	OFDM	BPSK	13.5	Radio 3 (1TX)

Radiated Emission Test (Below 1GHz):

- Pre-Scan has been conducted to determine the worst-case mode from all possible combinations between available modulations, data rates and antenna ports (if EUT with antenna diversity architecture).
- Following channel(s) was (were) selected for the final test as listed below.

EUT CONFIGURE MODE	MODE	AVAILABLE CHANNEL	TESTED CHANNEL	MODULATION TECHNOLOGY	MODULATION TYPE	DATA RATE (Mbps)	REMARK
-	802.11b	1 to 11	1	DSSS	DBPSK	1.0	Radio 1 (2TX)
		1 to 11	1	DSSS	DBPSK	1.0	Radio 3 (1TX)

Power Line Conducted Emission Test:

- Pre-Scan has been conducted to determine the worst-case mode from all possible combinations between available modulations, data rates and antenna ports (if EUT with antenna diversity architecture).
- Following channel(s) was (were) selected for the final test as listed below.

EUT CONFIGURE MODE	MODE	AVAILABLE CHANNEL	TESTED CHANNEL	MODULATION TECHNOLOGY	MODULATION TYPE	DATA RATE (Mbps)	REMARK
-	802.11b	1 to 11	1	DSSS	DBPSK	1.0	Radio 1 (2TX)
		1 to 11	1	DSSS	DBPSK	1.0	Radio 3 (1TX)

Antenna Port Conducted Measurement:

- This item includes all test value of each mode, but only includes spectrum plot of worst value of each mode.
- Pre-Scan has been conducted to determine the worst-case mode from all possible combinations between available modulations, data rates and antenna ports (if EUT with antenna diversity architecture).
- Following channel(s) was (were) selected for the final test as listed below.

EUT CONFIGURE MODE	MODE	AVAILABLE CHANNEL	TESTED CHANNEL	MODULATION TECHNOLOGY	MODULATION TYPE	DATA RATE (Mbps)	REMARK
-	802.11b	1 to 11	1, 6, 11	DSSS	DBPSK	1.0	Radio 1 (2TX)
		1 to 11	1, 6, 11	DSSS	DBPSK	1.0	Radio 3 (1TX)
-	802.11g	1 to 11	1, 6, 11	OFDM	BPSK	6.0	Radio 1 (2TX)
		1 to 11	1, 6, 11	OFDM	BPSK	6.0	Radio 3 (1TX)
-	802.11n (HT20)	1 to 11	1, 6, 11	OFDM	BPSK	6.5	Radio 1 (2TX)
		1 to 11	1, 6, 11	OFDM	BPSK	6.5	Radio 3 (1TX)
-	802.11n (HT40)	3 to 9	3, 6, 9	OFDM	BPSK	13.5	Radio 1 (2TX)
		3 to 9	3, 6, 9	OFDM	BPSK	13.5	Radio 3 (1TX)

Test Condition:

APPLICABLE TO	ENVIRONMENTAL CONDITIONS	INPUT POWER	TESTED BY
RE≥1G	19deg. C, 70%RH	48Vdc	James Yang
RE<1G	19deg. C, 70%RH	48Vdc	Jones Chang
PLC	20deg. C, 71%RH	48Vdc	Jones Chang
APCM	25deg. C, 60%RH	48Vdc	Antony Lee

3.3 Duty Cycle of Test Signal

Radio 1: CDD Mode

802.11b, 802.11n (HT20): Duty cycle of test signal is > 98%, duty factor is not required.

802.11g, 802.11n (HT40): Duty cycle of test signal is < 98%, duty factor shall be considered.

802.11b: Duty cycle = $12.208/12.320 = 0.991$

802.11g: Duty cycle = $2.017/2.115 = 0.954$, Duty factor = $10 * \log(1/0.954) = 0.21$

802.11n (HT20): Duty cycle = $4.949/5.050 = 0.980$

802.11n (HT40): Duty cycle = $2.397/2.497 = 0.960$, Duty factor = $10 * \log(1/0.960) = 0.18$

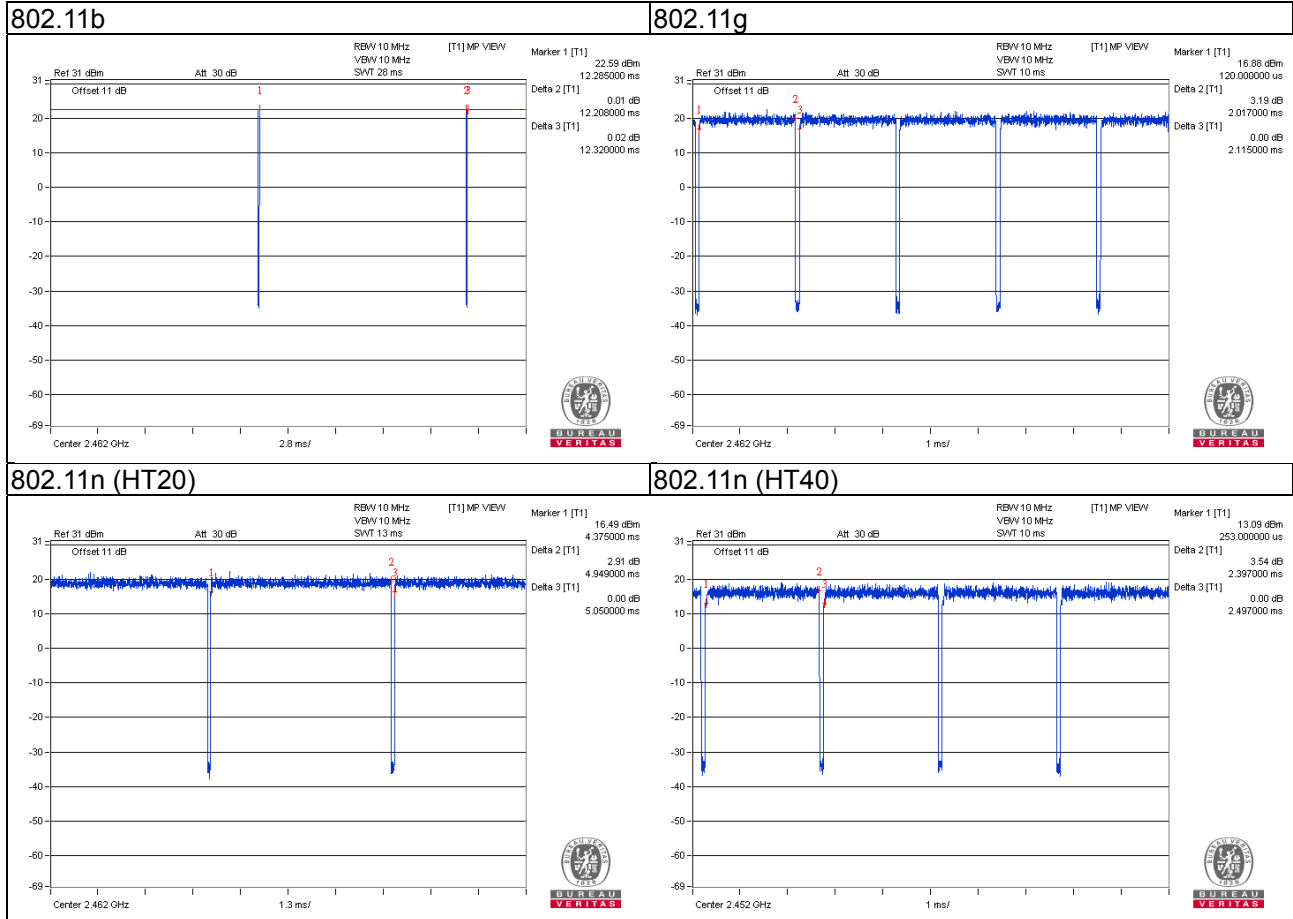

Radio 1: Beamforming Mode

802.11n (HT20): Duty cycle of test signal is > 98%, duty factor is not required.

802.11n (HT40): Duty cycle of test signal is < 98%, duty factor shall be considered.

802.11n (HT40): Duty cycle = $2.425/2.530 = 0.958$, Duty factor = $10 * \log(1/0.958) = 0.18$

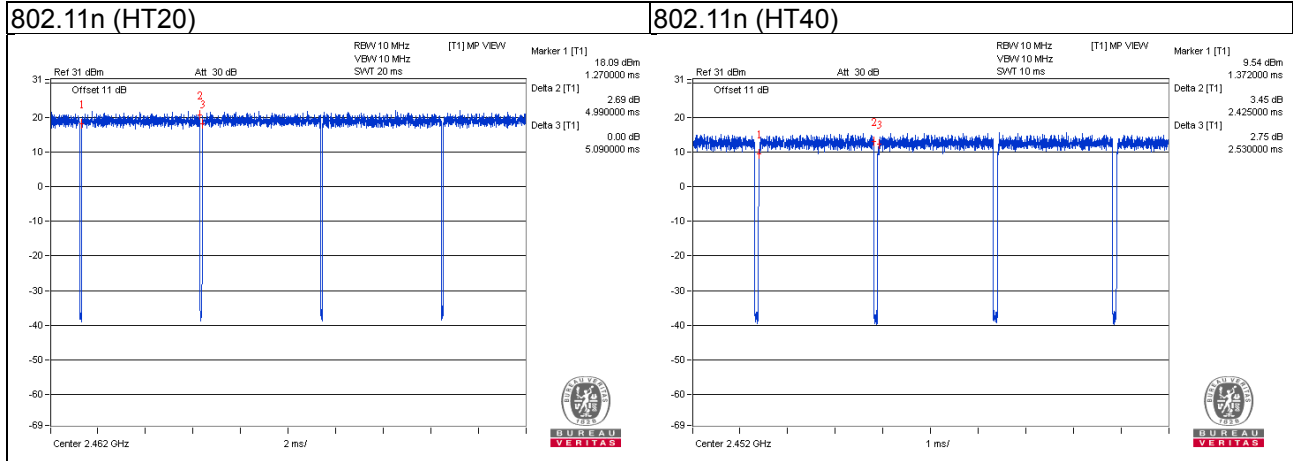

Radio 3: CDD Mode

802.11b: Duty cycle of test signal is > 98%.

802.11g, 802.11n (HT20), 802.11n (HT40): Duty cycle of test signal is < 98%.

802.11g: Duty cycle = $2.017/2.117 = 0.953$, Duty factor = $10 * \log(1/0.953) = 0.21$

802.11n (HT20): Duty cycle = $1.878/1.963 = 0.957$, Duty factor = $10 * \log(1/0.957) = 0.19$

802.11n (HT40): Duty cycle = $0.920/1.020 = 0.902$, Duty factor = $10 * \log(1/0.902) = 0.45$

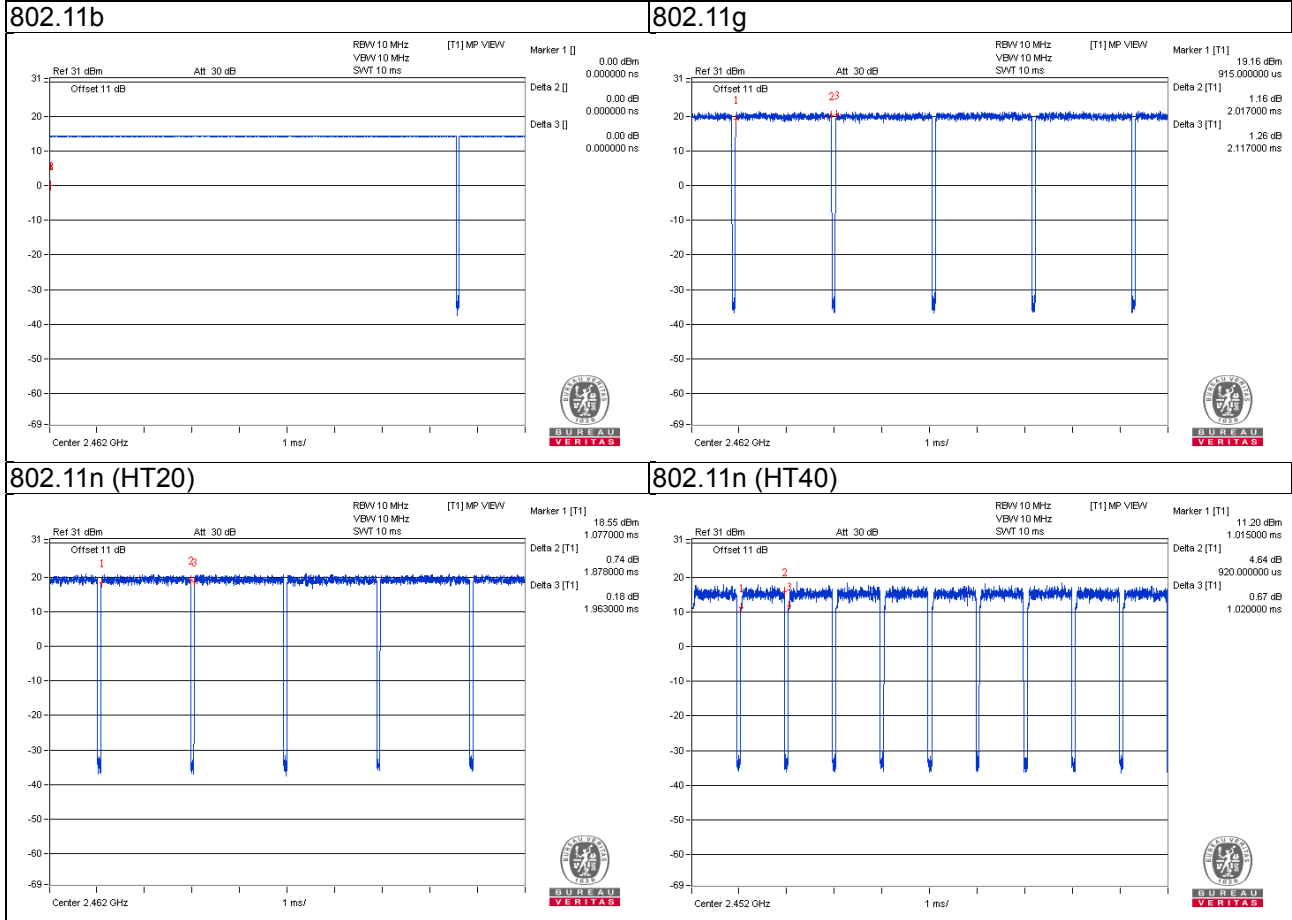

3.4 Description of Support Units

The EUT has been tested as an independent unit together with other necessary accessories or support units. The following support units or accessories were used to form a representative test configuration during the tests.

ID	Product	Brand	Model No.	Serial No.	FCC ID	Remarks
A.	Load	N/A	N/A	N/A	N/A	-
B.	POE	EnGenius	EPE-48GR	N/A	N/A	Provided by client
C.	Notebook	DELL	Latitude E6420	HPFC5Q1	FCC DoC Approved	-

Note:

1. All power cords of the above support units are non-shielded (1.8m).
2. Items B and C acted as communication partners to transfer data.

ID	Descriptions	Qty.	Length (m)	Shielding (Yes/No)	Cores (Qty.)	Remarks
1.	RJ45, Cat5e	4	1.8	N	0	-
2.	RJ45, Cat5e	1	3	N	0	-
3.	RJ45, Cat5e	1	1.8	N	0	-

3.4.1 Configuration of System under Test

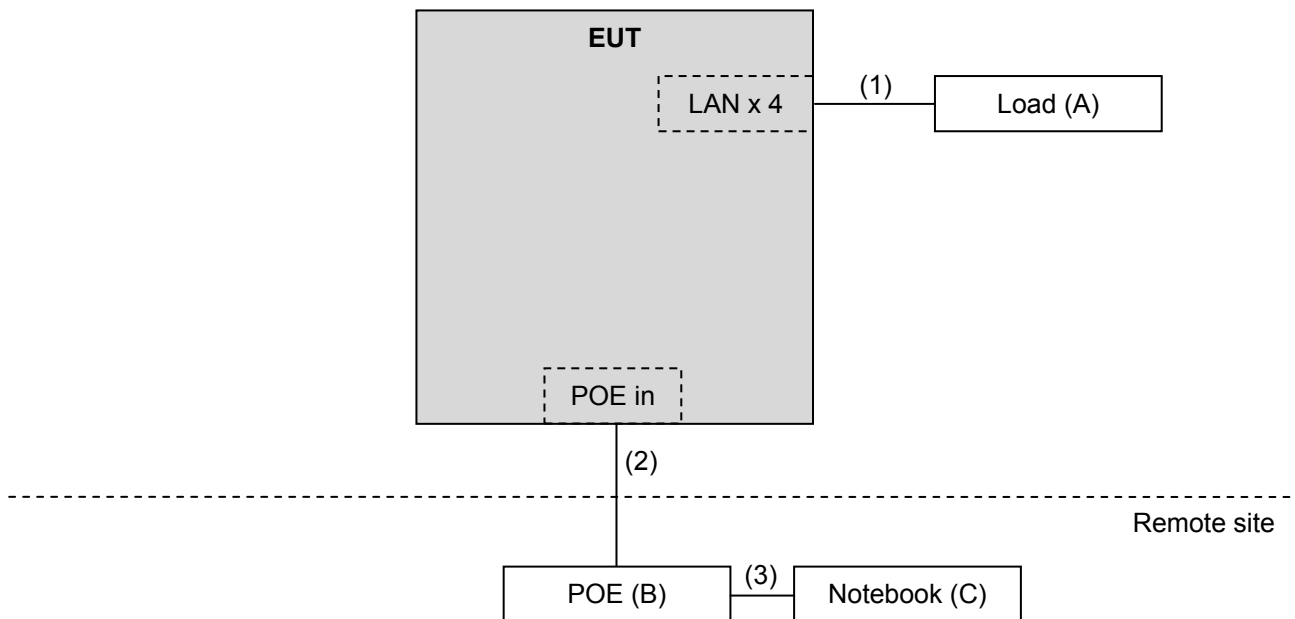

3.5 General Description of Applied Standards

The EUT is a RF Product. According to the specifications of the manufacturer, it must comply with the requirements of the following standards:

FCC Part 15, Subpart C (15.247)

KDB 558074 D01 DTS Meas Guidance v03r05

KDB 662911 D01 Multiple Transmitter Output v02r01

ANSI C63.10-2013

All test items have been performed and recorded as per the above standards.

Note: The EUT is also considered as a kind of computer peripheral, because the connection to computer is necessary for typical use. It has been verified to comply with the requirements of FCC Part 15, Subpart B, Class B (DoC). The test report has been issued separately.

4 Test Types and Results

4.1 Radiated Emission and Bandedge Measurement

4.1.1 Limits of Radiated Emission and Bandedge Measurement

Radiated emissions which fall in the restricted bands must comply with the radiated emission limits specified as below table. Other emissions shall be at least 20dB / 30dB below the highest level of the desired power:

Frequencies (MHz)	Field Strength (microvolts/meter)	Measurement Distance (meters)
0.009 ~ 0.490	2400/F(kHz)	300
0.490 ~ 1.705	24000/F(kHz)	30
1.705 ~ 30.0	30	30
30 ~ 88	100	3
88 ~ 216	150	3
216 ~ 960	200	3
Above 960	500	3

Note:

1. The lower limit shall apply at the transition frequencies.
2. Emission level (dBuV/m) = 20 log Emission level (uV/m).
3. For frequencies above 1000MHz, the field strength limits are based on average detector, however, the peak field strength of any emission shall not exceed the maximum permitted average limits, specified above by more than 20dB / 30dB under any condition of modulation.

4.1.2 Test Instruments

Description & Manufacturer	Model No.	Serial No.	Cal. Date	Cal. Due
Test Receiver ROHDE & SCHWARZ	ESIB7	100187	Apr. 18, 2016	Apr. 17, 2017
Spectrum Analyzer ROHDE & SCHWARZ	FSP40	100041	Sep. 02, 2015	Sep. 01, 2016
BILOG Antenna SCHWARZBECK	VULB9168	9168-171	Jan. 07, 2016	Jan. 06, 2017
HORN Antenna SCHWARZBECK	9120D	209	Jan. 20, 2016	Jan. 19, 2017
HORN Antenna SCHWARZBECK	BBHA 9170	BBHA9170241	Jan. 18, 2016	Jan. 17, 2017
Preamplifier Agilent	8447D	2944A10738	Oct. 18, 2015	Oct. 17, 2016
Preamplifier Agilent	8449B	3008A01964	Aug. 22, 2015	Aug. 21, 2016
			Aug. 22, 2016	Aug. 21, 2017
RF signal cable HUBER+SUHNER	SUCOFLEX 104	Cable-CH3-03 (214378)	Aug. 22, 2015	Aug. 21, 2016
			Aug. 22, 2016	Aug. 21, 2017
RF signal cable HUBER+SUHNER	SUCOFLEX 106	Cable-CH3-03 (309224+12738)	Aug. 22, 2015	Aug. 21, 2016
			Aug. 22, 2016	Aug. 21, 2017
Software BV ADT	ADT_Radiated_ V7.6.15.9.4	NA	NA	NA
Antenna Tower inn-co GmbH	MA 4000	013303	NA	NA
Antenna Tower Controller BV ADT	AT100	AT93021702	NA	NA
Turn Table BV ADT	TT100	TT93021702	NA	NA
Turn Table Controller BV ADT	SC100	SC93021702	NA	NA
High Speed Peak Power Meter	ML2495A	0824011	Jul. 09, 2015	Jul. 08, 2016
			Jul. 09, 2016	Jul. 08, 2017
Power Sensor	MA2411B	0738171	Jul. 09, 2015	Jul. 08, 2016
			Jul. 09, 2016	Jul. 08, 2017

- Note: 1. The calibration interval of the above test instruments is 12 months and the calibrations are traceable to NML/ROC and NIST/USA.
2. The test was performed in HwaYa Chamber 3.
3. The horn antenna and preamplifier (model: 8449B) are used only for the measurement of emission frequency above 1GHz if tested.
4. The FCC Site Registration No. is 988962.
5. The IC Site Registration No. is IC 7450F-3.

4.1.3 Test Procedures

- a. The EUT was placed on the top of a rotating table 0.8 meters (for below 1GHz) / 1.5 meters (for above 1GHz) above the ground at 3 meter chamber room for test. The table was rotated 360 degrees to determine the position of the highest radiation.
- b. The EUT was set 3 meters away from the interference-receiving antenna, which was mounted on the top of a variable-height antenna tower.
- c. The height of antenna is varied from one meter to four meters above the ground to determine the maximum value of the field strength. Both horizontal and vertical polarizations of the antenna are set to make the measurement.
- d. For each suspected emission, the EUT was arranged to its worst case and then the antenna was tuned to heights from 1 meter to 4 meters and the rotatable table was turned from 0 degrees to 360 degrees to find the maximum reading.
- e. The test-receiver system was set to quasi-peak detect function and specified bandwidth with maximum hold mode when the test frequency is below 1 GHz.
- f. The test-receiver system was set to peak and average detect function and specified bandwidth with maximum hold mode when the test frequency is above 1 GHz. If the peak reading value also meets average limit, measurement with the average detector is unnecessary.

Note:

1. The resolution bandwidth and video bandwidth of test receiver/spectrum analyzer is 120kHz for Quasi-peak detection (QP) at frequency below 1GHz.
2. The resolution bandwidth of test receiver/spectrum analyzer is 1 MHz and the video bandwidth is 3 MHz for Peak detection (PK) at frequency above 1GHz.
3. The resolution bandwidth of test receiver/spectrum analyzer is 1MHz and the video bandwidth is 3MHz for RMS Average (Duty cycle < 98%) for Average detection (AV) at frequency above 1GHz, then the measurement results was added to a correction factor ($10 \log(1/\text{duty cycle})$).
4. The resolution bandwidth of test receiver/spectrum analyzer is 1MHz and the video bandwidth is 10Hz (Duty cycle $\geq 98\%$) for Average detection (AV) at frequency above 1GHz.
5. All modes of operation were investigated and the worst-case emissions are reported.

4.1.4 Deviation from Test Standard

No deviation.

4.1.5 Test Set Up

<Frequency Range below 1GHz>

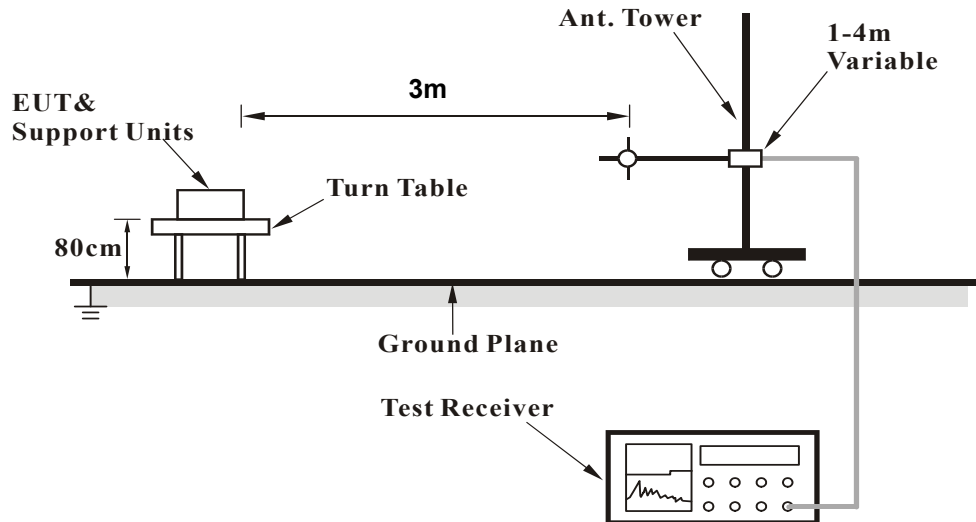

<Frequency Range above 1GHz>

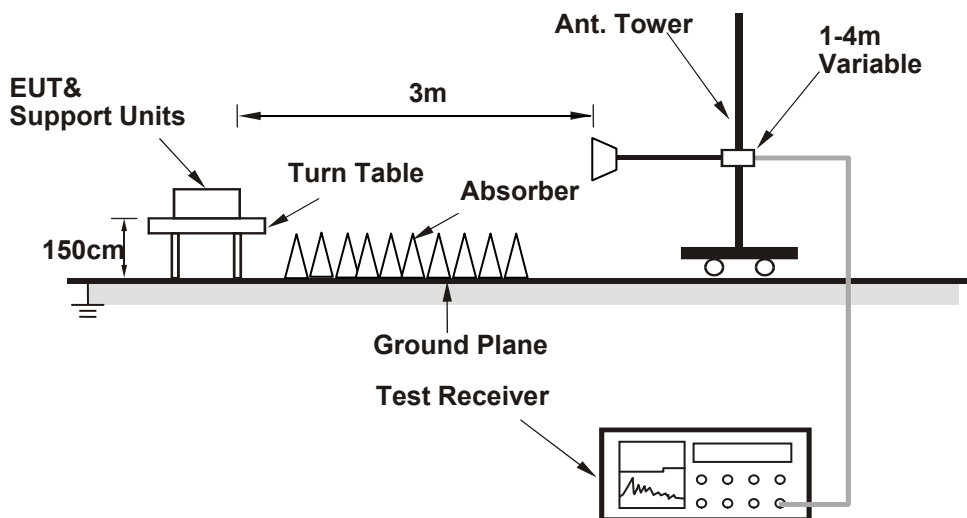

For the actual test configuration, please refer to the attached file (Test Setup Photo).

4.1.6 EUT Operating Conditions

- Placed the EUT on the testing table.
- Prepared a notebook to act as a communication partner and placed it outside of testing area.
- The communication partner connected with EUT via a RJ45 cable and ran a test program (provided by manufacturer) to enable EUT under transmission condition continuously at specific channel frequency.
- The communication partner sent data to EUT by command "PING".

4.1.7 Test Results

Above 1GHz worst-Case data:

Radio 1: CDD Mode

802.11b

CHANNEL	TX Channel 1	DETECTOR FUNCTION	Peak (PK)
FREQUENCY RANGE	1GHz ~ 25GHz		Average (AV)

ANTENNA POLARITY & TEST DISTANCE: HORIZONTAL AT 3 M								
NO.	FREQ. (MHz)	EMISSION LEVEL (dBuV/m)	LIMIT (dBuV/m)	MARGIN (dB)	ANTENNA HEIGHT (m)	TABLE ANGLE (Degree)	RAW VALUE (dBuV)	CORRECTION FACTOR (dB/m)
1	2390.00	58.8 PK	74.0	-15.2	2.38 H	295	26.0	32.8
2	2390.00	51.1 AV	54.0	-2.9	2.38 H	295	18.3	32.8
3	*2412.00	112.8 PK			2.48 H	26	79.9	32.9
4	*2412.00	110.7 AV			2.48 H	26	77.8	32.9
5	4824.00	47.0 PK	74.0	-27.0	1.60 H	304	41.1	5.9
6	4824.00	36.5 AV	54.0	-17.5	1.60 H	304	30.6	5.9
ANTENNA POLARITY & TEST DISTANCE: VERTICAL AT 3 M								
NO.	FREQ. (MHz)	EMISSION LEVEL (dBuV/m)	LIMIT (dBuV/m)	MARGIN (dB)	ANTENNA HEIGHT (m)	TABLE ANGLE (Degree)	RAW VALUE (dBuV)	CORRECTION FACTOR (dB/m)
1	2390.00	58.8 PK	74.0	-15.2	2.34 V	54	26.0	32.8
2	2390.00	51.1 AV	54.0	-2.9	2.34 V	54	18.3	32.8
3	*2412.00	111.1 PK			1.69 V	18	78.2	32.9
4	*2412.00	107.1 AV			1.69 V	18	74.2	32.9
5	4824.00	46.5 PK	74.0	-27.5	2.16 V	189	40.6	5.9
6	4824.00	33.2 AV	54.0	-20.8	2.16 V	189	27.3	5.9

Remarks:

1. Emission Level(dBuV/m) = Raw Value(dBuV) + Correction Factor(dB/m)
2. Correction Factor(dB/m) = Antenna Factor(dB/m) + Cable Factor(dB)
3. The other emission levels were very low against the limit.
4. Margin value = Emission Level – Limit value
5. " * ": Fundamental frequency.

CHANNEL	TX Channel 6	DETECTOR FUNCTION	Peak (PK)
FREQUENCY RANGE	1GHz ~ 25GHz		Average (AV)

ANTENNA POLARITY & TEST DISTANCE: HORIZONTAL AT 3 M

NO.	FREQ. (MHz)	EMISSION LEVEL (dBuV/m)	LIMIT (dBuV/m)	MARGIN (dB)	ANTENNA HEIGHT (m)	TABLE ANGLE (Degree)	RAW VALUE (dBuV)	CORRECTION FACTOR (dB/m)
1	*2437.00	113.2 PK			1.06 H	271	80.3	32.9
2	*2437.00	75.2 AV			1.06 H	271	76.4	-1.2
3	4874.00	46.6 PK	74.0	-27.4	1.84 H	295	40.6	6.0
4	4874.00	35.3 AV	54.0	-18.7	1.84 H	295	29.3	6.0

ANTENNA POLARITY & TEST DISTANCE: VERTICAL AT 3 M

NO.	FREQ. (MHz)	EMISSION LEVEL (dBuV/m)	LIMIT (dBuV/m)	MARGIN (dB)	ANTENNA HEIGHT (m)	TABLE ANGLE (Degree)	RAW VALUE (dBuV)	CORRECTION FACTOR (dB/m)
1	*2437.00	110.4 PK			1.66 V	20	77.5	32.9
2	*2437.00	108.3 AV			1.66 V	20	75.4	32.9
3	4874.00	46.7 PK	74.0	-27.3	2.64 V	115	40.7	6.0
4	4874.00	33.6 AV	54.0	-20.4	2.64 V	115	27.6	6.0

Remarks:

1. Emission Level(dBuV/m) = Raw Value(dBuV) + Correction Factor(dB/m)
2. Correction Factor(dB/m) = Antenna Factor(dB/m) + Cable Factor(dB)
3. The other emission levels were very low against the limit.
4. Margin value = Emission Level – Limit value
5. " * ": Fundamental frequency.

CHANNEL	TX Channel 11	DETECTOR FUNCTION	Peak (PK)
FREQUENCY RANGE	1GHz ~ 25GHz		Average (AV)

ANTENNA POLARITY & TEST DISTANCE: HORIZONTAL AT 3 M								
NO.	FREQ. (MHz)	EMISSION LEVEL (dBuV/m)	LIMIT (dBuV/m)	MARGIN (dB)	ANTENNA HEIGHT (m)	TABLE ANGLE (Degree)	RAW VALUE (dBuV)	CORRECTION FACTOR (dB/m)
1	*2462.00	112.1 PK			3.40 H	217	79.2	32.9
2	*2462.00	109.7 AV			3.40 H	217	76.8	32.9
3	2483.50	58.8 PK	74.0	-15.2	1.33 H	276	25.8	33.0
4	2483.50	50.4 AV	54.0	-3.6	1.33 H	276	17.4	33.0
5	4924.00	47.2 PK	74.0	-26.8	1.74 H	25	41.2	6.0
6	4924.00	36.7 AV	54.0	-17.3	1.74 H	25	30.7	6.0
ANTENNA POLARITY & TEST DISTANCE: VERTICAL AT 3 M								
NO.	FREQ. (MHz)	EMISSION LEVEL (dBuV/m)	LIMIT (dBuV/m)	MARGIN (dB)	ANTENNA HEIGHT (m)	TABLE ANGLE (Degree)	RAW VALUE (dBuV)	CORRECTION FACTOR (dB/m)
1	*2462.00	107.5 PK			3.39 V	217	74.6	32.9
2	*2462.00	104.4 AV			3.39 V	217	71.5	32.9
3	2483.50	59.5 PK	74.0	-14.5	1.88 V	14	26.5	33.0
4	2483.50	52.0 AV	54.0	-2.0	1.88 V	14	19.0	33.0
5	4924.00	48.5 PK	74.0	-25.5	1.74 V	25	42.5	6.0
6	4924.00	37.2 AV	54.0	-16.8	1.74 V	25	31.2	6.0

Remarks:

1. Emission Level(dBuV/m) = Raw Value(dBuV) + Correction Factor(dB/m)
2. Correction Factor(dB/m) = Antenna Factor(dB/m) + Cable Factor(dB)
3. The other emission levels were very low against the limit.
4. Margin value = Emission Level – Limit value
5. " * ": Fundamental frequency.

802.11g

CHANNEL	TX Channel 1	DETECTOR FUNCTION	Peak (PK)
FREQUENCY RANGE	1GHz ~ 25GHz		Average (AV)

ANTENNA POLARITY & TEST DISTANCE: HORIZONTAL AT 3 M

NO.	FREQ. (MHz)	EMISSION LEVEL (dBuV/m)	LIMIT (dBuV/m)	MARGIN (dB)	ANTENNA HEIGHT (m)	TABLE ANGLE (Degree)	RAW VALUE (dBuV)	CORRECTION FACTOR (dB/m)
1	2390.00	65.7 PK	74.0	-8.3	1.00 H	213	32.9	32.8
2	2390.00	52.7 AV	54.0	-1.3	1.00 H	213	19.9	32.8
3	*2412.00	109.7 PK			1.43 H	284	76.8	32.9
4	*2412.00	99.6 AV			1.43 H	284	66.7	32.9
5	4824.00	47.1 PK	74.0	-26.9	1.42 H	66	41.2	5.9
6	4824.00	35.3 AV	54.0	-18.7	1.42 H	66	29.4	5.9

ANTENNA POLARITY & TEST DISTANCE: VERTICAL AT 3 M

NO.	FREQ. (MHz)	EMISSION LEVEL (dBuV/m)	LIMIT (dBuV/m)	MARGIN (dB)	ANTENNA HEIGHT (m)	TABLE ANGLE (Degree)	RAW VALUE (dBuV)	CORRECTION FACTOR (dB/m)
1	2390.00	68.3 PK	74.0	-5.7	2.34 V	49	35.5	32.8
2	2390.00	52.6 AV	54.0	-1.4	2.34 V	49	19.8	32.8
3	*2412.00	108.6 PK			1.76 V	11	75.7	32.9
4	*2412.00	97.9 AV			1.76 V	11	65.0	32.9
5	4824.00	49.4 PK	74.0	-24.6	2.11 V	179	43.5	5.9
6	4824.00	39.6 AV	54.0	-14.4	2.11 V	179	33.7	5.9

Remarks:

1. Emission Level(dBuV/m) = Raw Value(dBuV) + Correction Factor(dB/m)
2. Correction Factor(dB/m) = Antenna Factor(dB/m) + Cable Factor(dB)
3. The other emission levels were very low against the limit.
4. Margin value = Emission Level – Limit value
5. " * ": Fundamental frequency.

CHANNEL	TX Channel 6	DETECTOR	Peak (PK)
FREQUENCY RANGE	1GHz ~ 25GHz	FUNCTION	Average (AV)

ANTENNA POLARITY & TEST DISTANCE: HORIZONTAL AT 3 M

NO.	FREQ. (MHz)	EMISSION LEVEL (dBuV/m)	LIMIT (dBuV/m)	MARGIN (dB)	ANTENNA HEIGHT (m)	TABLE ANGLE (Degree)	RAW VALUE (dBuV)	CORRECTION FACTOR (dB/m)
1	*2437.00	112.6 PK			1.59 H	284	79.7	32.9
2	*2437.00	102.4 AV			1.59 H	284	69.5	32.9
3	4874.00	46.6 PK	74.0	-27.4	1.76 H	201	40.6	6.0
4	4874.00	33.8 AV	54.0	-20.2	1.76 H	201	27.8	6.0

ANTENNA POLARITY & TEST DISTANCE: VERTICAL AT 3 M

NO.	FREQ. (MHz)	EMISSION LEVEL (dBuV/m)	LIMIT (dBuV/m)	MARGIN (dB)	ANTENNA HEIGHT (m)	TABLE ANGLE (Degree)	RAW VALUE (dBuV)	CORRECTION FACTOR (dB/m)
1	*2437.00	112.3 PK			1.66 V	356	79.4	32.9
2	*2437.00	101.9 AV			1.66 V	356	69.0	32.9
3	4874.00	46.4 PK	74.0	-27.6	1.85 V	296	40.4	6.0
4	4874.00	34.4 AV	54.0	-19.6	1.85 V	296	28.4	6.0

Remarks:

1. Emission Level(dBuV/m) = Raw Value(dBuV) + Correction Factor(dB/m)
2. Correction Factor(dB/m) = Antenna Factor(dB/m) + Cable Factor(dB)
3. The other emission levels were very low against the limit.
4. Margin value = Emission Level – Limit value
5. " * ": Fundamental frequency.

CHANNEL	TX Channel 11	DETECTOR	Peak (PK)
FREQUENCY RANGE	1GHz ~ 25GHz	FUNCTION	Average (AV)

ANTENNA POLARITY & TEST DISTANCE: HORIZONTAL AT 3 M								
NO.	FREQ. (MHz)	EMISSION LEVEL (dBuV/m)	LIMIT (dBuV/m)	MARGIN (dB)	ANTENNA HEIGHT (m)	TABLE ANGLE (Degree)	RAW VALUE (dBuV)	CORRECTION FACTOR (dB/m)
1	*2462.00	109.6 PK			1.52 H	268	76.7	32.9
2	*2462.00	99.1 AV			1.52 H	268	66.2	32.9
3	2483.50	68.5 PK	74.0	-5.5	1.43 H	6	35.5	33.0
4	2483.50	52.5 AV	54.0	-1.5	1.43 H	6	19.5	33.0
5	4924.00	48.1 PK	74.0	-25.9	1.56 H	35	42.1	6.0
6	4924.00	35.8 AV	54.0	-18.2	1.56 H	35	29.8	6.0

ANTENNA POLARITY & TEST DISTANCE: VERTICAL AT 3 M								
NO.	FREQ. (MHz)	EMISSION LEVEL (dBuV/m)	LIMIT (dBuV/m)	MARGIN (dB)	ANTENNA HEIGHT (m)	TABLE ANGLE (Degree)	RAW VALUE (dBuV)	CORRECTION FACTOR (dB/m)
1	*2462.00	109.2 PK			2.12 V	10	76.3	32.9
2	*2462.00	98.5 AV			2.12 V	10	65.6	32.9
3	2483.50	68.3 PK	74.0	-5.7	2.33 V	243	35.3	33.0
4	2483.50	52.3 AV	54.0	-1.7	2.33 V	243	19.3	33.0
5	4924.00	49.3 PK	74.0	-24.7	1.79 V	111	43.3	6.0
6	4924.00	38.7 AV	54.0	-15.3	1.79 V	111	32.7	6.0

Remarks:

1. Emission Level(dBuV/m) = Raw Value(dBuV) + Correction Factor(dB/m)
2. Correction Factor(dB/m) = Antenna Factor(dB/m) + Cable Factor(dB)
3. The other emission levels were very low against the limit.
4. Margin value = Emission Level – Limit value
5. " * ": Fundamental frequency.

802.11n (HT20)

CHANNEL	TX Channel 1	DETECTOR FUNCTION	Peak (PK)
FREQUENCY RANGE	1GHz ~ 25GHz		Average (AV)

ANTENNA POLARITY & TEST DISTANCE: HORIZONTAL AT 3 M

NO.	FREQ. (MHz)	EMISSION LEVEL (dBuV/m)	LIMIT (dBuV/m)	MARGIN (dB)	ANTENNA HEIGHT (m)	TABLE ANGLE (Degree)	RAW VALUE (dBuV)	CORRECTION FACTOR (dB/m)
1	2390.00	67.5 PK	74.0	-6.5	2.87 H	20	34.7	32.8
2	2390.00	52.4 AV	54.0	-1.6	2.87 H	20	19.6	32.8
3	*2412.00	109.4 PK			2.09 H	289	76.5	32.9
4	*2412.00	98.3 AV			2.09 H	289	65.4	32.9
5	4824.00	47.0 PK	74.0	-27.0	1.39 H	70	41.1	5.9
6	4824.00	35.4 AV	54.0	-18.6	1.39 H	70	29.5	5.9

ANTENNA POLARITY & TEST DISTANCE: VERTICAL AT 3 M

NO.	FREQ. (MHz)	EMISSION LEVEL (dBuV/m)	LIMIT (dBuV/m)	MARGIN (dB)	ANTENNA HEIGHT (m)	TABLE ANGLE (Degree)	RAW VALUE (dBuV)	CORRECTION FACTOR (dB/m)
1	2390.00	66.6 PK	74.0	-7.4	2.02 V	18	33.8	32.8
2	2390.00	50.7 AV	54.0	-3.3	2.02 V	18	17.9	32.8
3	*2412.00	105.9 PK			2.02 V	18	73.0	32.9
4	*2412.00	95.9 AV			2.02 V	18	63.0	32.9
5	4824.00	47.2 PK	74.0	-26.8	1.79 V	212	41.3	5.9
6	4824.00	37.2 AV	54.0	-16.8	1.79 V	212	31.3	5.9

Remarks:

1. Emission Level(dBuV/m) = Raw Value(dBuV) + Correction Factor(dB/m)
2. Correction Factor(dB/m) = Antenna Factor(dB/m) + Cable Factor(dB)
3. The other emission levels were very low against the limit.
4. Margin value = Emission Level – Limit value
5. " * ": Fundamental frequency.

CHANNEL	TX Channel 6	DETECTOR FUNCTION	Peak (PK)
FREQUENCY RANGE	1GHz ~ 25GHz		Average (AV)

ANTENNA POLARITY & TEST DISTANCE: HORIZONTAL AT 3 M

NO.	FREQ. (MHz)	EMISSION LEVEL (dBuV/m)	LIMIT (dBuV/m)	MARGIN (dB)	ANTENNA HEIGHT (m)	TABLE ANGLE (Degree)	RAW VALUE (dBuV)	CORRECTION FACTOR (dB/m)
1	*2437.00	113.2 PK			1.32 H	270	80.3	32.9
2	*2437.00	101.6 AV			1.32 H	270	68.7	32.9
3	4874.00	46.1 PK	74.0	-27.9	1.63 H	201	40.1	6.0
4	4874.00	34.1 AV	54.0	-19.9	1.63 H	201	28.1	6.0

ANTENNA POLARITY & TEST DISTANCE: VERTICAL AT 3 M

NO.	FREQ. (MHz)	EMISSION LEVEL (dBuV/m)	LIMIT (dBuV/m)	MARGIN (dB)	ANTENNA HEIGHT (m)	TABLE ANGLE (Degree)	RAW VALUE (dBuV)	CORRECTION FACTOR (dB/m)
1	*2437.00	112.5 PK			1.93 V	12	79.6	32.9
2	*2437.00	101.6 AV			1.93 V	12	68.7	32.9
3	4874.00	48.8 PK	74.0	-25.2	2.09 V	222	42.8	6.0
4	4874.00	38.7 AV	54.0	-15.3	2.09 V	222	32.7	6.0

Remarks:

1. Emission Level(dBuV/m) = Raw Value(dBuV) + Correction Factor(dB/m)
2. Correction Factor(dB/m) = Antenna Factor(dB/m) + Cable Factor(dB)
3. The other emission levels were very low against the limit.
4. Margin value = Emission Level – Limit value
5. " * ": Fundamental frequency.

CHANNEL	TX Channel 11	DETECTOR FUNCTION	Peak (PK)
FREQUENCY RANGE	1GHz ~ 25GHz		Average (AV)

ANTENNA POLARITY & TEST DISTANCE: HORIZONTAL AT 3 M								
NO.	FREQ. (MHz)	EMISSION LEVEL (dBuV/m)	LIMIT (dBuV/m)	MARGIN (dB)	ANTENNA HEIGHT (m)	TABLE ANGLE (Degree)	RAW VALUE (dBuV)	CORRECTION FACTOR (dB/m)
1	*2462.00	108.8 PK			2.04 H	282	75.9	32.9
2	*2462.00	98.5 AV			2.04 H	282	65.6	32.9
3	2483.50	69.3 PK	74.0	-4.7	2.86 H	17	36.3	33.0
4	2483.50	52.4 AV	54.0	-1.6	2.86 H	17	19.4	33.0
5	4924.00	47.5 PK	74.0	-26.5	1.76 H	44	41.5	6.0
6	4924.00	35.6 AV	54.0	-18.4	1.76 H	44	29.6	6.0

ANTENNA POLARITY & TEST DISTANCE: VERTICAL AT 3 M								
NO.	FREQ. (MHz)	EMISSION LEVEL (dBuV/m)	LIMIT (dBuV/m)	MARGIN (dB)	ANTENNA HEIGHT (m)	TABLE ANGLE (Degree)	RAW VALUE (dBuV)	CORRECTION FACTOR (dB/m)
1	*2462.00	107.8 PK			2.11 V	6	74.9	32.9
2	*2462.00	97.9 AV			2.11 V	6	65.0	32.9
3	2483.50	65.3 PK	74.0	-8.7	1.92 V	14	32.3	33.0
4	2483.50	50.3 AV	54.0	-3.7	1.92 V	14	17.3	33.0
5	4924.00	48.1 PK	74.0	-25.9	1.59 V	234	42.1	6.0
6	4924.00	37.5 AV	54.0	-16.5	1.59 V	234	31.5	6.0

Remarks:

1. Emission Level(dBuV/m) = Raw Value(dBuV) + Correction Factor(dB/m)
2. Correction Factor(dB/m) = Antenna Factor(dB/m) + Cable Factor(dB)
3. The other emission levels were very low against the limit.
4. Margin value = Emission Level – Limit value
5. " * ": Fundamental frequency.

802.11n (HT40)

CHANNEL	TX Channel 3	DETECTOR FUNCTION	Peak (PK)
FREQUENCY RANGE	1GHz ~ 25GHz		Average (AV)

ANTENNA POLARITY & TEST DISTANCE: HORIZONTAL AT 3 M								
NO.	FREQ. (MHz)	EMISSION LEVEL (dBuV/m)	LIMIT (dBuV/m)	MARGIN (dB)	ANTENNA HEIGHT (m)	TABLE ANGLE (Degree)	RAW VALUE (dBuV)	CORRECTION FACTOR (dB/m)
1	2390.00	68.1 PK	74.0	-5.9	1.66 H	10	35.3	32.8
2	2390.00	52.4 AV	54.0	-1.6	1.66 H	10	19.6	32.8
3	*2422.00	104.8 PK			2.05 H	284	71.9	32.9
4	*2422.00	95.2 AV			2.05 H	284	62.3	32.9
5	4844.00	48.0 PK	74.0	-26.0	1.26 H	133	42.2	5.8
6	4844.00	34.6 AV	54.0	-19.4	1.26 H	133	28.8	5.8
ANTENNA POLARITY & TEST DISTANCE: VERTICAL AT 3 M								
NO.	FREQ. (MHz)	EMISSION LEVEL (dBuV/m)	LIMIT (dBuV/m)	MARGIN (dB)	ANTENNA HEIGHT (m)	TABLE ANGLE (Degree)	RAW VALUE (dBuV)	CORRECTION FACTOR (dB/m)
1	2390.00	69.9 PK	74.0	-4.1	1.78 V	356	37.1	32.8
2	2390.00	52.9 AV	54.0	-1.1	1.78 V	356	20.1	32.8
3	*2422.00	103.4 PK			1.97 V	0	70.5	32.9
4	*2422.00	94.8 AV			1.97 V	0	61.9	32.9
5	4844.00	48.2 PK	74.0	-25.8	2.01 V	344	42.4	5.8
6	4844.00	38.0 AV	54.0	-16.0	2.01 V	344	32.2	5.8

Remarks:

1. Emission Level(dBuV/m) = Raw Value(dBuV) + Correction Factor(dB/m)
2. Correction Factor(dB/m) = Antenna Factor(dB/m) + Cable Factor(dB)
3. The other emission levels were very low against the limit.
4. Margin value = Emission Level – Limit value
5. " * " : Fundamental frequency.

CHANNEL	TX Channel 6	DETECTOR FUNCTION	Peak (PK)
FREQUENCY RANGE	1GHz ~ 25GHz		Average (AV)

ANTENNA POLARITY & TEST DISTANCE: HORIZONTAL AT 3 M

NO.	FREQ. (MHz)	EMISSION LEVEL (dBuV/m)	LIMIT (dBuV/m)	MARGIN (dB)	ANTENNA HEIGHT (m)	TABLE ANGLE (Degree)	RAW VALUE (dBuV)	CORRECTION FACTOR (dB/m)
1	2390.00	67.4 PK	74.0	-6.6	3.35 H	55	34.6	32.8
2	2390.00	52.5 AV	54.0	-1.5	3.35 H	55	19.7	32.8
3	*2437.00	105.8 PK			1.57 H	261	72.9	32.9
4	*2437.00	97.2 AV			1.57 H	261	64.3	32.9
5	2483.50	65.1 PK	74.0	-8.9	2.33 H	357	32.1	33.0
6	2483.50	51.3 AV	54.0	-2.7	2.33 H	357	18.3	33.0
7	4874.00	46.9 PK	74.0	-27.1	1.87 H	301	40.9	6.0
8	4874.00	34.3 AV	54.0	-19.7	1.87 H	301	28.3	6.0

ANTENNA POLARITY & TEST DISTANCE: VERTICAL AT 3 M

NO.	FREQ. (MHz)	EMISSION LEVEL (dBuV/m)	LIMIT (dBuV/m)	MARGIN (dB)	ANTENNA HEIGHT (m)	TABLE ANGLE (Degree)	RAW VALUE (dBuV)	CORRECTION FACTOR (dB/m)
1	2390.00	60.7 PK	74.0	-13.3	1.00 V	46	27.9	32.8
2	2390.00	49.7 AV	54.0	-4.3	1.00 V	46	16.9	32.8
3	*2437.00	106.5 PK			1.92 V	9	73.6	32.9
4	*2437.00	97.0 AV			1.92 V	9	64.1	32.9
5	2483.50	65.2 PK	74.0	-8.8	1.87 V	345	32.2	33.0
6	2483.50	50.9 AV	54.0	-3.1	1.87 V	345	17.9	33.0
7	4874.00	49.0 PK	74.0	-25.0	1.77 V	55	43.0	6.0
8	4874.00	38.6 AV	54.0	-15.4	1.77 V	55	32.6	6.0

Remarks:

1. Emission Level(dBuV/m) = Raw Value(dBuV) + Correction Factor(dB/m)
2. Correction Factor(dB/m) = Antenna Factor(dB/m) + Cable Factor(dB)
3. The other emission levels were very low against the limit.
4. Margin value = Emission Level – Limit value
5. " * ": Fundamental frequency.

CHANNEL	TX Channel 9	DETECTOR FUNCTION	Peak (PK)
FREQUENCY RANGE	1GHz ~ 25GHz		Average (AV)

ANTENNA POLARITY & TEST DISTANCE: HORIZONTAL AT 3 M

NO.	FREQ. (MHz)	EMISSION LEVEL (dBuV/m)	LIMIT (dBuV/m)	MARGIN (dB)	ANTENNA HEIGHT (m)	TABLE ANGLE (Degree)	RAW VALUE (dBuV)	CORRECTION FACTOR (dB/m)
1	*2452.00	105.1 PK			1.65 H	290	72.1	33.0
2	*2452.00	95.7 AV			1.65 H	290	62.7	33.0
3	2483.50	70.3 PK	74.0	-3.7	2.22 H	282	37.3	33.0
4	2483.50	52.5 AV	54.0	-1.5	2.22 H	282	19.5	33.0
5	4904.00	48.0 PK	74.0	-26.0	1.74 H	158	42.1	5.9
6	4904.00	34.6 AV	54.0	-19.4	1.74 H	158	28.7	5.9

ANTENNA POLARITY & TEST DISTANCE: VERTICAL AT 3 M

NO.	FREQ. (MHz)	EMISSION LEVEL (dBuV/m)	LIMIT (dBuV/m)	MARGIN (dB)	ANTENNA HEIGHT (m)	TABLE ANGLE (Degree)	RAW VALUE (dBuV)	CORRECTION FACTOR (dB/m)
1	*2452.00	104.4 PK			1.79 V	7	71.4	33.0
2	*2452.00	95.1 AV			1.79 V	7	62.1	33.0
3	2483.50	66.1 PK	74.0	-7.9	1.46 V	342	33.1	33.0
4	2483.50	51.8 AV	54.0	-2.2	1.46 V	342	18.8	33.0
5	4904.00	48.4 PK	74.0	-25.6	2.12 V	190	42.5	5.9
6	4904.00	37.5 AV	54.0	-16.5	2.12 V	190	31.6	5.9

Remarks:

1. Emission Level(dBuV/m) = Raw Value(dBuV) + Correction Factor(dB/m)
2. Correction Factor(dB/m) = Antenna Factor(dB/m) + Cable Factor(dB)
3. The other emission levels were very low against the limit.
4. Margin value = Emission Level – Limit value
5. " * ": Fundamental frequency.

Radio 1: Beamforming Mode

802.11n (HT20)

CHANNEL	TX Channel 1	DETECTOR FUNCTION	Peak (PK)
FREQUENCY RANGE	1GHz ~ 25GHz		Average (AV)

ANTENNA POLARITY & TEST DISTANCE: HORIZONTAL AT 3 M

NO.	FREQ. (MHz)	EMISSION LEVEL (dBuV/m)	LIMIT (dBuV/m)	MARGIN (dB)	ANTENNA HEIGHT (m)	TABLE ANGLE (Degree)	RAW VALUE (dBuV)	CORRECTION FACTOR (dB/m)
1	2390.00	66.3 PK	74.0	-7.7	1.65 H	280	33.5	32.8
2	2390.00	52.6 AV	54.0	-1.4	1.65 H	280	19.8	32.8
3	*2412.00	110.3 PK			1.92 H	282	77.4	32.9
4	*2412.00	103.1 AV			1.92 H	282	70.2	32.9
5	4824.00	46.4 PK	74.0	-27.6	1.89 H	265	40.5	5.9
6	4824.00	34.1 AV	54.0	-19.9	1.89 H	265	28.2	5.9

ANTENNA POLARITY & TEST DISTANCE: VERTICAL AT 3 M

NO.	FREQ. (MHz)	EMISSION LEVEL (dBuV/m)	LIMIT (dBuV/m)	MARGIN (dB)	ANTENNA HEIGHT (m)	TABLE ANGLE (Degree)	RAW VALUE (dBuV)	CORRECTION FACTOR (dB/m)
1	2390.00	67.3 PK	74.0	-6.7	1.00 V	358	34.5	32.8
2	2390.00	52.6 AV	54.0	-1.4	1.00 V	358	19.8	32.8
3	*2412.00	107.9 PK			1.72 V	9	75.0	32.9
4	*2412.00	101.3 AV			1.72 V	9	68.4	32.9
5	4824.00	46.5 PK	74.0	-27.5	1.36 V	215	40.6	5.9
6	4824.00	34.2 AV	54.0	-19.8	1.36 V	215	28.3	5.9

Remarks:

1. Emission Level(dBuV/m) = Raw Value(dBuV) + Correction Factor(dB/m)
2. Correction Factor(dB/m) = Antenna Factor(dB/m) + Cable Factor(dB)
3. The other emission levels were very low against the limit.
4. Margin value = Emission Level – Limit value
5. " * ": Fundamental frequency.

CHANNEL	TX Channel 6	DETECTOR FUNCTION	Peak (PK)
FREQUENCY RANGE	1GHz ~ 25GHz		Average (AV)

ANTENNA POLARITY & TEST DISTANCE: HORIZONTAL AT 3 M

NO.	FREQ. (MHz)	EMISSION LEVEL (dBuV/m)	LIMIT (dBuV/m)	MARGIN (dB)	ANTENNA HEIGHT (m)	TABLE ANGLE (Degree)	RAW VALUE (dBuV)	CORRECTION FACTOR (dB/m)
1	*2437.00	112.8 PK			1.93 H	293	79.9	32.9
2	*2437.00	107.9 AV			1.93 H	293	75.0	32.9
3	4874.00	47.2 PK	74.0	-26.8	2.46 H	305	41.2	6.0
4	4874.00	34.1 AV	54.0	-19.9	2.46 H	305	28.1	6.0

ANTENNA POLARITY & TEST DISTANCE: VERTICAL AT 3 M

NO.	FREQ. (MHz)	EMISSION LEVEL (dBuV/m)	LIMIT (dBuV/m)	MARGIN (dB)	ANTENNA HEIGHT (m)	TABLE ANGLE (Degree)	RAW VALUE (dBuV)	CORRECTION FACTOR (dB/m)
1	*2437.00	110.9 PK			1.46 V	239	78.0	32.9
2	*2437.00	104.8 AV			1.46 V	239	71.9	32.9
3	4874.00	46.5 PK	74.0	-27.5	2.05 V	146	40.5	6.0
4	4874.00	34.1 AV	54.0	-19.9	2.05 V	146	28.1	6.0

Remarks:

1. Emission Level(dBuV/m) = Raw Value(dBuV) + Correction Factor(dB/m)
2. Correction Factor(dB/m) = Antenna Factor(dB/m) + Cable Factor(dB)
3. The other emission levels were very low against the limit.
4. Margin value = Emission Level – Limit value
5. " * ": Fundamental frequency.

CHANNEL	TX Channel 11	DETECTOR	Peak (PK)
FREQUENCY RANGE	1GHz ~ 25GHz	FUNCTION	Average (AV)

ANTENNA POLARITY & TEST DISTANCE: HORIZONTAL AT 3 M								
NO.	FREQ. (MHz)	EMISSION LEVEL (dBuV/m)	LIMIT (dBuV/m)	MARGIN (dB)	ANTENNA HEIGHT (m)	TABLE ANGLE (Degree)	RAW VALUE (dBuV)	CORRECTION FACTOR (dB/m)
1	*2462.00	110.3 PK			1.81 H	282	77.4	32.9
2	*2462.00	99.6 AV			1.81 H	282	66.7	32.9
3	2483.50	66.5 PK	74.0	-7.5	2.12 H	22	33.5	33.0
4	2483.50	51.4 AV	54.0	-2.6	2.12 H	22	18.4	33.0
5	4924.00	47.5 PK	74.0	-26.5	2.03 H	219	41.5	6.0
6	4924.00	34.1 AV	54.0	-19.9	2.03 H	219	28.1	6.0
ANTENNA POLARITY & TEST DISTANCE: VERTICAL AT 3 M								
NO.	FREQ. (MHz)	EMISSION LEVEL (dBuV/m)	LIMIT (dBuV/m)	MARGIN (dB)	ANTENNA HEIGHT (m)	TABLE ANGLE (Degree)	RAW VALUE (dBuV)	CORRECTION FACTOR (dB/m)
1	*2462.00	108.9 PK			1.46 V	359	76.0	32.9
2	*2462.00	100.2 AV			1.46 V	359	67.3	32.9
3	2483.50	68.0 PK	74.0	-6.0	1.41 V	4	35.0	33.0
4	2483.50	51.1 AV	54.0	-2.9	1.41 V	4	18.1	33.0
5	4924.00	47.5 PK	74.0	-26.5	1.58 V	85	41.5	6.0
6	4924.00	34.1 AV	54.0	-19.9	1.58 V	85	28.1	6.0

Remarks:

1. Emission Level(dBuV/m) = Raw Value(dBuV) + Correction Factor(dB/m)
2. Correction Factor(dB/m) = Antenna Factor(dB/m) + Cable Factor(dB)
3. The other emission levels were very low against the limit.
4. Margin value = Emission Level – Limit value
5. " * ": Fundamental frequency.

802.11n (HT40)

CHANNEL	TX Channel 3	DETECTOR FUNCTION	Peak (PK)
FREQUENCY RANGE	1GHz ~ 25GHz		Average (AV)

ANTENNA POLARITY & TEST DISTANCE: HORIZONTAL AT 3 M

NO.	FREQ. (MHz)	EMISSION LEVEL (dBuV/m)	LIMIT (dBuV/m)	MARGIN (dB)	ANTENNA HEIGHT (m)	TABLE ANGLE (Degree)	RAW VALUE (dBuV)	CORRECTION FACTOR (dB/m)
1	2390.00	70.1 PK	74.0	-3.9	1.60 H	274	37.3	32.8
2	2390.00	52.7 AV	54.0	-1.3	1.60 H	274	19.9	32.8
3	*2422.00	104.6 PK			2.06 H	280	71.7	32.9
4	*2422.00	100.4 AV			2.06 H	280	67.5	32.9
5	4844.00	46.8 PK	74.0	-27.2	2.54 H	198	41.0	5.8
6	4844.00	33.6 AV	54.0	-20.4	2.54 H	198	27.8	5.8

ANTENNA POLARITY & TEST DISTANCE: VERTICAL AT 3 M

NO.	FREQ. (MHz)	EMISSION LEVEL (dBuV/m)	LIMIT (dBuV/m)	MARGIN (dB)	ANTENNA HEIGHT (m)	TABLE ANGLE (Degree)	RAW VALUE (dBuV)	CORRECTION FACTOR (dB/m)
1	2390.00	70.7 PK	74.0	-3.3	1.74 V	356	37.9	32.8
2	2390.00	50.5 AV	54.0	-3.5	1.74 V	356	17.7	32.8
3	*2422.00	104.5 PK			1.75 V	349	71.6	32.9
4	*2422.00	99.3 AV			1.75 V	349	66.4	32.9
5	4844.00	46.8 PK	74.0	-27.2	1.58 V	294	41.0	5.8
6	4844.00	33.9 AV	54.0	-20.1	1.58 V	294	28.1	5.8

Remarks:

1. Emission Level(dBuV/m) = Raw Value(dBuV) + Correction Factor(dB/m)
2. Correction Factor(dB/m) = Antenna Factor(dB/m) + Cable Factor(dB)
3. The other emission levels were very low against the limit.
4. Margin value = Emission Level – Limit value
5. " * ": Fundamental frequency.

CHANNEL	TX Channel 6	DETECTOR FUNCTION	Peak (PK)
FREQUENCY RANGE	1GHz ~ 25GHz		Average (AV)

ANTENNA POLARITY & TEST DISTANCE: HORIZONTAL AT 3 M

NO.	FREQ. (MHz)	EMISSION LEVEL (dBuV/m)	LIMIT (dBuV/m)	MARGIN (dB)	ANTENNA HEIGHT (m)	TABLE ANGLE (Degree)	RAW VALUE (dBuV)	CORRECTION FACTOR (dB/m)
1	2390.00	67.0 PK	74.0	-7.0	1.51 H	284	34.2	32.8
2	2390.00	48.4 AV	54.0	-5.6	1.51 H	284	15.6	32.8
3	*2437.00	106.6 PK			1.80 H	281	73.7	32.9
4	*2437.00	96.8 AV			1.80 H	281	63.9	32.9
5	2483.50	67.1 PK	74.0	-6.9	1.58 H	292	34.1	33.0
6	2483.50	48.6 AV	54.0	-5.4	1.58 H	292	15.6	33.0
7	4874.00	47.1 PK	74.0	-26.9	1.45 H	124	41.1	6.0
8	4874.00	34.1 AV	54.0	-19.9	1.45 H	124	28.1	6.0

ANTENNA POLARITY & TEST DISTANCE: VERTICAL AT 3 M

NO.	FREQ. (MHz)	EMISSION LEVEL (dBuV/m)	LIMIT (dBuV/m)	MARGIN (dB)	ANTENNA HEIGHT (m)	TABLE ANGLE (Degree)	RAW VALUE (dBuV)	CORRECTION FACTOR (dB/m)
1	2390.00	62.7 PK	74.0	-11.3	1.90 V	45	29.9	32.8
2	2390.00	47.6 AV	54.0	-6.4	1.90 V	45	14.8	32.8
3	*2437.00	106.2 PK			2.40 V	346	73.3	32.9
4	*2437.00	101.1 AV			2.40 V	346	68.2	32.9
5	2483.50	67.2 PK	74.0	-6.8	1.92 V	331	34.2	33.0
6	2483.50	48.0 AV	54.0	-6.0	1.92 V	331	15.0	33.0
7	4874.00	47.5 PK	74.0	-26.5	1.69 V	74	41.5	6.0
8	4874.00	34.5 AV	54.0	-19.5	1.69 V	74	28.5	6.0

Remarks:

1. Emission Level(dBuV/m) = Raw Value(dBuV) + Correction Factor(dB/m)
2. Correction Factor(dB/m) = Antenna Factor(dB/m) + Cable Factor(dB)
3. The other emission levels were very low against the limit.
4. Margin value = Emission Level – Limit value
5. " * ": Fundamental frequency.

CHANNEL	TX Channel 9	DETECTOR	Peak (PK)
FREQUENCY RANGE	1GHz ~ 25GHz	FUNCTION	Average (AV)

ANTENNA POLARITY & TEST DISTANCE: HORIZONTAL AT 3 M

NO.	FREQ. (MHz)	EMISSION LEVEL (dBuV/m)	LIMIT (dBuV/m)	MARGIN (dB)	ANTENNA HEIGHT (m)	TABLE ANGLE (Degree)	RAW VALUE (dBuV)	CORRECTION FACTOR (dB/m)
1	*2452.00	104.2 PK			1.33 H	283	71.2	33.0
2	*2452.00	100.8 AV			1.33 H	283	67.8	33.0
3	2483.50	72.6 PK	74.0	-1.4	1.34 H	259	39.6	33.0
4	2483.50	49.6 AV	54.0	-4.4	1.34 H	259	16.6	33.0
5	4904.00	48.4 PK	74.0	-25.6	1.85 H	354	42.5	5.9
6	4904.00	34.9 AV	54.0	-19.1	1.85 H	354	29.0	5.9

ANTENNA POLARITY & TEST DISTANCE: VERTICAL AT 3 M

NO.	FREQ. (MHz)	EMISSION LEVEL (dBuV/m)	LIMIT (dBuV/m)	MARGIN (dB)	ANTENNA HEIGHT (m)	TABLE ANGLE (Degree)	RAW VALUE (dBuV)	CORRECTION FACTOR (dB/m)
1	*2452.00	104.0 PK			2.08 V	347	71.0	33.0
2	*2452.00	98.5 AV			2.08 V	347	65.5	33.0
3	2483.50	67.7 PK	74.0	-6.3	1.51 V	238	34.7	33.0
4	2483.50	49.8 AV	54.0	-4.2	1.51 V	238	16.8	33.0
5	4904.00	47.8 PK	74.0	-26.2	1.49 V	105	41.9	5.9
6	4904.00	35.1 AV	54.0	-18.9	1.49 V	105	29.2	5.9

Remarks:

1. Emission Level(dBuV/m) = Raw Value(dBuV) + Correction Factor(dB/m)
2. Correction Factor(dB/m) = Antenna Factor(dB/m) + Cable Factor(dB)
3. The other emission levels were very low against the limit.
4. Margin value = Emission Level – Limit value
5. " * ": Fundamental frequency.

Radio 3: CDD Mode

802.11b

CHANNEL	TX Channel 1	DETECTOR FUNCTION	Peak (PK)
FREQUENCY RANGE	1GHz ~ 25GHz		Average (AV)

ANTENNA POLARITY & TEST DISTANCE: HORIZONTAL AT 3 M								
NO.	FREQ. (MHz)	EMISSION LEVEL (dBuV/m)	LIMIT (dBuV/m)	MARGIN (dB)	ANTENNA HEIGHT (m)	TABLE ANGLE (Degree)	RAW VALUE (dBuV)	CORRECTION FACTOR (dB/m)
1	2390.00	56.8 PK	74.0	-17.2	1.77 H	187	24.0	32.8
2	2390.00	45.3 AV	54.0	-8.7	1.77 H	187	12.5	32.8
3	*2412.00	99.3 PK			1.69 H	215	66.4	32.9
4	*2412.00	97.0 AV			1.69 H	215	64.1	32.9
5	4824.00	56.9 PK	74.0	-17.1	1.65 H	42	51.0	5.9
6	4824.00	52.3 AV	54.0	-1.7	1.65 H	42	46.4	5.9

ANTENNA POLARITY & TEST DISTANCE: VERTICAL AT 3 M								
NO.	FREQ. (MHz)	EMISSION LEVEL (dBuV/m)	LIMIT (dBuV/m)	MARGIN (dB)	ANTENNA HEIGHT (m)	TABLE ANGLE (Degree)	RAW VALUE (dBuV)	CORRECTION FACTOR (dB/m)
1	2390.00	57.4 PK	74.0	-16.6	2.89 V	140	24.6	32.8
2	2390.00	45.1 AV	54.0	-8.9	2.89 V	140	12.3	32.8
3	*2412.00	100.4 PK			3.16 V	105	67.5	32.9
4	*2412.00	98.1 AV			3.16 V	105	65.2	32.9
5	4824.00	54.8 PK	74.0	-19.2	1.38 V	35	48.9	5.9
6	4824.00	50.7 AV	54.0	-3.3	1.38 V	35	44.8	5.9

Remarks:

1. Emission Level(dBuV/m) = Raw Value(dBuV) + Correction Factor(dB/m)
2. Correction Factor(dB/m) = Antenna Factor(dB/m) + Cable Factor(dB)
3. The other emission levels were very low against the limit.
4. Margin value = Emission Level – Limit value
5. " * ": Fundamental frequency.

CHANNEL	TX Channel 6	DETECTOR FUNCTION	Peak (PK)
FREQUENCY RANGE	1GHz ~ 25GHz		Average (AV)

ANTENNA POLARITY & TEST DISTANCE: HORIZONTAL AT 3 M

NO.	FREQ. (MHz)	EMISSION LEVEL (dBuV/m)	LIMIT (dBuV/m)	MARGIN (dB)	ANTENNA HEIGHT (m)	TABLE ANGLE (Degree)	RAW VALUE (dBuV)	CORRECTION FACTOR (dB/m)
1	*2437.00	99.8 PK			2.82 H	52	66.9	32.9
2	*2437.00	97.5 AV			2.82 H	52	64.6	32.9
3	4874.00	57.7 PK	74.0	-16.3	2.05 H	328	51.7	6.0
4	4874.00	52.7 AV	54.0	-1.3	2.05 H	328	46.7	6.0

ANTENNA POLARITY & TEST DISTANCE: VERTICAL AT 3 M

NO.	FREQ. (MHz)	EMISSION LEVEL (dBuV/m)	LIMIT (dBuV/m)	MARGIN (dB)	ANTENNA HEIGHT (m)	TABLE ANGLE (Degree)	RAW VALUE (dBuV)	CORRECTION FACTOR (dB/m)
1	*2437.00	99.2 PK			2.48 V	105	66.3	32.9
2	*2437.00	96.8 AV			2.48 V	105	63.9	32.9
3	4874.00	54.8 PK	74.0	-19.2	2.45 V	333	48.8	6.0
4	4874.00	50.8 AV	54.0	-3.2	2.45 V	333	44.8	6.0

Remarks:

1. Emission Level(dBuV/m) = Raw Value(dBuV) + Correction Factor(dB/m)
2. Correction Factor(dB/m) = Antenna Factor(dB/m) + Cable Factor(dB)
3. The other emission levels were very low against the limit.
4. Margin value = Emission Level – Limit value
5. " * ": Fundamental frequency.

CHANNEL	TX Channel 11	DETECTOR FUNCTION	Peak (PK)
FREQUENCY RANGE	1GHz ~ 25GHz		Average (AV)

ANTENNA POLARITY & TEST DISTANCE: HORIZONTAL AT 3 M								
NO.	FREQ. (MHz)	EMISSION LEVEL (dBuV/m)	LIMIT (dBuV/m)	MARGIN (dB)	ANTENNA HEIGHT (m)	TABLE ANGLE (Degree)	RAW VALUE (dBuV)	CORRECTION FACTOR (dB/m)
1	*2462.00	98.4 PK			1.81 H	141	65.5	32.9
2	*2462.00	96.1 AV			1.81 H	141	63.2	32.9
3	2483.50	56.8 PK	74.0	-17.2	1.73 H	104	23.8	33.0
4	2483.50	45.2 AV	54.0	-8.8	1.73 H	104	12.2	33.0
5	4924.00	55.2 PK	74.0	-18.8	2.06 H	336	49.2	6.0
6	4924.00	52.4 AV	54.0	-1.6	2.06 H	336	46.4	6.0

ANTENNA POLARITY & TEST DISTANCE: VERTICAL AT 3 M								
NO.	FREQ. (MHz)	EMISSION LEVEL (dBuV/m)	LIMIT (dBuV/m)	MARGIN (dB)	ANTENNA HEIGHT (m)	TABLE ANGLE (Degree)	RAW VALUE (dBuV)	CORRECTION FACTOR (dB/m)
1	*2462.00	97.8 PK			3.02 V	104	64.9	32.9
2	*2462.00	95.5 AV			3.02 V	104	62.6	32.9
3	2483.50	56.5 PK	74.0	-17.5	2.84 V	85	23.5	33.0
4	2483.50	45.1 AV	54.0	-8.9	2.84 V	85	12.1	33.0
5	4924.00	55.6 PK	74.0	-18.4	2.54 V	327	49.6	6.0
6	4924.00	51.6 AV	54.0	-2.4	2.54 V	327	45.6	6.0

Remarks:

1. Emission Level(dBuV/m) = Raw Value(dBuV) + Correction Factor(dB/m)
2. Correction Factor(dB/m) = Antenna Factor(dB/m) + Cable Factor(dB)
3. The other emission levels were very low against the limit.
4. Margin value = Emission Level – Limit value
5. " * ": Fundamental frequency.

802.11g

CHANNEL	TX Channel 1	DETECTOR FUNCTION	Peak (PK)
FREQUENCY RANGE	1GHz ~ 25GHz		Average (AV)

ANTENNA POLARITY & TEST DISTANCE: HORIZONTAL AT 3 M

NO.	FREQ. (MHz)	EMISSION LEVEL (dBuV/m)	LIMIT (dBuV/m)	MARGIN (dB)	ANTENNA HEIGHT (m)	TABLE ANGLE (Degree)	RAW VALUE (dBuV)	CORRECTION FACTOR (dB/m)
1	2390.00	65.9 PK	74.0	-8.1	2.11 H	56	33.1	32.8
2	2390.00	52.7 AV	54.0	-1.3	2.11 H	56	19.9	32.8
3	*2412.00	103.7 PK			2.13 H	139	70.8	32.9
4	*2412.00	93.6 AV			2.13 H	139	60.7	32.9
5	4824.00	55.5 PK	74.0	-18.5	2.08 H	324	49.6	5.9
6	4824.00	42.6 AV	54.0	-11.4	2.08 H	324	36.7	5.9

ANTENNA POLARITY & TEST DISTANCE: VERTICAL AT 3 M

NO.	FREQ. (MHz)	EMISSION LEVEL (dBuV/m)	LIMIT (dBuV/m)	MARGIN (dB)	ANTENNA HEIGHT (m)	TABLE ANGLE (Degree)	RAW VALUE (dBuV)	CORRECTION FACTOR (dB/m)
1	2390.00	65.1 PK	74.0	-8.9	2.33 V	107	32.3	32.8
2	2390.00	51.6 AV	54.0	-2.4	2.33 V	107	18.8	32.8
3	*2412.00	104.1 PK			2.85 V	107	71.2	32.9
4	*2412.00	94.0 AV			2.85 V	107	61.1	32.9
5	4824.00	53.5 PK	74.0	-20.5	3.70 V	17	47.6	5.9
6	4824.00	41.4 AV	54.0	-12.6	3.70 V	17	35.5	5.9

Remarks:

1. Emission Level(dBuV/m) = Raw Value(dBuV) + Correction Factor(dB/m)
2. Correction Factor(dB/m) = Antenna Factor(dB/m) + Cable Factor(dB)
3. The other emission levels were very low against the limit.
4. Margin value = Emission Level – Limit value
5. " * ": Fundamental frequency.

CHANNEL	TX Channel 6	DETECTOR FUNCTION	Peak (PK)
FREQUENCY RANGE	1GHz ~ 25GHz		Average (AV)

ANTENNA POLARITY & TEST DISTANCE: HORIZONTAL AT 3 M

NO.	FREQ. (MHz)	EMISSION LEVEL (dBuV/m)	LIMIT (dBuV/m)	MARGIN (dB)	ANTENNA HEIGHT (m)	TABLE ANGLE (Degree)	RAW VALUE (dBuV)	CORRECTION FACTOR (dB/m)
1	2390.00	56.4 PK	74.0	-17.6	2.20 H	50	23.6	32.8
2	2390.00	47.1 AV	54.0	-6.9	2.20 H	50	14.3	32.8
3	*2437.00	108.5 PK			2.41 H	47	75.6	32.9
4	*2437.00	98.3 AV			2.41 H	47	65.4	32.9
5	4874.00	56.3 PK	74.0	-17.7	1.75 H	318	50.3	6.0
6	4874.00	43.5 AV	54.0	-10.5	1.75 H	318	37.5	6.0

ANTENNA POLARITY & TEST DISTANCE: VERTICAL AT 3 M

NO.	FREQ. (MHz)	EMISSION LEVEL (dBuV/m)	LIMIT (dBuV/m)	MARGIN (dB)	ANTENNA HEIGHT (m)	TABLE ANGLE (Degree)	RAW VALUE (dBuV)	CORRECTION FACTOR (dB/m)
1	2390.00	57.5 PK	74.0	-16.5	2.64 V	107	24.7	32.8
2	2390.00	46.9 AV	54.0	-7.1	2.64 V	107	14.1	32.8
3	*2437.00	106.2 PK			2.85 V	93	73.3	32.9
4	*2437.00	96.6 AV			2.85 V	93	63.7	32.9
5	4874.00	55.4 PK	74.0	-18.6	3.94 V	23	49.4	6.0
6	4874.00	43.2 AV	54.0	-10.8	3.94 V	23	37.2	6.0

Remarks:

1. Emission Level(dBuV/m) = Raw Value(dBuV) + Correction Factor(dB/m)
2. Correction Factor(dB/m) = Antenna Factor(dB/m) + Cable Factor(dB)
3. The other emission levels were very low against the limit.
4. Margin value = Emission Level – Limit value
5. " * ": Fundamental frequency.

CHANNEL	TX Channel 11	DETECTOR FUNCTION	Peak (PK)
FREQUENCY RANGE	1GHz ~ 25GHz		Average (AV)

ANTENNA POLARITY & TEST DISTANCE: HORIZONTAL AT 3 M								
NO.	FREQ. (MHz)	EMISSION LEVEL (dBuV/m)	LIMIT (dBuV/m)	MARGIN (dB)	ANTENNA HEIGHT (m)	TABLE ANGLE (Degree)	RAW VALUE (dBuV)	CORRECTION FACTOR (dB/m)
1	*2462.00	105.9 PK			2.18 H	52	73.0	32.9
2	*2462.00	95.9 AV			2.18 H	52	63.0	32.9
3	2483.50	65.4 PK	74.0	-8.6	2.73 H	54	32.4	33.0
4	2483.50	52.3 AV	54.0	-1.7	2.73 H	54	19.3	33.0
5	4924.00	57.6 PK	74.0	-16.4	2.07 H	326	51.6	6.0
6	4924.00	44.9 AV	54.0	-9.1	2.07 H	326	38.9	6.0
ANTENNA POLARITY & TEST DISTANCE: VERTICAL AT 3 M								
NO.	FREQ. (MHz)	EMISSION LEVEL (dBuV/m)	LIMIT (dBuV/m)	MARGIN (dB)	ANTENNA HEIGHT (m)	TABLE ANGLE (Degree)	RAW VALUE (dBuV)	CORRECTION FACTOR (dB/m)
1	*2462.00	103.1 PK			2.01 V	97	70.2	32.9
2	*2462.00	93.0 AV			2.01 V	97	60.1	32.9
3	2483.50	61.9 PK	74.0	-12.1	2.30 V	109	28.9	33.0
4	2483.50	49.7 AV	54.0	-4.3	2.30 V	109	16.7	33.0
5	4924.00	54.6 PK	74.0	-19.4	3.60 V	15	48.6	6.0
6	4924.00	43.5 AV	54.0	-10.5	3.60 V	15	37.5	6.0

Remarks:

1. Emission Level(dBuV/m) = Raw Value(dBuV) + Correction Factor(dB/m)
2. Correction Factor(dB/m) = Antenna Factor(dB/m) + Cable Factor(dB)
3. The other emission levels were very low against the limit.
4. Margin value = Emission Level – Limit value
5. " * ": Fundamental frequency.

802.11n (HT20)

CHANNEL	TX Channel 1	DETECTOR FUNCTION	Peak (PK)
FREQUENCY RANGE	1GHz ~ 25GHz		Average (AV)

ANTENNA POLARITY & TEST DISTANCE: HORIZONTAL AT 3 M

NO.	FREQ. (MHz)	EMISSION LEVEL (dBuV/m)	LIMIT (dBuV/m)	MARGIN (dB)	ANTENNA HEIGHT (m)	TABLE ANGLE (Degree)	RAW VALUE (dBuV)	CORRECTION FACTOR (dB/m)
1	2390.00	66.9 PK	74.0	-7.1	2.12 H	54	34.1	32.8
2	2390.00	52.7 AV	54.0	-1.3	2.12 H	54	19.9	32.8
3	*2412.00	102.6 PK			2.36 H	54	69.7	32.9
4	*2412.00	93.0 AV			2.36 H	54	60.1	32.9
5	4824.00	56.3 PK	74.0	-17.7	2.09 H	323	50.4	5.9
6	4824.00	41.9 AV	54.0	-12.1	2.09 H	323	36.0	5.9

ANTENNA POLARITY & TEST DISTANCE: VERTICAL AT 3 M

NO.	FREQ. (MHz)	EMISSION LEVEL (dBuV/m)	LIMIT (dBuV/m)	MARGIN (dB)	ANTENNA HEIGHT (m)	TABLE ANGLE (Degree)	RAW VALUE (dBuV)	CORRECTION FACTOR (dB/m)
1	2390.00	64.1 PK	74.0	-9.9	2.91 V	109	31.3	32.8
2	2390.00	50.6 AV	54.0	-3.4	2.91 V	109	17.8	32.8
3	*2412.00	102.6 PK			3.49 V	106	69.7	32.9
4	*2412.00	92.9 AV			3.49 V	106	60.0	32.9
5	4824.00	57.0 PK	74.0	-17.0	2.97 V	334	51.1	5.9
6	4824.00	42.7 AV	54.0	-11.3	2.97 V	334	36.8	5.9

Remarks:

1. Emission Level(dBuV/m) = Raw Value(dBuV) + Correction Factor(dB/m)
2. Correction Factor(dB/m) = Antenna Factor(dB/m) + Cable Factor(dB)
3. The other emission levels were very low against the limit.
4. Margin value = Emission Level – Limit value
5. " * ": Fundamental frequency.

CHANNEL	TX Channel 6	DETECTOR FUNCTION	Peak (PK)
FREQUENCY RANGE	1GHz ~ 25GHz		Average (AV)

ANTENNA POLARITY & TEST DISTANCE: HORIZONTAL AT 3 M

NO.	FREQ. (MHz)	EMISSION LEVEL (dBuV/m)	LIMIT (dBuV/m)	MARGIN (dB)	ANTENNA HEIGHT (m)	TABLE ANGLE (Degree)	RAW VALUE (dBuV)	CORRECTION FACTOR (dB/m)
1	*2437.00	108.1 PK			2.90 H	56	75.2	32.9
2	*2437.00	98.1 AV			2.90 H	56	65.2	32.9
3	4874.00	56.8 PK	74.0	-17.2	1.76 H	41	50.8	6.0
4	4874.00	45.1 AV	54.0	-8.9	1.76 H	41	39.1	6.0

ANTENNA POLARITY & TEST DISTANCE: VERTICAL AT 3 M

NO.	FREQ. (MHz)	EMISSION LEVEL (dBuV/m)	LIMIT (dBuV/m)	MARGIN (dB)	ANTENNA HEIGHT (m)	TABLE ANGLE (Degree)	RAW VALUE (dBuV)	CORRECTION FACTOR (dB/m)
1	*2437.00	106.8 PK			3.06 V	105	73.9	32.9
2	*2437.00	96.5 AV			3.06 V	105	63.6	32.9
3	4874.00	55.4 PK	74.0	-18.6	2.65 V	337	49.4	6.0
4	4874.00	42.7 AV	54.0	-11.3	2.65 V	337	36.7	6.0

Remarks:

1. Emission Level(dBuV/m) = Raw Value(dBuV) + Correction Factor(dB/m)
2. Correction Factor(dB/m) = Antenna Factor(dB/m) + Cable Factor(dB)
3. The other emission levels were very low against the limit.
4. Margin value = Emission Level – Limit value
5. " * ": Fundamental frequency.

CHANNEL	TX Channel 11	DETECTOR FUNCTION	Peak (PK)
FREQUENCY RANGE	1GHz ~ 25GHz		Average (AV)

ANTENNA POLARITY & TEST DISTANCE: HORIZONTAL AT 3 M								
NO.	FREQ. (MHz)	EMISSION LEVEL (dBuV/m)	LIMIT (dBuV/m)	MARGIN (dB)	ANTENNA HEIGHT (m)	TABLE ANGLE (Degree)	RAW VALUE (dBuV)	CORRECTION FACTOR (dB/m)
1	*2462.00	103.3 PK			3.05 H	48	70.4	32.9
2	*2462.00	93.8 AV			3.05 H	48	60.9	32.9
3	2483.50	67.1 PK	74.0	-6.9	3.00 H	51	34.1	33.0
4	2483.50	52.5 AV	54.0	-1.5	3.00 H	51	19.5	33.0
5	4924.00	56.6 PK	74.0	-17.4	1.90 H	40	50.6	6.0
6	4924.00	43.4 AV	54.0	-10.6	1.90 H	40	37.4	6.0
ANTENNA POLARITY & TEST DISTANCE: VERTICAL AT 3 M								
NO.	FREQ. (MHz)	EMISSION LEVEL (dBuV/m)	LIMIT (dBuV/m)	MARGIN (dB)	ANTENNA HEIGHT (m)	TABLE ANGLE (Degree)	RAW VALUE (dBuV)	CORRECTION FACTOR (dB/m)
1	*2462.00	102.6 PK			3.03 V	107	69.7	32.9
2	*2462.00	92.5 AV			3.03 V	107	59.6	32.9
3	2483.50	61.2 PK	74.0	-12.8	2.59 V	315	28.2	33.0
4	2483.50	48.1 AV	54.0	-5.9	2.59 V	315	15.1	33.0
5	4924.00	57.6 PK	74.0	-16.4	3.00 V	326	51.6	6.0
6	4924.00	43.6 AV	54.0	-10.4	3.00 V	326	37.6	6.0

Remarks:

1. Emission Level(dBuV/m) = Raw Value(dBuV) + Correction Factor(dB/m)
2. Correction Factor(dB/m) = Antenna Factor(dB/m) + Cable Factor(dB)
3. The other emission levels were very low against the limit.
4. Margin value = Emission Level – Limit value
5. " * ": Fundamental frequency.

802.11n (HT40)

CHANNEL	TX Channel 3	DETECTOR FUNCTION	Peak (PK)
FREQUENCY RANGE	1GHz ~ 25GHz		Average (AV)

ANTENNA POLARITY & TEST DISTANCE: HORIZONTAL AT 3 M

NO.	FREQ. (MHz)	EMISSION LEVEL (dBuV/m)	LIMIT (dBuV/m)	MARGIN (dB)	ANTENNA HEIGHT (m)	TABLE ANGLE (Degree)	RAW VALUE (dBuV)	CORRECTION FACTOR (dB/m)
1	2390.00	64.3 PK	74.0	-9.7	1.86 H	148	31.5	32.8
2	2390.00	52.4 AV	54.0	-1.6	1.86 H	148	19.6	32.8
3	*2422.00	97.0 PK			1.46 H	148	64.1	32.9
4	*2422.00	87.3 AV			1.46 H	148	54.4	32.9
5	4844.00	49.4 PK	74.0	-24.6	1.93 H	326	43.6	5.8
6	4844.00	37.5 AV	54.0	-16.5	1.93 H	326	31.7	5.8

ANTENNA POLARITY & TEST DISTANCE: VERTICAL AT 3 M

NO.	FREQ. (MHz)	EMISSION LEVEL (dBuV/m)	LIMIT (dBuV/m)	MARGIN (dB)	ANTENNA HEIGHT (m)	TABLE ANGLE (Degree)	RAW VALUE (dBuV)	CORRECTION FACTOR (dB/m)
1	2390.00	62.0 PK	74.0	-12.0	2.88 V	109	29.2	32.8
2	2390.00	50.4 AV	54.0	-3.6	2.88 V	109	17.6	32.8
3	*2422.00	95.7 PK			3.12 V	111	62.8	32.9
4	*2422.00	86.1 AV			3.12 V	111	53.2	32.9
5	4844.00	49.4 PK	74.0	-24.6	2.87 V	331	43.6	5.8
6	4844.00	37.3 AV	54.0	-16.7	2.87 V	331	31.5	5.8

Remarks:

1. Emission Level(dBuV/m) = Raw Value(dBuV) + Correction Factor(dB/m)
2. Correction Factor(dB/m) = Antenna Factor(dB/m) + Cable Factor(dB)
3. The other emission levels were very low against the limit.
4. Margin value = Emission Level – Limit value
5. " * ": Fundamental frequency.

CHANNEL	TX Channel 6	DETECTOR FUNCTION	Peak (PK)
FREQUENCY RANGE	1GHz ~ 25GHz		Average (AV)

ANTENNA POLARITY & TEST DISTANCE: HORIZONTAL AT 3 M

NO.	FREQ. (MHz)	EMISSION LEVEL (dBuV/m)	LIMIT (dBuV/m)	MARGIN (dB)	ANTENNA HEIGHT (m)	TABLE ANGLE (Degree)	RAW VALUE (dBuV)	CORRECTION FACTOR (dB/m)
1	2390.00	65.2 PK	74.0	-8.8	2.11 H	54	32.4	32.8
2	2390.00	52.4 AV	54.0	-1.6	2.11 H	54	19.6	32.8
3	*2437.00	102.6 PK			1.90 H	52	69.7	32.9
4	*2437.00	93.3 AV			1.90 H	52	60.4	32.9
5	2483.50	64.6 PK	74.0	-9.4	2.14 H	52	31.6	33.0
6	2483.50	51.1 AV	54.0	-2.9	2.14 H	52	18.1	33.0
7	4874.00	54.2 PK	74.0	-19.8	2.07 H	327	48.2	6.0
8	4874.00	41.6 AV	54.0	-12.4	2.07 H	327	35.6	6.0

ANTENNA POLARITY & TEST DISTANCE: VERTICAL AT 3 M

NO.	FREQ. (MHz)	EMISSION LEVEL (dBuV/m)	LIMIT (dBuV/m)	MARGIN (dB)	ANTENNA HEIGHT (m)	TABLE ANGLE (Degree)	RAW VALUE (dBuV)	CORRECTION FACTOR (dB/m)
1	2390.00	62.7 PK	74.0	-11.3	3.52 V	99	29.9	32.8
2	2390.00	50.0 AV	54.0	-4.0	3.52 V	99	17.2	32.8
3	*2437.00	100.4 PK			2.30 V	112	67.5	32.9
4	*2437.00	90.6 AV			2.30 V	112	57.7	32.9
5	2483.50	60.7 PK	74.0	-13.3	2.50 V	110	27.7	33.0
6	2483.50	49.4 AV	54.0	-4.6	2.50 V	110	16.4	33.0
7	4874.00	54.4 PK	74.0	-19.6	2.32 V	345	48.4	6.0
8	4874.00	41.6 AV	54.0	-12.4	2.32 V	345	35.6	6.0

Remarks:

1. Emission Level(dBuV/m) = Raw Value(dBuV) + Correction Factor(dB/m)
2. Correction Factor(dB/m) = Antenna Factor(dB/m) + Cable Factor(dB)
3. The other emission levels were very low against the limit.
4. Margin value = Emission Level – Limit value
5. " * ": Fundamental frequency.

CHANNEL	TX Channel 9	DETECTOR	Peak (PK)
FREQUENCY RANGE	1GHz ~ 25GHz	FUNCTION	Average (AV)

ANTENNA POLARITY & TEST DISTANCE: HORIZONTAL AT 3 M

NO.	FREQ. (MHz)	EMISSION LEVEL (dBuV/m)	LIMIT (dBuV/m)	MARGIN (dB)	ANTENNA HEIGHT (m)	TABLE ANGLE (Degree)	RAW VALUE (dBuV)	CORRECTION FACTOR (dB/m)
1	*2452.00	99.9 PK			1.87 H	145	66.9	33.0
2	*2452.00	90.0 AV			1.87 H	145	57.0	33.0
3	2483.50	64.6 PK	74.0	-9.4	2.24 H	145	31.6	33.0
4	2483.50	52.4 AV	54.0	-1.6	2.24 H	145	19.4	33.0
5	4904.00	52.4 PK	74.0	-21.6	1.98 H	331	46.5	5.9
6	4904.00	40.7 AV	54.0	-13.3	1.98 H	331	34.8	5.9

ANTENNA POLARITY & TEST DISTANCE: VERTICAL AT 3 M

NO.	FREQ. (MHz)	EMISSION LEVEL (dBuV/m)	LIMIT (dBuV/m)	MARGIN (dB)	ANTENNA HEIGHT (m)	TABLE ANGLE (Degree)	RAW VALUE (dBuV)	CORRECTION FACTOR (dB/m)
1	*2452.00	98.9 PK			3.33 V	102	65.9	33.0
2	*2452.00	89.1 AV			3.33 V	102	56.1	33.0
3	2483.50	61.7 PK	74.0	-12.3	2.47 V	103	28.7	33.0
4	2483.50	51.0 AV	54.0	-3.0	2.47 V	103	18.0	33.0
5	4904.00	51.2 PK	74.0	-22.8	2.85 V	333	45.3	5.9
6	4904.00	39.4 AV	54.0	-14.6	2.85 V	333	33.5	5.9

Remarks:

1. Emission Level(dBuV/m) = Raw Value(dBuV) + Correction Factor(dB/m)
2. Correction Factor(dB/m) = Antenna Factor(dB/m) + Cable Factor(dB)
3. The other emission levels were very low against the limit.
4. Margin value = Emission Level – Limit value
5. " * ": Fundamental frequency.

Below 1GHz worst-case data:

Radio 1: CDD Mode

802.11b

CHANNEL	TX Channel 1	DETECTOR FUNCTION	Quasi-Peak (QP)
FREQUENCY RANGE	30MHz ~ 1GHz		

ANTENNA POLARITY & TEST DISTANCE: HORIZONTAL AT 3 M

NO.	FREQ. (MHz)	EMISSION LEVEL (dBuV/m)	LIMIT (dBuV/m)	MARGIN (dB)	ANTENNA HEIGHT (m)	TABLE ANGLE (Degree)	RAW VALUE (dBuV)	CORRECTION FACTOR (dB/m)
1	57.12	31.0 QP	40.0	-9.0	2.00 H	3	45.6	-14.6
2	78.51	31.8 QP	40.0	-8.2	1.49 H	195	50.2	-18.4
3	160.17	35.0 QP	43.5	-8.5	1.49 H	118	48.8	-13.8
4	247.66	28.5 QP	46.0	-17.5	1.00 H	285	42.8	-14.3
5	304.04	40.0 QP	46.0	-6.0	1.00 H	351	52.1	-12.1
6	836.78	37.2 QP	46.0	-8.8	1.00 H	143	38.7	-1.5

ANTENNA POLARITY & TEST DISTANCE: VERTICAL AT 3 M

NO.	FREQ. (MHz)	EMISSION LEVEL (dBuV/m)	LIMIT (dBuV/m)	MARGIN (dB)	ANTENNA HEIGHT (m)	TABLE ANGLE (Degree)	RAW VALUE (dBuV)	CORRECTION FACTOR (dB/m)
1	29.90	33.7 QP	40.0	-6.3	1.00 V	88	49.9	-16.2
2	70.39	36.3 QP	40.0	-3.7	1.49 V	132	52.7	-16.4
3	142.67	30.1 QP	43.5	-13.4	1.00 V	94	44.4	-14.3
4	300.16	29.9 QP	46.0	-16.1	1.49 V	208	42.1	-12.2
5	519.86	26.6 QP	46.0	-19.4	1.00 V	332	34.4	-7.8
6	665.68	27.9 QP	46.0	-18.1	1.49 V	50	32.7	-4.8

Remarks:

1. Emission Level(dBuV/m) = Raw Value(dBuV) + Correction Factor(dB/m)
2. Correction Factor(dB/m) = Antenna Factor(dB/m) + Cable Factor(dB)
3. The other emission levels were very low against the limit.
4. Margin value = Emission Level – Limit value

Radio 3: CDD Mode

802.11b

CHANNEL	TX Channel 1	DETECTOR FUNCTION	Quasi-Peak (QP)
FREQUENCY RANGE	30MHz ~ 1GHz		

ANTENNA POLARITY & TEST DISTANCE: HORIZONTAL AT 3 M								
NO.	FREQ. (MHz)	EMISSION LEVEL (dBuV/m)	LIMIT (dBuV/m)	MARGIN (dB)	ANTENNA HEIGHT (m)	TABLE ANGLE (Degree)	RAW VALUE (dBuV)	CORRECTION FACTOR (dB/m)
1	57.12	31.7 QP	40.0	-8.3	2.00 H	58	46.3	-14.6
2	76.56	31.9 QP	40.0	-8.1	1.50 H	192	49.9	-18.0
3	162.11	33.2 QP	43.5	-10.3	1.50 H	128	47.0	-13.8
4	249.60	26.4 QP	46.0	-19.6	1.01 H	152	40.6	-14.2
5	302.10	36.5 QP	46.0	-9.5	1.01 H	100	48.7	-12.2
6	708.46	36.2 QP	46.0	-9.8	1.50 H	140	40.2	-4.0

ANTENNA POLARITY & TEST DISTANCE: VERTICAL AT 3 M								
NO.	FREQ. (MHz)	EMISSION LEVEL (dBuV/m)	LIMIT (dBuV/m)	MARGIN (dB)	ANTENNA HEIGHT (m)	TABLE ANGLE (Degree)	RAW VALUE (dBuV)	CORRECTION FACTOR (dB/m)
1	30.90	31.3 QP	40.0	-8.7	1.00 V	318	47.5	-16.2
2	69.05	37.8 QP	40.0	-2.2	1.00 V	153	54.0	-16.2
3	142.67	28.9 QP	43.5	-14.6	1.00 V	116	43.2	-14.3
4	302.10	28.3 QP	46.0	-17.7	2.00 V	3	40.5	-12.2
5	521.81	25.5 QP	46.0	-20.5	1.00 V	342	33.3	-7.8
6	708.46	36.6 QP	46.0	-9.4	1.50 V	173	40.6	-4.0

Remarks:

1. Emission Level(dBuV/m) = Raw Value(dBuV) + Correction Factor(dB/m)
2. Correction Factor(dB/m) = Antenna Factor(dB/m) + Cable Factor(dB)
3. The other emission levels were very low against the limit.
4. Margin value = Emission Level – Limit value

4.2 Conducted Emission Measurement

4.2.1 Limits of Conducted Emission Measurement

Frequency (MHz)	Conducted Limit (dBuV)	
	Quasi-peak	Average
0.15 - 0.5	66 - 56	56 - 46
0.50 - 5.0	56	46
5.0 - 30.0	60	50

- Note:** 1. The lower limit shall apply at the transition frequencies.
 2. The limit decreases in line with the logarithm of the frequency in the range of 0.15 to 0.50MHz.

4.2.2 Test Instruments

Description & Manufacturer	Model No.	Serial No.	Cal. Date	Cal. Due
Test Receiver ROHDE & SCHWARZ	ESCI	100613	Nov. 16, 2015	Nov. 15, 2016
RF signal cable (with 10dB PAD) Woken	5D-FB	Cable-cond1-01	Dec. 26, 2015	Dec. 25, 2016
LISN/AMN ROHDE & SCHWARZ (EUT)	ESH3-Z5	835239/001	Feb. 26, 2016	Feb. 25, 2017
LISN/AMN ROHDE & SCHWARZ (Peripheral)	ESH3-Z5	100220	Nov. 13, 2015	Nov. 12, 2016
Software ADT	BV ADT_Cond_ V7.3.7.3	NA	NA	NA

- Note:** 1. The calibration interval of the above test instruments is 12 months and the calibrations are traceable to NML/ROC and NIST/USA.
 2. The test was performed in HwaYa Shielded Room 1.
 3. The VCCI Site Registration No. is C-2040.

4.2.3 Test Procedures

- The EUT was placed 0.4 meters from the conducting wall of the shielded room with EUT being connected to the power mains through a line impedance stabilization network (LISN). Other support units were connected to the power mains through another LISN. The two LISNs provide 50 ohm/ 50uH of coupling impedance for the measuring instrument.
- Both lines of the power mains connected to the EUT were checked for maximum conducted interference.
- The frequency range from 150kHz to 30MHz was searched. Emission levels under (Limit - 20dB) was not recorded.

Note: The resolution bandwidth and video bandwidth of test receiver is 9kHz for quasi-peak detection (QP) and average detection (AV) at frequency 0.15MHz-30MHz.

4.2.4 Deviation from Test Standard

No deviation.

4.2.5 Test Setup

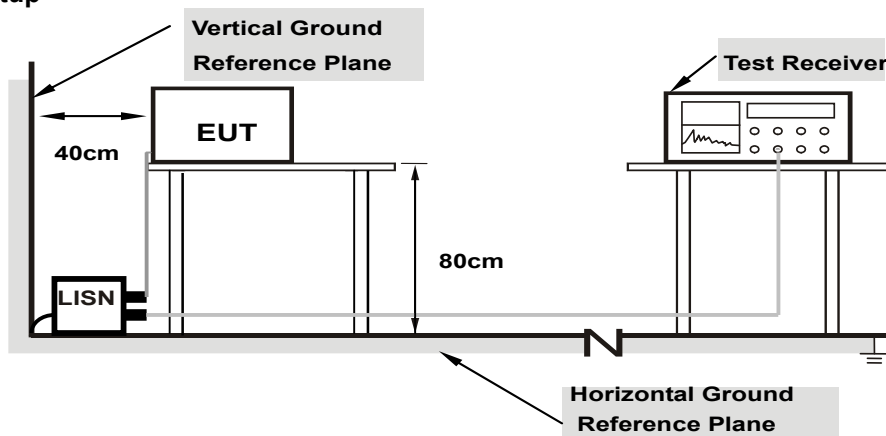

Note: 1.Support units were connected to second LISN.

For the actual test configuration, please refer to the attached file (Test Setup Photo).

4.2.6 EUT Operating Conditions

Same as 4.1.6.

4.2.7 Test Results

Radio 1: CDD Mode

Phase	Line (L)	Detector Function	Quasi-Peak (QP) / Average (AV)
-------	----------	-------------------	--------------------------------

No	Freq. [MHz]	Corr. Factor (dB)	Reading Value [dB (uV)]		Emission Level [dB (uV)]		Limit [dB (uV)]		Margin (dB)	
			Q.P.	AV.	Q.P.	AV.	Q.P.	AV.	Q.P.	AV.
			1	0.16173	10.08	27.96	20.31	38.04	30.39	65.37
2	0.54806	10.20	41.20	32.03	51.40	42.23	56.00	46.00	-4.60	-3.77
3	0.68564	10.23	30.70	21.68	40.93	31.91	56.00	46.00	-15.07	-14.09
4	1.02975	10.29	29.43	19.88	39.72	30.17	56.00	46.00	-16.28	-15.83
5	1.47992	10.33	27.56	20.16	37.89	30.49	56.00	46.00	-18.11	-15.51
6	19.15651	11.36	15.81	8.41	27.17	19.77	60.00	50.00	-32.83	-30.23

Remarks:

1. Q.P. and AV. are abbreviations of quasi-peak and average individually.
2. The emission levels of other frequencies were very low against the limit.
3. Margin value = Emission level - Limit value
4. Correction factor = Insertion loss + Cable loss
5. Emission Level = Correction Factor + Reading Value.

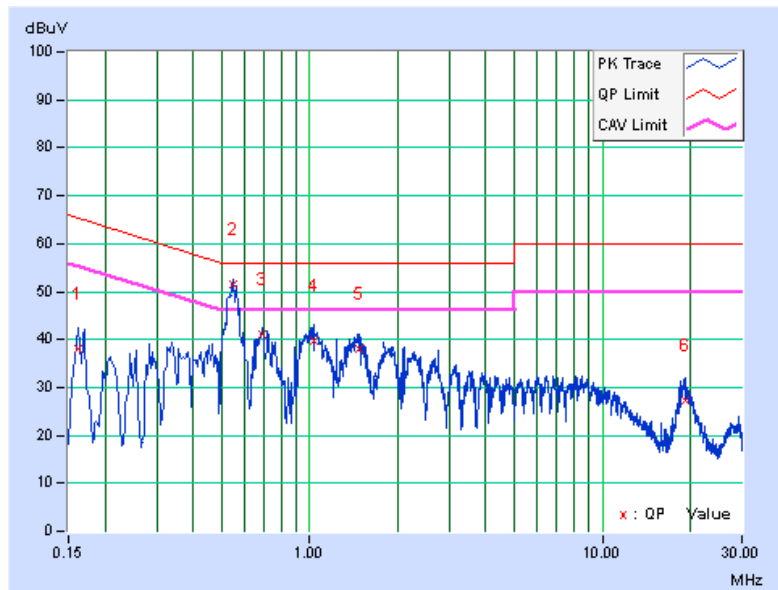

Phase	Neutral (N)	Detector Function	Quasi-Peak (QP) / Average (AV)
-------	-------------	-------------------	--------------------------------

No	Freq. [MHz]	Corr. Factor (dB)	Reading Value [dB (uV)]		Emission Level [dB (uV)]		Limit [dB (uV)]		Margin (dB)	
			Q.P.	AV.	Q.P.	AV.	Q.P.	AV.	Q.P.	AV.
			1	0.16955	10.08	30.81	23.91	40.89	33.99	64.98
2	0.54806	10.25	41.56	32.33	51.81	42.58	56.00	46.00	-4.19	-3.42
3	0.68176	10.26	30.86	22.16	41.12	32.42	56.00	46.00	-14.88	-13.58
4	1.02584	10.29	30.18	21.17	40.47	31.46	56.00	46.00	-15.53	-14.54
5	1.44812	10.33	28.54	20.93	38.87	31.26	56.00	46.00	-17.13	-14.74
6	9.15082	10.81	14.79	7.35	25.60	18.16	60.00	50.00	-34.40	-31.84

Remarks:

1. Q.P. and AV. are abbreviations of quasi-peak and average individually.
2. The emission levels of other frequencies were very low against the limit.
3. Margin value = Emission level - Limit value
4. Correction factor = Insertion loss + Cable loss
5. Emission Level = Correction Factor + Reading Value.

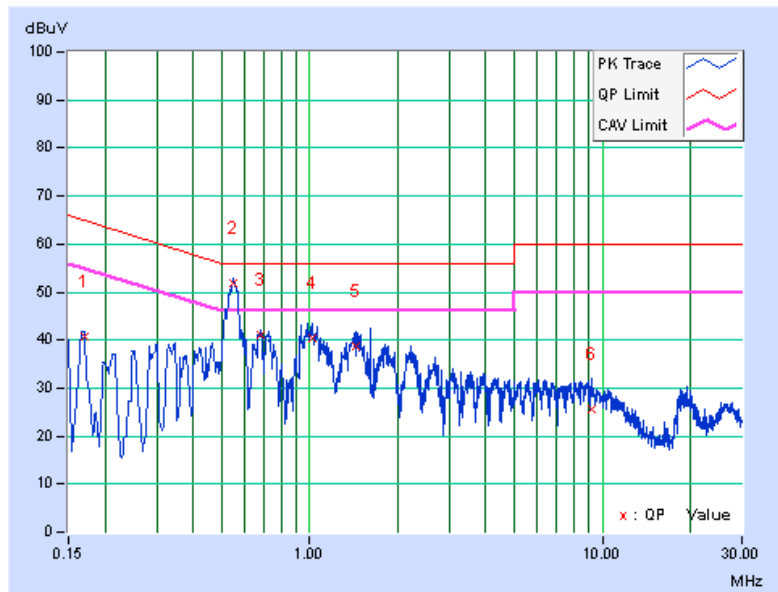

Radio 3: CDD Mode

Phase	Line (L)	Detector Function	Quasi-Peak (QP) / Average (AV)
-------	----------	-------------------	--------------------------------

No	Freq. [MHz]	Corr. Factor (dB)	Reading Value [dB (uV)]		Emission Level [dB (uV)]		Limit [dB (uV)]		Margin (dB)	
			Q.P.	AV.	Q.P.	AV.	Q.P.	AV.	Q.P.	AV.
			1	0.16173	10.08	31.34	23.12	41.42	33.20	65.37
2	0.55273	10.20	42.10	33.15	52.30	43.35	56.00	46.00	-3.70	-2.65
3	0.68958	10.23	31.41	21.12	41.64	31.35	56.00	46.00	-14.36	-14.65
4	0.99065	10.29	29.76	19.39	40.05	29.68	56.00	46.00	-15.95	-16.32
5	1.31518	10.32	25.10	16.40	35.42	26.72	56.00	46.00	-20.58	-19.28
6	18.66776	11.33	15.29	7.15	26.62	18.48	60.00	50.00	-33.38	-31.52

Remarks:

1. Q.P. and AV. are abbreviations of quasi-peak and average individually.
2. The emission levels of other frequencies were very low against the limit.
3. Margin value = Emission level - Limit value
4. Correction factor = Insertion loss + Cable loss
5. Emission Level = Correction Factor + Reading Value.

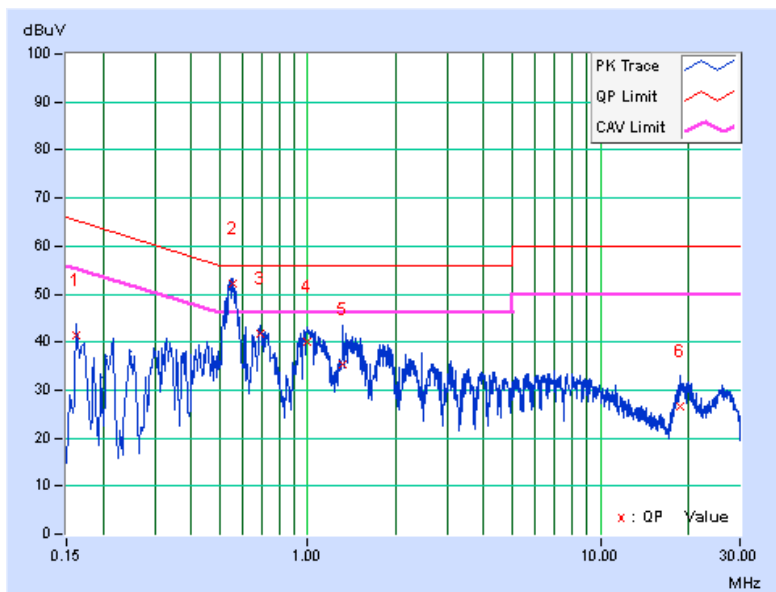

Phase	Neutral (N)	Detector Function	Quasi-Peak (QP) / Average (AV)
-------	-------------	-------------------	--------------------------------

No	Freq. [MHz]	Corr. Factor (dB)	Reading Value [dB (uV)]		Emission Level [dB (uV)]		Limit [dB (uV)]		Margin (dB)	
			Q.P.	AV.	Q.P.	AV.	Q.P.	AV.	Q.P.	AV.
			1	0.16569	10.08	30.38	23.77	40.46	33.85	65.17
2	0.54806	10.25	41.74	32.39	51.99	42.64	56.00	46.00	-4.01	-3.36
3	0.71304	10.27	29.81	19.79	40.08	30.06	56.00	46.00	-15.92	-15.94
4	0.97501	10.29	30.49	22.19	40.78	32.48	56.00	46.00	-15.22	-13.52
5	1.47602	10.34	27.96	20.41	38.30	30.75	56.00	46.00	-17.70	-15.25
6	1.80393	10.37	25.17	18.44	35.54	28.81	56.00	46.00	-20.46	-17.19

Remarks:

1. Q.P. and AV. are abbreviations of quasi-peak and average individually.
2. The emission levels of other frequencies were very low against the limit.
3. Margin value = Emission level - Limit value
4. Correction factor = Insertion loss + Cable loss
5. Emission Level = Correction Factor + Reading Value.

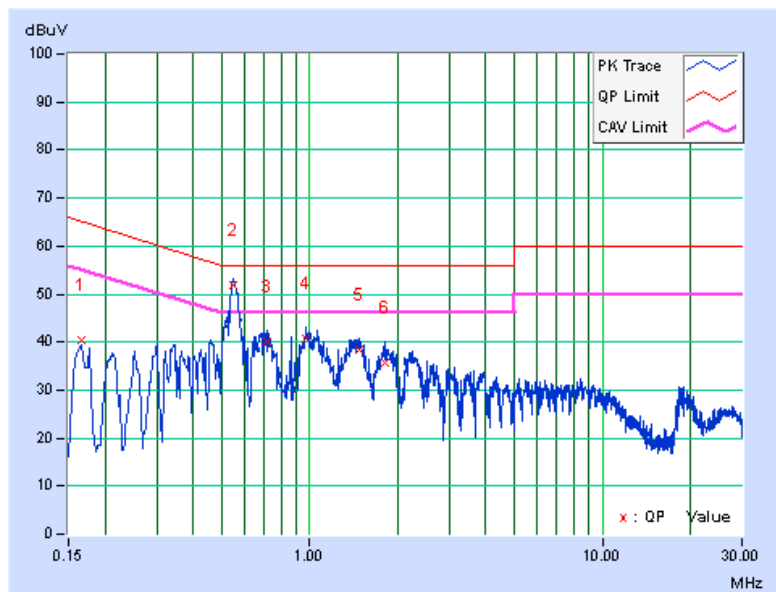

4.3 6dB Bandwidth Measurement

4.3.1 Limits of 6dB Bandwidth Measurement

The minimum of 6dB Bandwidth Measurement is 0.5 MHz.

4.3.2 Test Setup

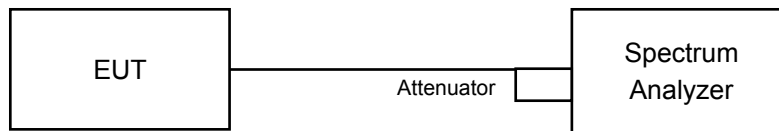

4.3.3 Test Instruments

Refer to section 4.1.2 to get information of above instrument.

4.3.4 Test Procedure

For Radio 1

- Set resolution bandwidth (RBW) = 100kHz
- Set the video bandwidth (VBW) $\geq 3 \times$ RBW, Detector = average.
- Trace mode = max hold.
- Sweep = auto couple.
- Measure the maximum width of the emission that is constrained by the frequencies associated with the two amplitude points (upper and lower) that are attenuated by 6 dB relative to the maximum level measured in the fundamental emission

For Radio 3

- Set resolution bandwidth (RBW) = 100kHz
- Set the video bandwidth (VBW) $\geq 3 \times$ RBW, Detector = peak.
- Trace mode = max hold.
- Sweep = auto couple.
- Measure the maximum width of the emission that is constrained by the frequencies associated with the two amplitude points (upper and lower) that are attenuated by 6 dB relative to the maximum level measured in the fundamental emission

4.3.5 Deviation from Test Standard

No deviation.

4.3.6 EUT Operating Conditions

The software provided by client to enable the EUT under transmission condition continuously at lowest, middle and highest channel frequencies individually.

4.3.7 Test Result

Radio1: CDD Mode

802.11b

Channel	Frequency (MHz)	6dB Bandwidth (MHz)		Minimum Limit (MHz)	Pass / Fail
		Chain 0	Chain 1		
1	2412	8.57	9.05	0.5	Pass
6	2437	9.07	9.07	0.5	Pass
11	2462	9.08	9.06	0.5	Pass

802.11g

Channel	Frequency (MHz)	6dB Bandwidth (MHz)		Minimum Limit (MHz)	Pass / Fail
		Chain 0	Chain 1		
1	2412	16.38	16.39	0.5	Pass
6	2437	16.37	16.39	0.5	Pass
11	2462	16.38	16.39	0.5	Pass

802.11n (HT20)

Channel	Frequency (MHz)	6dB Bandwidth (MHz)		Minimum Limit (MHz)	Pass / Fail
		Chain 0	Chain 1		
1	2412	17.63	17.62	0.5	Pass
6	2437	17.61	17.59	0.5	Pass
11	2462	17.60	17.62	0.5	Pass

802.11n (HT40)

Channel	Frequency (MHz)	6dB Bandwidth (MHz)		Minimum Limit (MHz)	Pass / Fail
		Chain 0	Chain 1		
3	2422	35.32	35.34	0.5	Pass
6	2437	35.26	35.39	0.5	Pass
9	2452	35.26	35.38	0.5	Pass

Spectrum Plot of Worst Value

802.11b

802.11g

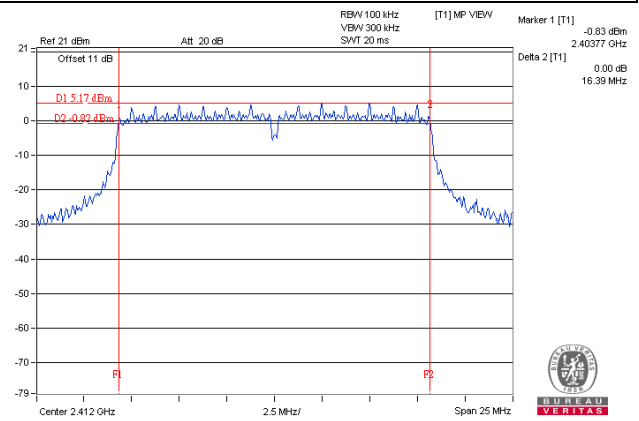
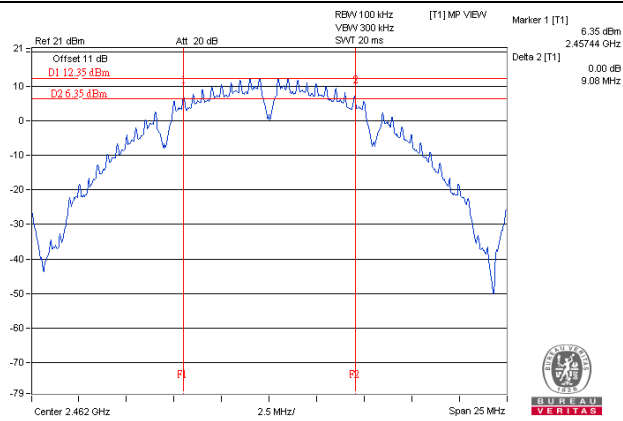

802.11n (HT20)

802.11n (HT40)

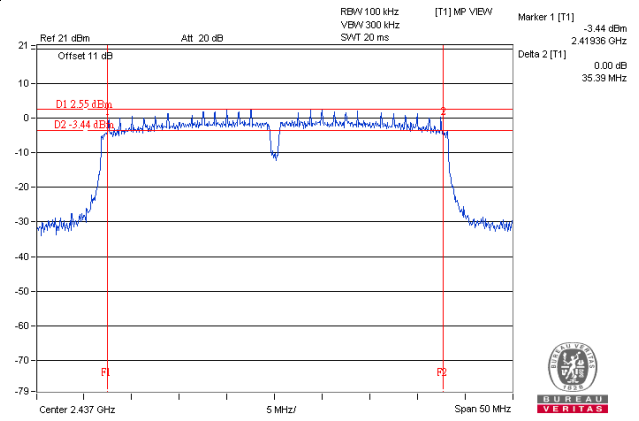
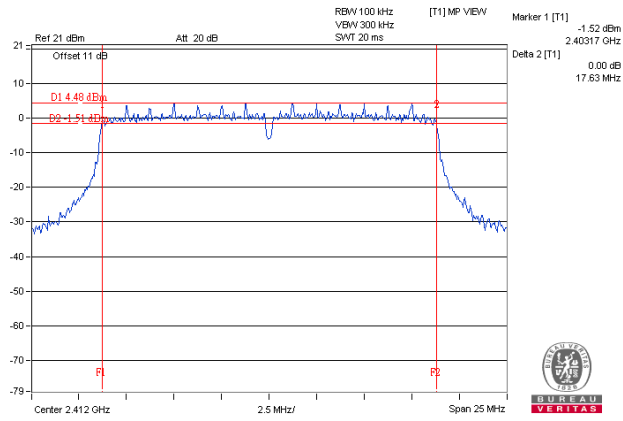

Radio1: Beamforming Mode

802.11n (HT20)

Channel	Frequency (MHz)	6dB Bandwidth (MHz)		Minimum Limit (MHz)	Pass / Fail
		Chain 0	Chain 1		
1	2412	17.60	17.61	0.5	Pass
6	2437	17.59	17.58	0.5	Pass
11	2462	17.58	17.60	0.5	Pass

802.11n (HT40)

Channel	Frequency (MHz)	6dB Bandwidth (MHz)		Minimum Limit (MHz)	Pass / Fail
		Chain 0	Chain 1		
3	2422	35.22	35.25	0.5	Pass
6	2437	35.23	35.23	0.5	Pass
9	2452	35.22	35.25	0.5	Pass

Spectrum Plot of Worst Value

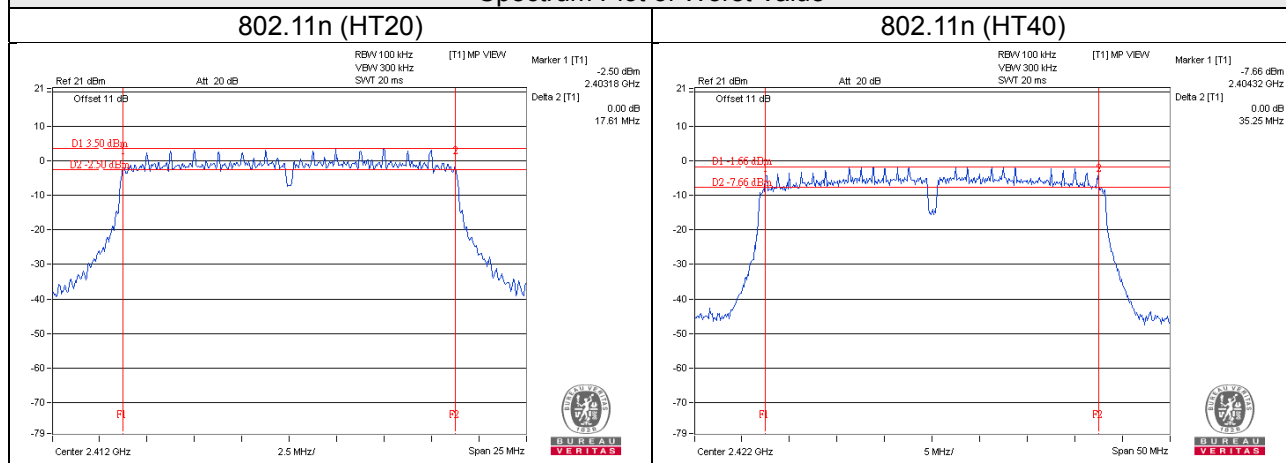

Radio3: CDD Mode

802.11b

Channel	Frequency (MHz)	6dB Bandwidth (MHz)	Minimum Limit (MHz)	Pass / Fail
1	2412	7.09	0.5	Pass
6	2437	7.07	0.5	Pass
11	2462	7.07	0.5	Pass

802.11g

Channel	Frequency (MHz)	6dB Bandwidth (MHz)	Minimum Limit (MHz)	Pass / Fail
1	2412	16.36	0.5	Pass
6	2437	16.36	0.5	Pass
11	2462	16.37	0.5	Pass

802.11n (HT20)

Channel	Frequency (MHz)	6dB Bandwidth (MHz)	Minimum Limit (MHz)	Pass / Fail
1	2412	17.32	0.5	Pass
6	2437	17.30	0.5	Pass
11	2462	16.93	0.5	Pass

802.11n (HT40)

Channel	Frequency (MHz)	6dB Bandwidth (MHz)	Minimum Limit (MHz)	Pass / Fail
3	2422	35.79	0.5	Pass
6	2437	35.75	0.5	Pass
9	2452	35.86	0.5	Pass

Spectrum Plot of Worst Value

802.11b

802.11g

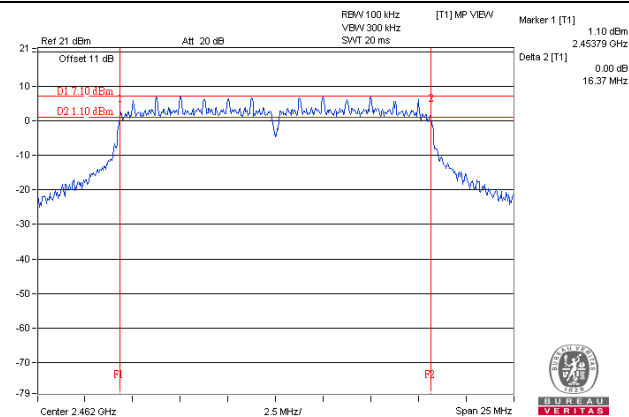
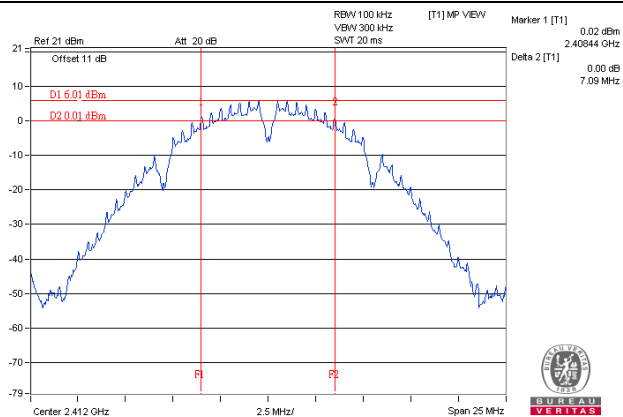

802.11n (HT20)

802.11n (HT40)

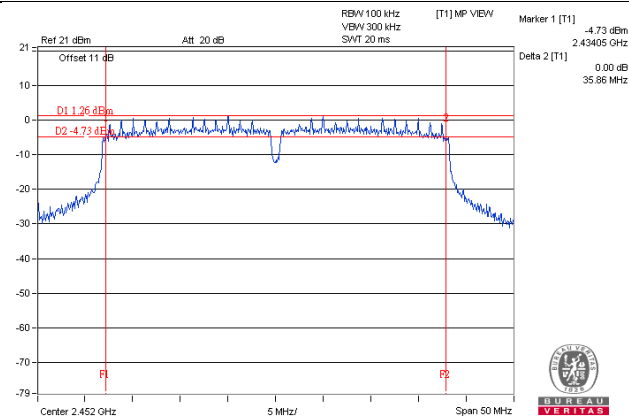
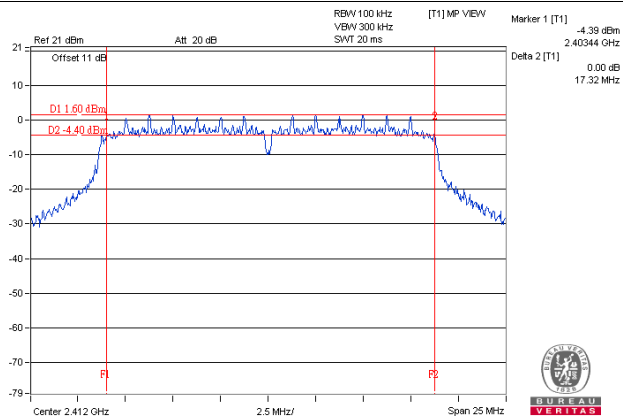

4.4 Conducted Output Power Measurement

4.4.1 Limits of Conducted Output Power Measurement

For systems using digital modulation in the 2400–2483.5 MHz bands: 1 Watt (30dBm)

Per KDB 662911 D01 Multiple Transmitter Output Method of conducted output power measurement on IEEE 802.11 devices,

Array Gain = 0 dB (i.e., no array gain) for $NANT \leq 4$;

Array Gain = 0 dB (i.e., no array gain) for channel widths ≥ 40 MHz for any NANT;

Array Gain = $5 \log(NANT/NSS)$ dB or 3 dB, whichever is less for 20-MHz channel widths with $NANT \geq 5$.

For power measurements on all other devices: Array Gain = $10 \log(NANT/NSS)$ dB.

4.4.2 Test Setup

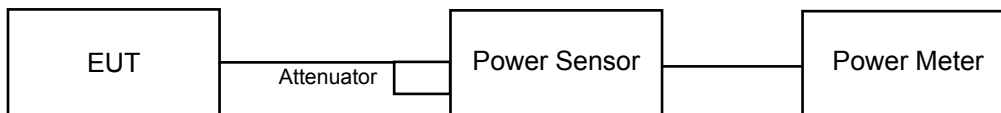

4.4.3 Test Instruments

Refer to section 4.1.2 to get information of above instrument.

4.4.4 Test Procedures

For Radio 1

An average power sensor was used on the output port of the EUT. A power meter was used to read the response of the average power sensor. Record the power level.

For Radio 3

A peak power sensor was used on the output port of the EUT. A power meter was used to read the response of the peak power sensor. Record the power level.

An average power sensor was used on the output port of the EUT. A power meter was used to read the response of the average power sensor. Record the power level.

4.4.5 Deviation from Test Standard

No deviation.

4.4.6 EUT Operating Conditions

Same as Item 4.3.6.

4.4.7 Test Results

Radio 1: CDD Mode

802.11b

Channel	Frequency (MHz)	Average Power (dBm)		Total Power (mW)	Total Power (dBm)	Limit (dBm)	Pass / Fail
		Chain 0	Chain 1				
1	2412	21.04	20.34	235.200	23.71	30	Pass
6	2437	20.82	20.14	224.057	23.50	30	Pass
11	2462	20.59	20.23	219.990	23.42	30	Pass

802.11g

Channel	Frequency (MHz)	Average Power (dBm)		Total Power (mW)	Total Power (dBm)	Limit (dBm)	Pass / Fail
		Chain 0	Chain 1				
1	2412	16.47	16.02	84.355	19.26	30	Pass
6	2437	20.25	19.65	198.182	22.97	30	Pass
11	2462	15.84	15.75	75.955	18.81	30	Pass

802.11n (HT20)

Channel	Frequency (MHz)	Average Power (dBm)		Total Power (mW)	Total Power (dBm)	Limit (dBm)	Pass / Fail
		Chain 0	Chain 1				
1	2412	15.80	15.64	74.663	18.73	30	Pass
6	2437	20.17	19.70	197.317	22.95	30	Pass
11	2462	15.44	15.37	69.430	18.42	30	Pass

802.11n (HT40)

Channel	Frequency (MHz)	Average Power (dBm)		Total Power (mW)	Total Power (dBm)	Limit (dBm)	Pass / Fail
		Chain 0	Chain 1				
3	2422	15.06	14.81	62.332	17.95	30	Pass
6	2437	16.64	16.18	87.627	19.43	30	Pass
9	2452	15.23	15.15	66.077	18.20	30	Pass

Radio 1: Beamforming Mode

802.11n (HT20)

Channel	Frequency (MHz)	Average Power (dBm)		Total Power (mW)	Total Power (dBm)	Limit (dBm)	Pass / Fail
		Chain 0	Chain 1				
1	2412	15.04	14.83	62.324	17.95	29.28	Pass
6	2437	19.67	19.18	175.477	22.44	29.28	Pass
11	2462	15.64	15.40	71.318	18.53	29.28	Pass

Note: Directional gain = $10 \log[(10^{G1/20} + 10^{G2/20} + \dots + 10^{GN/20})^2/2] = 6.72\text{dBi} > 6\text{dBi}$, so the power limit shall be reduced to $30 - (6.72 - 6) = 29.28\text{dBm}$.

802.11n (HT40)

Channel	Frequency (MHz)	Average Power (dBm)		Total Power (mW)	Total Power (dBm)	Limit (dBm)	Pass / Fail
		Chain 0	Chain 1				
3	2422	12.86	12.61	37.559	15.75	29.28	Pass
6	2437	16.27	15.74	79.861	19.02	29.28	Pass
9	2452	12.82	12.63	37.466	15.74	29.28	Pass

Note: Directional gain = $10 \log[(10^{G1/20} + 10^{G2/20} + \dots + 10^{GN/20})^2/2] = 6.72\text{dBi} > 6\text{dBi}$, so the power limit shall be reduced to $30 - (6.72 - 6) = 29.28\text{dBm}$.

Radio 3: CDD Mode

Peak Power

802.11b

Channel	Frequency (MHz)	Peak Power (mW)	Peak Power (dBm)	Limit (dBm)	Pass / Fail
1	2412	46.989	16.72	30	Pass
6	2437	28.576	14.56	30	Pass
11	2462	26.485	14.23	30	Pass

802.11g

Channel	Frequency (MHz)	Peak Power (mW)	Peak Power (dBm)	Limit (dBm)	Pass / Fail
1	2412	45.290	16.56	30	Pass
6	2437	238.781	23.78	30	Pass
11	2462	142.889	21.55	30	Pass

802.11n (HT20)

Channel	Frequency (MHz)	Peak Power (mW)	Peak Power (dBm)	Limit (dBm)	Pass / Fail
1	2412	47.643	16.78	30	Pass
6	2437	246.037	23.91	30	Pass
11	2462	129.420	21.12	30	Pass

802.11n (HT40)

Channel	Frequency (MHz)	Peak Power (mW)	Peak Power (dBm)	Limit (dBm)	Pass / Fail
3	2422	52.966	17.24	30	Pass
6	2437	146.555	21.66	30	Pass
9	2452	80.91	19.08	30	Pass

Average Power

802.11b

Channel	Frequency (MHz)	Average Power (mW)	Average Power (dBm)
1	2412	23.335	13.68
6	2437	14.322	11.56
11	2462	13.183	11.20

802.11g

Channel	Frequency (MHz)	Average Power (mW)	Average Power (dBm)
1	2412	16.106	12.07
6	2437	119.950	20.79
11	2462	55.463	17.44

802.11n (HT20)

Channel	Frequency (MHz)	Average Power (mW)	Average Power (dBm)
1	2412	16.032	12.05
6	2437	116.413	20.66
11	2462	47.098	16.73

802.11n (HT40)

Channel	Frequency (MHz)	Average Power (mW)	Average Power (dBm)
3	2422	17.620	12.46
6	2437	57.280	17.58
9	2452	30.269	14.81

4.5 Power Spectral Density Measurement

4.5.1 Limits of Power Spectral Density Measurement

The Maximum of Power Spectral Density Measurement is 8dBm.

4.5.2 Test Setup

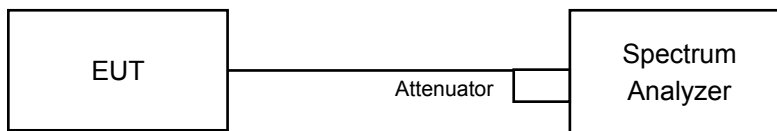

4.5.3 Test Instruments

Refer to section 4.1.2 to get information of above instrument.

4.5.4 Test Procedure

For Radio 1 (duty cycle $\geq 98\%$)

- Set instrument center frequency to DTS channel center frequency.
- Set span to at least 1.5 times the OBW.
- Set RBW to: $3 \text{ kHz} \leq \text{RBW} \leq 100 \text{ kHz}$.
- Set VBW $\geq 3 \times \text{RBW}$.
- Detector = power averaging (RMS) or sample detector (when RMS not available).
- Ensure that the number of measurement points in the sweep $\geq 2 \times \text{span}/\text{RBW}$.
- Sweep time = auto couple.
- Employ trace averaging (RMS) mode over a minimum of 100 traces.
- Use the peak marker function to determine the maximum amplitude level.

For Radio 1 (duty cycle $< 98\%$)

- Measure the duty cycle (x).
- Set instrument center frequency to DTS channel center frequency.
- Set span to at least 1.5 times the OBW.
- Set RBW to: $3 \text{ kHz} \leq \text{RBW} \leq 100 \text{ kHz}$.
- Set VBW $\geq 3 \times \text{RBW}$.
- Detector = power averaging (RMS) or sample detector (when RMS not available).
- Ensure that the number of measurement points in the sweep $\geq 2 \times \text{span}/\text{RBW}$.
- Sweep time = auto couple.
- Do not use sweep triggering. Allow sweep to "free run".
- Employ trace averaging (RMS) mode over a minimum of 100 traces.
- Use the peak marker function to determine the maximum amplitude level.
- Add $10 \log (1/x)$, where x is the duty cycle measured in step (a), to the measured PSD to compute the average PSD during the actual transmission time.

For Radio 3

- a. Set analyzer center frequency to DTS channel center frequency.
- b. Set the span to 1.5 times the DTS bandwidth.
- c. Set the RBW to: $3 \text{ kHz} \leq \text{RBW} \leq 100 \text{ kHz}$.
- d. Set the VBW $\geq 3 \times \text{RBW}$.
- e. Detector = peak.
- f. Sweep time = auto couple.
- g. Trace mode = max hold.
- h. Allow trace to fully stabilize.
- i. Use the peak marker function to determine the maximum amplitude level within the RBW.

4.5.5 Deviation from Test Standard

No deviation.

4.5.6 EUT Operating Condition

Same as Item 4.3.6

4.5.7 Test Results

Radio 1: CDD Mode

802.11b

TX chain	Channel	Frequency (MHz)	PSD (dBm)	10 log (N=2) dB	Total PSD (dBm)	Limit (dBm)	Pass / Fail
0	1	2412	-6.85	3.01	-3.84	7.28	Pass
	6	2437	-7.33	3.01	-4.32	7.28	Pass
	11	2462	-7.30	3.01	-4.29	7.28	Pass
1	1	2412	-7.69	3.01	-4.68	7.28	Pass
	6	2437	-7.21	3.01	-4.20	7.28	Pass
	11	2462	-7.01	3.01	-4.00	7.28	Pass

Note:

- Method 1 of power density measurement of KDB 662911 is using for calculating total power density. Total power density is summing entire spectra across corresponding frequency bins on the various outputs by computer.
- Directional gain = $10 \log[(10^{G1/20} + 10^{G2/20} + \dots + 10^{GN/20})^2/2] = 6.72\text{dBi} > 6\text{dBi}$, so the power density limit shall be reduced to $8 - (6.72 - 6) = 7.28\text{dBm}$

802.11g

TX chain	Channel	Frequency (MHz)	PSD (dBm)	10 log (N=2) dB	Duty Factor	Total PSD with Duty Factor (dBm)	Limit (dBm)	Pass / Fail
0	1	2412	-14.38	3.01	0.21	-11.16	7.28	Pass
	6	2437	-10.51	3.01	0.21	-7.29	7.28	Pass
	11	2462	-14.45	3.01	0.21	-11.23	7.28	Pass
1	1	2412	-14.68	3.01	0.21	-11.46	7.28	Pass
	6	2437	-10.75	3.01	0.21	-7.53	7.28	Pass
	11	2462	-14.69	3.01	0.21	-11.47	7.28	Pass

Note:

- Method 1 of power density measurement of KDB 662911 is using for calculating total power density. Total power density is summing entire spectra across corresponding frequency bins on the various outputs by computer.
- Directional gain = $10 \log[(10^{G1/20} + 10^{G2/20} + \dots + 10^{GN/20})^2/2] = 6.72\text{dBi} > 6\text{dBi}$, so the power density limit shall be reduced to $8 - (6.72 - 6) = 7.28\text{dBm}$
- Refer to section 3.3 for duty cycle spectrum plot.

802.11n (HT20)

TX chain	Channel	Frequency (MHz)	PSD (dBm)	10 log (N=2) dB	Total PSD (dBm)	Limit (dBm)	Pass / Fail
0	1	2412	-15.30	3.01	-12.29	7.28	Pass
	6	2437	-11.07	3.01	-8.06	7.28	Pass
	11	2462	-15.68	3.01	-12.67	7.28	Pass
1	1	2412	-15.77	3.01	-12.76	7.28	Pass
	6	2437	-11.49	3.01	-8.48	7.28	Pass
	11	2462	-15.70	3.01	-12.69	7.28	Pass

Note:

- Method 1 of power density measurement of KDB 662911 is using for calculating total power density. Total power density is summing entire spectra across corresponding frequency bins on the various outputs by computer.
- Directional gain = $10 \log[(10^{G1/20} + 10^{G2/20} + \dots + 10^{GN/20})^2/2] = 6.72\text{dBi} > 6\text{dBi}$, so the power density limit shall be reduced to $8 - (6.72 - 6) = 7.28\text{dBm}$

802.11n (HT40)

TX chain	Channel	Frequency (MHz)	PSD (dBm)	10 log (N=2) dB	Duty Factor	Total PSD with Duty Factor (dBm)	Limit (dBm)	Pass / Fail
0	3	2422	-18.67	3.01	0.18	-15.48	7.28	Pass
	6	2437	-16.80	3.01	0.18	-13.61	7.28	Pass
	9	2452	-18.33	3.01	0.18	-15.14	7.28	Pass
1	3	2422	-18.70	3.01	0.18	-15.51	7.28	Pass
	6	2437	-17.36	3.01	0.18	-14.17	7.28	Pass
	9	2452	-18.57	3.01	0.18	-15.38	7.28	Pass

Note:

- Method 1 of power density measurement of KDB 662911 is using for calculating total power density. Total power density is summing entire spectra across corresponding frequency bins on the various outputs by computer.
- Directional gain = $10 \log[(10^{G1/20} + 10^{G2/20} + \dots + 10^{GN/20})^2/2] = 6.72\text{dBi} > 6\text{dBi}$, so the power density limit shall be reduced to $8 - (6.72 - 6) = 7.28\text{dBm}$
- Refer to section 3.3 for duty cycle spectrum plot.

Spectrum Plot of Worst Value

802.11b

802.11g

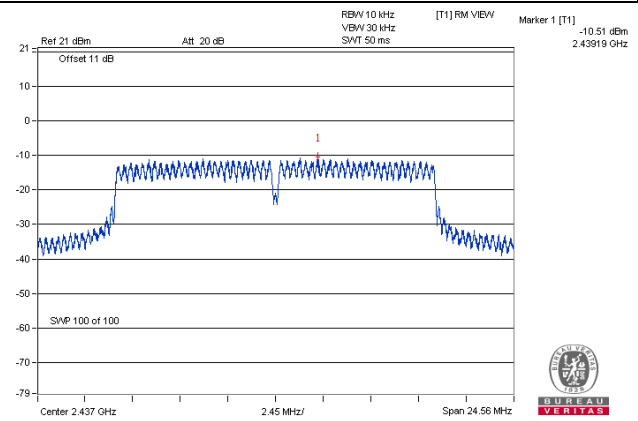
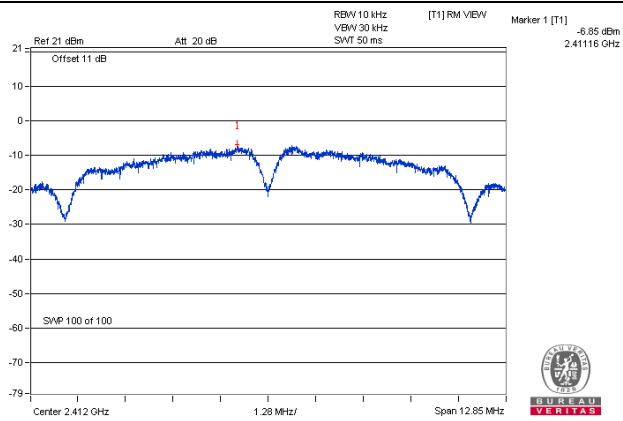

802.11n (HT20)

802.11n (HT40)

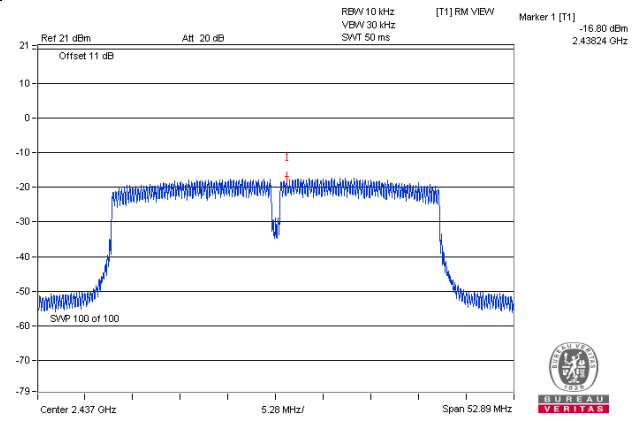
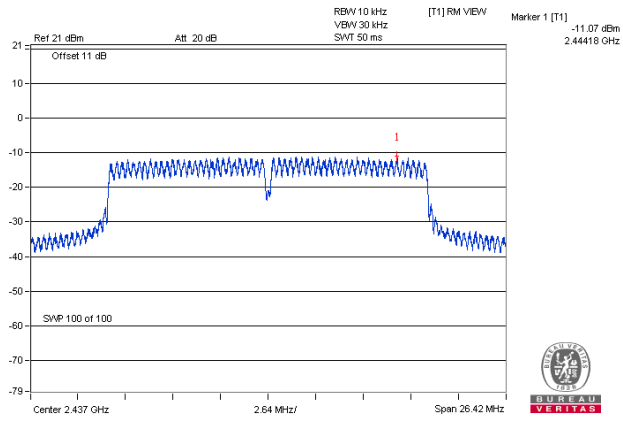

Radio 1: Beamforming Mode

802.11n (HT20)

TX chain	Channel	Frequency (MHz)	PSD (dBm)	10 log (N=2) dB	Total PSD (dBm)	Limit (dBm)	Pass / Fail
0	1	2412	-15.90	3.01	-12.89	7.28	Pass
	6	2437	-11.13	3.01	-8.12	7.28	Pass
	11	2462	-15.23	3.01	-12.22	7.28	Pass
1	1	2412	-16.33	3.01	-13.32	7.28	Pass
	6	2437	-11.94	3.01	-8.93	7.28	Pass
	11	2462	-15.35	3.01	-12.34	7.28	Pass

Note:

- Method 1 of power density measurement of KDB 662911 is using for calculating total power density. Total power density is summing entire spectra across corresponding frequency bins on the various outputs by computer.
- Directional gain = $10 \log[(10^{G1/20} + 10^{G2/20} + \dots + 10^{GN/20})^2/2] = 6.72\text{dBi} > 6\text{dBi}$, so the power density limit shall be reduced to $8 - (6.72 - 6) = 7.28\text{dBm}$

802.11n (HT40)

TX chain	Channel	Frequency (MHz)	PSD (dBm)	10 log (N=2) dB	Duty Factor	Total PSD with Duty Factor (dBm)	Limit (dBm)	Pass / Fail
0	3	2422	-21.52	3.01	0.18	-18.33	7.28	Pass
	6	2437	-17.71	3.01	0.18	-14.52	7.28	Pass
	9	2452	-21.26	3.01	0.18	-18.07	7.28	Pass
1	3	2422	-21.82	3.01	0.18	-18.63	7.28	Pass
	6	2437	-18.52	3.01	0.18	-15.33	7.28	Pass
	9	2452	-21.32	3.01	0.18	-18.13	7.28	Pass

Note:

- Method 1 of power density measurement of KDB 662911 is using for calculating total power density. Total power density is summing entire spectra across corresponding frequency bins on the various outputs by computer.
- Directional gain = $10 \log[(10^{G1/20} + 10^{G2/20} + \dots + 10^{GN/20})^2/2] = 6.72\text{dBi} > 6\text{dBi}$, so the power density limit shall be reduced to $8 - (6.72 - 6) = 7.28\text{dBm}$
- Refer to section 3.3 for duty cycle spectrum plot.

Spectrum Plot of Worst Value

802.11n (HT20)

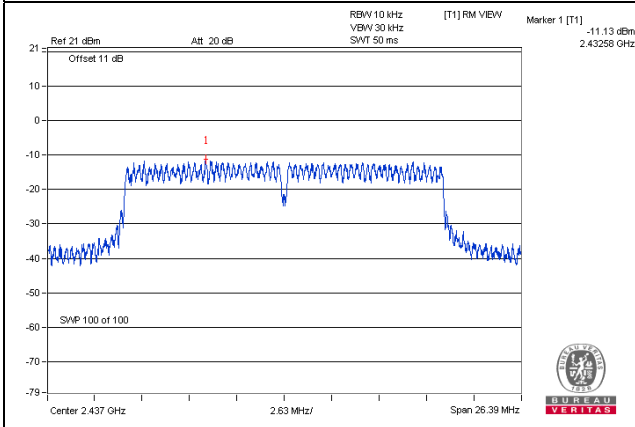

802.11n (HT40)

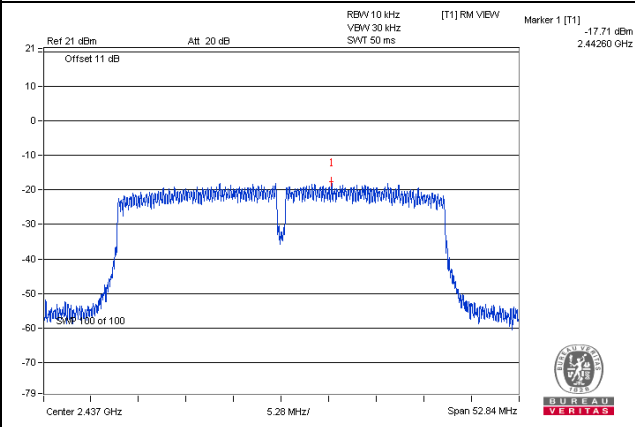

Radio 3: CDD Mode

802.11b

Channel	Frequency (MHz)	PSD (dBm)	Limit (dBm)	Pass / Fail
1	2412	-8.51	8.00	Pass
6	2437	-9.77	8.00	Pass
11	2462	-10.74	8.00	Pass

802.11g

Channel	Frequency (MHz)	PSD (dBm)	Limit (dBm)	Pass / Fail
1	2412	-14.27	8.00	Pass
6	2437	-4.82	8.00	Pass
11	2462	-8.23	8.00	Pass

802.11n (HT20)

Channel	Frequency (MHz)	PSD (dBm)	Limit (dBm)	Pass / Fail
1	2412	-13.48	8.00	Pass
6	2437	-4.84	8.00	Pass
11	2462	-9.59	8.00	Pass

802.11n (HT40)

Channel	Frequency (MHz)	PSD (dBm)	Limit (dBm)	Pass / Fail
3	2422	-16.26	8.00	Pass
6	2437	-11.38	8.00	Pass
9	2452	-14.22	8.00	Pass

Spectrum Plot of Worst Value

802.11b

802.11g

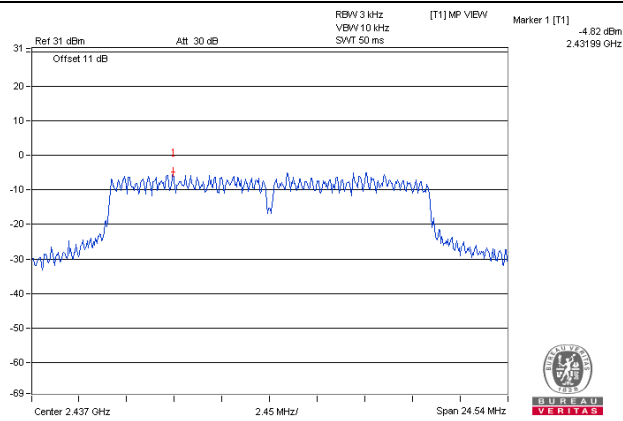
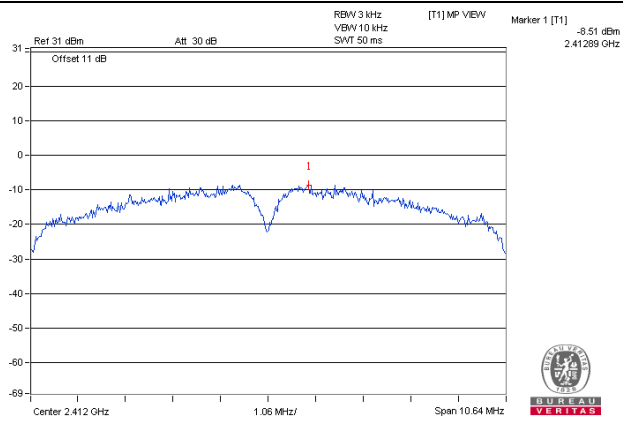

802.11n (HT20)

802.11n (HT40)

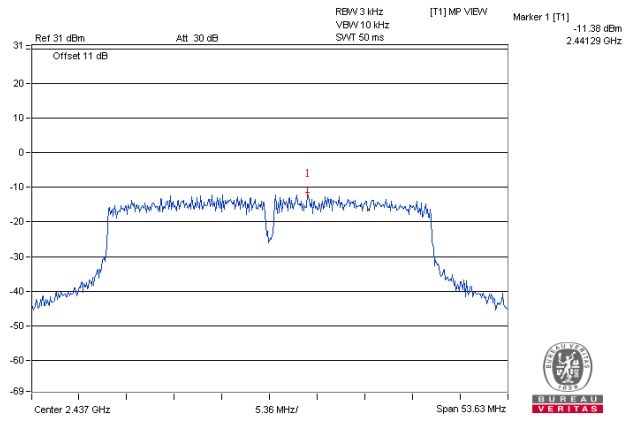
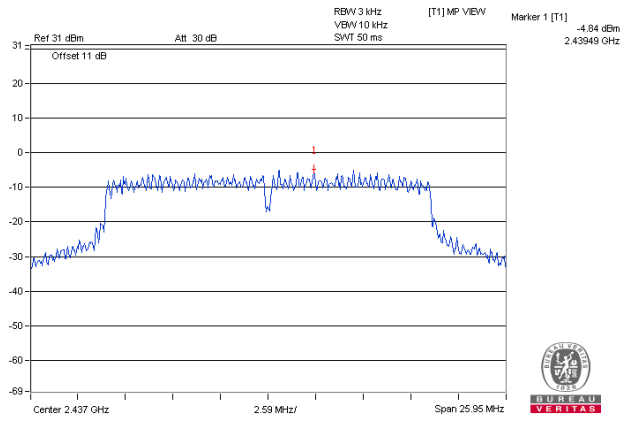

4.6 Conducted Out of Band Emission Measurement

4.6.1 Limits of Conducted Out of Band Emission Measurement

Below 20dB / 30dB of the highest emission level of operating band (in 100kHz Resolution Bandwidth).

4.6.2 Test Setup

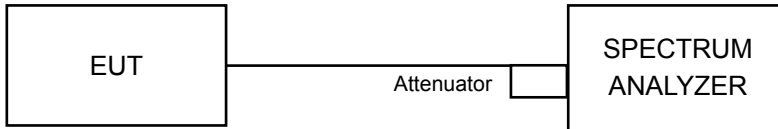

4.6.3 Test Instruments

Refer to section 4.1.2 to get information of above instrument.

4.6.4 Test Procedure

For Radio 1

MEASUREMENT PROCEDURE REF

- Set the RBW = 100 kHz.
- Set the VBW \geq 300 kHz.
- Detector = average.
- Sweep time = auto couple.
- Trace mode = max hold.
- Allow trace to fully stabilize.
- Use the peak marker function to determine the maximum power level in any 100 kHz band segment within the fundamental EBW.

MEASUREMENT PROCEDURE OOBE

- Set RBW = 100 kHz.
- Set VBW \geq 300 kHz.
- Ensure that the number of measurement points \geq span/RBW
- According to measurement points to set differ measurement span.
- Detector = average.
- Trace Mode = max hold.
- Sweep = auto couple.

For Radio 3

MEASUREMENT PROCEDURE REF

- a. Set the RBW = 100 kHz.
- b. Set the VBW \geq 300 kHz.
- c. Detector = peak.
- d. Sweep time = auto couple.
- e. Trace mode = max hold.
- f. Allow trace to fully stabilize.
- g. Use the peak marker function to determine the maximum power level in any 100 kHz band segment within the fundamental EBW.

MEASUREMENT PROCEDURE OOB

- a. Set RBW = 100 kHz.
- b. Set VBW \geq 300 kHz.
- c. Ensure that the number of measurement points \geq span/RBW
- d. According to measurement points to set differ measurement span.
- e. Detector = peak.
- f. Trace Mode = max hold.
- g. Sweep = auto couple.

4.6.5 Deviation from Test Standard

No deviation.

4.6.6 EUT Operating Condition

Same as Item 4.3.6

4.6.7 Test Results

The spectrum plots are attached on the following pages. D1 line indicates the highest level, and D2 line indicates the 20dB / 30dB offset below D1. It shows compliance with the requirement.

Radio 1: CDD Mode
802.11b_Chain 0

CH 1

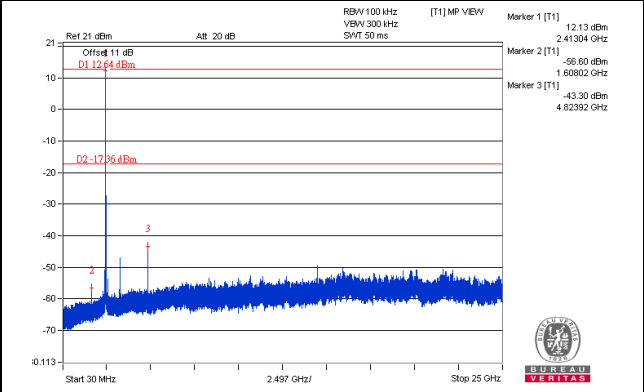
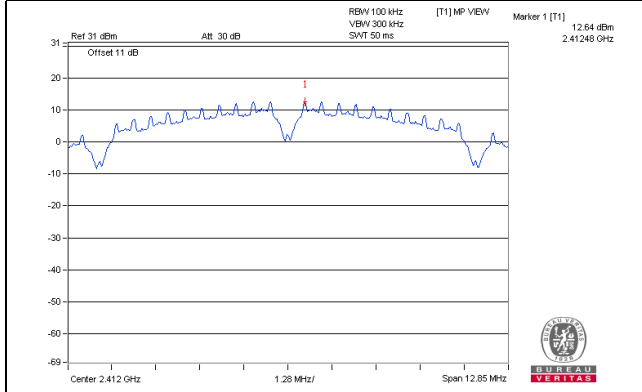

CH 6

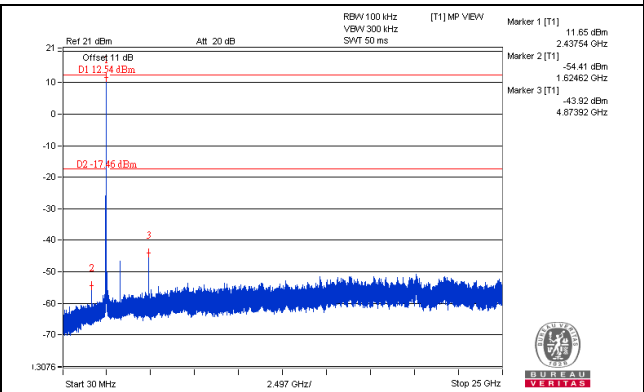
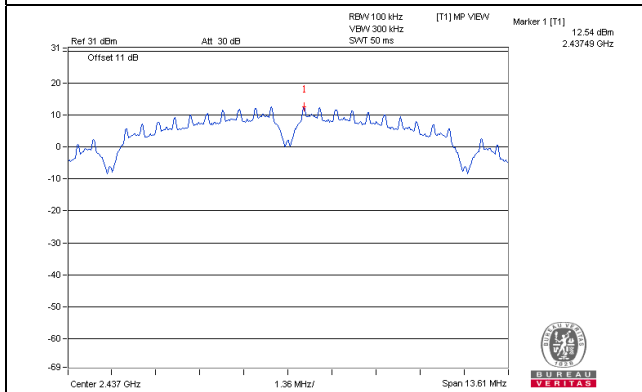

CH 11

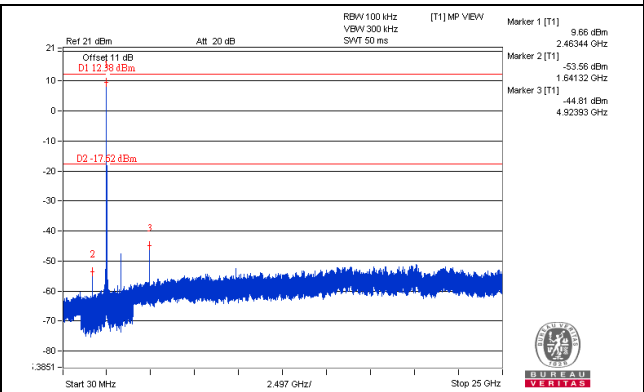
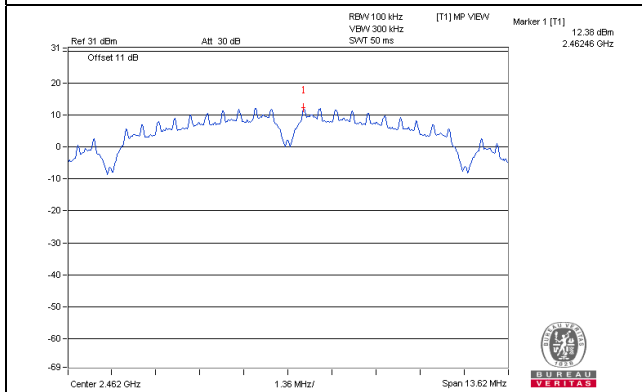

CH 1 Band edge

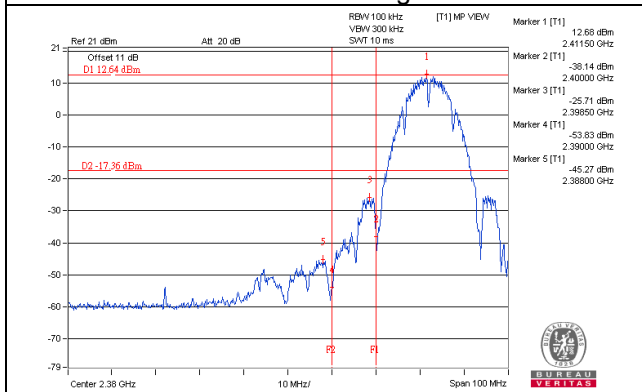

CH 11 Band edge

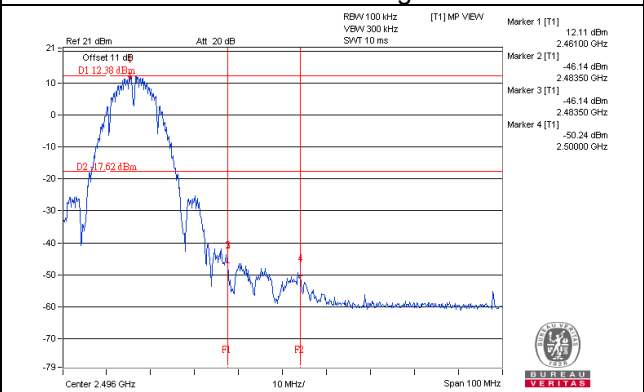

802.11b_Chain 1

CH 1

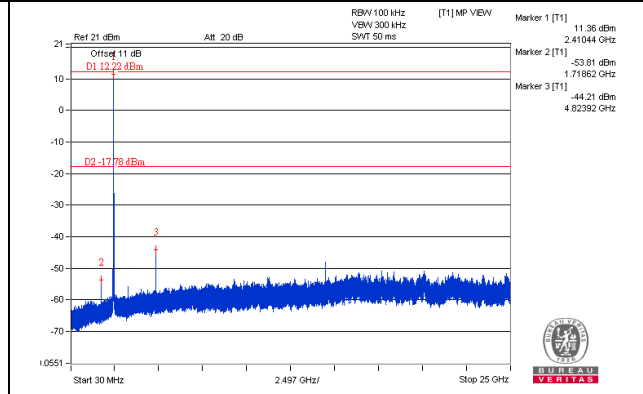
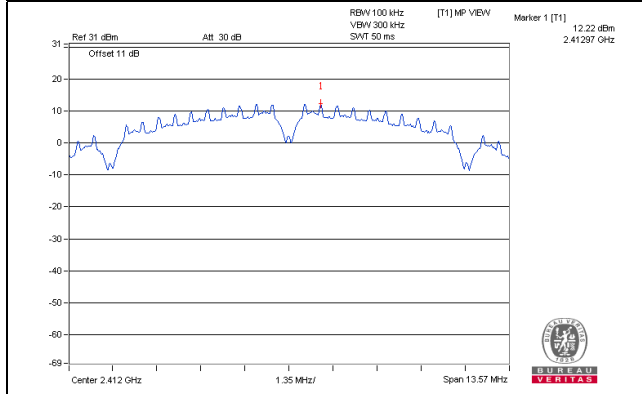

CH 6

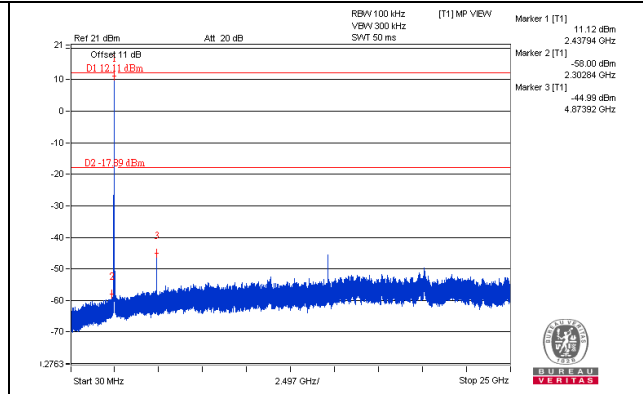
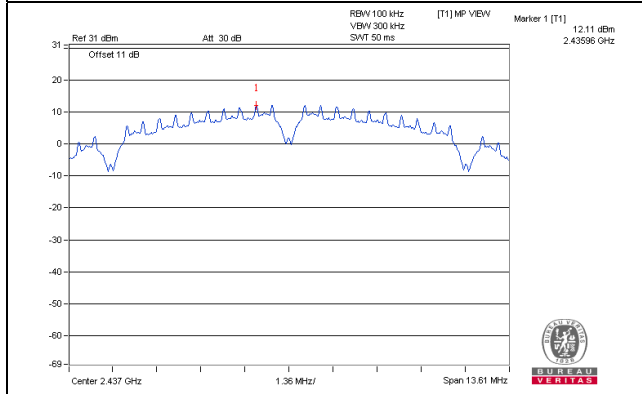

CH 11

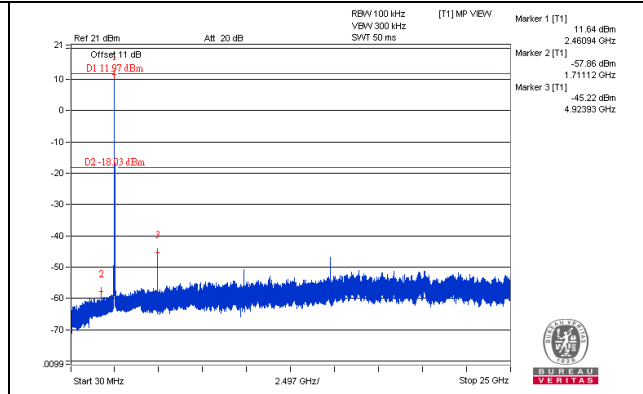
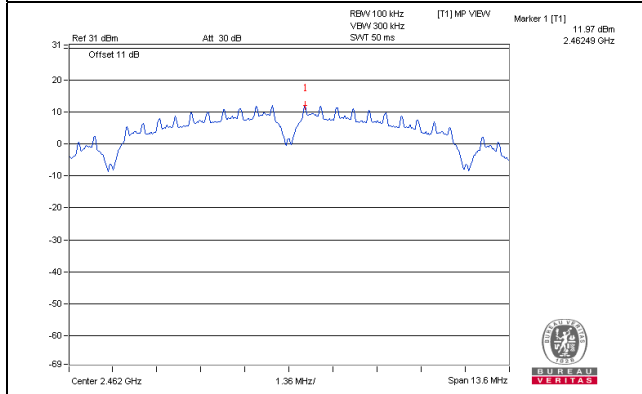

CH 1 Band edge

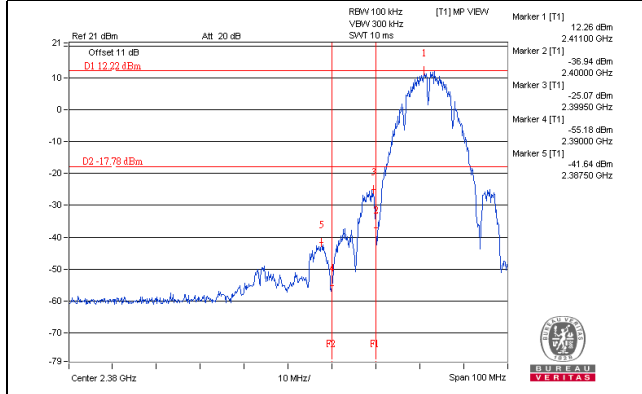

CH 11 Band edge

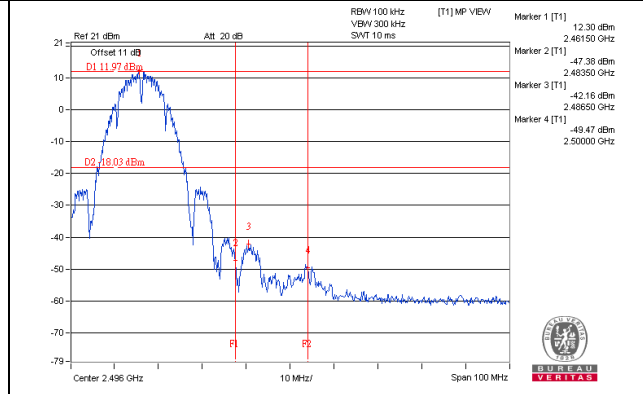

802.11g_Chain 0

CH 1

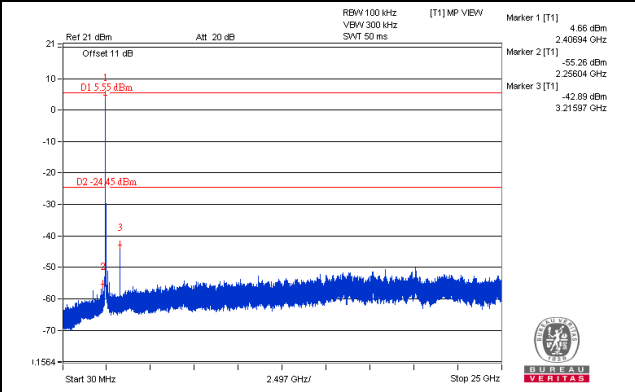
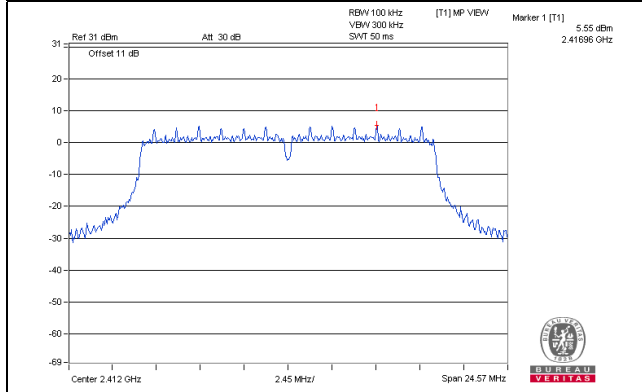

CH 6

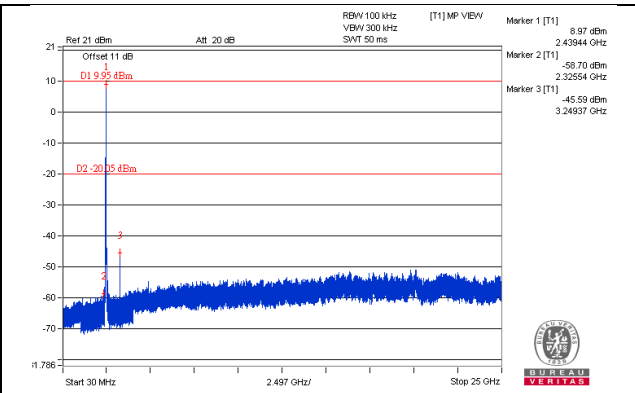
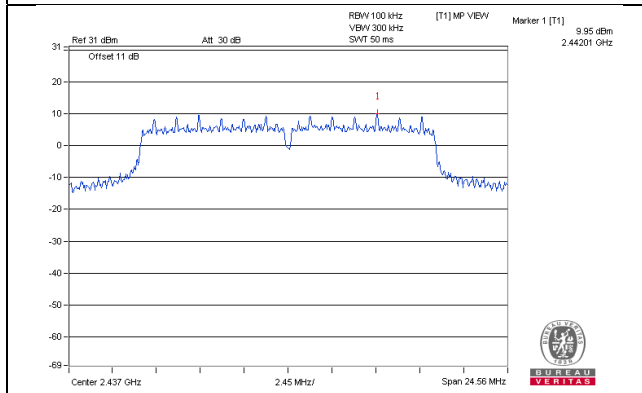

CH 11

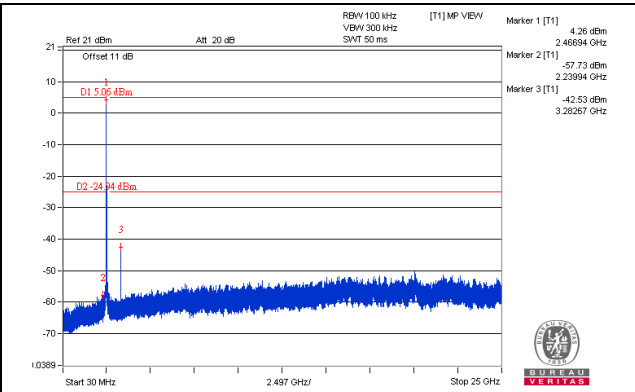
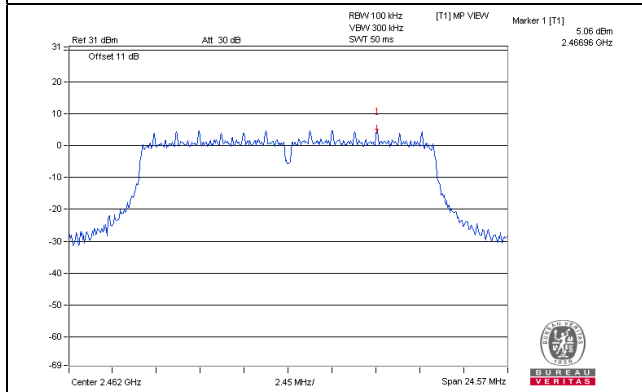

CH 1 Band edge

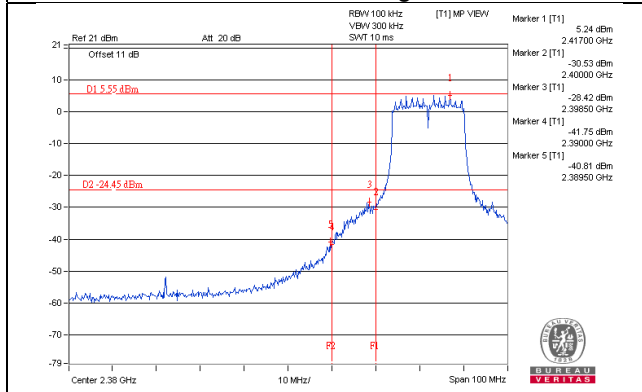

CH 11 Band edge

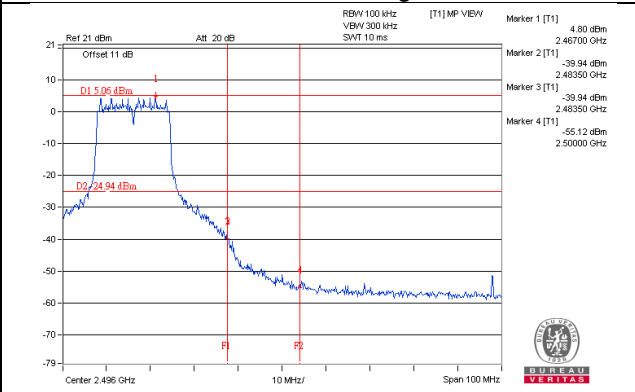

802.11g_Chain 1

CH 1

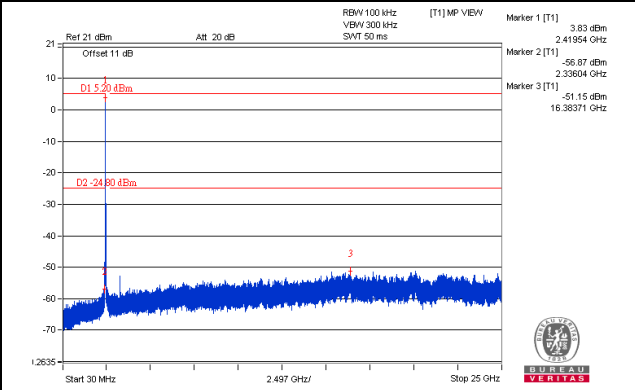
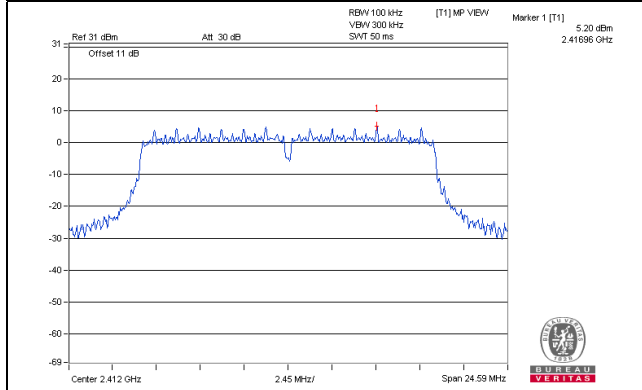

CH 6

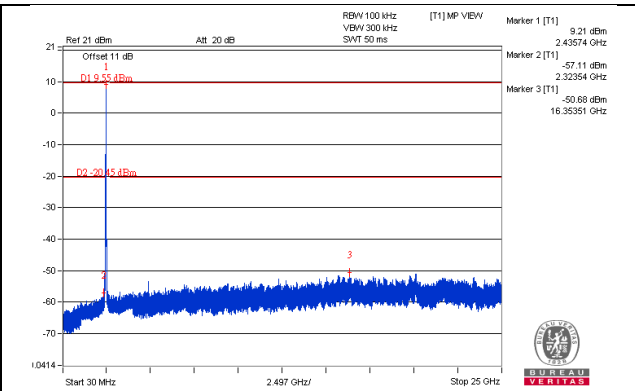
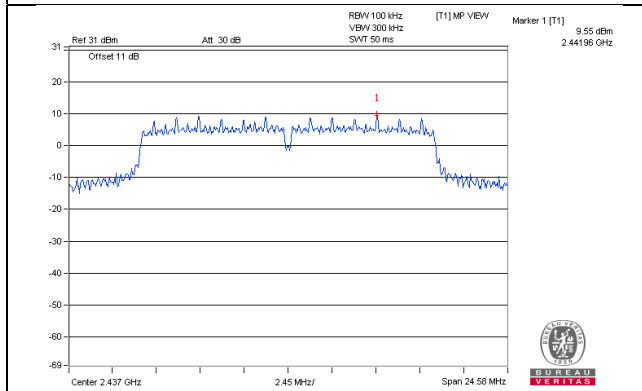

CH 11

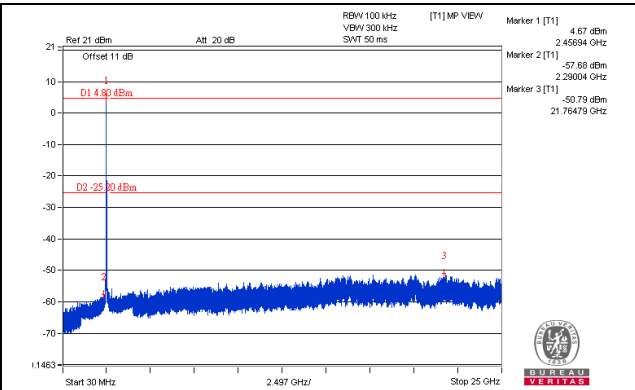
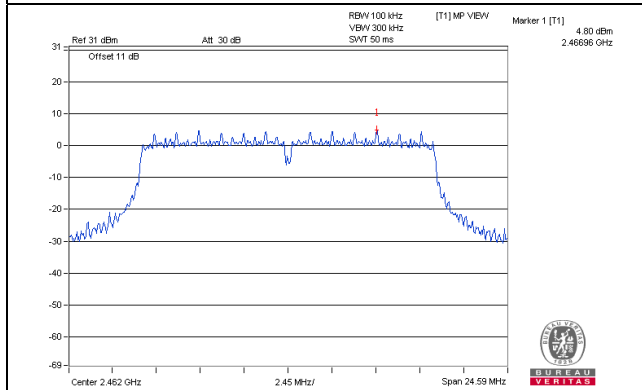

CH 1 Band edge

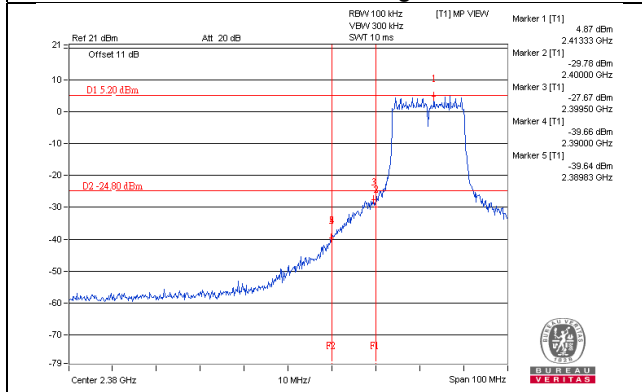

CH 11 Band edge

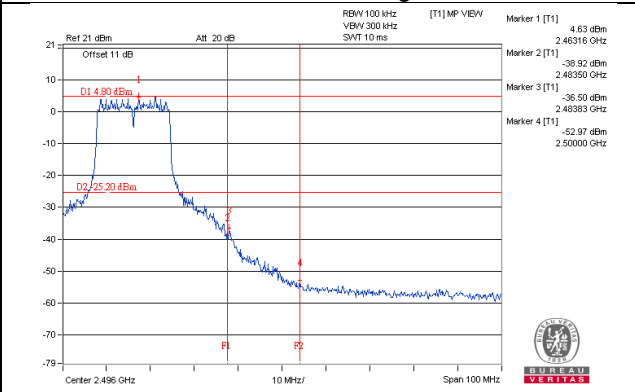

802.11n (HT20)_Chain 0

CH 1

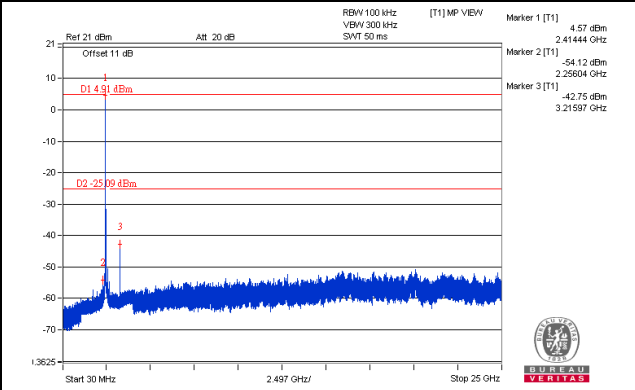
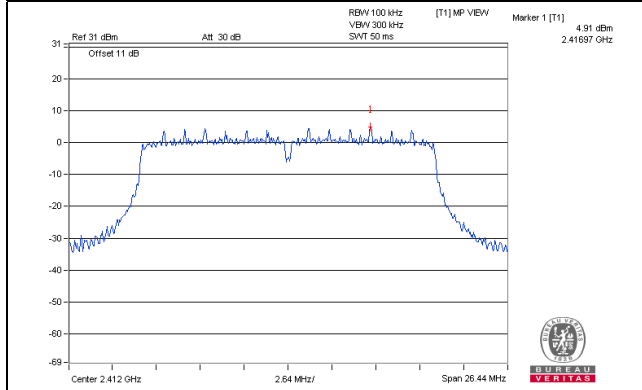

CH 6

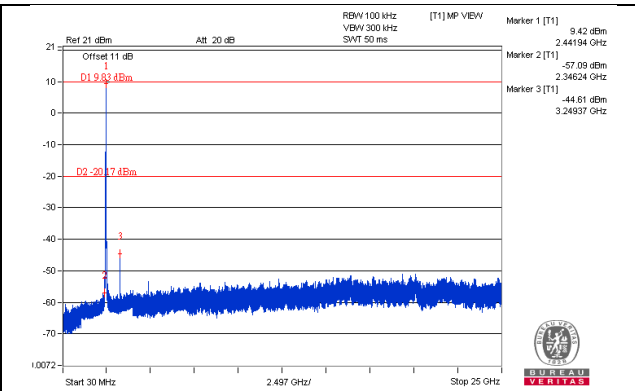
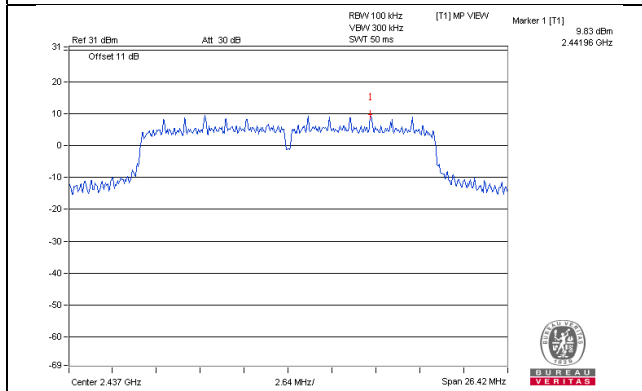

CH 11

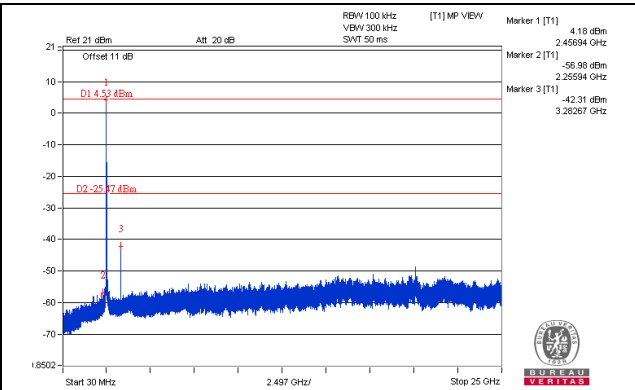
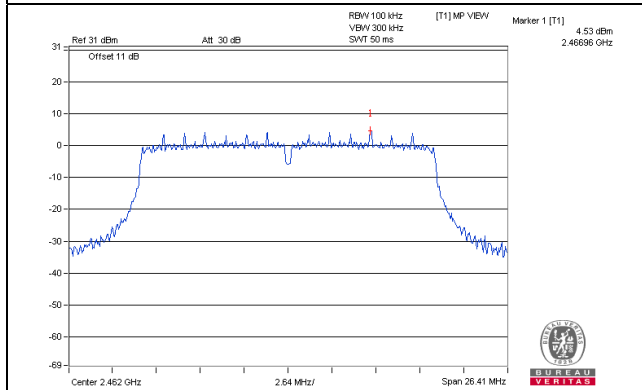

CH 1 Band edge

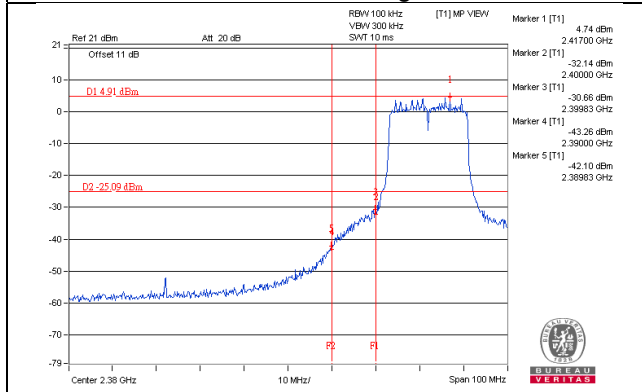

CH 11 Band edge

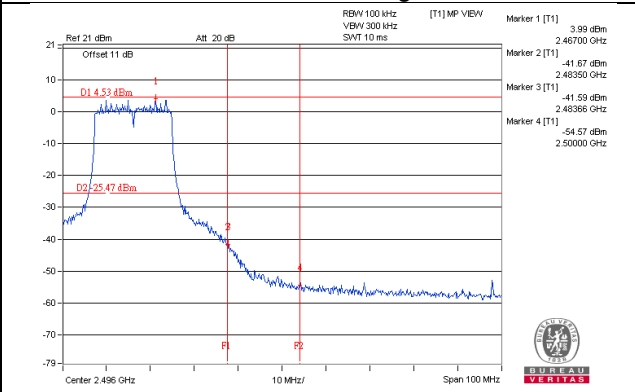

802.11n (HT20)_Chain 1

CH 1

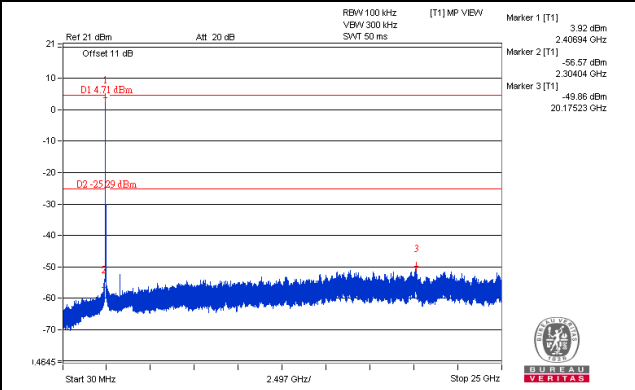
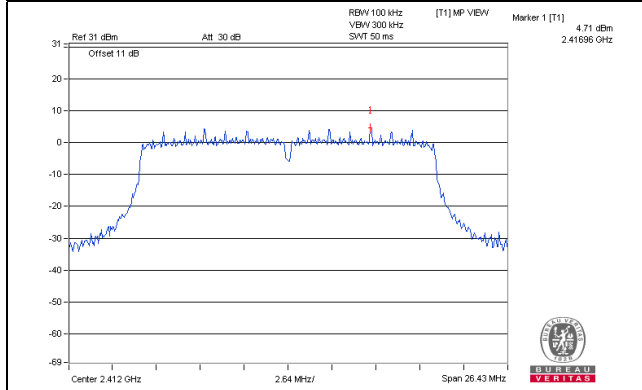

CH 6

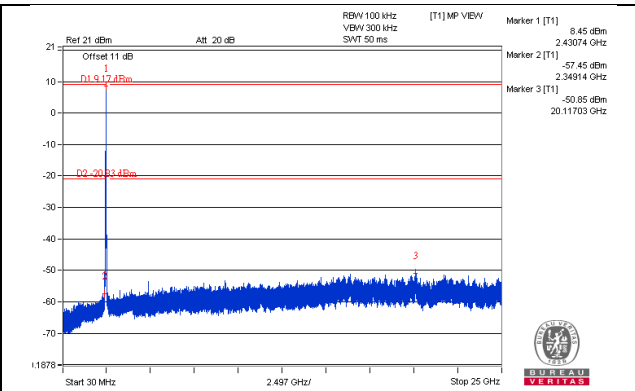
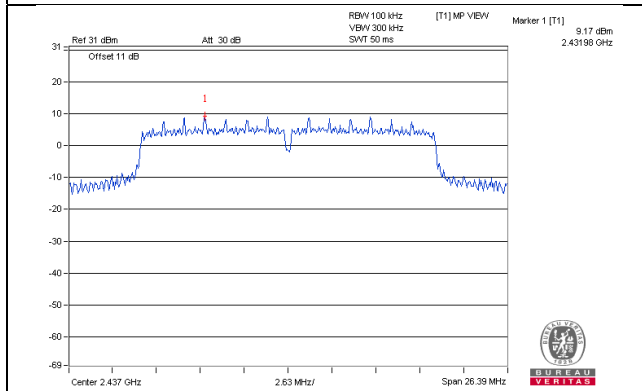

CH 11

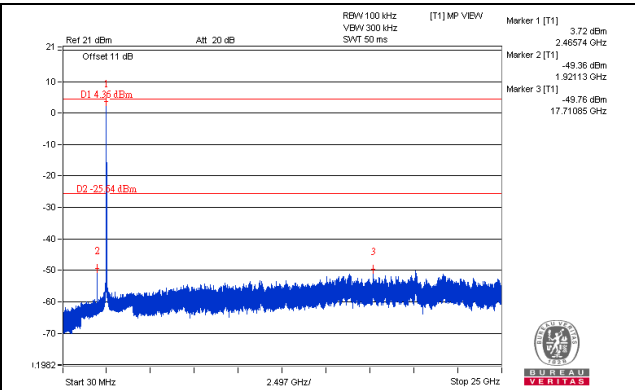
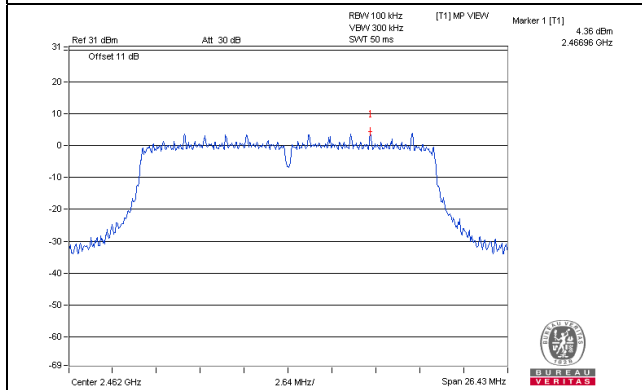

CH 1 Band edge

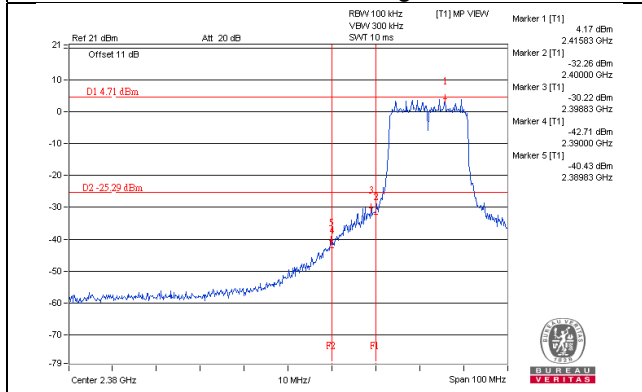

CH 11 Band edge

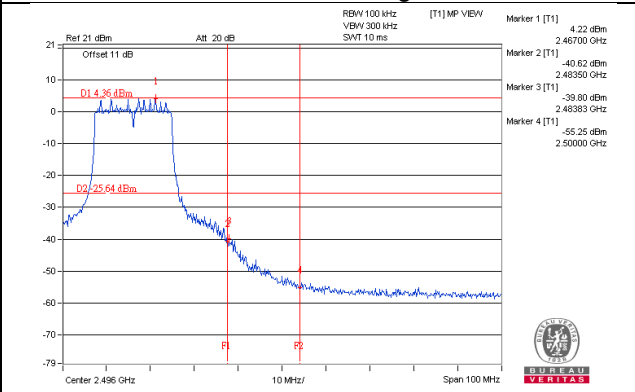

802.11n (HT40)_Chain 0

CH 3

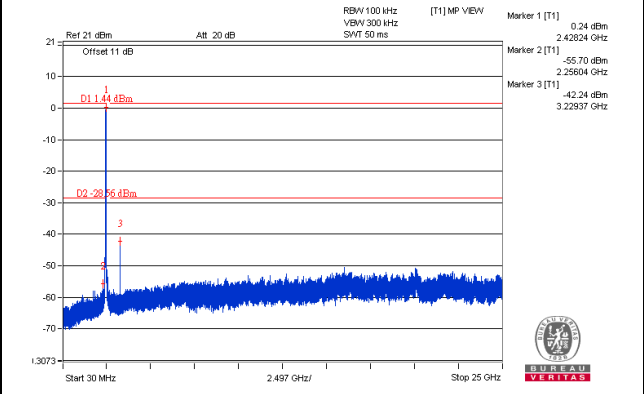
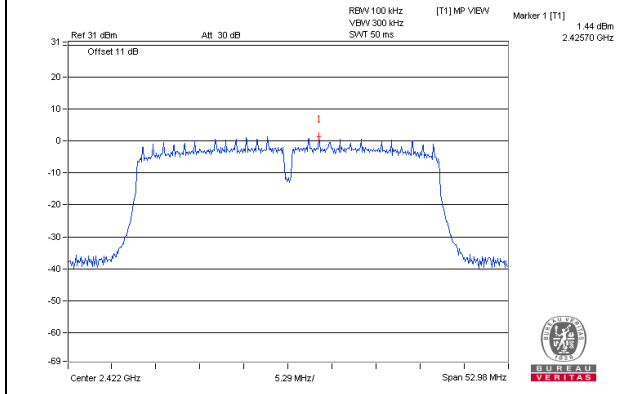

CH 6

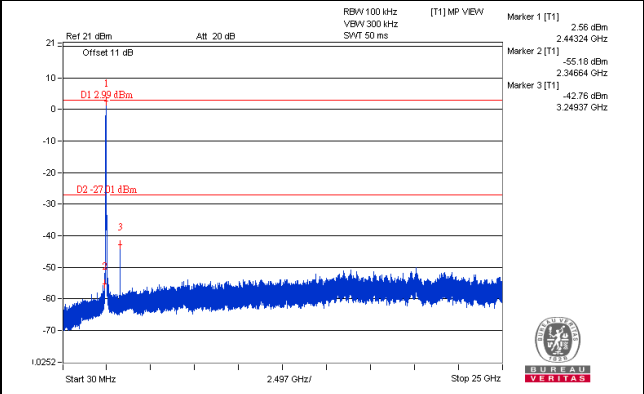
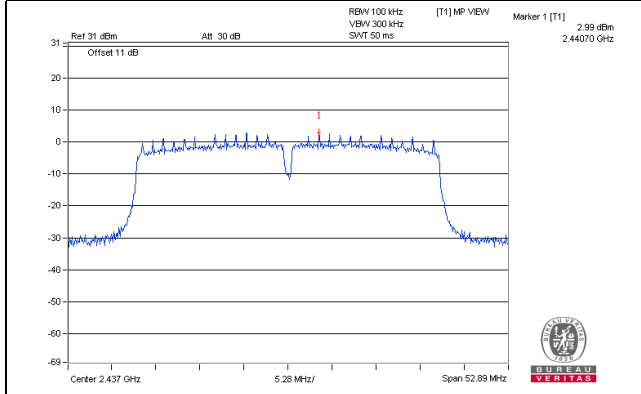

CH 9

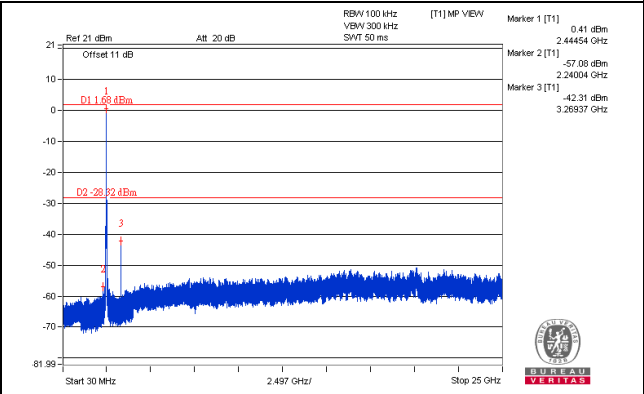
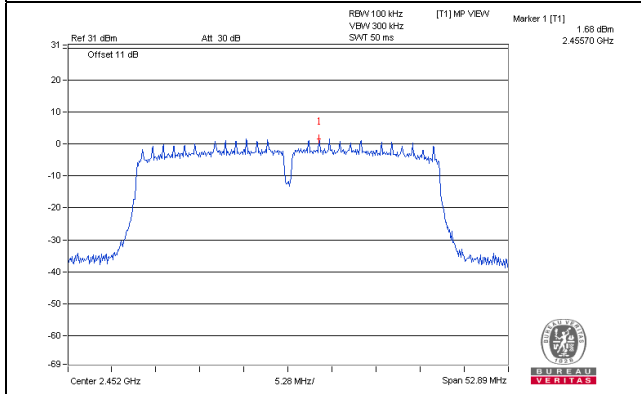

CH 3 Band edge

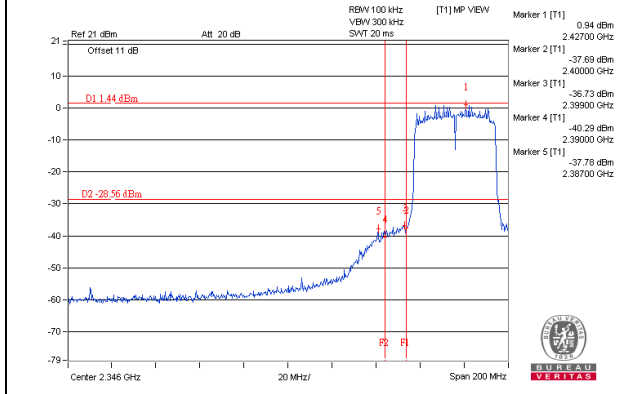

CH 9 Band edge

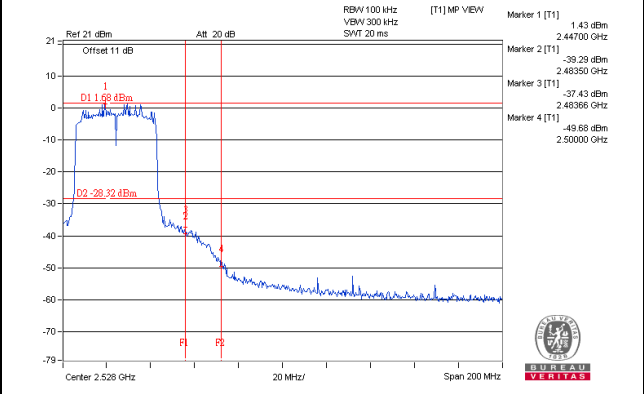

802.11n (HT40)_Chain 1

CH 3

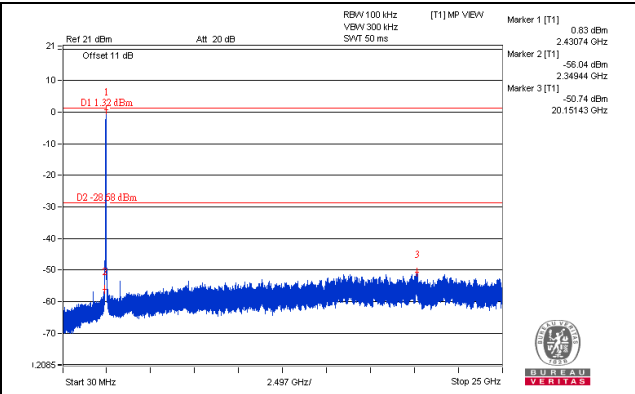
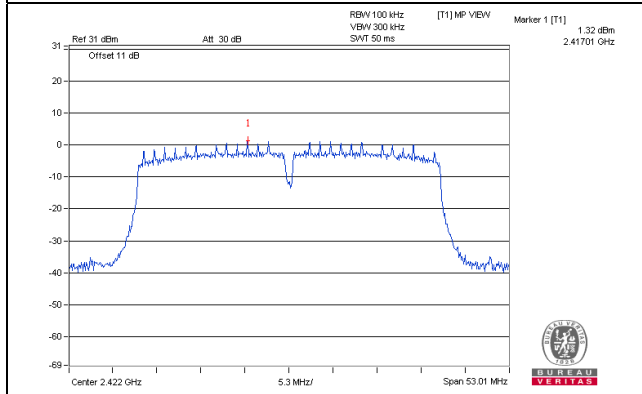

CH 6

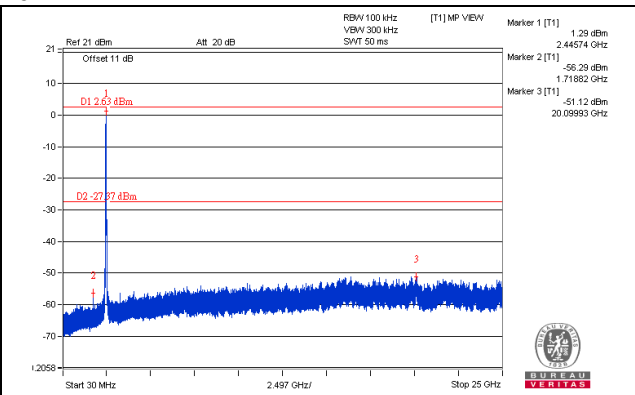
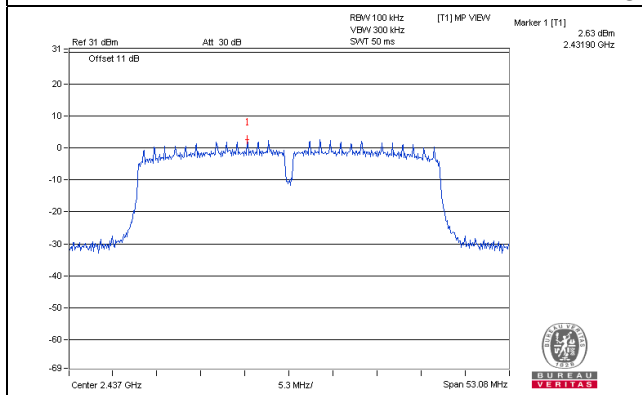

CH 9

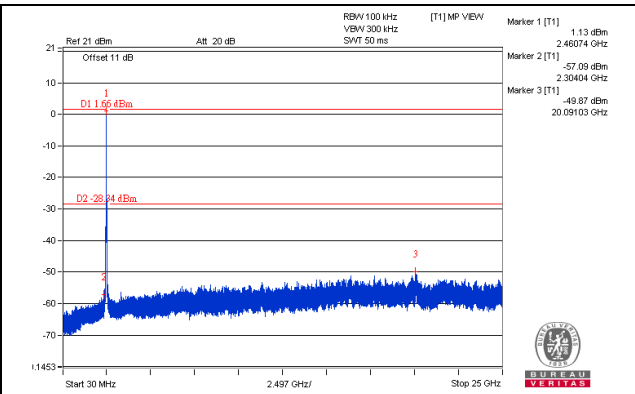
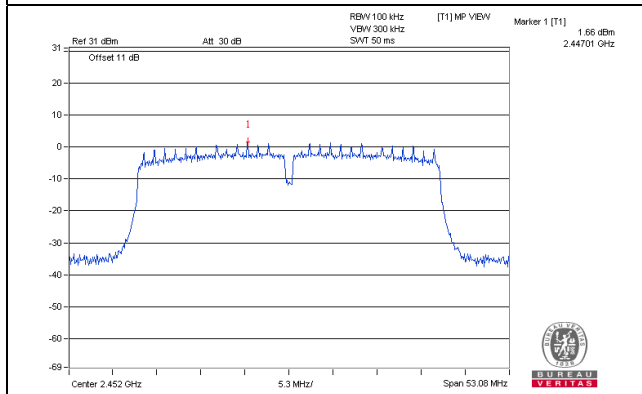

CH 3 Band edge

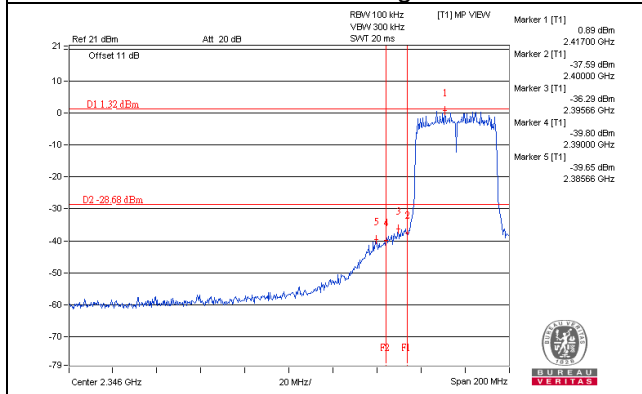

CH 9 Band edge

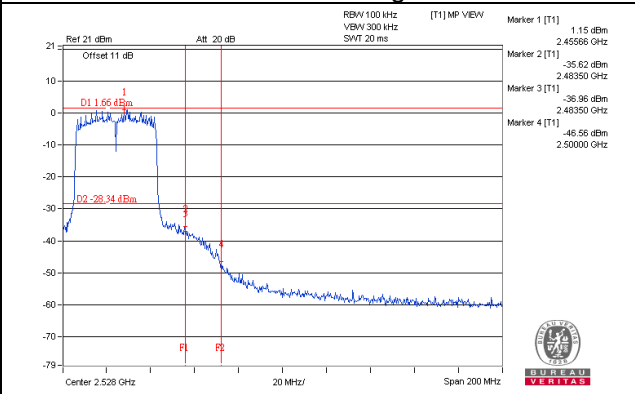

Radio 1: Beamforming Mode
802.11n (HT20)_Chain 0

CH 1

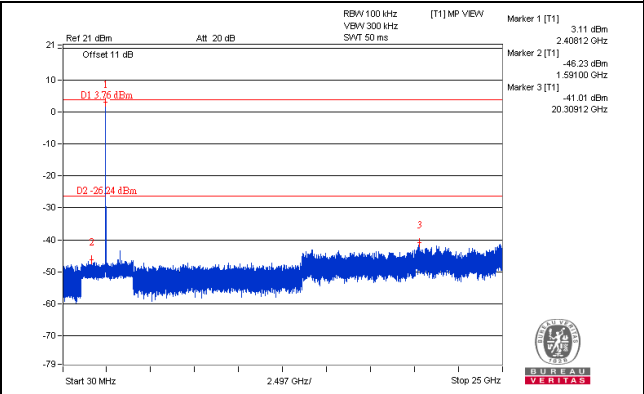
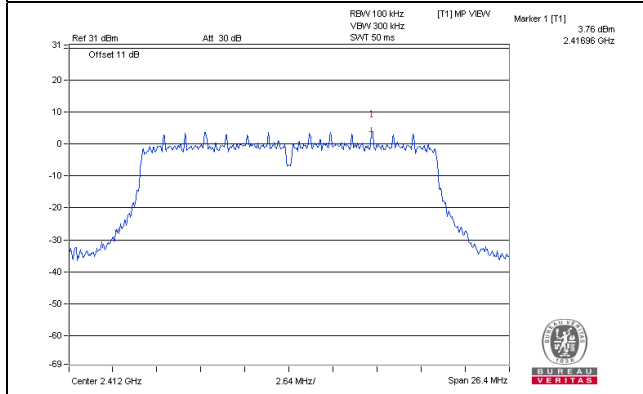

CH 6

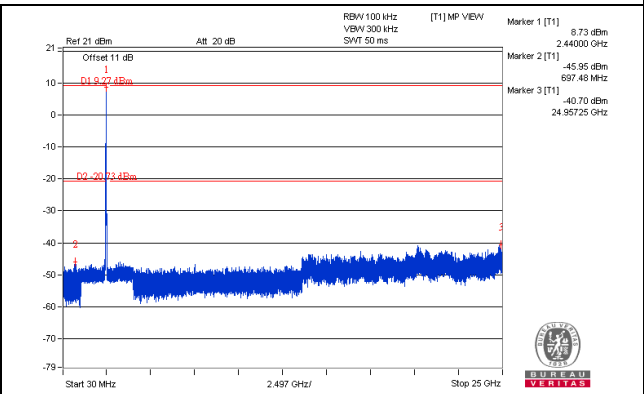
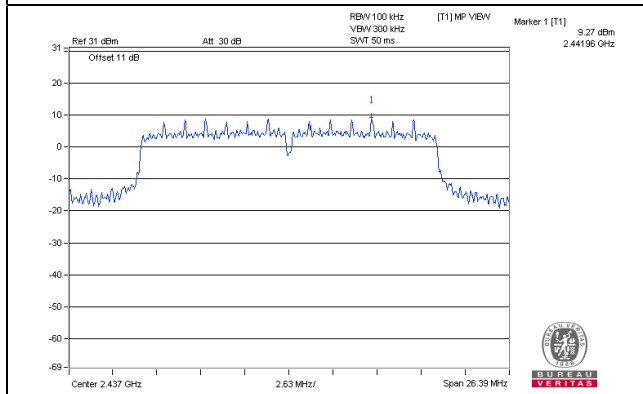

CH 11

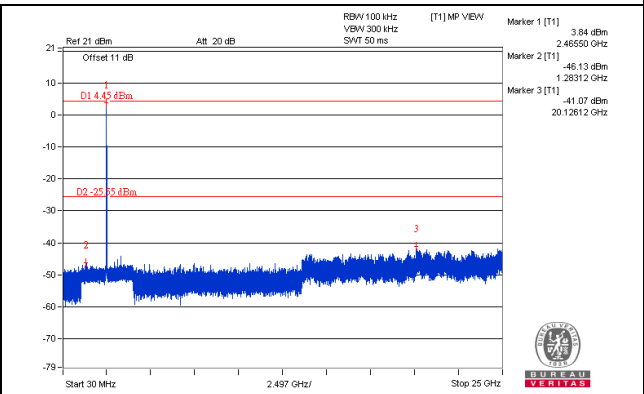
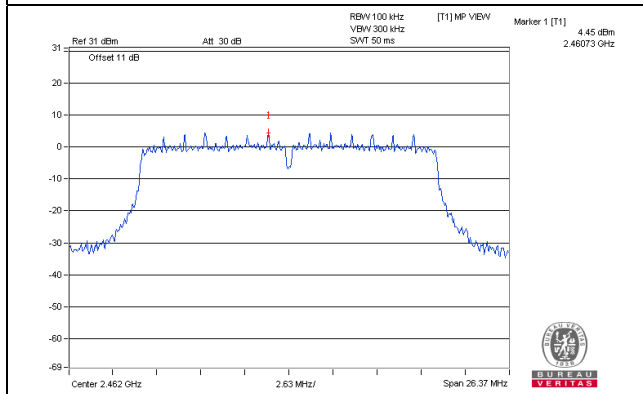

CH 1 Band edge

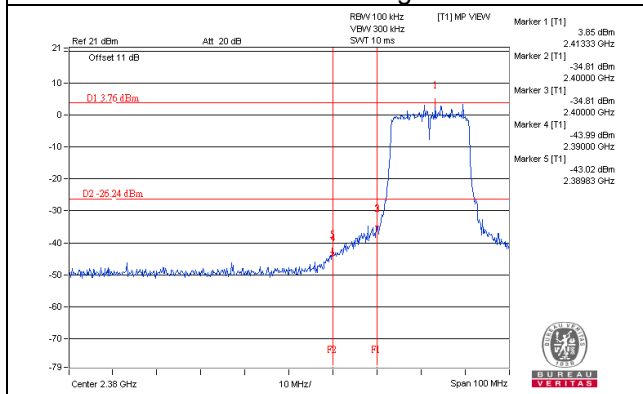

CH 11 Band edge

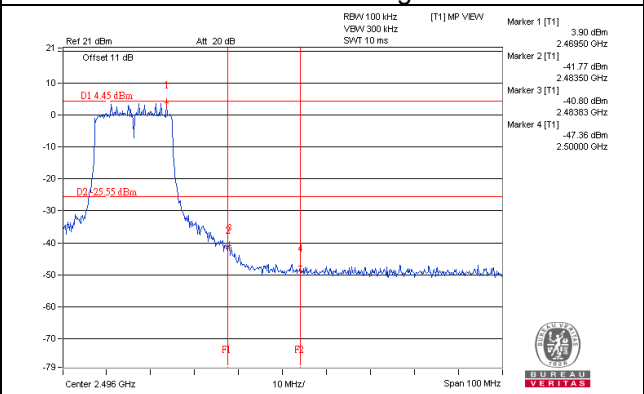

802.11n (HT20)_Chain 1

CH 1

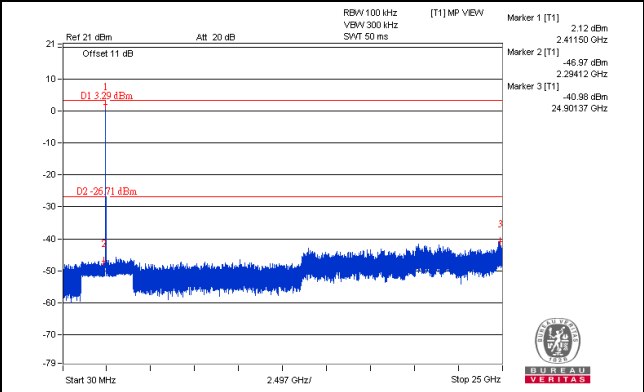
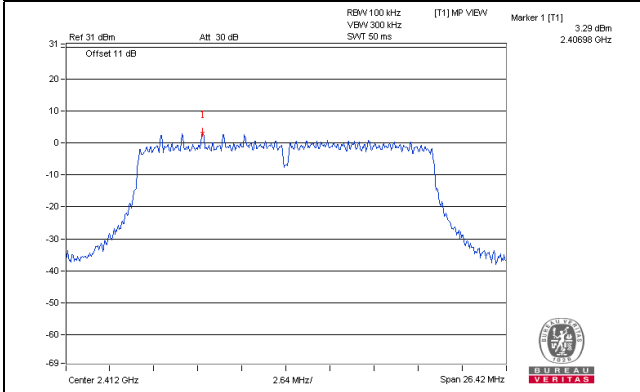

CH 6

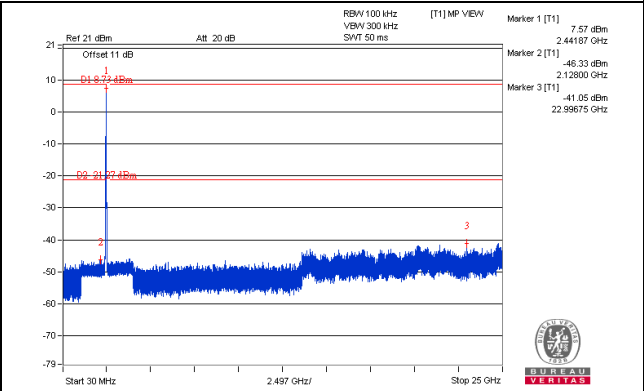
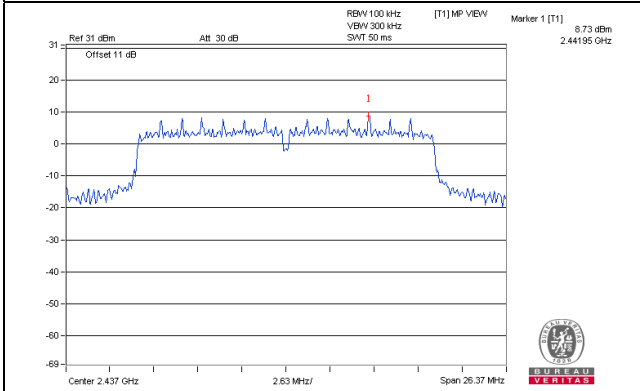

CH 11

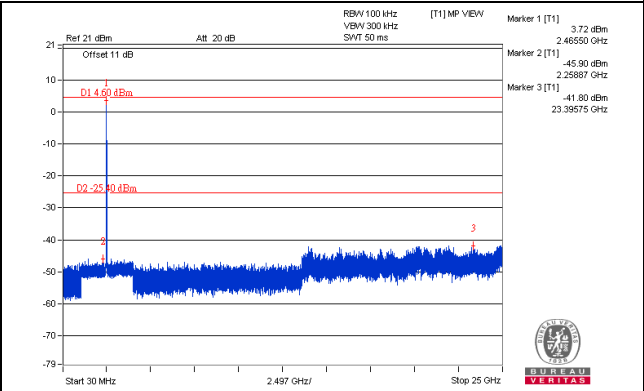
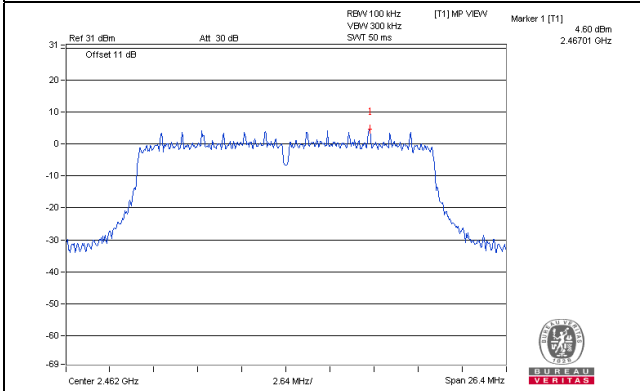

CH 1 Band edge

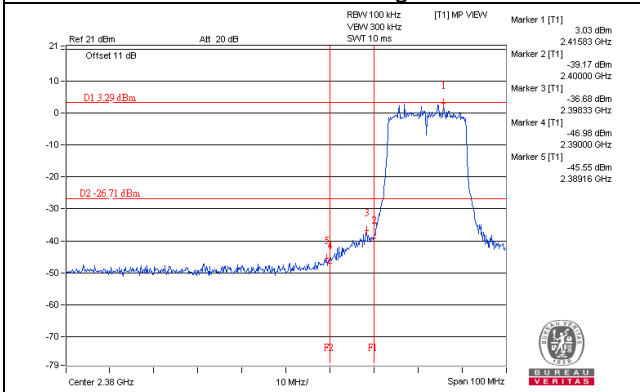

CH 11 Band edge

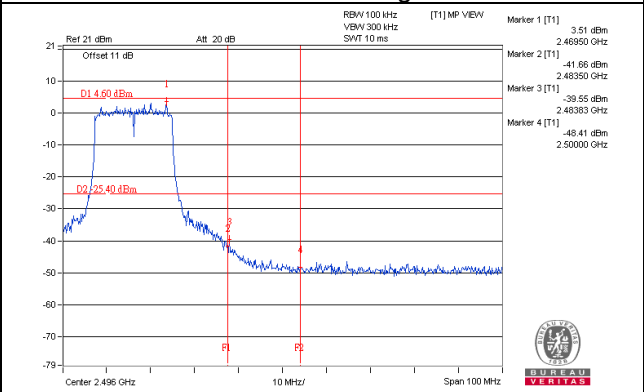

802.11n (HT40)_Chain 0

CH 3

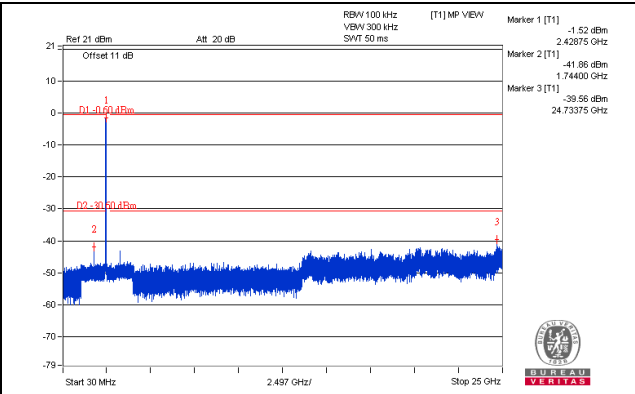
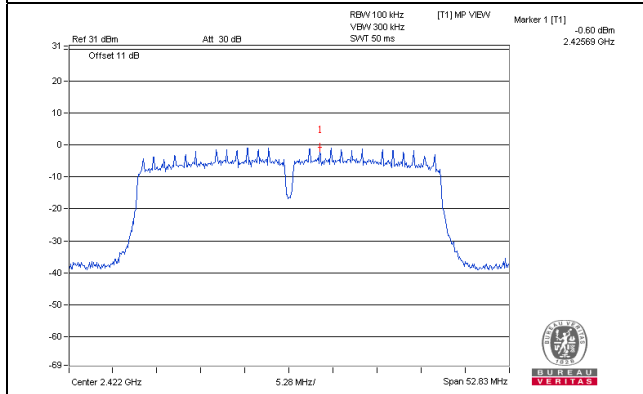

CH 6

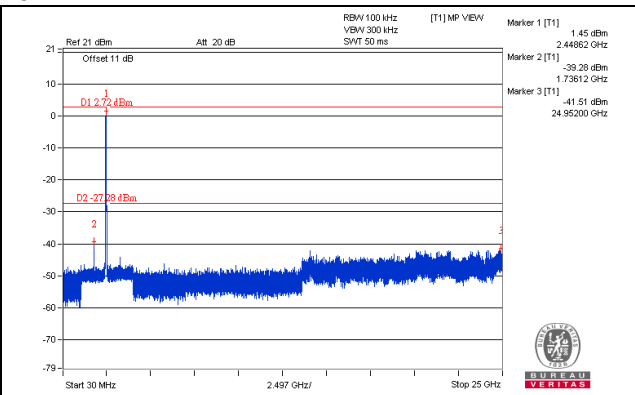
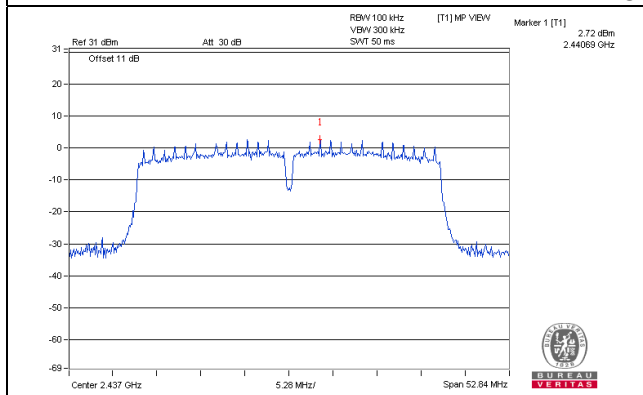

CH 9

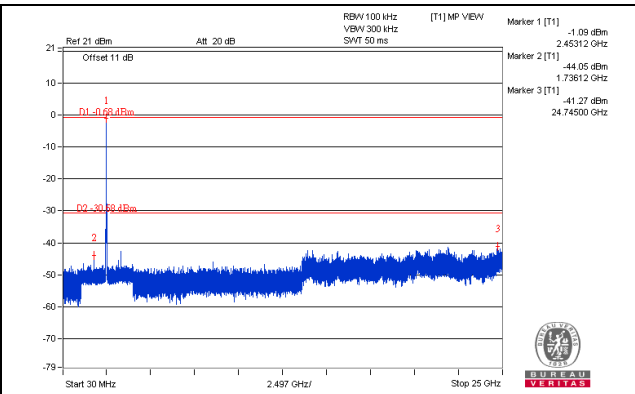
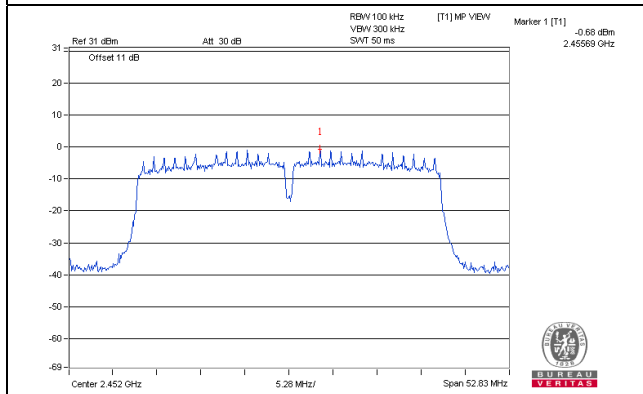

CH 3 Band edge

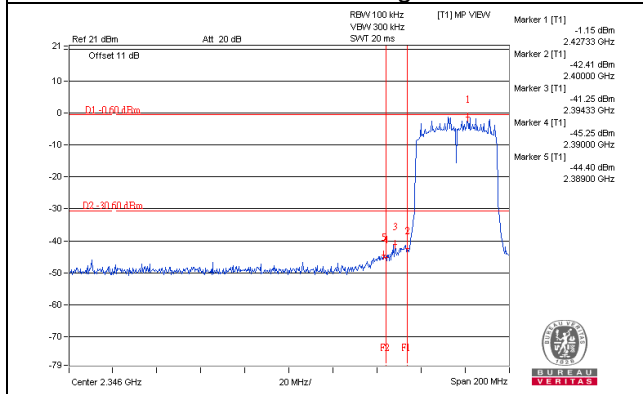

CH 9 Band edge

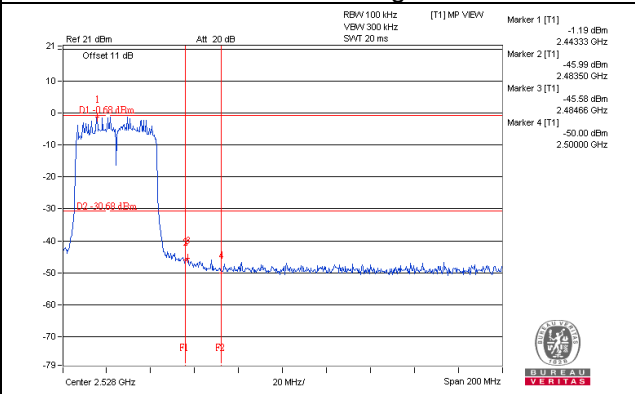

802.11n (HT40)_Chain 1

CH 3

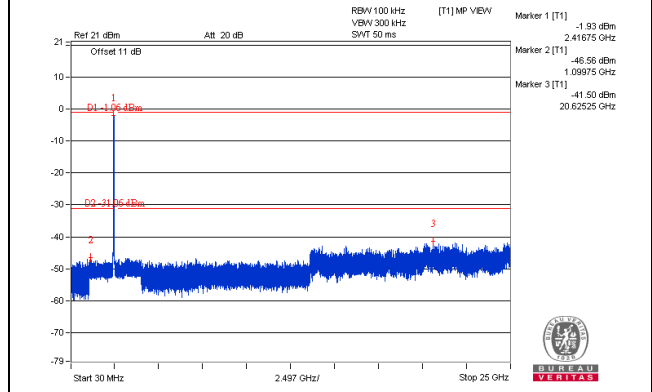
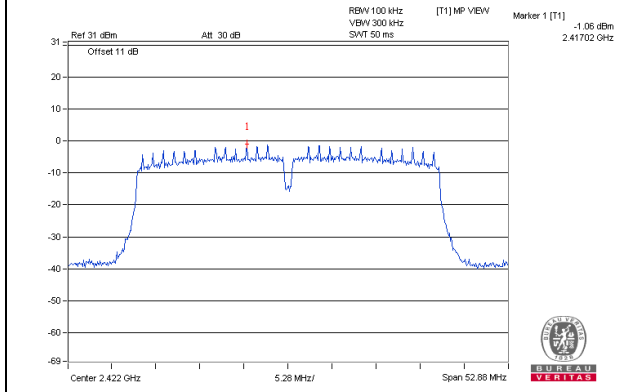

CH 6

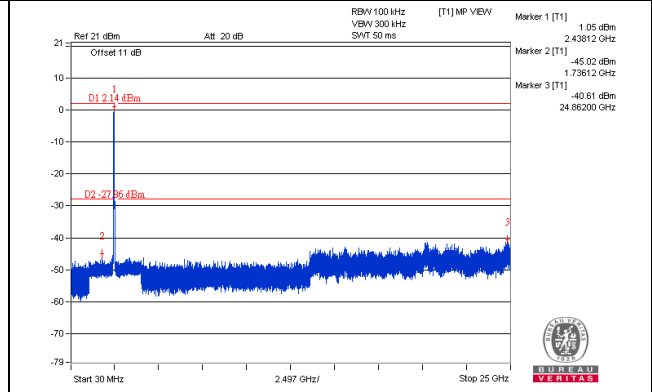
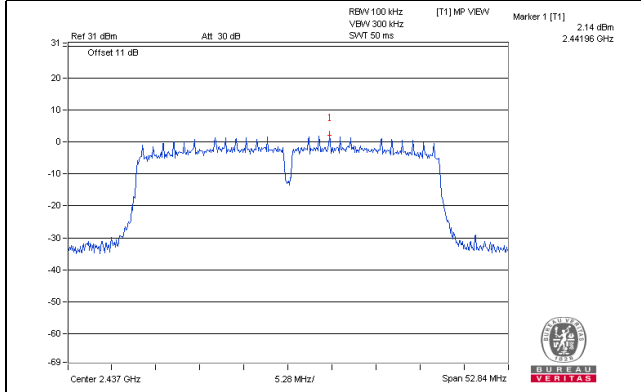

CH 9

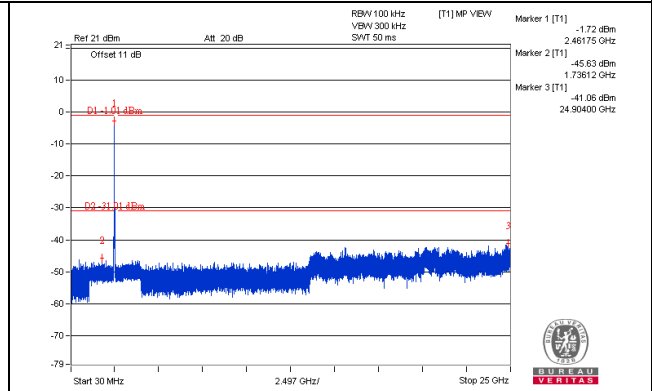
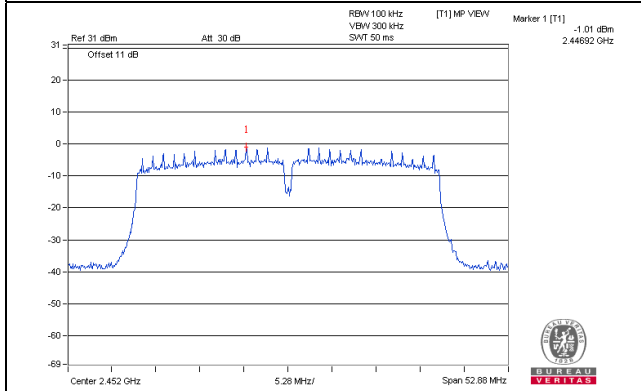

CH 3 Band edge

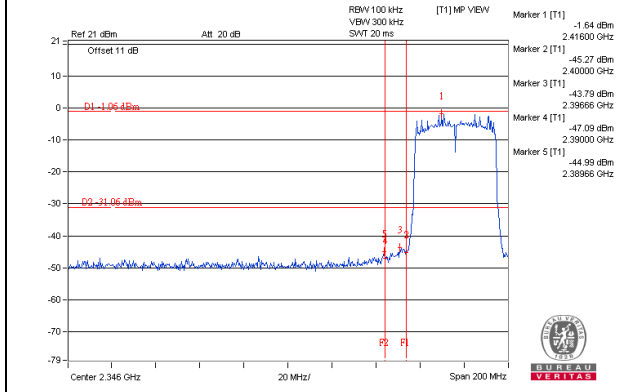

CH 9 Band edge

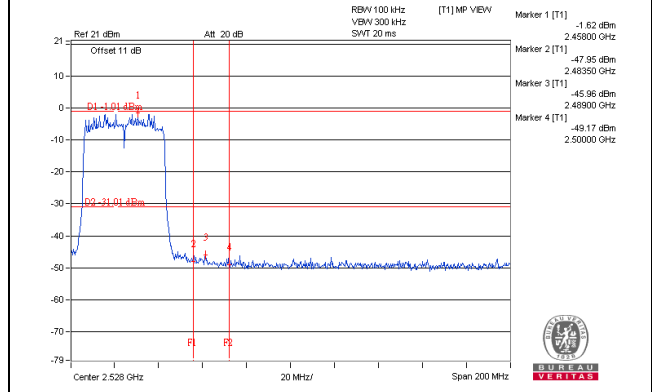

Radio 3: CDD Mode

802.11b

CH 1

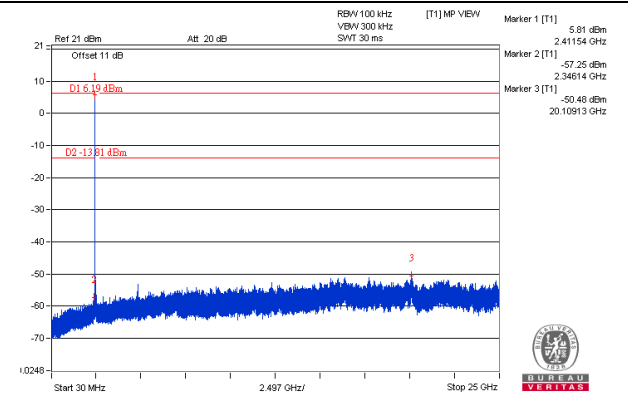
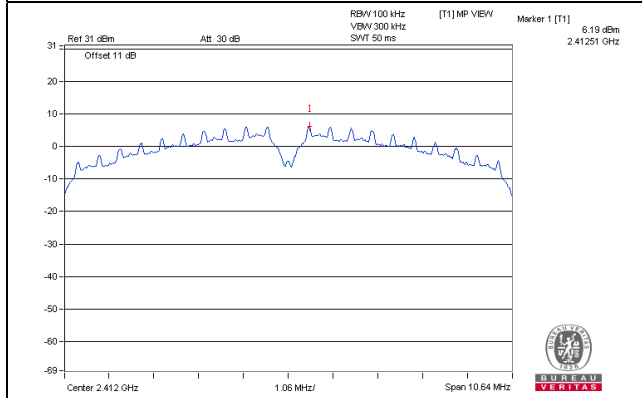

CH 6

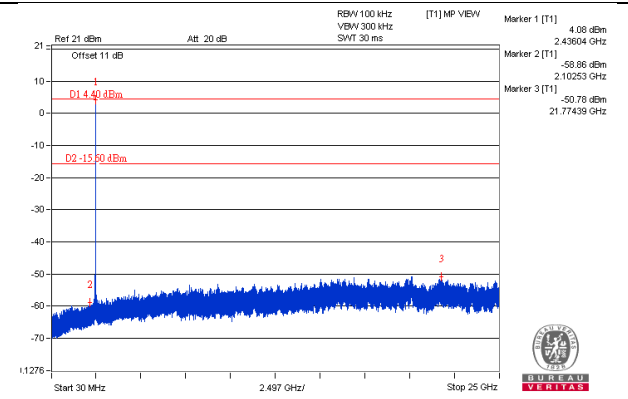
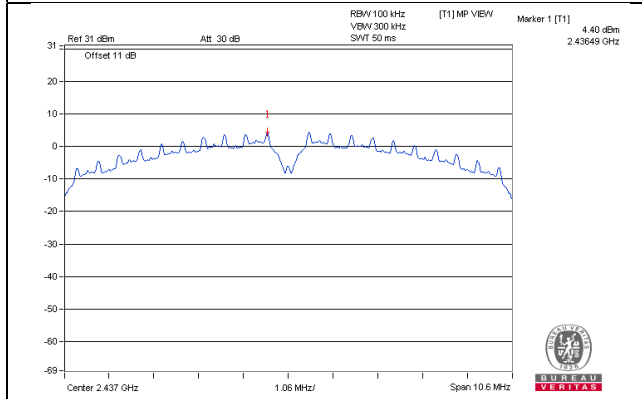

CH 11

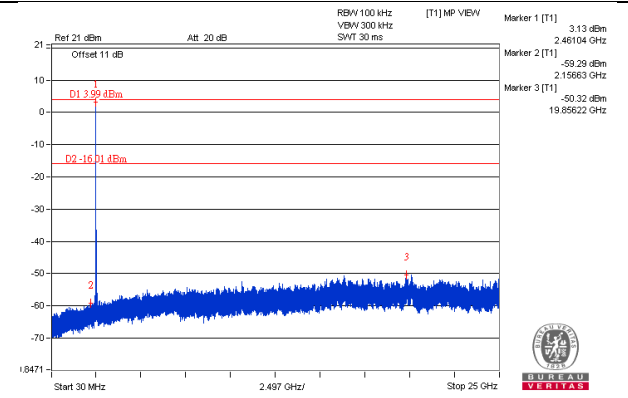
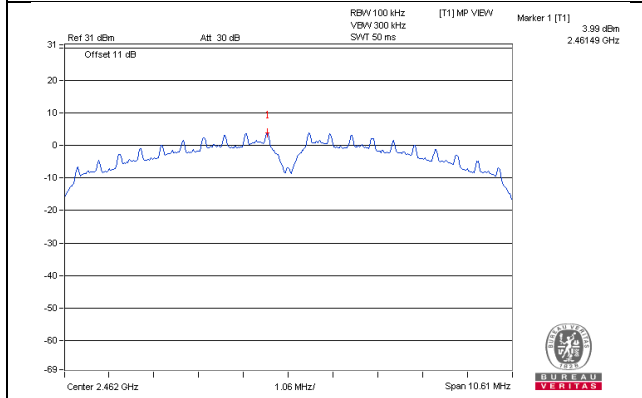

CH 1 Band edge

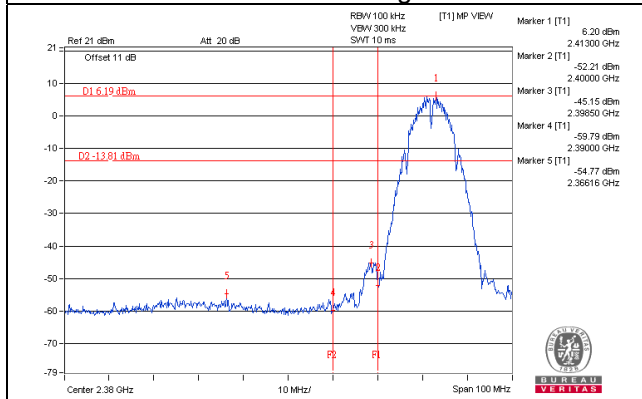

CH 11 Band edge

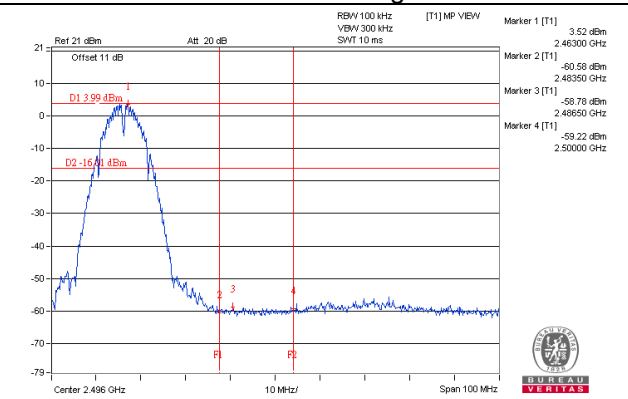

802.11g

CH 1

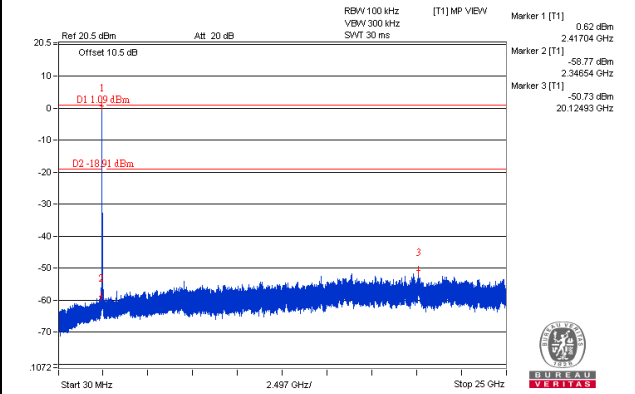
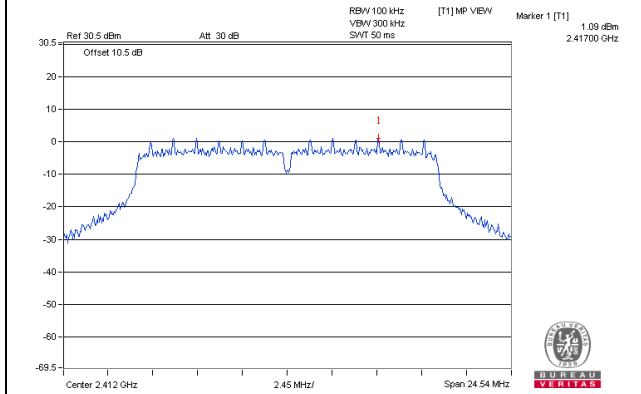

CH 6

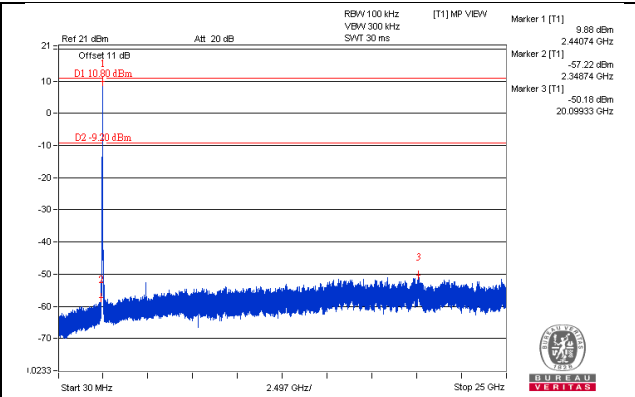
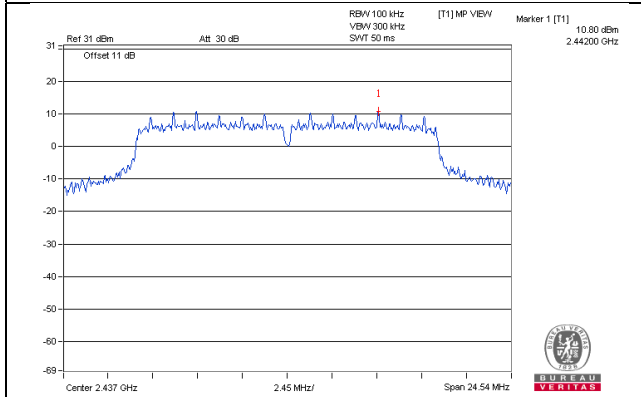

CH 11

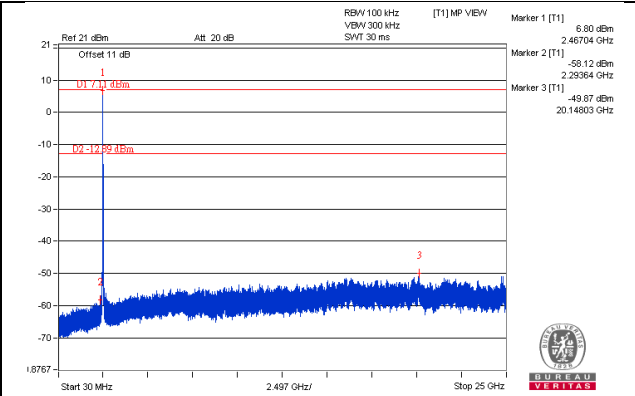
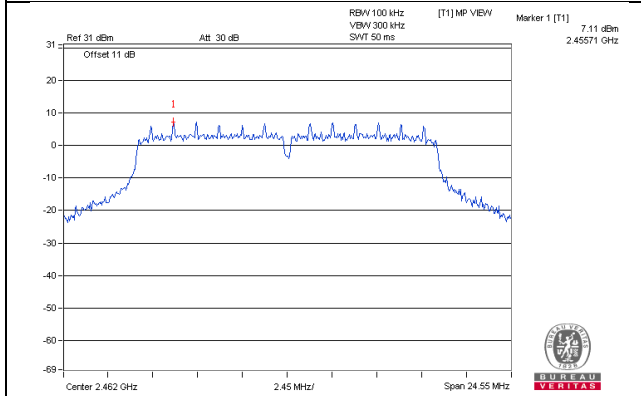

CH 1 Band edge

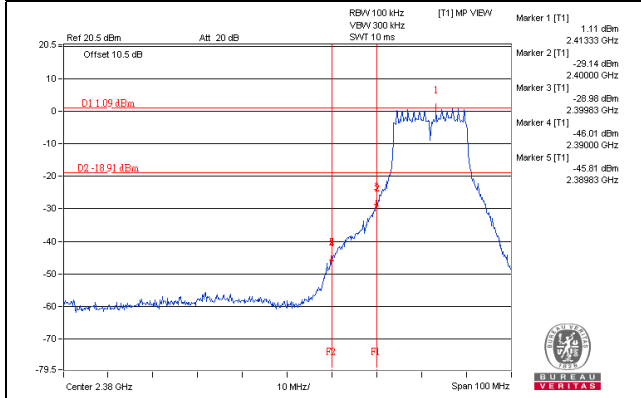

CH 11 Band edge

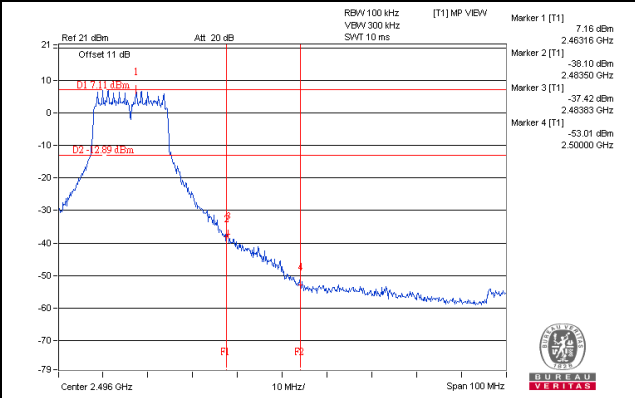

802.11n (HT20)

CH 1

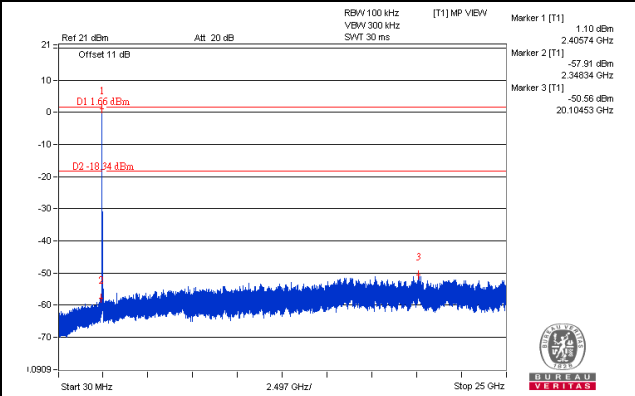
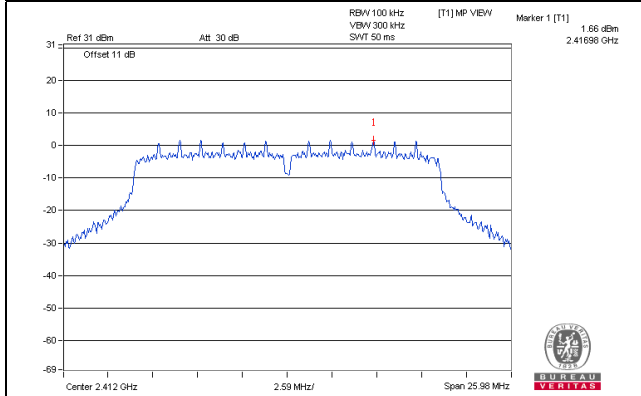

CH 6

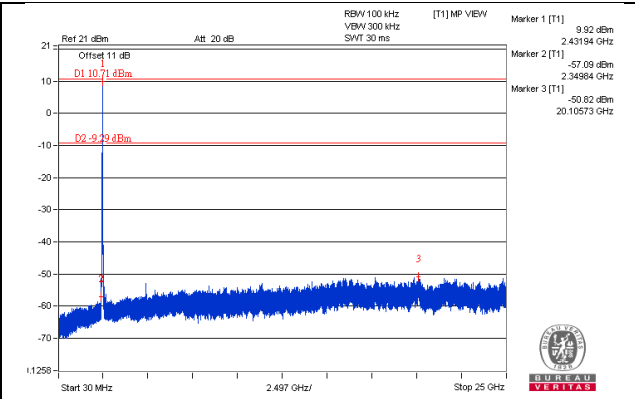
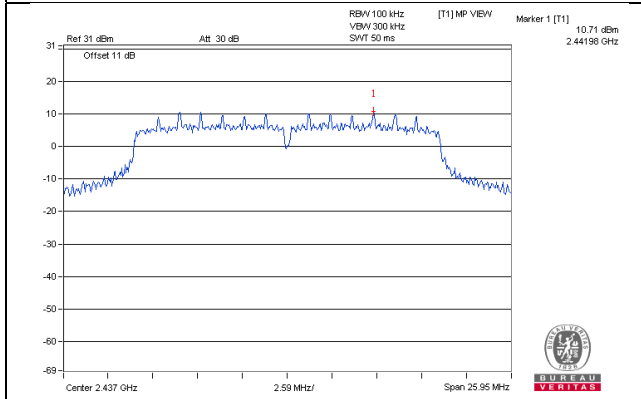

CH 11

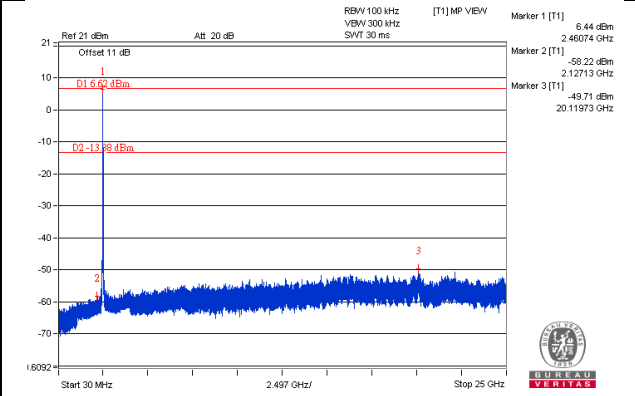
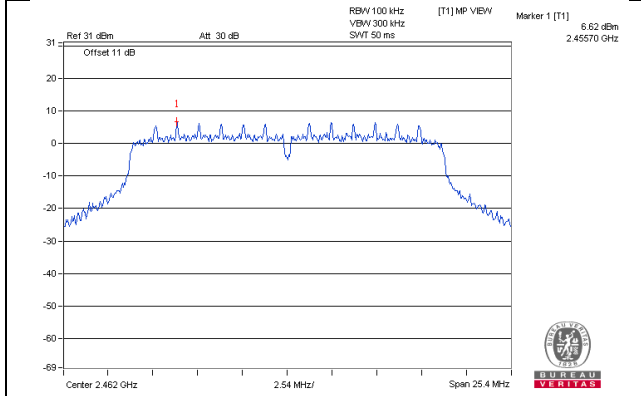

CH 1 Band edge

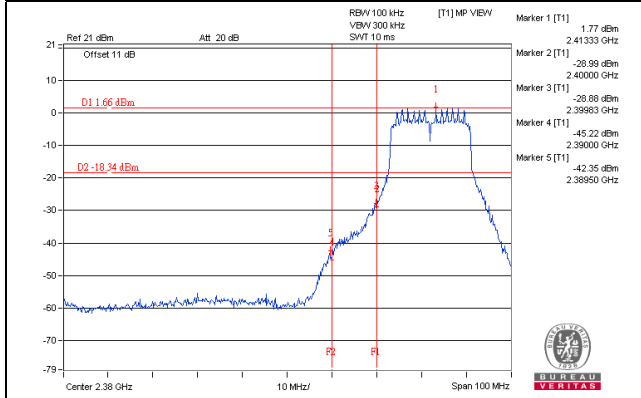

CH 11 Band edge

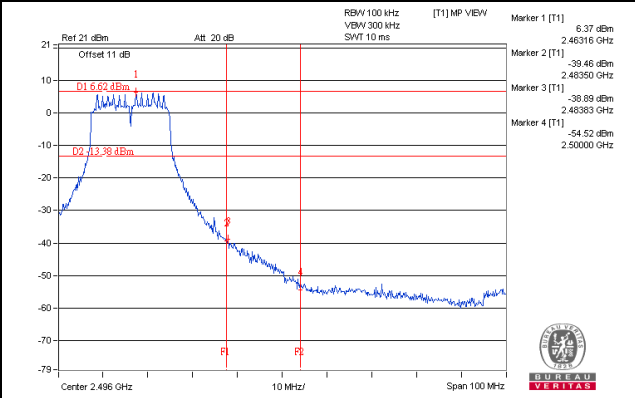

802.11n (HT40)

CH 3

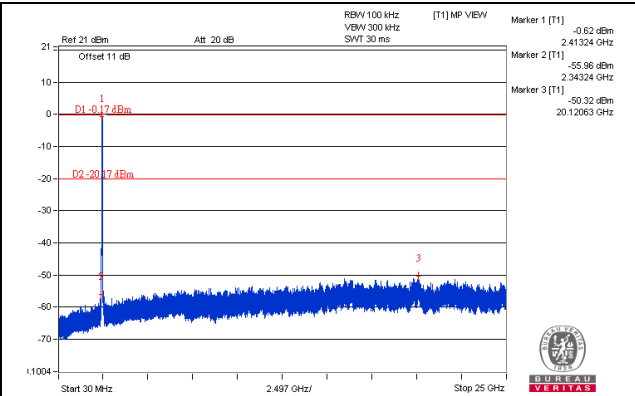
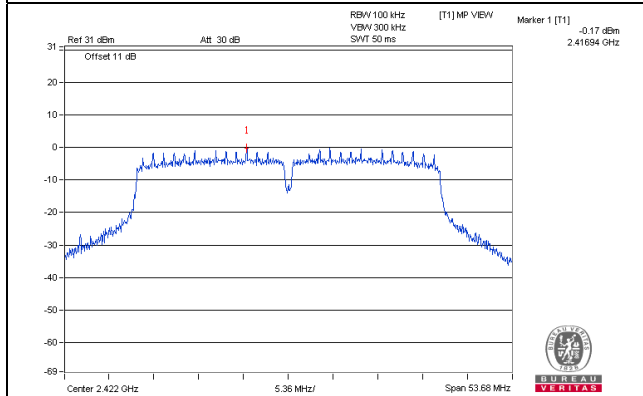

CH 6

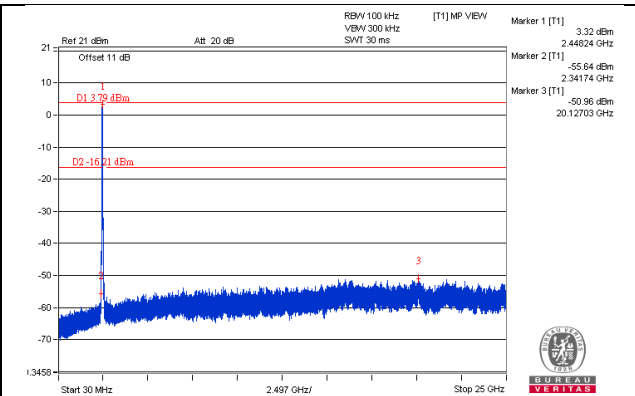
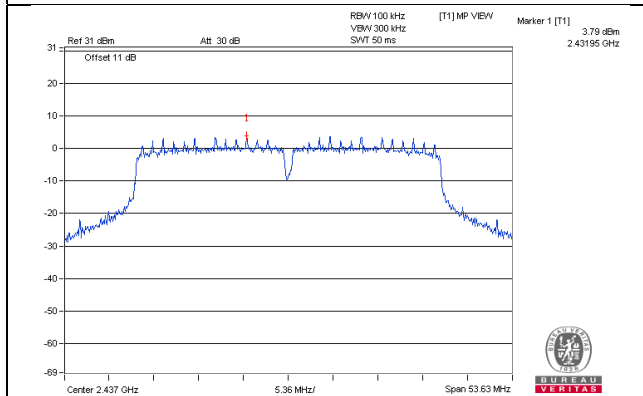

CH 9

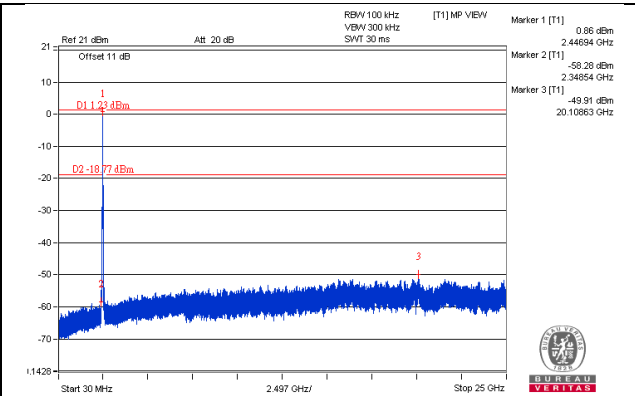
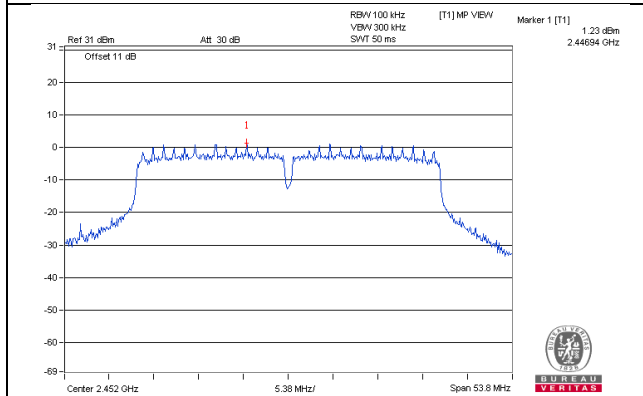

CH 3 Band edge

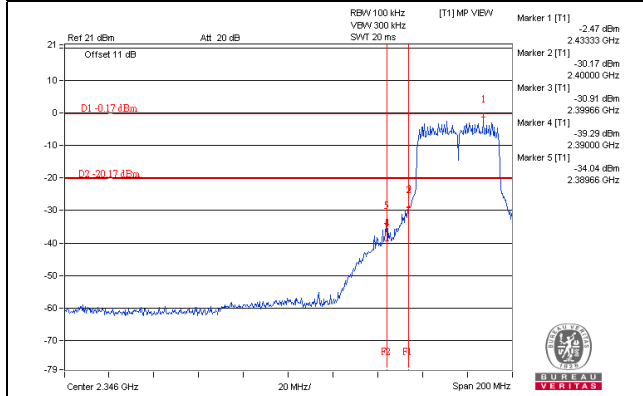

CH 9 Band edge

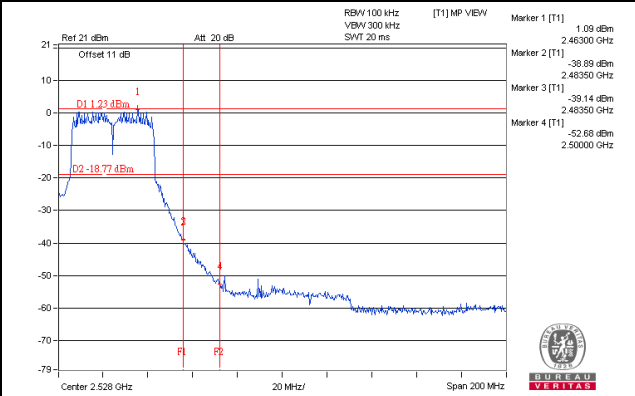

5 Pictures of Test Arrangements

Please refer to the attached file (Test Setup Photo).

Appendix – Information on the Testing Laboratories

We, Bureau Veritas Consumer Products Services (H.K.) Ltd., Taoyuan Branch, were founded in 1988 to provide our best service in EMC, Radio, Telecom and Safety consultation. Our laboratories are accredited and approved according to ISO/IEC 17025.

If you have any comments, please feel free to contact us at the following:

Linko EMC/RF Lab

Tel: 886-2-26052180

Fax: 886-2-26051924

Hsin Chu EMC/RF/Telecom Lab

Tel: 886-3-6668565

Fax: 886-3-6668323

Hwa Ya EMC/RF/Safety Lab

Tel: 886-3-3183232

Fax: 886-3-3270892

Email: service.adt@tw.bureauveritas.com

Web Site: www.bureauveritas-adt.com

The address and road map of all our labs can be found in our web site also.

--- END ---